



THE DATASHEET OF MAX472EPA



Not Recommended for New Designs

This product was manufactured for Maxim by an outside wafer foundry using a process that is no longer available. It is not recommended for new designs. The data sheet remains available for existing users.

A Maxim replacement or an industry second-source may be available. Please see the QuickView data sheet for this part or contact technical support for assistance.

For further information, [contact Maxim's Applications Tech Support](#).

MAXIM

Precision, High-Side Current-Sense Amplifiers

MAX471/MAX472

General Description

The MAX471/MAX472 are complete, bidirectional, high-side current-sense amplifiers for portable PCs, telephones, and other systems where battery/DC power-line monitoring is critical. High-side power-line monitoring is especially useful in battery-powered systems, since it does not interfere with the ground paths of the battery chargers or monitors often found in "smart" batteries.

The MAX471 has an internal 35mΩ current-sense resistor and measures battery currents up to ±3A. For applications requiring higher current or increased flexibility, the MAX472 functions with external sense and gain-setting resistors. Both devices have a current output that can be converted to a ground-referred voltage with a single resistor, allowing a wide range of battery voltages and currents.

An open-collector SIGN output indicates current-flow direction, so the user can monitor whether a battery is being charged or discharged. Both devices operate from 3V to 36V, draw less than 100μA over temperature, and include a 18μA max shutdown mode.

Applications

- Portable PCs:
 - Notebooks/Subnotebooks/Palmtops
- Smart Battery Packs
- Cellular Phones
- Portable Phones
- Portable Test/Measurement Systems
- Battery-Operated Systems
- Energy Management Systems

Typical Operating Circuit

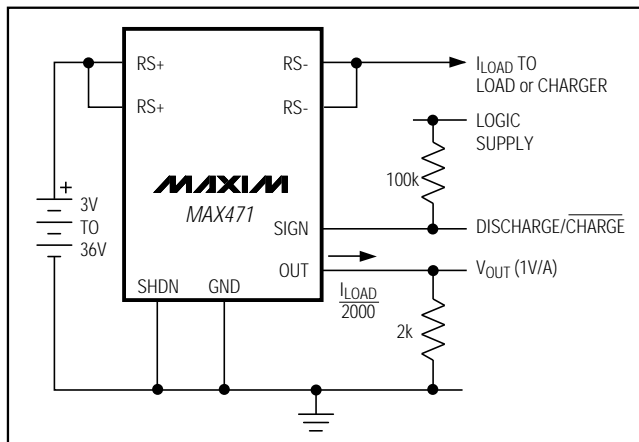

Features

- ◆ Complete High-Side Current Sensing
- ◆ Precision Internal Sense Resistor (MAX471)
- ◆ 2% Accuracy Over Temperature
- ◆ Monitors Both Charge and Discharge
- ◆ 3A Sense Capability with Internal Sense Resistor (MAX471)
- ◆ Higher Current-Sense Capability with External Sense Resistor (MAX472)
- ◆ 100μA Max Supply Current
- ◆ 18μA Max Shutdown Mode
- ◆ 3V to 36V Supply Operation
- ◆ 8-Pin DIP/SO Packages

Ordering Information

PART	TEMP. RANGE	PIN-PACKAGE
MAX471CPA	0°C to +70°C	8 Plastic DIP
MAX471CSA	0°C to +70°C	8 SO
MAX471EPA	-40°C to +85°C	8 Plastic DIP
MAX471ESA	-40°C to +85°C	8 SO
MAX472CPA	0°C to +70°C	8 Plastic DIP
MAX472CSA	0°C to +70°C	8 SO
MAX472EPA	-40°C to +85°C	8 Plastic DIP
MAX472ESA	-40°C to +85°C	8 SO

Pin Configurations

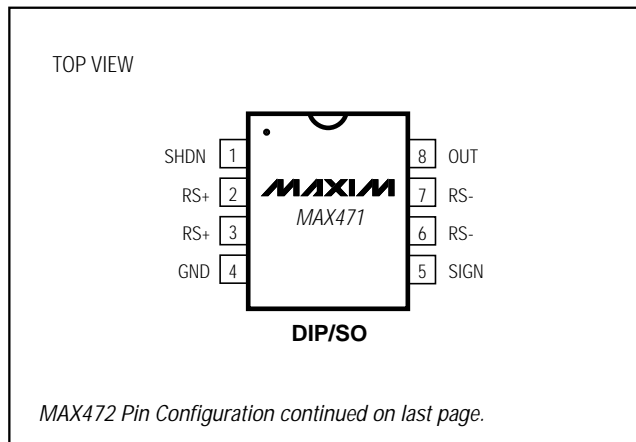

MAX472 Pin Configuration continued on last page.

Precision, High-Side Current-Sense Amplifiers

ABSOLUTE MAXIMUM RATINGS

Supply Voltage, RS+, RS-, VCC to GND.....-0.3V, +40V
 RMS Current, RS+ to RS- (MAX471 only).....±3.3A
 Peak Current, (RS+ to RS-)see Figure 5
 Differential Input Voltage, RG1 to RG2 (MAX472 only)±0.3V
 Voltage at Any Pin Except SIGN
 MAX471 only-0.3V to (RS+ - 0.3V)
 MAX472 only-0.3V to (VCC + 0.3V)
 Voltage at SIGN.....-0.3V to +40V
 Current into SHDN, GND, OUT, RG1, RG2, VCC.....±50mA
 Current into SIGN.....+10mA, -50mA

Continuous Power Dissipation (TA = +70°C)

MAX471 (Note 1):
 Plastic DIP (derate 17.5mW/°C above +70°C)1.4W
 SO (derate 9.9mW/°C above +70°C).....791mW
 MAX472 :
 Plastic DIP (derate 9.09mW/°C above +70°C)727mW
 SO (derate 5.88mW/°C above +70°C).....471mW
 Operating Temperature Ranges
 MAX47_C_A.....0°C to +70°C
 MAX47_E_A.....-40°C to +85°C
 Junction Temperature Range.....-60°C to +150°C
 Storage Temperature Range.....-60°C to +160°C
 Lead Temperature (soldering, 10sec).....+300°C

Note 1: Due to special packaging considerations, MAX471 (DIP, SO) has a higher power dissipation rating than the MAX472. RS+ and RS- must be soldered to large copper traces to achieve this dissipation rating.

Stresses beyond those listed under "Absolute Maximum Ratings" may cause permanent damage to the device. These are stress ratings only, and functional operation of the device at these or any other conditions beyond those indicated in the operational sections of the specifications is not implied. Exposure to absolute maximum rating conditions for extended periods may affect device reliability.

ELECTRICAL CHARACTERISTICS—MAX471

(RS+ = +3V to +36V, TA = TMIN to TMAX, unless otherwise noted. Typical values are at TA = +25°C.)

PARAMETER	SYMBOL	CONDITIONS	MIN	TYP	MAX	UNITS	
Supply Voltage	VRS+		3		36	V	
Supply Current	IRS+	ILOAD = 0A, excludes ISIGN		50	113	µA	
Sense Current	ILOAD				±3	ARMS	
Sense Resistor	RSENSE			35	70	mΩ	
Current-Sense Ratio	IOUT/ ILOAD	ILOAD = 1A, RS+ = 10V	MAX471C	0.490	0.500	0.510	mA/A
			MAX471E	0.4875	0.500	0.5125	
No-Load OUT Error		ILOAD = 0A, RS+ = 10V	MAX471C			2.5	µA
			MAX471E			3.0	
Low-Level OUT Error		ILOAD = 30mA, RS+ = 10V	MAX471C			±2.5	µA
			MAX471E			±3.0	
Power-Supply Rejection Ratio	PSRR	3V ≤ RS+ ≤ 36V, ILOAD = 1A			0.1	%/V	
SIGN Threshold (ILOAD required to switch SIGN)		MAX471C		±4.0	±6.0	mA	
		MAX471E			±7.0		
SIGN Output Leakage Current		VSIGN = 36V			1.0	µA	
SIGN Sink Current	IOL	VSIGN = 0.3V	0.1			mA	
Shutdown Supply Current	IRS+(SHDN)	VSHDN = 2.4V; VCC = 3V to 20V		1.5	18.0	µA	
SHDN Input Low Voltage	VIL				0.3	V	
SHDN Input Low Current	IIL	VSHDN = 0V			1.0	µA	
SHDN Input High Voltage	VIH		2.4			V	
SHDN Input High Current	IIH	VSHDN = 2.4V			1.0	µA	
OUT Output Voltage Range	VOUT		0	VRS+ - 1.5		V	
OUT Output Resistance	ROUT	ILOAD = 3.0A, VOUT = 0V to (VRS+ - 1.5V)	1	3		MΩ	
OUT Rise, Fall Time	tR, tF	ILOAD = 50mA to 3.0A, ROUT = 2kΩ, COUT = 50pF, 10% to 90%		4		µs	
OUT Settling Time to 1% of Final Value	ts	ILOAD = 100mA to 3.0A, ROUT = 2kΩ, COUT = 50pF		15		µs	

Precision, High-Side Current-Sense Amplifiers

MAX471/MAX472

ELECTRICAL CHARACTERISTICS—MAX472

($V_{CC} = +3V$ to $+36V$, $R_{G1} = R_{G2} = 200\Omega$, $T_A = T_{MIN}$ to T_{MAX} , unless otherwise noted. Typical values are at $T_A = +25^\circ C$.)

PARAMETER	SYMBOL	CONDITIONS		MIN	TYP	MAX	UNITS
Supply Voltage	V_{CC}			3		36	V
Supply Current	I_{CC}	$I_{LOAD} = 0A$, excludes I_{SIGN} ; $V_{CC} = 3V$ to $20V$			20	48	μA
Input Offset Voltage (Note 2)	V_{OS}	MAX472C				120	μV
		MAX472E				140	
Input Bias Current	I_{RG1}, I_{RG2}				20	35	μA
Input Bias-Current Matching	I_{OS}	$I_{RG1} - I_{RG2}$			± 0.4	± 3.0	μA
OUT Current Accuracy	I_{RG}/I_{OUT}	$V_{SENSE} = 100mV$, $V_{CC} = 10V$ (Note 3)	MAX472C			± 2	%
			MAX472E			± 2.5	
No-Load OUT Error		$V_{CC} = 10V$, $V_{SENSE} = 0V$	MAX472C			2.5	μA
			MAX472E			3	
Low-Level OUT Error		$V_{CC} = 10V$, $V_{SENSE} = 3mV$	MAX472C			± 2.5	μA
			MAX472E			± 3.0	
Power-Supply Rejection Ratio	PSRR	$3V \leq V_{CC} \leq 36V$, $V_{SENSE} = 100mV$				0.1	%/V
SIGN Threshold (V_{SENSE} required to switch SIGN)		$V_{CC} = 10V$	MAX472C		60	120	μV
			MAX472E		60	140	
SIGN Output Leakage Current		$V_{SIGN} = 36V$				1.0	μA
SIGN Output Sink Current		$V_{SIGN} = 0.3V$		0.1			mA
Shutdown Supply Current	$I_{CC}(SHDN)$	$V_{SHDN} = 2.4V$; $V_{CC} = 3V$ to $20V$			1.5	18.0	μA
SHDN Input Low Voltage	V_{IL}					0.3	V
SHDN Input Low Current	I_{IL}	$V_{SHDN} = 0V$				1.0	μA
SHDN Input High Voltage	V_{IH}			2.4			V
SHDN Input High Current	I_{IH}	$V_{SHDN} = 2.4V$				1.0	μA
OUT Output Voltage Range	V_{OUT}			0		$V_{CC} - 1.5$	V
OUT Output Resistance	R_{OUT}	$I_{OUT} = 1.5mA$		1	3		$M\Omega$
OUT Rise, Fall Time	t_R, t_F	$V_{SENSE} = 5mV$ to $150mV$, $R_{OUT} = 2k\Omega$, $C_{OUT} = 50pF$, 10% to 90%			4		μs
OUT Settling Time to 1% of Final Value	t_s	$V_{SENSE} = 5mV$ to $150mV$, $R_{OUT} = 2k\Omega$, $C_{OUT} = 50pF$			15		μs
Maximum Output Current	I_{OUT}			1.5			mA

Note 2: V_{OS} is defined as the input voltage (V_{SENSE}) required to give minimum I_{OUT} .

Note 3: V_{SENSE} is the voltage across the sense resistor.

Precision, High-Side Current-Sense Amplifiers

Typical Operating Characteristics

(Typical Operating Circuit (MAX471) or circuit of Figure 4, $R_{G1} = R_{G2} = 200\Omega$, $R_{OUT} = 2k\Omega$ (MAX472), $T_A = +25^\circ\text{C}$, unless otherwise noted.)

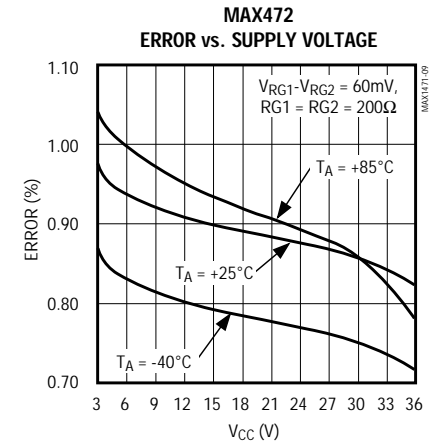
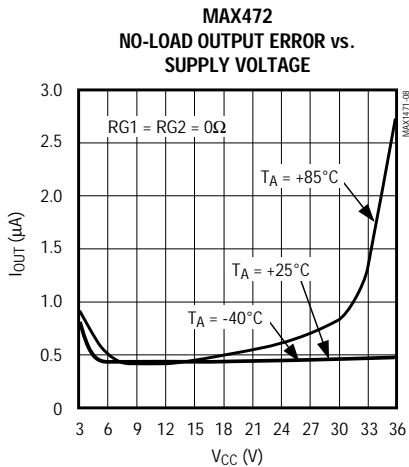
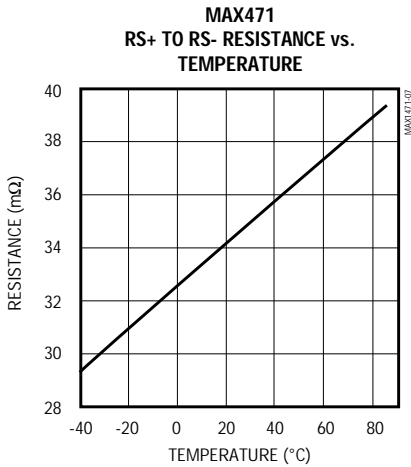
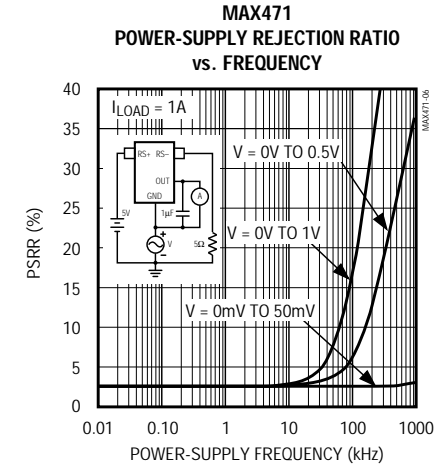
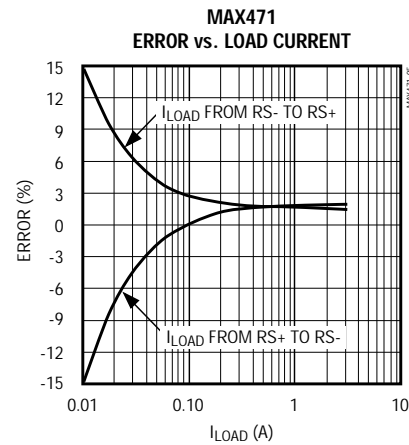
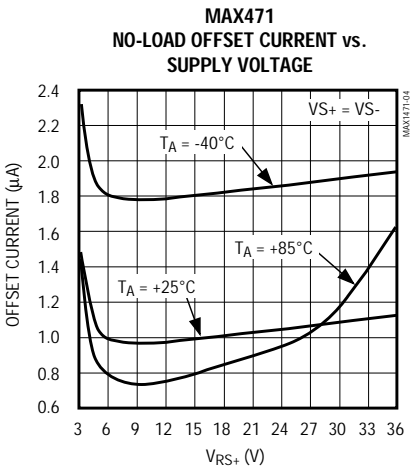
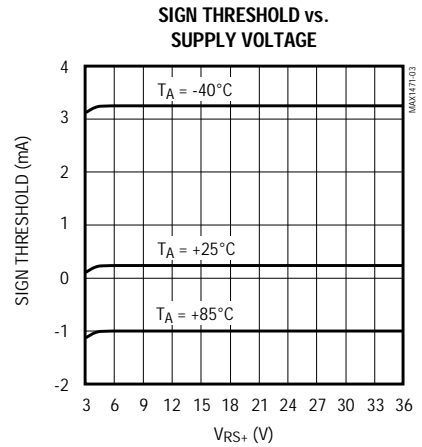
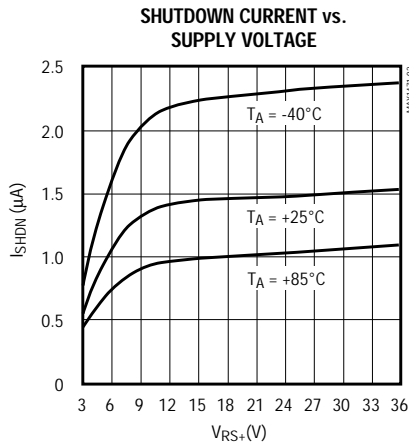
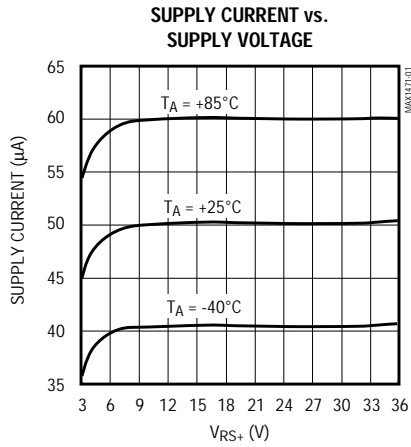

Precision, High-Side Current-Sense Amplifiers

MAX471/MAX472

Typical Operating Characteristics (continued)

(Typical Operating Circuit (MAX471) or circuit of Figure 4, $R_{G1} = R_{G2} = 200\Omega$, $R_{OUT} = 2k\Omega$ (MAX472), $T_A = +25^\circ\text{C}$, unless otherwise noted.)

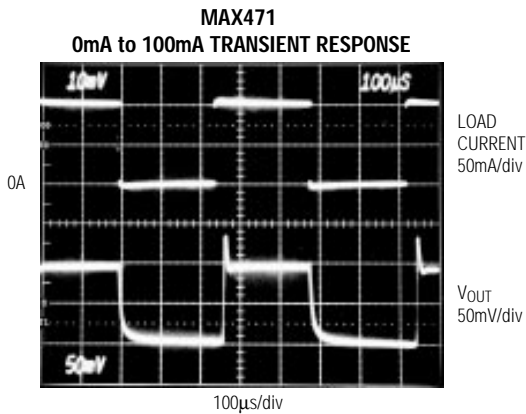
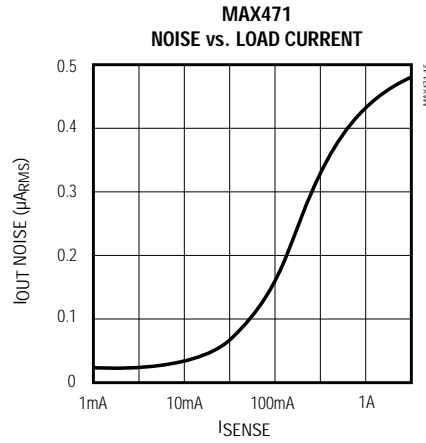
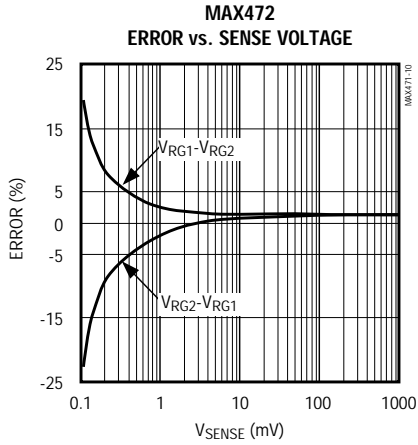

$V_{CC} = 10\text{V}$, $R_{OUT} = 2k\Omega$ 1%, SIGN PULL-UP = $50k\Omega$ 1%

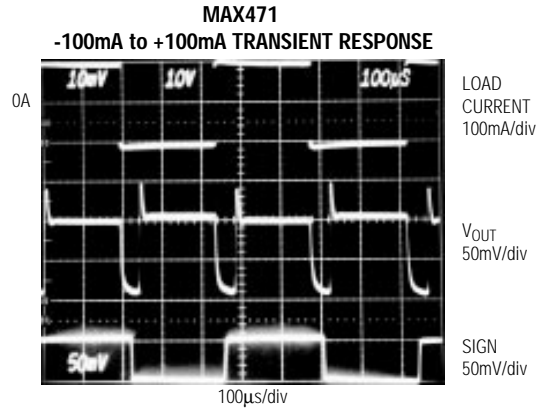

$V_{CC} = 10\text{V}$, $R_{OUT} = 2k\Omega$ 1%, SIGN PULL-UP = $50k\Omega$ 1%

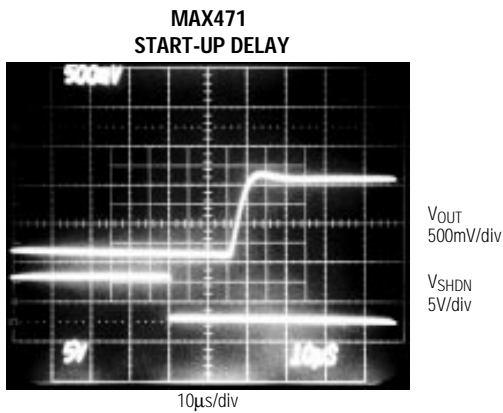

I_{LOAD} = 1A, $R_{OUT} = 2k\Omega$ 1%

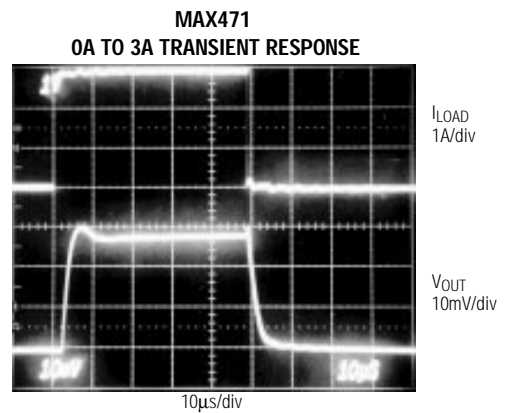

$R_{OUT} = 2k\Omega$ 1%

Precision, High-Side Current-Sense Amplifiers

Pin Description

PIN		NAME	FUNCTION
MAX471	MAX472		
1	1	SHDN	Shutdown. Connect to ground for normal operation. When high, supply current is less than 5µA.
2, 3	—	RS+	Battery (or power) side of the internal current-sense resistor. The "+" indicates direction of flow for SIGN output only. Connect pins 2 and 3 together at the package.
—	2	N.C.	No Connect—no internal connection
—	3	RG1	Gain Resistor. Connect to battery side of current-sense resistor through the gain resistor.
4	4	GND	Ground or Battery Negative Terminal
5	5	SIGN	An open-collector logic output. For the MAX471, a low level indicates current is flowing from RS- to RS+. For the MAX472, a low level indicates a negative V _{SENSE} (see Figure 2). SIGN is high impedance when SHDN is high. Leave open if SIGN is not needed.
6, 7	—	RS-	Load side of the internal current-sense resistor. The "-" indicates direction of flow for SIGN output only. Connect pins 6 and 7 together at the package.
—	6	RG2	Gain Resistor. Connect to load side of current-sense resistor through the gain resistor.
—	7	V _{CC}	Power input for MAX472. Connect to sense resistor (R _{SENSE}) junction with RG1.
8	8	OUT	Current output that is proportional to the magnitude of the sensed current flowing through R _{SENSE} . A 2kΩ resistor from this pin to ground will result in a voltage equal to 1V/Amp of sensed current in the MAX471.

Detailed Description

The MAX471 and MAX472 current-sense amplifier's unique topology allows a simple design to accurately monitor current flow. The MAX471/MAX472 contain two amplifiers operating as shown in Figures 1 and 2. The battery/load current flows from RS+ to RS- (or vice versa) through R_{SENSE}. Current flows through either RG1 and Q1 or RG2 and Q2, depending on the sense-resistor current direction. Internal circuitry, not shown in Figures 1 and 2, prevents Q1 and Q2 from turning on at the same time. The MAX472 is identical to the MAX471, except that R_{SENSE} and gain-setting resistors RG1 and RG2 are external (Figure 2).

To analyze the circuit of Figure 1, assume that current flows from RS+ to RS- and that OUT is connected to GND through a resistor. In this case, amplifier A1 is active and output current I_{OUT} flows from the emitter of Q1. Since no current flows through RG2 (Q2 is off), the negative input of A1 is equal to V_{SOURCE} - (I_{LOAD} × R_{SENSE}). The open-loop gain of A1 forces its positive input to essentially the same level as the negative input. Therefore, the drop across RG1 equals I_{LOAD} × R_{SENSE}. Then, since I_{OUT} flows through Q1 and RG (ignoring the extremely low base currents), I_{OUT} × RG1 = I_{LOAD} × R_{SENSE}, or:

$$I_{OUT} = (I_{LOAD} \times R_{SENSE}) / RG1$$

Current Output

The output voltage equation for the MAX471/MAX472 is given below. In the MAX471, the current-gain ratio has been preset to 500µA/A so that an output resistor (R_{OUT}) of 2kΩ yields 1V/A for a full-scale value of +3V at ±3A. Other full-scale voltages can be set with different R_{OUT} values, but the output voltage can be no greater than V_{RS+} - 1.5V for the MAX471 or V_{RG-} - 1.5V for the MAX472.

$$V_{OUT} = (R_{SENSE} \times R_{OUT} \times I_{LOAD}) / RG$$

where V_{OUT} = the desired full-scale output voltage, I_{LOAD} = the full-scale current being sensed, R_{SENSE} = the current-sense resistor, R_{OUT} = the voltage-setting resistor, and RG = the gain-setting resistor (RG = RG1 = RG2).

The above equation can be modified to determine the R_{OUT} required for a particular full-scale range:

$$R_{OUT} = (V_{OUT} \times RG) / (I_{LOAD} \times R_{SENSE})$$

For the MAX471, this reduces to:

$$R_{OUT} = V_{OUT} / (I_{LOAD} \times 500\mu A/A)$$

OUT is a high-impedance current-source output that can be connected to other MAX471/MAX472 OUT pins

Precision, High-Side Current-Sense Amplifiers

MAX471/MAX472

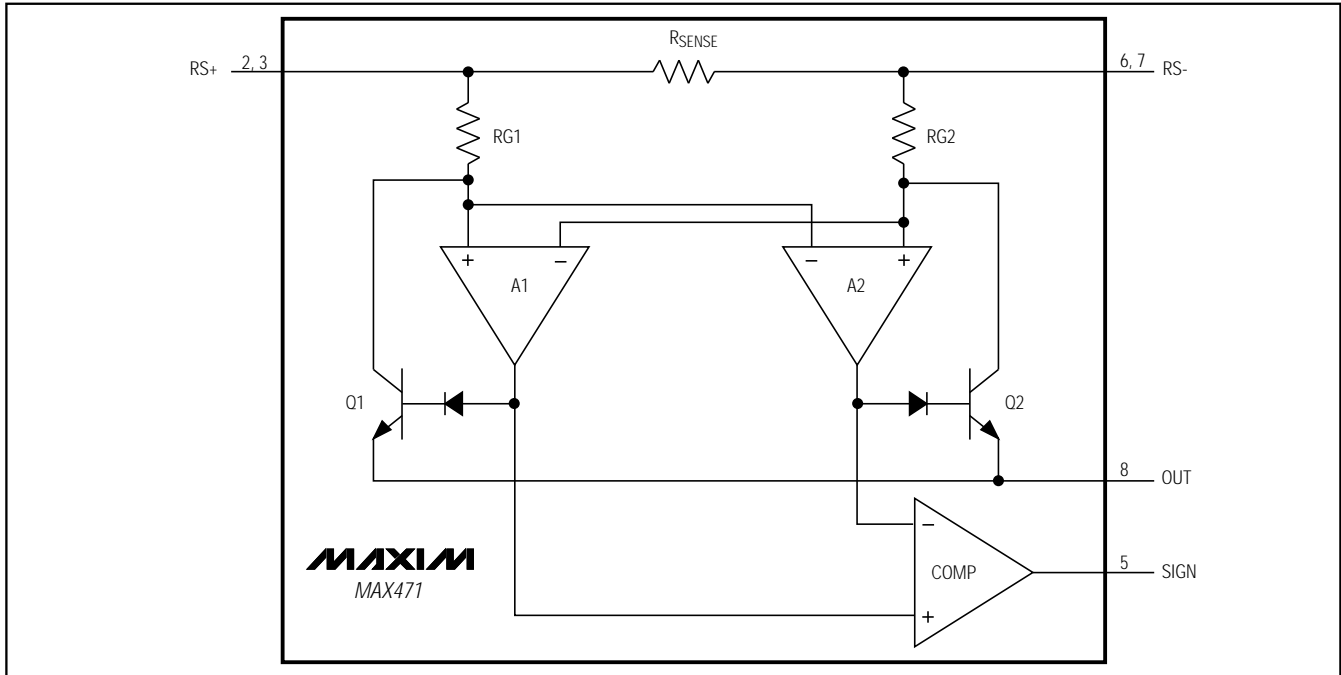

Figure 1. MAX471 Functional Diagram

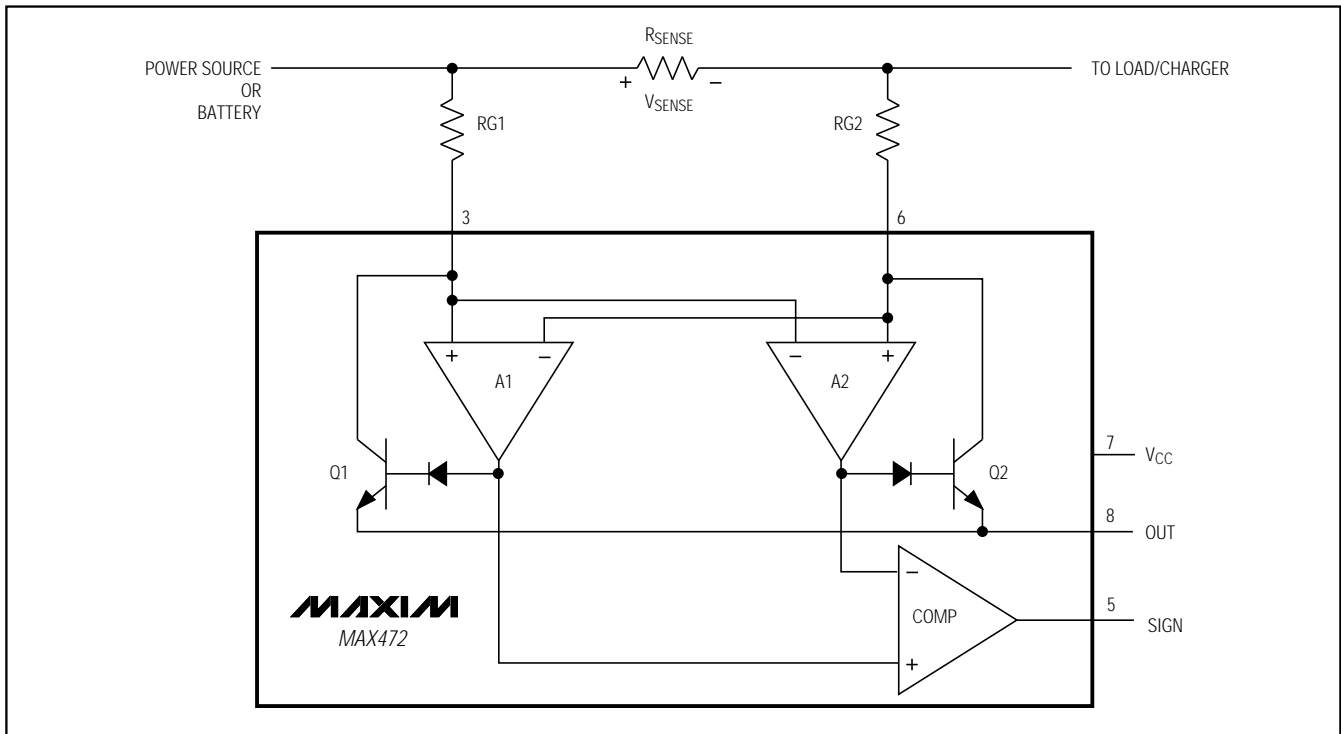

Figure 2. MAX472 Functional Diagram

Precision, High-Side Current-Sense Amplifiers

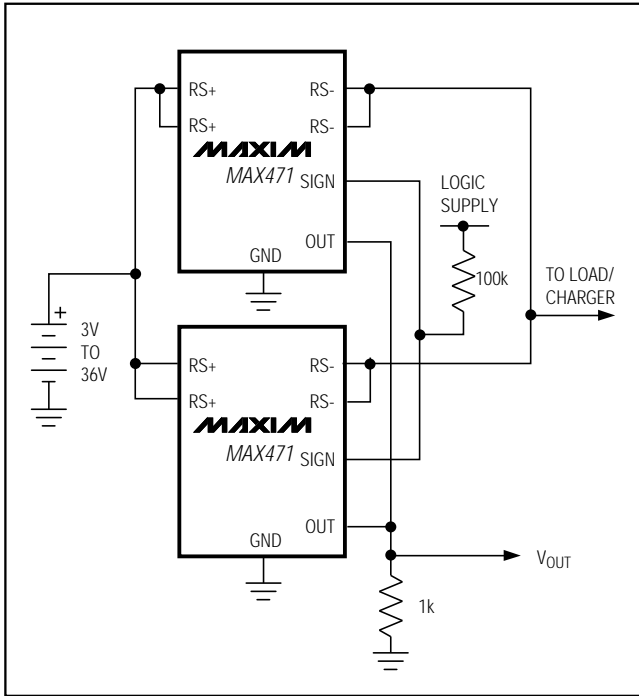

Figure 3. Paralleling MAX471s to Sense Higher Load Current

for current summing. A single scaling resistor is required when summing OUT currents from multiple devices (Figure 3). Current can be integrated by connecting OUT to a capacitive load.

SIGN Output

The current at OUT indicates magnitude. The SIGN output indicates the current's direction. Operation of the SIGN comparator is straightforward. When Q1 (Figures 1 and 2) conducts, the output of A1 is high while A2's output is zero. Under this condition, a high SIGN output indicates positive current flow (from RS+ to RS-). In battery-operated systems, this is useful for determining whether the battery is charging or discharging. The SIGN output may not correctly indicate if the load current is such that I_{OUT} is less than $3.5\mu A$. The MAX471's SIGN output accurately indicates the direction of current flow for load currents greater than 7mA.

SIGN is an open-collector output (sinks current only), allowing easy interface with logic circuits powered from any voltage. Connect a $100k\Omega$ pull-up resistor from SIGN to the logic supply. The convention chosen for the polarity of the SIGN output ensures that it draws no current when the battery is being discharged. If current direction is not needed, float the SIGN pin.

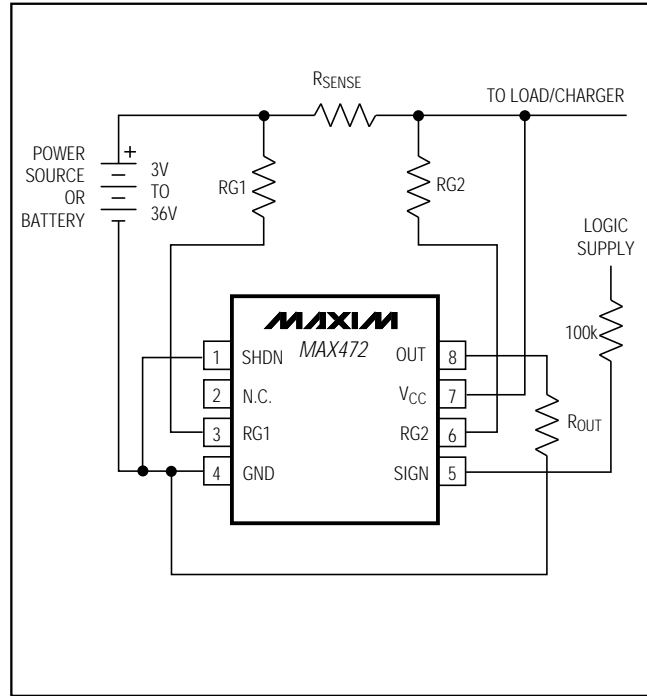

Figure 4. MAX472 Standard Application Circuit

Shutdown

When SHDN is high, the MAX471/MAX472 are shut down and consume less than $18\mu A$. In shutdown mode, SIGN is high impedance and OUT turns off.

Applications Information

MAX471

The MAX471 obtains its power from the RS- pin. This includes MAX471 current consumption in the total system current measured by the MAX471. The small drop across RSENSE does not affect the MAX471's performance.

Resistor Selection

Since OUT delivers a current, an external voltage gain-setting resistor (R_{OUT} to ground) is required at the OUT pin in order to get a voltage. RSENSE is internal to the MAX471. RG1 and RG2 are factory trimmed for an output current ratio (output current to load current) of $500\mu A/A$. Since they are manufactured of the same material and in very close proximity on the chip, they provide a high degree of temperature stability. Choose R_{OUT} for the desired full-scale output voltage up to RS- - 1.5V (see the *Current Output* section).

Precision, High-Side Current-Sense Amplifiers

Peak Sense Current

The MAX471's maximum sense current is 3A_{RMS}. For power-up, fault conditions, or other infrequent events, larger peak currents are allowed, provided they are short—that is, within a safe operating region, as shown in Figure 5.

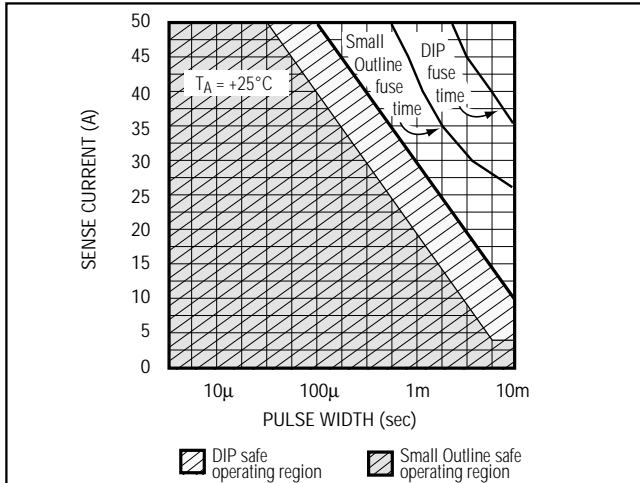

Figure 5. MAX471 Pulse Current Safe Operation for 10,000 Pulses and Fuse Time for Continuous Current. Pulse tests done with 250mW average power dissipation.

MAX472

R_{SENSE}, R_{G1}, and R_{G2} are externally connected on the MAX472. V_{CC} can be connected to either the load/charge or power-source/battery side of the sense resistor. Connect V_{CC} to the load/charge side of R_{SENSE} if you want to include the MAX472 current drain in the measured current.

Suggested Component Values for Various Applications

The general circuit of Figure 4 is useful in a wide variety of applications. It can be used for high-current applications (greater than 3A), and also for those where the full-scale load current is less than the 3A of the MAX471.

Table 1. Suggested Component Values for the MAX472

FULL-SCALE LOAD CURRENT, I _{SENSE} (A)	CURRENT-SENSE RESISTOR, R _{SENSE} (mΩ)	GAIN-SETTING RESISTORS, R _{G1} = R _{G2} (Ω)	OUTPUT RESISTOR, R _{OUT} (kΩ)	FULL-SCALE OUTPUT VOLTAGE, V _{OUT} (V)	SCALE FACTOR, V _{OUT} /I _{SENSE} (V/A)	TYPICAL ERROR AT X% OF FULL LOAD (%)		
						1%	10%	100%
0.1	500	200	10	2.5	25	14	2.5	0.9
1	50	200	10	2.5	2.5	14	2.5	0.9
5	10	100	5	2.5	0.5	13	2.0	1.1
10	5	50	2	2	0.2	12	2.0	1.6

Table 1 shows suggested component values and indicates the resulting scale factors for various applications required to sense currents from 100mA to 10A.

Higher or lower sense-current circuits can also be built. Select components and calculate circuit errors using the guidelines and formulas in the following section.

R_{SENSE}

Choose R_{SENSE} based on the following criteria:

- Voltage Loss:** A high R_{SENSE} value will cause the power-source voltage to degrade through IR loss. For least voltage loss, use the lowest R_{SENSE} value.
- Accuracy:** A high R_{SENSE} value allows lower currents to be measured more accurately. This is because offsets become less significant when the sense voltage is larger.
- Efficiency and Power Dissipation:** At high current levels, the I²R losses in R_{SENSE} may be significant. Take this into consideration when choosing the resistor value and power dissipation (wattage) rating. Also, if the sense resistor is allowed to heat up excessively, its value may drift.
- Inductance:** If there is a large high-frequency component to I_{SENSE}, you will want to keep inductance low. Wire-wound resistors have the highest inductance, while metal film is somewhat better. Low-inductance metal-film resistors are available. Instead of being spiral wrapped around a core, as in metal-film or wire-wound resistors, these are a straight band of metal. They are made in values under 1Ω.
- Cost:** If the cost of R_{SENSE} becomes an issue, you may want to use an alternative solution, as shown in Figure 6. This solution uses the PC board traces to create a sense resistor. Because of the inaccuracies of the copper "resistor," you will need to adjust the full-scale current value with a potentiometer. Also, the resistance temperature coefficient of copper is fairly high (approximately 0.4%/°C), so systems that experience a wide temperature variance should take this into account.

Precision, High-Side Current-Sense Amplifiers

In Figure 6, assume the load current to be measured is 10A and that you have determined a 0.3 inch wide, 2 ounce copper to be appropriate. The resistivity of 0.1 inch wide, 2 ounce copper is $30\text{m}\Omega/\text{ft}$ (see Note 4). For 10A you may want $R_{\text{SENSE}} = 5\text{m}\Omega$ for a 50mV drop at full scale. This resistor will require about 2 inches of 0.1 inch wide copper trace.

RG1 and RG2

Once R_{SENSE} is chosen, R_{G1} and R_{G2} can be chosen to define the current-gain ratio ($R_{\text{SENSE}}/R_{\text{G}}$). Choose $R_{\text{G}} = R_{\text{G1}} = R_{\text{G2}}$ based on the following criteria:

- 1 Ω Input Resistance.** The minimum R_{G} value is limited by the 1Ω input resistance, and also by the output current limitation (see below). As R_{G} is reduced, the input resistance becomes a larger portion of the total gain-setting resistance. With $R_{\text{G}} = 50\Omega$, the input resistance produces a 2% difference between the expected and actual current-gain ratio. This is a gain error that does not affect linearity and can be removed by adjusting R_{G} or R_{OUT} .
- Efficiency.** As R_{G} is reduced, I_{OUT} gets larger for a given load current. Power dissipated in R_{OUT} is not going to the load, and therefore reduces overall efficiency. This is significant only when the sense current is small.
- Maximum Output Current Limitation.** I_{OUT} is limited to 1.5mA, requiring $R_{\text{G}} \geq V_{\text{SENSE}} / 1.5\text{mA}$. For $V_{\text{SENSE}} = 60\text{mV}$, R_{G} must be $\geq 40\Omega$.
- Headroom.** The MAX472 requires a minimum of 1.5V between the lower of the voltage at R_{G1} or R_{G2} (V_{RG_-}) and V_{OUT} . As R_{G} becomes larger, the voltage drop across R_{G} also becomes larger for a given I_{OUT} . This voltage drop further limits the maximum full-scale V_{OUT} . Assuming the drop across R_{SENSE} is small and V_{CC} is connected to either side of R_{SENSE} , $V_{\text{OUT}}(\text{max}) = V_{\text{CC}} - (1.5\text{V} + I_{\text{OUT}}(\text{max}) \times R_{\text{G}})$.
- Output Offset Error at Low Load Currents.** Large R_{G} values reduce I_{OUT} for a given load current. As I_{OUT} gets smaller, the $2.5\mu\text{A}$ max output offset-error current becomes a larger part of the overall output current. Keeping the gain high by choosing a low value for R_{G} minimizes this offset error.
- Input Bias Current and Input Bias Current Mismatching.** The size of R_{G} also affects the errors introduced by the input bias and input bias mismatching currents. After selecting the ratio, check to

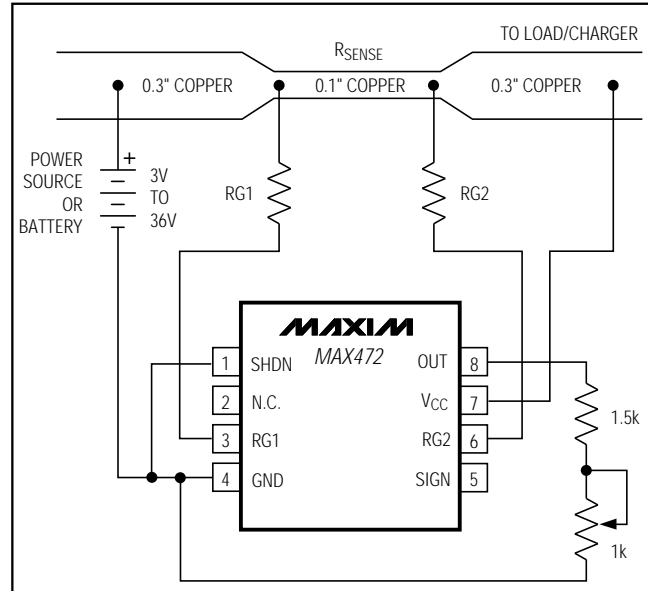

Figure 6. MAX472 Connections Showing Use of PC Board Trace

make sure R_{G} is small enough that I_{B} and I_{OS} do not add any appreciable errors. The full-scale error is given by:

$$\% \text{ Error} = \frac{(R_{\text{G1}} - R_{\text{G2}}) \times I_{\text{B}} + I_{\text{OS}} \times R_{\text{G}}}{I_{\text{FS}} \times R_{\text{SENSE}}} \times 100$$

where R_{G1} and R_{G2} are the gain resistors, I_{B} is the bias current, I_{OS} is the bias-current mismatch, I_{FS} is the full-scale current, and R_{SENSE} is the sense resistor.

Assuming a 5A load current, $10\text{m}\Omega$ R_{SENSE} , and 100Ω R_{G} , the current-gain ratio is $100\mu\text{A}/\text{A}$, yielding a full-scale I_{OUT} of $500\mu\text{A}$. Using the maximum values for I_{B} ($20\mu\text{A}$) and I_{OS} ($2\mu\text{A}$), and 1% resistors for R_{G1} and R_{G2} ($R_{\text{G1}} - R_{\text{G2}} = 2\Omega$), the worst-case error at full scale calculates to:

$$\frac{2\Omega \times 20\mu\text{A} + 100\Omega \times 2\mu\text{A}}{5\text{m}\Omega \times 5\text{A}} = 0.48\%$$

The error may be reduced by: a) better matching of R_{G1} and R_{G2} , b) increasing R_{SENSE} , or c) decreasing R_{G} .

Current-Sense Adjustment (Resistor Range, Output Adjust)

Choose R_{OUT} after selecting R_{SENSE} , R_{G1} , and R_{G2} . Choose R_{OUT} to obtain the full-scale voltage you

Note 4: Printed Circuit Design, by Gerald L. Ginsberg; McGraw-Hill, Inc.; page 185.

Precision, High-Side Current-Sense Amplifiers

MAX471/MAX472

require, given the full-scale I_{OUT} determined by R_{SENSE} , $RG1$, and $RG2$. The high compliance of OUT permits using R_{OUT} values up to $10k\Omega$ with minimal error. Values above $10k\Omega$ are not usually recommended. The impedance of OUT 's load (e.g., the input of an op amp or ADC) must be much greater than R_{OUT} (e.g., $100 \times R_{OUT}$) to avoid degrading the measurement accuracy.

High-Current Measurement

The MAX472 can achieve higher current measurements than the MAX471 can. Low-value sense resistors may be paralleled to obtain even lower values, or the PC board trace may be adjusted for any value.

An alternative method is to connect several MAX471s in parallel and connect the high-impedance current-source OUT pins together to indicate the total system current (Figure 3). Pay attention to layout to ensure equal IR drops in the paralleled connection. This is necessary to achieve equal current sharing.

Power-Supply Bypassing and Grounding

The MAX471 has been designed as a "high side" (positive terminal) current monitor to ease the task of grounding any battery charger, thermistor, etc. that may be a part of the battery pack. Grounding the MAX471 requires no special precautions; follow the same cautionary steps that apply to the system as a whole. High-current systems can experience large voltage drops across a ground plane, and this drop may add to or subtract from V_{OUT} . For highest current-measurement accuracy, use a single-point "star" ground.

The MAX471/MAX472 require no special bypassing, and respond quickly to transient changes in line current. If the noise at OUT caused by these transients is a problem, you may want to place a $1\mu F$ capacitor at the OUT pin to ground. You can also place a large capacitor at the $RS-$ terminal (or "load" side of the MAX472) to decouple the load and, thereby, reduce the current transients. These capacitors are not required for MAX471/MAX472 operation or stability, and their use will not degrade performance.

For the MAX472, the $RG1$ and $RG2$ inputs can be filtered by placing a capacitor (e.g., $1\mu F$) between them to average the sensed current.

MAX471 Layout

The MAX471 must be soldered in place, since sockets can cause uneven current sharing between the $RS+$ pins (pins 2 and 3) and the $RS-$ pins (pins 6 and 7), resulting in typical errors of 0.5%.

In order to dissipate sense-resistor heat from large sense currents, solder the $RS+$ pins and the $RS-$ pins to large copper traces. Keep the part away from other heat-generating devices. This procedure will ensure continuous power dissipation rating.

Precision, High-Side Current-Sense Amplifiers

___ Pin Configurations (continued)

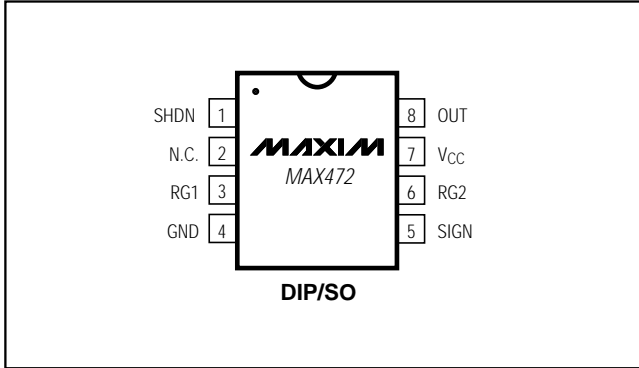

Maxim cannot assume responsibility for use of any circuitry other than circuitry entirely embodied in a Maxim product. No circuit patent licenses are implied. Maxim reserves the right to change the circuitry and specifications without notice at any time.

12 _____ Maxim Integrated Products, 120 San Gabriel Drive, Sunnyvale, CA 94086 (408) 737-7600

Looking for pricing, stock, or lifecycle information?

Click below to explore more details on WIN SOURCE:

 [View MAX472EPA on WIN SOURCE](#)

 [Maxim Integrated](#) Information

Optimize Your Supply Chain with WIN SOURCE Solutions

-  Global Sourcing Solution
-  Obsolete Management
-  Cost Control Management
-  Shortage Management
-  Alternative Solution
-  Excess Inventory Management