



**THE DATASHEET OF  
DS25MB100TSQX/NOPB**



# DS25MB100 2.5 Gbps 2:1/1:2 CML Mux/Buffer With Transmit Pre-Emphasis and Receive Equalization

## 1 Features

- 2:1 Multiplexer and 1:2 Buffer
- 0.25-Gbps to 2.5-Gbps Fully Differential Data Paths
- Fixed Input Equalization
- Programmable Output Pre-Emphasis
- Independent Pre-Emphasis Controls
- Programmable Loopback Modes
- On-Chip Terminations
- ESD Rating of 6-kV HBM
- 3.3-V Supply
- Low power, 0.45 W Typical
- Lead-Less WQFN-36 Package
- -40°C to +85°C Operating Temperature Range

## 2 Applications

- Backplane Drivers or Cable Driver
- Redundancy and Signal Conditioning Applications
- CPRI/OBSAI

## 3 Description

The DS25MB100 device is a signal conditioning 2:1 multiplexer and 1:2 fan-out buffer designed for use in backplane-redundancy or cable driving applications. Signal conditioning features include continuous time linear equalization (CTLE) and programmable output pre-emphasis that enable data communication in FR4 backplane up to 2.5 Gbps. Each input stage has a fixed equalizer to reduce ISI distortion from board traces.

All output drivers have four selectable levels of pre-emphasis to compensate for transmission losses from long FR4 backplane or cable attenuation reducing deterministic jitter. The pre-emphasis levels can be independently controlled for the line-side and switch-side drivers. The internal loopback paths from switch-side input to switch-side output enable at-speed system testing. All receiver inputs are internally terminated with 100-Ω differential terminating resistors. All driver outputs are internally terminated with 50-Ω terminating resistors to  $V_{CC}$ .

### Device Information<sup>(1)</sup>

PART NUMBER	PACKAGE	BODY SIZE (NOM)
DS25MB100	WQFN (36)	6.00 mm x 6.00 mm

(1) For all available packages, see the orderable addendum at the end of the data sheet.

### Simplified Block Diagram

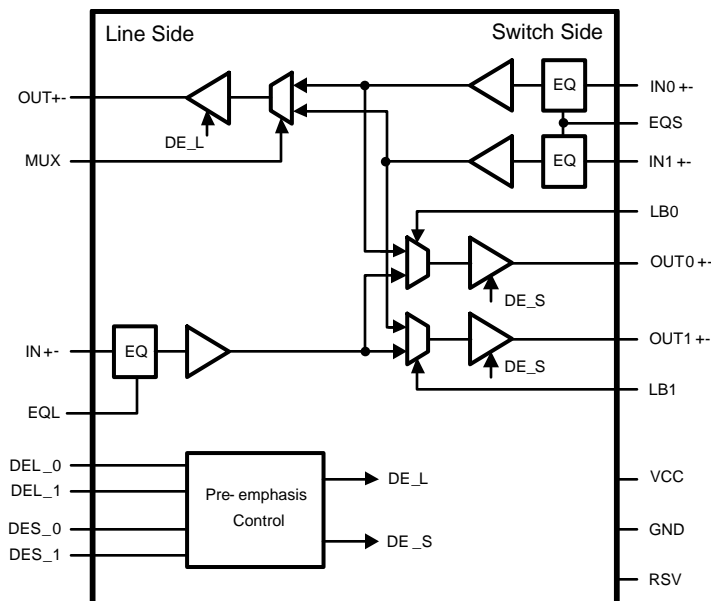

All CML inputs and outputs must be AC coupled for optimal performance.



## Table of Contents

<b>1 Features</b> ..... 1 <b>2 Applications</b> ..... 1 <b>3 Description</b> ..... 1 <b>4 Revision History</b> ..... 2 <b>5 Pin Configuration and Functions</b> ..... 3 <b>6 Specifications</b> ..... 4 6.1 Absolute Maximum Ratings ..... 4 6.2 ESD Ratings ..... 4 6.3 Recommended Operating Conditions ..... 5 6.4 Thermal Information ..... 5 6.5 Electrical Characteristics ..... 5 6.6 Switching Characteristics ..... 7 6.7 Typical Characteristics ..... 8 <b>7 Parameter Measurement Information</b> ..... 8 <b>8 Detailed Description</b> ..... 9 8.1 Overview ..... 9	8.2 Functional Block Diagram ..... 9 8.3 Feature Description ..... 9 <b>9 Application and Implementation</b> ..... 12 9.1 Application Information ..... 12 9.2 Typical Application ..... 12 <b>10 Power Supply Recommendations</b> ..... 16 <b>11 Layout</b> ..... 16 11.1 Layout Guidelines ..... 16 11.2 Layout Example ..... 16 <b>12 Device and Documentation Support</b> ..... 18 12.1 Documentation Support ..... 18 12.2 Community Resources ..... 18 12.3 Trademarks ..... 18 12.4 Electrostatic Discharge Caution ..... 18 12.5 Glossary ..... 18 <b>13 Mechanical, Packaging, and Orderable Information</b> ..... 18
---	---

## 4 Revision History

NOTE: Page numbers for previous revisions may differ from page numbers in the current version.

<b>Changes from Revision G (April 2013) to Revision H</b>	<b>Page</b>
<ul style="list-style-type: none"> <li>• Added <i>ESD Ratings</i> table, <i>Feature Description</i> section, <i>Device Functional Modes</i>, <i>Application and Implementation</i> section, <i>Power Supply Recommendations</i> section, <i>Layout</i> section, <i>Device and Documentation Support</i> section, and <i>Mechanical, Packaging, and Orderable Information</i> section. ....</li> </ul>	1
<ul style="list-style-type: none"> <li>• Changed thermal information per latest modeling results .....</li> </ul>	5
<ul style="list-style-type: none"> <li>• Changed board trace attenuation estimate, per recent measurement .....</li> </ul>	14

<b>Changes from Revision F (April 2013) to Revision G</b>	<b>Page</b>
<ul style="list-style-type: none"> <li>• Changed layout of National Data Sheet to TI format .....</li> </ul>	1

## 5 Pin Configuration and Functions

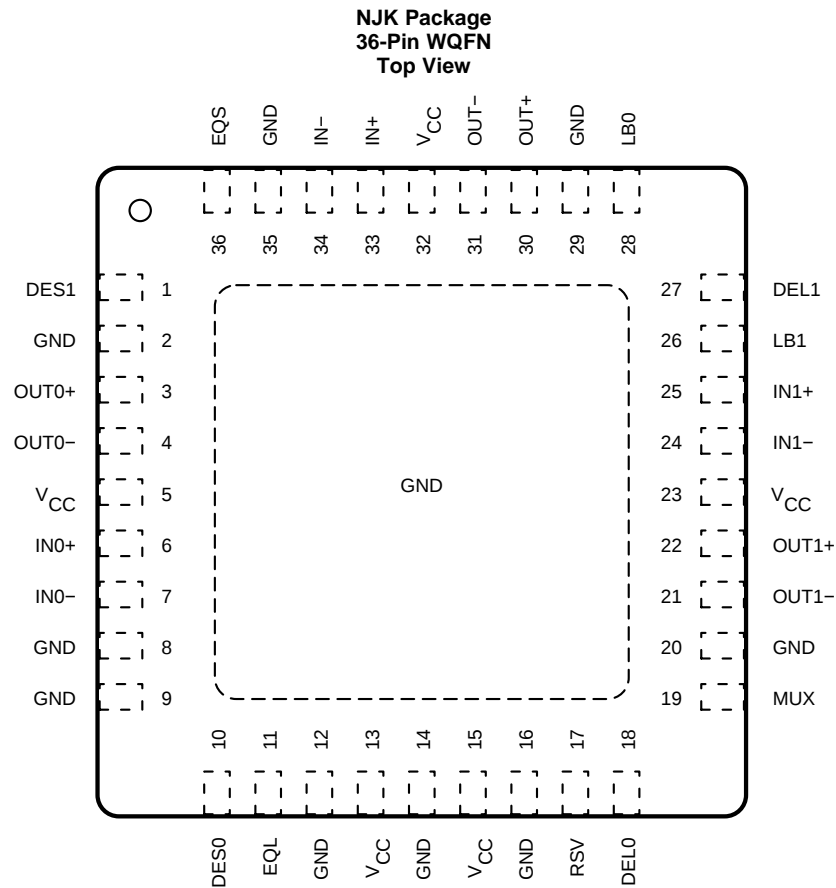

**Pin Functions<sup>(1)</sup>**

PIN		TYPE <sup>(2)</sup>	DESCRIPTION
NAME	NO.		
<b>LINE SIDE HIGH SPEED DIFFERENTIAL IO's</b>			
IN+	33	I	Inverting and noninverting differential inputs at the line side. IN+ and IN- have an internal 50 $\Omega$ connected to an internal reference voltage. See <a href="#">Figure 8</a> .
IN-	34	I	
OUT+	30	O	Inverting and noninverting differential outputs at the line side. OUT+ and OUT- have an internal 50 $\Omega$ connected to $V_{CC}$ . See <a href="#">Figure 7</a> .
OUT-	31	O	
<b>SWITCH SIDE HIGH SPEED DIFFERENTIAL IO's</b>			
IN0+	6	I	Inverting and noninverting differential inputs to the mux at the switch side. IN0+ and IN0- have an internal 50 $\Omega$ connected to an internal reference voltage. See <a href="#">Figure 8</a> .
IN0-	7	I	
IN1+	25	I	Inverting and noninverting differential inputs to the mux at the switch side. IN1+ and IN1- have an internal 50 $\Omega$ connected to an internal reference voltage. See <a href="#">Figure 8</a> .
IN1-	24	I	
OUT0+	3	O	Inverting and noninverting differential outputs at the switch side. OUT0+ and OUT0- have an internal 50 $\Omega$ connected to $V_{CC}$ . See <a href="#">Figure 7</a> .
OUT0-	4	O	
OUT1+	22	O	Inverting and noninverting differential outputs at the switch side. OUT1+ and OUT1- have an internal 50 $\Omega$ connected to $V_{CC}$ . See <a href="#">Figure 7</a> .
OUT1-	21	O	
<b>CONTROL (3.3-V LVCMOS)</b>			
DEL_0	18	I	DEL_0 and DEL_1 select the output pre-emphasis of the line side drivers (OUT $\pm$ ). DEL_0 and DEL_1 are internally pulled high.
DEL_1	27	I	

(1) All CML Inputs or Outputs must be AC coupled.

(2) I = Input, O = Output, P = Power

**Pin Functions<sup>(1)</sup> (continued)**

PIN		TYPE <sup>(2)</sup>	DESCRIPTION
NAME	NO.		
DES_0 DES_1	10 1	I	DES_0 and DES_1 select the output pre-emphasis of the switch side drivers (OUT0±, OUT1±). DES_0 and DES_1 are internally pulled high.
EQL	11	I	A logic low enables the input equalizer on the line side. EQL is internally pulled high. Default is with EQ disabled.
EQS	36	I	A logic low enables the input equalizer on the switch side. EQS is internally pulled high. Default is with EQ disabled.
LB0	28	I	A logic low at LB0 enables the internal loopback path from IN0± to OUT0±. LB0 is internally pulled high.
LB1	26	I	A logic low at LB1 enables the internal loopback path from IN1± to OUT1±. LB1 is internally pulled high.
MUX	19	I	A logic low at MUX selects IN1±. MUX is internally pulled high. Default state for MUX is IN0±.
RSV	17	I	Reserve pin to support factory testing. This pin can be left open, or tied to GND, or tied to GND through an external pulldown resistor.
<b>POWER</b>			
GND	2, 8, 9, 12, 14, 16, 20, 29, 35	P	Ground reference. Each ground pin must be connected to the ground plane through a low inductance path, typically with a via located as close as possible to the landing pad of the GND pin.
GND_DAP	GND	P	DAP is the metal contact at the bottom side, located at the center of the WQFN package. It must be connected to the GND plane with at least 16 via to lower the ground impedance and improve the thermal performance of the package.
V <sub>CC</sub>	5, 13, 15, 23, 32	P	V <sub>CC</sub> = 3.3 V ± 5%. Each V <sub>CC</sub> pin must be connected to the V <sub>CC</sub> plane through a low inductance path, typically with a via located as close as possible to the landing pad of the V <sub>CC</sub> pin. It is recommended to have a 0.01-μF or 0.1-μF, X7R, size-0402 bypass capacitor from each V <sub>CC</sub> pin to ground plane.

## 6 Specifications

### 6.1 Absolute Maximum Ratings<sup>(1)(2)</sup>

	MIN	MAX	UNIT
Supply voltage (V <sub>CC</sub> )	-0.3	4	V
CMOS/TTL input voltage	-0.3	V <sub>CC</sub> + 0.3	V
CML input/output voltage	-0.3	V <sub>CC</sub> + 0.3	V
Lead temperature	Soldering, 4 seconds		260
Junction temperature			150
Storage temperature, T <sub>stg</sub>	-65	150	°C

- (1) Stresses beyond those listed under *Absolute Maximum Ratings* may cause permanent damage to the device. These are stress ratings only, which do not imply functional operation of the device at these or any other conditions beyond those indicated under *Recommended Operating Conditions*. Exposure to absolute-maximum-rated conditions for extended periods may affect device reliability.
- (2) If Military/Aerospace specified devices are required, please contact the TI Sales Office/Distributors for availability and specifications.

### 6.2 ESD Ratings

		VALUE	UNIT
V <sub>(ESD)</sub>	Electrostatic discharge	Human-body model (HBM), per ANSI/ESDA/JEDEC JS-001 <sup>(1)</sup>	V
		Charged-device model (CDM), per JEDEC specification JESD22-C101 <sup>(2)</sup>	
		Machine model (MM)	

- (1) JEDEC document JEP155 states that 500-V HBM allows safe manufacturing with a standard ESD control process.
- (2) JEDEC document JEP157 states that 250-V CDM allows safe manufacturing with a standard ESD control process.

### 6.3 Recommended Operating Conditions

	MIN	NOM	MAX	UNIT
Supply voltage ( $V_{CC} - GND$ )	3.135	3.3	3.465	V
Supply noise amplitude (10 Hz to 2 GHz)			100	mV <sub>PP</sub>
Ambient temperature	-40		85	°C
Case temperature			100	°C

### 6.4 Thermal Information

THERMAL METRIC <sup>(1)</sup>		DS25MB100	UNIT
		NJK (WQFN)	
		36 PINS	
$R_{\theta JA}$	Junction-to-ambient thermal resistance <sup>(2)</sup>	32.8	°C/W
$R_{\theta JC(top)}$	Junction-to-case (top) thermal resistance	14.3	°C/W
$R_{\theta JB}$	Junction-to-board thermal resistance	6.2	°C/W
$\Psi_{JT}$	Junction-to-top characterization parameter	0.2	°C/W
$\Psi_{JB}$	Junction-to-board characterization parameter	6.1	°C/W
$R_{\theta JC(bot)}$	Junction-to-case (bottom) thermal resistance	1.9	°C/W

- (1) For more information about traditional and new thermal metrics, see the *Semiconductor and IC Package Thermal Metrics* application report, [SPRA953](#).
- (2) Thermal resistances are based on having 16 thermal relief vias on the DAP pad under the 0 airflow condition.

### 6.5 Electrical Characteristics

over recommended operating supply and temperature ranges unless otherwise specified.

PARAMETER		TEST CONDITIONS	MIN	TYP <sup>(1)</sup>	MAX	UNIT	
<b>LVCMOS DC SPECIFICATIONS</b>							
$V_{IH}$	High level input voltage		2		$V_{CC} + 0.3$	V	
$V_{IL}$	Low level input voltage		-0.3		0.8	V	
$I_{IH}$	High level input current	$V_{IN} = V_{CC}$	-10		10	μA	
$I_{IL}$	Low level input current	$V_{IN} = GND$	75	94	124	μA	
$R_{PU}$	Pull-high resistance			35		kΩ	
<b>RECEIVER SPECIFICATIONS</b>							
$V_{ID}$	Differential input voltage range <sup>(2)</sup>	AC-coupled differential signal This parameter is not tested at production	Below 1.25 Gbps		100	1750	mV <sub>P-P</sub>
			Above 1.25 Gbps		100	1560	
$V_{ICM}$	Common-mode voltage at receiver inputs	Measured at receiver inputs reference to ground		1.3		V	
$R_{ITD}$	Input differential termination <sup>(3)</sup>	On-chip differential termination between IN+ or IN-	84	100	116	Ω	

- (1) Typical parameters measured at  $V_{CC} = 3.3$  V,  $T_A = 25^\circ\text{C}$ , and represent most likely parametric norms at the time of product characterization. The typical specifications are not ensured.
- (2) This parameter is ensured by design and/or characterization. It is not tested in production.
- (3) IN+ and IN- are generic names refer to one of the many pairs of complimentary inputs of the DS25MB100. OUT+ and OUT- are generic names refer to one of the many pairs of the complimentary outputs of the DS25MB100. Differential input voltage  $V_{ID}$  is defined as  $|IN+ - IN-|$ . Differential output voltage  $V_{OD}$  is defined as  $|OUT+ - OUT-|$ .

## Electrical Characteristics (continued)

over recommended operating supply and temperature ranges unless otherwise specified.

PARAMETER		TEST CONDITIONS	MIN	TYP <sup>(1)</sup>	MAX	UNIT
<b>DRIVER SPECIFICATIONS</b>						
$V_{ODB}$	Output differential voltage swing without pre-emphasis <sup>(4)</sup>	$R_L = 100\Omega \pm 1\%$ DES_1=DES_0=0 DEL_1=DEL_0=0 Driver pre-emphasis disabled Running K28.7 pattern at 2.5 Gbps See Figure 6 for test circuit.	1100	1300	1500	mV <sub>p-p</sub>
$V_{PE}$	Output pre-emphasis voltage ratio $20 \times \log(V_{ODPE}/V_{ODB})$	$R_L = 100\Omega \pm 1\%$ Running K28.7 pattern at 2.5 Gbps x=S for switch side pre-emphasis control x=L for line side pre-emphasis control See Figure 9 on waveform. See Figure 6 for test circuit.	DEX_[1:0]=00	0		dB
			DEX_[1:0]=01	-3		
			DEX_[1:0]=10	-6		
		DEX_[1:0]=11	-9			
$T_{PE}$	Pre-emphasis width	Tested at -9-dB pre-emphasis level, DEX[1:0]=11 x=S for switch side pre-emphasis control x=L for line side pre-emphasis control See Figure 3 on measurement condition.	125	188	250	ps
$R_{OTSE}$	Output termination <sup>(3)</sup>	On-chip termination from OUT+ or OUT- to $V_{CC}$	42	50	58	$\Omega$
$R_{OTD}$	Output differential termination	On-chip differential termination between OUT+ and OUT-	100			$\Omega$
$\Delta R_{OTS E}$	Mis-match in output termination resistors	Mis-match in output terminations at OUT+ and OUT-			5%	
$V_{OCM}$	Output common-mode voltage		2.7			V
<b>POWER DISSIPATION</b>						
$P_D$	Power dissipation	$V_{DD} = 3.3V$ at 25°C All outputs terminated by $100\Omega \pm 1\%$ . DEL_[1:0]=0, DES_[1:0]=0 Running PRBS 2 <sup>7</sup> -1 pattern at 2.5 Gbps	0.45			W
<b>AC CHARACTERISTICS</b>						
RJ	Device random jitter <sup>(5)</sup>	See Figure 6 for test circuit. Alternating-1-0 pattern EQ and pre-emphasis disabled.	At 0.25 Gbps			2
			At 1.25 Gbps			2
			At 2.5 Gbps			2
DJ	Device deterministic jitter <sup>(6)</sup>	See Figure 6 for test circuit. EQ and pre-emphasis disabled Between 0.25 and 2.5 Gbps with PRBS-7 pattern for DS25MB100 at -40°C to 85°C			35	ps <sub>p-p</sub>
DR	Data rate <sup>(2)</sup>	Tested with alternating 1-0 pattern	0.25		2.5	Gbps

- (4) K28.7 pattern is a 10-bit repeating pattern of K28.7 code group {001111 1000}K28.5 pattern is a 20-bit repeating pattern of +K28.5 and -K28.5 code groups {110000 0101 001111 1010}
- (5) Device output random jitter is a measurement of the random jitter contribution from the device. It is derived by the equation  $\sqrt{R_{J_{OUT}}^2 - R_{J_{IN}}^2}$ , where  $R_{J_{OUT}}$  is the total random jitter measured at the output of the device in ps<sub>rms</sub>,  $R_{J_{IN}}$  is the random jitter of the pattern generator driving the device.
- (6) Device output deterministic jitter is a measurement of the deterministic jitter contribution from the device. It is derived by the equation  $(DJ_{OUT} - DJ_{IN})$ , where  $DJ_{OUT}$  is the total peak-to-peak deterministic jitter measured at the output of the device in ps<sub>p-p</sub>,  $DJ_{IN}$  is the peak-to-peak deterministic jitter of the pattern generator driving the device.

## 6.6 Switching Characteristics

over operating free-air temperature range (unless otherwise noted)

PARAMETER		TEST CONDITIONS	MIN	TYP	MAX	UNIT
$t_R$	Differential low-to-high transition time	Measured with a clock-like pattern at 2.5 Gbps, between 20% and 80% of the differential output voltage. Pre-emphasis disabled. Transition time is measured with fixture as shown in Figure 6, adjusted to reflect the transition time at the output pins.		100		ps
$t_F$	Differential high-to-low transition time			100		ps
$t_{PLH}$	Differential low-to-high propagation delay	Measured at 50% differential voltage from input to output.			1	ns
$t_{PHL}$	Differential high-to-low propagation delay				1	ns
$t_{SKP}$	Pulse skew	$ t_{PHL} - t_{PLH} $			20	ps
$t_{SKO}$	Output skew <sup>(1)</sup>	Difference in propagation delay among data paths in the same device.			100	ps
$t_{SKPP}$	Part-to-part skew	Difference in propagation delay between the same output from devices operating under identical condition.			100	ps
$t_{SM}$	MUX switch time	Measured from $V_{IH}$ or $V_{IL}$ of the MUX-control or loopback control to 50% of the valid differential output.		1.8	6	ns

- (1)  $t_{SKO}$  is the magnitude difference in the propagation delays among data paths. An example is the output skew among data paths from  $IN0_{\pm}$  to  $OUT_{\pm}$  and  $IN1_{\pm}$  to  $OUT_{\pm}$ . Another example is the output skew among data paths from  $IN_{\pm}$  to  $OUT0_{\pm}$  and  $IN_{\pm}$  to  $OUT1_{\pm}$ .  $t_{SKO}$  also refers to the delay skew of the loopback paths of the same port and between similar data paths. An example is the output skew among data paths  $IN0_{\pm}$  to  $OUT0_{\pm}$  and  $IN1_{\pm}$  to  $OUT1_{\pm}$ .

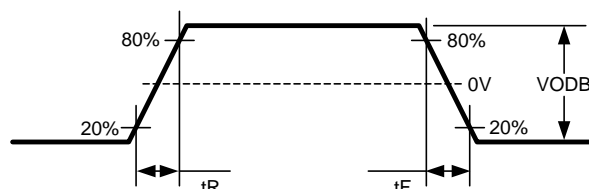

**Figure 1. Driver Output Transition Time**

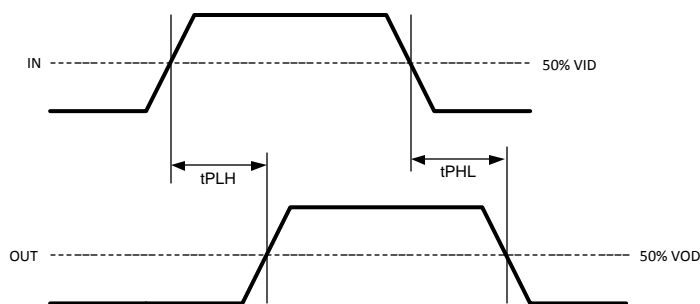

**Figure 2. Propagation Delay from Input to Output**

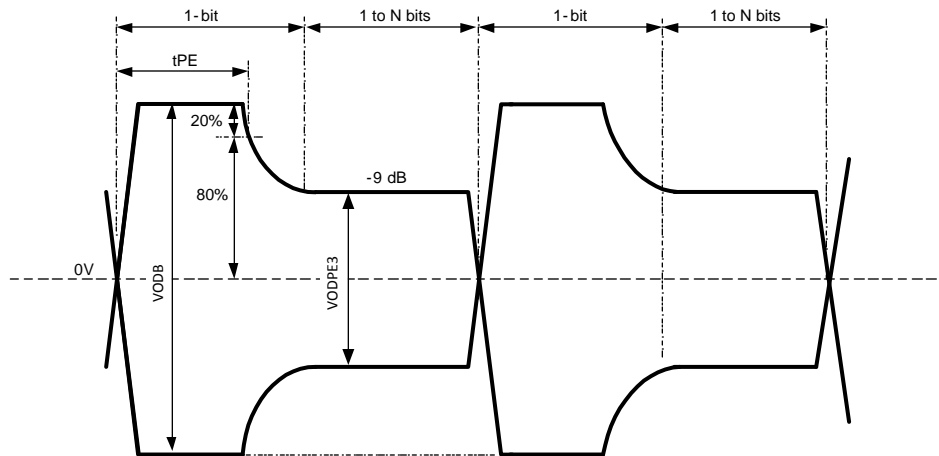

Figure 3. Test Condition for Output Pre-Emphasis Duration

### 6.7 Typical Characteristics

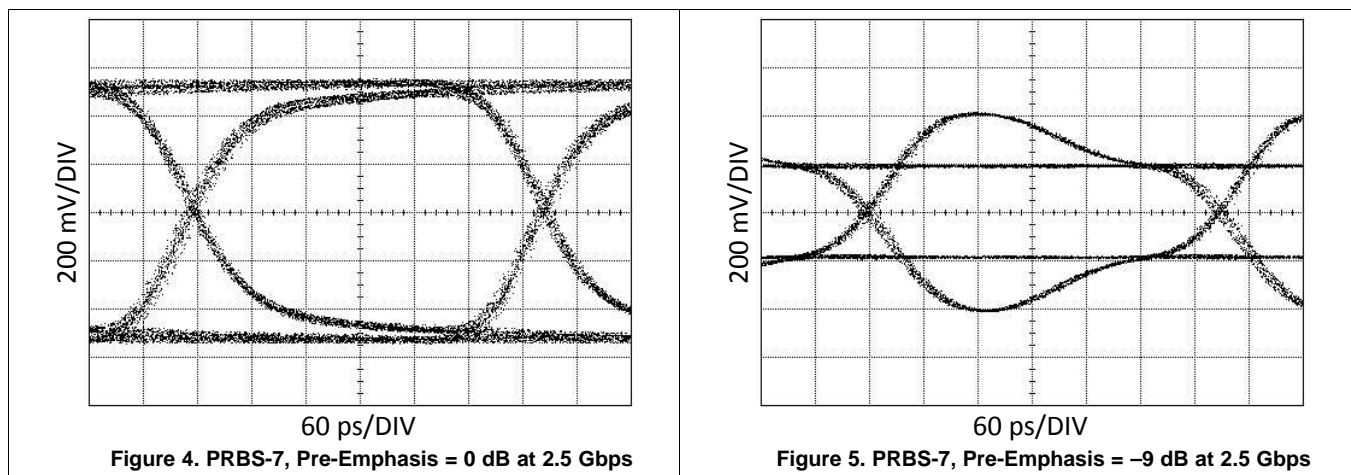

Figure 4. PRBS-7, Pre-Emphasis = 0 dB at 2.5 Gbps

Figure 5. PRBS-7, Pre-Emphasis = -9 dB at 2.5 Gbps

### 7 Parameter Measurement Information

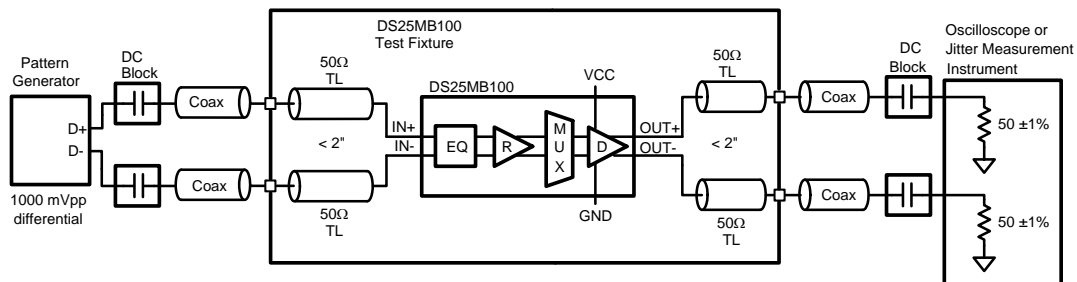

Figure 6. AC Test Circuit

## 8 Detailed Description

### 8.1 Overview

The DS25MB100 is a signal-conditioning 2:1 multiplexer and a 1:2 buffer designed to support port redundancy with encoded or scrambled data rates up to 2.5 Gbps. The DS25MB100 is not designed to operate with data rates below 250 Mbps or with a DC bias applied to the CML inputs or outputs.

### 8.2 Functional Block Diagram

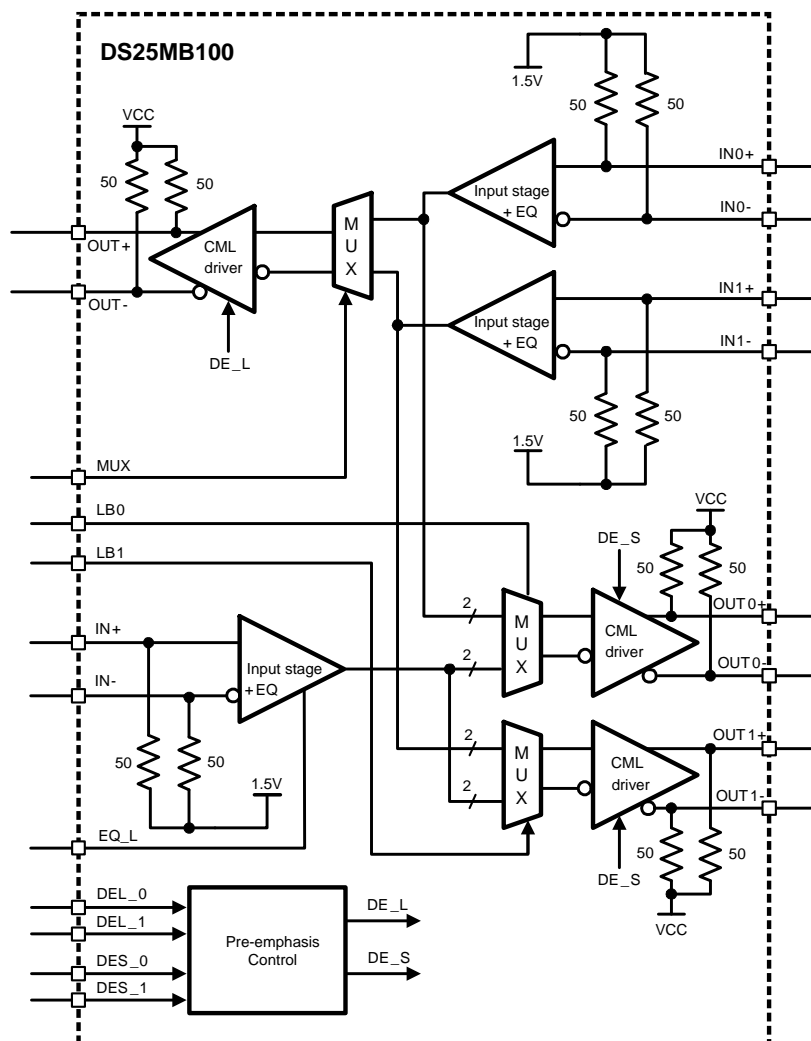

Figure 7. Simplified Block Diagram

### 8.3 Feature Description

The DS25MB100 MUX buffer consists of several key blocks:

- CML Inputs and EQ
- Multiplexer and Loopback Control
- CML Drivers and Pre-Emphasis Control

## Feature Description (continued)

### 8.3.1 CML Inputs and EQ

The high speed inputs are self-biased to about 1.3 V at IN+ and IN– and are designed for AC coupling, allowing the DS25MB100 to be inserted directly into the datapath without any limitation. See [Figure 8](#) for details about the internal receiver input termination and bias circuit.

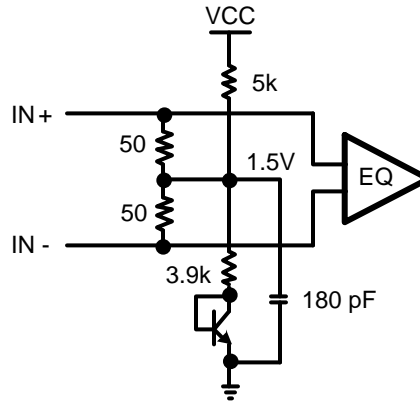

**Figure 8. Receiver Input Termination and Bias Circuit**

The inputs are compatible to most AC-coupling differential signals such as LVDS, LVPECL, and CML. The ideal AC-coupling capacitor value is often based on the lowest frequency component embedded within the serial link. A typical AC-coupling capacitor value ranges from 100 to 1000 nF. Some specifications with scrambled data may require a larger coupling capacitor for optimal performance. To reduce unwanted parasitics around and within the AC-coupling capacitor, TI recommends a body size of 0402. [Figure 6](#) shows the AC-coupling capacitor placement in an AC test circuit.

Each input stage has a fixed equalizer that provides equalization to compensate about 5 dB (at 1.25 GHz) of transmission loss from a short backplane trace (about 10 inches backplane). EQ can be enabled or disabled with the EQL and EQS pins.

**Table 1. EQ Controls for Line and Switch Inputs**

PIN	PIN VALUE	EQUALIZER FUNCTION
EQL, EQS	0	Enable equalization.
	1 (default)	Normal mode. Equalization disabled.

### 8.3.2 Multiplexer and Loopback Control

[Table 2](#) and [Table 3](#) provide details about how to configure the DS25MB100 multiplexer and loopback settings.

**Table 2. Logic Table for Multiplex Controls**

PIN	PIN VALUE	MUX FUNCTION
MUX	0	MUX select switch input IN1±.
	1 (default)	MUX select switch input IN0±.

**Table 3. Logic Table for Loopback Controls**

PIN	PIN VALUE	LOOPBACK FUNCTION
LB0	0	Enable loopback from IN0± to OUT0±.
	1 (default)	Normal mode. Loopback disabled.
LB1	0	Enable loopback from IN1± to OUT1±.
	1 (default)	Normal mode. Loopback disabled.

### 8.3.3 CML Drivers and Pre-Emphasis Control

The output driver has pre-emphasis (driver-side equalization) to compensate the transmission loss of the backplane that it is driving. The driver conditions the output signal such that the lower frequency and higher frequency pulses reach approximately the same amplitude at the end of the backplane and minimize the deterministic jitter caused by the amplitude disparity. The DS25MB100 provides four steps of user-selectable pre-emphasis ranging from 0, -3, -6 and -9 dB to handle different lengths of backplane. Figure 9 shows a driver pre-emphasis waveform. The pre-emphasis duration is 188 ps nominal, corresponding to 0.47 unit intervals (UI) at 2.5 Gbps. The pre-emphasis levels of switch-side and line-side can be individually programmed.

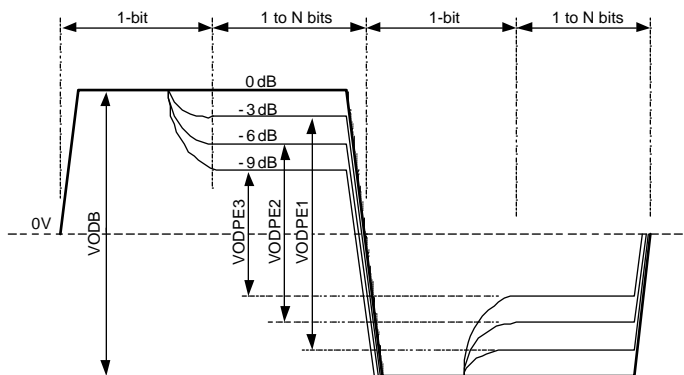

Figure 9. Driver Pre-Emphasis Differential Waveform (Showing All 4 Pre-Emphasis Steps)

Table 4. Line-Side Pre-Emphasis Controls

DEL_[1:0]	PRE-EMPHASIS LEVEL IN mV <sub>PP</sub> (VODB)	PRE-EMPHASIS LEVEL IN mV <sub>PP</sub> (VODPE)	PRE-EMPHASIS IN dB (VODPE/VODB)	TYPICAL FR4 BOARD TRACE
0 0	1300	1300	0	10 inches
0 1	1300	920	-3	20 inches
1 0	1300	650	-6	30 inches
1 1 (default)	1300	461	-9	40 inches

Table 5. Switch-Side Pre-Emphasis Controls

DES_[1:0]	PRE-EMPHASIS LEVEL IN mV <sub>PP</sub> (VODB)	PRE-EMPHASIS LEVEL IN mV <sub>PP</sub> (VODPE)	PRE-EMPHASIS IN dB (VODPE/VODB)	TYPICAL FR4 BOARD TRACE
0 0	1300	1300	0	10 inches
0 1	1300	920	-3	20 inches
1 0	1300	650	-6	30 inches
1 1 (default)	1300	461	-9	40 inches

## 9 Application and Implementation

### NOTE

Information in the following applications sections is not part of the TI component specification, and TI does not warrant its accuracy or completeness. TI's customers are responsible for determining suitability of components for their purposes. Customers should validate and test their design implementation to confirm system functionality.

### 9.1 Application Information

The DS25MB100 is a 2:1 MUX and 1:2 buffer that equalizes input data up to 2.5 Gbps and provides transmit pre-emphasis controls to improve overall signal reach. As a MUX buffer, the DS25MB100 is ideal for designs where there is a need for port sharing or redundancy as well as on-the-fly reorganization of routes and data connections.

### 9.2 Typical Application

A typical application for the DS25MB100 is shown in [Figure 10](#) and [Figure 11](#).

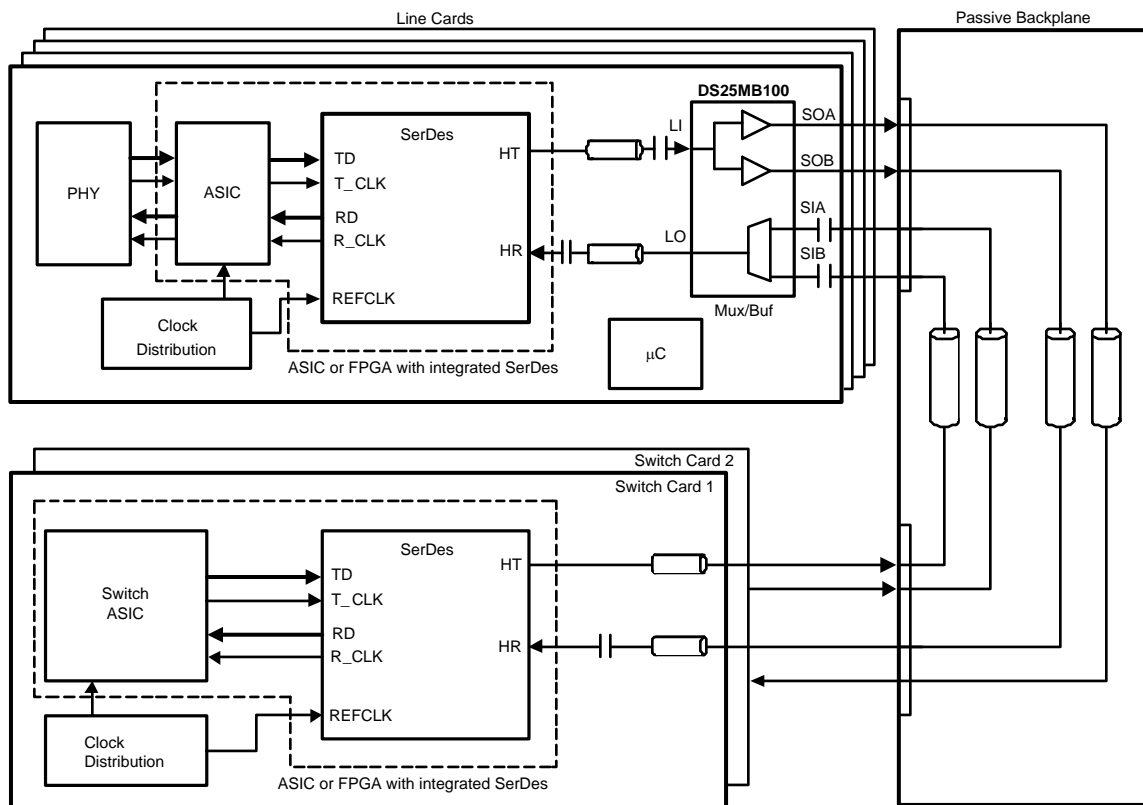

**Figure 10. Network Switch System With Redundancy**

Typical Application (continued)

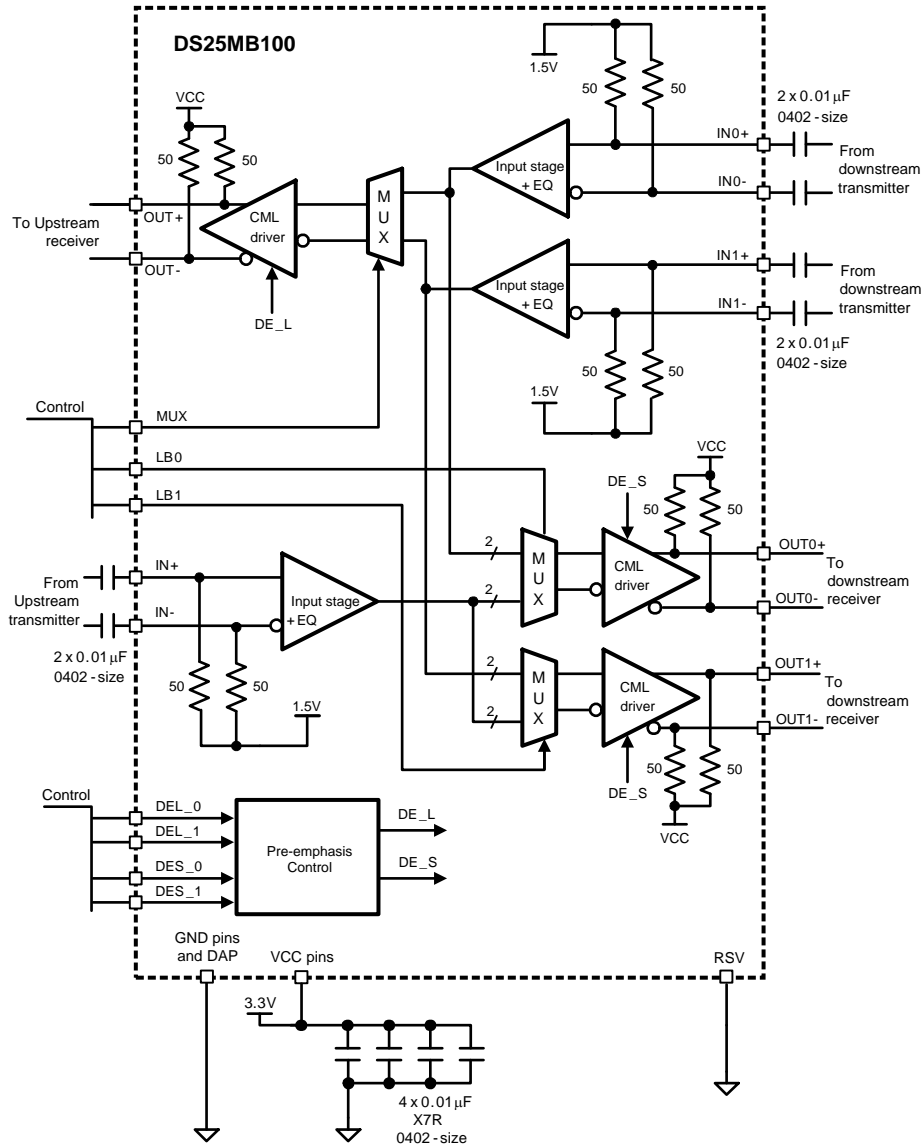

Figure 11. DS25MB100 Connection Block Diagram

9.2.1 Design Requirements

In a typical design, the DS25MB100 equalizes a short backplane trace on its input, followed by a longer trace at the DS25MB100 output. In this application example, a 25-inch FR4 coupled micro-strip board trace is used in place of the short backplane link. See Figure 12 for a block diagram of this example.

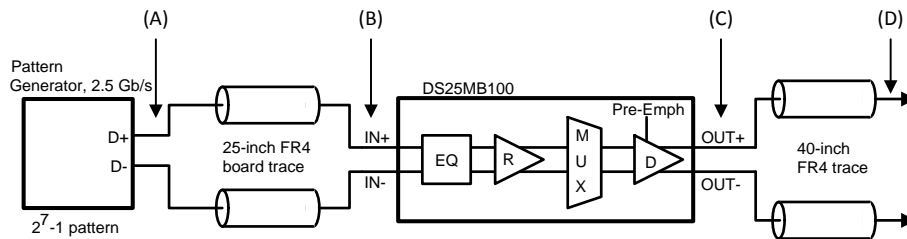

Figure 12. Block Diagram of DS25MB100 Application Example

## Typical Application (continued)

The 25-inch microstrip board trace has approximately 6 dB of attenuation at 1.875 GHz, representing closely the transmission loss of the short backplane transmission line. The 25-inch microstrip is connected between the pattern generator and the differential inputs of the DS25MB100 for AC measurements.

**Table 6. Input Trace Parameters**

TRACE LENGTH	FINISHED TRACE WIDTH W	SEPARATION BETWEEN TRACES	DIELECTRIC HEIGHT H	DIELECTRIC CONSTANT $\epsilon_R$	LOSS TANGENT
25 inches	8.5 mil	11.5 mil	6 mil	3.8	0.022

The length of the output trace may vary based on system requirements. In this example, a 40-inch FR4 trace with similar trace width, separation, and dielectric characteristics, is placed at the DS25MB100 output.

As with any high speed design, there are many factors which influence the overall performance. The following is a list of critical areas for consideration and study during design.

- Use 100- $\Omega$  impedance traces. Generally these are very loosely coupled to ease routing length differences.
- Place AC-coupling capacitors near to the receiver end of each channel segment to minimize reflections.
- The maximum body size for AC-coupling capacitors is 0402.
- Back-drill connector vias and signal vias to minimize stub length.
- Use reference plane vias to ensure a low inductance path for the return current.

### 9.2.2 Detailed Design Procedure

For optimal design, the DS25MB100 must be configured to route incoming data correctly as well as provide the best signal quality. The following design procedures should be observed:

1. The DS25MB100 must be configured to provide the correct MUX and buffer routes in order to satisfy system requirements. In order to set the appropriate MUX control settings, refer to [Table 2](#). To configure the buffer control settings, refer to [Table 3](#). For example, consider the case where the designer wishes to route the input from Switch Card 0 (IN0 $\pm$ ) to the output for the line card (OUT $\pm$ ). To accomplish this, set MUX = 1 (select IN0 $\pm$ ). For the other direction from line card output to switch card, set LB0 = 1 and LB1 = 1 so that the input from the line card is buffered to both Switch Card 0 (OUT0 $\pm$ ) and Switch Card 1 (OUT1 $\pm$ ).
2. The DS25MB100 is designed to be placed at an offset location with respect to the overall channel attenuation. To optimize performance, determine whether input and output equalization is required. Set EQL = 0 and EQS = 0 to enable input equalization. The MUX buffer transmit pre-emphasis can be tuned to extend the trace length reach while also recovering a solid eye opening. To tune transmit pre-emphasis on either the line card side or switch card side, refer to [Table 4](#) and [Table 5](#) for recommended pre-emphasis control settings according to the length of FR4 board trace connected at the DS25MB100 output. For example, if 40 inches of FR4 trace is connected to the switch card output, set DES\_[1:0] = (1, 1) for VOD = 1200 mVpp and –9 dB of transmit pre-emphasis.

### 9.2.3 Application Curves

[Figure 13](#) through [Figure 18](#) show how the signal integrity varies at different places in the data path. These measured locations can be referenced back to the labeled points provided in [Figure 12](#).

- Point (A): Output signal of source pattern generator
- Point (B): Input to DS25MB100 after 25 inches of FR4 trace from source
- Point (C): Output of DS25MB100 driver
- Point (D): Signal after 40 inches of FR4 trace from DS25MB100 driver

The source signal is a PRBS-7 pattern at 2.5 Gbps. For the long output traces, the eye after 40 inches of output FR4 trace is significantly improved by adding –9 dB of pre-emphasis.

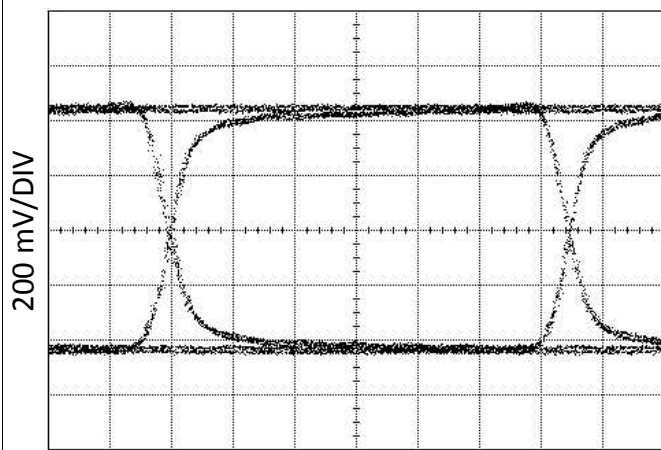

60 ps/DIV  
Figure 13. Eye Measured at Point (A)

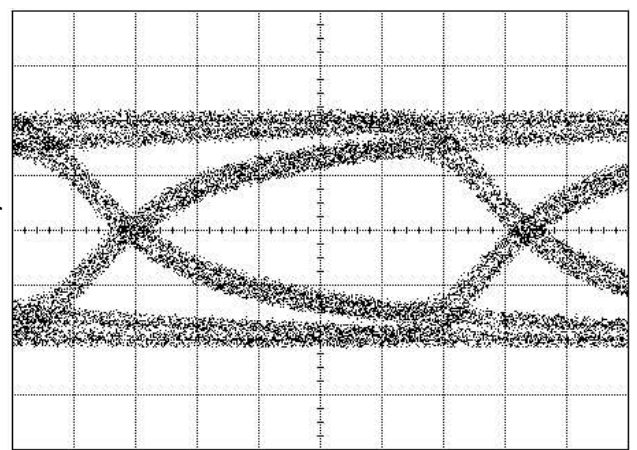

60 ps/DIV  
Figure 14. Eye Measured at Point (B)

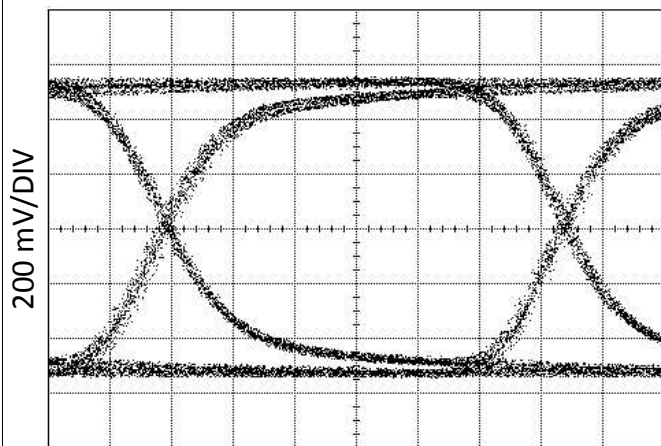

60 ps/DIV  
Figure 15. Eye Measured at Point (C),  
Pre-Emphasis = 0 dB

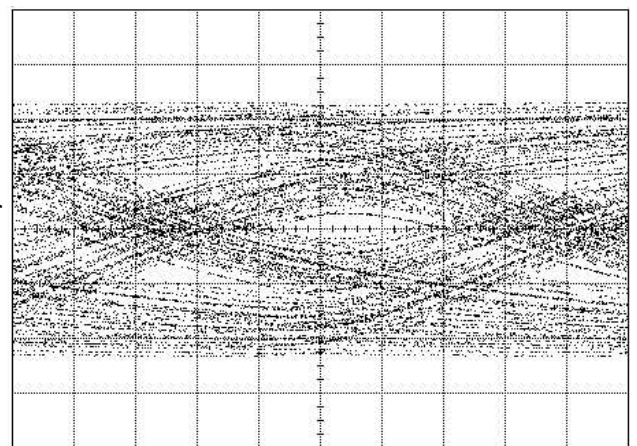

60 ps/DIV  
Figure 16. Eye Measured at Point (D),  
Pre-Emphasis = 0 dB

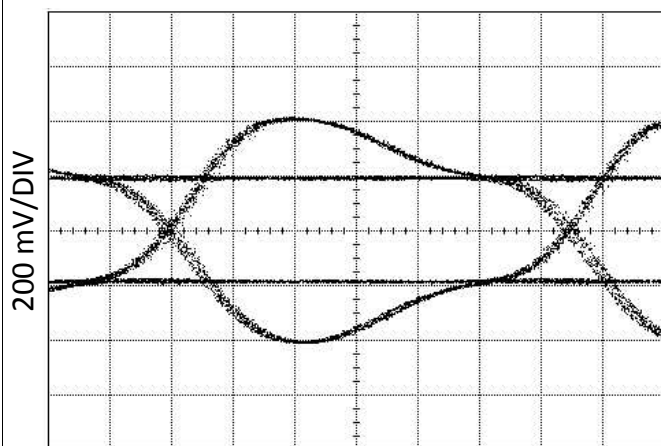

60 ps/DIV  
Figure 17. Eye Measured at Point (C),  
Pre-Emphasis = -9 dB

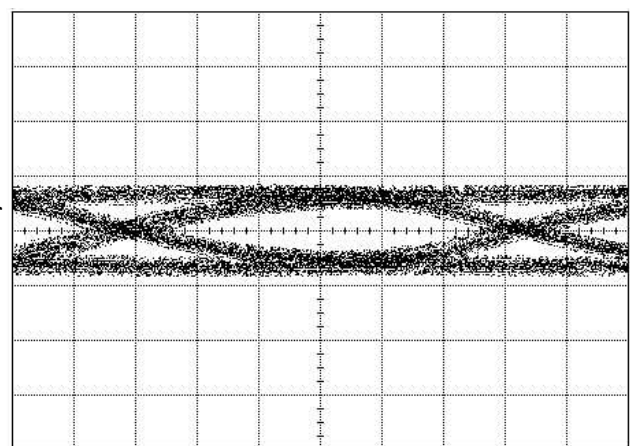

60 ps/DIV  
Figure 18. Eye Measured at Point (D),  
Pre-Emphasis = -9 dB

## 10 Power Supply Recommendations

The supply ( $V_{CC}$ ) and ground (GND) pins must be connected to power planes routed on adjacent layers of the printed-circuit board. The layer thickness of the dielectric must be minimized so that the  $V_{CC}$  and GND planes create a low inductance supply with distributed capacitance. Careful attention to supply bypassing through the proper use of bypass capacitors is required. A 0.01- $\mu$ F or 0.1- $\mu$ F bypass capacitor must be connected to each  $V_{CC}$  pin such that the capacitor is placed as close as possible to the  $V_{CC}$  pins. Smaller body size capacitors, such as 0402 body size, can help facilitate proper component placement. Refer to the  $V_{CC}$  pin connections in [Figure 11](#) for further details.

## 11 Layout

### 11.1 Layout Guidelines

Use at least a four layer board with a power and ground plane. Closely-coupled differential lines of 100  $\Omega$  are typically recommended for differential interconnect. The closely coupled lines help to ensure that coupled noise will appear as common-mode and thus will be rejected by the receivers. Information on the WQFN style package is provided in *AN-1187 Leadless Leadframe Package (LLP)*, [SNOA401](#).

Stencil parameters such as aperture area ratio and the fabrication process have a significant impact on paste deposition. Inspection of the stencil prior to placement of the WQFN package is highly recommended to improve board assembly yields. If the via and aperture openings are not carefully monitored, the solder may flow unevenly through the DAP. Stencil parameters for aperture opening and via locations are shown in [Figure 19](#). A layout example for the DS25MB100 is shown in [Figure 20](#), where 16 stencil openings are used for the DAP alongside nine vias to GND.

### 11.2 Layout Example

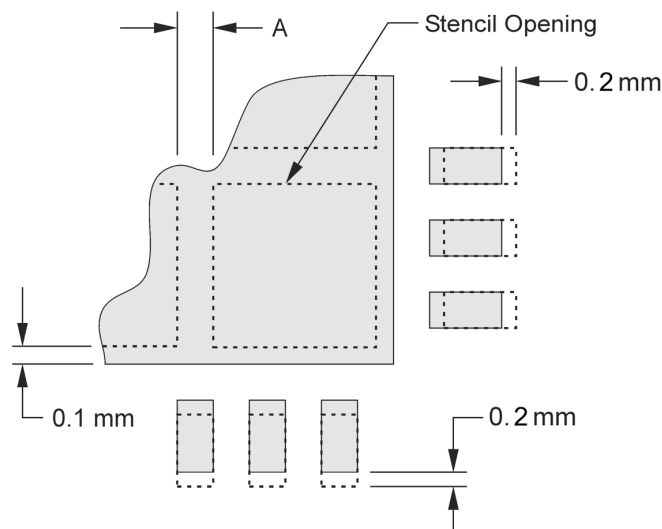

Figure 19. No Pullback WQFN, Single Row Reference Diagram

Table 7. No Pullback WQFN Stencil Aperture Summary for DS25MB100

DEVICE	PIN COUNT	MKT DWG	PCB I/O PAD SIZE (mm)	PCB PITCH (mm)	PCB DAP SIZE (mm)	STENCIL I/O APERTURE (mm)	STENCIL DAP APERTURE (mm)	NUMBER OF DAP APERTURE OPENINGS	GAP BETWEEN DAP APERTURE (Dim A mm)
DS25MB100	36	SQA36A	0.25 x 0.6	0.5	4.6 x 4.6	0.25 x 0.7	1.0 x 1.0	16	0.2

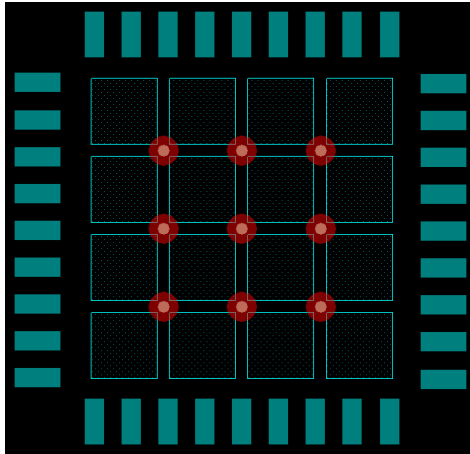

Figure 20. 36-Pin WQFN Stencil Example of Via and Opening Placement

## 12 Device and Documentation Support

### 12.1 Documentation Support

#### 12.1.1 Related Documentation

For related documentation, see the following:

*AN-1187 Leadless Leadframe Package (LLP)*, [SNOA401](#)

### 12.2 Community Resources

The following links connect to TI community resources. Linked contents are provided "AS IS" by the respective contributors. They do not constitute TI specifications and do not necessarily reflect TI's views; see TI's [Terms of Use](#).

**TI E2E™ Online Community** *TI's Engineer-to-Engineer (E2E) Community*. Created to foster collaboration among engineers. At [e2e.ti.com](#), you can ask questions, share knowledge, explore ideas and help solve problems with fellow engineers.

**Design Support** *TI's Design Support* Quickly find helpful E2E forums along with design support tools and contact information for technical support.

### 12.3 Trademarks

E2E is a trademark of Texas Instruments.  
All other trademarks are the property of their respective owners.

### 12.4 Electrostatic Discharge Caution



These devices have limited built-in ESD protection. The leads should be shorted together or the device placed in conductive foam during storage or handling to prevent electrostatic damage to the MOS gates.

### 12.5 Glossary

[SLYZ022](#) — *TI Glossary*.

This glossary lists and explains terms, acronyms, and definitions.

## 13 Mechanical, Packaging, and Orderable Information

The following pages include mechanical, packaging, and orderable information. This information is the most current data available for the designated devices. This data is subject to change without notice and revision of this document. For browser-based versions of this data sheet, refer to the left-hand navigation.

**PACKAGING INFORMATION**

Orderable Device	Status (1)	Package Type	Package Drawing	Pins	Package Qty	Eco Plan (2)	Lead/Ball Finish (6)	MSL Peak Temp (3)	Op Temp (°C)	Device Marking (4/5)	Samples
DS25MB100TSQ/NOPB	ACTIVE	WQFN	NJK	36	250	Green (RoHS & no Sb/Br)	CU SN	Level-3-260C-168 HR	-40 to 85	25MB100	<a href="#">Samples</a>
DS25MB100TSQX/NOPB	ACTIVE	WQFN	NJK	36	2500	Green (RoHS & no Sb/Br)	CU SN	Level-3-260C-168 HR	-40 to 85	25MB100	<a href="#">Samples</a>

(1) The marketing status values are defined as follows:

**ACTIVE:** Product device recommended for new designs.

**LIFEBUY:** TI has announced that the device will be discontinued, and a lifetime-buy period is in effect.

**NRND:** Not recommended for new designs. Device is in production to support existing customers, but TI does not recommend using this part in a new design.

**PREVIEW:** Device has been announced but is not in production. Samples may or may not be available.

**OBsolete:** TI has discontinued the production of the device.

(2) Eco Plan - The planned eco-friendly classification: Pb-Free (RoHS), Pb-Free (RoHS Exempt), or Green (RoHS & no Sb/Br) - please check <http://www.ti.com/productcontent> for the latest availability information and additional product content details.

**TBD:** The Pb-Free/Green conversion plan has not been defined.

**Pb-Free (RoHS):** TI's terms "Lead-Free" or "Pb-Free" mean semiconductor products that are compatible with the current RoHS requirements for all 6 substances, including the requirement that lead not exceed 0.1% by weight in homogeneous materials. Where designed to be soldered at high temperatures, TI Pb-Free products are suitable for use in specified lead-free processes.

**Pb-Free (RoHS Exempt):** This component has a RoHS exemption for either 1) lead-based flip-chip solder bumps used between the die and package, or 2) lead-based die adhesive used between the die and leadframe. The component is otherwise considered Pb-Free (RoHS compatible) as defined above.

**Green (RoHS & no Sb/Br):** TI defines "Green" to mean Pb-Free (RoHS compatible), and free of Bromine (Br) and Antimony (Sb) based flame retardants (Br or Sb do not exceed 0.1% by weight in homogeneous material)

(3) MSL, Peak Temp. - The Moisture Sensitivity Level rating according to the JEDEC industry standard classifications, and peak solder temperature.

(4) There may be additional marking, which relates to the logo, the lot trace code information, or the environmental category on the device.

(5) Multiple Device Markings will be inside parentheses. Only one Device Marking contained in parentheses and separated by a "~" will appear on a device. If a line is indented then it is a continuation of the previous line and the two combined represent the entire Device Marking for that device.

(6) Lead/Ball Finish - Orderable Devices may have multiple material finish options. Finish options are separated by a vertical ruled line. Lead/Ball Finish values may wrap to two lines if the finish value exceeds the maximum column width.

**Important Information and Disclaimer:** The information provided on this page represents TI's knowledge and belief as of the date that it is provided. TI bases its knowledge and belief on information provided by third parties, and makes no representation or warranty as to the accuracy of such information. Efforts are underway to better integrate information from third parties. TI has taken and continues to take reasonable steps to provide representative and accurate information but may not have conducted destructive testing or chemical analysis on incoming materials and chemicals. TI and TI suppliers consider certain information to be proprietary, and thus CAS numbers and other limited information may not be available for release.

In no event shall TI's liability arising out of such information exceed the total purchase price of the TI part(s) at issue in this document sold by TI to Customer on an annual basis.

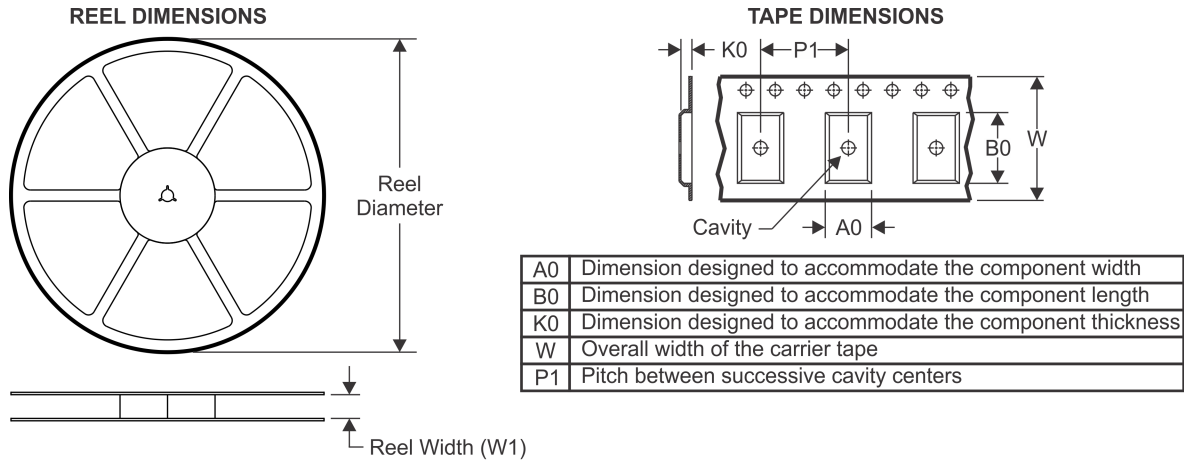
**TAPE AND REEL INFORMATION**

**QUADRANT ASSIGNMENTS FOR PIN 1 ORIENTATION IN TAPE**

\*All dimensions are nominal

Device	Package Type	Package Drawing	Pins	SPQ	Reel Diameter (mm)	Reel Width W1 (mm)	A0 (mm)	B0 (mm)	K0 (mm)	P1 (mm)	W (mm)	Pin1 Quadrant
DS25MB100TSQ/NOPB	WQFN	NJK	36	250	178.0	16.4	6.3	6.3	1.5	12.0	16.0	Q1
DS25MB100TSQX/NOPB	WQFN	NJK	36	2500	330.0	16.4	6.3	6.3	1.5	12.0	16.0	Q1

**TAPE AND REEL BOX DIMENSIONS**

\*All dimensions are nominal

Device	Package Type	Package Drawing	Pins	SPQ	Length (mm)	Width (mm)	Height (mm)
DS25MB100TSQ/NOPB	WQFN	NJK	36	250	210.0	185.0	35.0
DS25MB100TSQX/NOPB	WQFN	NJK	36	2500	367.0	367.0	38.0

## IMPORTANT NOTICE

Texas Instruments Incorporated and its subsidiaries (TI) reserve the right to make corrections, enhancements, improvements and other changes to its semiconductor products and services per JESD46, latest issue, and to discontinue any product or service per JESD48, latest issue. Buyers should obtain the latest relevant information before placing orders and should verify that such information is current and complete. All semiconductor products (also referred to herein as "components") are sold subject to TI's terms and conditions of sale supplied at the time of order acknowledgment.

TI warrants performance of its components to the specifications applicable at the time of sale, in accordance with the warranty in TI's terms and conditions of sale of semiconductor products. Testing and other quality control techniques are used to the extent TI deems necessary to support this warranty. Except where mandated by applicable law, testing of all parameters of each component is not necessarily performed.

TI assumes no liability for applications assistance or the design of Buyers' products. Buyers are responsible for their products and applications using TI components. To minimize the risks associated with Buyers' products and applications, Buyers should provide adequate design and operating safeguards.

TI does not warrant or represent that any license, either express or implied, is granted under any patent right, copyright, mask work right, or other intellectual property right relating to any combination, machine, or process in which TI components or services are used. Information published by TI regarding third-party products or services does not constitute a license to use such products or services or a warranty or endorsement thereof. Use of such information may require a license from a third party under the patents or other intellectual property of the third party, or a license from TI under the patents or other intellectual property of TI.

Reproduction of significant portions of TI information in TI data books or data sheets is permissible only if reproduction is without alteration and is accompanied by all associated warranties, conditions, limitations, and notices. TI is not responsible or liable for such altered documentation. Information of third parties may be subject to additional restrictions.

Resale of TI components or services with statements different from or beyond the parameters stated by TI for that component or service voids all express and any implied warranties for the associated TI component or service and is an unfair and deceptive business practice. TI is not responsible or liable for any such statements.

Buyer acknowledges and agrees that it is solely responsible for compliance with all legal, regulatory and safety-related requirements concerning its products, and any use of TI components in its applications, notwithstanding any applications-related information or support that may be provided by TI. Buyer represents and agrees that it has all the necessary expertise to create and implement safeguards which anticipate dangerous consequences of failures, monitor failures and their consequences, lessen the likelihood of failures that might cause harm and take appropriate remedial actions. Buyer will fully indemnify TI and its representatives against any damages arising out of the use of any TI components in safety-critical applications.

In some cases, TI components may be promoted specifically to facilitate safety-related applications. With such components, TI's goal is to help enable customers to design and create their own end-product solutions that meet applicable functional safety standards and requirements. Nonetheless, such components are subject to these terms.

No TI components are authorized for use in FDA Class III (or similar life-critical medical equipment) unless authorized officers of the parties have executed a special agreement specifically governing such use.

Only those TI components which TI has specifically designated as military grade or "enhanced plastic" are designed and intended for use in military/aerospace applications or environments. Buyer acknowledges and agrees that any military or aerospace use of TI components which have **not** been so designated is solely at the Buyer's risk, and that Buyer is solely responsible for compliance with all legal and regulatory requirements in connection with such use.

TI has specifically designated certain components as meeting ISO/TS16949 requirements, mainly for automotive use. In any case of use of non-designated products, TI will not be responsible for any failure to meet ISO/TS16949.

### Products

Audio	<a href="http://www.ti.com/audio">www.ti.com/audio</a>
Amplifiers	<a href="http://amplifier.ti.com">amplifier.ti.com</a>
Data Converters	<a href="http://dataconverter.ti.com">dataconverter.ti.com</a>
DLP® Products	<a href="http://www.dlp.com">www.dlp.com</a>
DSP	<a href="http://dsp.ti.com">dsp.ti.com</a>
Clocks and Timers	<a href="http://www.ti.com/clocks">www.ti.com/clocks</a>
Interface	<a href="http://interface.ti.com">interface.ti.com</a>
Logic	<a href="http://logic.ti.com">logic.ti.com</a>
Power Mgmt	<a href="http://power.ti.com">power.ti.com</a>
Microcontrollers	<a href="http://microcontroller.ti.com">microcontroller.ti.com</a>
RFID	<a href="http://www.ti-rfid.com">www.ti-rfid.com</a>
OMAP Applications Processors	<a href="http://www.ti.com/omap">www.ti.com/omap</a>
Wireless Connectivity	<a href="http://www.ti.com/wirelessconnectivity">www.ti.com/wirelessconnectivity</a>

### Applications



Automotive and Transportation	<a href="http://www.ti.com/automotive">www.ti.com/automotive</a>
Communications and Telecom	<a href="http://www.ti.com/communications">www.ti.com/communications</a>
Computers and Peripherals	<a href="http://www.ti.com/computers">www.ti.com/computers</a>
Consumer Electronics	<a href="http://www.ti.com/consumer-apps">www.ti.com/consumer-apps</a>
Energy and Lighting	<a href="http://www.ti.com/energy">www.ti.com/energy</a>
Industrial	<a href="http://www.ti.com/industrial">www.ti.com/industrial</a>
Medical	<a href="http://www.ti.com/medical">www.ti.com/medical</a>
Security	<a href="http://www.ti.com/security">www.ti.com/security</a>
Space, Avionics and Defense	<a href="http://www.ti.com/space-avionics-defense">www.ti.com/space-avionics-defense</a>
Video and Imaging	<a href="http://www.ti.com/video">www.ti.com/video</a>

### TI E2E Community

[e2e.ti.com](http://e2e.ti.com)

## Looking for pricing, stock, or lifecycle information?

Click below to explore more details on WIN SOURCE:

-  [View DS25MB100TSQX/NOPB on WIN SOURCE](#)
-  [Texas Instruments](#) Information

## Optimize Your Supply Chain with WIN SOURCE Solutions

-  Global Sourcing Solution
-  Obsolete Management
-  Cost Control Management
-  Shortage Management
-  Alternative Solution
-  Excess Inventory Management