



**THE DATASHEET OF
A5303SLETR-T**



Photoelectric Smoke Detector with Interconnect, Timer, and Latching Alarm Indicator

Features and Benefits

- Low average standby current allows 10-year battery life
- 2.3 to 5.5 V operating range
- Interconnect option
- Logic outputs to control an external sound IC
- Low battery detection and warning
- Chamber sensitivity test and warning
- Triple horn-chirp to distinguish chamber warning
- Power-on reset (POR)
- Digital filter on I/O provides significant noise immunity
- Timer (hush) mode for enabling reduced sensitivity period
- Built-in circuits to reduce false triggering
- ESD protection circuitry on all pins
- Temporal Horn Pattern, per UL217, NFPA72, ISO8201
- Latching alarm indicator identifies alarm-initiating devices

Packages:

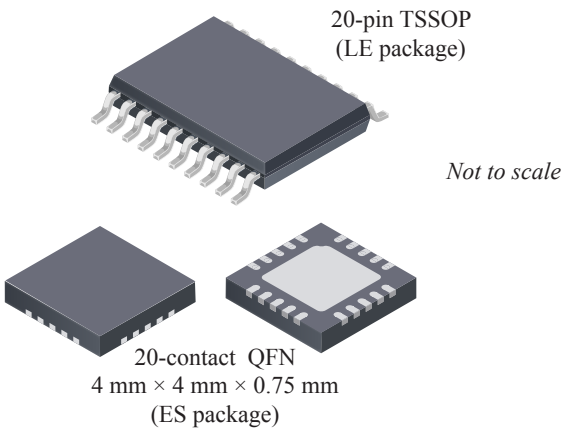

Description

The A5303 is a low-current BiCMOS photoelectric smoke detector circuit with ultra-low standby current and can operate for 10 years powered by inexpensive batteries. This device can be used with an infrared optical chamber to sense light scattered from smoke particles. A networking capability allows units to be interconnected so that if any unit senses smoke all units will sound an alarm. Special features are incorporated in the design to facilitate calibration and testing of the finished detector.

A variable-gain photoamplifier can be directly interfaced to an infrared emitter-detector pair. The amplifier gain levels are determined by two external capacitors and are internally selected depending on the operating mode. Low gain is selected during standby and timer modes. During a local alarm, this low gain is increased (internally) by approximately 45% to provide hysteresis. High gain is used during pushbutton test and to periodically monitor the chamber sensitivity during standby. The internal oscillator and timing circuitry minimize standby power by sensing for smoke for only 100 μ s once every 10 s. A special three-stage-speedup sensing scheme is incorporated to minimize the time to an audible alarm and also to reduce false triggering. Chamber sensitivity is periodically monitored and two consecutive cycles of degraded sensitivity are required for a warning signal to occur.

The A5303 is supplied in a thin profile (<1.2 mm overall height) 20-pin TSSOP (LE) package (0.65 mm nominal lead pitch) and a 20-contact QFN (ES) package with exposed thermal pad. Both packages are lead (Pb) free with 100% matte tin leadframe plating.

Typical Application Diagram

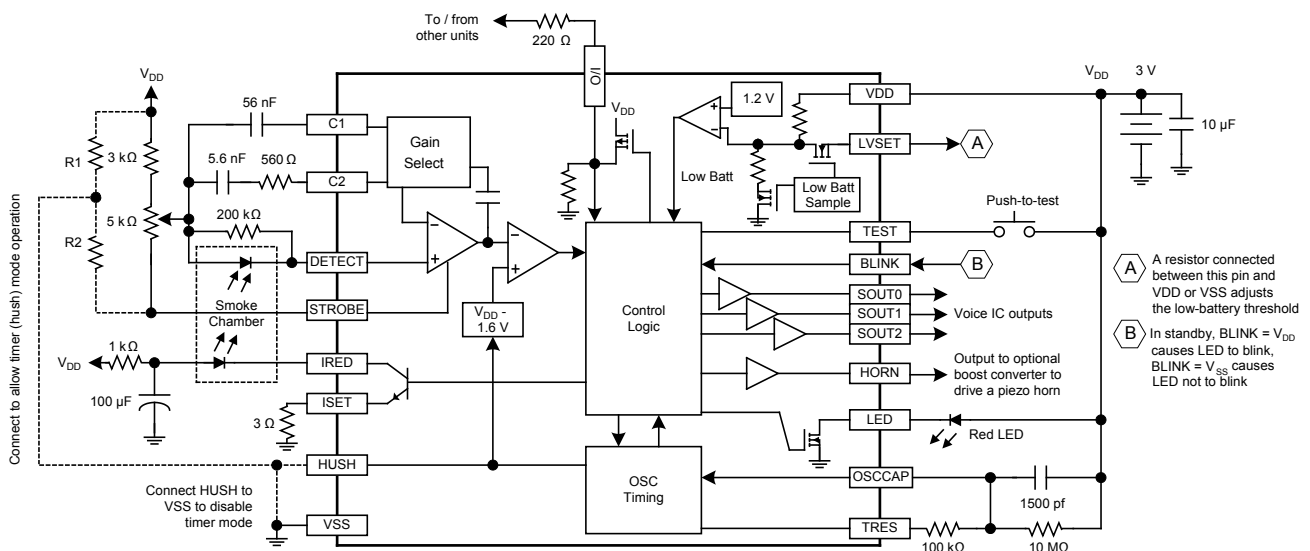

A5303

Photoelectric Smoke Detector with Interconnect, Timer, and Latching Alarm Indicator

Selection Guide

Part Number	Pb-free and RoHS	Package	Packing
A5303SESTR-T	Yes	20-contact QFN	1500 pieces / 7-in. reel
A5303SLE-T	Yes	20-pin TSSOP (JEDEC MO-153AC)	75 pieces / tube
A5303SLETR-T	Yes	20-pin TSSOP (JEDEC MO-153AC)	4000 pieces / reel

Absolute Maximum Ratings

Characteristic	Symbol	Notes	Rating	Units
Supply Voltage Range	V_{DD}	Referenced to V_{SS}	-2.3 to 6	V
DC Input Voltage Range	V_{IN}	Referenced to V_{SS}	-0.3 to 6	V
Operating Ambient Temperature Range	T_A	Allegro Range S	-20 to 85	°C
Maximum Junction Temperature	$T_{J(max)}$		150	°C
Storage Temperature Range	T_{stg}		-55 to 150	°C

Thermal Characteristics

Characteristic	Symbol	Test Conditions*	Value	Units
Package Thermal Resistance	$R_{\theta JA}$	ES Package, 4-layer PCB, based on JEDEC standard	37	°C/W
		LE Package, estimated, single-layer PCB, minimal exposed copper area	127	°C/W

*Additional thermal information available on Allegro website.

Pin-out Diagram

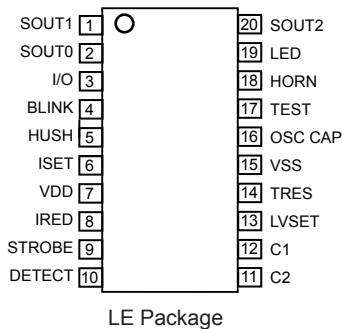
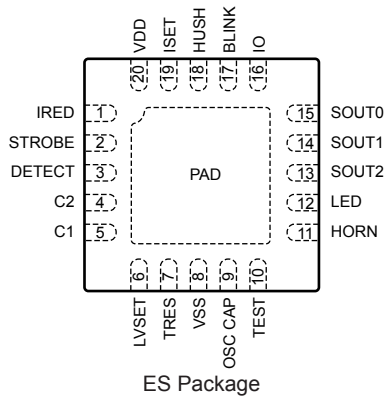

Terminal List

Number		Name	Function
ES	LE		
14	1	SOUT1	Logic push-pull output for controlling an external sound IC
15	2	SOUT0	Logic push-pull output for controlling an external sound IC
16	3	I/O	Input-output to interconnected detectors
17	4	BLINK	Logic input for enabling/disabling the LED blink during standby
18	5	HUSH	Input for photoamplifier timer mode reference; can also disable timer mode
19	6	ISET	A resistor on this pin connected to VSS sets the IRED output current
20	7	VDD	Positive supply voltage
1	8	IRED	Terminal to drive smoke chamber IR LED
2	9	STROBE	Strobed supply ($V_{DD} - 2V$) for photoamplifier low-side reference
3	10	DETECT	Photoamplifier input
4	11	C2	Sets photoamplifier gain in standby mode
5	12	C1	Sets photoamplifier gain in supervisory mode
6	13	LVSET	Optionally used with a resistor to adjust the low-battery threshold
7	14	TRES	Connection for resistor to set clock times/frequency
8	15	VSS	Negative supply voltage
9	16	OSC CAP	Connection for capacitor and resistor to set clock times/frequency
10	17	TEST	Enables push-to-test mode; starts timer mode, if enabled
11	18	HORN	Logic output which optionally enables a boost converter to drive a horn
12	19	LED	Output to drive visible LED
13	20	SOUT2	Logic push-pull output for controlling an external sound IC
PAD	-	-	Exposed pad for enhanced thermal dissipation

DC ELECTRICAL CHARACTERISTICS¹ Valid at $T_A = 25^\circ\text{C}$, $V_{DD} = 2.3$ to 5.5 V, configured as in Typical Application Diagram (unless otherwise noted)

Characteristics	Symbol	Test Conditions	Min.	Typ. ²	Max.	Unit
Supply Voltage Range	V_{DD}	Operating	2.3	3.0	5.5	V
Operating Supply Current	I_{DD}	During standby, STROBE off	–	2.3	5.0	μA
		During STROBE on, IRED off	–	210	300	μA
		During STROBE on, IRED on	–	220	300	μA
Input Current	I_{IN}	BLINK, C1, C2, DETECT, OSC CAP, TRES (pulldown off)	–100	0	100	nA
TEST Pulldown Current	$I_{IN(\text{TEST})}$	$V_{\text{TEST}} = V_{DD} = 3$ V	–	3.5	–	μA
Logic Voltage Low	$V_{I(L)}$		–	–	$V_{DD} \times 0.3$	V
Logic Voltage High	$V_{I(H)}$		$V_{DD} \times 0.7$	–	–	V
Strobe Output Voltage	V_{ST}	Inactive	–	V_{DD}	–	V
		Active, $I_O = 100$ to 500 μA	$V_{DD} - 2.1$	$V_{DD} - 2.0$	$V_{DD} - 1.9$	V
Line Regulation	$\Delta V_{ST(\Delta V_{DD})}$	Active, $V_{DD} = 2.3$ to 5.5 V	–	–60	–	dB
Strobe Temperature Coefficient	α_{ST}	V_{STROBE} , $V_{DD} = 2.3$ to 5.5 V	–	0.01	–	% / $^\circ\text{C}$
Maximum IRED Current Setting	$I_{\text{IRED}(\text{MAX})}$	Current is set by selection of resistor on ISET pin	–	–	300	mA
IRED Current	I_{IRED}	$R_{\text{ISET}} = 3$ Ω	89	100	111	mA
IRED Temperature Coefficient	α_{IRED}	I_{IRED} , $V_{DD} = 2.3$ to 5.5 V	–	0.40	–	% / $^\circ\text{C}$
LED Drive Current	I_{LED}	$V_{\text{LED}} = 0.5$ V	0.6	1.2	1.8	mA
Low-Battery Warning Threshold	$V_{DD(\text{th})}$	LVSET open	2.4	2.5	2.6	V
Low-Battery Warning Minimum	$V_{DD(\text{warn})}$	VDD voltage guaranteed to operate SOUTx pins	1.8			V
Common Mode Voltage	V_{IC}	Photoamplifier input	$V_{DD} - 1.0$	–	$V_{DD} - 0.3$	V
Smoke Comparator Reference Voltage	V_{REF}	Any alarm condition, except hush mode	–	$V_{DD} - 1.6$	–	V
I/O Input Impedance	$Z_{\text{I/O}(\text{in})}$	No alarm conditions	40	83	–	k Ω
I/O Output Impedance	$Z_{\text{I/O}(\text{out})}$	Local or test alarm	–	3.9	5.7	k Ω

¹Limits over the operating temperature range are based on characterization data. Characteristics are production tested at 25°C only.

²Typical values are at 25°C and are given for circuit design information only.

AC ELECTRICAL CHARACTERISTICS¹ Valid at $T_A = 25^\circ\text{C}$, $V_{DD} = 2.3$ to 5.5 V, configured as in Typical Application Diagram (unless otherwise noted)

Characteristics	Symbol	Test Conditions	OSC Count	Min.	Typ. ²	Max.	Unit
Oscillator Period	t_{osc}		1	9.4	10.5	11.5	ms
Smoke Check	t_{smoke}		2 ¹⁰	9.6	10.75	11.9	s
Low Battery Test	$t_{battery}$	No low-battery detected	2 ¹⁸	41.3	45.9	50.5	min
	$t_{battery2}$	Low-battery detected	2 ¹²	39	43	48	s
Degraded Chamber Test	$t_{chamber}$	No degraded chamber detected	2 ¹⁸	41.3	45.9	50.5	min
	$t_{chamber2}$	Degraded chamber detected	2 ¹²	39	43	48	s
LED Pulse Period	t_{led0}	No local or remote smoke, BLINK = VSS	–	–	No LED Pulses	–	–
	t_{led1}	No local or remote smoke, BLINK = VDD	2 ¹²	39	43	48	s
	t_{led3}	Local smoke	48	0.45	0.50	0.55	s
	t_{led4}	Remote smoke only	–	–	No LED Pulses	–	–
	t_{led6}	Pushbutton test, induced alarm	48	0.45	0.50	0.55	s
	t_{led7}	Timer mode, no alarm	2 ¹⁰	9.67	10.75	11.83	s
LED Pulse Width	$t_{w(led)}$		1	9.5	10.5	11.5	ms
LED Pulse Spacing	$t_{sp(led)}$	3 pulses, degraded chamber	2 ⁶	0.60	0.67	0.74	s
STROBE Pulse Period	t_{st1}	No local or remote smoke	2 ¹⁰	9.6	10.75	11.9	s
	t_{st2}	After 1 of 3 valid samples	192	1.8	2.0	2.2	s
	t_{st3}	After 2 of 3 valid samples and during local alarm	96	0.8	1.0	1.1	s
	t_{st4}	Remote smoke only	768	7.2	8.0	8.9	s
	t_{st5}	Chamber test, no local alarm	2 ¹⁸	41.3	45.9	50.5	min
	t_{st6}	Pushbutton test, induced alarm	24	225	252	278	ms
STROBE Pulse Width	$t_{w(st)}$		1	9.5	10.5	11.5	ms
IRED Pulse Period	t_{ired1}	No local or remote smoke	2 ¹⁰	9.6	10.75	11.9	s
	t_{ired2}	After 1 of 3 valid samples	192	1.8	2.0	2.2	s
	t_{ired3}	After 2 of 3 valid samples and during local alarm	96	0.8	1.0	1.1	s
	t_{ired4}	Remote smoke only	768	7.2	8.0	8.9	s
	t_{ired5}	Chamber test, no local alarm	2 ¹⁸	41.3	45.9	50.5	min
	t_{ired6}	Pushbutton test, induced alarm	24	225	252	278	ms
IRED Pulse Width	$t_{w(ired)}$		0.01	94	105	116	μs
I/O to Active Delay	$t_{d(io)}$	Local alarm	–	–	0	–	s
I/O Charge Dump Duration	t_{dump}	End of local alarm or test	96	0.9	1.0	1.1	s
Rising Edge on I/O to Alarm	$t_{r(io)}$	No local alarm	9 to 13	$9 \times t_{osc}$	94.5 – 137	$13 \times t_{osc}$	ms

Continued on the next page...

AC ELECTRICAL CHARACTERISTICS (continued)¹ Valid at $T_A = 25^\circ\text{C}$, $V_{DD} = 2.3$ to 5.5 V, configured as in Typical Application Diagram (unless otherwise noted)

Characteristics	Symbol	Test Conditions	OSC Count	Min.	Typ. ²	Max.	Unit
SOUTx Output Warning Period	t_{soutx}	Low supply or degraded chamber	2 ¹²	38.9	43	47.1	s
SOUTx Output Warning Pulse Width	$t_{\text{w(soutx)}}$	Low supply or degraded chamber	1	9.5	10.5	11.5	ms
Horn Warning Pulse Period	t_{horn}	Low battery or degraded chamber	2 ¹²	38.9	43	47.1	s
Horn Warning Pulse Width	$t_{\text{w(horn)}}$	Low battery or degraded chamber	1	9.5	10.5	11.5	ms
Horn Warning Pulse Spacing	$t_{\text{sp(horn)}}$	3 chirps, degraded chamber	2 ⁶	0.60	0.67	0.74	s
Horn On-Time	$t_{\text{on(horn)}}$	Local, remote, or test alarm	48	450	500	550	ms
Horn Off-Time	$t_{\text{off1(horn)}}$	Local, remote, or test alarm (see Timing Diagrams section)	48	450	500	550	ms
	$t_{\text{off2(horn)}}$	Local, remote, or test alarm (see Timing Diagrams section)	144	1350	1500	1650	ms
Timer Mode Duration	t_{timer}		57344	9.0	10.0	11.0	min
Failed Push-Test Indication on SOUTx	t_{FAIL}	After TEST input goes low	2 ¹¹ to 3072	2 ¹¹ × t_{osc}	21.5 – 32.3	3072 × t_{osc}	s

¹Limits over the operating temperature range are based on characterization data. Characteristics are production tested at 25°C only.

²Typical values are at 25°C and are given for circuit design information only.

Pin and Circuit Description (In Typical Application)

C1 Pin

A capacitor connected to this pin determines the gain of the photoamplifier, A_e , during the push-to-test mode and during the chamber monitor test. A typical capacitor value for this high-gain (supervisory) mode is 0.047 μF , but it should be selected based on the photochamber background reflections reaching the detector and the required level of sensitivity. $A_e = 1 + (C_1/12)$, where C_1 is in pF. A_e should not exceed 10,000 and thus C_1 should not exceed 0.1 μF . Coupling of other signals to the C1, C2, and DETECT inputs must be minimized.

C2 Pin

A capacitor connected to this pin determines the gain of the photoamplifier, A_e , during standby. A typical capacitor value for this low-gain mode is 4700 pF, but it should be selected based on a specific photochamber and the desired level of sensitivity to smoke. $A_e = 1 + (C_2/12)$, where C_2 is in pF. A_e should not exceed 10,000 and thus C_2 should not exceed 0.1 μF . This gain increases by a nominal 45% after a local alarm is detected (three consecutive detections). A resistor must be installed in series with the C2 capacitor.

DETECT Pin

This is the input to the photoamplifier and is connected to the cathode of the photodiode. The photodiode is operated at zero bias and should have low dark leakage current and low capacitance. A shunt resistor must be installed in parallel with the photodiode.

STROBE Pin

This output provides a strobed, regulated voltage of $V_{DD} - 2\text{ V}$. The minus side of all internal and external photoamplifier circuitry is referenced to this pin.

VDD Pin

This pin is connected to the positive supply potential, typically 3 V.

LVSET Pin

This pin allows the user to externally adjust the low-battery alarm threshold. To increase the threshold, a resistor can be connected between LVSET and VDD. To decrease the threshold, a resistor can be connected between LVSET and VSS.

IRED Pin

This output provides a pulsed drive current for the external IR emitter. To minimize noise impact, the IRED is not active when

the visible LED output is active.

ISET Pin

This pin allows the user to externally set the IRED current by connecting a resistor between it and VSS. The IRED current controls the amount of light generated by the IR LED in the chamber. The IRED current, in mA, can be approximated using the following equation:

$$I_{\text{IRED}} (\text{mA}) = 300 / R_{\text{ISET}} \quad (1)$$

The chosen resistor should set a maximum of 300 mA (typically a minimum of 1 Ω).

I/O Pin

A connection at this pin allows multiple smoke detectors to be interconnected. If any single unit detects smoke, its I/O pin is driven high, and all connected units will sound their associated alarm indicators. As an input, this pin is sampled every 4 clock cycles (nominally 43 ms) during standby, and two consecutive samples and one additional clock with I/O high are required before signaling an alarm. If the I/O line goes low at all during the 96.8 ms, the remote alarm is not enabled, providing significant immunity to I/O noise and other pulses on the I/O line which are shorter than 9 clock cycles. The LED is suppressed when an alarm is signaled from an interconnected unit, and any local-alarm condition causes this pin to be ignored as an input. An internal NMOS device acts as a charge dump to aid in applications involving a large (distributed) capacitance, and is activated at the end of a local or test alarm. This pin has an on-chip pull-down device and must be left unconnected if not used. In the application, there should be a series current-limiting resistor to other smoke alarms.

SOUT0, SOUT1, SOUT2 Pins

These pins provide push-pull CMOS logic outputs to control an external sound IC. The outputs indicate the state of the device as follows:

Condition	SOUT2	SOUT1	SOUT0
Standby	L	L	L
Local Alarm	L	L	H
Remote Alarm	L	H	L
Push-Test Passed	L	H	H
Push-Test Failed	H	L	L
Low-Battery	H	L	H
Degraded Chamber	H	H	L

HORN Pin

The HORN pin is a logic output provided to enable an optional, external boost converter that can drive a piezoelectric (piezo) horn. Using a boost converter to drive a piezo horn allows alarms to generate high SPL levels from low supply voltages. HORN will be driven high to enable the boost converter. The output of the boost converter will be connected to the piezo horn such that the horn will sound when the converter is enabled. If a boost converter and horn are not used, this pin should be left open.

BLINK Pin

This logic input determines the LED operation while the device is in standby. If BLINK is connected to VDD the device will blink once every approximately 43 s in standby. If BLINK is connected to VSS the device will not blink in standby. If a low-battery or degraded-chamber condition exists while the device is in standby, the LED will blink as described in the Alarm Indications section, regardless of the state of the BLINK pin. The BLINK pin has no effect when the device is in local, remote, or test alarm.

LED Pin

This open-drain NMOS output is used to directly drive a visible LED. The LED indicates detector status as follows (with component values as in the typical application, all times nominal):

Condition	Pulse Occurrence
Standby, BLINK = VDD	Every 43.0 s
Standby, BLINK = VSS	No LED pulses
Local Smoke	Every 0.5 s
Remote Alarm	No pulses
Test Mode	Every 0.5 s
Timer (Hush) Mode	Every 10.8 s

OSC CAP (Oscillator Capacitor) Pin

A capacitor between this pin and VDD, along with a parallel resistor, forms part of a two-terminal oscillator and sets the internal clock low time. With component values shown, this nominal time is 10.4 ms and essentially the oscillator period, which is also the STROBE pulse width. The internal clock low time can be calculated by:

$$T_{low} = 0.693 \times R_{OSCCAP} \times C_{OSCCAP} \quad (2)$$

TRES (Timing Resistor) Pin

A resistor between this pin and OSC CAP is part of the two-terminal oscillator and sets the internal clock high time, which is also the IRED pulse width. With component values shown, this time is

nominally 105 μ s. The internal clock high time can be calculated by:

$$T_{high} = 0.693 \times R_{TRES} \times C_{OSCCAP} \quad (3)$$

VSS Pin

This pin is connected to the negative supply potential (usually ground).

HUSH Pin

This input pin serves two purposes in standby mode. It serves to enable/disable entering the internal 10-minute (nominal) “hush” timer mode, and also as the reference for the smoke comparator during timer mode. Timer mode allows the user to temporarily hush alarms caused by nuisance smoke or steam (such as from cooking).

When the voltage on this pin is greater than approximately 50 mV, entering timer mode is enabled, and a high-to-low transition on the TEST pin resets and starts timer mode. If use of timer mode is not desired this pin must be connected to VSS, and timer mode is disabled.

During timer mode the smoke comparator reference is established externally by a resistive divider (R1 and R2) between VDD and STROBE. Also, during timer mode the photoamplifier gain, A_e , is internally reduced to about 55% that during the normal-gain mode. Thus, $A_e = 1 + (C_2 / 22)$, where C_2 is in pF. These two conditions allow the detector to operate with reduced sensitivity during timer mode. If the level of smoke increases such that the temporary alarm threshold is reached, a local alarm will sound. If the HUSH pin is connected directly to STROBE without using a resistor divider, then a local alarm will never occur during timer mode, regardless of the smoke level. When not in timer mode, the smoke comparator reference is set internally to approximately $V_{DD} - 1.6$ V.

The resistor dividers formed by the adjustable photoamp-divider and the HUSH divider ($R1 + R2$, if timer mode is used) should be chosen so that the load on STROBE does not exceed 500 μ A. Thus, the photoamp-divider (8 k Ω in the typical application) in parallel with the HUSH divider ($R1 + R2$) shall be no less than 4 k Ω .

TEST Pin

This pin has an internal pulldown device and is used to manually invoke push-to-test mode and timer mode. Push-to-test mode is initiated by a voltage greater than approximately $V_{DD} - 0.5$ V on this pin (usually the closure of a normally open push-button switch to VDD). After one oscillator cycle, the amplifier gain is

increased by internal selection of C1 so that background reflections in the smoke chamber can be used to simulate a smoke condition, and IRED pulses every 252 ms (nominal). After the third IRED pulse (three consecutive simulated smoke conditions), the successful test signals a continuous passing-test-alarm condition to the sound IC, outputs the temporal pattern to the piezo horn, and activates the I/O pin. When the pushbutton is released, the input returns to V_{SS} due to the internal pulldown. After one oscillator cycle, the amplifier gain returns to normal, and after three additional IRED pulses (less than one second), the device exits this mode and returns to standby. This high-to-low transition on TEST also resets and starts the 10-minute (nominal) “hush” timer mode, if the mode is enabled via the HUSH pin. The high-to-low transition also resets the latching alarm indicator, if it is latched.

If the chamber malfunctions or is too dirty, the push-test will fail to simulate a smoke condition, and after three failed STROBE pulses the device signals a continuous failing-test-alarm condition on the SOUTx pins. The piezo driver and the I/O pins are not enabled.

Diagnostic Test/Calibration mode is available to facilitate calibration and test of the IC and the assembled detector. It is initiated by pulling TEST below V_{SS} by continuously drawing 200 μ A from the pin for at least one clock cycle on OSC CAP. The current should not exceed 500 μ A and under these conditions,

TEST pin voltage will clamp at approximately 250 mV below V_{SS} . One option is to connect TEST to a -5 V supply through a 15 k Ω resistor. In this mode, certain device pins are reconfigured as described in table 1. The IRED pulse rate is increased to one pulse every OSC CAP cycle and the STROBE pin is always active. To exit this mode, the TEST pin should be floated, or returned to V_{SS} , for at least one OSC CAP cycle.

Latching Alarm Indicator

When multiple smoke detectors are networked through the I/O line, the latching alarm indicator allows the user to identify which detector(s) initiated an alarm. When a local alarm condition occurs, the initiating detector(s) will latch the event in memory. After the alarm condition has expired (the device stops signaling the alarm condition to the sound IC) the initiating detector(s) will output an additional 10 ms LED pulse every 43 seconds. If the BLINK pin is connected to VDD, the additional pulse will occur 0.67 seconds after the normal standby pulse. The user can clear the latched alarm condition by pressing and releasing the push-to-test button. If the user does not press the push-to-test button, the

latched alarm condition will cease after 24 hours to preserve battery life, and to prevent masking future latched alarm indications.

Alarm Indications

Alarm conditions include: local smoke detection, a remote alarm, low battery, and degraded chamber sensitivity. These are indicated by a combination of SOUTx output, piezo horn, and LED signals, which continue until the alarm condition is resolved. A local alarm always overrides a remote alarm and a push-test. Remote alarm always overrides a push-test. A local alarm, remote alarm, or a push-test will inhibit warning signals for low battery or degraded chamber.

During a local or a remote alarm condition, the device continuously signals an alarm condition on the SOUTx pins that indicates the type of the alarm. The piezo horn output is a continuous modulated tone (temporal horn pattern), nominally: 0.5 s on, 0.5 s off, 0.5 s on, 0.5 s off, 0.5 s on, and 1.5 s off. The visible LED also distinguishes a local alarm from a remote alarm. During a

Table 1. Alternate Pin Configuration During Diagnostic Test/Calibration Mode

Pin Name	Alternate Configuration
I/O	Disabled as an output. A logic high on this pin places the photoamplifier output on the BLINK pin. The amplifier output appears as pulses.
HUSH	If the I/O pin is high, this pin controls the amplifier gain capacitor. If this pin is low, normal gain is selected. If this pin is high, supervisory gain is selected. NOTE: If I/O is low, clocking this pin will cause the device to exit diagnostic/calibration mode and enter an Allegro-defined test mode.
BLINK	If the I/O pin is high, this pin is reconfigured as the photoamplifier output.
SOUT0	If the I/O pin is high and the HUSH pin is low (normal gain), taking this pin to a high logic level increases the amplifier gain by $\approx 45\%$ (hysteresis).
SOUT2	This pin is reconfigured as the smoke integrator output. Three consecutive smoke detections will cause this pin to go high and three consecutive no-smoke detections cause this pin to go low.
LED	This pin becomes a low-battery indicator. The open-drain NMOS output is normally off. If V_{DD} falls below the low-battery threshold, the output turns on.
OSC CAP	This pin may be driven by an external clock source. Driving this pin low and high drives the internal clock low and high. The external RC network may remain intact.

local alarm, the LED blinks every 0.5 s (nominally), but during a remote alarm, the LED is disabled and does not blink.

The degraded-chamber test occurs periodically (nominally every 45.9 min). During this test, the gain of the photoamplifier is switched to the high (supervisory) level, set by C1. The device expects that the photodiode will receive enough background reflections in the chamber to cause an alarm condition. If a faulty, dirty, or obstructed chamber prevents this during a test, the test period decreases to 43 s. After two consecutive failed tests, the device signals a degraded chamber condition to the sound IC. It also chirps the horn and pulses the LED three times every 43 seconds. The condition is resolved when the chamber is either

cleared or cleaned, and the test period then reverts to (nominally) 45.9 min.

The low-battery test also occurs periodically (also nominally every 45.9 min, but at a different time than the degraded-chamber test). During this test a resistive divider off VDD is compared to an internal band-gap reference. If V_{DD} is below the threshold, the device signals a low battery condition to the sound IC and the test period decreases to 43 s. It also chirps the horn and pulses the LED once every 43 seconds. The condition is resolved when the battery is replaced and the test period then reverts to (nominally) 45.9 min.

Timing Diagrams

(Not to Scale)

Standby Mode

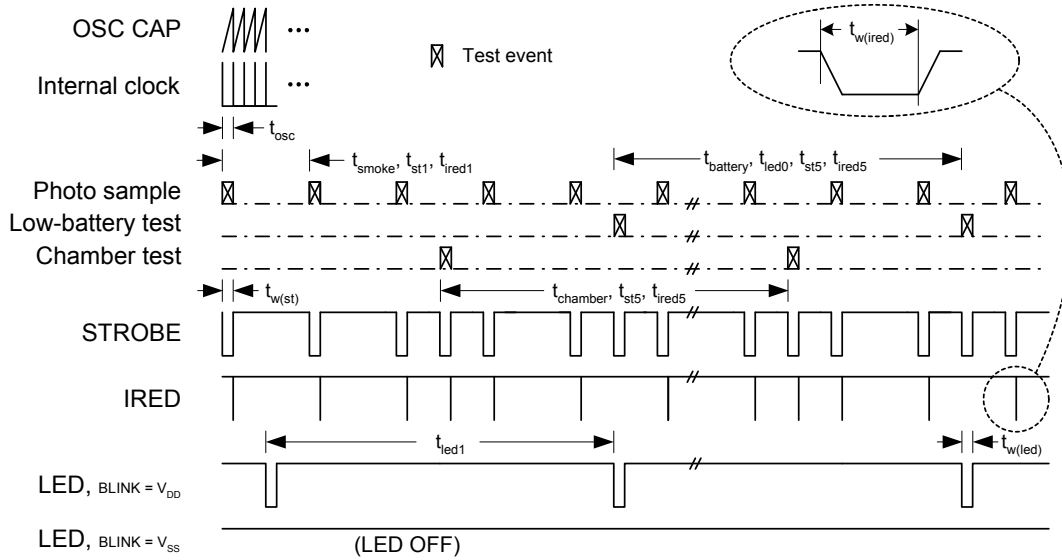

Low Battery Condition

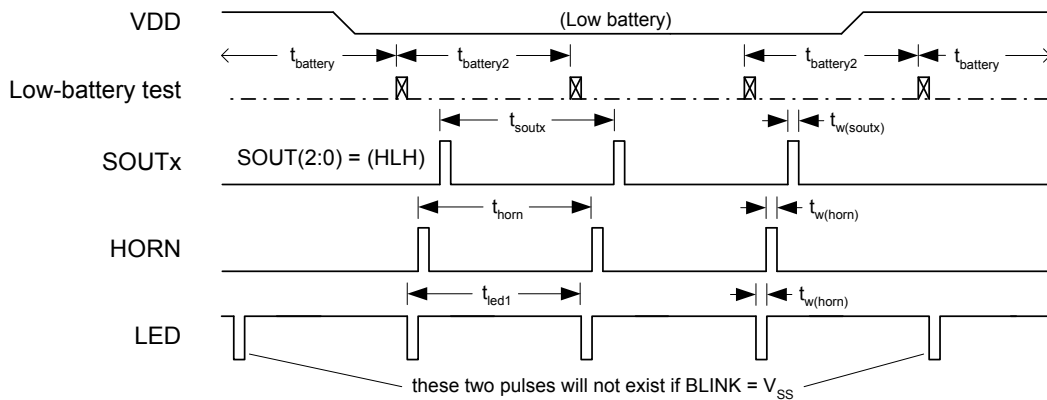

Degraded Chamber Condition

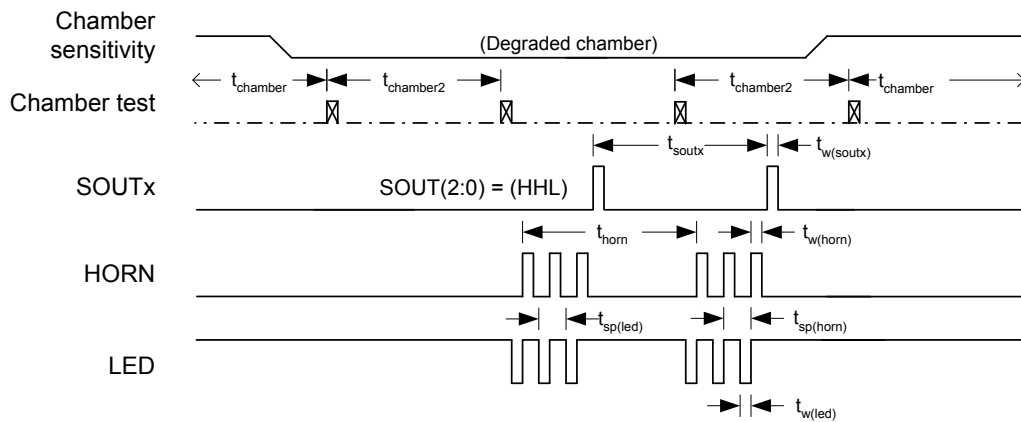

Local Smoke Detection Condition

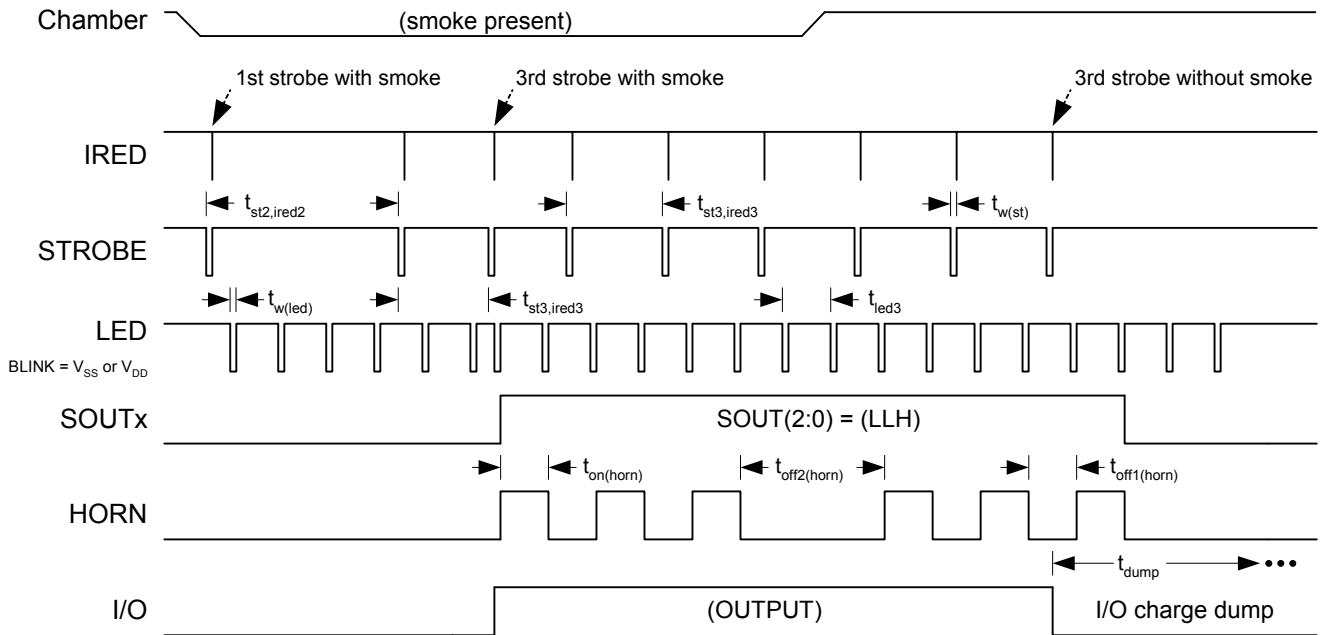

Remote Alarm Condition

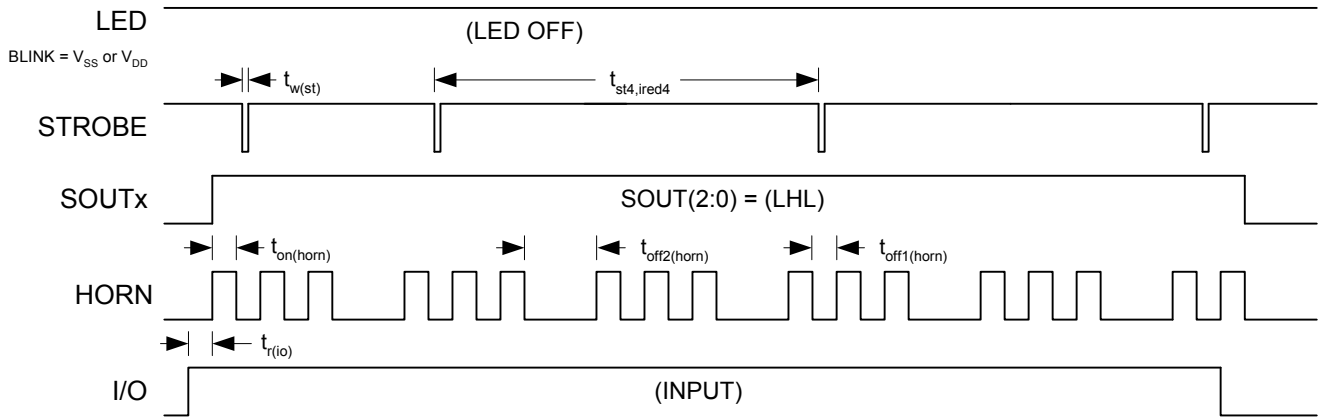

Test Alarm Mode (passing)

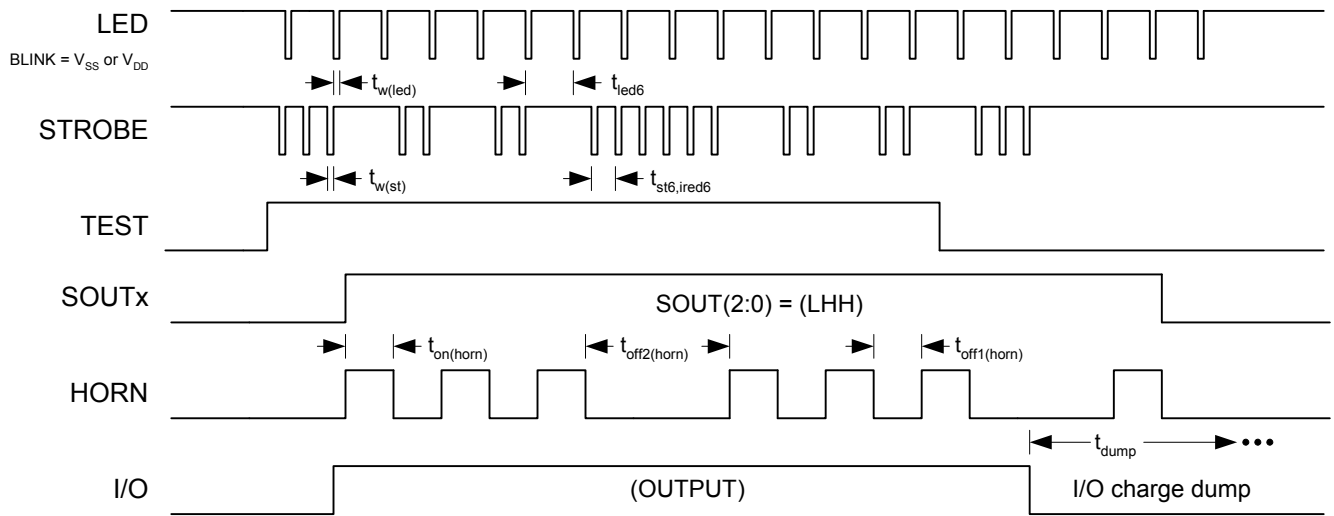

Test Alarm Mode (failing)

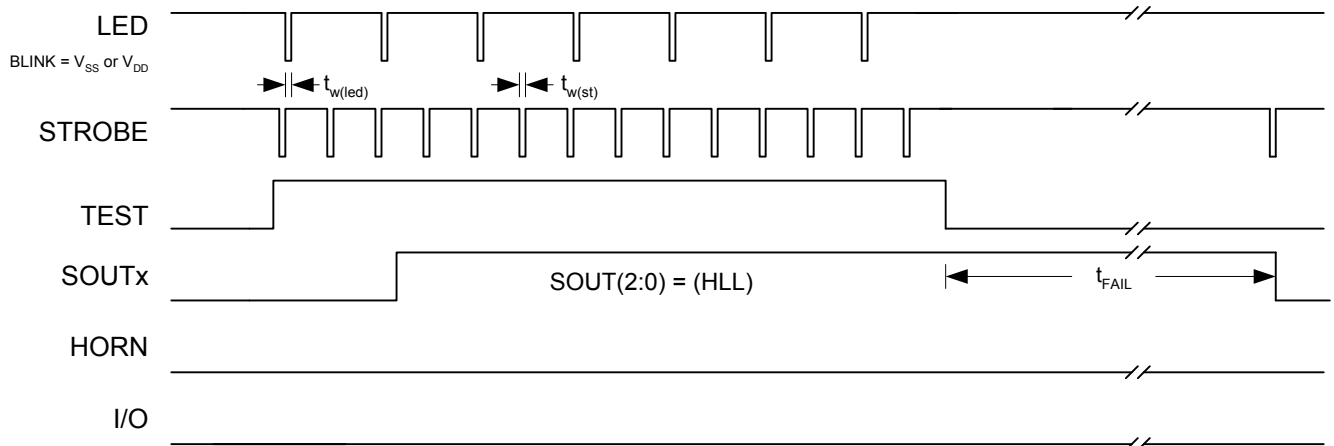

**Package ES, 20-Contact QFN
with Exposed Thermal Pad**

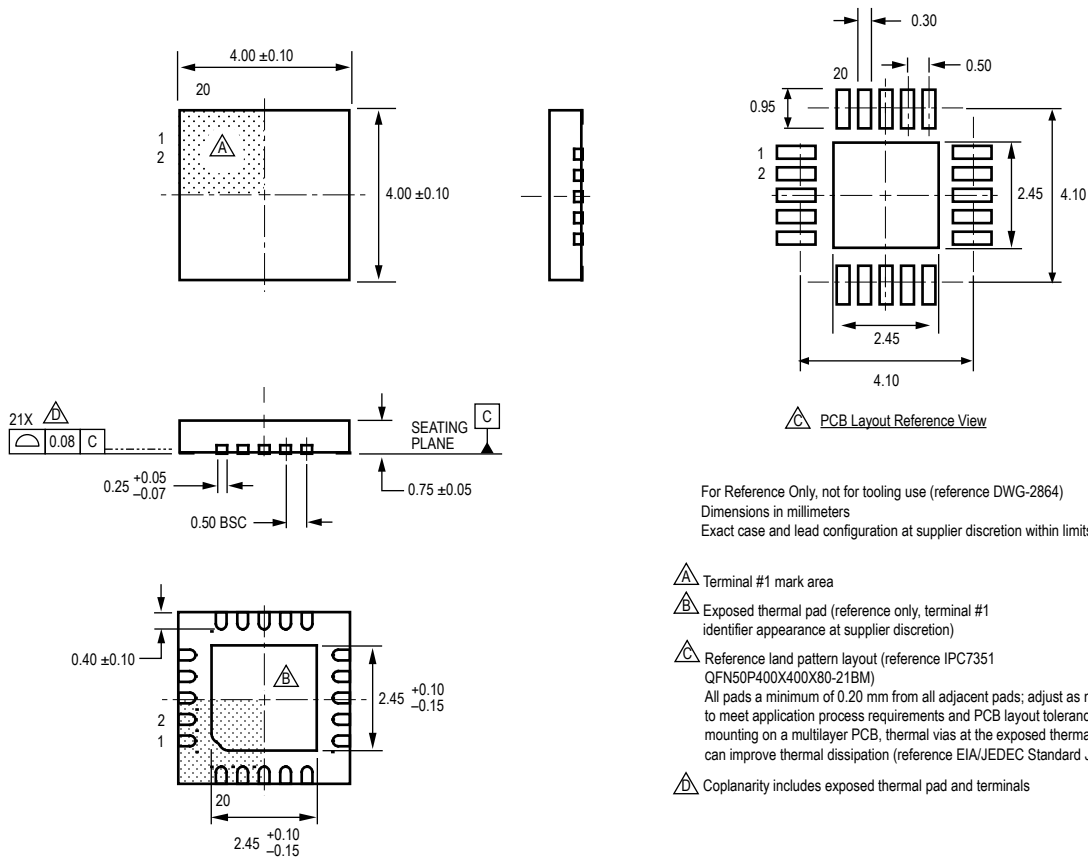

For Reference Only, not for tooling use (reference DWG-2864)
Dimensions in millimeters
Exact case and lead configuration at supplier discretion within limits shown

- △ Terminal #1 mark area
- △ Exposed thermal pad (reference only, terminal #1 identifier appearance at supplier discretion)
- △ Reference land pattern layout (reference IPC7351 QFN50P400X400X80-21BM)
All pads a minimum of 0.20 mm from all adjacent pads; adjust as necessary to meet application process requirements and PCB layout tolerances; when mounting on a multilayer PCB, thermal vias at the exposed thermal pad land can improve thermal dissipation (reference EIA/JEDEC Standard JESD51-5)
- △ Coplanarity includes exposed thermal pad and terminals

Package LE, 20-Pin TSSOP

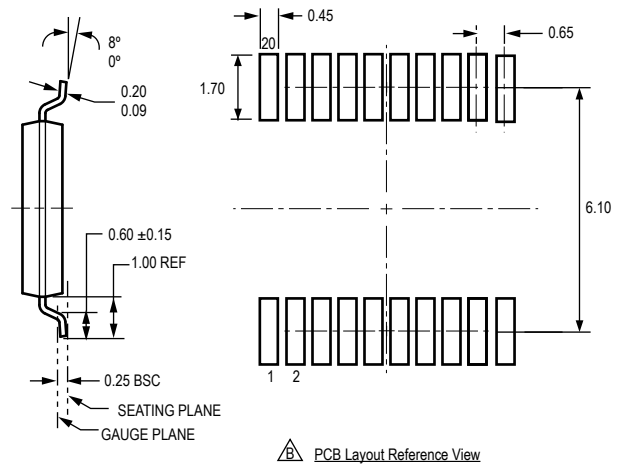
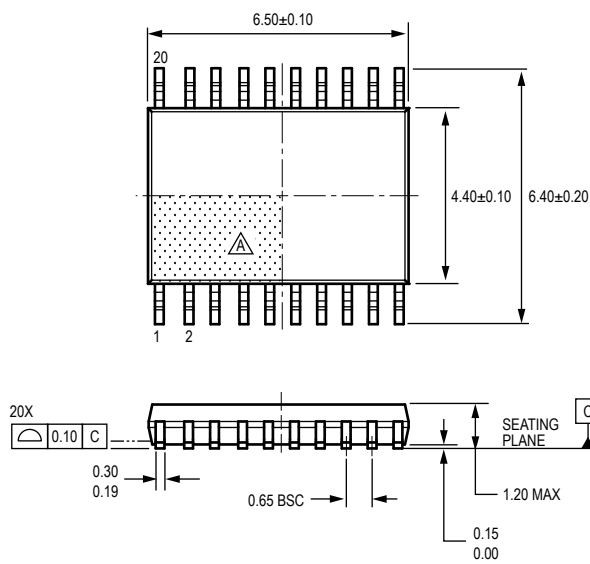

For Reference Only; not for tooling use (reference MO-153 AC)
 Dimensions in millimeters
 Dimensions exclusive of mold flash, gate burrs, and dambar protrusions
 Exact case and lead configuration at supplier discretion within limits shown

- △ Terminal #1 mark area
- △ Reference land pattern layout (reference IPC7351 SOP65P640X110-21M);
 All pads a minimum of 0.20 mm from all adjacent pads; adjust as necessary to meet application process requirements and PCB layout tolerances; when mounting on a multilayer PCB, thermal vias at the exposed thermal pad land can improve thermal dissipation (reference EIA/JEDEC Standard JESD51-5)

Revision History

Revision	Revision Date	Description of Revision
Rev. 1	November TBD, 2012	Add ES package

Allegro MicroSystems offers an industry-leading range of ionization and photoelectric smoke detector ICs. For a current listing, please visit our website at:

www.allegromicro.com

Copyright ©2001-2012, Allegro MicroSystems, Inc.

Allegro MicroSystems, Inc. reserves the right to make, from time to time, such departures from the detail specifications as may be required to permit improvements in the performance, reliability, or manufacturability of its products. Before placing an order, the user is cautioned to verify that the information being relied upon is current.

Allegro's products are not to be used in any devices or systems, including but not limited to life support devices or systems, in which a failure of Allegro's product can reasonably be expected to cause bodily harm.

The information included herein is believed to be accurate and reliable. However, Allegro MicroSystems, Inc. assumes no responsibility for its use; nor for any infringement of patents or other rights of third parties which may result from its use.

For the latest version of this document, visit our website:

www.allegromicro.com



Looking for pricing, stock, or lifecycle information?

Click below to explore more details on WIN SOURCE:

- ⊖ [View A5303SLETR-T on WIN SOURCE](#)
- ⊖ [Allegro MicroSystems, LLC Information](#)

Optimize Your Supply Chain with WIN SOURCE Solutions

- ✓ Global Sourcing Solution
- ✓ Obsolete Management
- ✓ Cost Control Management
- ✓ Shortage Management
- ✓ Alternative Solution
- ✓ Excess Inventory Management