



**THE DATASHEET OF
AD8418WBRZ**



FEATURES

Typical 0.1 $\mu\text{V}/^\circ\text{C}$ offset drift
Maximum $\pm 400 \mu\text{V}$ voltage offset over full temperature range
2.7 V to 5.5 V power supply operating range
Electromagnetic interference (EMI) filters Included
High common-mode input voltage range
 –2 V to +70 V operating
 –4 V to +85 V survival
Initial gain = 20 V/V
Wide operating temperature range: -40°C to $+125^\circ\text{C}$
Bidirectional operation
Available in 8-lead SOIC and 8-lead MSOP
Common-mode rejection ratio (CMRR): 86 dB, dc to 10 kHz
Qualified for automotive applications

APPLICATIONS

High-side current sensing in
 Motor controls
 Solenoid controls
 Power management
Low-side current sensing
Diagnostic protection

GENERAL DESCRIPTION

The **AD8418** is a high voltage, high resolution current shunt amplifier. It features an initial gain of 20 V/V, with a maximum $\pm 0.15\%$ gain error over the entire temperature range. The buffered output voltage directly interfaces with any typical converter. The **AD8418** offers excellent input common-mode rejection from –2 V to +70 V. The **AD8418** performs bidirectional current measurements across a shunt resistor in a variety of automotive and industrial applications, including motor control, battery management, and solenoid control.

The **AD8418** offers breakthrough performance throughout the -40°C to $+125^\circ\text{C}$ temperature range. It features a zero drift core, which leads to a typical offset drift of $0.1 \mu\text{V}/^\circ\text{C}$ throughout the operating temperature range and the common-mode voltage range. The **AD8418** is fully qualified for automotive applications and includes EMI filters and patented circuitry to enable output accuracy with pulse-width modulation (PWM) type input common-mode voltages. The typical input offset voltage is $\pm 200 \mu\text{V}$. The **AD8418** is offered in 8-lead MSOP and SOIC packages.

Table 1. Related Devices

Part No.	Description
AD8205	Current sense amplifier, gain = 50
AD8206	Current sense amplifier, gain = 20
AD8207	High accuracy current sense amplifier, gain = 20
AD8210	High speed current sense amplifier, gain = 20

FUNCTIONAL BLOCK DIAGRAM

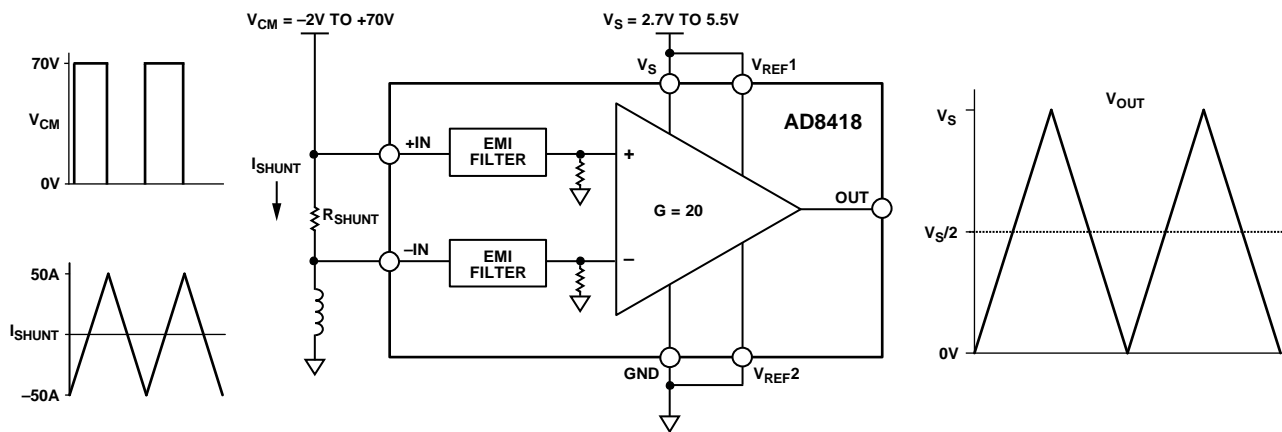

Figure 1.

Rev. 0

[Document Feedback](#)

Information furnished by Analog Devices is believed to be accurate and reliable. However, no responsibility is assumed by Analog Devices for its use, nor for any infringements of patents or other rights of third parties that may result from its use. Specifications subject to change without notice. No license is granted by implication or otherwise under any patent or patent rights of Analog Devices. Trademarks and registered trademarks are the property of their respective owners.

One Technology Way, P.O. Box 9106, Norwood, MA 02062-9106, U.S.A.
 Tel: 781.329.4700 ©2013 Analog Devices, Inc. All rights reserved.
[Technical Support](#) www.analog.com

TABLE OF CONTENTS

Features	1	Unidirectional Operation.....	11
Applications.....	1	Bidirectional Operation.....	11
General Description	1	External Referenced Output	12
Functional Block Diagram	1	Splitting the Supply	12
Revision History	2	Splitting an External Reference	12
Specifications.....	3	Applications Information	13
Absolute Maximum Ratings.....	4	Motor Control.....	13
ESD Caution.....	4	Solenoid Control	14
Pin Configuration and Function Descriptions.....	5	Outline Dimensions	15
Typical Performance Characteristics	6	Ordering Guide	16
Theory of Operation	10	Automotive Products.....	16
Output Offset Adjustment.....	11		

REVISION HISTORY

9/13—Revision 0: Initial Version

SPECIFICATIONS

$T_A = -40^{\circ}\text{C}$ to $+125^{\circ}\text{C}$ (operating temperature range), $V_S = 5\text{ V}$, unless otherwise noted.

Table 2.

Parameter	Test Conditions/Comments	Min	Typ	Max	Unit
GAIN					
Initial			20		V/V
Error Over Temperature	Specified temperature range			± 0.15	%
Gain vs. Temperature		-8		+8	ppm/ $^{\circ}\text{C}$
VOLTAGE OFFSET					
Offset Voltage, Referred to the Input (RTI)	25 $^{\circ}\text{C}$		± 200		μV
Over Temperature (RTI)	Specified temperature range			± 400	μV
Offset Drift		-1	+0.1	+1	$\mu\text{V}/^{\circ}\text{C}$
INPUT					
Input Bias Current			130		μA
Input Voltage Range	Common mode, continuous	-2		+70	V
Common-Mode Rejection Ratio (CMRR)	Specified temperature range, $f = \text{dc}$ $f = \text{dc}$ to 10 kHz	90	100		dB
			86		dB
OUTPUT					
Output Voltage Range	$R_L = 25\text{ k}\Omega$	0.015		$V_S - 0.020$	V
Output Resistance			2		Ω
DYNAMIC RESPONSE					
Small Signal -3 dB Bandwidth			250		kHz
Slew Rate			1		V/ μs
NOISE					
0.1 Hz to 10 Hz (RTI)			2.3		$\mu\text{V p-p}$
Spectral Density, 1 kHz (RTI)			110		nV/ $\sqrt{\text{Hz}}$
OFFSET ADJUSTMENT					
Ratiometric Accuracy ¹	Divider to supplies	0.4995		0.5005	V/V
Accuracy, Referred to the Output (RTO)	Voltage applied to $V_{\text{REF}1}$ and $V_{\text{REF}2}$ in parallel			± 1	mV/V
Output Offset Adjustment Range	$V_S = 5\text{ V}$	0.015		$V_S - 0.020$	V
POWER SUPPLY					
Operating Range		2.7		5.5	V
Quiescent Current Over Temperature	$V_{\text{OUT}} = 0.1\text{ V dc}$			2.6	mA
Power Supply Rejection Ratio		80			dB
Temperature Range					
For Specified Performance	Operating temperature range	-40		+125	$^{\circ}\text{C}$

¹ The offset adjustment is ratiometric to the power supply when $V_{\text{REF}1}$ and $V_{\text{REF}2}$ are used as a divider between the supplies.

ABSOLUTE MAXIMUM RATINGS

Table 3.

Parameter	Rating
Supply Voltage	6 V
Input Voltage Range	
Continuous	–2 V to +70 V
Survival	–4 V to +85 V
Differential Input Survival	±5.5 V
Reverse Supply Voltage	0.3 V
ESD Human Body Model (HBM)	±2000 V
Operating Temperature Range	–40°C to +125°C
Storage Temperature Range	–65°C to +150°C
Output Short-Circuit Duration	Indefinite

Stresses above those listed under Absolute Maximum Ratings may cause permanent damage to the device. This is a stress rating only; functional operation of the device at these or any other conditions above those indicated in the operational section of this specification is not implied. Exposure to absolute maximum rating conditions for extended periods may affect device reliability.

ESD CAUTION



ESD (electrostatic discharge) sensitive device. Charged devices and circuit boards can discharge without detection. Although this product features patented or proprietary protection circuitry, damage may occur on devices subjected to high energy ESD. Therefore, proper ESD precautions should be taken to avoid performance degradation or loss of functionality.

PIN CONFIGURATION AND FUNCTION DESCRIPTIONS

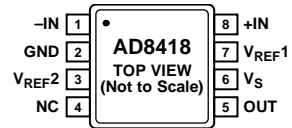

NC = NO CONNECT. DO NOT
CONNECT TO THIS PIN.

1154E-002

Figure 2. Pin Configuration

Table 4. Pin Function Descriptions

Pin No.	Mnemonic	Description
1	-IN	Negative Input.
2	GND	Ground.
3	V _{REF2}	Reference Input 2.
4	NC	No Connect. Do not connect to this pin.
5	OUT	Output.
6	V _S	Supply.
7	V _{REF1}	Reference Input 1.
8	+IN	Positive Input.

TYPICAL PERFORMANCE CHARACTERISTICS

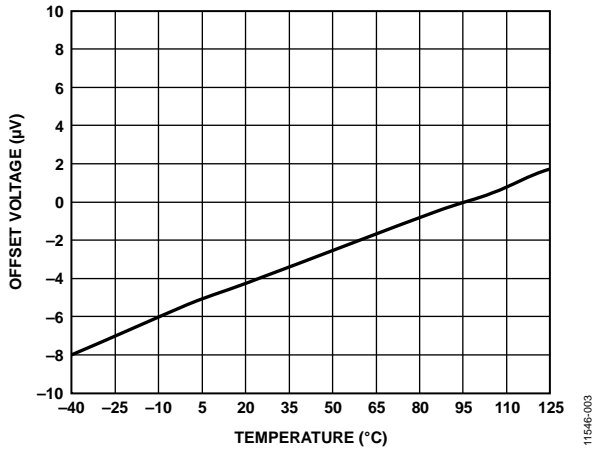

Figure 3. Typical Offset Drift vs. Temperature

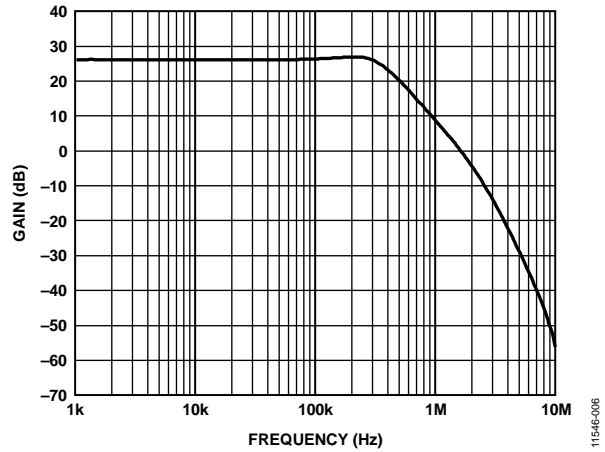

Figure 6. Typical Small Signal Bandwidth ($V_{OUT} = 200\text{ mV p-p}$)

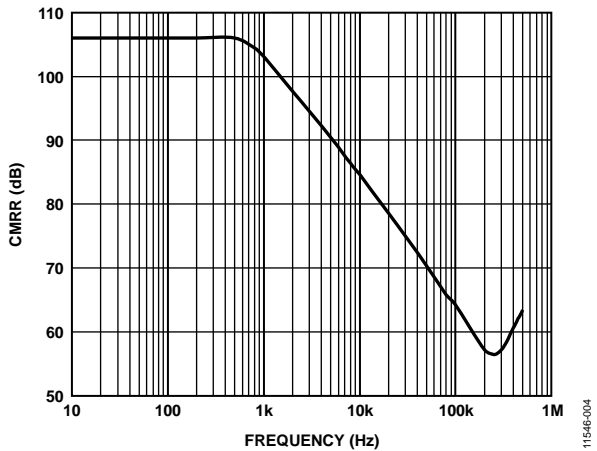

Figure 4. Typical CMRR vs. Frequency

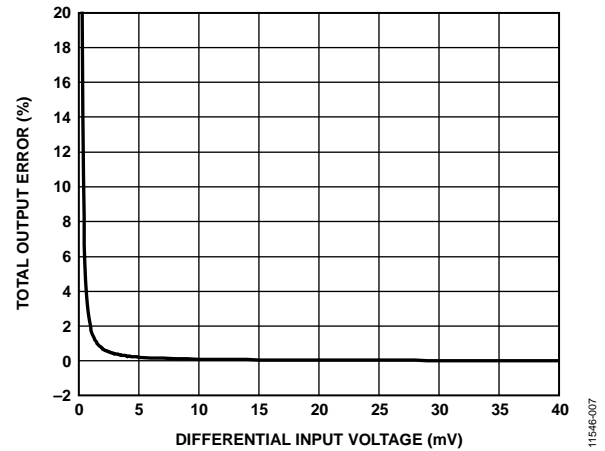

Figure 7. Total Output Error vs. Differential Input Voltage

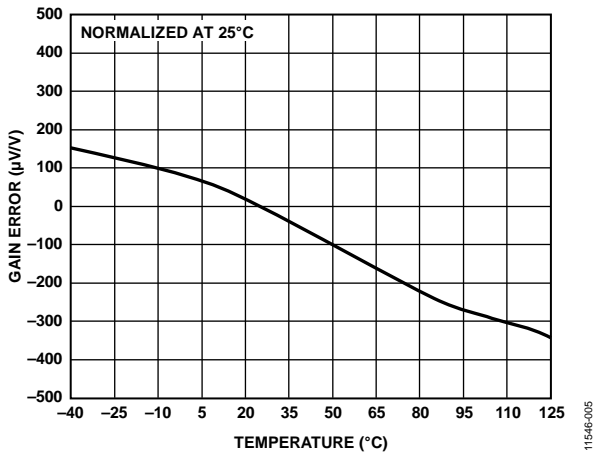

Figure 5. Typical Gain Error vs. Temperature

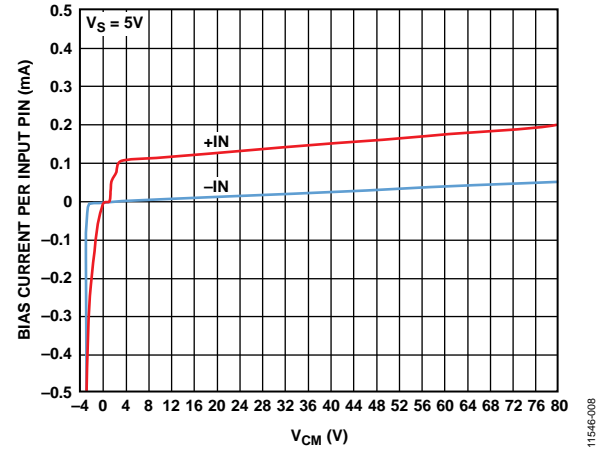

Figure 8. Bias Current per Input Pin vs. Common-Mode Voltage (V_{CM})

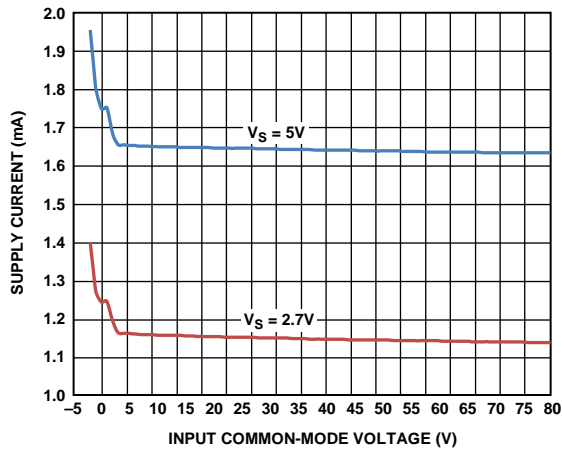

Figure 9. Supply Current vs. Input Common-Mode Voltage

11546-009

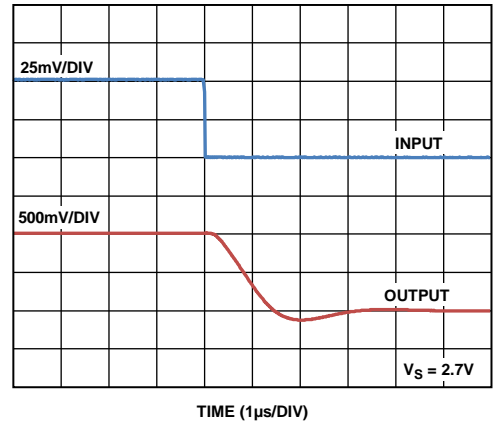

Figure 12. Fall Time ($V_S = 2.7\text{ V}$)

11546-012

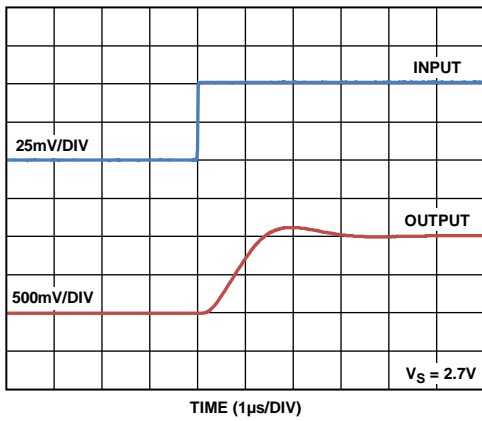

Figure 10. Rise Time ($V_S = 2.7\text{ V}$)

11546-010

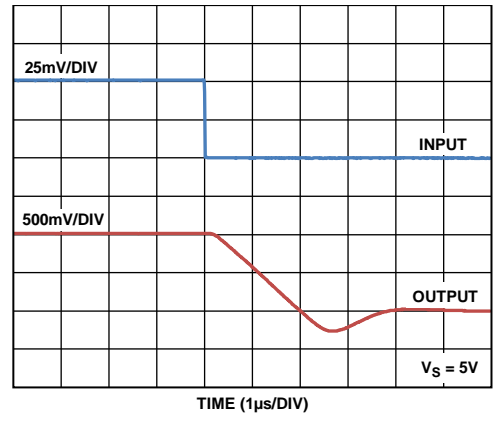

Figure 13. Fall Time ($V_S = 5\text{ V}$)

11546-013

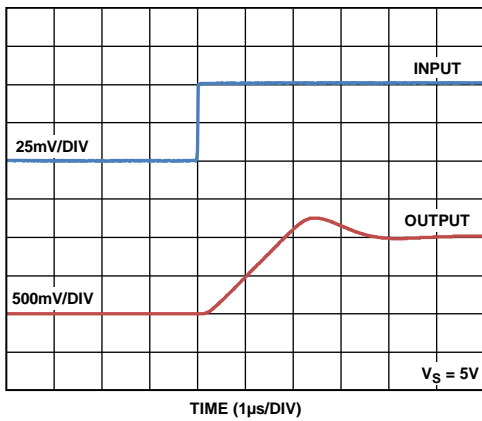

Figure 11. Rise Time ($V_S = 5\text{ V}$)

11546-011

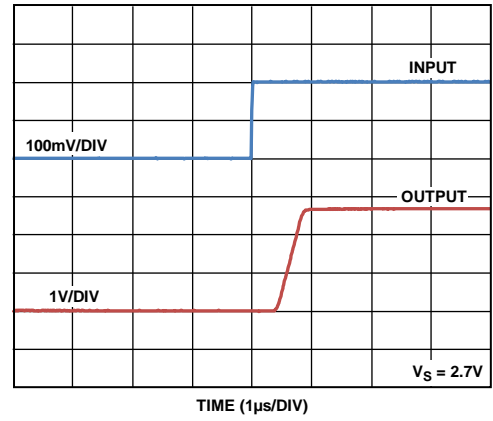

Figure 14. Differential Overload Recovery, Rising ($V_S = 2.7\text{ V}$)

11546-014

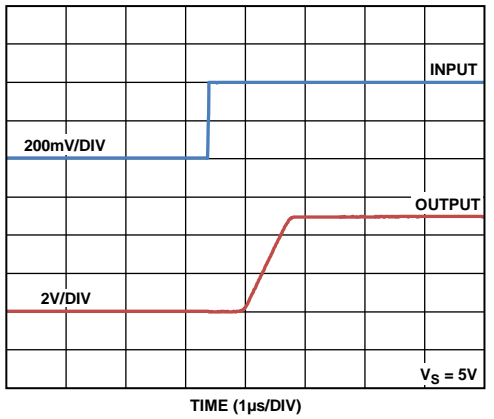

Figure 15. Differential Overload Recovery, Rising ($V_S = 5\text{ V}$)

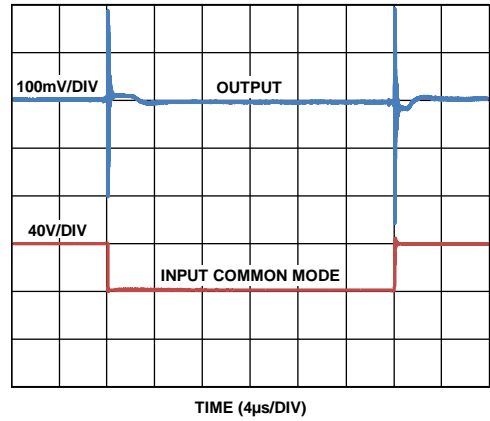

Figure 18. Input Common-Mode Step Response ($V_S = 5\text{ V}$, Inputs Shorted)

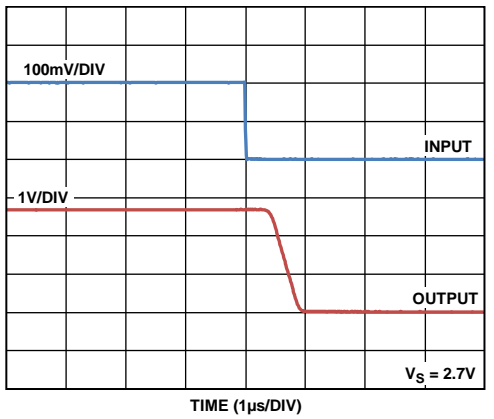

Figure 16. Differential Overload Recovery, Falling ($V_S = 2.7\text{ V}$)

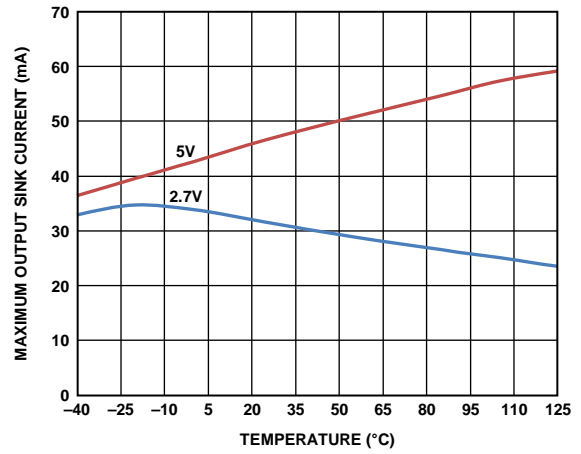

Figure 19. Maximum Output Sink Current vs. Temperature

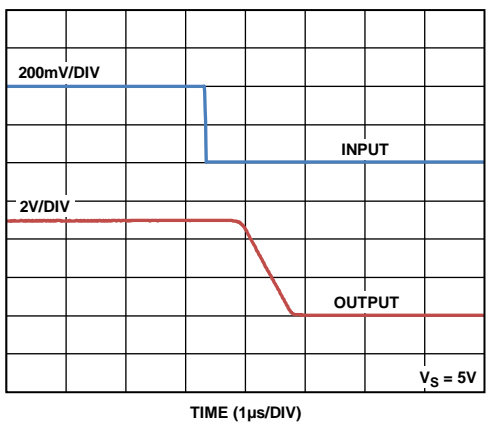

Figure 17. Differential Overload Recovery, Falling ($V_S = 5\text{ V}$)

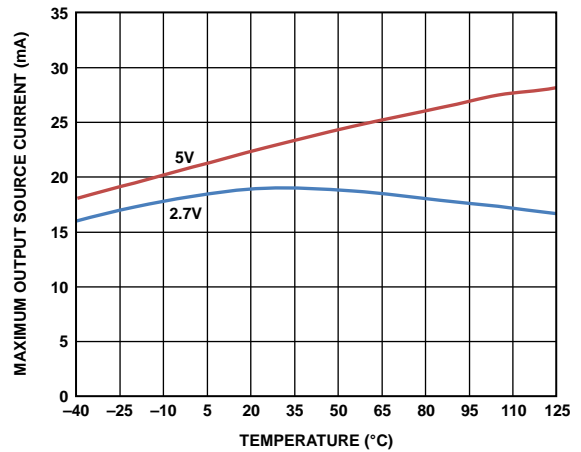

Figure 20. Maximum Output Source Current vs. Temperature

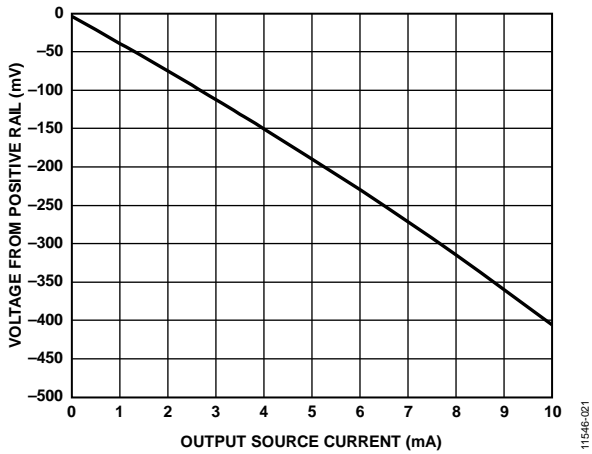

Figure 21. Output Voltage Range from Positive Rail vs. Output Source Current

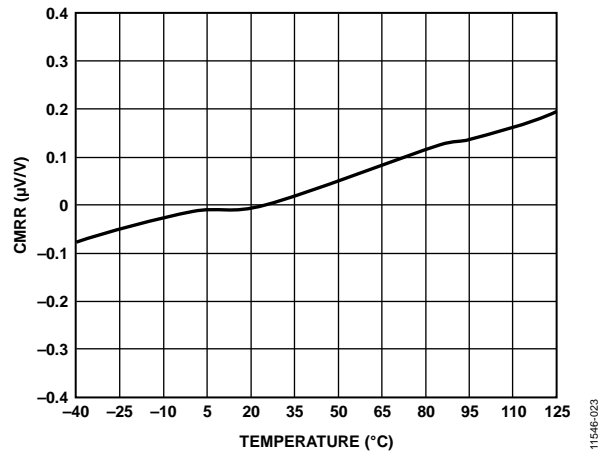

Figure 24. CMRR vs. Temperature

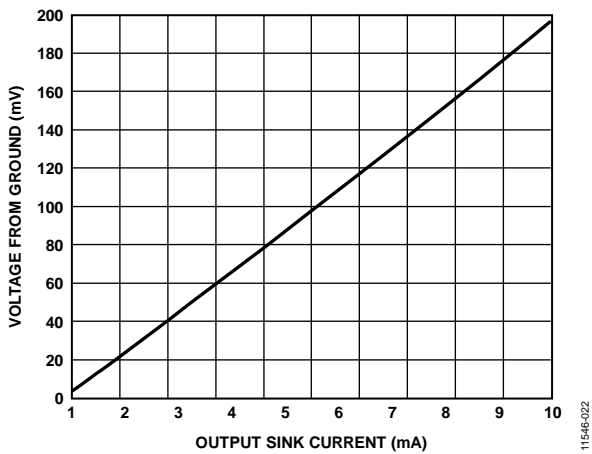

Figure 22. Output Voltage Range from Ground vs. Output Sink Current

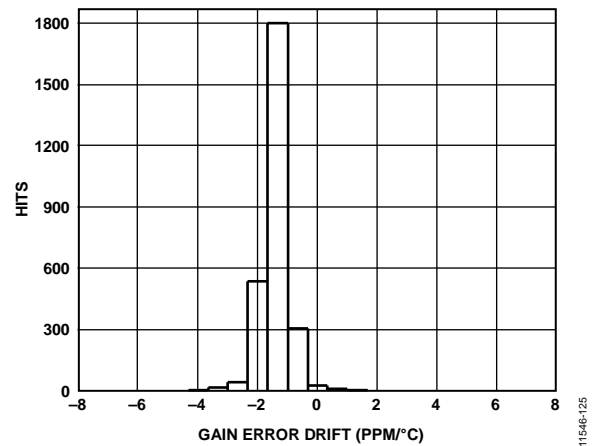

Figure 25. Gain Drift Distribution

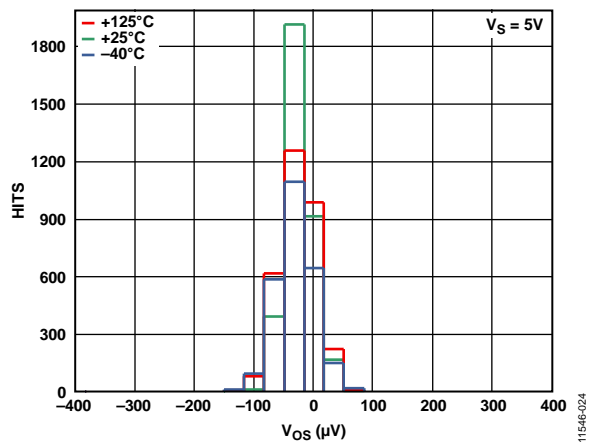

Figure 23. Offset Voltage Distribution

THEORY OF OPERATION

The AD8418 is a single-supply, zero drift, difference amplifier that uses a unique architecture to accurately amplify small differential current shunt voltages in the presence of rapidly changing common-mode voltages.

In typical applications, the AD8418 is used to measure current by amplifying the voltage across a shunt resistor connected to its inputs by a gain of 20 V/V (see Figure 26).

The AD8418 is designed to provide excellent common-mode rejection, even with PWM common-mode inputs that can change at very fast rates, for example, 1 V/ns. The AD8418 contains patented technology to eliminate the negative effects of such fast changing external common-mode variations.

The AD8418 features an input offset drift of less than 500 nV/°C. This performance is achieved through a novel zero drift architecture that does not compromise bandwidth, which is typically rated at 250 kHz.

The reference inputs, V_{REF1} and V_{REF2} , are tied through 100 k Ω resistors to the positive input of the main amplifier, which allows the output offset to be adjusted anywhere in the output operating range. The gain is 1 V/V from the reference pins to the output when the reference pins are used in parallel. When the pins are used to divide the supply, the gain is 0.5 V/V.

The AD8418 offers breakthrough performance without compromising any of the robust application needs typical of solenoid or motor control. The ability to reject PWM input common-mode voltages and the zero drift architecture providing low offset and offset drift allows the AD8418 to deliver total accuracy for these demanding applications.

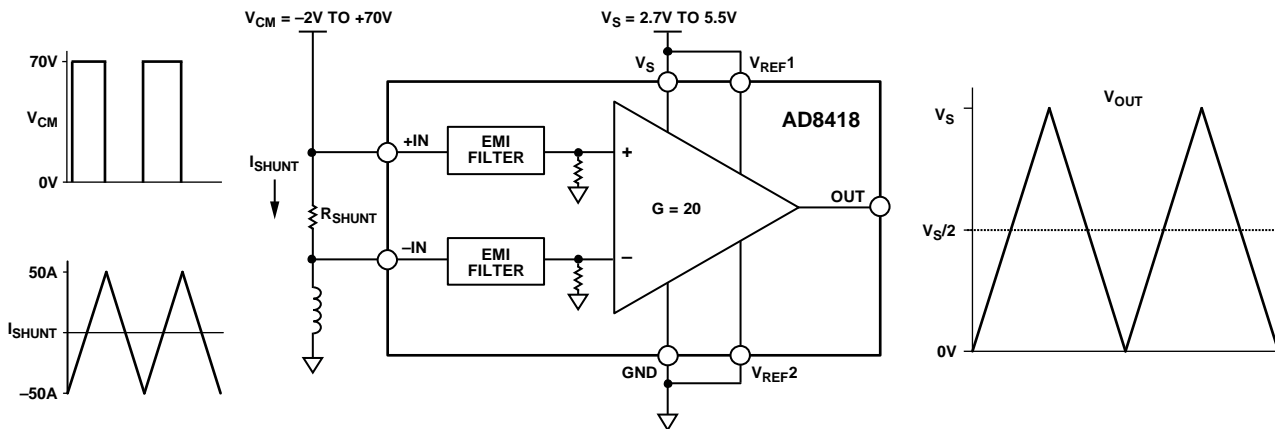

Figure 26. Typical Application

11546-225

OUTPUT OFFSET ADJUSTMENT

The output of the AD8418 can be adjusted for unidirectional or bidirectional operation.

UNIDIRECTIONAL OPERATION

Unidirectional operation allows the AD8418 to measure currents through a resistive shunt in one direction. The basic modes for unidirectional operation are ground referenced output mode and V_S referenced output mode.

For unidirectional operation, the output can be set at the negative rail (near ground) or at the positive rail (near V_S) when the differential input is 0 V. The output moves to the opposite rail when a correct polarity differential input voltage is applied. The required polarity of the differential input depends on the output voltage setting. If the output is set at the positive rail, the input polarity needs to be negative to move the output down. If the output is set at ground, the polarity must be positive to move the output up.

Ground Referenced Output

When using the AD8418 in this mode, both referenced inputs are tied to ground, which causes the output to sit at the negative rail when there are zero differential volts at the input (see Figure 27).

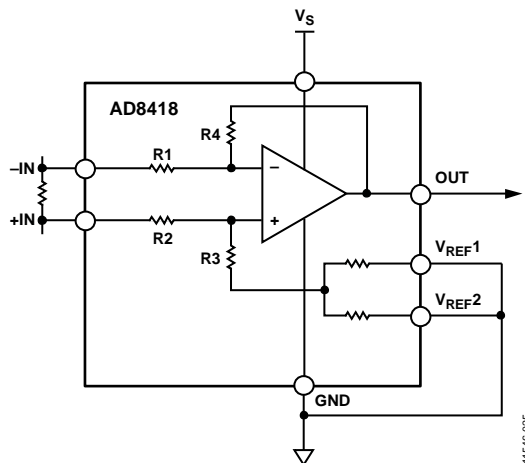

Figure 27. Ground Referenced Output

V_S Referenced Output

This mode is set when both reference pins are tied to the positive supply. It is typically used when the diagnostic scheme requires detection of the amplifier and the wiring before power is applied to the load (see Figure 28).

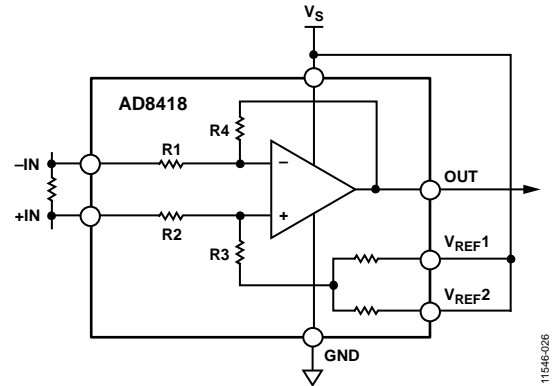

Figure 28. V_S Referenced Output

BIDIRECTIONAL OPERATION

Bidirectional operation allows the AD8418 to measure currents through a resistive shunt in two directions.

In this case, the output is set anywhere within the output range. Typically, it is set at half-scale for equal range in both directions. In some cases, however, it is set at a voltage other than half scale when the bidirectional current is nonsymmetrical.

Adjusting the output is accomplished by applying voltage(s) to the referenced inputs.

V_{REF1} and V_{REF2} are tied to internal resistors that connect to an internal offset node. There is no operational difference between the pins.

EXTERNAL REFERENCED OUTPUT

Tying both pins together and to a reference produces an output equal to the reference voltage when there is no differential input (see Figure 29). The output moves down from the reference voltage when the input is negative, relative to the $-IN$ pin, and up when the input is positive, relative to the $-IN$ pin.

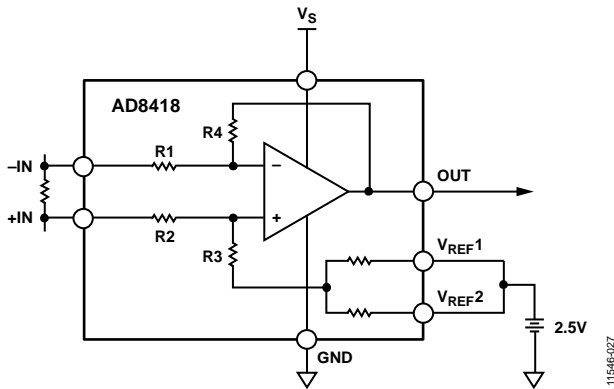

Figure 29. External Referenced Output

SPLITTING THE SUPPLY

By tying one reference pin to V_S and the other to the ground pin, the output is set at half of the supply when there is no differential input (see Figure 30). The benefit is that an external reference is not required to offset the output for bidirectional current measurement. Tying one reference pin to V_S and the other to the ground pin creates a midscale offset that is ratiometric to the supply, which means that if the supply increases or decreases, the output remains at half the supply. For example, if the supply is 5.0 V, the output is at half scale or 2.5 V. If the supply increases by 10% (to 5.5 V), the output goes to 2.75 V.

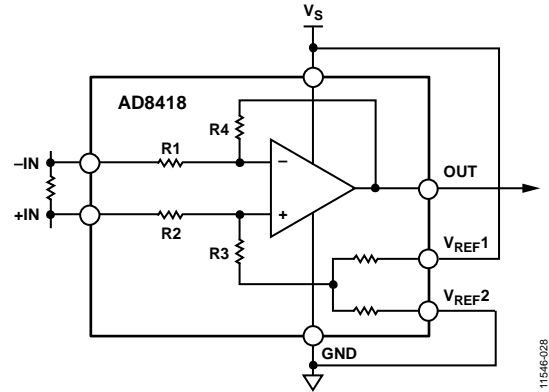

Figure 30. Split Supply

SPLITTING AN EXTERNAL REFERENCE

The internal reference resistors can be used to divide an external reference by 2 with an accuracy of approximately 0.5%. Splitting an external reference can be done by connecting one V_{REFX} pin to ground and the other V_{REFX} pin to the reference (see Figure 31).

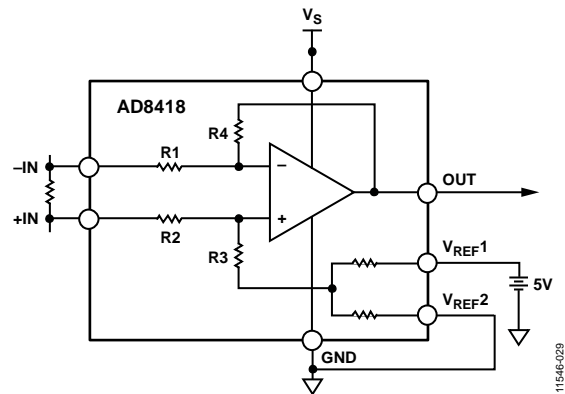

Figure 31. Split External Reference

APPLICATIONS INFORMATION

MOTOR CONTROL

3-Phase Motor Control

The AD8418 is ideally suited for monitoring current in 3-phase motor applications.

The 250 kHz typical bandwidth of the AD8418 allows instantaneous current monitoring. Additionally, the typical low offset drift of $0.1 \mu\text{V}/^\circ\text{C}$ means that the measurement error between the two motor phases is at a minimum over temperature. The AD8418 rejects PWM input common-mode voltages in the -2 V to $+70 \text{ V}$ (with a 5 V supply) range. Monitoring the current on the motor phase allows sampling of the current at any point and provides diagnostic information such as a short to GND and battery. Refer to Figure 33 for the typical phase current measurement setup with the AD8418.

H-Bridge Motor Control

Another typical application for the AD8418 is as part of the control loop in H-bridge motor control. In this case, the shunt resistor is placed in the middle of the H-bridge so that it can accurately measure current in both directions by using the shunt available at the motor (see Figure 32). Using an amplifier and shunt in this location is a better solution than a ground

referenced op amp because ground is not typically a stable reference voltage in this type of application. The instability of the ground reference causes inaccuracies in the measurements that can be made with a simple ground referenced op amp. The AD8418 measures current in both directions as the H-bridge switches and the motor changes direction. The output of the AD8418 is configured in an external referenced bidirectional mode (see the Bidirectional Operation section).

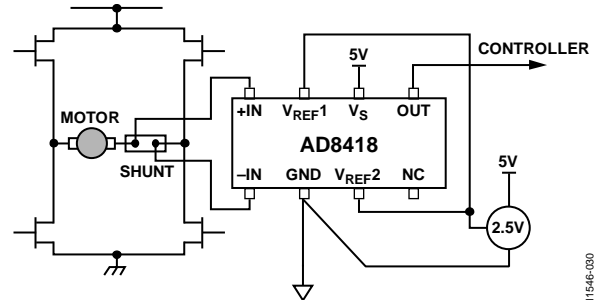

Figure 32. H-Bridge Motor Control

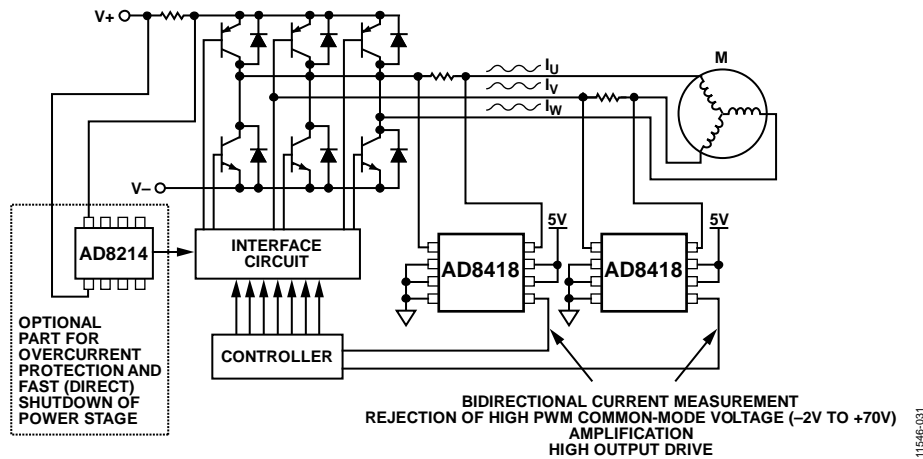

Figure 33. 3-Phase Motor Control

SOLENOID CONTROL

High-Side Current Sense with a Low-Side Switch

In the case of a high-side current sense with a low-side switch, the PWM control switch is ground referenced. An inductive load (solenoid) is tied to a power supply. A resistive shunt is placed between the switch and the load (see Figure 34). An advantage of placing the shunt on the high side is that the entire current, including the recirculation current, can be measured because the shunt remains in the loop when the switch is off. In addition, diagnostics can be enhanced because shorts to ground can be detected with the shunt on the high side.

In this circuit configuration, when the switch is closed, the common-mode voltage moves down to near the negative rail. When the switch is open, the voltage reversal across the inductive load causes the common-mode voltage to be held one diode drop above the battery by the clamp diode.

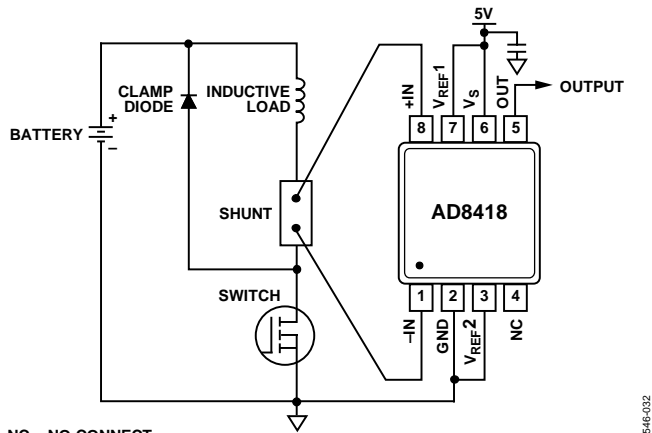

Figure 34. Low-Side Switch

High-Side Current Sense with a High-Side Switch

The high-side current sense with a high-side switch configuration minimizes the possibility of unexpected solenoid activation and excessive corrosion (see Figure 35). In this case, both the switch and the shunt are on the high side. When the switch is off, the battery is removed from the load, which prevents damage from potential shorts to ground while still allowing the recirculating current to be measured and to provide diagnostics. Removing the power supply from the load for the majority of the time minimizes the corrosive effects that can be caused by the differential voltage between the load and ground.

When using a high-side switch, the battery voltage is connected to the load when the switch is closed, causing the common-mode voltage to increase to the battery voltage. In this case, when the switch is open, the voltage reversal across the inductive load causes the common-mode voltage to be held one diode drop below ground by the clamp diode.

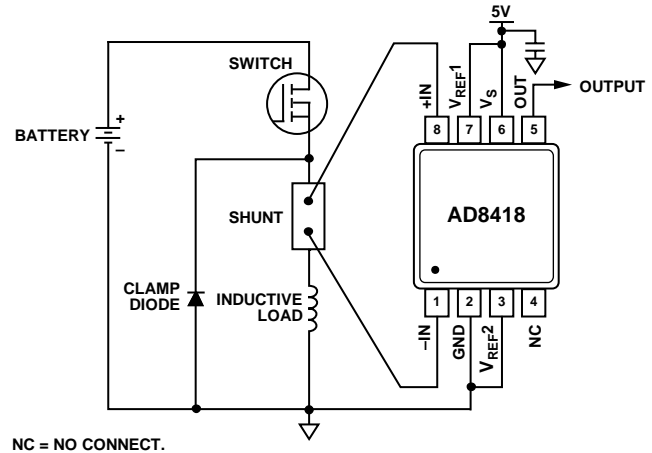

Figure 35. High-Side Switch

High Rail Current Sensing

In the high rail, current sensing configuration, the shunt resistor is referenced to the battery. High voltage is present at the inputs of the current sense amplifier. When the shunt is battery referenced, the AD8418 produces a linear ground referenced analog output. Additionally, the AD8214 can be used to provide an overcurrent detection signal in as little as 100 ns (see Figure 36). This feature is useful in high current systems where fast shutdown in overcurrent conditions is essential.

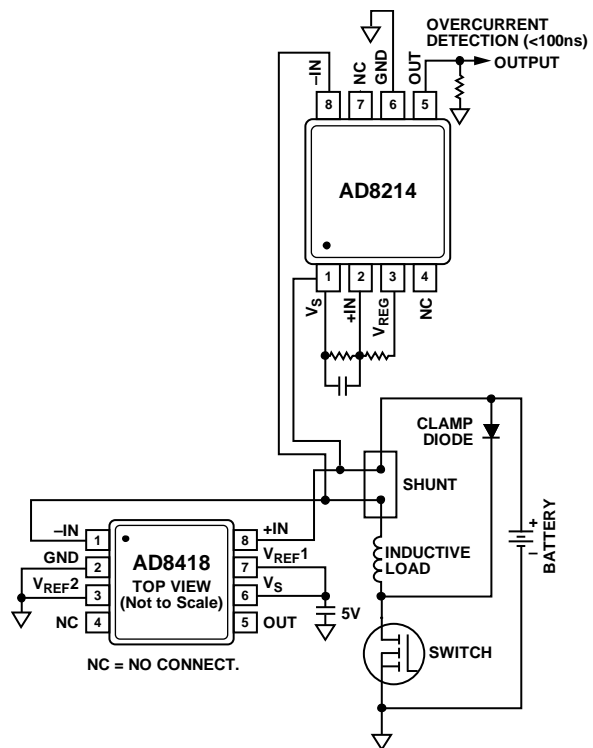
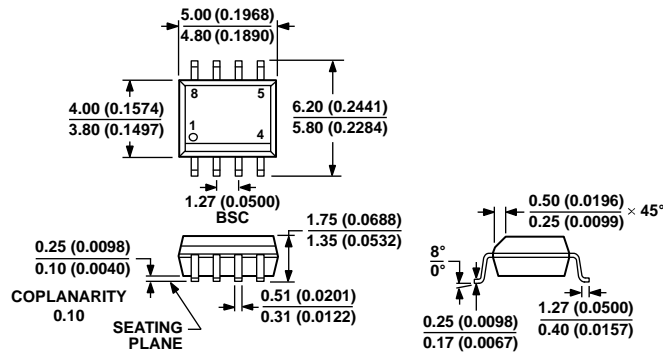

Figure 36. High Rail Current Sensing

OUTLINE DIMENSIONS



COMPLIANT TO JEDEC STANDARDS MS-012-AA
 CONTROLLING DIMENSIONS ARE IN MILLIMETERS; INCH DIMENSIONS
 (IN PARENTHESES) ARE ROUNDED-OFF MILLIMETER EQUIVALENTS FOR
 REFERENCE ONLY AND ARE NOT APPROPRIATE FOR USE IN DESIGN.

Figure 37. 8-Lead Standard Small Outline Package [SOIC_N]
 Narrow Body
 (R-8)

Dimensions shown in millimeters and (inches)

012407-A

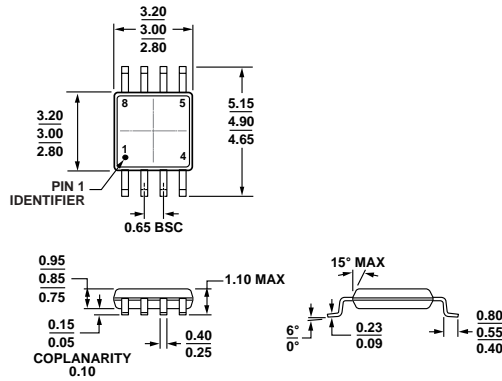

COMPLIANT TO JEDEC STANDARDS MO-187-AA

Figure 38. 8-Lead Mini Small Outline Package [MSOP]
 (RM-8)

Dimensions shown in millimeters

10-07-2008-B

ORDERING GUIDE

Model ^{1, 2}	Temperature Range	Package Description	Package Option	Branding
AD8418BRMZ	−40°C to +125°C	8-Lead MSOP	RM-8	Y4N
AD8418BRMZ-RL	−40°C to +125°C	8-Lead MSOP, 13" Tape and Reel	RM-8	Y4N
AD8418WBRMZ	−40°C to +125°C	8-Lead MSOP	RM-8	Y4M
AD8418WBRMZ-RL	−40°C to +125°C	8-Lead MSOP, 13" Tape and Reel	RM-8	Y4M
AD8418WBRZ	−40°C to +125°C	8-Lead SOIC_N	R-8	
AD8418WBRZ-RL	−40°C to +125°C	8-Lead SOIC_N, 13" Tape and Reel	R-8	

¹ Z = RoHS Compliant Part.

² W = Qualified for Automotive Applications.

AUTOMOTIVE PRODUCTS

The AD8418W models are available with controlled manufacturing to support the quality and reliability requirements of automotive applications. Note that these automotive models may have specifications that differ from the commercial models; therefore, designers should review the Specifications section of this data sheet carefully. Only the automotive grade products shown are available for use in automotive applications. Contact your local Analog Devices account representative for specific product ordering information and to obtain the specific Automotive Reliability reports for these models.

Looking for pricing, stock, or lifecycle information?

Click below to explore more details on WIN SOURCE:

- ⊖ [View AD8418WBRZ on WIN SOURCE](#)
- ⊖ [Analog Devices Inc. Information](#)

Optimize Your Supply Chain with WIN SOURCE Solutions

- ✓ Global Sourcing Solution
- ✓ Obsolete Management
- ✓ Cost Control Management
- ✓ Shortage Management
- ✓ Alternative Solution
- ✓ Excess Inventory Management