



**THE DATASHEET OF
SN74LS697N**



SN54LS696, SN54LS697, SN54LS699, SN74LS696, SN74LS697, SN74LS699
SYNCHRONOUS UP/DOWN COUNTERS
WITH OUTPUT REGISTERS AND MULTIPLEXED 3-STATE OUTPUTS
SDLS199 D2424, JANUARY 1981—REVISED MARCH 1988

- 4-Bit Counters/Registers
- Multiplexed Outputs for Counter or Latched Data
- 3-State Outputs Drive Bus Lines Directly
- 'LS696 . . . Decade Counter, Direct Clear
- 'LS697 . . . Binary Counter, Direct Clear
- 'LS699 . . . Binary Counter, Synchronous Clear

SN54LS696, SN54LS697,
SN54LS699 . . . J OR W PACKAGE
SN74LS696, SN74LS697,
SN74LS699 . . . DW OR N PACKAGE
(TOP VIEW)

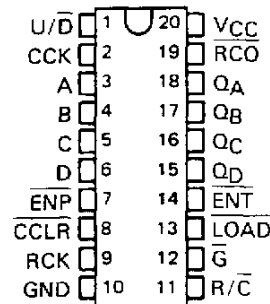

SN54LS696, SN54LS697,
SN54LS699 . . . FK PACKAGE
(TOP VIEW)

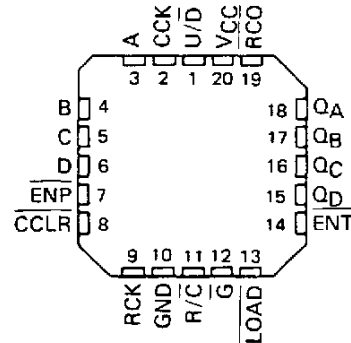

description

These low-power Schottky LSI devices incorporate synchronous up/down counters, four-bit D-type registers, and quadruple two-line to one-line multiplexers with three state outputs in a single 20-pin package. The up/down counters are programmable from the data inputs and feature enable \bar{P} and enable \bar{T} and a ripple-carry output for easy expansion. The register/counter select input R/\bar{C} , selects the counter when low and the register when high for the three-state outputs, Q_A , Q_B , Q_C , and Q_D . These outputs are rated at 12 and 24 milliamperes (54LS/74LS) for good bus driving performance.

Both the counter CCK and register clock RCK are positive-edge triggered. The counter clear \overline{CCLR} is active low and is asynchronous on the 'LS696 and 'LS697, synchronous on the 'LS699. Loading of the counter is accomplished when \overline{LOAD} is taken low and a positive transition occurs on the counter clock CCK.

Expansion is easily accomplished by connecting \overline{RCO} of the first stage to \overline{ENT} of the second stage, etc. All ENP inputs can be tied common and used as a master enable or disable control.

schematics of inputs and outputs

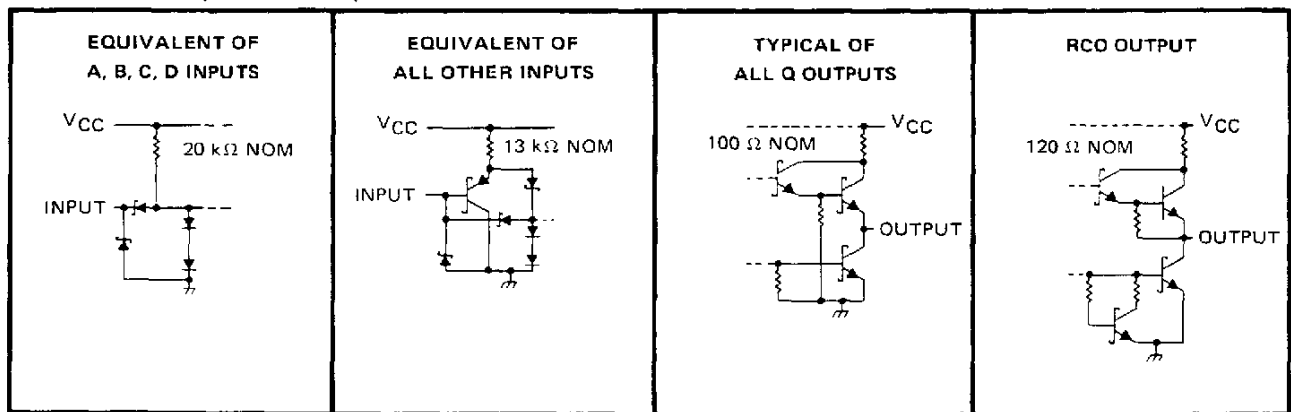

PRODUCTION DATA documents contain information current as of publication date. Products conform to specifications per the terms of Texas Instruments standard warranty. Production processing does not necessarily include testing of all parameters.



SN54LS696, SN54LS697, SN54LS699, SN74LS696, SN74LS697, SN74LS699
SYNCHRONOUS UP/DOWN COUNTERS
WITH OUTPUT REGISTERS AND MULTIPLEXED 3-STATE OUTPUTS

logic symbols†

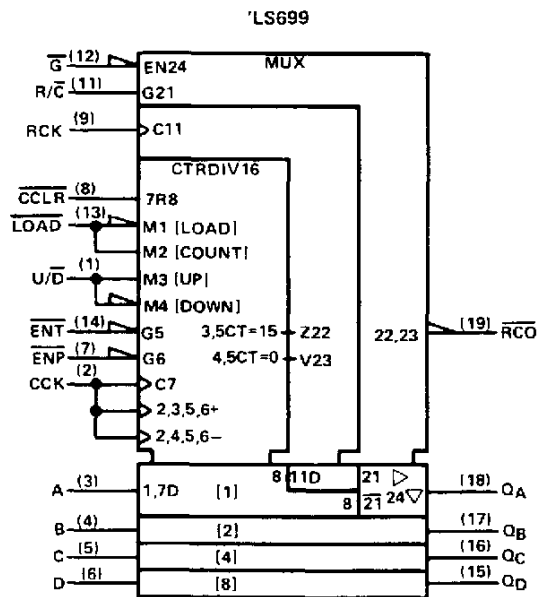
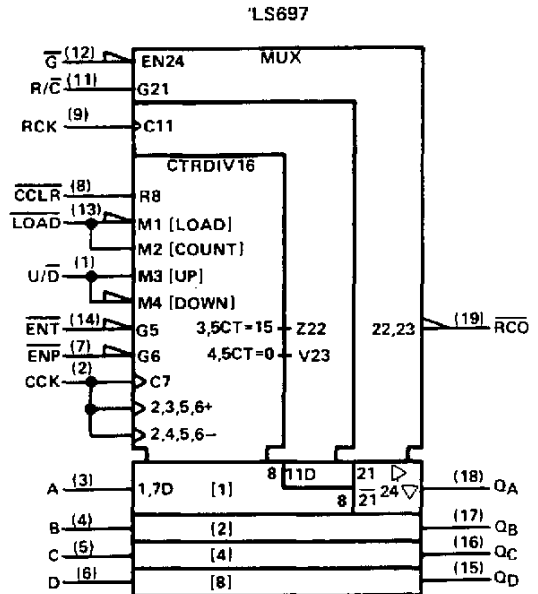
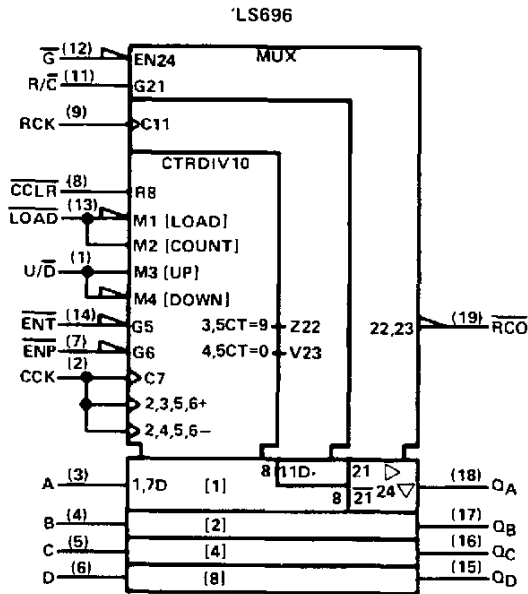

†These symbols are in accordance with ANSI/IEEE Std. 91-1984 and IEC Publication 617-12.

SN54LS696, SN74LS696
SYNCHRONOUS UP/DOWN COUNTERS
WITH OUTPUT REGISTERS AND MULTIPLEXED 3-STATE OUTPUTS

logic diagrams (positive logic)

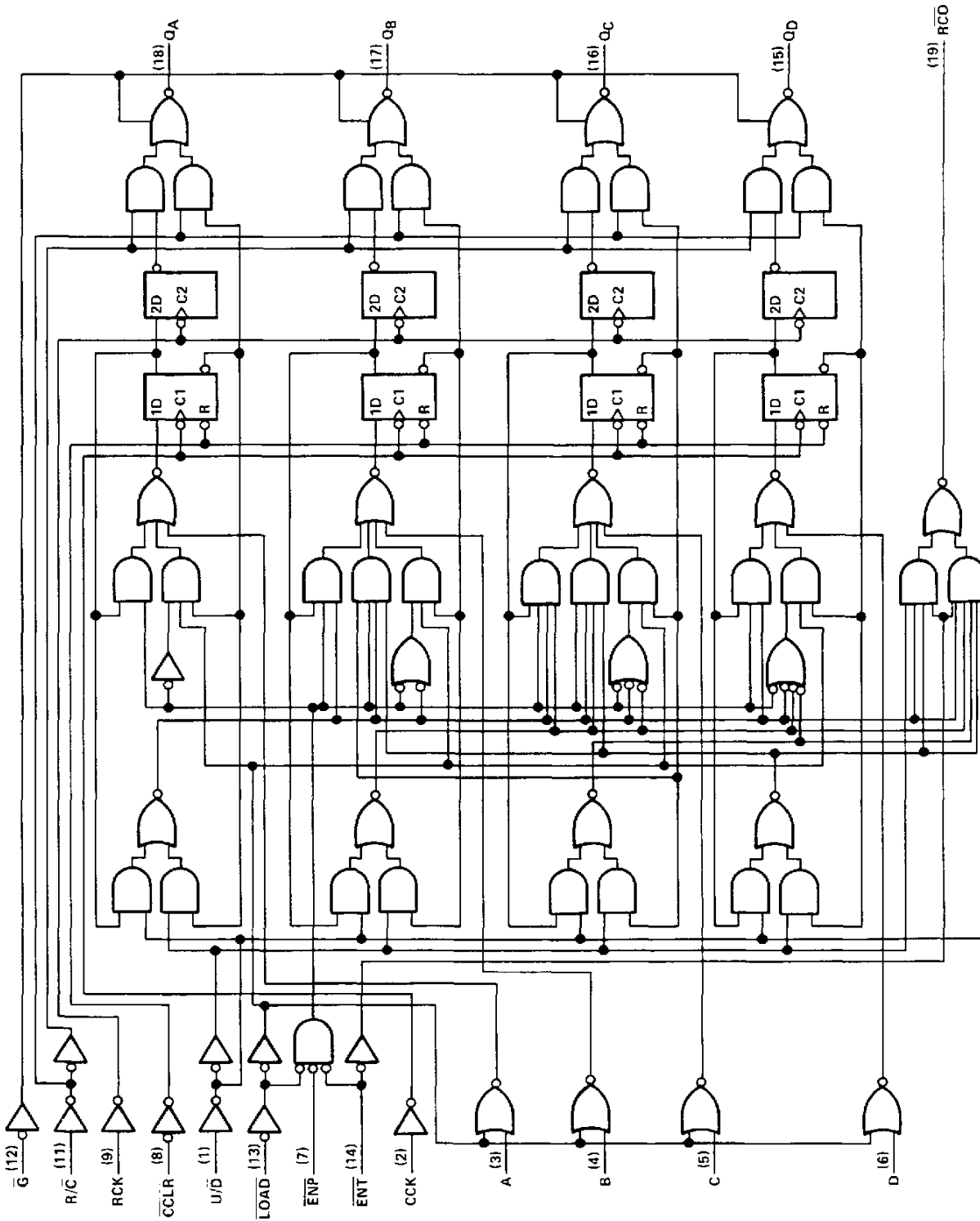

SN54LS697, SN74LS697
SYNCHRONOUS UP/DOWN COUNTERS
WITH OUTPUT REGISTERS AND MULTIPLEXED 3-STATE OUTPUTS

logic diagrams (positive logic) (continued)

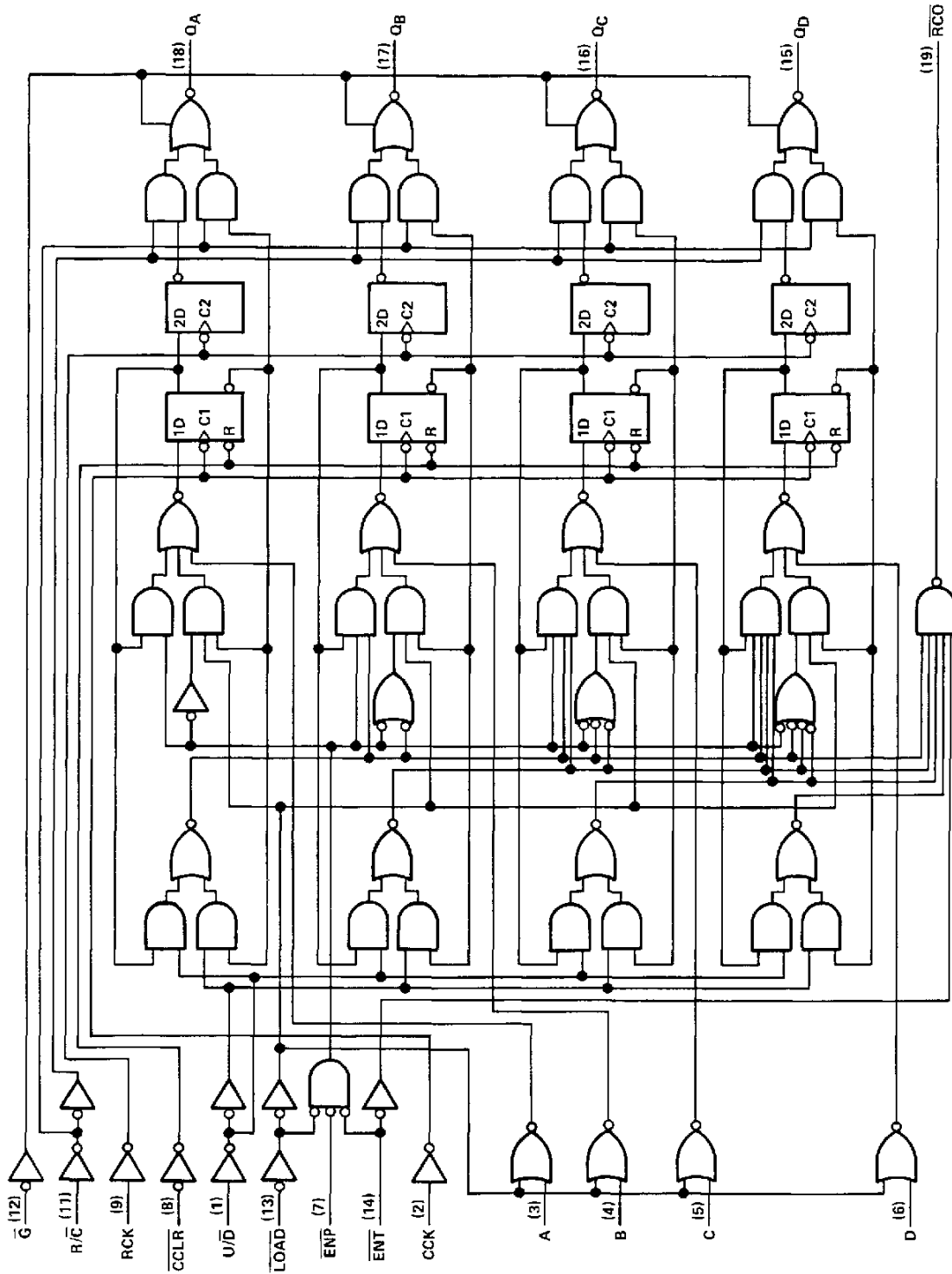

SN54LS698, SN74LS698
SYNCHRONOUS UP/DOWN COUNTERS
WITH OUTPUT REGISTERS AND MULTIPLEXED 3-STATE OUTPUTS

logic diagrams (positive logic) (continued)

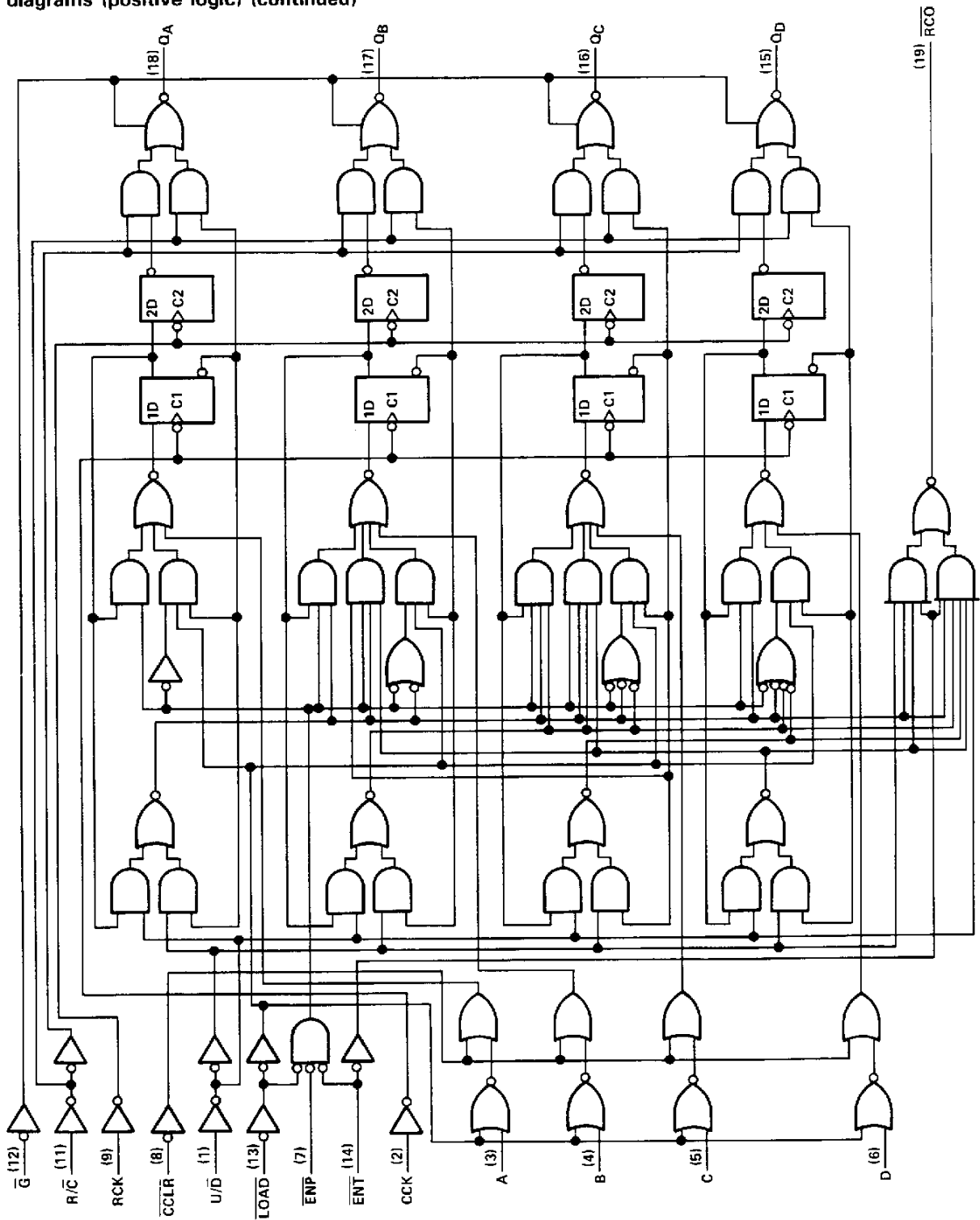

SN54LS699, SN74LS699
SYNCHRONOUS UP/DOWN COUNTERS
WITH OUTPUT REGISTERS AND MULTIPLEXED 3-STATE OUTPUTS

logic diagrams (positive logic) (continued)

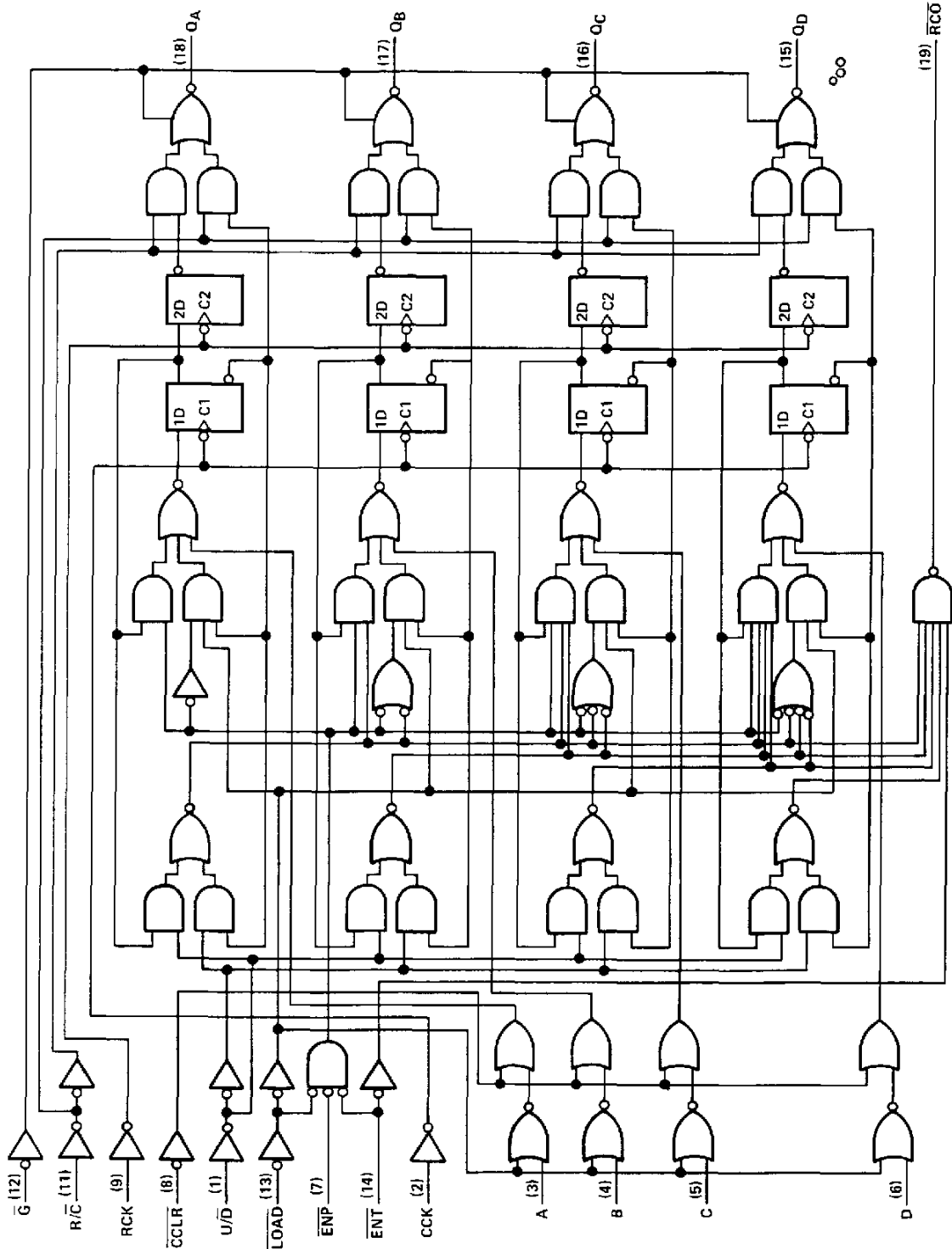

SN54LS696, SN54LS697, SN54LS699, SN74LS696, SN74LS697, SN74LS699
SYNCHRONOUS UP/DOWN COUNTERS
WITH OUTPUT REGISTERS AND MULTIPLEXED 3-STATE OUTPUTS

absolute maximum ratings over operating free-air temperature range (unless otherwise noted)

Supply voltage, V_{CC} (see Note 1)	7 V
Input voltage	7 V
Off-state output voltage	5.5 V
Operating free-air temperature range: SN54LS696, SN54LS697, SN54LS699	-55°C to 125°C
SN74LS696, SN74LS697, SN74LS699	0°C to 70°C
Storage temperature range	-65°C to 150°C

NOTE 1: Voltage values are with respect to network ground terminals.

recommended operating conditions

		SN54LS'			SN74LS'			UNIT
		MIN	NOM	MAX	MIN	NOM	MAX	
V_{CC}	Supply voltage	4.5	5	5.5	4.75	5	5.25	V
I_{OH}	High-level output current	Q		-1			-2.6	mA
		\overline{RCD}		-0.4			-0.4	
I_{OL}	Low-level output current	Q		12			24	mA
		\overline{RCD}		4			8	
f_{clock}	Clock frequency	CCK	0	20	0		20	MHz
		RCK	0	20	0		20	
t_w	Pulse duration	CCK high or low	25		25			ns
		RCK high or low	25		25			
		'LS696, 'LS697 \overline{CCLR} low	20		20			
t_{su}	Setup time before CCK ↑	A thru D	30		30			ns
		\overline{ENP} or \overline{ENT}	30		30			
		LOAD	30		30			
		U/\overline{D}	35		35			
		'LS696, 'LS697, \overline{CCLR} inactive	25		25			
'LS699, \overline{CCLR}	30		30					
t_{su}	Setup time CCK ↑ before RCK ↑ (see Note 2)	30		30			ns	
t_h	Hold time	0		0			ns	
T_A	Operating free-air temperature	-55		125	0		70	°C

NOTE 2: This set up time ensures the register will see stable data from the counter outputs. The clocks may be tied together in which case the register state will be one clock pulse behind the counter.



SN54LS696, SN54LS697, SN54LS699, SN74LS696, SN74LS697, SN74LS699
SYNCHRONOUS UP/DOWN COUNTERS
WITH OUTPUT REGISTERS AND MULTIPLEXED 3-STATE OUTPUTS

electrical characteristics over recommended operating free-air temperature range (unless otherwise noted)

PARAMETER		TEST CONDITIONS†	SN54LS'			SN74LS'			UNIT	
			MIN	TYP‡	MAX	MIN	TYP‡	MAX		
V _{IH}	High-level input voltage		2			2			V	
V _{IL}	Low-level input voltage		0.7			0.8			V	
V _{IK}	Input clamp voltage	V _{CC} =MIN, I _I =-18 mA	-1.5			-1.5			V	
V _{OH}	High-level output voltage	Any Q	V _{CC} =MIN, V _{IH} =2 V, V _{IL} =V _{IL} max	I _{OH} =-1 mA	2.4	3.1			V	
		Any Q		I _{OH} =-2.6 mA			2.4	3.1		
		\overline{RCO}		I _{OH} =-400 μ A	2.5	3.2	2.7	3.2		
V _{OL}	Low-level output voltage	Any Q	V _{CC} =MIN, V _{IH} =2 V, V _{IL} =V _{IL} max	I _{OL} =12 mA		0.25	0.4	0.25	0.4	V
		Any Q		I _{OL} =24 mA				0.35	0.5	
		\overline{RCO}		I _{OL} =4 mA		0.25	0.4	0.25	0.4	
		\overline{RCO}		I _{OL} =8 mA				0.35	0.5	
I _{OZH}	Off-state output current, high-level voltage applied	Any Q	V _{CC} =MAX, \overline{G} at 2 V, V _O =2.7 V			20		20	μ A	
I _{OZL}	Off-state output current, low-level voltage applied	Any Q	V _{CC} =MAX, \overline{G} at 2 V, V _O =0.4 V			-20		-20	μ A	
I _I	Input current at maximum input voltage		V _{CC} =MAX, V _I =7 V			0.1		0.1	mA	
I _{IH}	High-level input current		V _{CC} =MAX, V _I =2.7 V			20		20	μ A	
I _{IL}	Low-level input current	A thru D	V _{CC} =MAX, V _I =0.4 V			-0.4		-0.4	mA	
		All others				-0.2		-0.2		
I _{OS}	Short-circuit output current§	Any Q	V _{CC} =MAX, V _O =0 V		-30	-130	-30	-130	mA	
		\overline{RCO}			-20	-100	-20	-100		
I _{CCH}	Supply current, outputs high		V _{CC} =MAX, All outputs open	See Note 3	46	65	46	65	mA	
I _{CCL}	Supply current, outputs low	See Note 4		48	70	48	70			
I _{CCZ}	Supply current, outputs off	See Note 5		48	70	48	70			

† For conditions shown as MIN or MAX, use the appropriate value specified under recommended operating conditions.

‡ All typical values are at V_{CC} = 5 V, T_A = 25°C.

§ Only one output should be shorted at a time, and duration of the short-circuit should not exceed one second.

NOTES: 3. I_{CCH} is measured after two 4.5 V to 0 V to 4.5 V pulses have been applied to CCK and RCK while \overline{G} is grounded and all other inputs are at 4.5 V.

4. I_{CCL} is measured after two 0 V to 4.5 V to 0 V pulses have been applied to CCK and RCK while all other inputs are grounded.

5. I_{CCZ} is measured after two 0 V to 4.5 V to 0 V pulses have been applied to CCK and RCK while \overline{G} is at 4.5 V and all other inputs are grounded.

switching characteristics, V_{CC} = 5 V, T_A = 25°C (see note 6)

PARAMETER	FROM (INPUT)	TO (OUTPUT)	TEST CONDITIONS	'LS696, 'LS697			'LS699			UNIT
				MIN	TYP	MAX	MIN	TYP	MAX	
t _{PLH}	CCK↑	\overline{RCO}	R _L = 2 k Ω , C _L = 15 pF	23	40		23	40	ns	
t _{PHL}				23	40		23	40	ns	
t _{PLH}	\overline{ENT}	\overline{RCO}		13	20		13	20	ns	
t _{PHL}				13	20		13	20	ns	
t _{PLH}	CCK↑	Q		12	20		12	20	ns	
t _{PHL}				17	25		17	25	ns	
t _{PLH}	RCK↑	Q	12	20		12	20	ns		
t _{PHL}			17	25		17	25	ns		
t _{PHL}	CCLR↓	Q	23	40				ns		
t _{PLH}	R/ \overline{C}	Q	16	25		16	25	ns		
t _{PHL}			16	25		16	25	ns		
t _{PZH}	\overline{G} ↓	Q	19	30		19	30	ns		
t _{PZL}			19	30		19	30	ns		
t _{PHZ}	\overline{G} ↑	Q	17	30		17	30	ns		
t _{PLZ}			17	30		17	30	ns		

NOTE 6: Load circuits and voltage waveforms are shown in Section 1.



SN54LS696, SN74LS696
SYNCHRONOUS UP/DOWN COUNTERS
WITH OUTPUT REGISTERS AND MULTIPLEXED 3-STATE OUTPUTS

typical operating sequences

'LS696 DECADE COUNTER, Asynchronous Clear

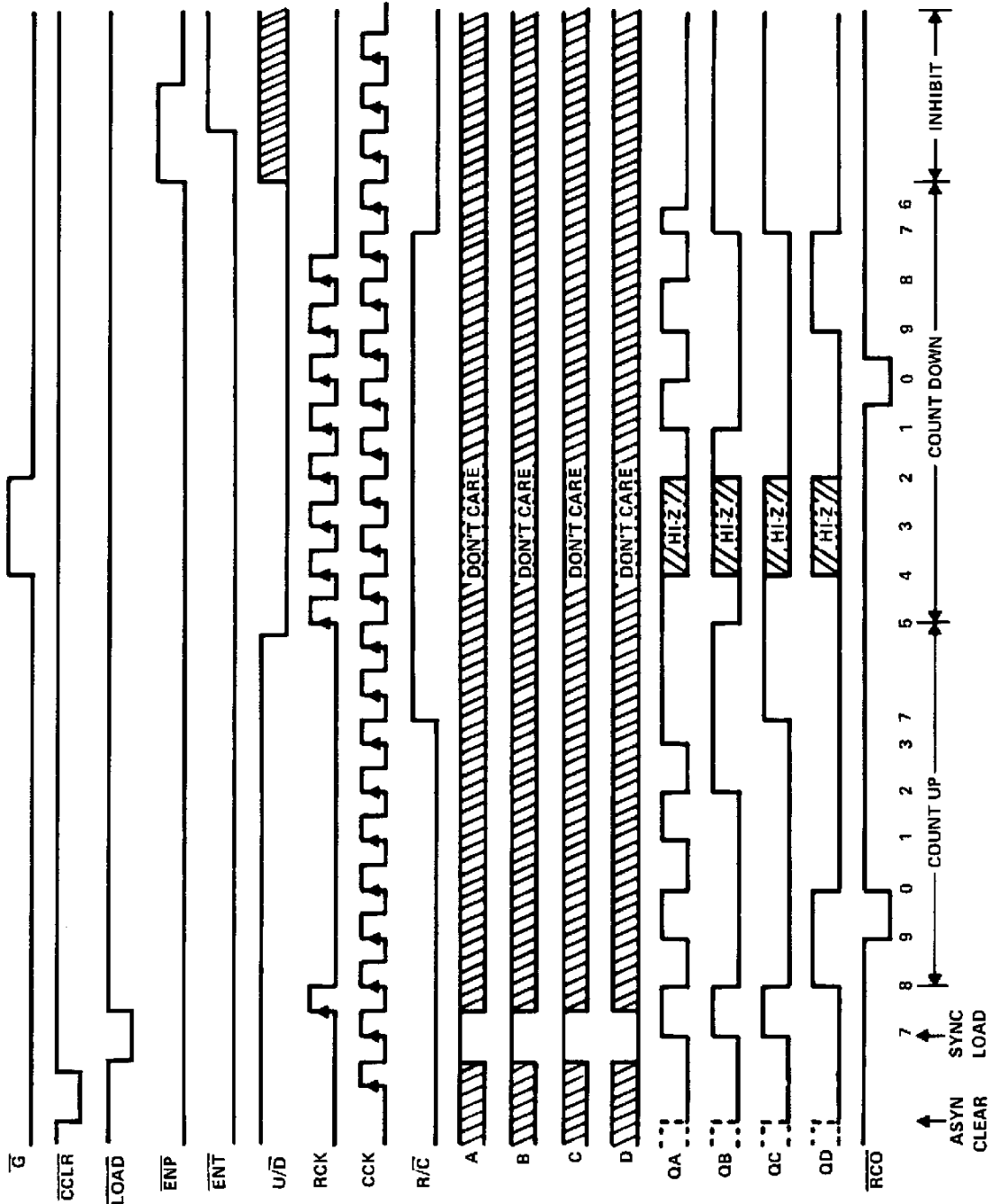

SN54LS697, SN54LS699, SN74LS697, SN74LS699
SYNCHRONOUS UP/DOWN COUNTERS
WITH OUTPUT REGISTERS AND MULTIPLEXED 3-STATE OUTPUTS

typical operating sequences (continued)

'LS697 BINARY COUNTER, Asynchronous Clear
 'LS699 BINARY COUNTER, Synchronous Clear

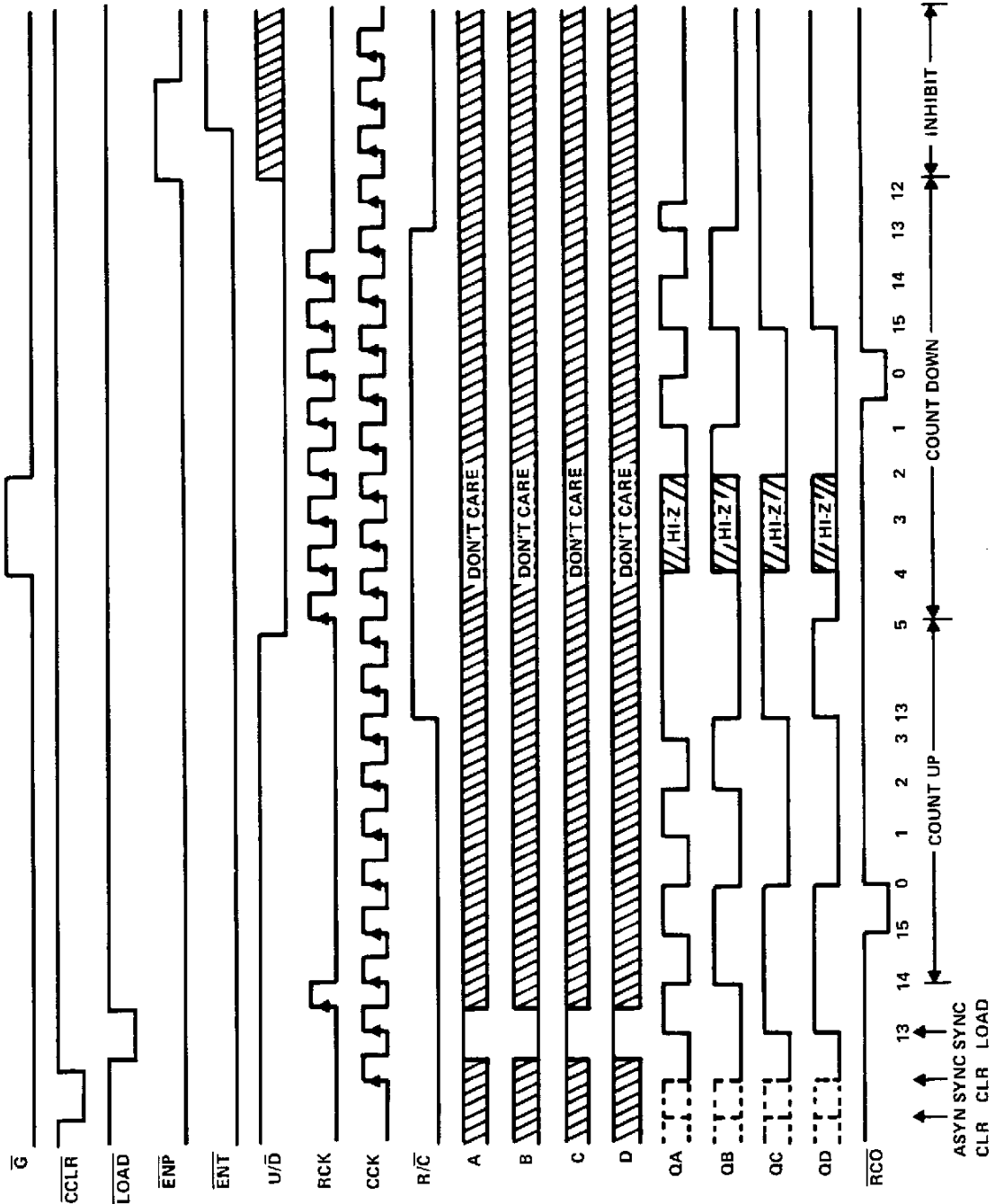

TAPE AND REEL INFORMATION



QUADRANT ASSIGNMENTS FOR PIN 1 ORIENTATION IN TAPE

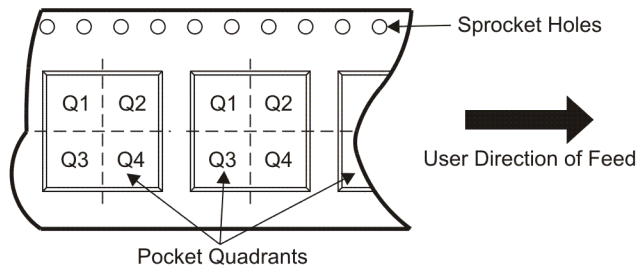

*All dimensions are nominal

Device	Package Type	Package Drawing	Pins	SPQ	Reel Diameter (mm)	Reel Width W1 (mm)	A0 (mm)	B0 (mm)	K0 (mm)	P1 (mm)	W (mm)	Pin1 Quadrant
SN74LS697NSR	SO	NS	20	2000	330.0	24.4	8.2	13.0	2.5	12.0	24.0	Q1

TAPE AND REEL BOX DIMENSIONS



*All dimensions are nominal

Device	Package Type	Package Drawing	Pins	SPQ	Length (mm)	Width (mm)	Height (mm)
SN74LS697NSR	SO	NS	20	2000	346.0	346.0	41.0

IMPORTANT NOTICE

Texas Instruments Incorporated and its subsidiaries (TI) reserve the right to make corrections, modifications, enhancements, improvements, and other changes to its products and services at any time and to discontinue any product or service without notice. Customers should obtain the latest relevant information before placing orders and should verify that such information is current and complete. All products are sold subject to TI's terms and conditions of sale supplied at the time of order acknowledgment.

TI warrants performance of its hardware products to the specifications applicable at the time of sale in accordance with TI's standard warranty. Testing and other quality control techniques are used to the extent TI deems necessary to support this warranty. Except where mandated by government requirements, testing of all parameters of each product is not necessarily performed.

TI assumes no liability for applications assistance or customer product design. Customers are responsible for their products and applications using TI components. To minimize the risks associated with customer products and applications, customers should provide adequate design and operating safeguards.

TI does not warrant or represent that any license, either express or implied, is granted under any TI patent right, copyright, mask work right, or other TI intellectual property right relating to any combination, machine, or process in which TI products or services are used. Information published by TI regarding third-party products or services does not constitute a license from TI to use such products or services or a warranty or endorsement thereof. Use of such information may require a license from a third party under the patents or other intellectual property of the third party, or a license from TI under the patents or other intellectual property of TI.

Reproduction of TI information in TI data books or data sheets is permissible only if reproduction is without alteration and is accompanied by all associated warranties, conditions, limitations, and notices. Reproduction of this information with alteration is an unfair and deceptive business practice. TI is not responsible or liable for such altered documentation. Information of third parties may be subject to additional restrictions.

Resale of TI products or services with statements different from or beyond the parameters stated by TI for that product or service voids all express and any implied warranties for the associated TI product or service and is an unfair and deceptive business practice. TI is not responsible or liable for any such statements.

TI products are not authorized for use in safety-critical applications (such as life support) where a failure of the TI product would reasonably be expected to cause severe personal injury or death, unless officers of the parties have executed an agreement specifically governing such use. Buyers represent that they have all necessary expertise in the safety and regulatory ramifications of their applications, and acknowledge and agree that they are solely responsible for all legal, regulatory and safety-related requirements concerning their products and any use of TI products in such safety-critical applications, notwithstanding any applications-related information or support that may be provided by TI. Further, Buyers must fully indemnify TI and its representatives against any damages arising out of the use of TI products in such safety-critical applications.

TI products are neither designed nor intended for use in military/aerospace applications or environments unless the TI products are specifically designated by TI as military-grade or "enhanced plastic." Only products designated by TI as military-grade meet military specifications. Buyers acknowledge and agree that any such use of TI products which TI has not designated as military-grade is solely at the Buyer's risk, and that they are solely responsible for compliance with all legal and regulatory requirements in connection with such use.

TI products are neither designed nor intended for use in automotive applications or environments unless the specific TI products are designated by TI as compliant with ISO/TS 16949 requirements. Buyers acknowledge and agree that, if they use any non-designated products in automotive applications, TI will not be responsible for any failure to meet such requirements.

Following are URLs where you can obtain information on other Texas Instruments products and application solutions:

Products

Amplifiers	amplifier.ti.com
Data Converters	dataconverter.ti.com
DLP® Products	www.dlp.com
DSP	dsp.ti.com
Clocks and Timers	www.ti.com/clocks
Interface	interface.ti.com
Logic	logic.ti.com
Power Mgmt	power.ti.com
Microcontrollers	microcontroller.ti.com
RFID	www.ti-rfid.com
RF/IF and ZigBee® Solutions	www.ti.com/lprf

Applications

Audio	www.ti.com/audio
Automotive	www.ti.com/automotive
Broadband	www.ti.com/broadband
Digital Control	www.ti.com/digitalcontrol
Medical	www.ti.com/medical
Military	www.ti.com/military
Optical Networking	www.ti.com/opticalnetwork
Security	www.ti.com/security
Telephony	www.ti.com/telephony
Video & Imaging	www.ti.com/video
Wireless	www.ti.com/wireless

Mailing Address: Texas Instruments, Post Office Box 655303, Dallas, Texas 75265
Copyright © 2009, Texas Instruments Incorporated

Looking for pricing, stock, or lifecycle information?

Click below to explore more details on WIN SOURCE:

 [View SN74LS697N on WIN SOURCE](#)

 [Texas Instruments](#) Information

Optimize Your Supply Chain with WIN SOURCE Solutions

-  Global Sourcing Solution
-  Obsolete Management
-  Cost Control Management
-  Shortage Management
-  Alternative Solution
-  Excess Inventory Management