

NCP6132A, NCP6132B

Product Preview

Dual Output 3 Phase & 2 Phase Controller with Single SVID Interface for Desktop and Notebook CPU Applications

The NCP6132A/NCP6132B dual output three plus two phase buck solution is optimized for Intel IMVP-7 and VR12 compatible CPUs. The controller combines true differential voltage sensing, differential inductor DCR current sensing, input voltage feed-forward, and adaptive voltage positioning to provide accurately regulated power for both Desktop and Notebook applications. The control system is based on Dual-Edge pulse-width modulation (PWM) combined with DCR current sensing providing the fastest initial response to dynamic load events and reduced system cost. It also sheds to single phase during light load operation and can auto frequency scale in light load while maintaining excellent transient performance.

There are three internal MOSFET drivers inside the chip. One of these three integrated driver can be configured either to drive core phase or aux phase. NCP6132A and NCP6132B have almost same structure except that NCP6132A has two integrated drivers for the core rail and one integrated driver for auxiliary rail, while the NCP6132B has all three integrated drivers for the core rail.

Features

- Meets Intel's VR12/IMVP7 Specifications
- Three Phase CPU Voltage Regulator, and Two Phase Auxiliary Voltage Regulator, with Three Internal MOSFET Drivers in Total
- Current Mode Dual Edge Modulation for Fastest Initial Response to Transient Loading
- Dual High Performance Operational Error Amplifier
- One Digital Soft Start Ramp for Both Rails
- Dynamic Reference Injection
- Accurate Total Summing Current Amplifier
- DAC with Droop Feed-forward Injection
- Dual High Impedance Differential Voltage and Total Current Sense Amplifiers
- Phase-to-Phase Dynamic Current Balancing
- "Lossless" DCR Current Sensing for Current Balancing
- Summed Thermally Compensated Inductor Current Sensing for Droop
- True Differential Current Balancing Sense Amplifiers for Each Phase

This document contains information on a product under development. ON Semiconductor reserves the right to change or discontinue this product without notice.



ON Semiconductor®

<http://onsemi.com>

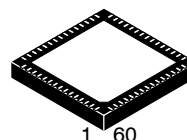

QFN60
CASE 485BB

- x = A or B
- A = Assembly Location
- WL = Wafer Lot
- YY = Year
- WW = Work Week
- G = Pb-Free Package

MARKING DIAGRAM

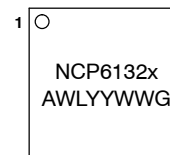

ORDERING INFORMATION

Device	Package	Shipping†
NCP6132AMNR2G	QFN60	2500/Tape
NCP6132BMNR2G	(Pb-Free)	& Reel

†For information on tape and reel specifications, including part orientation and tape sizes, please refer to our Tape and Reel Packaging Specification Brochure, BRD8011/D.

- Adaptive Voltage Positioning (AVP)
- Vin Feed Forward Ramp Slope
- Pin Programming for Internal SVID Parameters
- Over Voltage Protection (OVP) & Under Voltage Protection (UVP)
- Over Current Protection (OCP)
- Dual Power Good Output with Internal Delays
- Pb-free and Halide-free Packages are Available

Applications

- Desktop & Notebook Processors

NCP6132A, NCP6132B

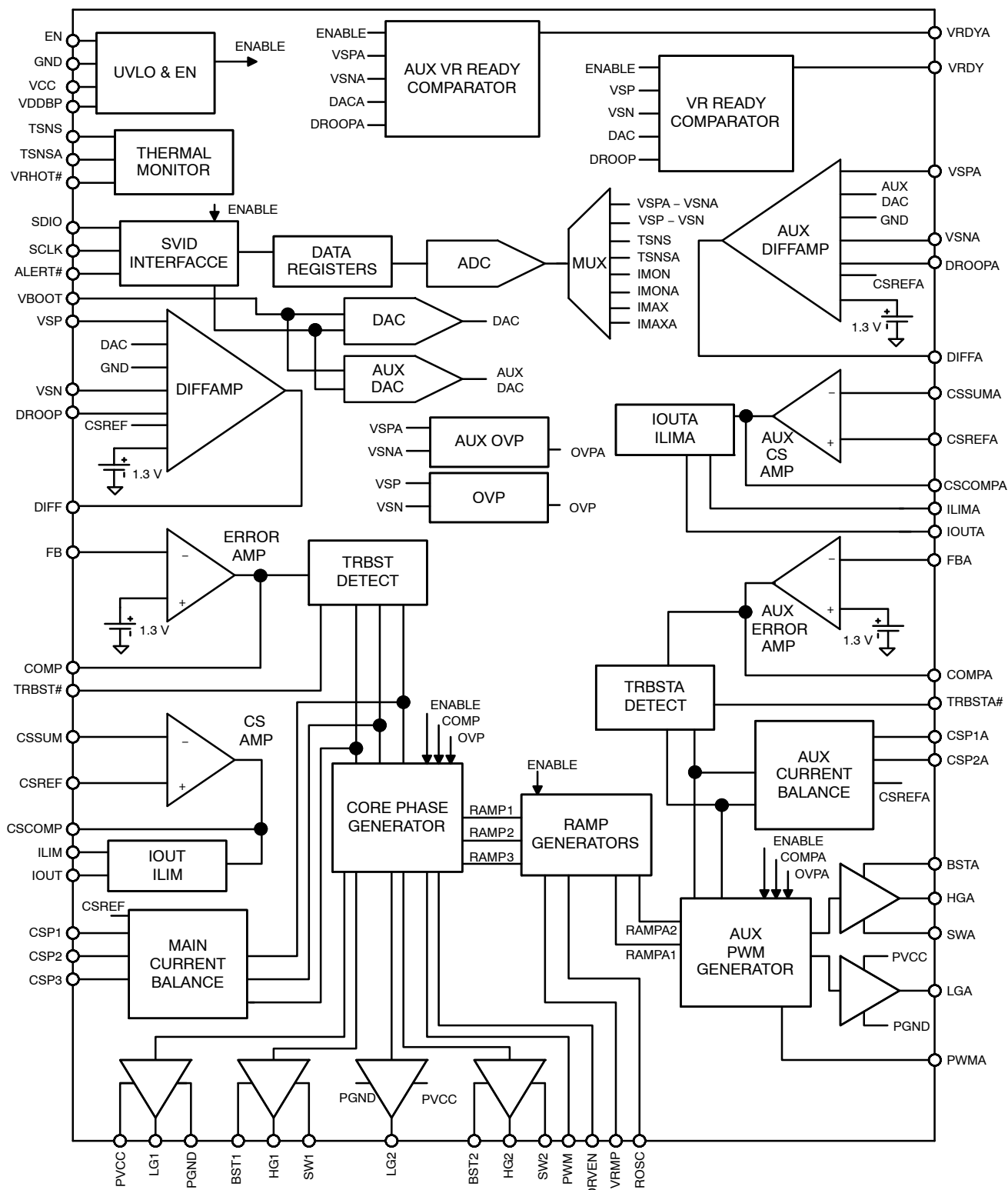

Figure 1. Block Diagram

NCP6132A, NCP6132B

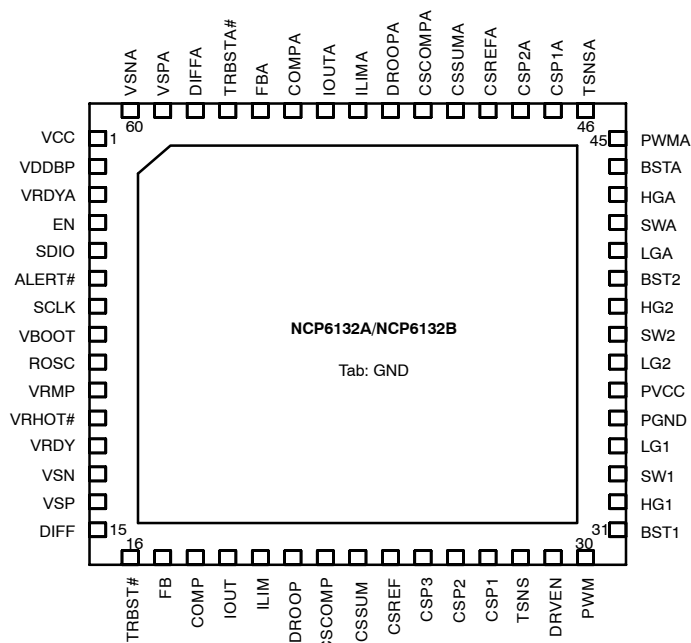

Figure 2. QFN60 Pin Diagram

Table 1. QFN60 PIN LIST DESCRIPTION

Pin No.	Symbol	Description
1	VCC	Power for the internal control circuits. A decoupling capacitor is connected from this pin to ground.
2	VDDBP	Digital Logic power. Connect this pin to VCC with 10 Ω. Connect 0.1 μF capacitor from this pin to ground
3	VRDYA	Open drain output. High indicates that the aux output is regulating.
4	EN	Logic input. Logic high enables both outputs and logic low disables both outputs.
5	SDIO	Serial VID data interface.
6	ALERT#	Serial VID ALERT#.
7	SCLK	Serial VID clock.
8	VBOOT	A resistor to GND on this pin sets the Core and Aux Boot-up Voltage
9	ROSC	A resistance from this pin to ground programs the oscillator frequency. This pin supplies a trimmed output voltage of 2 V.
10	VRMP	Feed-forward input of Vin for the ramp slope compensation. The current fed into this pin is used to control of the ramp of PWM slope
11	VRHOT#	Thermal logic output for over temperature.
12	VRDY	Open drain output. High indicates that the core output is regulating.
13	VSN	Inverting input to the core differential remote sense amplifier.
14	VSP	Non-inverting input to the core differential remote sense amplifier.
15	DIFF	Output of the core differential remote sense amplifier.
16	TRBST#	Compensation pin for the load transient boost.
17	FB	Error amplifier voltage feedback for core output
18	COMP	Output of the error amplifier and the inverting inputs of the PWM comparators for the core output.
19	IOUT	Total output current monitor for core output. Short it to GND if IMON function is not needed.
20	ILIM	Over current shutdown threshold setting for core output. Resistor to CSCOMP to set threshold.
21	DROOP	Used to program droop function for core output. It's connected to the resistor divider placed between CSCOMP and CSREF summing node.
22	CSCOMP	Output of total current sense amplifier for core output.

NCP6132A, NCP6132B

Table 1. QFN60 PIN LIST DESCRIPTION

Pin No.	Symbol	Description
23	CSSUM	Inverting input of total current sense amplifier for core output.
24	CSREF	Total output current sense amplifier reference voltage input. And inverting input to core current balance sense amplifiers.
25	CSP3	Non-inverting input to current balance sense amplifier for phase 3
26	CSP2	Non-inverting input to current balance sense amplifier for phase 2
27	CSP1	Non-inverting input to current balance sense amplifier for phase 1
28	TSNS	Temp Sense input for the core converter.
29	DRVEN	Bidirectional gate driver enable for external drivers for both core and aux rails. It should be left floating if unused.
30	PWM	Phase 3 PWM output. A resistor to ground on this pin programs IMAX.
31	BST1	High-Side Bootstrap supply for phase 1
32	HG1	High-Side gate drive output for phase 1
33	SW1	Current return for high-side gate drive for phase 1
34	LG1	Low-Side gate drive output for phase 1
35	PGND	Power ground for gate drivers
36	PVCC	Power Supply for gate drivers
37	LG2	Low-Side gate drive output for phase 2
38	SW2	Current return for high-side gate drive for phase 2
39	HG2	High-Side gate drive output for phase 2
40	BST2	High-Side Bootstrap supply for phase 2
41	LGA	Low-Side gate drive output for aux phase 1
42	SWA	Current return for high-side gate drive for aux phase 1
43	HGA	High-Side gate drive output for aux phase 1
44	BSTA	High-Side Bootstrap supply for aux phase 1
45	PWMA	Aux Phase 2 PWM output. A resistor to ground on this pin programs IMAXA.
46	TSNSA	Temp sense for the aux converter
47	CSP1A	Non-inverting input to aux current balance sense amplifier for phase 1
48	CSP2A	Non-inverting input to aux current balance sense amplifier for phase 2
49	CSREFA	Total output current sense amplifier reference voltage input for aux. Inverting input to aux current balance sense amplifier for phase 1 and 2
50	CSSUMA	Inverting input of total current sense amplifier for aux output
51	CSCOMPA	Output of total current sense amplifier for aux output
52	DROOPA	Used to program droop function for aux output. It's connected to the resistor divider placed between CSCOMPA and CSREFA.
53	ILMA	Over current shutdown threshold setting for aux output. Resistor to CSCOMPA to set threshold.
54	IOUTA	Total output current monitor for aux output. Short to GND if IMON function is not needed.
55	COMPA	Output of aux error amplifier and inverting input of PWM comparator for aux output
56	FBA	Error amplifier voltage feedback for aux output
57	TRBSTA#	Compensation pin for load transient boost
58	DIFFA	Output of the aux differential remote sense amplifier
59	VSPA	Non-inverting input to aux differential remote sense amplifier
60	VSNA	Inverting input to aux differential remote sense amplifier
61	GND	Analog ground

NCP6132A, NCP6132B

ABSOLUTE MAXIMUM RATINGS

Table 2. ELECTRICAL INFORMATION

Pin Symbol	V _{MAX}	V _{MIN}	I _{SOURCE}	I _{SINK}
COMP, COMPA	V _{CC} + 0.3 V	-0.3 V	2 mA	2 mA
CSCOMP, CSCOMPA	V _{CC} + 0.3 V	-0.3 V	2 mA	2 mA
VSN, VSNA	GND + 300 mV	GND - 300 mV	1 mA	1 mA
DIFF, DIFFA	V _{CC} + 0.3 V	-0.3 V	2 mA	2 mA
VRDY, VRDYA	V _{CC} + 0.3 V	-0.3 V	N/A	2 mA
VDDPB, VCC, PVCC	6.5 V	-0.3 V	N/A	N/A
ROSC	V _{CC} + 0.3 V	-0.3 V	1 mA	N/A
IOUT, IOUTA Output	TBD	-0.3 V		
VRMP	+25 V	-0.3 V		
SW1, SW2, SWA	28 V	-5 V -10 V ≤ 200 ns		
BST1, BST2, BSTA	34 V wrt/ GND 6.5 V wrt/ SW	-0.3 V wrt/ SW		
LG1, LG2, LGA	V _{CC} + 0.3 V	-0.3 V -5 V ≤ 200 ns		
HG1, HG2, HGA	BST + 0.3 V	-0.3 V wrt/ SW -2 V ≤ 200 ns wrt/ SW		
All Other Pins	V _{CC} + 0.3 V	-0.3 V		

Stresses exceeding Maximum Ratings may damage the device. Maximum Ratings are stress ratings only. Functional operation above the Recommended Operating Conditions is not implied. Extended exposure to stresses above the Recommended Operating Conditions may affect device reliability.

*All signals referenced to GND unless noted otherwise.

Table 3. THERMAL INFORMATION

Parameters	Symbol	Typical	Units
Thermal Characteristic QFN Package (Note 1)	R _{JA}	31	°C/W
Operating Junction Temperature Range (Note 2)	T _J	-10 to +125	°C
Operating Ambient Temperature Range		-10 to +100	°C
Maximum Storage Temperature Range	T _{STG}	-40 to +150	°C
Moisture Sensitivity Level QFN Package	MSL	1	

*The maximum package power dissipation must be observed.

1. JESD 51-5 (1S2P Direct-Attach Method) with 0 LFM
2. JESD 51-7 (1S2P Direct-Attach Method) with 0 LFM

NCP6132A, NCP6132B

Table 4. NCP6132A/NCP6132B (3+2) ELECTRICAL CHARACTERISTICS

Unless otherwise stated: $-10^{\circ}\text{C} < T_A < 100^{\circ}\text{C}$; $V_{CC} = 5.0\text{ V}$; $C_{VCC} = 0.1\ \mu\text{F}$

Parameter	Test Conditions	Min	Typ	Max	Units
ERROR AMPLIFIER					
Input Bias Current		-400		400	nA
Open Loop DC Gain	$C_L = 20\ \text{pF to GND}$, $R_L = 10\ \text{k}\Omega\ \text{to GND}$		80		dB
Open Loop Unity Gain Bandwidth	$C_L = 20\ \text{pF to GND}$, $R_L = 10\ \text{k}\Omega\ \text{to GND}$		55		MHz
Slew Rate	$\Delta V_{in} = 100\ \text{mV}$, $G = -10\ \text{V/V}$, $\Delta V_{out} = 1.5\ \text{V} - 2.5\ \text{V}$, $C_L = 20\ \text{pF to GND}$, DC Load = 10k to GND		20		V/ μs
Maximum Output Voltage	$I_{SOURCE} = 2.0\ \text{mA}$	3.5	-	-	V
Minimum Output Voltage	$I_{SINK} = 2.0\ \text{mA}$	-	-	1	V
DIFFERENTIAL SUMMING AMPLIFIER					
Input Bias Current		-400	-	400	nA
VSP Input Voltage Range		-0.3	-	3.0	V
VSN Input Voltage Range		-0.3	-	0.3	V
-3 dB Bandwidth	$C_L = 20\ \text{pF to GND}$, $R_L = 10\ \text{k}\Omega\ \text{to GND}$		12		MHz
Closed Loop DC gain VS to DIFF	$VS+ \text{ to } VS- = 0.5 \text{ to } 1.3\ \text{V}$		1.0		V/V
Droop Accuracy	$CSREF - DROOP = 80\ \text{mV}$ $DAC = 0.8\ \text{V to } 1.2\ \text{V}$ $-10^{\circ}\text{C} \sim 100^{\circ}\text{C}$ $-10^{\circ}\text{C} \sim 85^{\circ}\text{C}$	78.5 79		81.5 81	mV
Maximum Output Voltage	$I_{SOURCE} = 2\ \text{mA}$	3.0	-	-	V
Minimum Output Voltage	$I_{SINK} = 2\ \text{mA}$	-	-	0.5	V

3. Guaranteed by design/characterization, not in production test
4. Guaranteed by characterization

NCP6132A, NCP6132B

Table 5. ELECTRICAL CHARACTERISTICS Unless otherwise stated: $-10^{\circ}\text{C} < T_A < 100^{\circ}\text{C}$; $V_{CC} = 5.0\text{ V}$; $C_{VCC} = 0.1\ \mu\text{F}$

Parameter	Test Conditions	Min	Typ	Max	Units
CURRENT SUMMING AMPLIFIER					
Offset Voltage (V_{os})		-300		300	μV
Input Bias Current (CSSUM)	CSSUM = CSREF = 1 V	-7.5		7.5	nA
Open Loop Gain			80		dB
Current Sense Unity Gain Bandwidth	$C_L = 20\ \text{pF}$ to GND, $R_L = 10\ \text{k}\Omega$ to GND		10		MHz
Maximum CSCOMP (A) Output Voltage	$I_{source} = 2\ \text{mA}$	3.5	-	-	V
Minimum CSCOMP(A) Output Voltage	$I_{sink} = 500\ \mu\text{A}$	-	-	0.1	V
CURRENT BALANCE AMPLIFIER					
Input Bias Current	CSPx = CSREF = 1.2 V	-50	-	50	nA
Common Mode Input Voltage Range	CSPx = CSREF	0	-	2.0	V
Differential Mode Input Voltage Range	CSREF = 1.2 V	-100	-	100	mV
Input Offset Voltage Matching	CSPx = CSREF = 1.2 V, Measured from the average	-1.5	-	1.5	mV
Current Sense Amplifier Gain	$0\ \text{V} < \text{CSPx} - \text{CSREF} < 0.1\ \text{V}$, -10°C ~ 85°C -10°C ~ 100°C	5.7 5.5	6.0 6.0	6.3 6.3	V/V
Multiphase Current Sense Gain Matching	CSREF = CSP = 10 mV to 30 mV	-3		3	%
-3 dB Bandwidth			8		MHz
BIAS SUPPLY					
V_{CC} Quiescent Current	EN = high	20	27	35	mA
	EN = low		10	70	μA
UVLO Threshold	V_{CC} rising			4.5	V
	V_{CC} falling	4.0			V
VCC UVLO Hysteresis			200		mV
VDDBP Quiescent Current	EN = Low EN = High		0.8 12.0		mA
DAC SLEW RATE					
Soft Start Slew Rate			2.33		$\text{mV}/\mu\text{s}$
Slew Rate Slow			3.5		$\text{mV}/\mu\text{s}$
Slew Rate Fast			13.5		$\text{mV}/\mu\text{s}$
AUX Soft Start Slew Rate			2.33		$\text{mV}/\mu\text{s}$
AUX Slew Rate Slow			3.5		$\text{mV}/\mu\text{s}$
AUX Slew Rate Fast			13.5		$\text{mV}/\mu\text{s}$
ENABLE INPUT					
Enable High Input Leakage Current	External 1k pull-up to 3.3 V	-		1.0	μA
Upper Threshold	V_{UPPER}	0.8			V
Lower Threshold	V_{LOWER}			0.35	V
Total Hysteresis	$V_{UPPER} - V_{LOWER}$		95		mV
Enable Delay Time	Measure time from Enable transitioning HI to when DRON goes high, V_{boot} is not 0 V			5.0	ms

3. Guaranteed by design/characterization, not in production test

4. Guaranteed by characterization

NCP6132A, NCP6132B

Table 5. ELECTRICAL CHARACTERISTICS Unless otherwise stated: $-10^{\circ}\text{C} < T_A < 100^{\circ}\text{C}$; $V_{CC} = 5.0\text{ V}$; $C_{VCC} = 0.1\ \mu\text{F}$

Parameter	Test Conditions	Min	Typ	Max	Units
DRVEN					
Output High Voltage	Sourcing 500 μA	3.5			V
Output Low Voltage	Sinking 500 μA			0.1	V
Rise Time	CL (PCB) = 20 pF, $\Delta V_o = 10\%$ to 90%	-	255	-	ns
Fall Time		-	2	-	ns
Internal Pull Down Resistance	EN = Low		70		k Ω
IOUT / IOUTA OUTPUT					
Maximum Output Voltage	$R_{lim} = 5\text{k}$	2.5			V
Input Referred Offset Voltage	I_{limit} to CSREF	-2.5		2.5	mV
Output Source Current	I_{limit} sink current = 80 μA			840	μA
Current Gain	$(I_{OUTCURRENT}) / (I_{LIMCURRENT})$, $R_{ILIM} = R_{OUT} = 8.0\ \text{k}\Omega$, Temp range: 0°C to 60°C	9.5	10	10.5	
OSCILLATOR					
Switching Frequency Range		200	-	800	kHz
Switching Frequency Accuracy	$200\ \text{kHz} < F_{sw} < 800\ \text{kHz}$	-10	-	10	%
3 Phase Operation	$R_{osc} = 67.4\ \text{k}\Omega$	360	400	440	kHz
Rosc Output Voltage	$R_{osc} = 67.4\ \text{k}\Omega$	1.95	2.00	2.05	V
OUTPUT OVER VOLTAGE & UNDER VOLTAGE PROTECTION (OVP & UVP)					
Over Voltage Threshold During Soft-Start & DVID		1.7	1.75	1.8	V
Over Voltage Threshold Above DAC	VSP(A) Rising	225	250	275	mV
Over Voltage Delay	VSP(A) rising to PWMx low		50		ns
Under Voltage Threshold Below DAC-DROOP	VSP(A) Falling	350	400	450	mV
Under-voltage Hysteresis	VSP(A) Rising		25		mV
Under-voltage Delay			5		μs
VR12 DAC					
System Voltage Accuracy	$-10^{\circ}\text{C} \sim 85^{\circ}\text{C}$ 1.0 V \leq DAC < 1.52 V 0.8 V < DAC < 0.995 V 0.5 V < DAC < 0.795 V 0.25 V < DAC < 0.495 V $-10^{\circ}\text{C} \sim 100^{\circ}\text{C}$ 1.0 V \leq DAC < 1.52 V 0.8 V < DAC < 0.995 V 0.5 V < DAC < 0.795 V 0.25 V < DAC < 0.495 V	-0.5 -5 -8 -8		+0.5 +5 +8 +8	% mV mV mV
Droop Feed-Forward Current	Measure on DROOP pin	60	66	72	μA
Droop Feed-Forward Pulse On-Time			0.16		μs
OVERCURRENT PROTECTION					
ILIM Threshold Current (OCP shutdown after 50 μs delay)	Aux/Core Multiphase, PS0, $R_{lim} = 20\ \text{k}\Omega$	9.0	10	11.0	μA
	Aux/Core 1-phase, PS1/2/3, $R_{lim} = 20\ \text{k}\Omega$		10		μA
	Aux 2-phase, PS1, $R_{lim} = 20\ \text{k}\Omega$		10		μA
	Core 2-phase, PS1, $R_{lim} = 20\ \text{k}\Omega$		6.5		μA
	Aux/Core 2-phase, PS2/3, $R_{lim} = 20\ \text{k}\Omega$		6.5		μA
	Core 3-phase, PS1/2/3, $R_{lim} = 20\ \text{k}\Omega$		4.0		μA

3. Guaranteed by design/characterization, not in production test

4. Guaranteed by characterization

NCP6132A, NCP6132B

Table 5. ELECTRICAL CHARACTERISTICS Unless otherwise stated: $-10^{\circ}\text{C} < T_A < 100^{\circ}\text{C}$; $V_{CC} = 5.0\text{ V}$; $C_{VCC} = 0.1\ \mu\text{F}$

Parameter	Test Conditions	Min	Typ	Max	Units
OVERCURRENT PROTECTION					
ILIM Threshold Current (immediate OCP shutdown)	Aux/Core Multiphase, PS0, $R_{lim} = 20\ \text{k}\Omega$	13.5	15	16.5	μA
	Aux/Core 1-phase, PS1/2/3, $R_{lim} = 20\ \text{k}\Omega$		15		μA
	Aux 2-phase, PS1, $R_{lim} = 20\ \text{k}\Omega$		15		μA
	Core 2-phase, PS1, $R_{lim} = 20\ \text{k}\Omega$		10		μA
	Aux/Core 2-phase, PS2/3, $R_{lim} = 20\ \text{k}\Omega$		10		μA
	Core 3-phase, PS1/2/3, $R_{lim} = 20\ \text{k}\Omega$		6		μA
MODULATORS (PWM COMPARATORS) FOR CORE & AUX					
Minimum Pulse Width	$F_{sw} = 350\ \text{kHz}$		60		ns
0% Duty Cycle	COMP voltage when the PWM outputs remain LO		1.3	-	V
100% Duty Cycle	COMP voltage when the PWM outputs remain HI $V_{RMP} = 12.0\ \text{V}$	-	2.5	-	V
PWM Ramp Duty Cycle Matching	COMP = 2 V, PWM Ton matching	-20		20	%
PWM Phase Angle Error	Between adjacent phases	-25		25	deg
Ramp Feed-forward Voltage range		5		22	V
TRBST#					
TRBST/COMP offset	TRBST Starts Sinking Current		350		mV
TRBST Sink Capability			500		μA
TRBSTA#					
TRBSTA/COMP offset	TRBSTA Starts Sinking Current		350		mV
TRBSTA Sink Capability			500		μA
VRHOT#					
Output Low Voltage	$I_{VRHOT} = -4\ \text{mA}$			0.3	V
Output Leakage Current	High Impedance State	-1.0	-	1.0	μA
TSNS/TSNSA					
Alert# Assert Threshold			515		mV
Alert# De-assert Threshold			533		mV
VRHOT# Assert Threshold			496		mV
VRHOT# Rising Threshold			515		mV
TSNS Bias Current		115	120	125	μA
ADC					
Voltage Range		0		2	V
Total Unadjusted Error (TUE)		-1		+1	%
Differential Nonlinearity (DNL)	8-bit			1	LSB
Power Supply Sensitivity			+/-1		%
Conversion Time			30		μs
Round Robin			90		μs
VRDY, VRDYA (Power Good) OUTPUT					
Output Low Saturation Voltage	$I_{VRDY(A)} = 4\ \text{mA}$	-	-	0.3	V

3. Guaranteed by design/characterization, not in production test
4. Guaranteed by characterization

NCP6132A, NCP6132B

Table 5. ELECTRICAL CHARACTERISTICS Unless otherwise stated: $-10^{\circ}\text{C} < T_A < 100^{\circ}\text{C}$; $V_{CC} = 5.0\text{ V}$; $C_{VCC} = 0.1\ \mu\text{F}$

Parameter	Test Conditions	Min	Typ	Max	Units
VRDY, VRDYA (Power Good) OUTPUT					
Rise Time	External pull-up of 1 k Ω to 3.3 V, $C_{TOT} = 45\ \text{pF}$, $\Delta V_o = 10\%$ to 90%	–	100		ns
Fall Time	External pull-up of 1 k Ω to 3.3 V, $C_{TOT} = 45\ \text{pF}$, $\Delta V_o = 90\%$ to 10%		10		ns
Output Voltage at Power-up	VRDY, VRDYA pulled up to 5 V via 2 k Ω	–	–	1.0	V
Output Leakage Current When High	VRDY & VRDYA = 5.0 V	–1.0	–	1.0	μA
VRDY Delay (rising)	DAC = TARGET to VRDY		500		μs
VRDY Delay (falling)	From OCP or OVP	–	5	–	μs
PWM, PWMA OUTPUTS					
Output High Voltage	Sourcing 500 μA	$V_{CC} - 1.0\ \text{V}$	–	–	V
Output Mid Voltage	No Load, SetPS = 02	1.3	2.0	2.7	V
Output Low Voltage	Sinking 500 μA	–	–	0.7	V
Rise and Fall Time	CL (PCB) = 50 pF, $\Delta V_o = \text{GND to VCC}$	–	10		ns
Tri-State Output Leakage	Gx = 2.0 V, x = 1–4, EN = Low	–1.0	–	1.0	μA
PHASE DETECTION					
CSP1A, CSP2A, CSP2, CSP3 Pin Threshold Voltage		4.2			V
SCLK, SDIO					
V_{IL}	Input Low Voltage			0.45	V
V_{IH}	Input High Voltage	0.65			V
V_{HYS}	Hysteresis Voltage	50			mV
V_{OH}	Output High Voltage		1.05		V
V_{OL}	Output Low Voltage (SDIO only)		TBD		mV
R_{ON}	Buffer On Resistance (data line, ALERT#, and VRHOT#)	4		13	Ω
Leakage Current		–100		100	μA
Pad Capacitance (Note 3)				4.0	pF
VR clock to data delay (Tco) (Note 3)		4		8.3	ns
Setup time (Tsu) (Note 3)		7			ns
Hold time (Thld) (Note 3)		14			ns
HIGH-SIDE MOSFET DRIVER					
Pull-up Resistance, Sourcing Current (Note 4)	BST = PVCC		1.2	2.0	Ω
High Side Driver Sourcing Current	BST = PVCC		4.17		A
Pull-down Resistance, Sinking Current (Note 4)	BST = PVCC		0.8	2.0	Ω
High Side Driver Sinking Current	BST = PVCC		6.25		A
HG1, HG2, HGA Rise Time	$V_{CC} = 5\ \text{V}$, 3 nF load, BST – SW = 5 V	6	16	30	ns
HG1, HG2, HGA Fall Time	$V_{CC} = 5\ \text{V}$, 3 nF load, BST – SW = 5 V	6	11	30	ns
HG1, HG2, HGA Turn-On Propagation Delay tp_{dHDRVH}	$C_{LOAD} = 3\ \text{nF}$	16	40	47	ns
SW1, SW2, SWA Pull-Down Resistance	SW to PGND		2		k Ω

3. Guaranteed by design/characterization, not in production test

4. Guaranteed by characterization

NCP6132A, NCP6132B

Table 5. ELECTRICAL CHARACTERISTICS Unless otherwise stated: $-10^{\circ}\text{C} < T_A < 100^{\circ}\text{C}$; $V_{CC} = 5.0\text{ V}$; $C_{VCC} = 0.1\ \mu\text{F}$

Parameter	Test Conditions	Min	Typ	Max	Units
HIGH-SIDE MOSFET DRIVER					
HG1, HG2, HGA Pull-Down Resistance	HG to SWBST-SW = 0 V		260		k Ω
BST Quiescent Current	EN = L (shutdown) EN = H, no switching		1.0 300	10	μA
LOW-SIDE MOSFET DRIVER					
Pull-up Resistance, Sourcing Current (Note 4)			0.9	2.0	Ω
Low Side Driver Sourcing Current			5.56		A
Pull-down Resistance, Sinking Current (Note 4)			0.4	1.0	Ω
Low Side Driver Sinking Current			12.5		A
LG1, LG2, LGA Rise Time	3 nF load	6	16	30	ns
LG1, LG2, LGA Fall Time	3 nF load	6	11	30	ns
LG1, LG2, LGA Turn-On Propagation Delay $t_{pdh_{DRVL}}$	$C_{LOAD} = 3\text{ nF}$		11	30	ns
LG1, LG2, LGA Pull-Down Resistance	LG to PGND, $V_{CC} = 5\text{ V}$		45		k Ω
PVCC Quiescent Current	EN = L (Shutdown) EN = H, no switching		1.0 490	10	μA
BOOTSTRAP RECTIFIER SWITCH					
On Resistance	EN = L or EN = H and DRVL = H	5.0	9.0	14.0	Ω

3. Guaranteed by design/characterization, not in production test
4. Guaranteed by characterization

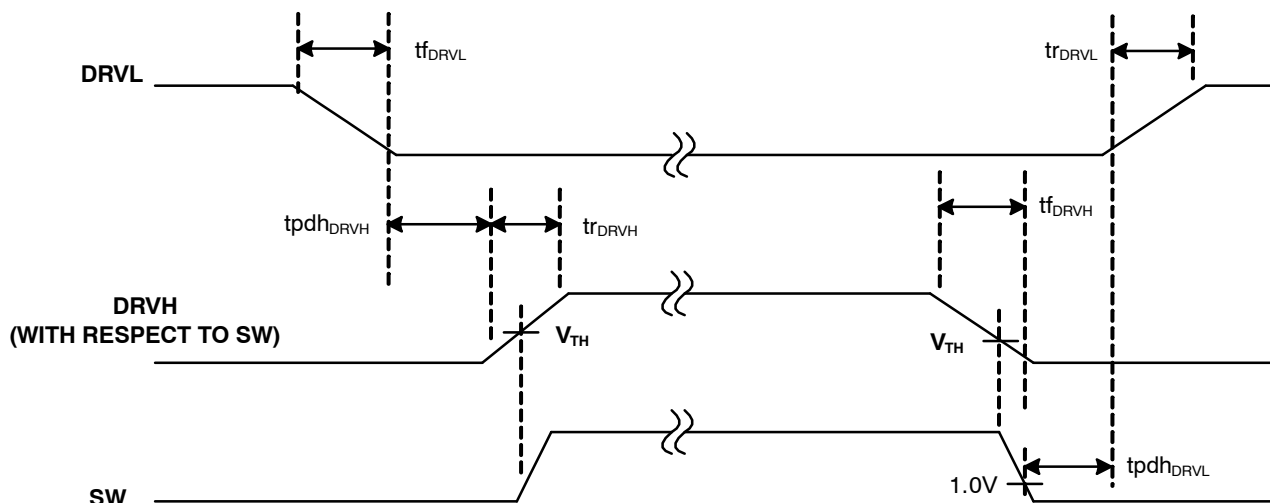

Figure 3. Timing Diagram

NOTE: Timing is referenced to the 90% and 10% points, unless otherwise noted.

NCP6132A, NCP6132B

Table 6. VR12, IMVP-7 VID CODES

VID7	VID6	VID5	VID4	VID3	VID2	VID1	VID0	Voltage (V)	HEX
0	0	0	0	0	0	0	0	OFF	00
0	0	0	0	0	0	0	1	0.25000	01
0	0	0	0	0	0	1	0	0.25500	02
0	0	0	0	0	0	1	1	0.26000	03
0	0	0	0	0	1	0	0	0.26500	04
0	0	0	0	0	1	0	1	0.27000	05
0	0	0	0	0	1	1	0	0.27500	06
0	0	0	0	0	1	1	1	0.28000	07
0	0	0	0	1	0	0	0	0.28500	08
0	0	0	0	1	0	0	1	0.29000	09
0	0	0	0	1	0	1	0	0.29500	0A
0	0	0	0	1	0	1	1	0.30000	0B
0	0	0	0	1	1	0	0	0.30500	0C
0	0	0	0	1	1	0	1	0.31000	0D
0	0	0	0	1	1	1	0	0.31500	0E
0	0	0	0	1	1	1	1	0.32000	0F
0	0	0	1	0	0	0	0	0.32500	10
0	0	0	1	0	0	0	1	0.33000	11
0	0	0	1	0	0	1	0	0.33500	12
0	0	0	1	0	0	1	1	0.34000	13
0	0	0	1	0	1	0	0	0.34500	14
0	0	0	1	0	1	0	1	0.35000	15
0	0	0	1	0	1	1	0	0.35500	16
0	0	0	1	0	1	1	1	0.36000	17
0	0	0	1	1	0	0	0	0.36500	18
0	0	0	1	1	0	0	1	0.37000	19
0	0	0	1	1	0	1	0	0.37500	1A
0	0	0	1	1	0	1	1	0.38000	1B
0	0	0	1	1	1	0	0	0.38500	1C
0	0	0	1	1	1	0	1	0.39000	1D
0	0	0	1	1	1	1	0	0.39500	1E
0	0	0	1	1	1	1	1	0.40000	1F
0	0	1	0	0	0	0	0	0.40500	20
0	0	1	0	0	0	0	1	0.41000	21
0	0	1	0	0	0	1	0	0.41500	22
0	0	1	0	0	0	1	1	0.42000	23
0	0	1	0	0	1	0	0	0.42500	24
0	0	1	0	0	1	0	1	0.43000	25
0	0	1	0	0	1	1	0	0.43500	26
0	0	1	0	0	1	1	1	0.44000	27
0	0	1	0	1	0	0	0	0.44500	28
0	0	1	0	1	0	0	1	0.45000	29
0	0	1	0	1	0	1	0	0.45500	2A

NCP6132A, NCP6132B

Table 6. VR12, IMVP-7 VID CODES

VID7	VID6	VID5	VID4	VID3	VID2	VID1	VID0	Voltage (V)	HEX
0	0	1	0	1	0	1	1	0.46000	2B
0	0	1	0	1	1	0	0	0.46500	2C
0	0	1	0	1	1	0	1	0.47000	2D
0	0	1	0	1	1	1	0	0.47500	2E
0	0	1	0	1	1	1	1	0.48000	2F
0	0	1	1	0	0	0	0	0.48500	30
0	0	1	1	0	0	0	1	0.49000	31
0	0	1	1	0	0	1	0	0.49500	32
0	0	1	1	0	0	1	1	0.50000	33
0	0	1	1	0	1	0	0	0.50500	34
0	0	1	1	0	1	0	1	0.51000	35
0	0	1	1	0	1	1	0	0.51500	36
0	0	1	1	0	1	1	1	0.52000	37
0	0	1	1	1	0	0	0	0.52500	38
0	0	1	1	1	0	0	1	0.53000	39
0	0	1	1	1	0	1	0	0.53500	3A
0	0	1	1	1	0	1	1	0.54000	3B
0	0	1	1	1	1	0	0	0.54500	3C
0	0	1	1	1	1	0	1	0.55000	3D
0	0	1	1	1	1	1	0	0.55500	3E
0	0	1	1	1	1	1	1	0.56000	3F
0	1	0	0	0	0	0	0	0.56500	40
0	1	0	0	0	0	0	1	0.57000	41
0	1	0	0	0	0	1	0	0.57500	42
0	1	0	0	0	0	1	1	0.58000	43
0	1	0	0	0	1	0	0	0.58500	44
0	1	0	0	0	1	0	1	0.59000	45
0	1	0	0	0	1	1	0	0.59500	46
0	1	0	0	0	1	1	1	0.60000	47
0	1	0	0	1	0	0	0	0.60500	48
0	1	0	0	1	0	0	1	0.61000	49
0	1	0	0	1	0	1	0	0.61500	4A
0	1	0	0	1	0	1	1	0.62000	4B
0	1	0	0	1	1	0	0	0.62500	4C
0	1	0	0	1	1	0	1	0.63000	4D
0	1	0	0	1	1	1	0	0.63500	4E
0	1	0	0	1	1	1	1	0.64000	4F
0	1	0	1	0	0	0	0	0.64500	50
0	1	0	1	0	0	0	1	0.65000	51
0	1	0	1	0	0	1	0	0.65500	52
0	1	0	1	0	0	1	1	0.66000	53
0	1	0	1	0	1	0	0	0.66500	54
0	1	0	1	0	1	0	1	0.67000	55

NCP6132A, NCP6132B

Table 6. VR12, IMVP-7 VID CODES

VID7	VID6	VID5	VID4	VID3	VID2	VID1	VID0	Voltage (V)	HEX
0	1	0	1	0	1	1	0	0.67500	56
0	1	0	1	0	1	1	1	0.68000	57
0	1	0	1	1	0	0	0	0.68500	58
0	1	0	1	1	0	0	1	0.69000	59
0	1	0	1	1	0	1	0	0.69500	5A
0	1	0	1	1	0	1	1	0.70000	5B
0	1	0	1	1	1	0	0	0.70500	5C
0	1	0	1	1	1	0	1	0.71000	5D
0	1	0	1	1	1	1	0	0.71500	5E
0	1	0	1	1	1	1	1	0.72000	5F
0	1	1	0	0	0	0	0	0.72500	60
0	1	1	0	0	0	0	1	0.73000	61
0	1	1	0	0	0	1	0	0.73500	62
0	1	1	0	0	0	1	1	0.74000	63
0	1	1	0	0	1	0	0	0.74500	64
0	1	1	0	0	1	0	1	0.75000	65
0	1	1	0	0	1	1	0	0.75500	66
0	1	1	0	0	1	1	1	0.76000	67
0	1	1	0	1	0	0	0	0.76500	68
0	1	1	0	1	0	0	1	0.77000	69
0	1	1	0	1	0	1	0	0.77500	6A
0	1	1	0	1	0	1	1	0.78000	6B
0	1	1	0	1	1	0	0	0.78500	6C
0	1	1	0	1	1	0	1	0.79000	6D
0	1	1	0	1	1	1	0	0.79500	6E
0	1	1	0	1	1	1	1	0.80000	6F
0	1	1	1	0	0	0	0	0.80500	70
0	1	1	1	0	0	0	1	0.81000	71
0	1	1	1	0	0	1	0	0.81500	72
0	1	1	1	0	0	1	1	0.82000	73
0	1	1	1	0	1	0	0	0.82500	74
0	1	1	1	0	1	0	1	0.83000	75
0	1	1	1	0	1	1	0	0.83500	76
0	1	1	1	0	1	1	1	0.84000	77
0	1	1	1	1	0	0	0	0.84500	78
0	1	1	1	1	0	0	1	0.85000	79
0	1	1	1	1	0	1	0	0.85500	7A
0	1	1	1	1	0	1	1	0.86000	7B
0	1	1	1	1	1	0	0	0.86500	7C
0	1	1	1	1	1	0	1	0.87000	7D
0	1	1	1	1	1	1	0	0.87500	7E
0	1	1	1	1	1	1	1	0.88000	7F
1	0	0	0	0	0	0	0	0.88500	80

NCP6132A, NCP6132B

Table 6. VR12, IMVP-7 VID CODES

VID7	VID6	VID5	VID4	VID3	VID2	VID1	VID0	Voltage (V)	HEX
1	0	0	0	0	0	0	1	0.89000	81
1	0	0	0	0	0	1	0	0.89500	82
1	0	0	0	0	0	1	1	0.90000	83
1	0	0	0	0	1	0	0	0.90500	84
1	0	0	0	0	1	0	1	0.91000	85
1	0	0	0	0	1	1	0	0.91500	86
1	0	0	0	0	1	1	1	0.92000	87
1	0	0	0	1	0	0	0	0.92500	88
1	0	0	0	1	0	0	1	0.93000	89
1	0	0	0	1	0	1	0	0.93500	8A
1	0	0	0	1	0	1	1	0.94000	8B
1	0	0	0	1	1	0	0	0.94500	8C
1	0	0	0	1	1	0	1	0.95000	8D
1	0	0	0	1	1	1	0	0.95500	8E
1	0	0	0	1	1	1	1	0.96000	8F
1	0	0	1	0	0	0	0	0.96500	90
1	0	0	1	0	0	0	1	0.97000	91
1	0	0	1	0	0	1	0	0.97500	92
1	0	0	1	0	0	1	1	0.98000	93
1	0	0	1	0	1	0	0	0.98500	94
1	0	0	1	0	1	0	1	0.99000	95
1	0	0	1	0	1	1	0	0.99500	96
1	0	0	1	0	1	1	1	1.00000	97
1	0	0	1	1	0	0	0	1.00500	98
1	0	0	1	1	0	0	1	1.01000	99
1	0	0	1	1	0	1	0	1.01500	9A
1	0	0	1	1	0	1	1	1.02000	9B
1	0	0	1	1	1	0	0	1.02500	9C
1	0	0	1	1	1	0	1	1.03000	9D
1	0	0	1	1	1	1	0	1.03500	9E
1	0	0	1	1	1	1	1	1.04000	9F
1	0	1	0	0	0	0	0	1.04500	A0
1	0	1	0	0	0	0	1	1.05000	A1
1	0	1	0	0	0	1	0	1.05500	A2
1	0	1	0	0	0	1	1	1.06000	A3
1	0	1	0	0	1	0	0	1.06500	A4
1	0	1	0	0	1	0	1	1.07000	A5
1	0	1	0	0	1	1	0	1.07500	A6
1	0	1	0	0	1	1	1	1.08000	A7
1	0	1	0	1	0	0	0	1.08500	A8
1	0	1	0	1	0	0	1	1.09000	A9
1	0	1	0	1	0	1	0	1.09500	AA
1	0	1	0	1	0	1	1	1.10000	AB

NCP6132A, NCP6132B

Table 6. VR12, IMVP-7 VID CODES

VID7	VID6	VID5	VID4	VID3	VID2	VID1	VID0	Voltage (V)	HEX
1	0	1	0	1	1	0	0	1.10500	AC
1	0	1	0	1	1	0	1	1.11000	AD
1	0	1	0	1	1	1	0	1.11500	AE
1	0	1	0	1	1	1	1	1.12000	AF
1	0	1	1	0	0	0	0	1.12500	B0
1	0	1	1	0	0	0	1	1.13000	B1
1	0	1	1	0	0	1	0	1.13500	B2
1	0	1	1	0	0	1	1	1.14000	B3
1	0	1	1	0	1	0	0	1.14500	B4
1	0	1	1	0	1	0	1	1.15000	B5
1	0	1	1	0	1	1	0	1.15500	B6
1	0	1	1	0	1	1	1	1.16000	B7
1	0	1	1	1	0	0	0	1.16500	B8
1	0	1	1	1	0	0	1	1.17000	B9
1	0	1	1	1	0	1	0	1.17500	BA
1	0	1	1	1	0	1	1	1.18000	BB
1	0	1	1	1	1	0	0	1.18500	BC
1	0	1	1	1	1	0	1	1.19000	BD
1	0	1	1	1	1	1	0	1.19500	BE
1	0	1	1	1	1	1	1	1.20000	BF
1	1	0	0	0	0	0	0	1.20500	C0
1	1	0	0	0	0	0	1	1.21000	C1
1	1	0	0	0	0	1	0	1.21500	C2
1	1	0	0	0	0	1	1	1.22000	C3
1	1	0	0	0	1	0	0	1.22500	C4
1	1	0	0	0	1	0	1	1.23000	C5
1	1	0	0	0	1	1	0	1.23500	C6
1	1	0	0	0	1	1	1	1.24000	C7
1	1	0	0	1	0	0	0	1.24500	C8
1	1	0	0	1	0	0	1	1.25000	C9
1	1	0	0	1	0	1	0	1.25500	CA
1	1	0	0	1	0	1	1	1.26000	CB
1	1	0	0	1	1	0	0	1.26500	CC
1	1	0	0	1	1	0	1	1.27000	CD
1	1	0	0	1	1	1	0	1.27500	CE
1	1	0	0	1	1	1	1	1.28000	CF
1	1	0	1	0	0	0	0	1.28500	D0
1	1	0	1	0	0	0	1	1.29000	D1
1	1	0	1	0	0	1	0	1.29500	D2
1	1	0	1	0	0	1	1	1.30000	D3
1	1	0	1	0	1	0	0	1.30500	D4
1	1	0	1	0	1	0	1	1.31000	D5
1	1	0	1	0	1	1	0	1.31500	D6

NCP6132A, NCP6132B

Table 6. VR12, IMVP-7 VID CODES

VID7	VID6	VID5	VID4	VID3	VID2	VID1	VID0	Voltage (V)	HEX
1	1	0	1	0	1	1	1	1.32000	D7
1	1	0	1	1	0	0	0	1.32500	D8
1	1	0	1	1	0	0	1	1.33000	D9
1	1	0	1	1	0	1	0	1.33500	DA
1	1	0	1	1	0	1	1	1.34000	DB
1	1	0	1	1	1	0	0	1.34500	DC
1	1	0	1	1	1	0	1	1.35000	DD
1	1	0	1	1	1	1	0	1.35500	DE
1	1	0	1	1	1	1	1	1.36000	DF
1	1	1	0	0	0	0	0	1.36500	E0
1	1	1	0	0	0	0	1	1.37000	E1
1	1	1	0	0	0	1	0	1.37500	E2
1	1	1	0	0	0	1	1	1.38000	E3
1	1	1	0	0	1	0	0	1.38500	E4
1	1	1	0	0	1	0	1	1.39000	E5
1	1	1	0	0	1	1	0	1.39500	E6
1	1	1	0	0	1	1	1	1.40000	E7
1	1	1	0	1	0	0	0	1.40500	E8
1	1	1	0	1	0	0	1	1.41000	E9
1	1	1	0	1	0	1	0	1.41500	EA
1	1	1	0	1	0	1	1	1.42000	EB
1	1	1	0	1	1	0	0	1.42500	EC
1	1	1	0	1	1	0	1	1.43000	ED
1	1	1	0	1	1	1	0	1.43500	EE
1	1	1	0	1	1	1	1	1.44000	EF
1	1	1	1	0	0	0	0	1.44500	F0
1	1	1	1	0	0	0	1	1.45000	F1
1	1	1	1	0	0	1	0	1.45500	F2
1	1	1	1	0	0	1	1	1.46000	F3
1	1	1	1	0	1	0	0	1.46500	F4
1	1	1	1	0	1	0	1	1.47000	F5
1	1	1	1	0	1	1	0	1.47500	F6
1	1	1	1	0	1	1	1	1.48000	F7
1	1	1	1	1	0	0	0	1.48500	F8
1	1	1	1	1	0	0	1	1.49000	F9
1	1	1	1	1	0	1	0	1.49500	FA
1	1	1	1	1	0	1	1	1.50000	FB
1	1	1	1	1	1	0	0	1.50500	FC
1	1	1	1	1	1	0	1	1.51000	FD
1	1	1	1	1	1	1	0	1.51500	FE
1	1	1	1	1	1	1	1	1.52000	FF

NCP6132A, NCP6132B

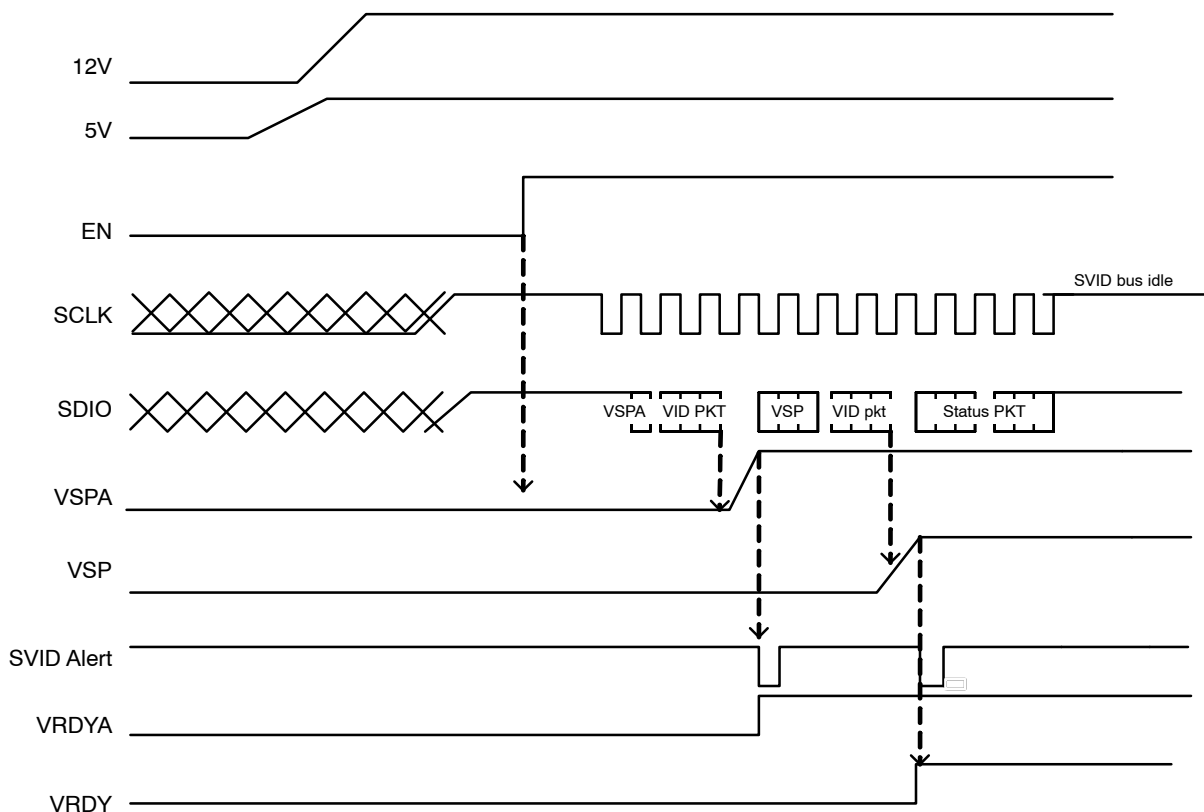

Figure 4. Start Up Timing Diagram

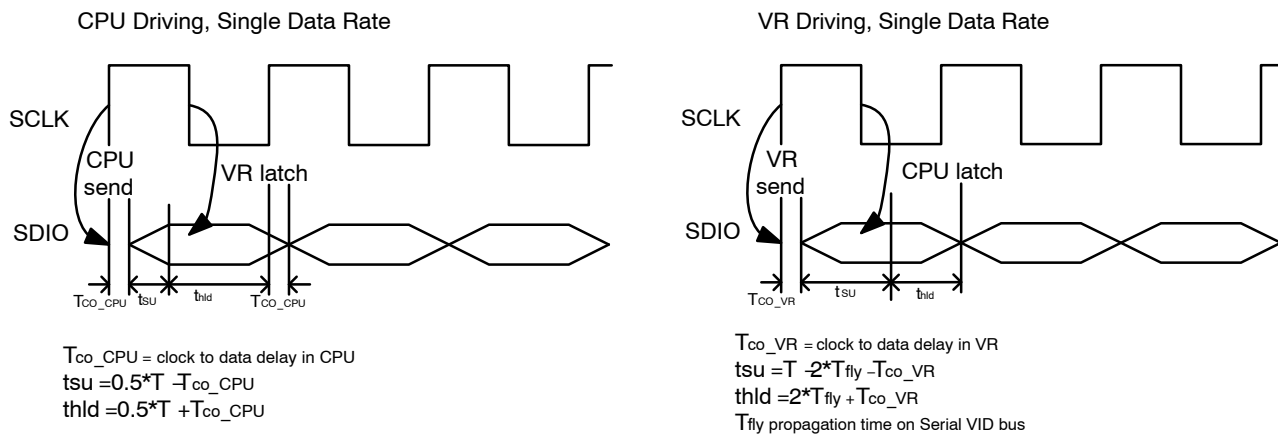

Figure 5. SVID Timing Diagram

NCP6132A, NCP6132B

Table 7. STATE TRUTH TABLE

STATE	VRDY(A) Pin	Error AMP Comp(A) Pin	OVP(A) & UVP(A)	DRVEN PIN	Method of Reset
POR 0 < V _{CC} < UVLO	N/A	N/A	N/A	Resistive pull down	
Disabled EN < threshold UVLO > threshold	Low	Low	Disabled	Low	
Start up Delay & Calibration EN > threshold UVLO > threshold	Low	Low	Disabled	Low	
DRVEN Fault EN > threshold UVLO > threshold DRVEN < threshold	Low	Low	Disabled	Resistive pull up	Driver must release DRVEN to high
Soft Start EN > threshold UVLO > threshold DRVEN > High	Low	Operational	Active / No latch	High	
Normal Operation EN > threshold UVLO > threshold DRVEN > High	High	Operational	Active / Latching	High	N/A
Over Voltage	Low	N/A	DAC + 150 mV	High	
Over Current	Low	Operational	Last DAC Code	Low	
VID Code = 00h	Follows the MultiVR Config register (34h) Bit 0 setting	Low	Disabled	High, PWM/PWMA outputs in low state LGx outputs in high state	Set Valid VID Code

NCP6132A, NCP6132B

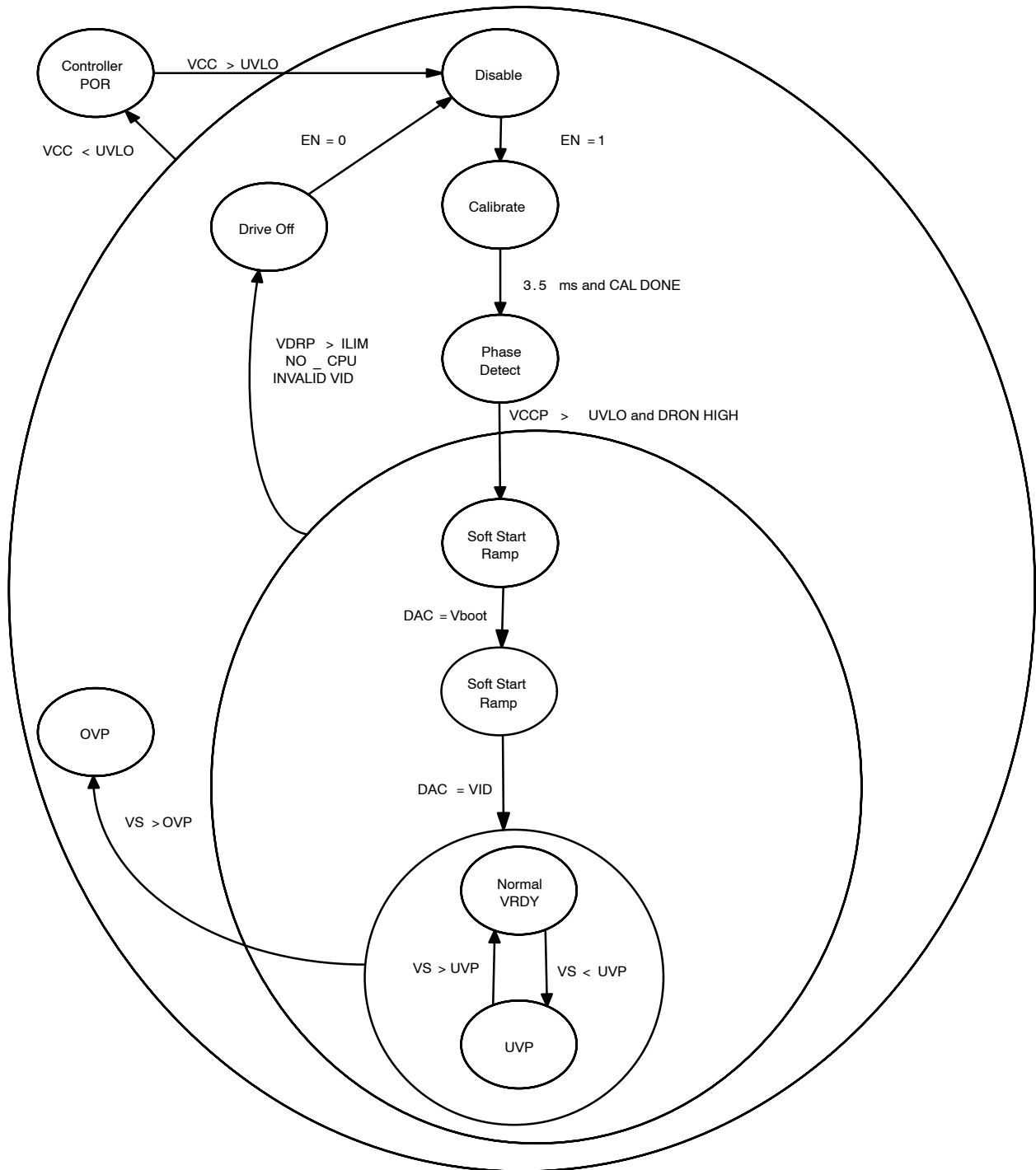

Figure 6. State Diagram

NCP6132A, NCP6132B

General

The NCP6132A/NCP6132B is a dual output three phase plus two phase dual edge modulated multiphase PWM controller designed to meet the Intel VR12 and IMVP-7 specifications with a serial SVID control interface. It is designed to work in notebook, desktop, and server applications.

User-set Phase and Driver Selection

NCP6132A/NCP6132B can be user-configured to operate under different phase and driver combinations. Phase selection for core and aux regulator can be set up separately by configuring the pin connections of CSP2, CSP3, CSP1A, and CSP2A. During start-up (before SVID is available), CSPx pins are monitored to detect user-set

configuration. If a pin is connected to VCC directly or through a low value (1 kΩ) resistor, the monitored input signal is driven to logic high indicating that the corresponding phase is disabled. Otherwise, if a pin is connected normally, the monitored input signal is driven to logic low and that phase is operational. During initialization, the configuration defined by CSPx is written into a User Configuration Register (UCR). If the detected configuration doesn't match any of the valid configurations listed in the table below then it is considered as unsupported. With an unsupported configuration the chip doesn't start switching but remains power-up. After initialization the UCR acts as a Read-Only reg.

The user configuration for core and aux regulator is shown as below:

No	Core Rail	Aux Rail	CSP2	CSP3	CSP1A	CSP2A	PART
1	2 int. + 1 ext.	1 int. + 1 ext.	normal	normal	Normal	normal	NCP6132A
2	2 int. + 1 ext.	1 int.	normal	normal	Normal	VCC	NCP6132A
3	2 int. + 1 ext.	off	normal	normal	VCC	VCC	NCP6132A
4	3 int.	2 ext.	normal	normal	Normal	normal	NCP6132B
5	3 int.	1 ext.	normal	normal	Normal	VCC	NCP6132B
6	3 int.	off	normal	normal	VCC	VCC	NCP6132B
7	2 int.	1 int. + 1 ext.	normal	VCC	Normal	normal	NCP6132A
8	2 int.	1 int.	normal	VCC	Normal	VCC	NCP6132A
9	2 int.	2 ext.	normal	VCC	Normal	normal	NCP6132B
10	2 int.	1 ext.	normal	VCC	Normal	VCC	NCP6132B
11	2 int.	off	normal	VCC	VCC	VCC	NCP6132A or NCP6132B
12	1 int.	1 int.	VCC	VCC	Normal	VCC	NCP6132A
13	1 int.	1 ext.	VCC	VCC	Normal	VCC	NCP6132B
14	1 int.	off	VCC	VCC	VCC	VCC	NCP6132A or NCP6132B

*NCP6132A supports configurations: 1, 2, 3, 7, 8, 11, 12 and 14; NCP6132B supports configurations: 4, 5, 6, 9, 10, 11, 13, 14.

*When both CSP1A and CSP2A are pulled to VCC, the aux regulator is totally disabled. It does not respond to any SVID command with address 01h.

NCP6132A, NCP6132B

If aux rail is disabled, the unused pins' connection should follow the below table:

UNUSED PIN CONNECTION WITH DISABLED AUX RAIL

Pin Name	Connect to
CSP1A	V _{CC}
CSP2A	V _{CC}
LGA	Float
SWA	Float
HGA	Float
BSTA	Float
VSPA	GND
VSNA	GND
DIFFA	Float
FBA	COMPA
COMPA	FBA
TRBSTA#	Float or V _{CC}
CSREFA	GND
CSCOMPA	CSSUMA
CSSUMA	CSCOMPA
DROOPA	CSCOMPA
ILIMA	Float
TSNSA	GND
IOUTA	GND
PWMA	Float

There are three integrated drivers: HG1/LG1, HG2/LG2 and HGA/LGA. There are 5 internal PWM signals: PWM1/2/3 from core controller and PWM1A/2A from aux controller. HG1/LG1 is driven by PWM1, HG2/LG2 is driven by PWM2, and HGA/LGA is driven by PWM1A when aux rail uses one internal driver, driven by PWM3 when core rail uses 3 internal drivers.

To drive the external drivers, NCP6132A/NCP6132B has two PWM signal outputs: PWM and PWMA, whose internal connections depend on the phase and driver configuration. For example, PWM can be driven by PWM3 when there is one external driver needed for core rail, or driven by PWM2A when aux rail requires two external drivers. Similarly, PWMA can be driven either by PWM1A or PWM2A. The detailed phase configuration table is shown below:

PHASE CONFIGURATION TABLE

	Aux 1 int. + 1 ext.	Aux 2 ext.	Aux 1 int.	Aux 1 ext.	Aux off
Core 2 int. + 1 ext.	Core drivers : HG1/LG1 HG2/LG2 PWM Aux drivers : HGA/LGA PWMA	No	Core drivers : HG1/LG1 HG2/LG2 PWM Aux drivers : HGA/LGA	No	Core drivers : HG1/LG1 HG2/LG2 PWM Aux drivers :
Core 3 int.	No	Core drivers : HG1/LG1 HG2/LG2 HGA/LGA Aux drivers : PWMA (phase 1) PWM (phase 2)	No	Core drivers : HG1/LG1 HG2/LG2 HGA/LGA Aux drivers : PWMA	Core drivers : HG1/LG1 HG2/LG2 HGA/LGA Aux drivers :
Core 2 int.	Core drivers : HG1/LG1 HG2/LG2 Aux drivers : HGA/LGA PWMA	Core drivers : HG1/LG1 HG2/LG2 Aux drivers : PWMA (phase 1) PWM (phase 2)	Core drivers : HG1/LG1 HG2/LG2 Aux drivers : HGA/LGA	Core drivers : HG1/LG1 HG2/LG2 Aux drivers : PWMA	Core drivers : HG1/LG1 HG2/LG2 Aux drivers :
Core 1 int.	No	No	Core drivers : HG1/LG1 Aux drivers : HGA/LGA	Core drivers : HG1/LG1 Aux drivers : PWMA	Core drivers : HG1/LG1 Aux drivers :

NCP6132A, NCP6132B

Phase Interleaving

When both core and graphic rails are in multiphase user configuration, NCP6132A/NCP6132B uses phase interleaved PWM operation for dual output rails, i.e., there's a phase shift between the two rails. The phase shift between core rail and aux rail is to ensure PWM on-cycle of each

interleaved phase has no overlap. It helps reduce the RMS current of the input capacitor connected to V_{in} and therefore lower power dissipation over capacitor ESR.

The interleaved phase angle for different phase configurations is shown in the following diagram.

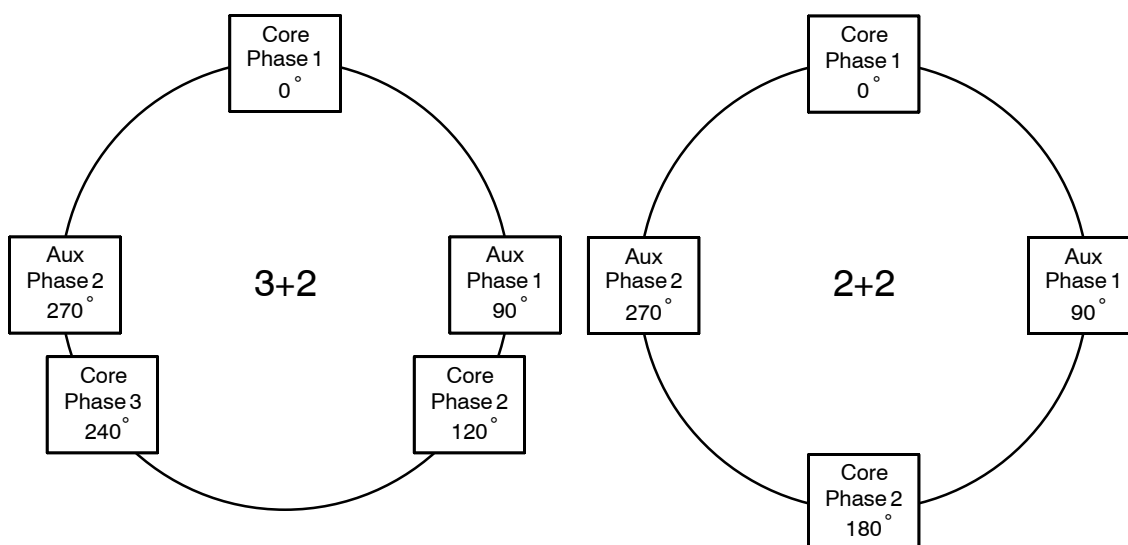

Figure 7. Interleaved Phases Diagram

Phase Shedding (PS)

The NCP6132A/NCP6132B supports phase shedding based by CPU/GPU PSx states. (Auto Phase Shedding triggered by user-set phase shedding threshold without any

PS state transition is not supported.) The NCP6132A/NCP6132B implements PS0, PS1, PS2 and PS3 power saving states for CPU/GPU shown as follows:

For CPU (3-phase or 2-phase user configuration):

Power Status		Phases Operating Mode	Control Method
PS0	Heavy load condition	Multi-phase interleaving	CF DEPWM
PS1	Medium load condition	Single-phase Forced CCM mode	QCF RPM
PS2/3	Light load condition	Single-phase Automatic CCM/DCM mode	VF RPM

For GPU (2-phase user configuration):

Power Status		Phases Operating Mode	Control Method
PS0	Heavy load condition	2-phase interleaving	CF DEPWM
PS1	Medium load condition	2-phase interleaving	CF DEPWM
PS2/3	Light load condition	Single-phase Automatic CCM/DCM mode	VF RPM

For CPU & GPU (1-phase user configuration):

Power Status		Phases Operating Mode	Control Method
PS0	Heavy load condition	Single-phase Forced CCM mode	QCF RPM
PS1	Medium load condition	Single-phase Forced CCM mode	QCF RPM
PS2/3	Light load condition	Single-phase Automatic CCM/DCM mode	VF RPM

*CF – Constant Frequency
 DEPWM – Dual Edge Pulse Width Modulation
 QCF – Quasi Constant Frequency
 RPM – Ramp Pulse Modulation
 VF – Variable Frequency

NCP6132A, NCP6132B

In PS2/3 state, transition from CCM to DCM is triggered by a Zero Current Detector (ZCD) latch. ZCD latch is set by a ZCD comparator monitoring switch node (SWN) voltage during PWM off-time. ZCD latch is reset at negative edge of PWM signal and is ready to be set after a set minimum PWM off-time delay. As SWN voltage is stably ramping up toward zero, if the SWN voltage crosses a set (a few negative mV) threshold, then ZCD latch is set and LG1 output is driven to logic low to turn off low-side power switch and phase is operating in DCM. If ZCD latch remains reset during PWM off-cycle, then the low-side power switch remains turned on and the phase is operating in CCM.

If aux phase 1 is configured with external driver, the driver should have built-in ZCD comparator (like NCP5911) to support DCM.

Transition from PS1 to PS0 state triggering phase shedding is called PS1 assertion. Similarly, PS2 assertion is the transition to PS2 state. Note that PS1 assertion in aux rail should be ignored as PS1 and PS0 have the same phase operating mode.

PS1 or PS2 assertion is ignored and user-set multiphase operation is enforced for the following circumstances: during startup, in current limit (CLIMx) operation, and during DVID transition.

Phase shedding is always from multiphase to single phase in one single step.

- For core rail:
 - ◆ Phase shedding from 3-phase is done by driving PWM output (internally connected to PWM3) to mid-level while DRVEN output is still driven to logic high, and by keeping both HG2, LG2 outputs to logic low.
 - ◆ Phase shedding from 2-phase is done by driving both HG2, LG2 outputs to logic low.
- For aux rail:
 - ◆ Phase shedding from 2-phase is done by driving both HGA, LGA outputs to logic low.

Transition from PS1/2/3 to PS0 state triggers phase un-shedding.

Phase un-shedding is instantaneous and happens from single-phase to user-set multiphase configuration in one single step.

Serial VID

The NCP6132A/NCP6132B supports the Intel serial VID interface. It communicates with the microprocessor through three wires (SCLK, SDIO, ALERT#). The table of supported registers is shown below.

Index	Name	Description	Access	Default
00h	Vendor ID	Uniquely identifies the VR vendor. The vendor ID assigned by Intel to ON Semiconductor is 0x1Ah	R	0x1Ah
01h	Product ID	Uniquely identifies the VR product. The VR vendor assigns this number.	R	0x00
02h	Product Revision	Uniquely identifies the revision or stepping of the VR control IC. The VR vendor assigns this data.	R	0x03
05h	Protocol ID	Identifies the SVID Protocol the NCP6132A/NCP6132B supports	R	0x01
06h	Capability	Informs the Master of the NCP6132A/NCP6132B's Capabilities, 1 = supported, 0 = not supported Bit 7 = I _{out} format. Bit 7 = 0 when 1A = 1LSB of Reg 15h. Bit 7 = 1 when Reg 15 FFh = I _{cc} Max. Default = 1 Bit 6 = ADC Measurement of Temp Supported = 1 Bit 5 = ADC Measurement of Pin Supported = 0 Bit 4 = ADC Measurement of V _{in} Supported = 0 Bit 3 = ADC Measurement of I _{in} Supported = 0 Bit 2 = ADC Measurement of P _{out} Supported = 1 Bit 1 = ADC Measurement of V _{out} Supported = 1 Bit 0 = ADC Measurement of I _{out} Supported = 1	R	0xC7
10h	Status_1	Data register read after the ALERT# signal is asserted. Conveying the status of the VR.	R	00h
11h	Status_2	Data register showing optional status_2 data.	R	00h
12h	Temp zone	Data register showing temperature zones the system is operating in	R	00h
15h	I _{out}	8 bit binary word ADC of current. This register reads 0xFF when the IOUT(A) pin voltage is 2 V. The IOUT(A) voltage should be scaled with an external resistor to ground such that a load equal to I _{cc} Max generates a 2 V signal.	R	01h
16h	V _{out}	8 bit binary word ADC of output voltage, measured between VSP and VSN. LSB size is 8 mV	R	01h
17h	VR_Temp	8 bit binary word ADC of voltage. Binary format in deg C, IE 100C = 64h. A value of 00h indicates this function is not supported	R	01h

NCP6132A, NCP6132B

Index	Name	Description	Access	Default
18h	P_out	8 bit binary word representative of output power. The output voltage is multiplied by the output current value and the result is stored in this register. A value of 00h indicates this function is not supported	R	01h
1Ch	Status 2 Last read	When the status 2 register is read its contents are copied into this register. The format is the same as the Status 2 Register.	R	00h
21h	Icc_Max	Data register containing the Icc_Max the platform supports. The value is measured on the ICCMAX pin on power up and placed in this register. From that point on the register is read only.	R	00h
22h	Temp_Max	Data register containing the max temperature the platform supports and the level VR_hot asserts. This value defaults to 100°C and programmable over the SVID Interface	R/W	64h
24h	SR_fast	Slew Rate for SetVID_fast commands. Binary format in mV/μs.	R	0Ah
25h	SR_slow	Slew Rate for SetVID_slow commands. It is 4X slower than the SR_fast rate. Binary format in mV/μs	R	02h
26h	Vboot	The NCP6132A/NCP6132B will ramp to Vboot and hold at Vboot until it receives a new SVID SetVID command to move to a different voltage. Default value = 0 V.	R	00h
30h	Vout_Max	Programmed by master and sets the maximum VID the VR will support. If a higher VID code is received, the VR should respond with "not supported" acknowledge. VR 12 VID format.	RW	FBh
31h	VID setting	Data register containing currently programmed VID voltage. VID data format.	RW	00h
32h	Pwr State	Register containing the current programmed power state.	RW	00h
33h	Offset	Sets offset in VID steps added to the VID setting for voltage margining. Bit 7 is sign bit, 0 = positive margin, 1 = negative margin. Remaining 7 BITS are # VID steps for margin 2s complement. 00h = no margin 01h = +1 VID step 02h = +2 VID steps FFh = -1 VID step FEh = -2 VID steps.	RW	00h
34h	MultiVR Config			

For NCP6132A/NCP6132B, VID code change is supported by SVID interface with three options as below:

Option	SVID Command Code	Feature	Register Address (Indicating the slew rate of VID code change)
SetVID_Fast	01h	>10 mV/μs VID code change slew rate	24h
SetVID_Slow	02h	=1/4 of SetVID_Fast VID code change slew rate	25h
SetVID_Decay	03h	No slew rate control, VID code down	N/A

Boot Voltage Programming

The NCP6132A/NCP6132B has a VBOOT voltage register that can be externally programmed for both core and aux boot-up output voltage. The VBOOT voltage can be programmed with a resistor from VBOOT pin to GND, or it can be set to 1.1 V by connecting VBOOT pin to GND to facilitate mass production. See the Boot Voltage Table.

BOOT VOLTAGE TABLE

Boot Voltage (V)	Resistor Value (Ω)
0	10k
0.9	20k
1.0	30k
1.1	40k Or connect VBOOT pin to GND
1.2	50k
1.35	60k Or connect VBOOT pin to V _{CC}

SVID Addressing

The NCP6132A/NCP6132B has fixed SVID device addresses for core and aux rail. The core rail address is 0000, and aux rail address is 0001.

Remote Sense Amplifier

A high performance high input impedance true differential amplifier is provided to accurately sense the output voltage of the regulator. The VSP and VSN inputs should be connected to the regulator’s output voltage sense points. The remote sense amplifier takes the difference of the output voltage with the DAC voltage and adds the droop voltage to

$$V_{DIFF} = (V_{VSP} - V_{VSN}) + (1.3V - V_{DAC}) + (V_{DROOP} - V_{CSREF}) \quad (eq. 1)$$

This signal then goes through a standard error compensation network and into the inverting input of the error amplifier. The non-inverting input of the error amplifier is connected to the same 1.3 V reference used for the differential sense amplifier output bias.

High Performance Voltage Error Amplifier

A high performance error amplifier is provided for high bandwidth transient performance. A standard type 3 compensation circuit is normally used to compensate the system.

Differential Current Feedback Amplifiers

Each phase has a low offset differential amplifier to sense that phase current for current balance and per phase OCP protection during soft-start. The inputs to the CSREF and CSPx pins are high impedance inputs. It is recommended that any external filter resistor RCSN not exceed 10 kΩ to avoid offset issues with leakage current. It is also recommended that the voltage sense element be no less than 0.5 mΩ for accurate current balance. Fine tuning of this time constant is generally not required.

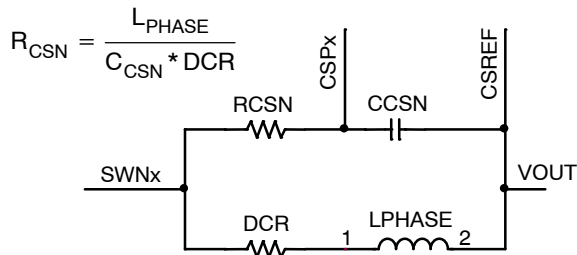

Figure 8.

The individual phase current is summed into to the PWM comparator feedback in this way current is balanced is via a current mode control approach.

Total Current Sense Amplifier

The NCP6132A/NCP6132B uses a patented approach to sum the phase currents into a single temperature

compensated total current signal. This signal is then used to generate the output voltage droop, total current limit, and the output current monitoring functions. The total current signal is floating with respect to CSREF. The current signal is the difference between CSCOMP and CSREF. The Ref(n) resistors sum the signals from the output side of the inductors to create a low impedance virtual ground. The amplifier actively filters and gains up the voltage applied across the inductors to recover the voltage drop across the inductor series resistance (DCR). Rth is placed near an inductor to sense the temperature of the inductor. This allows the filter time constant and gain to be a function of the Rth NTC resistor and compensate for the change in the DCR with temperature.

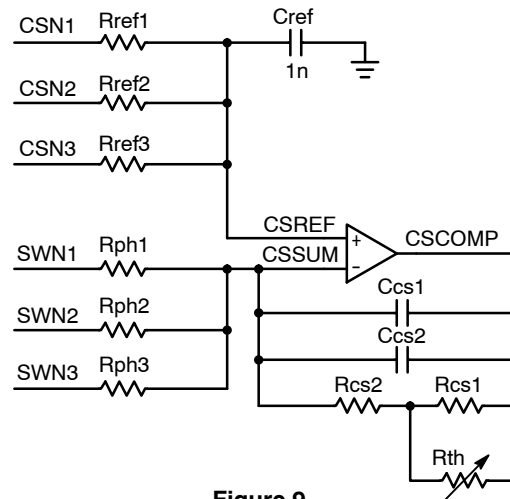

Figure 9.

The DC gain equation for the current sensing:

$$V_{CSCOMP-CSREF} = \frac{Rcs2 + \frac{Rcs1 * Rth}{Rcs1 + Rth}}{Rph} * (I_{out_Total} * DCR) \quad (eq. 2)$$

Set the gain by adjusting the value of the Rph resistors. The DC gain should set to the output voltage droop. If the voltage from CSCOMP to CSREF is less than 100 mV at ICCMAX then it is recommended to increase the gain of the CSCOMP amp and add a resistor divider to the Droop pin filter. This is required to provide a good current signal to offset voltage ratio for the ILIM pin. When no droop is needed, the gain of the amplifier should be set to provide ~100 mV across the current limit programming resistor at full load. The values of Rcs1 and Rcs2 are set based on the 220k NTC and the temperature effect of the inductor and should not need to be changed. The NTC should be placed near the closest inductor. The output voltage droop should be set with the droop filter divider.

The pole frequency in the CSCOMP filter should be set equal to the zero from the output inductor. This allows the circuit to recover the inductor DCR voltage drop current

signal. Ccs1 and Ccs2 are in parallel to allow for fine tuning of the time constant using commonly available values. It is best to fine tune this filter during transient testing.

$$F_Z = \frac{DCR@25^\circ C}{2 * \pi * L_{Phase}} \quad (\text{eq. 3})$$

$$F_P = \frac{1}{2 * \pi * \left(R_{cs2} + \frac{R_{cs1} * R_{th}@25^\circ C}{R_{cs1} + R_{th}@25^\circ C} \right) * (C_{cs1} + C_{cs2})} \quad (\text{eq. 4})$$

Programming the Current Limit

The current-limit thresholds are programmed with a resistor between the ILIM and CSCOMP pins. The ILIM pin mirrors the voltage at the CSREF pin and mirrors the sink current internally to IOUT (reduced by the IOUT Current Gain) and the current limit comparators. Set the value of the current limit resistor based on the user-set output current limit I_{out_LIMIT} or CSREF- CSCOMP voltage at I_{out_LIMIT} condition as shown below:

$$R_{ILIM} = \frac{R_{cs2} + \frac{R_{cs1} * R_{th}}{R_{cs1} + R_{th}} * (I_{out_LIMIT} * DCR)}{10 \mu A} \quad (\text{eq. 5})$$

or

$$R_{ILIM} = \frac{V_{CSREF-CSCOMP@ILIMIT}}{10 \mu A} \quad (\text{eq. 6})$$

Programming DROOP and DAC Feed-Forward Filter

The signals DROOP and CSREF are differentially summed with the output voltage feedback to add precision voltage droop to the output voltage. The total current feedback should be filtered before it is applied to the DROOP pin. This filter impedance provides DAC feed-forward during dynamic VID changes. Programming this filter can be made simpler if CSCOMP-CSREF is equal to the droop voltage. Rdroop sets the gain of the DAC feed-forward and Cdroop provides the time constant to cancel the time constant of the system per the following equations. Cout is the total output capacitance and Rout is the output impedance of the system.

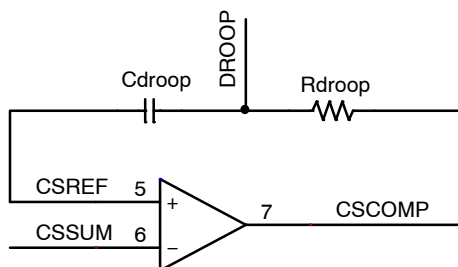

$$R_{droop} = C_{out} * R_{out} * 453.6 \times 10^6$$

$$C_{droop} = \frac{R_{out} * C_{out}}{R_{droop}}$$

Figure 10.

If the Droop at maximum load is less than 100 mV at ICCMAX we recommend altering this filter into a voltage divider such that a larger signal can be provided to the ILIM resistor by increasing the CSCOMP amp gain for better current monitor accuracy. The DROOP pin divider gain should be set to provide a voltage from DROOP to CSREF equal to the amount of voltage droop desired in the output. A current is applied to the DROOP pin during dynamic VID. In this case Rdroop1 in parallel with Rdroop2 should be equal to Rdroop.

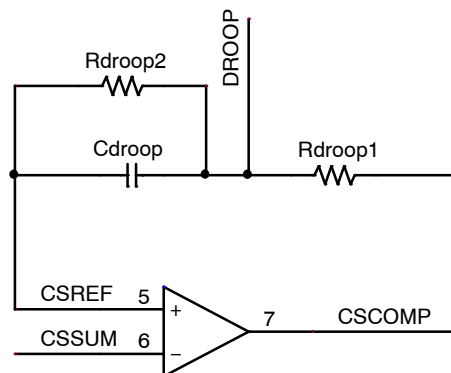

Figure 11.

Programming IOUT

The IOUT pin sources a current equal to the ILIM sink current gained by the IOUT Current Gain. The voltage on the IOUT pin is monitored by the internal A/D converter and should be scaled with an external resistor to ground such that a load equal to ICCMAX generates a 2 V signal on IOUT. A pull-up resistor from 5 V VCC can be used to offset the IOUT signal positive if needed.

$$R_{IOUT} = \frac{2.0 V * R_{LIMIT}}{10 * \left(R_{cs2} + \frac{R_{cs1} * R_{th}}{R_{cs1} + R_{th}} * (I_{out_ICC_MAX} * DCR) \right)} \quad (\text{eq. 7})$$

Programming ICC_MAX and ICC_MAXA

The SVID interface provides the platform ICC_MAX value at register 21h for both the core and the aux rails. A resistor to ground on the PWM and PWMA pins program these registers at the time the part is enabled. 10 μA is sourced from these pins to generate a voltage on the program resistor. The value of the register is 1 A per LSB and is set by the equation below. The resistor value should be no less than 10 k.

$$ICC_MAX_{21h} = \frac{R * 10 \mu A * 256 A}{2 V} \quad (\text{eq. 8})$$

Programming TSNS and TSNSA

Two temperature sense inputs are provided. A precision current is sourced out the output of the TSNS and TSNSA pins to generate a voltage on the temperature sense network. The voltages on the temperature sense inputs are sampled by

the internal A/D converter and then digitally converted to temperature and stored in SVID register 17h. A 100 k NTC should be used. The Rcomp1 and Rcomp2 vary with NTC's temperature characteristics.

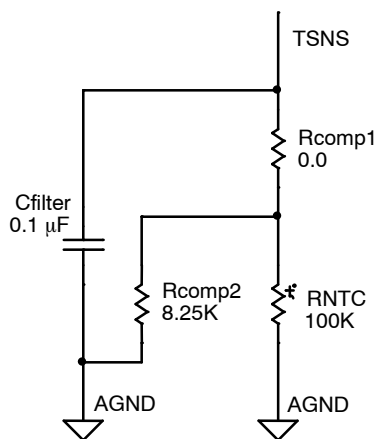

Figure 12.

Precision Oscillator

A programmable precision oscillator is provided. The clock oscillator serves as the master clock to the ramp generator circuit. This oscillator is programmed by a resistor to ground on the ROSC pin. The ROSC pin provides approximately 2 V out and the source current is mirrored into the internal ramp oscillator. The oscillator generates triangle ramps that are 0.5 ~ 2.5 V in amplitude depending on the VRMP pin voltage to provide input voltage feed forward compensation. The oscillator frequency is approximately proportional to the current flowing in the ROSC resistor.

$$f_{OSC} = \frac{1}{2 \left(\frac{V_{OSC}}{V_{ref}} R_{OSC} C_{OSC} + 2t_d \right)} \quad (eq. 9)$$

Where

- f_{OSC} PWM master oscillator frequency
- V_{OSC} oscillator ramp peak-to-peak voltage (1 V)
- V_{ref} ROSC pin reference voltage (2 V)
- R_{OSC} ROSC pin frequency setting resistor
- C_{OSC} oscillator timing capacitor (2.5 pF)
- t_d oscillator loop delay (10 ns)

And the per phase switching frequency f_{sw} is given by

$$f_{sw} = \frac{f_{OSC}}{12} \quad (eq. 10)$$

The switching frequency range is between 200 kHz/phase to 800 kHz/phase.

Programming the Ramp Feed-Forward Circuit

The ramp generator circuit provides the ramp used by the PWM comparators. The ramp generator provides voltage feed-forward control by varying the ramp magnitude with

respect to the VRMP pin voltage. The VRMP pin also has a 4 V UVLO function. The VRMP UVLO is only active after the controller is enabled. The VRMP pin is a high impedance input when the controller is disabled.

The PWM ramp time is changed according to the following,

$$V_{RAMPpk=pk_{pp}} = 0.1 * V_{VRMP} \quad (eq. 11)$$

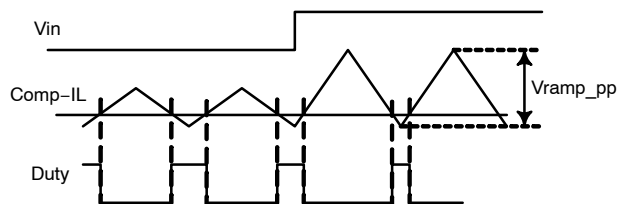

Figure 13.

Programming TRBST#

The TRBST# pin provides a signal to offset the output after load release overshoot. This network should be fine tuned during the board tuning process and is only necessary in systems with significant load release overshoot. The TRBST# network allows maximum boost for low frequency load release events to minimize load release ringing back undershoot. The network time constants are set up to provide a TRBST# roll of at higher frequencies where it is not needed. Cboost1 * Rbst1 controls the time constant of the load release boost. This should be set to counter the under shoot after load release. Rbst1 + Rbst2 controls the maximum amount of boost during rapid step loading. Rbst2 is generally much larger than Rbst1. The Cboost2 * Rbst2 time constant controls the roll off frequency of the TRBST# function.

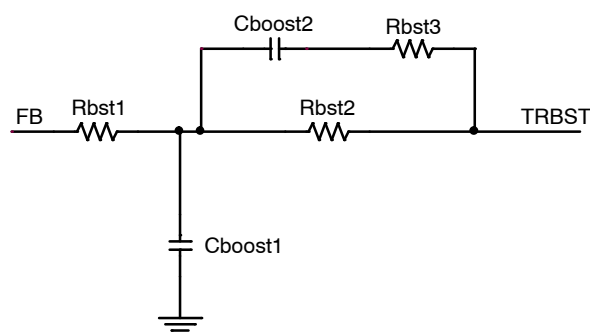

Figure 14.

PWM Comparators

During steady state operation, the duty cycle is centered on the valley of the triangle ramp waveform and both edges of the PWM signal are modulated. During a transient event the duty will increase rapidly and proportionally turning on all phases as the error amp signal increases with respect to the ramps to provide a highly linear and proportional response to the step load.

PROTECTION FEATURES

Input Under Voltage Protection

NCP6132A/NCP6132B monitors the 5 V VCC supply and the VRMP pin for under voltage protection. The gate driver monitors both the gate driver VCC and the BST voltage. When the voltage on the gate driver is insufficient it will pull HG1, HG2, HGA, LG1, LG2, LGA, DRVEN low and notify the controller the power is not ready. The gate driver will hold HG1, HG2, HGA, LG1, LG2, LGA, DRVEN low for a minimum period of time to allow the controller to restart its startup sequence. In this case the PWM and PWMA are set back to the MID state and soft start would begin again. See the figure below.

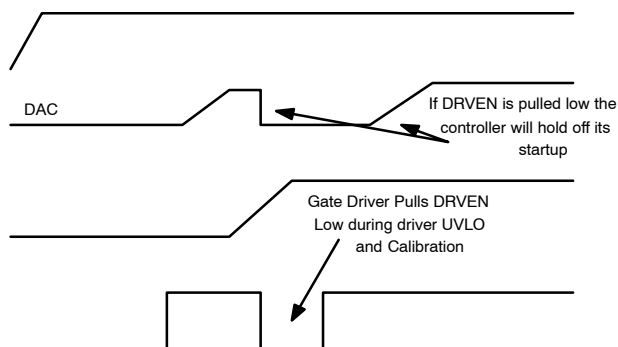

Figure 15. Gate Driver UVLO Restart

Soft Start

Soft start is implemented internally. A digital counter steps the DAC up from zero to the target voltage based on the predetermined slew rate in the spec table. The PWM signals will start out open with a test current to collect data on IMAX/IMAXA and for setting internal registers. After the IMAX/IMAXA configuration data is collected the controller enables and sets the PWM signal to the 2.0 V MID state to indicate that the drivers should be in diode mode. DRVON will then be asserted and the COMP pin released to begin soft-start. The DAC will ramp from Zero to the target DAC codes and the PWM outputs will begin to fire. Each phase will move out of the MID state when the first PWM pulse is produced preventing the discharge of a pre-charged output.

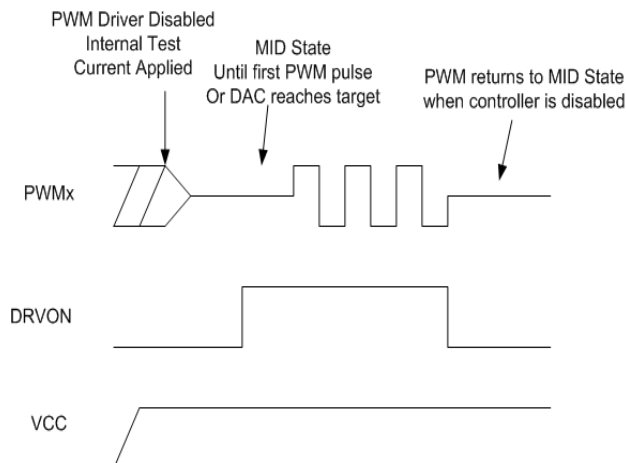

Figure 16. Soft-Start Sequence

Over Current Latch- Off Protection

The NCP6132A/NCP6132B provides two different types of current limit protection. During normal operation a programmable total current limit is provided that scales with the phase count during power saving operation. A second fixed per-phase current limit is provided for VID lower than 0.25 V, such as during soft-start.

The level of total current limit is set with the resistor from the ILIM pin to CSCOMP pin. Internally the current through ILIM pin is scaled and then compared to two current thresholds 10 μ A and 15 μ A, where 10 μ A threshold is scaled to indicate the 100% current limit and 15 μ A indicates the 150% current limit. If 100% current limit is exceeded, an internal latch-off counter starts. The controller shuts down if the over current fault is not removed after 50 μ s. If 150% current limit is exceeded, the controller shuts down immediately. To recover from an OCP fault the EN pin must be cycled low. The current limit is scaled down along with the phase shedding. Phase shedding from 3-phase to single phase scales the current limit to its 1/3; phase shedding from 2-phase to single phase scales the current limit to its half. For example, for a 3-phase design in PS0 state the 100% current limit trips if ILIM current exceeds 10 μ A, but in PS1/2/3 state (phase shedding to single phase) ILIM current above 3.3 μ A will trigger the 100% current limit.

Under Voltage Monitor

The output voltage is monitored at the output of the differential amplifier for UVLO. If the output falls more than 300 mV below the DAC-DROOP voltage the UVLO comparator will trip sending the VRDY/VRDYA signal low.

Over Voltage Protection

During normal operation the output voltage is monitored at the differential inputs VSP and VSN. If the output voltage exceeds the DAC voltage by approximately 250 mV, LGx from integrated drivers will be forced high and PWM/PWMA will be forced low when OVP is triggered. And then the DAC will ramp down to zero to avoid a negative output voltage spike during shutdown. When the DAC gets to zero, LGx will be forced high and PWM/PWMA will be forced low with DRVEN remaining high. To reset the part the EN pin must be cycled low.

During soft-start & DVID, the OVP has a fix threshold at 1.75 V.

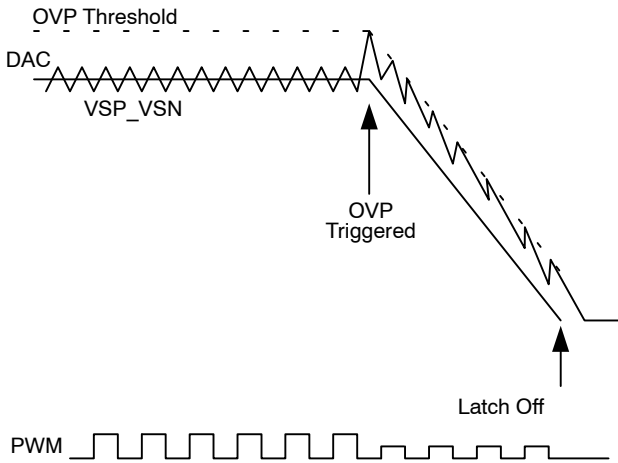

Figure 17. OVP Threshold Behavior

Layout Notes

The NCP6132A/NCP6132B has differential voltage and current monitoring. This improves signal integrity and reduces noise issues related to layout for easy design use. To insure proper function there are some general rules to follow:

Careful layout in per phase and total current sensing are critical for jitter minimization, accurate current balancing and ILIM and IOUT monitoring. Give the first priority in component placement and trace routing to per phase and total current sensing circuit. The per phase inductor current sense RC filters should always be placed as close to the CSREF and CSP pins on the controller as possible. The filter cap from CSCOMP to CSREF should also be close to the controller. The temperature-compensate resistor R_{TH} should be placed as close as possible to the Phase 1 inductor. The wiring path between R_{CSx} and R_{PHx} should be kept as short as possible and well away from switch node lines. The Refx resistors (10 Ω) connected to CSREF pin should be placed near the inductors to reduce the length of traces. The resistors R_{PHx} are better to have 0603 package. The above layout notes are shown in Figure 18.

Place the V_{CC} decoupling caps as close as possible to the controller VCC pin. For any RC filter on the VCC and VDDBP pins, the resistor should be no higher than 2.2 Ω to prevent large voltage drop.

The small high feed back cap from COMP to FB should be as close to the controller as possible. Keep the FB traces short to minimize their capacitance to ground.

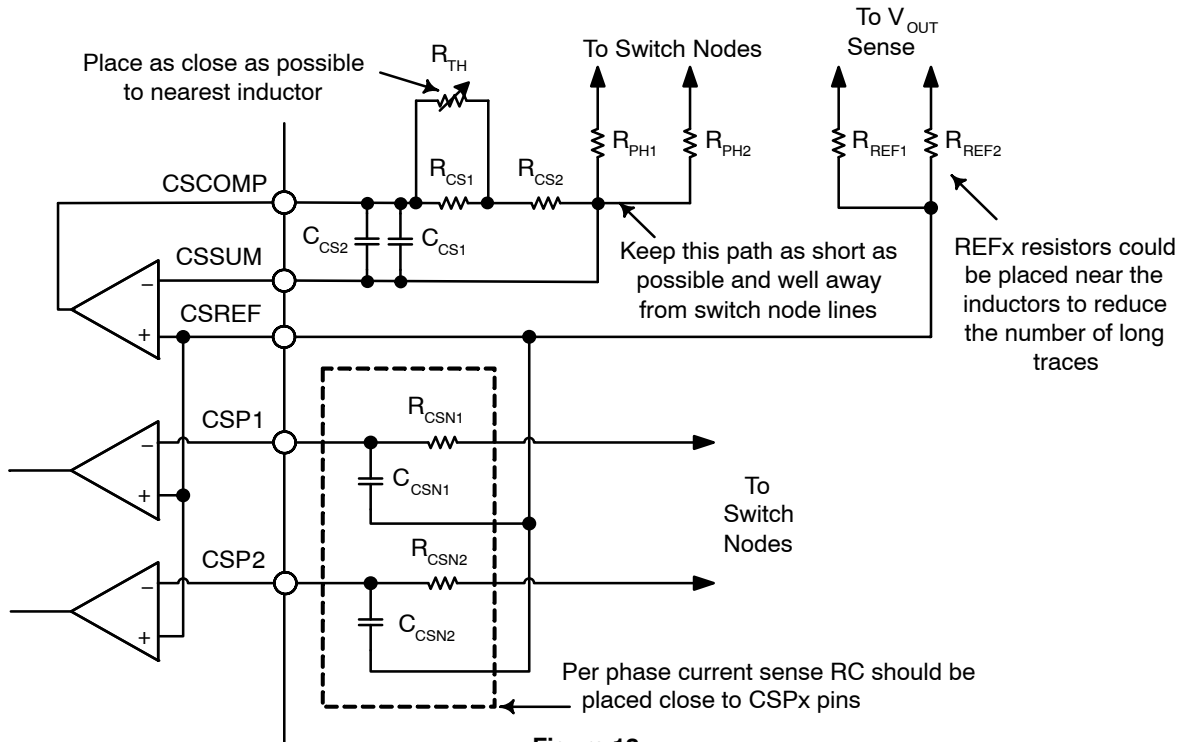
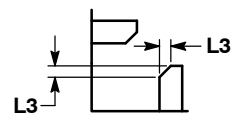
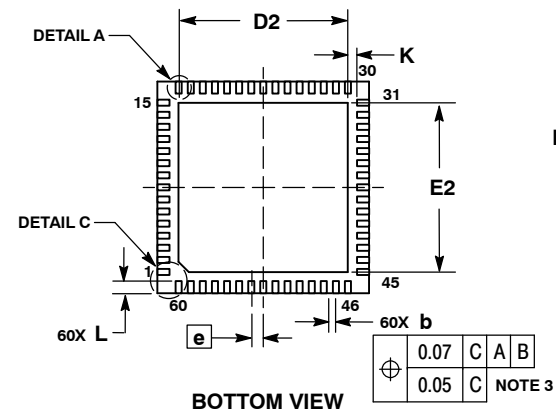
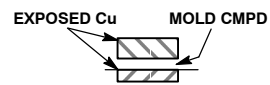
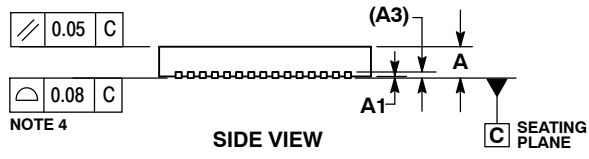
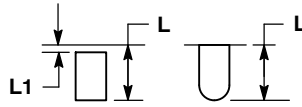
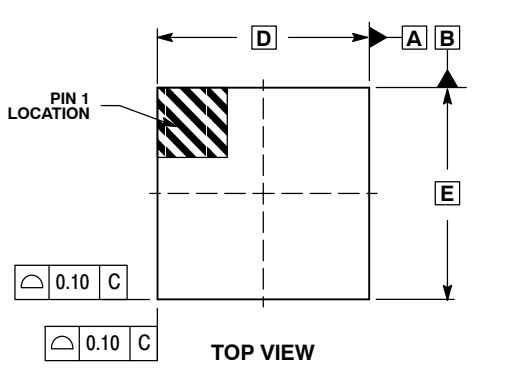

Figure 18.

NCP6132A, NCP6132B

PACKAGE DIMENSIONS

QFN60 7x7, 0.4P
CASE 485BB-01
ISSUE A



- NOTES:
1. DIMENSIONS AND TOLERANCING PER ASME Y14.5M, 1994.
 2. CONTROLLING DIMENSION: MILLIMETERS.
 3. DIMENSION b APPLIES TO THE PLATED TERMINAL AND IS MEASURED ABETWEEN 0.15 AND 0.30 MM FROM TERMINAL TIP.
 4. COPLANARITY APPLIES TO THE EXPOSED PAD AS WELL AS THE TERMINALS.

DIM	MILLIMETERS	
	MIN	MAX
A	0.80	1.00
A1	0.00	0.05
A3	0.20 REF	
b	0.15	0.25
D	7.00 BSC	
D2	5.50	5.70
E	7.00 BSC	
E2	5.50	5.70
e	0.40 BSC	
K	0.30 REF	
L	0.30	0.50
L1	---	0.15
L3	0.10 REF	

RECOMMENDED SOLDERING FOOTPRINT*

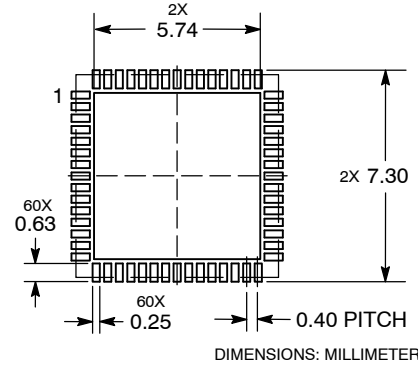

*For additional information on our Pb-Free strategy and soldering details, please download the ON Semiconductor Soldering and Mounting Techniques Reference Manual, SOLDERRM/D.

ON Semiconductor and are registered trademarks of Semiconductor Components Industries, LLC (SCILLC). SCILLC reserves the right to make changes without further notice to any products herein. SCILLC makes no warranty, representation or guarantee regarding the suitability of its products for any particular purpose, nor does SCILLC assume any liability arising out of the application or use of any product or circuit, and specifically disclaims any and all liability, including without limitation special, consequential or incidental damages. "Typical" parameters which may be provided in SCILLC data sheets and/or specifications can and do vary in different applications and actual performance may vary over time. All operating parameters, including "Typicals" must be validated for each customer application by customer's technical experts. SCILLC does not convey any license under its patent rights nor the rights of others. SCILLC products are not designed, intended, or authorized for use as components in systems intended for surgical implant into the body, or other applications intended to support or sustain life, or for any other application in which the failure of the SCILLC product could create a situation where personal injury or death may occur. Should Buyer purchase or use SCILLC products for any such unintended or unauthorized application, Buyer shall indemnify and hold SCILLC and its officers, employees, subsidiaries, affiliates, and distributors harmless against all claims, costs, damages, and expenses, and reasonable attorney fees arising out of, directly or indirectly, any claim of personal injury or death associated with such unintended or unauthorized use, even if such claim alleges that SCILLC was negligent regarding the design or manufacture of the part. SCILLC is an Equal Opportunity/Affirmative Action Employer. This literature is subject to all applicable copyright laws and is not for resale in any manner.

PUBLICATION ORDERING INFORMATION

LITERATURE FULFILLMENT:
Literature Distribution Center for ON Semiconductor
P.O. Box 5163, Denver, Colorado 80217 USA
Phone: 303-675-2175 or 800-344-3860 Toll Free USA/Canada
Fax: 303-675-2176 or 800-344-3867 Toll Free USA/Canada
Email: orderlit@onsemi.com

N. American Technical Support: 800-282-9855 Toll Free USA/Canada
Europe, Middle East and Africa Technical Support:
Phone: 421 33 790 2910
Japan Customer Focus Center
Phone: 81-3-5817-1050

ON Semiconductor Website: www.onsemi.com
Order Literature: <http://www.onsemi.com/orderlit>
For additional information, please contact your local Sales Representative

Looking for pricing, stock, or lifecycle information?

Click below to explore more details on WIN SOURCE:

- ⊖ [View NCP6132ADMNR2G on WIN SOURCE](#)
- ⊖ [ON Semiconductor Information](#)

Optimize Your Supply Chain with WIN SOURCE Solutions

- ✓ Global Sourcing Solution
- ✓ Obsolete Management
- ✓ Cost Control Management
- ✓ Shortage Management
- ✓ Alternative Solution
- ✓ Excess Inventory Management