



**THE DATASHEET OF  
TPS22985YFPR**



# Thunderbolt™ SUPPLY SELECTION IC

Check for Samples: [TPS22985](#)

## FEATURES

- 2.8 V to 19.8 V
- Auto Selects 3.3 V Supply
- > 10-mA Low Power Switch
- > 500-mA High Power Switch
- Reverse Current Blocking From OUT to VDD
- Wake on UART Input Activity
- UART RX and TX Buffers

## APPLICATIONS

- Thunderbolt™ Cables
- Notebook Computers
- Desktop Computers
- Power Management Systems

## DESCRIPTION

The TPS22985 is a supply selection device for active Thunderbolt™ cables. The device selects a supply that is at 3.3V from two supply inputs and connects this to two non-current limited outputs OUTA and OUTB. When 3.3V is not present at either supply, the outputs become high impedance.

The TPS22985 has two modes of operation, Normal and Control.

In Normal Mode, OUTA is always on when a valid supply is present. OUTB is connected to a valid VDD when the ENB input is high.

In Control Mode, OUTA functions the same as Normal Mode and OUTB is controlled by a combination of monitored inputs and valid supplies on VDD1 and VDD2. When a valid VDD is available, the device waits for a rising input on ENB and then disconnects OUTB until the next falling RXH transition. Once the next falling RXH transition occurs, the device reconnects OUTB.

In either mode, when a valid VDD is not available, the TPS22985 opens all switches and the outputs OUTA and OUTB become high impedance. When the connected VDD exceeds a maximum voltage of 3.6V, it is disconnected from the outputs. VDD2 will only connect when it is in the valid range and VDD1 is greater than 3.6V

The TPS22985 is available in a 1.6mm x 1.6mm WCSP package.

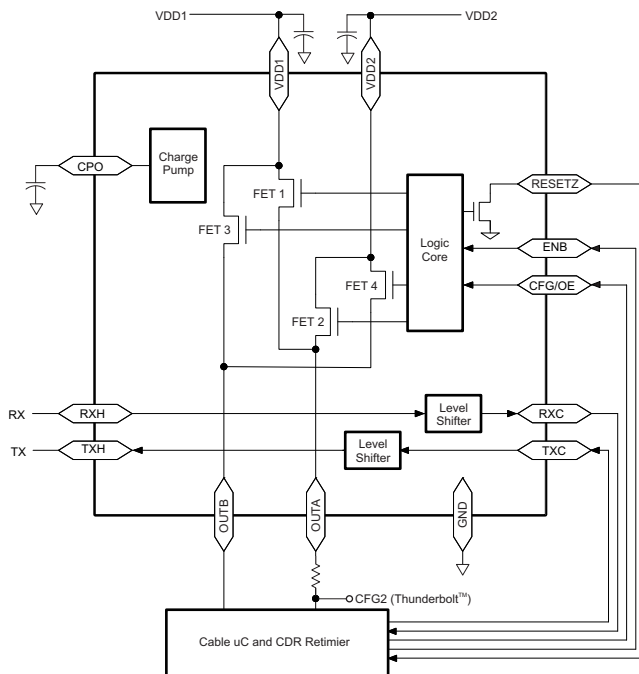

Figure 1. Typical Application



Please be aware that an important notice concerning availability, standard warranty, and use in critical applications of Texas Instruments semiconductor products and disclaimers thereto appears at the end of this data sheet.

Thunderbolt is a trademark of Intel Corporation.



These devices have limited built-in ESD protection. The leads should be shorted together or the device placed in conductive foam during storage or handling to prevent electrostatic damage to the MOS gates.

**ORDERING INFORMATION**

PART NUMBER	PACKAGE MARKING <sup>(1)</sup>	PACKAGE	DEVICE SPECIFIC FEATURES
TPS22985YFP	YMD9US	YFP	WCSP

(1) Y= Year, M = Month, D = Sequence Code, 9U = TPS22985 Device Code, S = Wafer Fab/Assembly Site Code

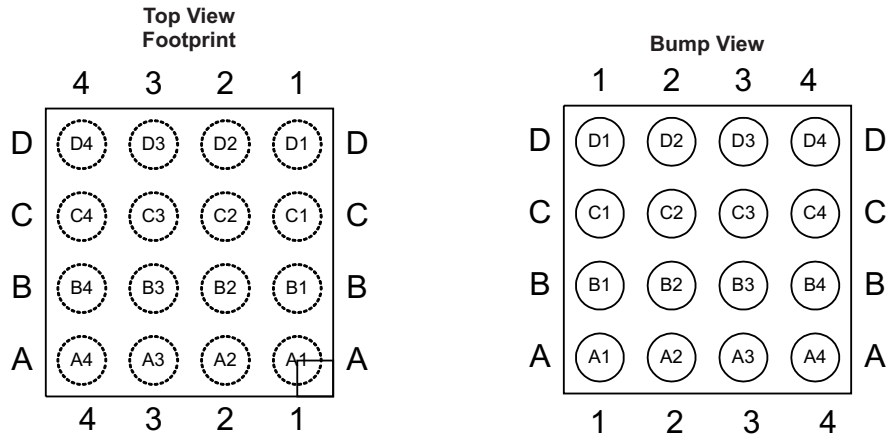

Die Size: 1.6mm x 1.6mm  
 Bump Size: 0.25mm  
 Bump Pitch: 0.4mm

**Table 1. TPS22985 Pin Mapping (Top View)**

	4	3	2	1
D	VDD1	VDD1	VDD2	VDD2
C	OUTA	OUTB	OUTB	GND
B	RXH	TXH	RESETZ	CPO
A	RXC	TXC	ENB	CFG/OE

**DISSIPATION RATINGS**

PACKAGE	THERMAL RESISTANCE $\theta_{JA}$	THERMAL RESISTANCE <sup>(1)</sup> $\theta_{JB}$	POWER RATING $T_A = 25^\circ\text{C}$	DERATING FACTOR ABOVE <sup>(2)</sup> $T_A = 25^\circ\text{C}$
YFP	95°C/W	63°C/W	1050 mW	10.5 mW/°C

(1) Simulated with high-K board

(2) Maximum power dissipation is a function of  $T_{J(max)}$ ,  $\theta_{JA}$  and  $T_A$ . The maximum allowable power dissipation at any allowable ambient temperature is  $P_D = (T_{J(max)} - T_A) / \theta_{JA}$ .

## ABSOLUTE MAXIMUM RATINGS

 over operating free-air temperature range (unless otherwise noted)<sup>(1) (2)</sup>

		VALUE	UNIT
V <sub>I</sub>	Voltage range on VDD1, VDD2, OUTA, OUTB <sup>(3)</sup>	–0.3 to 20	V
	Voltage range on RXC, TXC, RESETZ, CFG/OE, ENB <sup>(3)</sup> (VDD is the active 3.3V input)	–0.3 to VDD+0.3	V
	Voltage range on CPO	–0.3 to 13	V
	Voltage range on RXH, TXH	–0.3 to 4.0	V
T <sub>A</sub>	Operating ambient temperature range	–40 to 85	°C
T <sub>J (MAX)</sub>	Maximum operating junction temperature	125	°C
T <sub>stg</sub>	Storage temperature range	–65 to 150	°C
	Charge Device Model (JESD 22 C101)	350	V
	Human Body Model (JESD 22 A114)	2	kV
	Contact discharge on VDD1, VDD2 (IEC 61000-4-2) <sup>(4)</sup>	4.4	kV

- (1) Stresses beyond those listed under absolute maximum ratings may cause permanent damage to the device. These are stress ratings only, and functional operation of the device at these or any other conditions beyond those indicated under recommended operating conditions is not implied. Exposure to absolute–maximum–rated conditions for extended periods may affect device reliability.
- (2) In applications where high power dissipation and/or poor package thermal resistance is present, the maximum ambient temperature may have to be derated. Maximum ambient temperature [T<sub>A(max)</sub>] is dependent on the maximum operating junction temperature [T<sub>J(max)</sub>], the maximum power dissipation of the device in the application [P<sub>D(max)</sub>], and the junction-to-ambient thermal resistance of the part/package in the application (θ<sub>JA</sub>), as given by the following equation: T<sub>A(max)</sub> = T<sub>J(max)</sub> – (θ<sub>JA</sub> × P<sub>D(max)</sub>)
- (3) All voltage values are with respect to network ground terminal.
- (4) IEC tests are run with 0.1 μF on VDD1 and VDD2. IEC rating is non-destructive.

## RECOMMENDED OPERATING CONDITIONS

		MIN	MAX	UNIT
V <sub>DD1</sub> V <sub>DD2</sub>	Supply voltage range	2.8	19.8	V
		2.8	19.8	
I <sub>LIM1/2</sub>	FET1 and FET2 switch current range	0	10	mA
I <sub>LIM3/4</sub>	FET3 and FET4 switch current range	0	500	mA
V <sub>IH</sub>	Input logic high	RXH, TXC, CFG/OE, ENB	2	V
V <sub>IL</sub>	Input logic low	RXH, TXC, CFG/OE, ENB	0.8	V
V <sub>OH</sub>	Output logic high	RXC, TXH, RESETZ	2.25	V
V <sub>OL</sub>	Output logic low	RXC, TXH, RESETZ	0.4	V
C <sub>OUT</sub>	Output capacitance on OUTA	1	4	μF
	Output capacitance on OUTB	4	22	
C <sub>CPO</sub>	Output capacitance on CPO	2	10	nF
T <sub>A</sub>	Operating temperature range	–40	85	°C

## ELECTRICAL CHARACTERISTICS

Unless otherwise noted the specification applies over the  $V_{DD}$  range and operating junction temp  $-40^{\circ}\text{C} \leq T_J \leq 85^{\circ}\text{C}$ . Typical values are for  $V_{DD} = 3.3\text{V}$  and  $T_J = 25^{\circ}\text{C}$

PARAMETER	TEST CONDITIONS	MIN	TYP	MAX	UNIT		
<b>POWER SUPPLIES AND CURRENTS</b>							
$V_{DD1/2}$	Input voltage range	2.8		19.8	V		
$I_{DD-1}$	VDD1 Quiescent current	$V_{DD1} = 2.5$ to $15\text{V}$		250	500	$\mu\text{A}$	
$I_{DD-2}$	VDD2 Quiescent current	$V_{DD2} = 3.3\text{V}$ , $V_{DD1} = 3.3\text{V}$		20		$\mu\text{A}$	
		$V_{DD2} = 3.3\text{V}$ , $V_{DD1} = 15\text{V}$		20			
$I_{DDOFF-2}$	VDD2 Off current	$V_{DD2} = 3.3\text{V}$ , $V_{DD1} = 0\text{V}$			1	$\mu\text{A}$	
$I_{IN-ENB}$	ENB Input current	$V_{IN} = 1.8\text{V}$ to $3.6\text{V}$			1	$\mu\text{A}$	
$I_{IN-UART}$	RXH Input current	$V_{IN} = 1.8\text{V}$ to $3.6\text{V}$			1	$\mu\text{A}$	
$I_{IN-CFGOE}$	CFG/OE Input current <sup>(1)</sup>	$V_{CFG/OE} = 0\text{V}$		-1	-1.8	-5	$\mu\text{A}$
$V_{PUCFGOE}$	CFG/OE pull-up voltage <sup>(1)</sup>			2.3		6.7	V
$I_{IN-RESETZ}$	RESETZ Input current	$V_{RESETZ} = 100\text{mV}$		0.8	2	3	mA
<b>SWITCH AND RESISTANCE CHARACTERISTICS</b>							
$R_{F1}$	FET1 On resistance	$V_{DD} = 3.3\text{V}$ , $I_{OUT} = 10\text{mA}$			5	$\Omega$	
$R_{F2}$	FET2 On resistance				5		
$R_{F3}$	FET3 On resistance	$V_{DD} = 3.3\text{V}$ , $I_{OUT} = 350\text{mA}$			170	250	m $\Omega$
$R_{F4}$	FET4 On resistance				170	250	
$R_{PDRESETZ}$	RESETZ Pull-down resistance	RESETZ asserted		33	50	100	$\Omega$
$R_{PUCFGOE}$	CFG/OE Pull-up resistance <sup>(1)</sup>			1.2	2	2.6	M $\Omega$
$R_{PDUART}$	TXC Pull-down resistance	See the UART RX and TX Section		80	130	180	k $\Omega$
<b>VOLTAGE THRESHOLDS AND AMPLITUDES</b>							
$V_{HVLO}$	High voltage lockout	3.3V Supply rising		3.5	3.55	3.6	V
	Hysteresis			20	40	60	mV
$V_{UVLO}$	Under voltage lockout	3.3V Supply rising		2.7	2.75	2.8	V
		3.3V Supply falling		2.4	2.45	2.5	
$V_{CPO}$	Charge pump voltage	$C_{CPO} = 2\text{nF}$ , $I_{CPO} = 0\mu\text{A}$		7	8	9	V
$V_{OS}$	Voltage overshoot on OUTA/B	$C_{OUTB} = 4\mu\text{F}$ , $I_{OUTB} = 0\text{mA}$ , $C_{OUTA} = 1\mu\text{F}$ , $I_{OUTA} = 0\text{mA}$ $V_{DD1} SR_{3.3 \rightarrow 4V} = 10\text{mV}/\mu\text{s}$				200	mV

(1) CFG/OE is pulled up to  $V_{PUCFGOE}$  through the resistance  $R_{PUCFGOE}$ .

**ELECTRICAL CHARACTERISTICS (continued)**

Unless otherwise noted the specification applies over the  $V_{DD}$  range and operating junction temp  $-40^{\circ}\text{C} \leq T_J \leq 85^{\circ}\text{C}$ . Typical values are for  $V_{DD} = 3.3\text{V}$  and  $T_J = 25^{\circ}\text{C}$

PARAMETER	TEST CONDITIONS	MIN	TYP	MAX	UNIT	
<b>THERMAL SHUTDOWN</b>						
$T_{SD}$	Shutdown temperature	110		130	$^{\circ}\text{C}$	
$T_{SDHYST}$	Shutdown hysteresis		15		$^{\circ}\text{C}$	
<b>TRANSITION TIMING</b>						
$t_d$	UVLO to FETn open time			200	$\mu\text{s}$	
$t_e$	UVLO to FETn closed time	$C_{OUTB} = 4 \mu\text{F}$ , $C_{OUTA} = 1 \mu\text{F}$		2	ms	
$t_{dh}$	HVLO to FETn open time			20	$\mu\text{s}$	
$t_{eh}$	HVLO to FETn closed time	See The Supply Switch-Over During HVLO Section				
<b>TRANSITION TIMING (NORMAL MODE)</b>						
$t_{eb}$	ENB to FET3/4 closed time	$C_{OUTB} = 4 \mu\text{F}$ , $C_{OUTA} = 1 \mu\text{F}$		2	ms	
$t_{db}$	ENB to FET3/4 open time			200	$\mu\text{s}$	
<b>TRANSITION TIMING (CONTROL MODE)</b>						
$t_{U2R}$	UVLO to RESETZ time		5	6	7	ms
$t_{E2R}$	ENB to RESETZ time			2	10	$\mu\text{s}$
$t_{E2O}$	ENB to FET3/4 open time	$C_{OUTB} = 4 \mu\text{F}$ , $C_{OUTA} = 1 \mu\text{F}$		100	200	$\mu\text{s}$
$t_{RX2O}$	RX to FET3/4 closed time	$C_{OUTB} = 4 \mu\text{F}$ , $C_{OUTA} = 1 \mu\text{F}$		0.8	2	ms
$t_{RX2R}$	RX to RESETZ Time		5	6	7	ms
$t_{OE2TX}$	OE to TXH Valid Time				20	$\mu\text{s}$
$t_{OE2TXZ}$	OE to TXH Hi-Z Time				20	$\mu\text{s}$
<b>TXC/TXH I/O (CONTROL MODE)</b>						
$V_{IH}$	TXC Input logic high		2		V	
$V_{IL}$	TXC Input logic low			0.8	V	
$V_{OH}$	TXH Output logic high		2.25		V	
$V_{OL}$	TXH Output logic low			0.4	V	
$T_R / T_F$	TXH Rise and fall time	10-90% CL = 20 pF	5		70	ns
$Z_O$	TXH Output impedance			35	$\Omega$	
$f_{MAX}$	TX Input signal frequency				1	Mb/s
DC	TX Duty cycle		40%		60%	
<b>RXC/RXH I/O (CONTROL MODE)</b>						
$V_{IH}$	RXH Input logic high		2		V	
$V_{IL}$	RXH Input logic low			0.8	V	
$V_{OH}$	RXC Output logic high		2.25		V	
$V_{OL}$	RXC Output logic low			0.4	V	
$T_R / T_F$	RXC Rise and fall time	10-90% CL = 20 pF	20		120	ns
$f_{MAX}$	RX Input signal frequency				1	Mb/s
DC	RX Duty cycle		40%		60%	

FUNCTIONAL BLOCK DIAGRAM

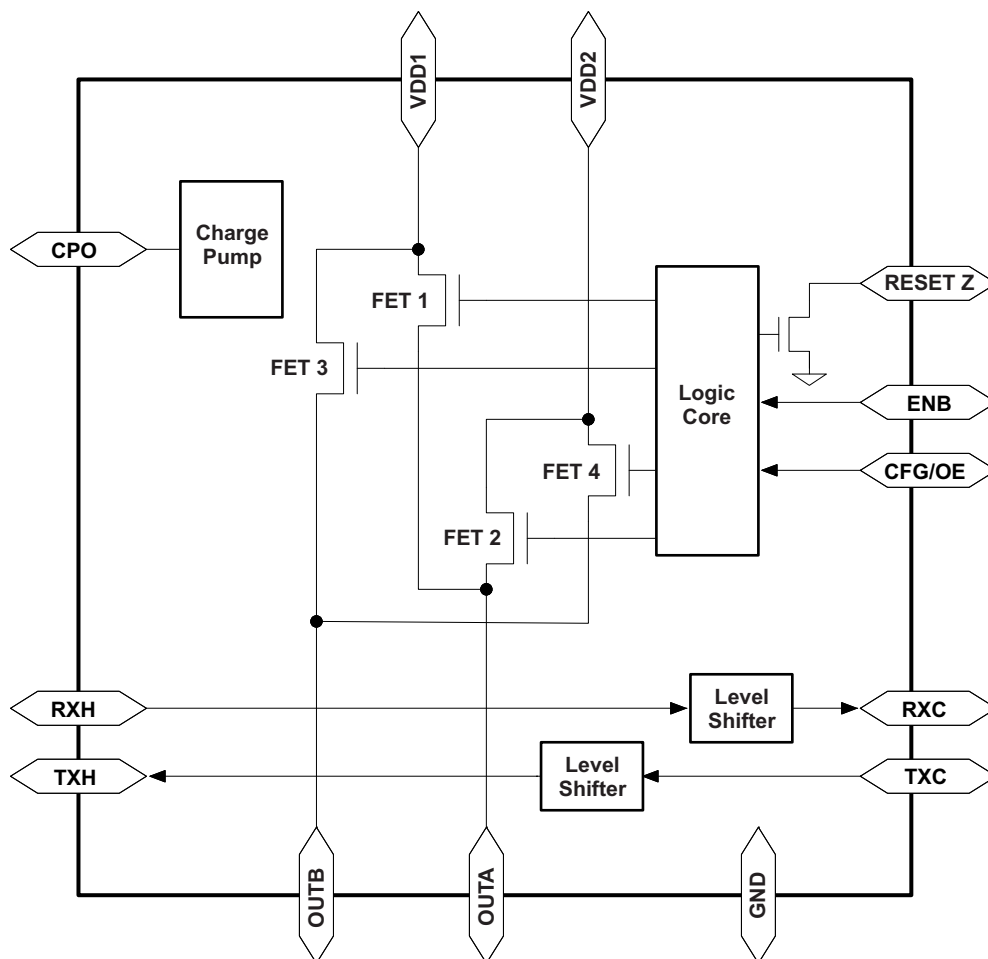

Figure 2. Functional Block Diagram

## DEVICE INFORMATION

### PIN FUNCTIONS

PIN NAME	TYPE	DESCRIPTION
VDD1	Supply	<b>Device Supply 1.</b> 0V to 19.8-V Input.
VDD2	Supply	<b>Device Supply 2.</b> 0V to 19.8-V Input.
OUTA	Output	<b>Output A.</b> 10-mA capable output. Refer to the <a href="#">Supply Selection</a> section for more information.
OUTB	Output	<b>Output B.</b> 500-mA capable output. Refer to the <a href="#">Normal Mode</a> and <a href="#">Control Mode</a> sections for more information.
CPO	Output	<b>Charge Pump Output.</b> This pin is the output of the internal charge pump. It drives the gates of the internal FET switches. Connect a capacitor of at least 2nF to this pin.
CFG/OE	Input	<b>Mode Configuration/Output Enable.</b> When CFG is floating, the device is in Normal Mode. When CFG is ground, the device is in Control Mode (see the <a href="#">APPLICATION INFORMATION</a> section for more information). The mode is latched at power-up. When the device enters Control Mode, this pin becomes an output enable for the UART TXH output. See the <a href="#">UART RX and TX</a> section for more information. A pull-down resistance between this pin and GND is recommended when Control Mode is desired.
RXH	Input	<b>UART RX Input.</b> Monitored Input for data activity to enable outputs. In Control Mode, this pin is monitored for a high to low transition to enable the outputs. This input is level shifted and driven on RXC. See the <a href="#">UART RX and TX</a> section for more information.
RXC	Output	<b>UART RX Output.</b> This output is a level shifted version of RXH. RXC is referenced to OUTA. See the <a href="#">UART RX and TX</a> section for more information.
TXC	Input	<b>UART TX Input.</b> This input is buffered and level shifted on TXH. See the <a href="#">UART RX and TX</a> section for more information.
TXH	Output	<b>UART TX Output.</b> This output is a buffered and level shifted version of TXC. TXH is referenced to OUTA. See the <a href="#">UART RX and TX</a> section for more information.
RESETZ	Output	<b>Microcontroller Reset.</b> This pin is a delayed reset signal indicating OUTB is connected to a valid VDD. RESETZ in an open-drain pull-down. RESETZ is low when OUTB is high impedance.
ENB	Input	<b>OUTB Enable.</b> In Normal Mode, this pin is the active high OUTB enable. In Control Mode, this pin opens OUTB when asserted high and resets the device until a new transition on RX occurs.
GND	Supply	<b>Device ground.</b>

APPLICATION INFORMATION

Supply Selection

The TPS22985 selects between two separate power supplies, VDD1 or VDD2, and connects these to two outputs (OUTA and OUTB) through non-current limited switches. When a valid VDD ( $V_{UVLO} < VDD < V_{HVLO}$ ) is present on VDD1, VDD1 will be connected to the outputs. When  $VDD1 > V_{HVLO}$ , the TPS22985 will connect the outputs to VDD2 when a valid VDD is present on this input. OUTB is also opened and closed by other digital inputs, ENB and RXH, depending on the mode of the TPS22985. Refer to the [Normal Mode](#) and [Control Mode](#) sections for more information on the control of OUTB. VDD1 and VDD2 can power up in any order; however, VDD1 always takes priority over VDD2 and only allows VDD2 to connect when the  $VDD1 > V_{HVLO}$  condition is present. When the outputs are connected to VDD2, and VDD1 drops below  $V_{HVLO}$ , the TPS22985 will disconnect the outputs from VDD2. Figure 3 shows a flow diagram illustrating the selection of VDD1 or VDD2 as the appropriate supply to connect to OUTA and OUTB. Note, this diagram does not show the enabling and disabling of OUTB by ENB and RXH.

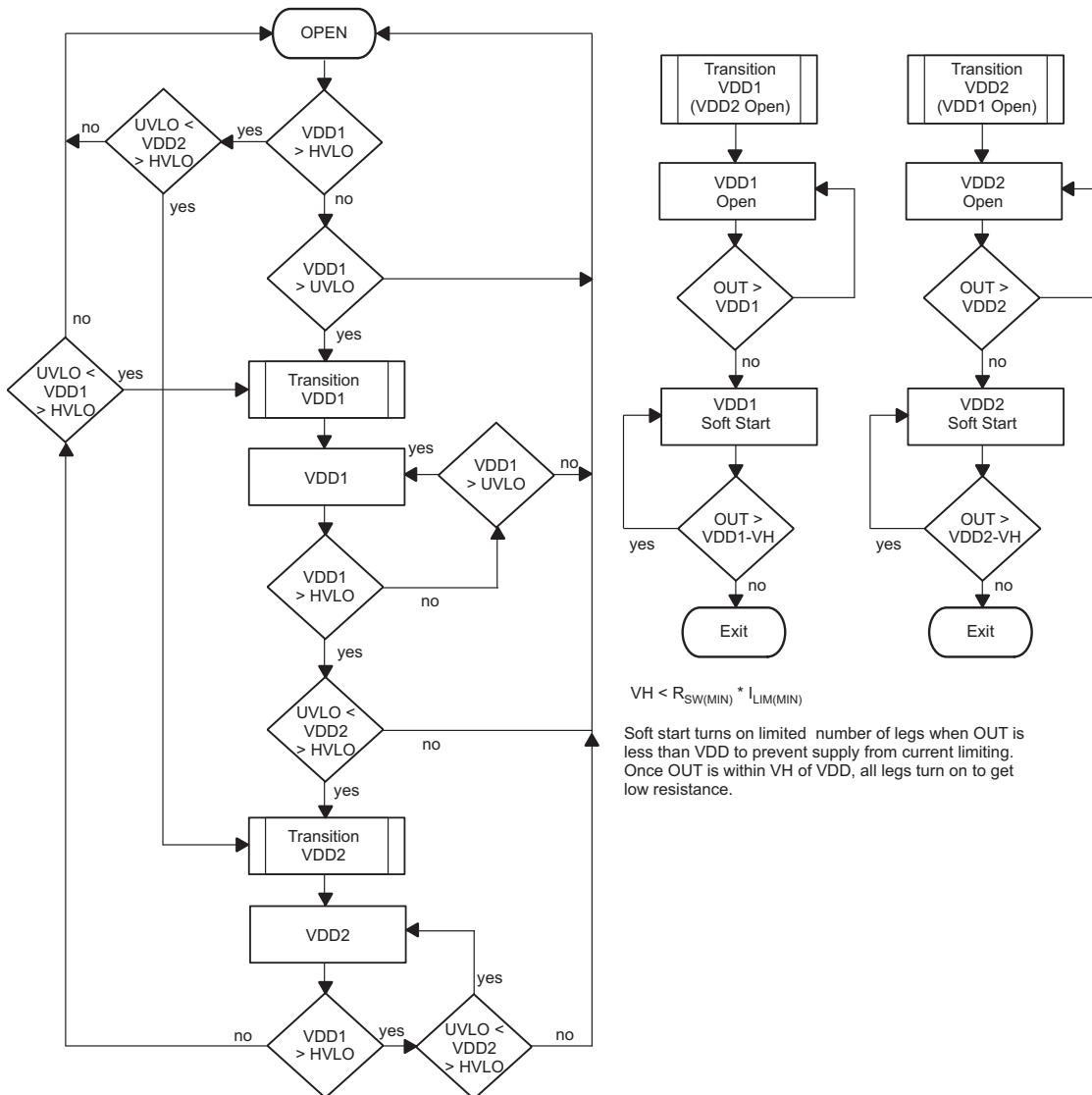

Figure 3. Flow Diagram of Supply Selection and Switch-Over

**Normal Mode**

When the CFG/OE pin is floating at power-up, the device enters Normal Mode. In Normal Mode, the TPS22985 provides power via OUTA and OUTB.

OUTA is connected whenever a valid VDD is present on VDD1. OUTA may also be connected if  $VDD1 > V_{HVLO}$  and a valid VDD is connected to VDD2. OUTB is connected whenever a valid VDD is present on VDD1. OUTB may also be connected if  $VDD1 > V_{HVLO}$ , a valid VDD is connected to VDD2, and the control signal ENB is high. When OUTB is connected it will supply  $\geq 500$  mA to a load.

When a valid VDD is not present, the TPS22985 enters into a shutdown mode and blocks current flow through the switches.

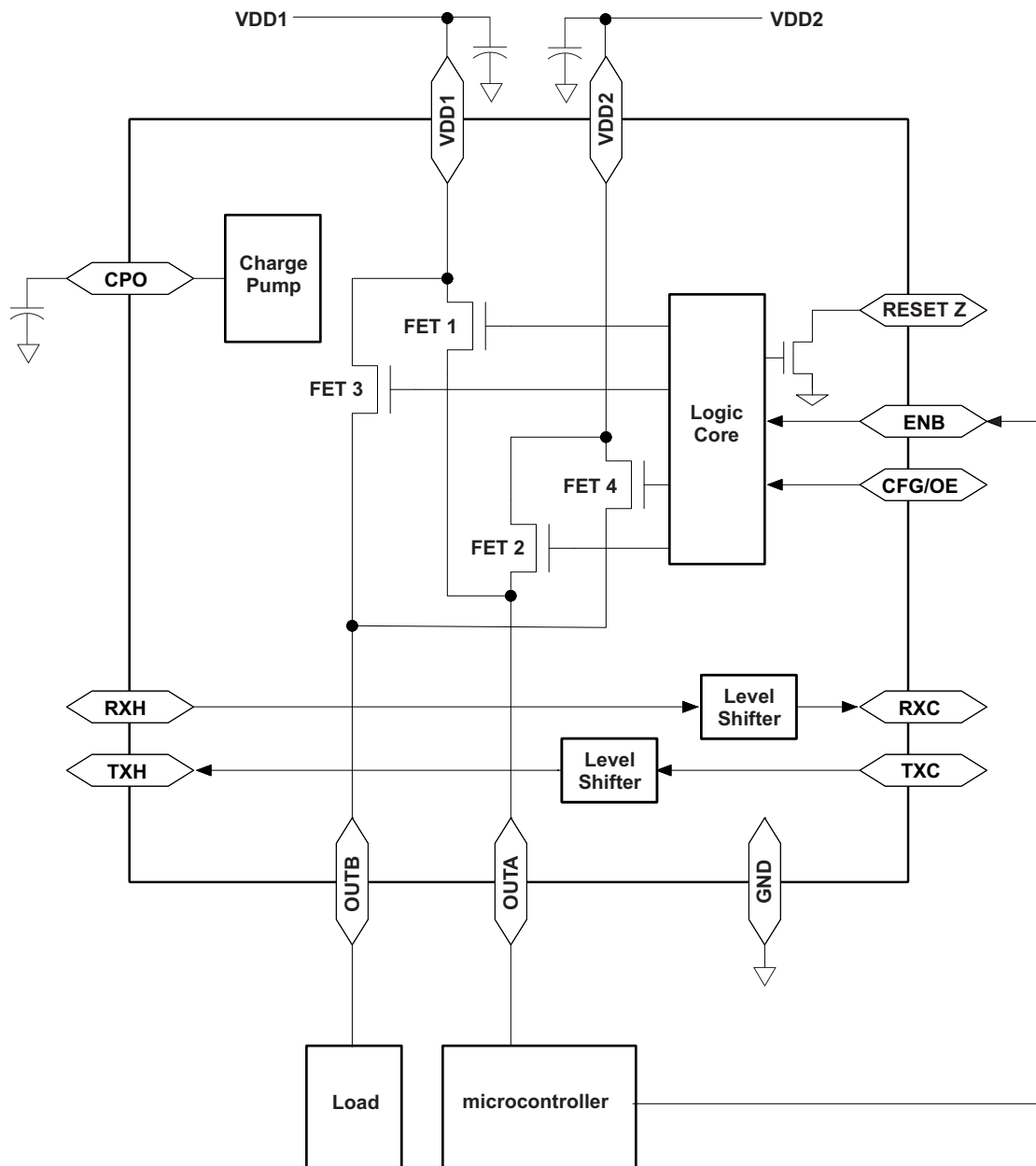

**Figure 4. Normal Mode Typical Application**

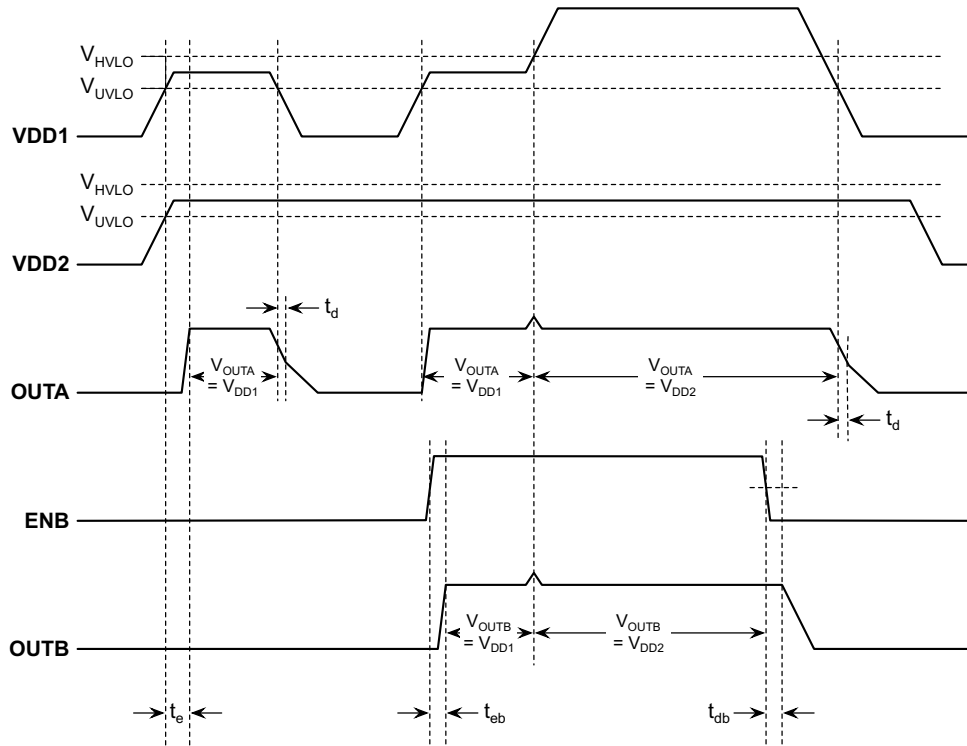

Figure 5. Timing During Normal Mode



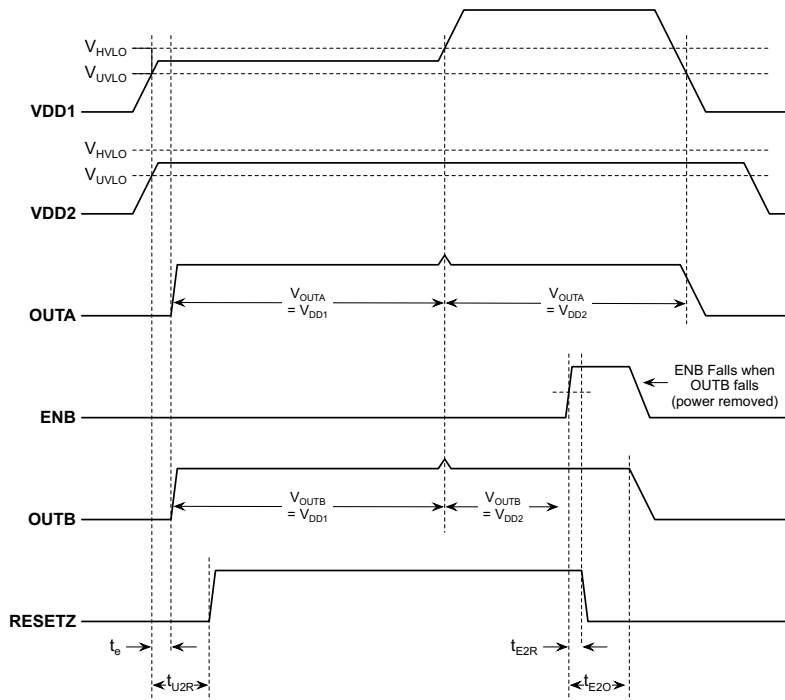

Figure 7. Timing During Control Mode

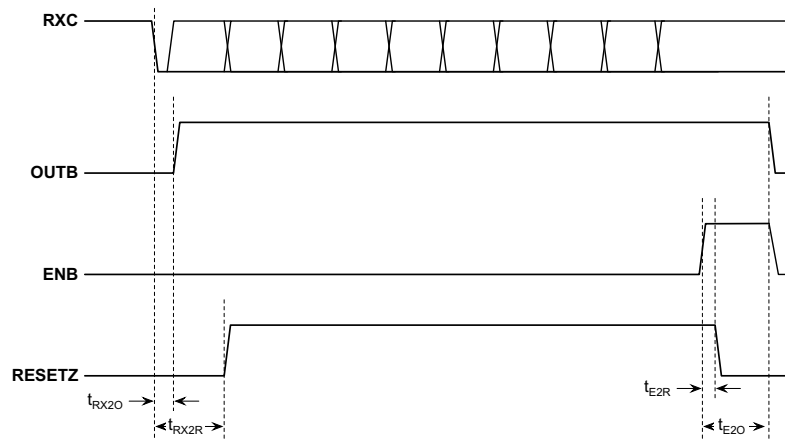

Figure 8. Timing During Control Mode Continued

Typical Startup

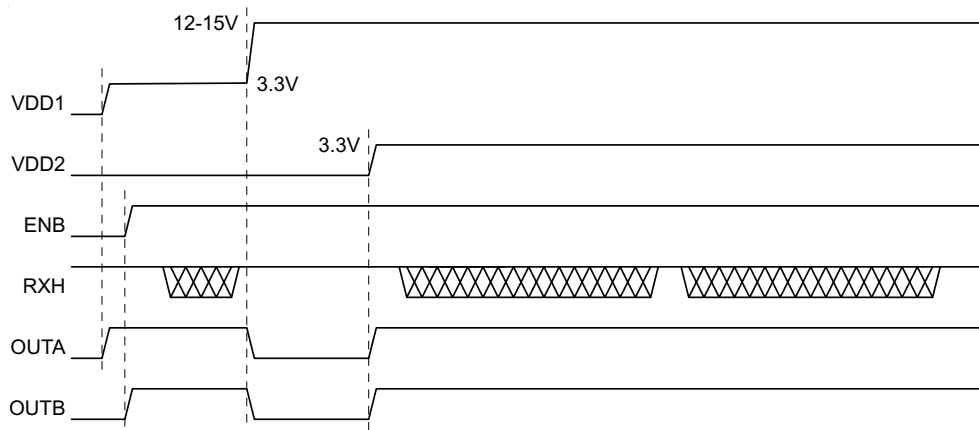

Figure 9. Typical Startup in Normal Mode

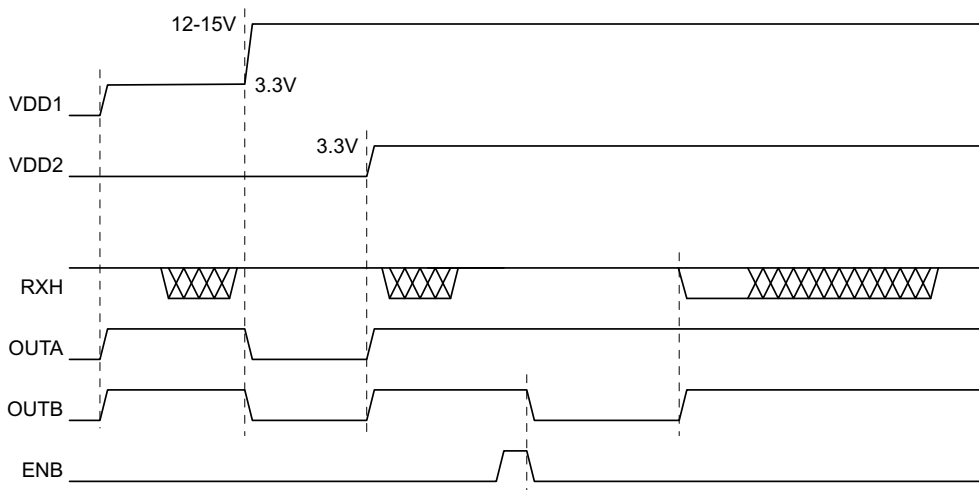

Figure 10. Typical Startup Timing for Control Mode

Figure 10. Typical Startup Timing for Control Mode

## Soft Start

To prevent inrush current to the load, the TPS22985 soft starts OUTA and OUTB. When OUTA and OUTB are first enabled, the resistance of the FET switches (FET1, FET2, FET3, and FET4) starts high and reduces every 250 $\mu$ s in four steps. Figure 11 shows the nominal resistance ramp profile for OUTB. The resistance shown in this figure is the equivalent resistance through FET3 and FET4 in Figure 2.

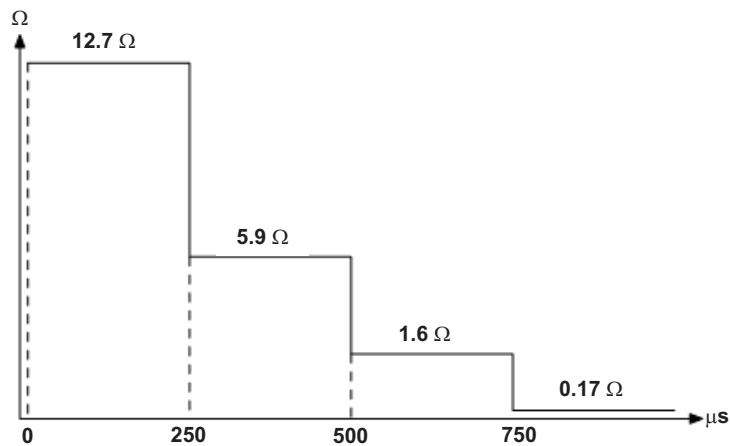

Figure 11. OUTB Soft Start Resistance vs Time Profile

## Supply Switch-Over During HVLO

When OUTA and OUTB are connected to VDD1 and VDD1 crosses  $V_{HVLO}$ , the TPS22985 will open the FET1/3 switches. Due to the delay  $t_{dh}$ , the output will overshoot  $V_{HVLO}$  by  $V_{OS}$ . When a valid VDD is present on VDD2, OUTA and OUTB will connect to VDD2 after time  $t_{eh}$ . Figure 12 illustrates this switch-over event.

The overshoot  $V_{OS}$  will occur when the VDD (VDD1 or VDD2) that is connected to the output transitions above  $V_{HVLO}$ .  $V_{OS}$  is set by the delay  $t_{dh}$  and the slew rate of the connected VDD. However, the connection of the outputs to VDD2 will only occur when VDD1 transitions above  $V_{HVLO}$  and VDD2 is a valid VDD.

The following equation determines the overshoot  $V_{OS}$ .

$$V_{OS} = SR_{VDD} \times t_{DH} \quad (1)$$

$SR_{VDD}$  is the slew rate of the supply that is transitioning above  $V_{HVLO}$ . As an example, when  $SR_{VDD}$  is 10mV/ $\mu$ s and  $t_{dh}$  is 20 $\mu$ s,  $V_{OS}$  is 200mV.

When switching to VDD2 due to an HVLO event on VDD1, the outputs OUTA and OUTB are discharged by their respective loads until they reach the VDD2 voltage. This prevents in-rush current when charging the output caps. The discharge time  $t_{eh}$  is variable and is determined by the following equation.

$$t_{eh} = t_{dh} + (V_{HVLO} + V_{OS} - V_{DD2}) \times C_{LOAD}/I_{LOAD} \quad (2)$$

In this equation,  $V_{OS}$  is determined by Equation 1,  $C_{LOAD}$  is the load capacitance at the respective output, and  $I_{LOAD}$  is load current flowing out of the same output. As an example, when VDD2 is 3.3V,  $t_{dh}$  is 20 $\mu$ s,  $V_{OS}$  is 200mV,  $C_{LOAD}$  is 4 $\mu$ F, and  $I_{LOAD}$  is 350mA, the resulting  $t_{eh}$  is 25.7 $\mu$ s.

Note, when VDD1 transitions above  $V_{HVLO}$  and a valid VDD is not present on VDD2, the outputs will open and will discharge through each respective load.

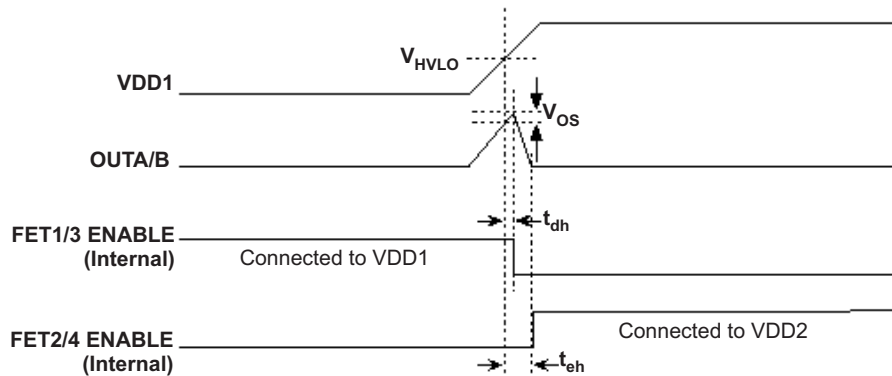

Figure 12. VDD switch-over at VDD1 rising above  $V_{HVLO}$

### UART RX and TX

The TPS22985 provides failsafe buffers for digital UART RX and TX lines. The failsafe mechanism prevents the RX and TX lines from being loaded when power is removed from the device. The RX line is divided into a host side RXH input and a cable side RXC output. The TX line is divided into host side TXH output and a cable side TXC input.

The RXH and TXC inputs are used in Control Mode only and must be pulled low when the device is in Normal Mode. In Normal Mode, leave the RXH and TXC pins disconnected from the UART signal lines and pull low through a > 1kΩ resistance.

In Control Mode, when the TPS22985 is unpowered or when RESETZ is asserted low, the TXH output is high impedance. This prevents loading the system TX line and allowing other devices on the UART bus to communicate. The RXC output is pulled low through the output driver during this same condition.

Figure 13 illustrates the RXC and TXH control when in Control Mode. When RESETZ is high, CFG/OE controls TXH. When CFG/OE is low, TXH is high impedance. When CFG/OE is high, TXH is a buffered and level-shifted TXC. The CFG/OE, ENB, and TXC inputs are ignored when RESETZ is asserted low. Figure 14 shows the delay from CFG/OE to TXH.

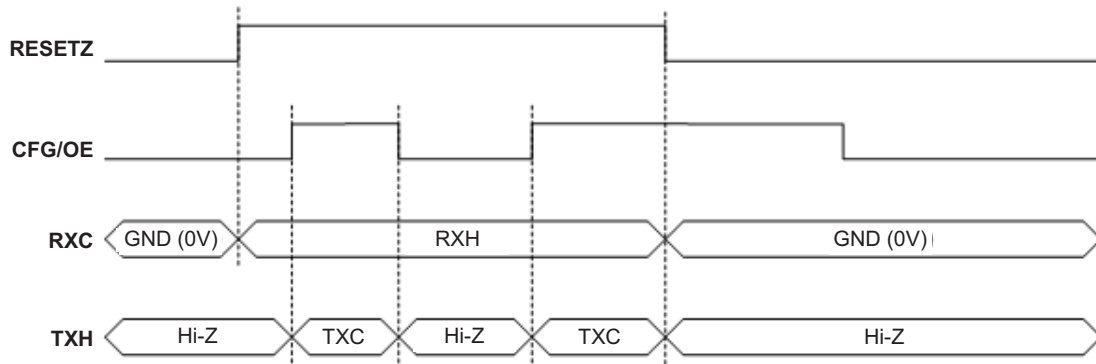

Figure 13. UART RX and TX Buffer Control During Control Mode

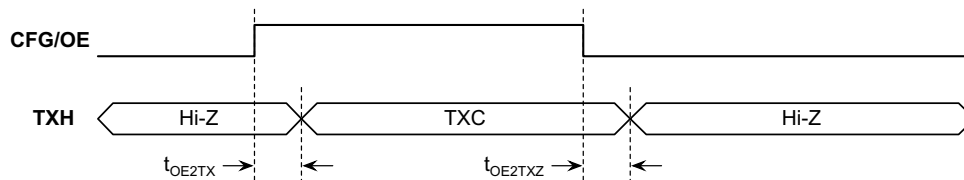

Figure 14. CFG/OE to TXH Timing During Control Mode

THUNDERBOLT™ SYSTEM WITH TPS22980/TPS22985

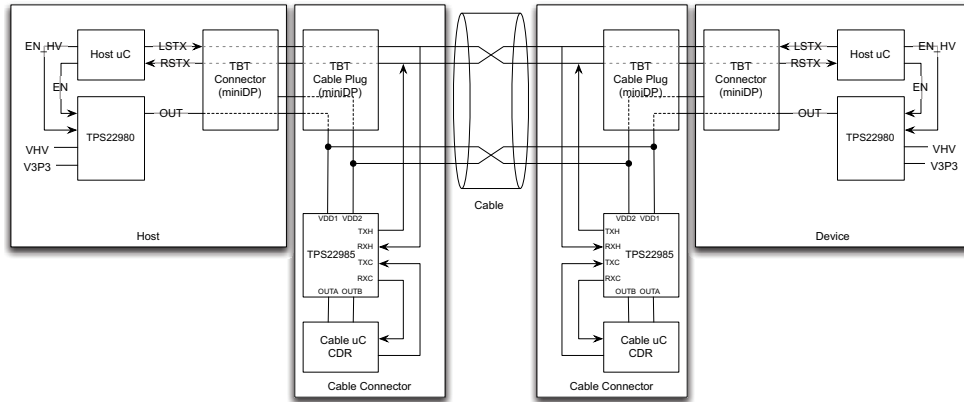

Figure 15. Thunderbolt System with TPS22980/TPS22985

**PACKAGING INFORMATION**

Orderable Device	Status (1)	Package Type	Package Drawing	Pins	Package Qty	Eco Plan (2)	Lead/Ball Finish (6)	MSL Peak Temp (3)	Op Temp (°C)	Device Marking (4/5)	Samples
TPS22985YFPR	NRND	DSBGA	YFP	16	3000	Green (RoHS & no Sb/Br)	SNAGCU	Level-1-260C-UNLIM	-40 to 85	9U	

(1) The marketing status values are defined as follows:

**ACTIVE:** Product device recommended for new designs.

**LIFEBUY:** TI has announced that the device will be discontinued, and a lifetime-buy period is in effect.

**NRND:** Not recommended for new designs. Device is in production to support existing customers, but TI does not recommend using this part in a new design.

**PREVIEW:** Device has been announced but is not in production. Samples may or may not be available.

**OBSELETE:** TI has discontinued the production of the device.

(2) Eco Plan - The planned eco-friendly classification: Pb-Free (RoHS), Pb-Free (RoHS Exempt), or Green (RoHS & no Sb/Br) - please check <http://www.ti.com/productcontent> for the latest availability information and additional product content details.

**TBD:** The Pb-Free/Green conversion plan has not been defined.

**Pb-Free (RoHS):** TI's terms "Lead-Free" or "Pb-Free" mean semiconductor products that are compatible with the current RoHS requirements for all 6 substances, including the requirement that lead not exceed 0.1% by weight in homogeneous materials. Where designed to be soldered at high temperatures, TI Pb-Free products are suitable for use in specified lead-free processes.

**Pb-Free (RoHS Exempt):** This component has a RoHS exemption for either 1) lead-based flip-chip solder bumps used between the die and package, or 2) lead-based die adhesive used between the die and leadframe. The component is otherwise considered Pb-Free (RoHS compatible) as defined above.

**Green (RoHS & no Sb/Br):** TI defines "Green" to mean Pb-Free (RoHS compatible), and free of Bromine (Br) and Antimony (Sb) based flame retardants (Br or Sb do not exceed 0.1% by weight in homogeneous material)

(3) MSL, Peak Temp. - The Moisture Sensitivity Level rating according to the JEDEC industry standard classifications, and peak solder temperature.

(4) There may be additional marking, which relates to the logo, the lot trace code information, or the environmental category on the device.

(5) Multiple Device Markings will be inside parentheses. Only one Device Marking contained in parentheses and separated by a "~" will appear on a device. If a line is indented then it is a continuation of the previous line and the two combined represent the entire Device Marking for that device.

(6) Lead/Ball Finish - Orderable Devices may have multiple material finish options. Finish options are separated by a vertical ruled line. Lead/Ball Finish values may wrap to two lines if the finish value exceeds the maximum column width.

**Important Information and Disclaimer:**The information provided on this page represents TI's knowledge and belief as of the date that it is provided. TI bases its knowledge and belief on information provided by third parties, and makes no representation or warranty as to the accuracy of such information. Efforts are underway to better integrate information from third parties. TI has taken and continues to take reasonable steps to provide representative and accurate information but may not have conducted destructive testing or chemical analysis on incoming materials and chemicals. TI and TI suppliers consider certain information to be proprietary, and thus CAS numbers and other limited information may not be available for release.

In no event shall TI's liability arising out of such information exceed the total purchase price of the TI part(s) at issue in this document sold by TI to Customer on an annual basis.



**TAPE AND REEL INFORMATION**

**QUADRANT ASSIGNMENTS FOR PIN 1 ORIENTATION IN TAPE**

\*All dimensions are nominal

Device	Package Type	Package Drawing	Pins	SPQ	Reel Diameter (mm)	Reel Width W1 (mm)	A0 (mm)	B0 (mm)	K0 (mm)	P1 (mm)	W (mm)	Pin1 Quadrant
TPS22985YFPR	DSBGA	YFP	16	3000	180.0	8.4	1.71	1.71	0.81	4.0	8.0	Q1

**TAPE AND REEL BOX DIMENSIONS**

\*All dimensions are nominal

Device	Package Type	Package Drawing	Pins	SPQ	Length (mm)	Width (mm)	Height (mm)
TPS22985YFPR	DSBGA	YFP	16	3000	182.0	182.0	20.0

## IMPORTANT NOTICE

Texas Instruments Incorporated (TI) reserves the right to make corrections, enhancements, improvements and other changes to its semiconductor products and services per JESD46, latest issue, and to discontinue any product or service per JESD48, latest issue. Buyers should obtain the latest relevant information before placing orders and should verify that such information is current and complete.

TI's published terms of sale for semiconductor products (<http://www.ti.com/sc/docs/stdterms.htm>) apply to the sale of packaged integrated circuit products that TI has qualified and released to market. Additional terms may apply to the use or sale of other types of TI products and services.

Reproduction of significant portions of TI information in TI data sheets is permissible only if reproduction is without alteration and is accompanied by all associated warranties, conditions, limitations, and notices. TI is not responsible or liable for such reproduced documentation. Information of third parties may be subject to additional restrictions. Resale of TI products or services with statements different from or beyond the parameters stated by TI for that product or service voids all express and any implied warranties for the associated TI product or service and is an unfair and deceptive business practice. TI is not responsible or liable for any such statements.

Buyers and others who are developing systems that incorporate TI products (collectively, "Designers") understand and agree that Designers remain responsible for using their independent analysis, evaluation and judgment in designing their applications and that Designers have full and exclusive responsibility to assure the safety of Designers' applications and compliance of their applications (and of all TI products used in or for Designers' applications) with all applicable regulations, laws and other applicable requirements. Designer represents that, with respect to their applications, Designer has all the necessary expertise to create and implement safeguards that (1) anticipate dangerous consequences of failures, (2) monitor failures and their consequences, and (3) lessen the likelihood of failures that might cause harm and take appropriate actions. Designer agrees that prior to using or distributing any applications that include TI products, Designer will thoroughly test such applications and the functionality of such TI products as used in such applications.

TI's provision of technical, application or other design advice, quality characterization, reliability data or other services or information, including, but not limited to, reference designs and materials relating to evaluation modules, (collectively, "TI Resources") are intended to assist designers who are developing applications that incorporate TI products; by downloading, accessing or using TI Resources in any way, Designer (individually or, if Designer is acting on behalf of a company, Designer's company) agrees to use any particular TI Resource solely for this purpose and subject to the terms of this Notice.

TI's provision of TI Resources does not expand or otherwise alter TI's applicable published warranties or warranty disclaimers for TI products, and no additional obligations or liabilities arise from TI providing such TI Resources. TI reserves the right to make corrections, enhancements, improvements and other changes to its TI Resources. TI has not conducted any testing other than that specifically described in the published documentation for a particular TI Resource.

Designer is authorized to use, copy and modify any individual TI Resource only in connection with the development of applications that include the TI product(s) identified in such TI Resource. NO OTHER LICENSE, EXPRESS OR IMPLIED, BY ESTOPPEL OR OTHERWISE TO ANY OTHER TI INTELLECTUAL PROPERTY RIGHT, AND NO LICENSE TO ANY TECHNOLOGY OR INTELLECTUAL PROPERTY RIGHT OF TI OR ANY THIRD PARTY IS GRANTED HEREIN, including but not limited to any patent right, copyright, mask work right, or other intellectual property right relating to any combination, machine, or process in which TI products or services are used. Information regarding or referencing third-party products or services does not constitute a license to use such products or services, or a warranty or endorsement thereof. Use of TI Resources may require a license from a third party under the patents or other intellectual property of the third party, or a license from TI under the patents or other intellectual property of TI.

TI RESOURCES ARE PROVIDED "AS IS" AND WITH ALL FAULTS. TI DISCLAIMS ALL OTHER WARRANTIES OR REPRESENTATIONS, EXPRESS OR IMPLIED, REGARDING RESOURCES OR USE THEREOF, INCLUDING BUT NOT LIMITED TO ACCURACY OR COMPLETENESS, TITLE, ANY EPIDEMIC FAILURE WARRANTY AND ANY IMPLIED WARRANTIES OF MERCHANTABILITY, FITNESS FOR A PARTICULAR PURPOSE, AND NON-INFRINGEMENT OF ANY THIRD PARTY INTELLECTUAL PROPERTY RIGHTS. TI SHALL NOT BE LIABLE FOR AND SHALL NOT DEFEND OR INDEMNIFY DESIGNER AGAINST ANY CLAIM, INCLUDING BUT NOT LIMITED TO ANY INFRINGEMENT CLAIM THAT RELATES TO OR IS BASED ON ANY COMBINATION OF PRODUCTS EVEN IF DESCRIBED IN TI RESOURCES OR OTHERWISE. IN NO EVENT SHALL TI BE LIABLE FOR ANY ACTUAL, DIRECT, SPECIAL, COLLATERAL, INDIRECT, PUNITIVE, INCIDENTAL, CONSEQUENTIAL OR EXEMPLARY DAMAGES IN CONNECTION WITH OR ARISING OUT OF TI RESOURCES OR USE THEREOF, AND REGARDLESS OF WHETHER TI HAS BEEN ADVISED OF THE POSSIBILITY OF SUCH DAMAGES.

Unless TI has explicitly designated an individual product as meeting the requirements of a particular industry standard (e.g., ISO/TS 16949 and ISO 26262), TI is not responsible for any failure to meet such industry standard requirements.

Where TI specifically promotes products as facilitating functional safety or as compliant with industry functional safety standards, such products are intended to help enable customers to design and create their own applications that meet applicable functional safety standards and requirements. Using products in an application does not by itself establish any safety features in the application. Designers must ensure compliance with safety-related requirements and standards applicable to their applications. Designer may not use any TI products in life-critical medical equipment unless authorized officers of the parties have executed a special contract specifically governing such use. Life-critical medical equipment is medical equipment where failure of such equipment would cause serious bodily injury or death (e.g., life support, pacemakers, defibrillators, heart pumps, neurostimulators, and implantables). Such equipment includes, without limitation, all medical devices identified by the U.S. Food and Drug Administration as Class III devices and equivalent classifications outside the U.S.

TI may expressly designate certain products as completing a particular qualification (e.g., Q100, Military Grade, or Enhanced Product). Designers agree that it has the necessary expertise to select the product with the appropriate qualification designation for their applications and that proper product selection is at Designers' own risk. Designers are solely responsible for compliance with all legal and regulatory requirements in connection with such selection.

Designer will fully indemnify TI and its representatives against any damages, costs, losses, and/or liabilities arising out of Designer's non-compliance with the terms and provisions of this Notice.

## Looking for pricing, stock, or lifecycle information?

Click below to explore more details on WIN SOURCE:

 [View TPS22985YFPR on WIN SOURCE](#)

 [Texas Instruments](#) Information

## Optimize Your Supply Chain with WIN SOURCE Solutions

-  Global Sourcing Solution
-  Obsolete Management
-  Cost Control Management
-  Shortage Management
-  Alternative Solution
-  Excess Inventory Management