



**THE DATASHEET OF
P2782AF-08SR**





General Purpose EMI Reduction IC

Features

- Provides up to 15dB of EMI suppression
- FCC approved method of EMI attenuation
- Generates a 1X, 2X, and 4X low EMI spread spectrum clock of the input frequency
- Input frequency range from 3 to 78MHz
- External loop filter for spread % adjustment
- Spreading ranges from $\pm 0.25\%$ to $\pm 5.0\%$
- Ultra low cycle-to-cycle jitter
- Zero-cycle slip
- 3.3V operating voltage range
- Ultra-low power CMOS design
- P278xA is available in an 8 pin SOIC Package

Product Description

The P278xA is a versatile spread spectrum frequency modulator designed specifically for digital camera and other digital video and imaging applications. The P278xA reduces electromagnetic interference (EMI) at the clock

source, which provides system wide reduction of EMI of all clock dependent signals. The P278xA allows significant system cost savings by reducing the number of circuit board layers and shielding that are traditionally required to pass EMI regulations.

The P278xA uses the most efficient and optimized modulation profile approved by the FCC. The P278xA modulates the output of a single PLL in order to “spread” the bandwidth of a synthesized clock and, more importantly, decreases the peak amplitudes of its harmonics. This result in significantly lower system EMI compared to the typical narrow band signal produced by oscillators and most frequency generators. Lowering EMI by increasing a signal’s bandwidth is called spread spectrum clock generation.

Applications

The P278xA is targeted towards MFP, xDSL, fax modem, set-top box, USB controller, DSC, and embedded systems.

Block Diagram

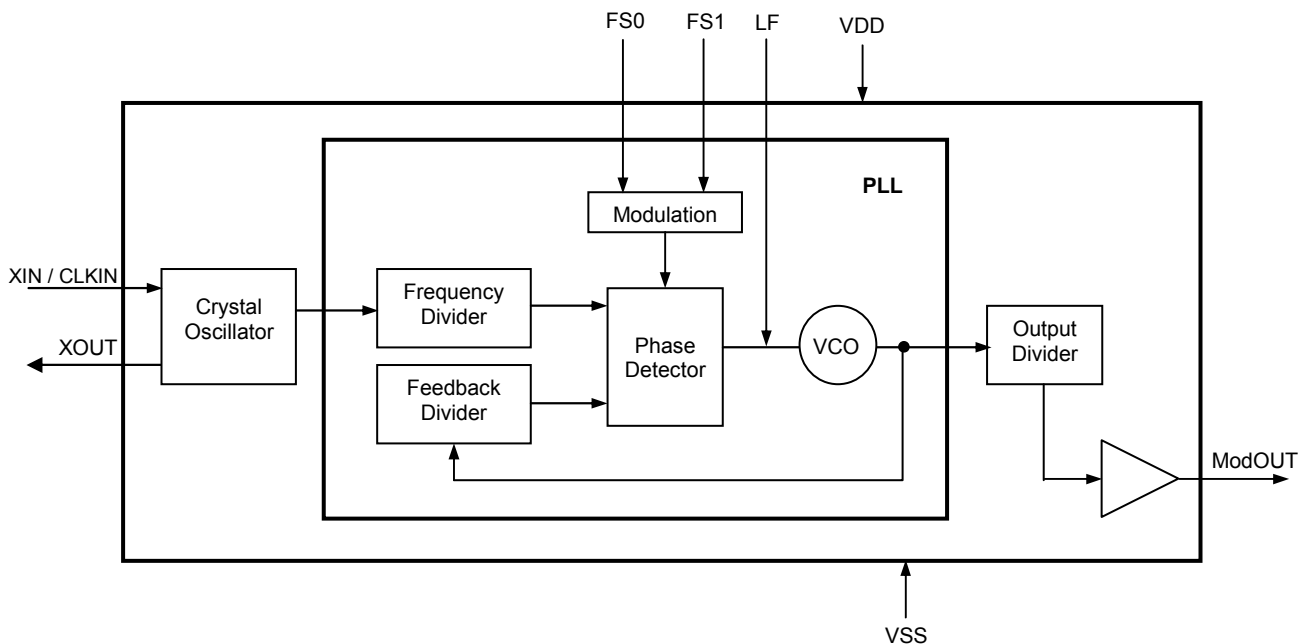

Pin Configuration

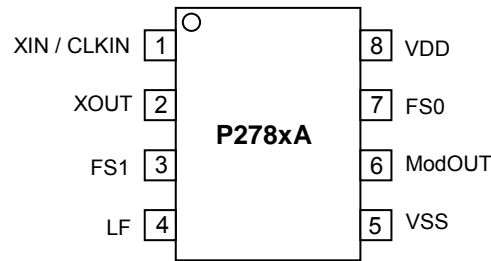

Standard pin Configuration offered in both 8 pin SOIC Packages.

Pin Description (P278xA)

Pin#	Pin Name	Type	Description
1	XIN/CLKIN	I	Connect to crystal or clock input. This pin has dual functions. It can be connected either to an external crystal or an external reference clock.
2	XOUT	O	Crystal connection. If using an external reference, this pin must be left unconnected.
3	FS1	I	Digital logic input used to select input frequency range (see the <i>Input Frequency Selection Table</i>). This pin has an internal pull-up resistor.
4	LF	I	External Loop Filter for the PLL. By changing the value of the CRC circuit, the percentage spread can be adjusted accordingly. See the <i>Loop Filter Selection Table</i> for detail value.
5	VSS	I	Ground Connection. Connect to system ground.
6	ModOUT	O	Spread Spectrum Clock Output.
7	FS0	I	Digital logic input used to select input frequency range (see the <i>Input Frequency Selection Table</i>). This pin has an internal pull-up resistor.
8	VDD	P	Connect to +3.3 V

Input Frequency Selection Table

FS1	FS0	Input (MHz)	Output Frequency Scaling (MHz)			Modulation Rate (KHz)
			P2781A	P2782A	P2784A	
0	0	3 to 9	3 to 9	6 to 18	12 to 36	Fin / 128
0	1	10 to 19	10 to 19	20 to 38	40 to 76	Fin / 256
1	0	20 to 38	20 to 38	40 to 76	80 to 152	Fin / 512
1	1	39 to 78	39 to 78	78 to 156	156 to 312	Fin / 1024

Loop Filter Selection Table VDD 3.3V

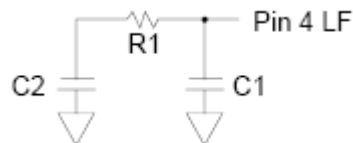

Contact ON Semiconductor for loop values that are not listed in the table and for Component selection values for industrial and automotive temperatures.

Input MHz	FS1	FS0	BW = ±0.50% ¹			BW = ±0.75% ¹			BW = ±1.00% ¹			BW = ±1.25% ¹		
			C1 (pF)	C2 (pF)	R1 (ohm)	C1 (pF)	C2 (pF)	R1 (ohm)	C1 (pF)	C2 (pF)	R1 (ohm)	C1 (pF)	C2 (pF)	R1 (ohm)
3	0	0	270	330,000	220	270	330,000	300	270	100,000	390	560	100,000	510
4	0	0	270	100,000	270	270	100,000	390	270	100,000	560	560	100,000	680
5	0	0	270	100,000	390	270	100,000	560	270	100,000	750	560	100,000	910
6	0	0	270	100,000	510	270	100,000	750	270	10,000	1,000	680	6,800	1,200
7	0	0	270	100,000	620	270	100,000	1,000	270	5,600	1,200	330	3,300	1,200
8	0	0	270	100,000	820	270	100,000	1,200	270	12,000	2,200	680	6,800	2,200
9	0	0	270	100,000	1,000	270	100,000	1,500	270	5,600	2,200	270	2,700	2,200
10	0	1	270	100,000	330	270	100,000	510	270	100,000	750	560	100,000	910
11	0	1	270	100,000	390	270	100,000	560	270	100,000	866(1%)	560	100,000	1,100
12	0	1	270	100,000	510	270	100,000	750	270	10,000	1,000	680	6,800	1,200
13	0	1	270	100,000	560	270	100,000	820	270	12,000	1,200	470	4,700	1,200
14	0	1	270	100,000	620	270	100,000	1,000	270	5,600	1,200	330	3,300	1,200
15	0	1	270	100,000	750	270	100,000	1,100	270	3,900	1,200	330	3,300	1,500
16	0	1	270	100,000	820	270	100,000	1,200	270	12,000	2,200	680	6,800	2,200
17	0	1	270	100,000	910	270	100,000	1,300	270	10,000	2,200	390	3,900	2,200
18	0	1	270	100,000	1,000	270	100,000	1,500	270	5,600	2,200	270	2,700	2,200
19	0	1	270	100,000	1,200	270	100,000	1,600	270	3,300	2,200	270	2,700	2,700
20	0	0	270	100,000	330	270	100,000	560	270	100,000	750	560	100,000	910
21-22	1	0	270	100,000	390	270	100,000	620	270	100,000	866 (1%)	560	100,000	1,100
23-24	1	0	270	100,000	510	270	100,000	750	270	10,000	1,000	680	6,800	1,200
25-26	1	0	270	100,000	560	270	100,000	820	270	12,000	1,200	470	4,700	1,200
27-28	1	0	270	100,000	620	270	100,000	1,000	270	6,800	1,200	330	3,300	1,200
29-30	1	0	270	100,000	750	270	100,000	1,100	270	3,900	1,200	330	3,300	1,500
31-32	1	0	270	100,000	820	270	100,000	1,200	270	12,000	2,200	680	6,800	2,200
33-34	1	0	270	100,000	910	270	100,000	1,300	270	10,000	2,200	390	3,900	2,200
35-36	1	0	270	100,000	1,000	270	100,000	1,500	270	5,600	2,200	270	2,700	2,200
37-38	1	0	270	100,000	1,200	270	100,000	1,600	270	3,300	2,200	270	2,700	2,700
39-42	1	1	270	100,000	330	270	100,000	560	270	100,000	750	560	100,000	910
43-46	1	1	270	100,000	390	270	100,000	620	270	100,000	866 (1%)	560	100,000	1,100
47-50	1	1	270	100,000	510	270	100,000	750	270	10,000	1,000	680	6,800	1,200
51-54	1	1	270	100,000	560	270	100,000	820	270	12,000	1,200	470	4,700	1,200
55-58	1	1	270	100,000	620	270	100,000	1,000	270	6,800	1,200	330	3,300	1,200
59-62	1	1	270	100,000	750	270	100,000	1,100	270	3,900	1,200	330	3,300	1,500
63-66	1	1	270	100,000	820	270	100,000	1,200	270	12,000	2,200	680	6,800	2,200
67-70	1	1	270	100,000	910	270	100,000	1,300	270	8,200	2,200	390	3,900	2,200
71-74	1	1	270	100,000	1,000	270	100,000	1,600	270	5,600	2,200	270	2,700	2,200
75-78	1	1	270	100,000	1,200	270	100,000	1,800	270	3,300	2,200	270	2,700	2,700

Note: 1. The BW value is representative of typical conditions.

Spread Spectrum Selection

The P278xA performs Zero Cycle Slip when set at low percentage spreading. This allows no occurrence of system timing error. The optimal setting should minimize system EMI to the fullest without affecting system performance. The spreading is described as a percentage deviation of the center frequency.

(Note: the center frequency is the frequency of the external reference input on CLKIN, Pin 1.)

The P2781A is designed for PC peripheral, networking, notebook PC, and LCD monitor applications. It is optimized for operation between 3 to 78MHz range. In the following application schematic example, the P2781A spread percentage selection is determined by the external LF value specified in the Loop Filter Selection Table. The *Input Frequency Selection Table* specifies the input frequency range. The external LF allows the user to fine tune the spread percentage to optimize the EMI reduction benefits of the spread spectrum.

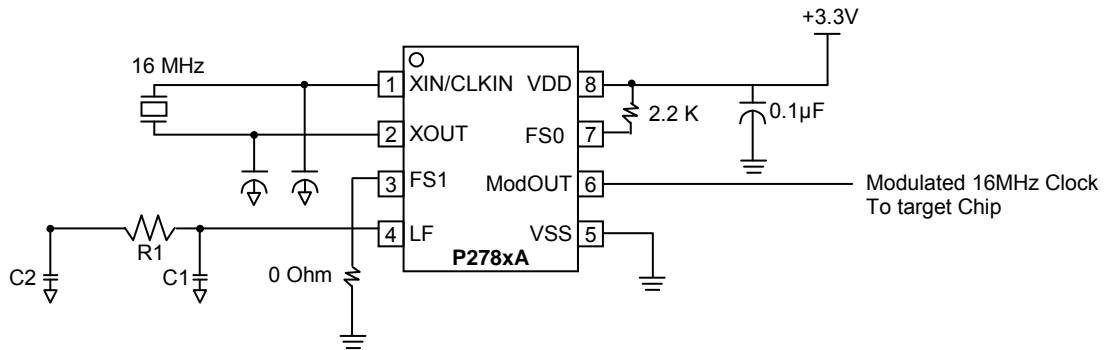

Note: Both logic input pins FS1 and FS0 have to be connected to either VDD or VSS. Do not leave them floating.

Absolute Maximum Ratings

Symbol	Parameter	Rating	Unit
V _{DD} , V _{IN}	Voltage on any pin with respect to Ground	-0.5 to +4.6	V
T _{STG}	Storage temperature	-65 to +125	°C
T _s	Max. Soldering Temperature (10 sec)	260	°C
T _J	Junction Temperature	150	°C
T _{DV}	Static Discharge Voltage (As per JEDEC STD22- A114-B)	2	KV

Note: These are stress ratings only and are not implied for functional use. Exposure to absolute maximum ratings for prolonged periods of time may affect device reliability.

Operating Conditions

Parameter	Description	Min	Max	Unit
V _{DD}	Supply Voltage	3.0	3.6	V
T _A	Operating Temperature (Ambient Temperature)	-40	+85	°C
C _L	Load Capacitance		15	pF
C _{IN}	Input Capacitance		7	pF

DC Electrical Characteristics

(Test condition: All parameters are measured at room temperature (+25°C) unless otherwise stated.)

Symbol	Parameter	Min	Typ	Max	Unit
V _{IL}	Input low voltage	VSS – 0.3		0.8	V
V _{IH}	Input high voltage	2.0		VDD +0.3	V
I _{IL}	Input low current (internal input pull-up resistor on FS0 and FS1)		60		µA
I _{IH}	Input high current (internal input pull-up resistor on FS0 and FS1)		60		µA
I _{XOL}	XOUT output low current		10		mA
I _{XOH}	XOUT output high current		10		mA
V _{OL}	Output low voltage (VDD = 3.3V, I _{OL} = 20mA)			0.4	V
V _{OH}	Output high voltage (VDD = 3.3V, I _{OH} = 20mA)	2.5			V
I _{DD}	Static supply current		3		mA
I _{CC}	Typical dynamic supply current (25pF scope probe loading)	5.2 at 3MHz		21.2 at 82MHz	mA
V _{DD}	Operating voltage	3.0	3.3	3.6	V

AC Electrical Characteristics

Symbol	Parameter		Min	Typ	Max	Unit	
f _{IN}	Input frequency: P278xA		3		78	MHz	
f _{OUT}	Output frequency:	P2781A	3		78		
		P2782A	6		156		
		P2784A	12		312		
t _{LH}	P278xA	Output rise time (measured at 0.8V to 2.0V, 25pF scope probe loading)		1		nS	
t _{HL}	P278xA	Output fall time (measured at 2.0V to 0.8V, 25 pF scope probe loading)		1		nS	
t _{JC}	P2781A	Jitter (cycle-to-cycle, ±6sigma, 1000 sweeps, ±0.5% spread, I/O frequency = 16MHz)		±250		pS	
t _D	P2781A	Output duty cycle deviation (error from 50% duty cycle, 25pF scope probe loading)		±1 @ 3MHz		±2 @ 82MHz	%
ΔF	P278xA	Frequency deviation tolerance from BW% stated in the <i>Loop Filter Selection Table</i>		-20	0	+20	%

Package Information

8-Pin SOIC Package

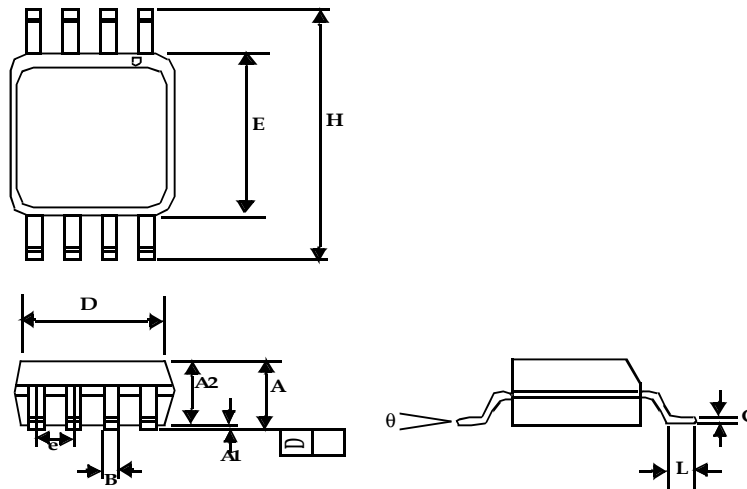

Symbol	Dimensions			
	Inches		Millimeters	
	Min	Max	Min	Max
A1	0.004	0.010	0.10	0.25
A	0.053	0.069	1.35	1.75
A2	0.049	0.059	1.25	1.50
B	0.012	0.020	0.31	0.51
C	0.007	0.010	0.18	0.25
D	0.193 BSC		4.90 BSC	
E	0.154 BSC		3.91 BSC	
e	0.050 BSC		1.27 BSC	
H	0.236 BSC		6.00 BSC	
L	0.016	0.050	0.41	1.27
θ	0°	8°	0°	8°

Note: Controlling dimensions are millimeters.
SOIC - 0.074 grams unit weight.

Ordering Codes

Ordering #	Top Marking	Package Type	Temperature
P2781AF-08ST	ABG	8 PIN SOIC, TUBE, Pb Free	0°C to +70°C
P2781AF-08SR	ABG	8 PIN SOIC, TAPE AND REEL, Pb Free	0°C to +70°C
I2781AF-08ST	ABH	8 PIN SOIC, TUBE, Pb Free	-40°C to +85°C
I2781AG-08SR	ABJ	8 PIN SOIC, TAPE AND REEL, Green	-40°C to +85°C
P2782AF-08SR	ABK	8 PIN SOIC, TAPE AND REEL, Pb Free	0°C to +70°C
P2784AF-08SR	ABO	8 PIN SOIC, TAPE AND REEL, Pb Free	0°C to +70°C

A "microdot" placed at the end of last row of marking or just below the last row toward the center of package indicates Pb-free.

ON Semiconductor and  are registered trademarks of Semiconductor Components Industries, LLC (SCILLC). SCILLC reserves the right to make changes without further notice to any products herein. SCILLC makes no warranty, representation or guarantee regarding the suitability of its products for any particular purpose, nor does SCILLC assume any liability arising out of the application or use of any product or circuit, and specifically disclaims any and all liability, including without limitation special, consequential or incidental damages. "Typical" parameters which may be provided in SCILLC data sheets and/or specifications can and do vary in different applications and actual performance may vary over time. All operating parameters, including "Typicals" must be validated for each customer application by customer's technical experts. SCILLC does not convey any license under its patent rights nor the rights of others. SCILLC products are not designed, intended, or authorized for use as components in systems intended for surgical implant into the body, or other applications intended to support or sustain life, or for any other application in which the failure of the SCILLC product could create a situation where personal injury or death may occur. Should Buyer purchase or use SCILLC products for any such unintended or unauthorized application, Buyer shall indemnify and hold SCILLC and its officers, employees, subsidiaries, affiliates, and distributors harmless against all claims, costs, damages, and expenses, and reasonable attorney fees arising out of, directly or indirectly, any claim of personal injury or death associated with such unintended or unauthorized use, even if such claim alleges that SCILLC was negligent regarding the design or manufacture of the part. SCILLC is an Equal Opportunity/Affirmative Action Employer. U.S Patent Pending; Timing-Safe and Active Bead are trademarks of PulseCore Semiconductor, a wholly owned subsidiary of ON Semiconductor. This literature is subject to all applicable copyright laws and is not for resale in any manner.

PUBLICATION ORDERING INFORMATION

LITERATURE FULFILLMENT:

Literature Distribution Center for ON Semiconductor
P.O. Box 5163, Denver, Colorado 80217 USA
Phone: 303-675-2175 or 800-344-3860 Toll Free USA/Canada
Fax: 303-675-2176 or 800-344-3867 Toll Free USA/Canada
Email: orderlit@onsemi.com

N. American Technical Support: 800-282-9855
Toll Free USA/Canada
Europe, Middle East and Africa Technical Support:
Phone: 421 33 790 2910
Japan Customer Focus Center
Phone: 81-3-5773-3850

ON Semiconductor Website:
www.onsemi.com

Order Literature: <http://www.onsemi.com/orderlit>

For additional information, please contact your local Sales Representative

Looking for pricing, stock, or lifecycle information?

Click below to explore more details on WIN SOURCE:

 [View P2782AF-08SR](#) on WIN SOURCE

 [ON Semiconductor](#) Information

Optimize Your Supply Chain with WIN SOURCE Solutions

-  Global Sourcing Solution
-  Obsolete Management
-  Cost Control Management
-  Shortage Management
-  Alternative Solution
-  Excess Inventory Management