



**THE DATASHEET OF
MOC8113M**



MOC8111M, MOC8112M, MOC8113M

6-Pin DIP Optocoupler for Power Supply Applications (No Base Connection)

Features

- High isolation voltage
7500 VAC Peak—1 second
- High BV_{CEO} minimum 70 Volts
- Current transfer ratio in selected groups:
MOC8111M: 20% min.
MOC8112M: 50% min.
MOC8113M: 100% min.
- Maximum switching time in saturation specified
- Underwriters Laboratory (UL) recognized
(File #E90700, Vol. 2)
- IEC60747-5-2 approved (ordering option V)

Applications

- Power supply regulators
- Digital logic inputs
- Microprocessor inputs
- Appliance sensor systems
- Industrial controls

Description

The MOC811XM series consists of a Gallium Arsenide IRED coupled with an NPN phototransistor. The base of the transistor is not bonded to an external pin for improved noise immunity.

Schematic

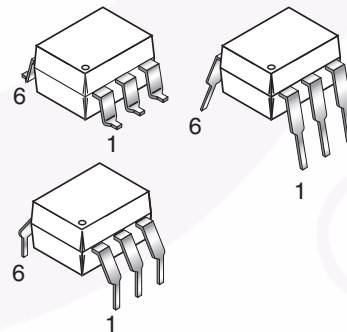
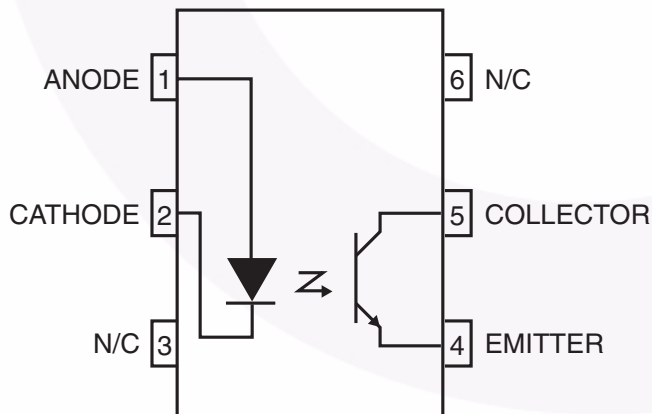

Absolute Maximum Ratings ($T_A = 25^\circ\text{C}$ Unless otherwise specified.)

Stresses exceeding the absolute maximum ratings may damage the device. The device may not function or be operable above the recommended operating conditions and stressing the parts to these levels is not recommended. In addition, extended exposure to stresses above the recommended operating conditions may affect device reliability. The absolute maximum ratings are stress ratings only.

Symbol	Parameter	Value	Unit
TOTAL DEVICE			
P_D	Total Device Power Dissipation @ $T_A = 25^\circ\text{C}$	260	mW
	Derate above 25°C	3.5	$\text{mW}/^\circ\text{C}$
T_{OPR}	Ambient Operating Temperature Range	-40 to +100	$^\circ\text{C}$
T_{STG}	Storage Temperature Range	-40 to +150	$^\circ\text{C}$
T_{SOL}	Lead Soldering Temperature (Wave Solder) (1/16" from case, 10 sec. duration)	260	$^\circ\text{C}$
INPUT LED			
I_F	Forward Current – Continuous	90	mA
$I_F(\text{pk})$	Forward Current – Peak (PW = $1\mu\text{s}$, 300pps)	3	A
V_R	Reverse Voltage	6	V
P_D	LED Power Dissipation @ $T_A = 25^\circ\text{C}$	135	mW
	Derate above 25°C	1.8	$\text{mW}/^\circ\text{C}$
OUTPUT TRANSISTOR			
P_D	Detector Power Dissipation @ $T_A = 25^\circ\text{C}$	200	mW
	Derate above 25°C	2.67	$\text{mW}/^\circ\text{C}$

Electrical Characteristics (T_A = 25°C Unless otherwise specified.)

Individual Component Characteristics

Symbol	Parameter	Test Conditions	Min.	Typ.	Max.	Unit
EMITTER						
V _F	Input Forward Voltage	I _F = 60mA		1.35	1.65	V
		I _F = 10mA		1.15	1.50	
V _R	Reverse Voltage	I _R = 10μA	6.0	15		V
C _J	Capacitance	V _F = 0V, f = 1.0MHz		50		pF
		V _F = 1V, f = 1.0MHz		65		
I _R	Reverse Leakage Current	V _R = 3.0V		.35	10	μA
DETECTOR						
BV _{CEO}	Breakdown Voltage, Collector to Emitter	I _C = 1.0mA, I _F = 0	70			V
BV _{ECO}	Breakdown Voltage, Emitter to Collector	I _E = 100μA, I _F = 0	7			V
I _{CEO}	Leakage Current, Collector to Emitter	V _{CE} = 10V, I _F = 0		5	50	V
C _{CE}	Capacitance, Collector to Emitter	V _{CE} = 0 V, f = 1MHz		8		pF

Isolation Characteristics

Symbol	Characteristic	Test Conditions	Min.	Typ.	Max.	Units
V _{ISO}	Input-Output Isolation Voltage	f = 60Hz, t = 1 sec.	7500			V _{AC(PK)}
C _{ISO}	Isolation Capacitance	V _{I-O} = 0, f = 1MHz		0.5		pF

Transfer Characteristic

Symbol	Characteristics	Test Conditions	Device	Min.	Typ.	Max.	Units
DC CHARACTERISTICS							
CTR	Output/Input Current Transfer Ratio	I _F = 10mA, V _{CE} = 5V	MOC8111M	20			%
			MOC8112M	50			
			MOC8113M	100			
V _{CE(SAT)}	Collector-Emitter Saturation Voltage	I _F = 10mA, I _C = 2.5mA	All		0.27	0.4	V
AC CHARACTERISTICS							
Non-Saturated Switching Times							
t _{on}	Turn-On Time	R _L = 100Ω, I _C = 2mA, V _{CC} = 10V, See Figure 7	All		6.0	10	μs
t _{off}	Turn-Off Time		All		5.5	10	μs
Saturated Switching Times							
t _{on}	Turn-On Time	I _F = 20mA, V _{CE} = 0.4V	MOC8111M		3.0	5.5	μs
		I _F = 10mA, V _{CE} = 0.4V	MOC812M/3M		4.2	8.0	
t _r	Rise-Time	I _F = 20mA, V _{CE} = 0.4V	MOC8111M		2.0	4.0	μs
		I _F = 10mA, V _{CE} = 0.4V	MOC812M/3M		3.0	6.0	
t _{off}	Turn-Off Time	I _F = 20mA, V _{CE} = 0.4V	MOC8111M		18	34	μs
		I _F = 10mA, V _{CE} = 0.4V	MOC812M/3M		23	39	
t _f	Fall-Time	I _F = 20mA, V _{CE} = 0.4V	MOC8111M		11	20	μs
		I _F = 10mA, V _{CE} = 0.4V	MOC812M/3M		14	24	

Safety and Insulation Ratings

As per IEC 60747-5-2, this optocoupler is suitable for “safe electrical insulation” only within the safety limit data. Compliance with the safety ratings shall be ensured by means of protective circuits.

Symbol	Parameter	Min.	Typ.	Max.	Unit
	Installation Classifications per DIN VDE 0110/1.89 Table 1				
	For Rated Main Voltage < 150Vrms		I-IV		
	For Rated Main voltage < 300Vrms		I-IV		
	Climatic Classification		55/100/21		
	Pollution Degree (DIN VDE 0110/1.89)		2		
CTI	Comparative Tracking Index	175			
V_{PR}	Input to Output Test Voltage, Method b, $V_{IORM} \times 1.875 = V_{PR}$, 100% Production Test with $t_m = 1$ sec, Partial Discharge < 5pC	1594			V_{peak}
	Input to Output Test Voltage, Method a, $V_{IORM} \times 1.5 = V_{PR}$, Type and Sample Test with $t_m = 60$ sec, Partial Discharge < 5pC	1275			V_{peak}
V_{IORM}	Max. Working Insulation Voltage	850			V_{peak}
V_{IOTM}	Highest Allowable Over Voltage	6000			V_{peak}
	External Creepage	7			mm
	External Clearance	7			mm
	Insulation Thickness	0.5			mm
RIO	Insulation Resistance at T_s , $V_{IO} = 500V$	10^9			Ω

Typical Performance Characteristics

Fig. 1 LED Forward Voltage vs. Forward Current

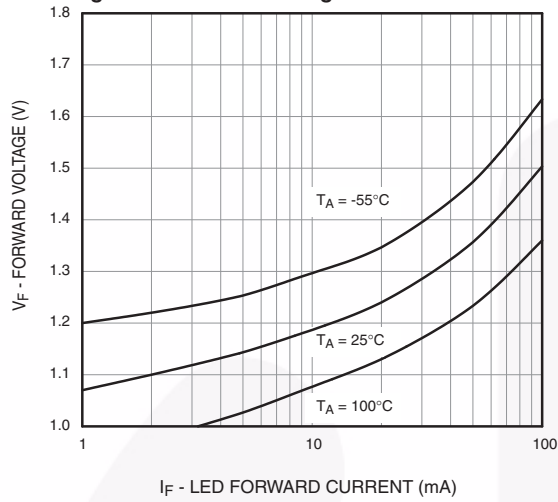

Fig. 2 Normalized CTR vs. Forward Current

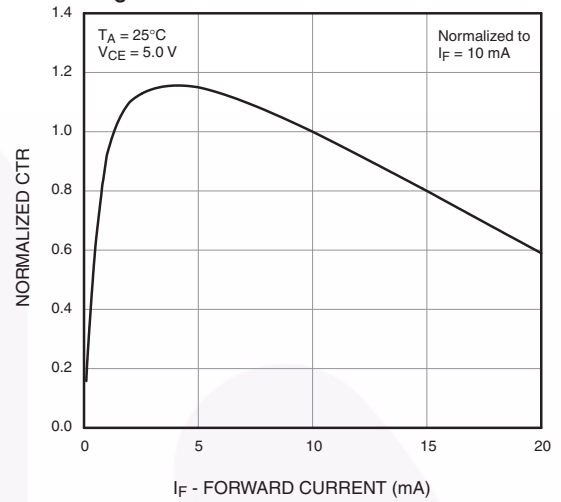

Fig. 3 Normalized CTR vs. Ambient Temperature

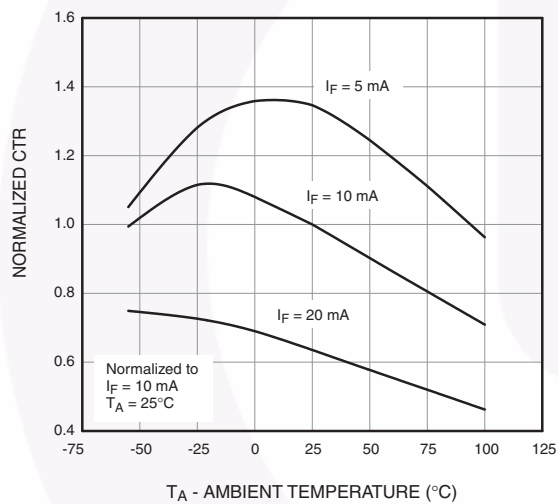

Fig. 4 Collector Emitter Saturation Voltage vs. Collector Current

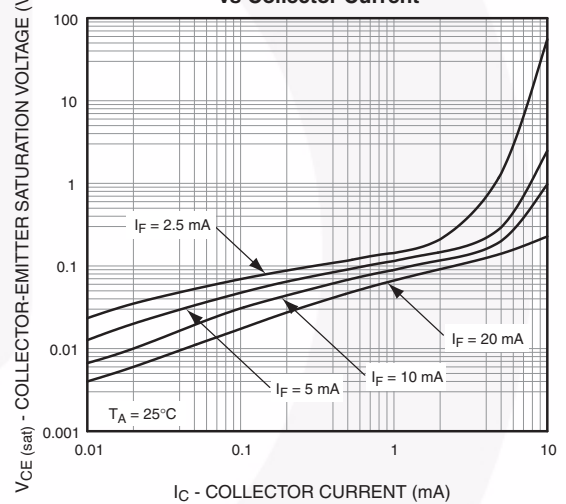

Fig. 5 Switching Speed vs. Load Resistor

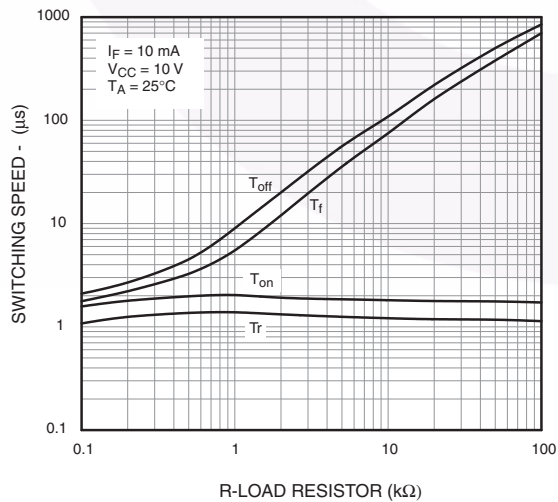
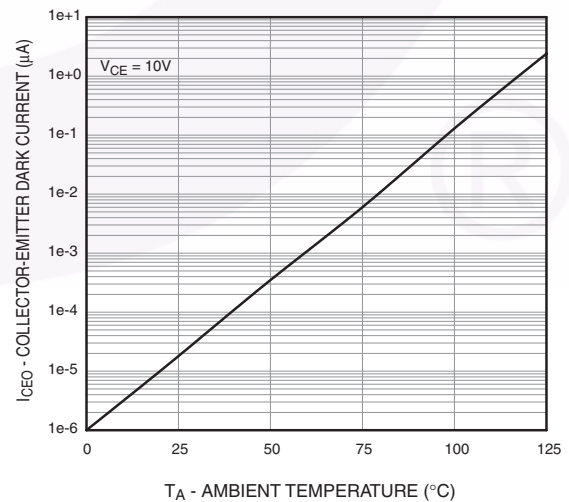

Fig. 6 Dark current vs. Ambient Temperature.



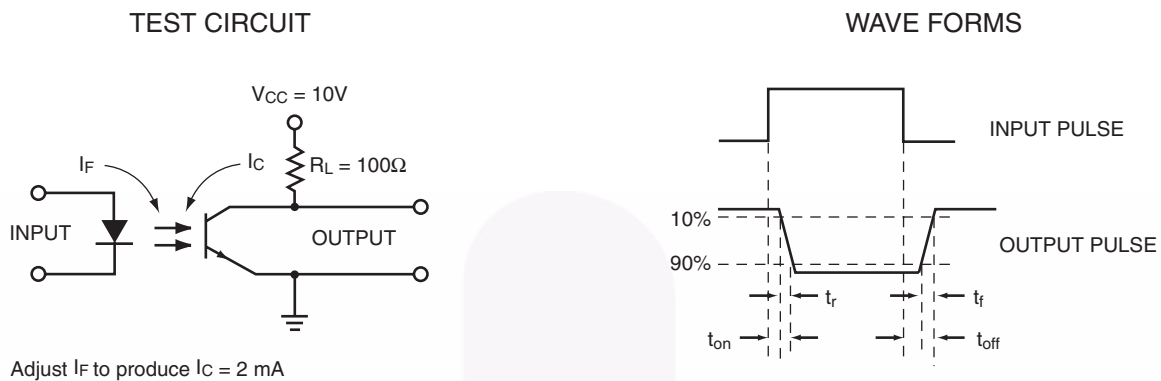
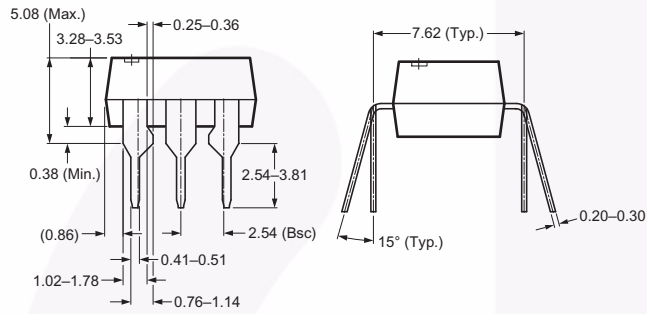
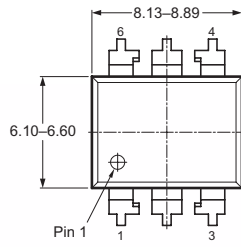

Figure 7. Switching Time Test Circuit and Waveforms

Package Dimensions

Through Hole



0.4" Lead Spacing

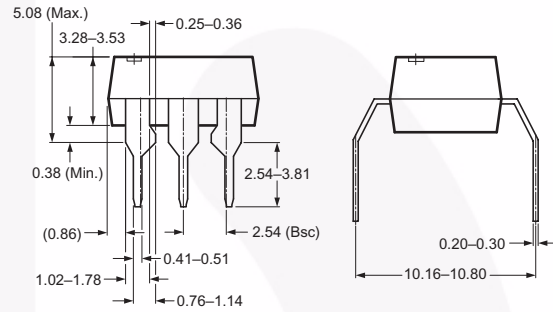
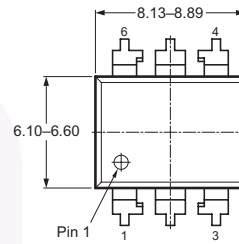

Surface Mount

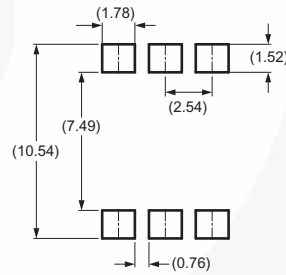
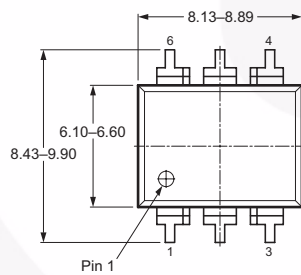

Recommended Pad Layout

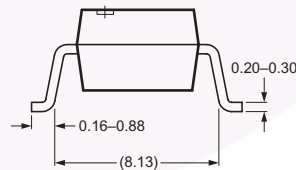
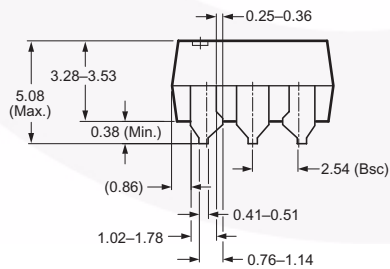

Note:
All dimensions in mm.

Ordering Information

Option	Example Part Number	Description
No Suffix	MOC8111M	Through Hole
S	MOC8111SM	Surface Mount Lead Bend
SR2	MOC8111SR2M	Surface Mount; Tape and Reel
T	MOC8111TM	0.4" Lead Spacing
V	MOC8111VM	VDE 0884
TV	MOC8111TVM	IEC60747-5-2 (VDE), 0.4" Lead Spacing
SV	MOC8111SVM	IEC60747-5-2 (VDE), Surface Mount
SR2V	MOC8111SR2VM	IEC60747-5-2 (VDE), Surface Mount, Tape and Reel

Marking Information

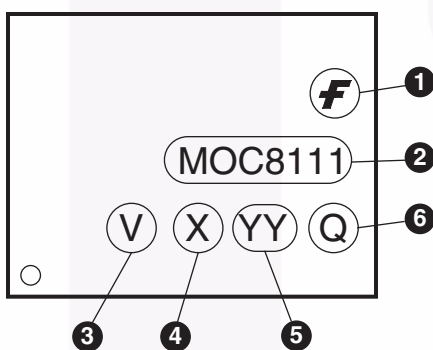

Definitions	
1	Fairchild logo
2	Device number
3	VDE mark (Note: Only appears on parts ordered with VDE option – See order entry table)
4	One digit year code, e.g., '8'
5	Two digit work week ranging from '01' to '53'
6	Assembly package code

Tape Dimensions

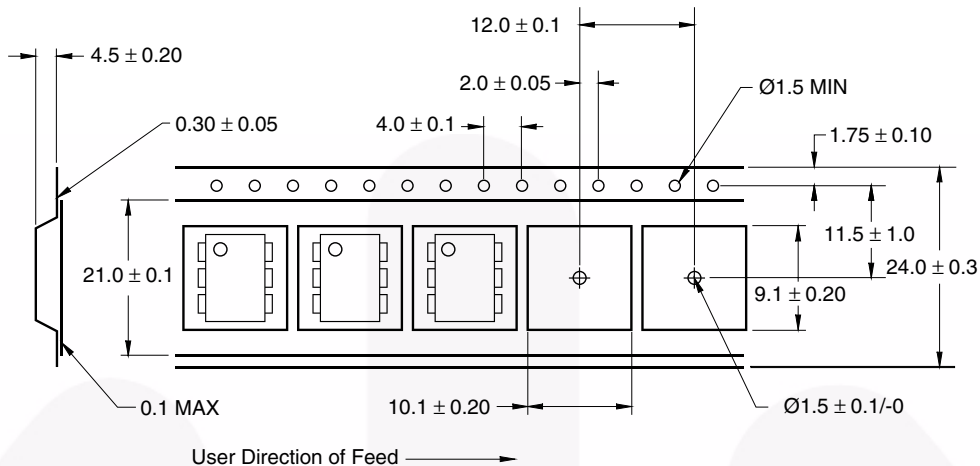

Note:
All dimensions are in millimeters.



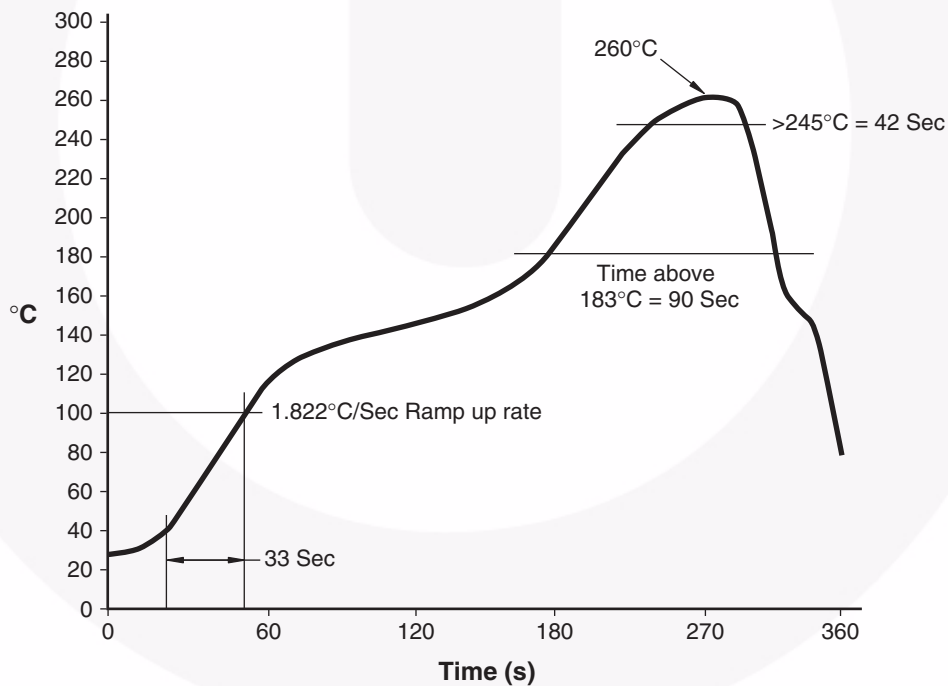

Reflow Profile





TRADEMARKS

The following includes registered and unregistered trademarks and service marks, owned by Fairchild Semiconductor and/or its global subsidiaries, and is not intended to be an exhaustive list of all such trademarks.

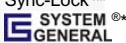
- | | | | |
|--|---|--|---|
| Auto-SPM™ | F-PFS™ | PowerTrench® | The Power Franchise® |
| Build it Now™ | FRFET® | PowerXS™ | the power franchise |
| CorePLUS™ | Global Power Resource™ | Programmable Active Droop™ | TinyBoost™ |
| CorePOWER™ | Green FPS™ | QFET® | TinyBuck™ |
| CROSSVOLT™ | Green FPS™ e-Series™ | QS™ | TinyLogic® |
| CTL™ | Gmax™ | Quiet Series™ | TINYOPTO™ |
| Current Transfer Logic™ | GTO™ | RapidConfigure™ | TinyPower™ |
| EcoSPARK® | IntelliMAX™ |  ™ | TinyPWM™ |
| EfficientMax™ | ISOPLANAR™ | Saving our world, 1mW/W/kW at a time™ | TinyWire™ |
| EZSWITCH™* | MegaBuck™ | SmartMax™ | TriFault Detect™ |
|  ™* | MICROCOUPLER™ | SMART START™ | TRUECURRENT™* |
|  ® | MicroFET™ | SPM® | μSerDes™ |
| Fairchild® | MicroPak™ | STEALTH™ |  SerDes® |
| Fairchild Semiconductor® | MillerDrive™ | SuperFET™ | UHC® |
| FACT Quiet Series™ | MotionMax™ | SuperSOT™-3 | Ultra FRFET™ |
| FACT® | Motion-SPM™ | SuperSOT™-6 | UniFET™ |
| FAST® | OPTOLOGIC® | SuperSOT™-8 | VCX™ |
| FastvCore™ | OPTOPLANAR® | SupreMOS™ | VisualMax™ |
| FETBench™ |  ™ | SyncFET™ | XS™ |
| FlashWriter®* | PDP SPM™ | Sync-Lock™ | |
| FPS™ | Power-SPM™ |  SYSTEM GENERAL®* | |

* Trademarks of System General Corporation, used under license by Fairchild Semiconductor.

DISCLAIMER

FAIRCHILD SEMICONDUCTOR RESERVES THE RIGHT TO MAKE CHANGES WITHOUT FURTHER NOTICE TO ANY PRODUCTS HEREIN TO IMPROVE RELIABILITY, FUNCTION, OR DESIGN. FAIRCHILD DOES NOT ASSUME ANY LIABILITY ARISING OUT OF THE APPLICATION OR USE OF ANY PRODUCT OR CIRCUIT DESCRIBED HEREIN; NEITHER DOES IT CONVEY ANY LICENSE UNDER ITS PATENT RIGHTS, NOR THE RIGHTS OF OTHERS. THESE SPECIFICATIONS DO NOT EXPAND THE TERMS OF FAIRCHILD'S WORLDWIDE TERMS AND CONDITIONS, SPECIFICALLY THE WARRANTY THEREIN, WHICH COVERS THESE PRODUCTS.

LIFE SUPPORT POLICY

FAIRCHILD'S PRODUCTS ARE NOT AUTHORIZED FOR USE AS CRITICAL COMPONENTS IN LIFE SUPPORT DEVICES OR SYSTEMS WITHOUT THE EXPRESS WRITTEN APPROVAL OF FAIRCHILD SEMICONDUCTOR CORPORATION.

As used herein:

- Life support devices or systems are devices or systems which, (a) are intended for surgical implant into the body or (b) support or sustain life, and (c) whose failure to perform when properly used in accordance with instructions for use provided in the labeling, can be reasonably expected to result in a significant injury of the user.
- A critical component in any component of a life support, device, or system whose failure to perform can be reasonably expected to cause the failure of the life support device or system, or to affect its safety or effectiveness.

ANTI-COUNTERFEITING POLICY

Fairchild Semiconductor Corporation's Anti-Counterfeiting Policy. Fairchild's Anti-Counterfeiting Policy is also stated on our external website, www.fairchildsemi.com, under Sales Support.

Counterfeiting of semiconductor parts is a growing problem in the industry. All manufacturers of semiconductor products are experiencing counterfeiting of their parts. Customers who inadvertently purchase counterfeit parts experience many problems such as loss of brand reputation, substandard performance, failed applications, and increased cost of production and manufacturing delays. Fairchild is taking strong measures to protect ourselves and our customers from the proliferation of counterfeit parts. Fairchild strongly encourages customers to purchase Fairchild parts either directly from Fairchild or from Authorized Fairchild Distributors who are listed by country on our web page cited above. Products customers buy either from Fairchild directly or from Authorized Fairchild Distributors are genuine parts, have full traceability, meet Fairchild's quality standards for handling and storage and provide access to Fairchild's full range of up-to-date technical and product information. Fairchild and our Authorized Distributors will stand behind all warranties and will appropriately address any warranty issues that may arise. Fairchild will not provide any warranty coverage or other assistance for parts bought from Unauthorized Sources. Fairchild is committed to combat this global problem and encourage our customers to do their part in stopping this practice by buying direct or from authorized distributors.

PRODUCT STATUS DEFINITIONS

Definition of Terms

Datasheet Identification	Product Status	Definition
Advance Information	Formative / In Design	Datasheet contains the design specifications for product development. Specifications may change in any manner without notice.
Preliminary	First Production	Datasheet contains preliminary data; supplementary data will be published at a later date. Fairchild Semiconductor reserves the right to make changes at any time without notice to improve design.
No Identification Needed	Full Production	Datasheet contains final specifications. Fairchild Semiconductor reserves the right to make changes at any time without notice to improve the design.
Obsolete	Not In Production	Datasheet contains specifications on a product that is discontinued by Fairchild Semiconductor. The datasheet is for reference information only.

Rev. I40

Looking for pricing, stock, or lifecycle information?

Click below to explore more details on WIN SOURCE:

- ⊖ [View MOC8113M on WIN SOURCE](#)
- ⊖ [Fairchild/ON Semiconductor Information](#)

Optimize Your Supply Chain with WIN SOURCE Solutions

- ✓ Global Sourcing Solution
- ✓ Obsolete Management
- ✓ Cost Control Management
- ✓ Shortage Management
- ✓ Alternative Solution
- ✓ Excess Inventory Management