



**THE DATASHEET OF
SN74LVCH16543ADGVR**



FEATURES

- Member of the Texas Instruments Widebus™ Family
- Operates From 1.65 V to 3.6 V
- Inputs Accept Voltages to 5.5 V
- Max t_{pd} of 5.4 ns at 3.3 V
- Typical V_{OLP} (Output Ground Bounce) < 0.8 V at $V_{CC} = 3.3$ V, $T_A = 25^\circ\text{C}$
- Typical V_{OHV} (Output V_{OH} Undershoot) > 2 V at $V_{CC} = 3.3$ V, $T_A = 25^\circ\text{C}$
- I_{off} Supports Partial-Power-Down Mode Operation
- Supports Mixed-Mode Signal Operation on All Ports (5-V Input/Output Voltage With 3.3-V V_{CC})
- Bus Hold on Data Inputs Eliminates the Need for External Pullup/Pulldown Resistors
- Latch-Up Performance Exceeds 250 mA Per JESD 17
- ESD Protection Exceeds JESD 22
 - 2000-V Human-Body Model (A114-A)
 - 200-V Machine Model (A115-A)
 - 1000-V Charged-Device Model (C101)

DESCRIPTION/ORDERING INFORMATION

This 16-bit registered transceiver is designed for 1.65-V to 3.6-V V_{CC} operation.

The SN74LVCH16543A can be used as two 8-bit transceivers or one 16-bit transceiver. Separate latch-enable (\overline{LEAB} or \overline{LEBA}) and output-enable (\overline{OEAB} or \overline{OEBA}) inputs are provided for each register, to permit independent control in either direction of data flow.

DGG, DGV, OR DL PACKAGE
(TOP VIEW)

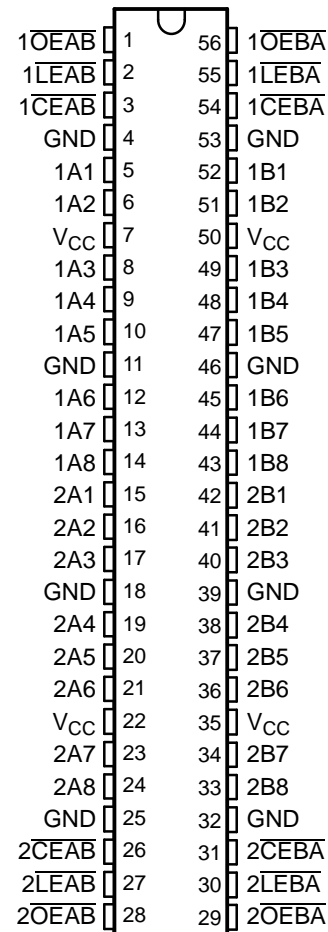

ORDERING INFORMATION

T_A	PACKAGE ⁽¹⁾		ORDERABLE PART NUMBER	TOP-SIDE MARKING
–40°C to 85°C	SSOP – DL	Tube	SN74LVCH16543ADL	LVCH16543A
		Tape and reel	SN74LVCH16543ADLR	
	TSSOP – DGG	Tape and reel	SN74LVCH16543ADGGR	LVCH16543A
	TVSOP – DGV	Tape and reel	SN74LVCH16543ADGVR	LDH543A
	VFBGA – GQL	Tape and reel	SN74LVCH16543AGQLR	LDH543A
VFBGA – ZQL (Pb-free)	SN74LVCH16543AZQLR			

(1) Package drawings, standard packing quantities, thermal data, symbolization, and PCB design guidelines are available at www.ti.com/sc/package.



Please be aware that an important notice concerning availability, standard warranty, and use in critical applications of Texas Instruments semiconductor products and disclaimers thereto appears at the end of this data sheet.

Widebus is a trademark of Texas Instruments.

SN74LVCH16543A
16-BIT REGISTERED TRANSCEIVER
WITH 3-STATE OUTPUTS

SCAS317M–NOVEMBER 1993–REVISED MARCH 2005

DESCRIPTION/ORDERING INFORMATION (CONTINUED)

The A-to-B enable (\overline{CEAB}) input must be low to enter data from A or to output data from B. If \overline{CEAB} is low and \overline{LEAB} is low, the A-to-B latches are transparent; a subsequent low-to-high transition of \overline{LEAB} puts the A latches in the storage mode. With \overline{CEAB} and \overline{OEAB} both low, the 3-state B outputs are active and reflect the data present at the output of the A latches. Data flow from B to A is similar, but requires using the \overline{CEBA} , \overline{LEBA} , and \overline{OEBA} inputs.

To ensure the high-impedance state during power up or power down, \overline{OE} should be tied to V_{CC} through a pullup resistor; the minimum value of the resistor is determined by the current-sinking capability of the driver.

Inputs can be driven from either 3.3-V or 5-V devices. This feature allows the use of this device as a translator in a mixed 3.3-V/5-V system environment.

This device is fully specified for partial-power-down applications using I_{off} . The I_{off} circuitry disables the outputs, preventing damaging current backflow through the device when it is powered down.

Active bus-hold circuitry is provided to hold unused or floating data inputs at a valid logic level. Use of pullup or pulldown resistors with the bus-hold circuitry is not recommended. The bus-hold circuitry is part of the input circuit and is not disabled by \overline{OE} or DIR.

GQL OR ZQL PACKAGE
(TOP VIEW)

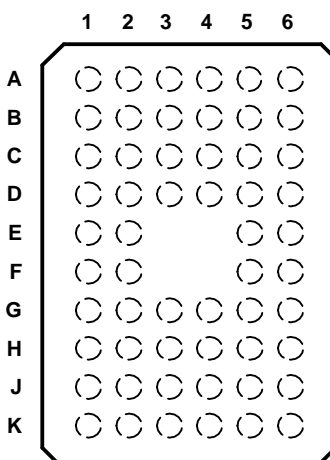

TERMINAL ASSIGNMENTS

	1	2	3	4	5	6
A	1 \overline{CEAB}	1 \overline{LEAB}	1 \overline{OEAB}	1 \overline{OEBA}	1 \overline{LEBA}	1 \overline{CEBA}
B	1A2	1A1	GND	GND	1B1	1B2
C	1A4	1A3	V_{CC}	V_{CC}	1B3	1B4
D	1A6	1A5	GND	GND	1B5	1B6
E	1A8	1A7			1B7	1B8
F	2A1	2A2			2B2	2B1
G	2A3	2A4	GND	GND	2B4	2B3
H	2A5	2A6	V_{CC}	V_{CC}	2B6	2B5
J	2A7	2A8	GND	GND	2B8	2B7
K	2 \overline{CEAB}	2 \overline{LEAB}	2 \overline{OEAB}	2 \overline{OEBA}	2 \overline{LEBA}	2 \overline{CEBA}

FUNCTION TABLE⁽¹⁾
(EACH 8-BIT SECTION)

INPUTS				OUTPUT B
\overline{CEAB}	\overline{LEAB}	\overline{OEAB}	A	
H	X	X	X	Z
X	X	H	X	Z
L	H	L	X	$B_0^{(2)}$
L	L	L	L	L
L	L	L	H	H

- (1) A-to-B data flow is shown; B-to-A flow control is the same, except that it uses \overline{CEBA} , \overline{LEBA} , and \overline{OEBA} .
- (2) Output level before the indicated steady-state input conditions were established

SN74LVCH16543A
16-BIT REGISTERED TRANSCEIVER
WITH 3-STATE OUTPUTS

SCAS317M—NOVEMBER 1993—REVISED MARCH 2005

LOGIC DIAGRAM (POSITIVE LOGIC)

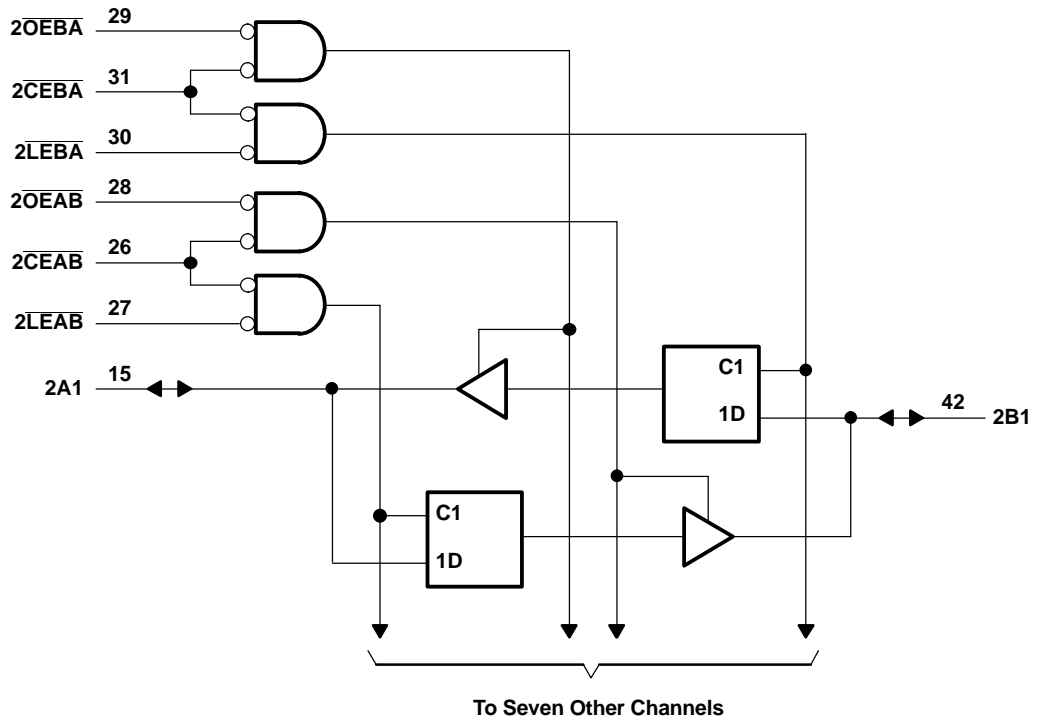
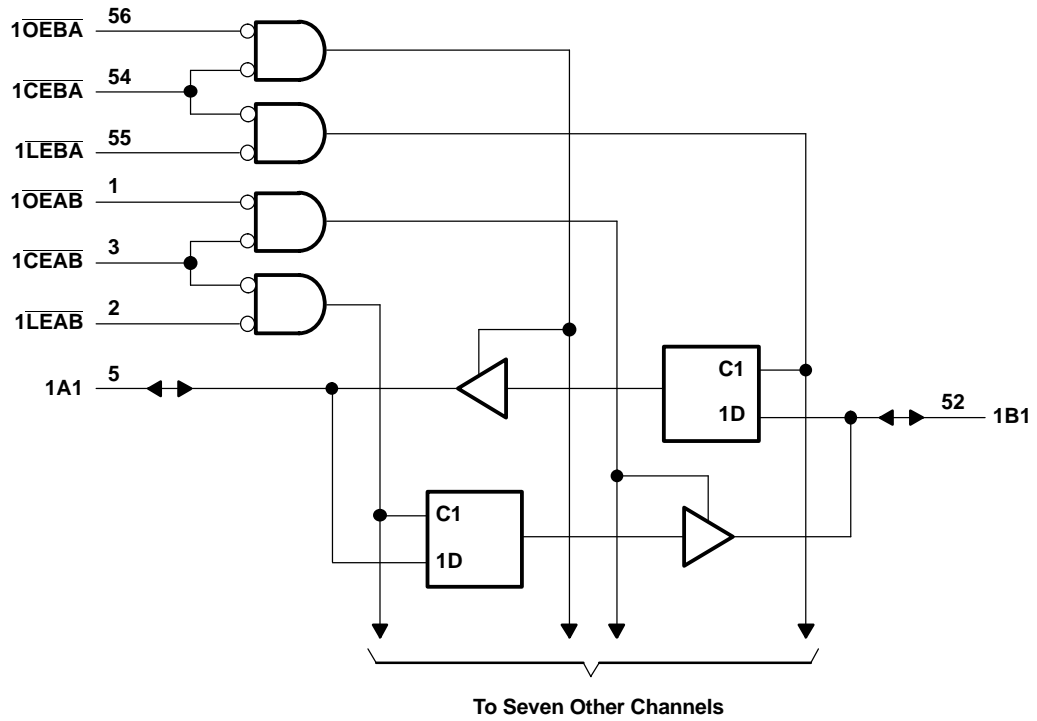

Pin numbers shown are for the DGG, DGV, and DL packages.

Absolute Maximum Ratings⁽¹⁾

over operating free-air temperature range (unless otherwise noted)

		MIN	MAX	UNIT
V_{CC}	Supply voltage range	−0.5	6.5	V
V_I	Input voltage range ⁽²⁾	−0.5	6.5	V
V_O	Voltage range applied to any output in the high-impedance or power-off state ⁽²⁾	−0.5	6.5	V
V_O	Voltage range applied to any output in the high or low state ⁽²⁾⁽³⁾	−0.5	$V_{CC} + 0.5$	V
I_{IK}	Input clamp current	$V_I < 0$	−50	mA
I_{OK}	Output clamp current	$V_O < 0$	−50	mA
I_O	Continuous output current		±50	mA
	Continuous current through each V_{CC} or GND		±100	mA
θ_{JA}	Package thermal impedance ⁽⁴⁾	DGG package	64	°C/W
		DGV package	48	
		DL package	56	
		GQL/ZQL package	42	
T_{stg}	Storage temperature range	−65	150	°C

- (1) Stresses beyond those listed under "absolute maximum ratings" may cause permanent damage to the device. These are stress ratings only, and functional operation of the device at these or any other conditions beyond those indicated under "recommended operating conditions" is not implied. Exposure to absolute-maximum-rated conditions for extended periods may affect device reliability.
- (2) The input negative-voltage and output voltage ratings may be exceeded if the input and output current ratings are observed.
- (3) The value of V_{CC} is provided in the recommended operating conditions table.
- (4) The package thermal impedance is calculated in accordance with JESD 51-7.

Recommended Operating Conditions⁽¹⁾

		MIN	MAX	UNIT	
V_{CC}	Supply voltage	Operating	1.65	3.6	V
		Data retention only	1.5		
V_{IH}	High-level input voltage	$V_{CC} = 1.65\text{ V to }1.95\text{ V}$	$0.65 \times V_{CC}$		V
		$V_{CC} = 2.3\text{ V to }2.7\text{ V}$	1.7		
		$V_{CC} = 2.7\text{ V to }3.6\text{ V}$	2		
V_{IL}	Low-level input voltage	$V_{CC} = 1.65\text{ V to }1.95\text{ V}$		$0.35 \times V_{CC}$	V
		$V_{CC} = 2.3\text{ V to }2.7\text{ V}$		0.7	
		$V_{CC} = 2.7\text{ V to }3.6\text{ V}$		0.8	
V_I	Input voltage	0	5.5	V	
V_O	Output voltage	High or low state	0	V_{CC}	V
		3-state	0	5.5	
I_{OH}	High-level output current	$V_{CC} = 1.65\text{ V}$		−4	mA
		$V_{CC} = 2.3\text{ V}$		−8	
		$V_{CC} = 2.7\text{ V}$		−12	
		$V_{CC} = 3\text{ V}$		−24	
I_{OL}	Low-level output current	$V_{CC} = 1.65\text{ V}$		4	mA
		$V_{CC} = 2.3\text{ V}$		8	
		$V_{CC} = 2.7\text{ V}$		12	
		$V_{CC} = 3\text{ V}$		24	
$\Delta t/\Delta v$	Input transition rise or fall rate		10	ns/V	
T_A	Operating free-air temperature	−40	85	°C	

- (1) All unused control inputs of the device must be held at V_{CC} or GND to ensure proper device operation. Refer to the TI application report, *Implications of Slow or Floating CMOS Inputs*, literature number SCBA004.

SN74LVCH16543A
16-BIT REGISTERED TRANSCEIVER
WITH 3-STATE OUTPUTS

SCAS317M–NOVEMBER 1993–REVISED MARCH 2005

Electrical Characteristics

over recommended operating free-air temperature range (unless otherwise noted)

PARAMETER		TEST CONDITIONS	V _{CC}	MIN	TYP ⁽¹⁾	MAX	UNIT
V _{OH}		I _{OH} = -100 μA	1.65 V to 3.6 V	V _{CC} - 0.2			V
		I _{OH} = -4 mA	1.65 V	1.2			
		I _{OH} = -8 mA	2.3 V	1.7			
		I _{OH} = -12 mA	2.7 V	2.2			
			3 V	2.4			
	I _{OH} = -24 mA	3 V	2.2				
V _{OL}		I _{OL} = 100 μA	1.65 V to 3.6 V			0.2	V
		I _{OL} = 4 mA	1.65 V			0.45	
		I _{OL} = 8 mA	2.3 V			0.7	
		I _{OL} = 12 mA	2.7 V			0.4	
		I _{OL} = 24 mA	3 V			0.55	
I _I	Control inputs	V _I = 0 to 5.5 V	3.6 V			±5	μA
I _{off}		V _I or V _O = 5.5 V	0			±10	μA
I _{I(hold)}	A or B ports	V _I = 0.58 V	1.65 V	(2)			μA
		V _I = 1.07 V		(2)			
		V _I = 0.7 V	2.3 V	45			
		V _I = 1.7 V		-45			
		V _I = 0.8 V	3 V	75			
		V _I = 2 V		-75			
		V _I = 0 to 3.6 V ⁽³⁾	3.6 V			±500	
I _{OZ} ⁽⁴⁾		V _O = 0 V or (V _{CC} to 5.5 V)	2.3 V to 3.6 V			±5	μA
I _{CC}		V _I = V _{CC} or GND, I _O = 0	3.6 V			20	μA
		3.6 V ≤ V _I ≤ 5.5 V ⁽⁵⁾ , I _O = 0				20	
ΔI _{CC}		One input at V _{CC} - 0.6 V, Other inputs at V _{CC} or GND	2.7 V to 3.6 V			500	μA
C _i	Control inputs	V _I = V _{CC} or GND	3.3 V			5	pF
C _{io}	A or B ports	V _O = V _{CC} or GND	3.3 V			8	pF

- (1) All typical values are at V_{CC} = 3.3 V, T_A = 25°C.
- (2) This information was not available at the time of publication.
- (3) This is the bus-hold maximum dynamic current required to switch the input from one state to another.
- (4) For the total leakage current in an I/O port, consult the I_{I(hold)} specification for the input voltage condition, 0 V < V_I < V_{CC}, and the I_{OZ} specification for the input voltage conditions, V_I = 0 V or V_I = V_{CC} to 5.5 V. The bus-hold current, at input voltage greater than V_{CC}, is negligible.
- (5) This applies in the disabled state only.

Timing Requirements

over recommended operating free-air temperature range (unless otherwise noted) (see Figure 1)

		V _{CC} = 1.8 V ± 0.15 V		V _{CC} = 2.5 V ± 0.2 V		V _{CC} = 2.7 V		V _{CC} = 3.3 V ± 0.3 V		UNIT
		MIN	MAX	MIN	MAX	MIN	MAX	MIN	MAX	
t _w	Pulse duration, \overline{LE} or \overline{CE} low	(1)		(1)		3.3		3.3		ns
t _{su}	Setup time, data before \overline{LE} or \overline{CE} ↓	(1)		(1)		1.1		1.1		ns
t _h	Hold time, data after \overline{LE} or \overline{CE} ↓	(1)		(1)		1.9		1.9		ns

- (1) This information was not available at the time of publication.

Switching Characteristics

over recommended operating free-air temperature range (unless otherwise noted) (see Figure 1)

PARAMETER	FROM (INPUT)	TO (OUTPUT)	$V_{CC} = 1.8\text{ V} \pm 0.15\text{ V}$		$V_{CC} = 2.5\text{ V} \pm 0.2\text{ V}$		$V_{CC} = 2.7\text{ V}$		$V_{CC} = 3.3\text{ V} \pm 0.3\text{ V}$		UNIT
			MIN	MAX	MIN	MAX	MIN	MAX	MIN	MAX	
t_{pd}	A or B	B or A	(1)	(1)	(1)	(1)	6.1		1.2	5.4	ns
	\overline{LE}	A or B	(1)	(1)	(1)	(1)	7.4		1.5	6.1	
t_{en}	\overline{CE}	A or B	(1)	(1)	(1)	(1)	7.9		1.2	6.6	ns
t_{dis}			(1)	(1)	(1)	(1)	7.1		1.5	6.6	
t_{en}	\overline{OE}	A or B	(1)	(1)	(1)	(1)	7.6		1	6.3	ns
t_{dis}			(1)	(1)	(1)	(1)	6.9		1.5	6.3	

(1) This information was not available at the time of publication.

Operating Characteristics

 $T_A = 25^\circ\text{C}$

PARAMETER		TEST CONDITIONS	$V_{CC} = 1.8\text{ V}$	$V_{CC} = 2.5\text{ V}$	$V_{CC} = 3.3\text{ V}$	UNIT
			TYP	TYP	TYP	
C_{pd}	Power dissipation capacitance per transceiver	Outputs enabled	(1)	(1)	44	pF
		Outputs disabled	(1)	(1)	4	

(1) This information was not available at the time of publication.

PARAMETER MEASUREMENT INFORMATION

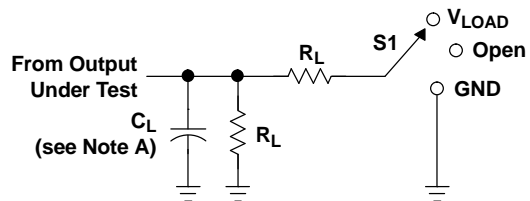

LOAD CIRCUIT

TEST	S1
t_{PLH}/t_{PHL}	Open
t_{PLZ}/t_{PZL}	V_{LOAD}
t_{PHZ}/t_{PZH}	GND

V_{CC}	INPUTS		V_M	V_{LOAD}	C_L	R_L	V_{Δ}
	V_I	t_r/t_f					
$1.8\text{ V} \pm 0.15\text{ V}$	V_{CC}	$\leq 2\text{ ns}$	$V_{CC}/2$	$2 \times V_{CC}$	30 pF	1 k Ω	0.15 V
$2.5\text{ V} \pm 0.2\text{ V}$	V_{CC}	$\leq 2\text{ ns}$	$V_{CC}/2$	$2 \times V_{CC}$	30 pF	500 Ω	0.15 V
2.7 V	2.7 V	$\leq 2.5\text{ ns}$	1.5 V	6 V	50 pF	500 Ω	0.3 V
$3.3\text{ V} \pm 0.3\text{ V}$	2.7 V	$\leq 2.5\text{ ns}$	1.5 V	6 V	50 pF	500 Ω	0.3 V

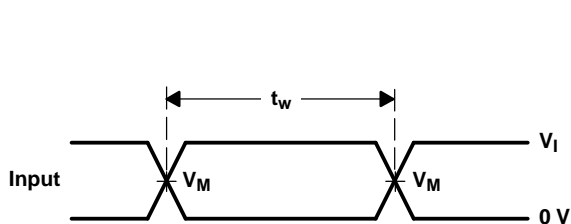

VOLTAGE WAVEFORMS
PULSE DURATION

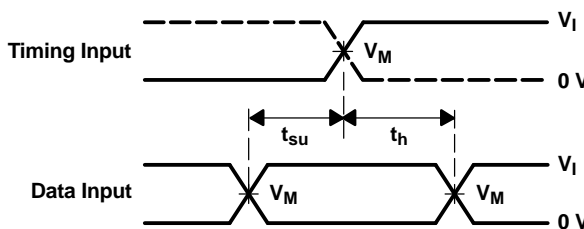

VOLTAGE WAVEFORMS
SETUP AND HOLD TIMES

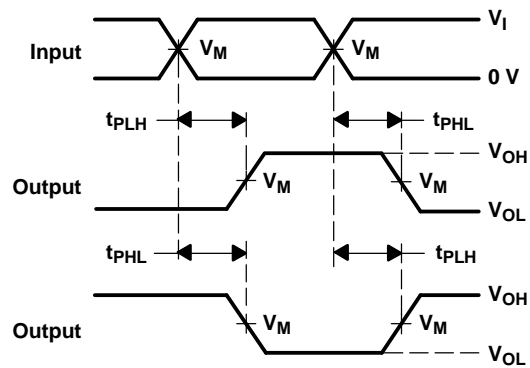

VOLTAGE WAVEFORMS
PROPAGATION DELAY TIMES
INVERTING AND NONINVERTING OUTPUTS

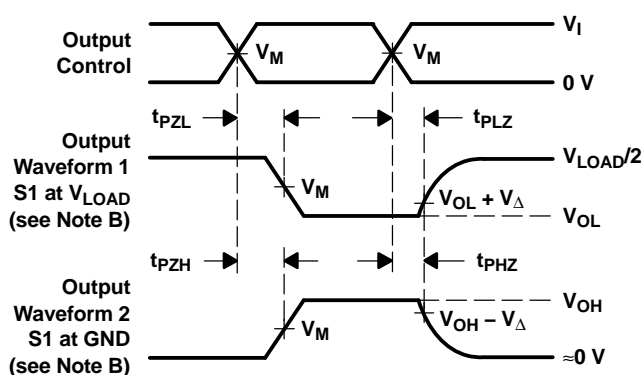

VOLTAGE WAVEFORMS
ENABLE AND DISABLE TIMES
LOW- AND HIGH-LEVEL ENABLING

- NOTES:
- A. C_L includes probe and jig capacitance.
 - B. Waveform 1 is for an output with internal conditions such that the output is low, except when disabled by the output control. Waveform 2 is for an output with internal conditions such that the output is high, except when disabled by the output control.
 - C. All input pulses are supplied by generators having the following characteristics: $PRR \leq 10\text{ MHz}$, $Z_O = 50\ \Omega$.
 - D. The outputs are measured one at a time, with one transition per measurement.
 - E. t_{PLZ} and t_{PHZ} are the same as t_{dis} .
 - F. t_{PZL} and t_{PZH} are the same as t_{en} .
 - G. t_{PLH} and t_{PHL} are the same as t_{pd} .
 - H. All parameters and waveforms are not applicable to all devices.

Figure 1. Load Circuit and Voltage Waveforms

PACKAGING INFORMATION

Orderable Device	Status (1)	Package Type	Package Drawing	Pins	Package Qty	Eco Plan (2)	Lead/Ball Finish (6)	MSL Peak Temp (3)	Op Temp (°C)	Device Marking (4/5)	Samples
SN74LVCH16543ADGGR	ACTIVE	TSSOP	DGG	56	2000	Green (RoHS & no Sb/Br)	CU NIPDAU	Level-1-260C-UNLIM	-40 to 85	LVCH16543A	Samples
SN74LVCH16543ADL	ACTIVE	SSOP	DL	56	20	Green (RoHS & no Sb/Br)	CU NIPDAU	Level-1-260C-UNLIM	-40 to 85	LVCH16543A	Samples
SN74LVCH16543ADLR	ACTIVE	SSOP	DL	56	1000	Green (RoHS & no Sb/Br)	CU NIPDAU	Level-1-260C-UNLIM	-40 to 85	LVCH16543A	Samples

(1) The marketing status values are defined as follows:

ACTIVE: Product device recommended for new designs.

LIFEBUY: TI has announced that the device will be discontinued, and a lifetime-buy period is in effect.

NRND: Not recommended for new designs. Device is in production to support existing customers, but TI does not recommend using this part in a new design.

PREVIEW: Device has been announced but is not in production. Samples may or may not be available.

OBSOLETE: TI has discontinued the production of the device.

(2) **RoHS:** TI defines "RoHS" to mean semiconductor products that are compliant with the current EU RoHS requirements for all 10 RoHS substances, including the requirement that RoHS substance do not exceed 0.1% by weight in homogeneous materials. Where designed to be soldered at high temperatures, "RoHS" products are suitable for use in specified lead-free processes. TI may reference these types of products as "Pb-Free".

RoHS Exempt: TI defines "RoHS Exempt" to mean products that contain lead but are compliant with EU RoHS pursuant to a specific EU RoHS exemption.

Green: TI defines "Green" to mean the content of Chlorine (Cl) and Bromine (Br) based flame retardants meet JS709B low halogen requirements of <=1000ppm threshold. Antimony trioxide based flame retardants must also meet the <=1000ppm threshold requirement.

(3) MSL, Peak Temp. - The Moisture Sensitivity Level rating according to the JEDEC industry standard classifications, and peak solder temperature.

(4) There may be additional marking, which relates to the logo, the lot trace code information, or the environmental category on the device.

(5) Multiple Device Markings will be inside parentheses. Only one Device Marking contained in parentheses and separated by a "~" will appear on a device. If a line is indented then it is a continuation of the previous line and the two combined represent the entire Device Marking for that device.

(6) Lead/Ball Finish - Orderable Devices may have multiple material finish options. Finish options are separated by a vertical ruled line. Lead/Ball Finish values may wrap to two lines if the finish value exceeds the maximum column width.

Important Information and Disclaimer: The information provided on this page represents TI's knowledge and belief as of the date that it is provided. TI bases its knowledge and belief on information provided by third parties, and makes no representation or warranty as to the accuracy of such information. Efforts are underway to better integrate information from third parties. TI has taken and continues to take reasonable steps to provide representative and accurate information but may not have conducted destructive testing or chemical analysis on incoming materials and chemicals. TI and TI suppliers consider certain information to be proprietary, and thus CAS numbers and other limited information may not be available for release.

In no event shall TI's liability arising out of such information exceed the total purchase price of the TI part(s) at issue in this document sold by TI to Customer on an annual basis.

TAPE AND REEL INFORMATION

QUADRANT ASSIGNMENTS FOR PIN 1 ORIENTATION IN TAPE

*All dimensions are nominal

Device	Package Type	Package Drawing	Pins	SPQ	Reel Diameter (mm)	Reel Width W1 (mm)	A0 (mm)	B0 (mm)	K0 (mm)	P1 (mm)	W (mm)	Pin1 Quadrant
SN74LVCH16543ADGGR	TSSOP	DGG	56	2000	330.0	24.4	8.6	15.6	1.8	12.0	24.0	Q1
SN74LVCH16543ADLR	SSOP	DL	56	1000	330.0	32.4	11.35	18.67	3.1	16.0	32.0	Q1

TAPE AND REEL BOX DIMENSIONS

*All dimensions are nominal

Device	Package Type	Package Drawing	Pins	SPQ	Length (mm)	Width (mm)	Height (mm)
SN74LVCH16543ADGGR	TSSOP	DGG	56	2000	367.0	367.0	45.0
SN74LVCH16543ADLR	SSOP	DL	56	1000	367.0	367.0	55.0

MECHANICAL DATA

DL (R-PDSO-G56)

PLASTIC SMALL-OUTLINE PACKAGE



- NOTES:
- A. All linear dimensions are in inches (millimeters).
 - B. This drawing is subject to change without notice.
 - C. Body dimensions do not include mold flash or protrusion not to exceed 0.006 (0,15).
 - D. Falls within JEDEC MO-118

PowerPAD is a trademark of Texas Instruments.



4222167/A 07/2015

NOTES:

1. All linear dimensions are in millimeters. Any dimensions in parenthesis are for reference only. Dimensioning and tolerancing per ASME Y14.5M.
2. This drawing is subject to change without notice.
3. This dimension does not include mold flash, protrusions, or gate burrs. Mold flash, protrusions, or gate burrs shall not exceed 0.15 mm per side.
4. Reference JEDEC registration MO-153.

EXAMPLE BOARD LAYOUT

DGG0056A

TSSOP - 1.2 mm max height

SMALL OUTLINE PACKAGE



LAND PATTERN EXAMPLE
SCALE:6X



SOLDER MASK DETAILS

4222167/A 07/2015

NOTES: (continued)

- 5. Publication IPC-7351 may have alternate designs.
- 6. Solder mask tolerances between and around signal pads can vary based on board fabrication site.

EXAMPLE STENCIL DESIGN

DGG0056A

TSSOP - 1.2 mm max height

SMALL OUTLINE PACKAGE



SOLDER PASTE EXAMPLE
BASED ON 0.125 mm THICK STENCIL
SCALE:6X

4222167/A 07/2015

NOTES: (continued)

7. Laser cutting apertures with trapezoidal walls and rounded corners may offer better paste release. IPC-7525 may have alternate design recommendations.
8. Board assembly site may have different recommendations for stencil design.

IMPORTANT NOTICE AND DISCLAIMER

TI PROVIDES TECHNICAL AND RELIABILITY DATA (INCLUDING DATASHEETS), DESIGN RESOURCES (INCLUDING REFERENCE DESIGNS), APPLICATION OR OTHER DESIGN ADVICE, WEB TOOLS, SAFETY INFORMATION, AND OTHER RESOURCES "AS IS" AND WITH ALL FAULTS, AND DISCLAIMS ALL WARRANTIES, EXPRESS AND IMPLIED, INCLUDING WITHOUT LIMITATION ANY IMPLIED WARRANTIES OF MERCHANTABILITY, FITNESS FOR A PARTICULAR PURPOSE OR NON-INFRINGEMENT OF THIRD PARTY INTELLECTUAL PROPERTY RIGHTS.

These resources are intended for skilled developers designing with TI products. You are solely responsible for (1) selecting the appropriate TI products for your application, (2) designing, validating and testing your application, and (3) ensuring your application meets applicable standards, and any other safety, security, or other requirements. These resources are subject to change without notice. TI grants you permission to use these resources only for development of an application that uses the TI products described in the resource. Other reproduction and display of these resources is prohibited. No license is granted to any other TI intellectual property right or to any third party intellectual property right. TI disclaims responsibility for, and you will fully indemnify TI and its representatives against, any claims, damages, costs, losses, and liabilities arising out of your use of these resources.

TI's products are provided subject to TI's Terms of Sale (www.ti.com/legal/termsofsale.html) or other applicable terms available either on ti.com or provided in conjunction with such TI products. TI's provision of these resources does not expand or otherwise alter TI's applicable warranties or warranty disclaimers for TI products.

Mailing Address: Texas Instruments, Post Office Box 655303, Dallas, Texas 75265
Copyright © 2019, Texas Instruments Incorporated

Looking for pricing, stock, or lifecycle information?

Click below to explore more details on WIN SOURCE:

 [View SN74LVCH16543ADGVR on WIN SOURCE](#)

 [Texas Instruments](#) Information

Optimize Your Supply Chain with WIN SOURCE Solutions

-  Global Sourcing Solution
-  Obsolete Management
-  Cost Control Management
-  Shortage Management
-  Alternative Solution
-  Excess Inventory Management