



THE DATASHEET OF BCY59IX



SMALL SIGNAL NPN TRANSISTOR

DESCRIPTION

The BCY59 is a silicon Planar Epitaxial NPN transistor in Jedec TO-18 metal case. It is intended for use in audio input stages, driver stages and low-noise input stages.

The PNP complementary type is BCY79.

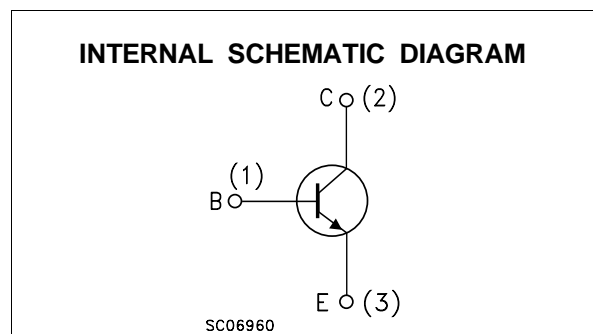
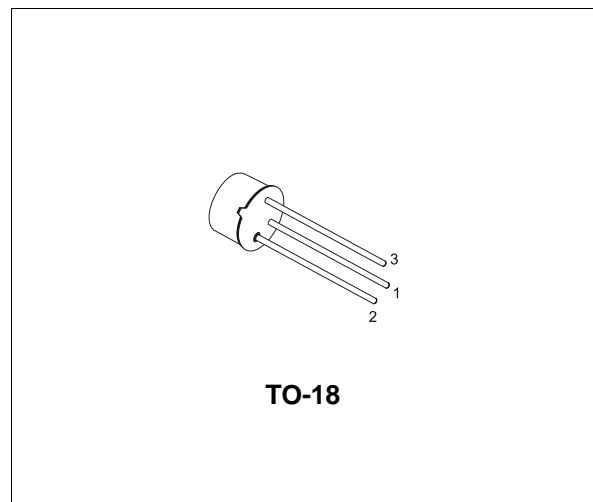

ABSOLUTE MAXIMUM RATINGS

Symbol	Parameter	Value	Unit
V_{CES}	Collector-Emitter Voltage ($V_{BE} = 0$)	45	V
V_{CEO}	Collector-Emitter Voltage ($I_B = 0$)	45	V
V_{EBO}	Emitter-Base Voltage ($I_C = 0$)	7	V
I_C	Collector Current	200	mA
I_B	Base Current	50	mA
P_{tot}	Total Dissipation at $T_{amb} \leq 25\text{ }^\circ\text{C}$ at $T_C \leq 25\text{ }^\circ\text{C}$	0.39 1	W W
T_{stg}	Storage Temperature	-55 to 175	$^\circ\text{C}$
T_j	Max. Operating Junction Temperature	175	$^\circ\text{C}$

BCY59

THERMAL DATA

R _{thj-case}	Thermal Resistance Junction-Case	Max	150	°C/W
R _{thj-amb}	Thermal Resistance Junction-Ambient	Max	384.6	°C/W

ELECTRICAL CHARACTERISTICS (T_{case} = 25 °C unless otherwise specified)

Symbol	Parameter	Test Conditions	Min.	Typ.	Max.	Unit
I _{CES}	Collector Cut-off Current (V _{BE} = 0)	V _{CE} = 45 V		0.1	10	nA
		V _{CE} = 45 V T _C = 150 °C		0.1	10	μA
I _{CEX}	Collector Cut-off Current (V _{BE} = -0.2 V)	V _{CE} = 45 V T _C = 100 °C			20	μA
I _{EBO}	Emitter Cut-off Current (I _C = 0)	V _{EB} = 5 V			10	nA
V _{(BR)CEO*}	Collector-Emitter Breakdown Voltage (I _B = 0)	I _C = 2 mA	45			V
V _{(BR)EBO}	Emitter-Base Breakdown Voltage (I _C = 0)	I _E = 10 μA	7			V
V _{CE(sat)*}	Collector-Emitter Saturation Voltage	I _C = 10 mA I _B = 0.25 mA		0.12	0.35	V
		I _C = 100 mA I _B = 2.5 mA		0.4	0.7	V
V _{BE(sat)*}	Base-Emitter Saturation Voltage	I _C = 10 mA I _B = 0.25 mA	0.6	0.7	0.85	V
		I _C = 100 mA I _B = 2.5 mA	0.75	0.9	1.2	V
V _{BE(on)*}	Base-Emitter (on) Voltage	I _C = 2 mA V _{CE} = 5 V	0.55	0.65	0.7	V
		I _C = 100 mA V _{CE} = 1 V		0.75		V
h _{FE*}	DC Current Gain	I _C = 10 μA V _{CE} = 5 V	Gr. VIII	20	140	
			Gr. IX	40	195	
			Gr. X	100	280	
		I _C = 2 mA V _{CE} = 5 V	Gr. VIII	180	250	310
			Gr. IX	250	350	460
			Gr. X	380	500	630
		I _C = 10 mA V _{CE} = 1 V	Gr. VIII	120	260	
			Gr. IX	160	365	
			Gr. X	240	520	
		I _C = 100 mA V _{CE} = 1 V	Gr. VIII	45		
			Gr. IX	60		
			Gr. X	60		
h _{fe*}	Small Signal Current Gain	I _C = 2 mA V _{CE} = 5 V f = 1 KHz	Gr. VIII	175	350	
			Gr. IX	250	500	
			Gr. X	350	700	
f _T	Transition Frequency	I _C = 10 mA V _{CE} = 5 V f = 100 MHz		200		MHz

* Pulsed: Pulse duration = 300 μs, duty cycle ≤ 1 %

ELECTRICAL CHARACTERISTICS ($T_{case} = 25\text{ }^{\circ}\text{C}$ unless otherwise specified)

Symbol	Parameter	Test Conditions	Min.	Typ.	Max.	Unit
C_{CBO}	Collector-Base Capacitance	$I_E = 0$ $V_{CB} = 10\text{ V}$ $f = 1\text{ MHz}$		3.5	6	pF
C_{EBO}	Emitter-Base Capacitance	$I_C = 0$ $V_{EB} = 0.5\text{ V}$ $f = 1\text{ MHz}$		11	15	pF
NF	Noise Figure	$I_C = 0.2\text{ mA}$ $V_{CE} = 5\text{ V}$ $f = 1\text{ KHz}$ $R_g = 2\text{ K}\Omega$ $\Delta f = 200\text{ Hz}$		2	6	dB
t_{on}	Turn-on Time	$I_C = 10\text{ mA}$ $V_{CC} = 10\text{ V}$ $I_{B1} = 1\text{ mA}$ $I_C = 100\text{ mA}$ $V_{CC} = 10\text{ V}$ $I_{B1} = 10\text{ mA}$		85	150	ns
t_{off}	Turn-off Time	$I_C = 10\text{ mA}$ $V_{CC} = 10\text{ V}$ $I_{B1} = -I_{B2} = 1\text{ mA}$ $I_C = 100\text{ mA}$ $V_{CC} = 10\text{ V}$ $I_{B1} = -I_{B2} = 10\text{ mA}$		480	800	ns
				480	800	ns

DC Current Gain

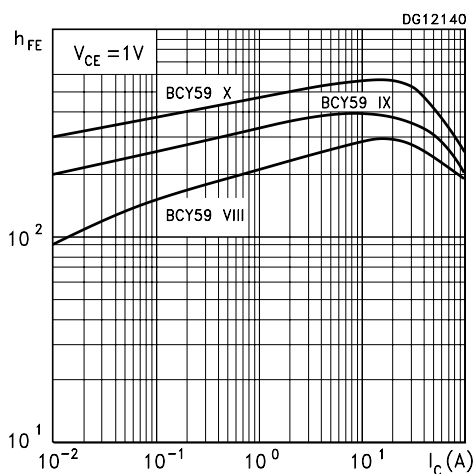

Collector-Emitter Saturation Voltage

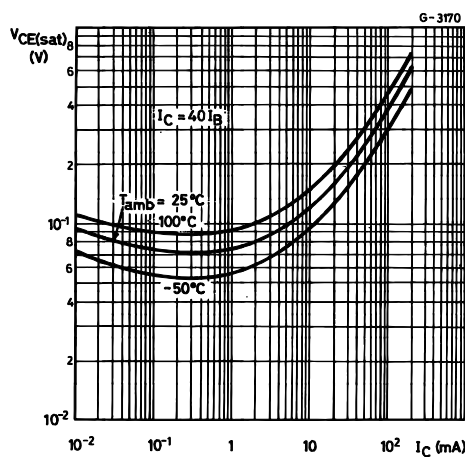

Transition Frequency

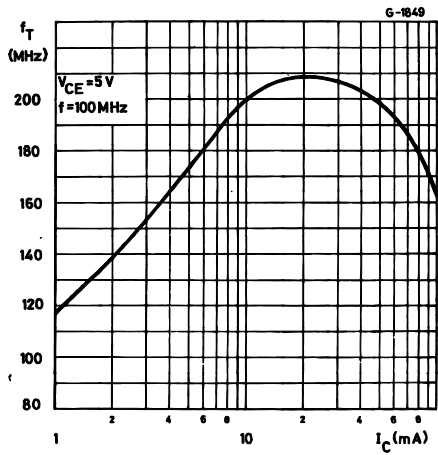

Collector-Base Capacitance

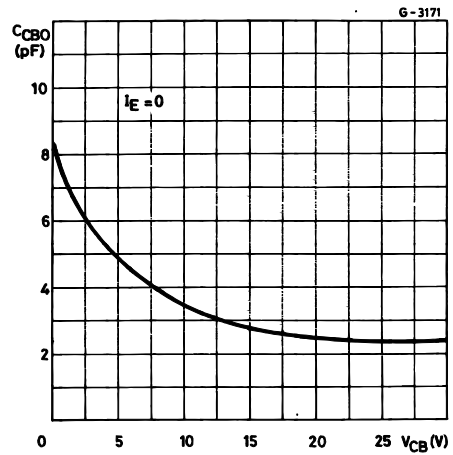

Noise Figure (f = 100 Hz)

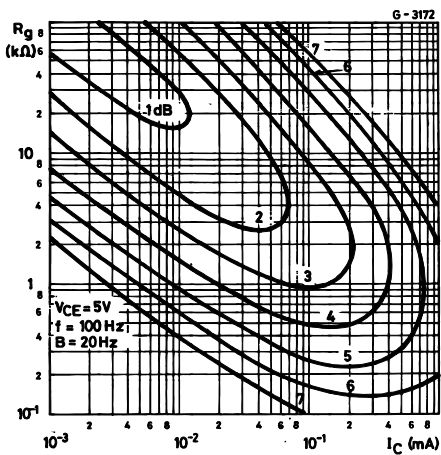

Noise Figure (f = 1 KHz)

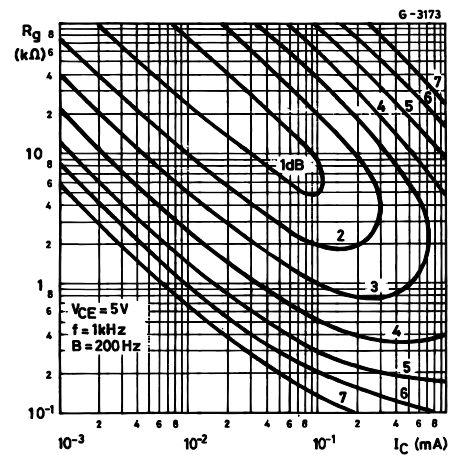

Noise Figure (f = 10 KHz)

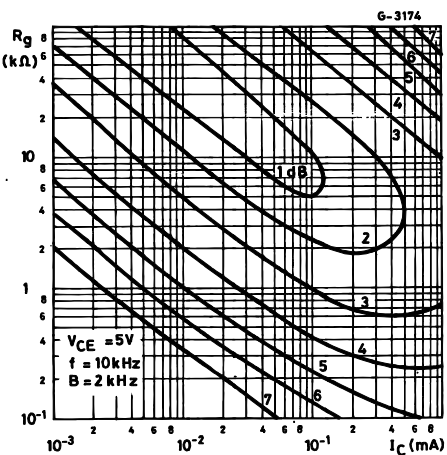

Noise Figure vs. Frequency

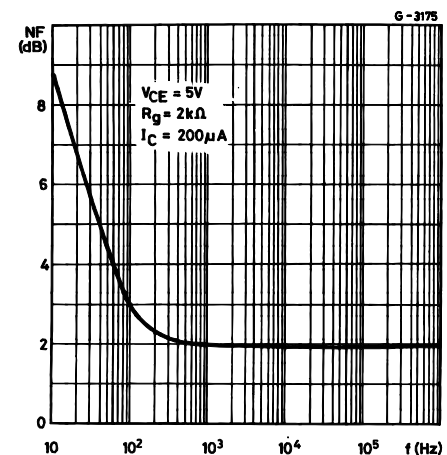

TO-18 MECHANICAL DATA

DIM.	mm			inch		
	MIN.	TYP.	MAX.	MIN.	TYP.	MAX.
A		12.7			0.500	
B			0.49			0.019
D			5.3			0.208
E			4.9			0.193
F			5.8			0.228
G	2.54			0.100		
H			1.2			0.047
I			1.16			0.045
L	45°			45°		

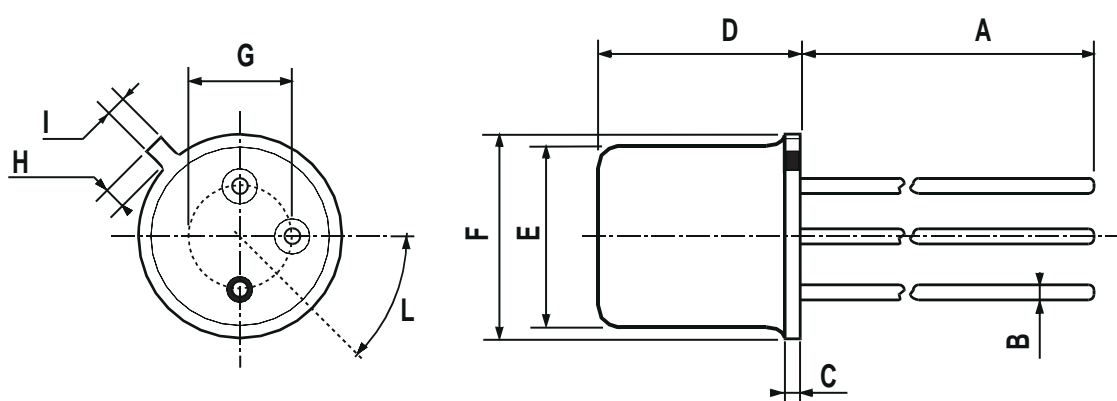

0016043

Information furnished is believed to be accurate and reliable. However, STMicroelectronics assumes no responsibility for the consequences of use of such information nor for any infringement of patents or other rights of third parties which may result from its use. No license is granted by implication or otherwise under any patent or patent rights of STMicroelectronics. Specification mentioned in this publication are subject to change without notice. This publication supersedes and replaces all information previously supplied. STMicroelectronics products are not authorized for use as critical components in life support devices or systems without express written approval of STMicroelectronics.

The ST logo is a trademark of STMicroelectronics

© 2002 STMicroelectronics – Printed in Italy – All Rights Reserved



STMicroelectronics GROUP OF COMPANIES

Australia - Brazil - Canada - China - Finland - France - Germany - Hong Kong - India - Israel - Italy - Japan - Malaysia - Malta - Morocco - Singapore - Spain - Sweden - Switzerland - United Kingdom - United States.

<http://www.st.com>

Looking for pricing, stock, or lifecycle information?

Click below to explore more details on WIN SOURCE:

-  [View BCY59IX](#) on WIN SOURCE
-  [STMicroelectronics](#) Information

Optimize Your Supply Chain with WIN SOURCE Solutions

-  Global Sourcing Solution
-  Obsolete Management
-  Cost Control Management
-  Shortage Management
-  Alternative Solution
-  Excess Inventory Management