



THE DATASHEET OF NR131S



NR131S

General Descriptions

The NR131S is buck regulator ICs integrates High-side power MOSFETs. With the current mode control, ultra low ESR capacitors such as ceramic capacitors can be used. The ICs can realize super-high efficiency by performing pulse skip operation at light load condition. The ICs have protection functions such as Over-Current Protection (OCP), Under-Voltage Lockout (UVLO) and Thermal Shutdown (TSD). Soft starting time can be set up by selecting an external capacitor value. The ON/OFF pin (EN Pin) turns the regulator on or off and helps to achieve low power consumption requirements. The NR131S is available in an 8-pin SOIC package.

Features & Benefits

- Current mode PWM control
- Up to 94% efficiency at normal load condition
- Up to 85% efficiency at light load condition
- Stable with low ESR ceramic output capacitors
- Built-in protection function
 - Over Current Protection (OCP)
 - Thermal Shutdown (TSD)
 - Under Voltage Lockout (UVLO)
- Built-in phase compensation
- Adjustable Soft-Start with an external capacitor
- Turn ON/OFF the regulator function
 - Programable Pulse-Skip operation

Package

- SOIC8

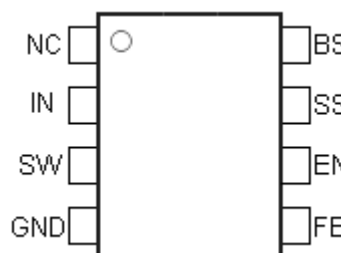
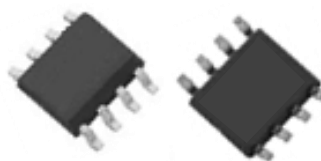

Electrical Characteristics

- 3A Continuous output current
- Operating input range $V_{IN} = 4.5V \sim 17V$
- Output adjustable $V_O = 0.8V \sim 14V$
- Fixed 350kHz frequency

Applications

- LCD TV / Blue-ray / Set top box
- Green electronic products
- Other power supply

Typical Application Circuit

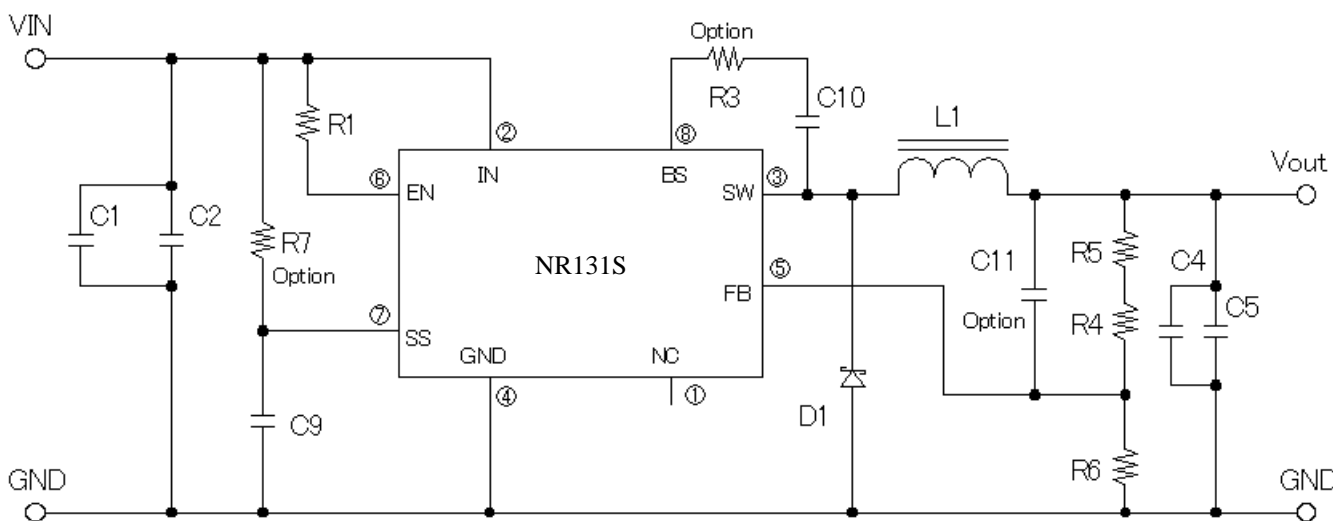

C1, C2: 10 μ F / 25V, C4, C5: 22 μ F / 16V, C7: 0.1 μ F, C9: 1800pF, C11: 220pF(Option), R1: 510k Ω , R3: 10 Ω , R4: 36 k Ω , R5: 27k Ω (VO=5.0V), R6: 12k Ω , R7: 510k Ω (Option), D1: S1PJ-L4, L1: 10 μ H

NR131S

Jul./09/2015

Series Lineup

Product Name	f _{sw}	V _{IN}		V _O		I _O	Pin No.1 Function	Pin No.2 Function	Package
NR131S	350kHz	4.5V to 17V	(1)	0.8V to 14V	(2)	3A	NC	IN	SOIC8

(1) The minimum input voltage shall be either of 4.5V or VO+3V, whichever is higher.

(2) The I/O condition limited by the Minimum on-time (TON(MIN)).

Absolute Maximum Ratings

Parameter	Symbol	Ratings	Units	Conditions
DC input voltage	V _{IN}	-0.3~19	V	
BS terminal voltage	V _{BS}	-0.3~25	V	
BS-SW Pin voltage	V _{BS-SW}	-0.3~6.0	V	DC
		-0.3~7.5		Pulse width ≤ 30ns
SW terminal voltage	V _{SW}	-2~19	V	DC
		-4.5~19		Pulse width ≤ 30ns
FB terminal voltage	V _{FB}	-0.3~5.5	V	
EN terminal voltage	V _{EN}	-0.3~19	V	
SS terminal voltage	V _{SS}	-0.3~7.4	V	
SS terminal allowable input current	I _{ssb}	5	mA	
Power dissipation	(3) P _{DI}	1.42	W	Glass-epoxy board mounting in a 40×40mm. (copper area in a 25×25mm) Max T _J =150°C
Junction temperature	(4) T _J	-40 ~ 150	°C	
Storage temperature	T _S	-40 ~ 150	°C	
Thermal resistance (junction- Pin No. 4)	θ _{JP}	60.8	°C/W	
Thermal resistance (junction-ambient air)	θ _{JA}	88.2	°C/W	Glass-epoxy board mounting in a 40×40mm. (copper area in a 25×25mm)

(3) Limited by thermal shutdown.

(4) The temperature detection of thermal shutdown is about 165°C

Recommended Operating Conditions

Parameter	Symbol	Ratings		Units	Conditions
		MIN	MAX		
DC input voltage	(5) V _{IN}	V _o +3	17	V	
DC output current	(6) I _O	0	3.0	A	
Output voltage	(7) V _O	0.8	14	V	
Ambient operating temperature	(7) T _{OP}	-40	85	°C	

(5) The minimum value of input voltage is taken as the larger one of either 4.5V or V_O +3V.

In the case of V_{IN}=V_O+1~V_O+3V, it is set to I_O=Max. 2A

(6) Recommended circuit refers to Typical Application Circuit.

(7) To be used within the allowable package power dissipation characteristics.

NR131S

Jul./09/2015

Electrical Characteristics

Ta = 25°C

Parameter		Symbol	Ratings			Units	Test conditions
			MIN	TYP	MAX		
Reference voltage		V_{REF}	0.780	0.800	0.820	V	$V_{IN} = 12V, I_o = 1.0A$
Output voltage temperature coefficient		$\Delta V_{REF}/\Delta T$		± 0.05		mV/°C	$V_{IN} = 12V, I_o = 1.0A$ -40°C to +85°C
Switching frequency		f_{SW}	245	350	455	kHz	$V_{IN}=12V, V_o=5.0V,$ $I_o=1A$
Line regulation		⁽⁸⁾ V_{Line}		10		mV	$V_{IN} = 8V \sim 17V,$ $V_o = 5.0V, I_o = 1A$
Load regulation		⁽⁸⁾ V_{Load}		70		mV	$V_{IN} = 12V, V_o = 5.0V,$ $I_o = 0.1A \sim 2.0A$
Over current protection threshold		I_S	3.1	4.5		A	$V_{IN} = 12V, V_o = 5.0V$
Supply Current(Non-switching)		I_{IN}		100		μA	$V_{IN}= 12V, V_{EN}=12V$
Shutdown Supply Current		$I_{IN(off)}$		1		μA	$V_{IN}=12V, V_{EN}=0V$
Input Under Voltage Lockout threshold		V_{uvlo}		3.9	4.4	V	V_{IN} Rising
SS Pin	Charging current	I_{SS}	13	22	31	μA	$V_{SS}=0V, V_{IN}=12V$
EN Pin	Sink current	I_{EN}		5	10	μA	$V_{EN}= 12V$
	Threshold voltage	V_{EN}	0.7	1.3	2.1	V	$V_{IN}=12V$
Max on-duty		⁽⁸⁾ D_{MAX}		90		%	$V_{IN}=12V$
Minimum on-time		⁽⁸⁾ $T_{ON(MIN)}$		170		nsec	$V_{IN}=12V$
Thermal shutdown threshold temperature		⁽⁸⁾ TSD	151	165		°C	$V_{IN}=12V$
Thermal shutdown restart hysteresis of temperature		⁽⁸⁾ TSD_{hys}		15		°C	$V_{IN}=12V$

⁽⁸⁾ Guaranteed by design, not tested.

NR131S

Typical Performance Characteristics

NR131S typical Performance Characteristics

(1)Efficiency

Condition: $V_o=3.3V$

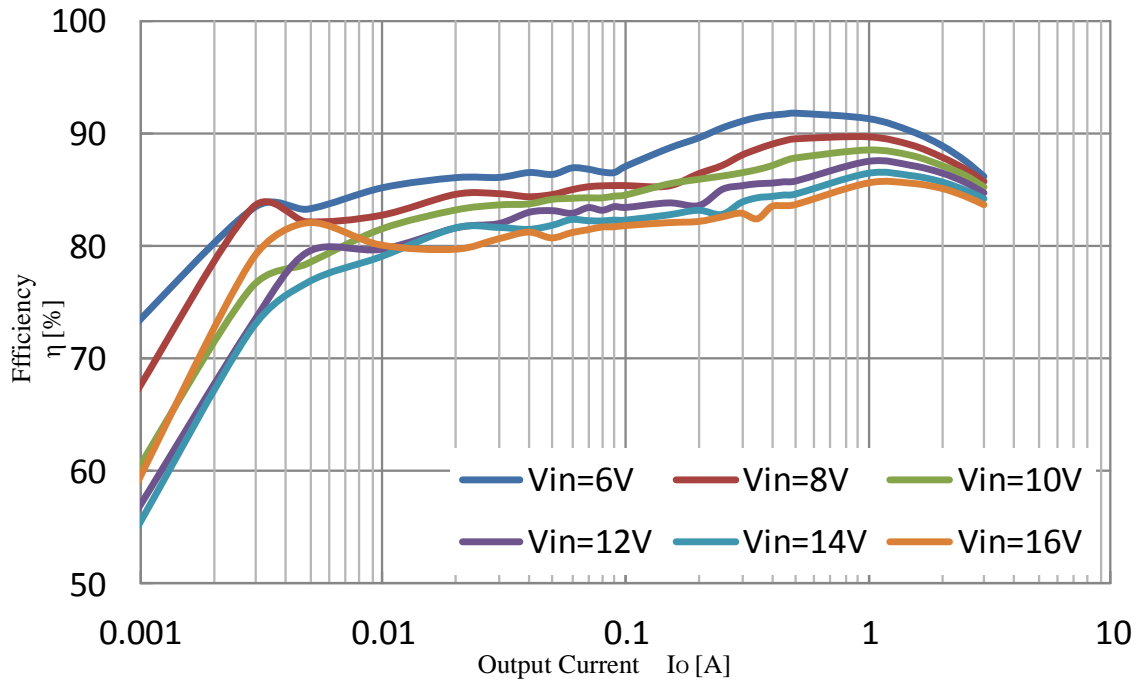

Condition: $V_o=5.0V$

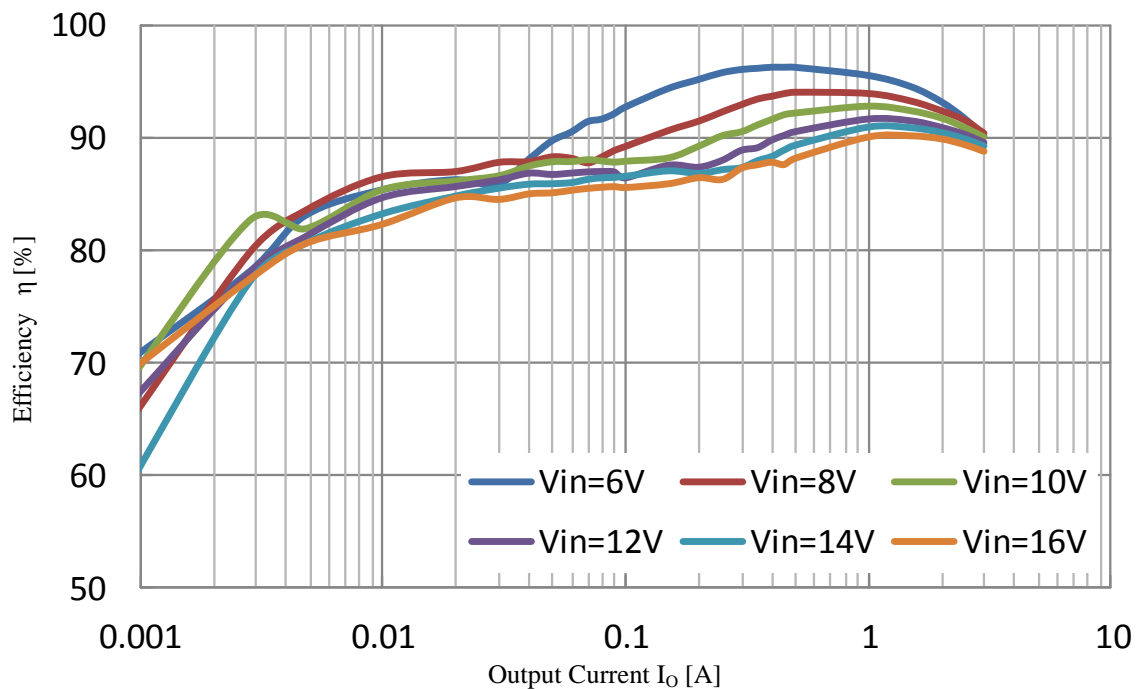

NR131S

(2) Output startup Io=1A

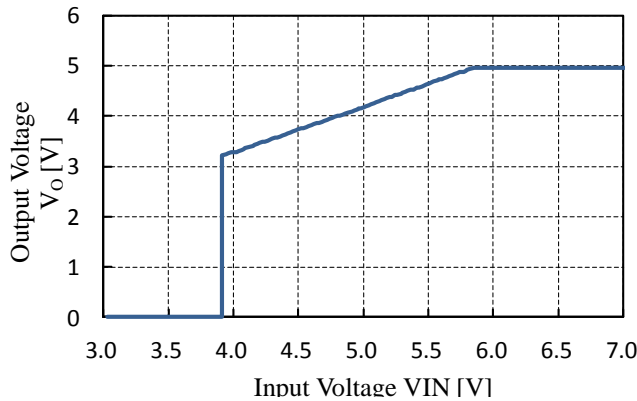

(5) Over Current Protection

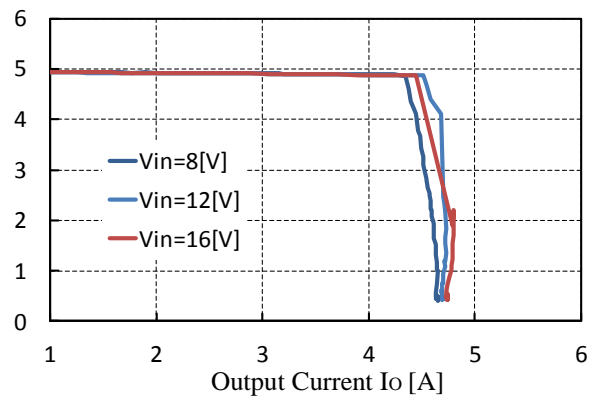

(3) Load Regulation : V_{Load}

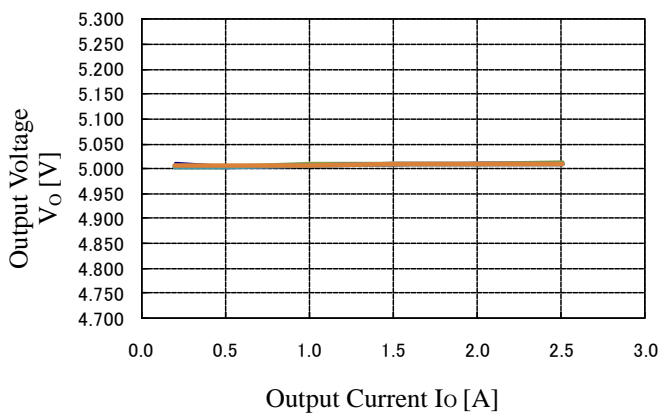

(6) Supply Current : I_{IN}

V_O=5.0V

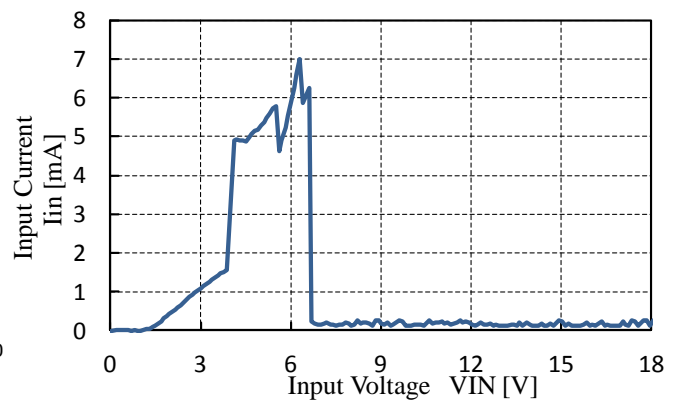

(4) Shutdown Supply Current : I_{IN(off)}

V_{EN}=0V

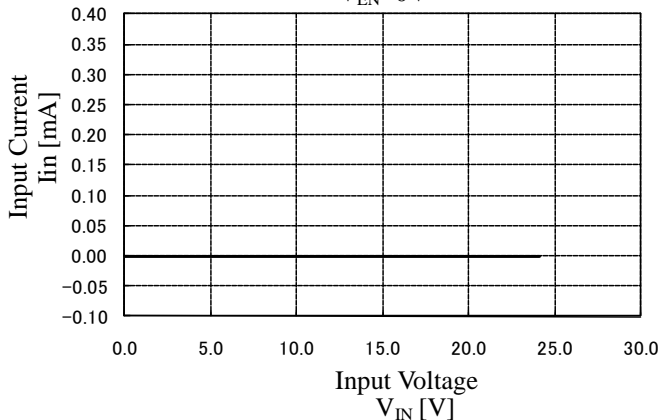

(7) Switching Frequency: f_{sw}

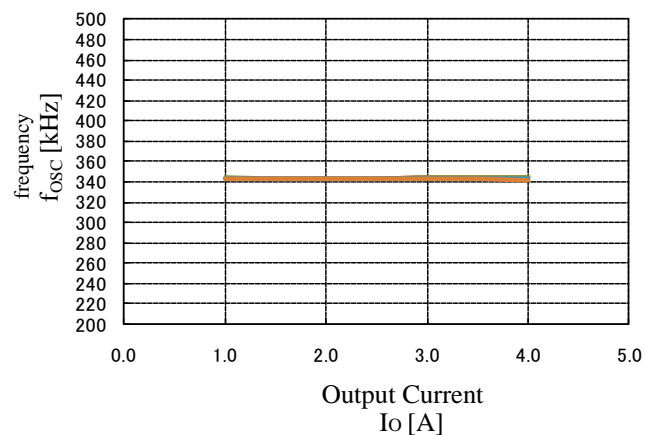

NR131S

Functional Block Diagram

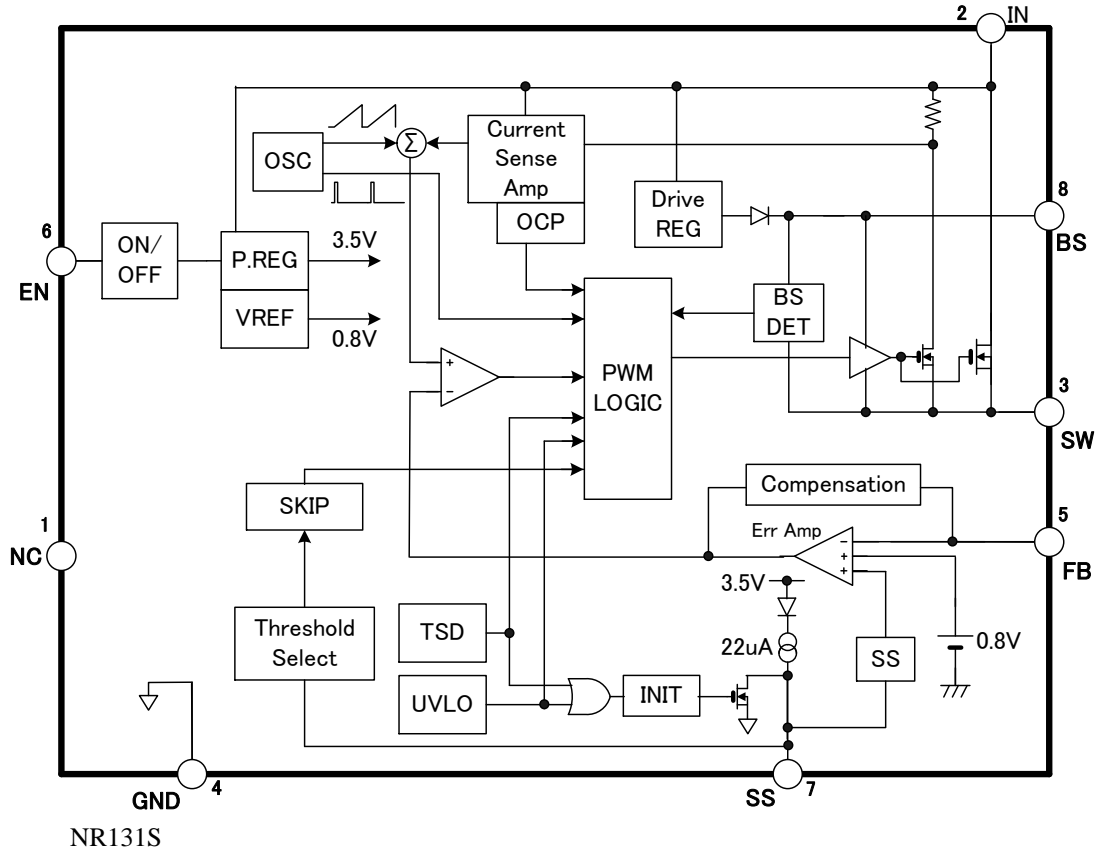

NR131S

Jul./09/2015

Pin Assignments & Functions

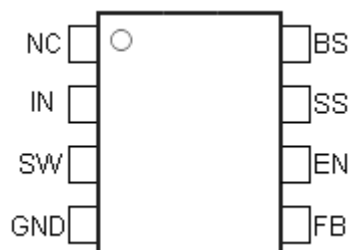

Pin Assignments

Pin assignments & functions of NR131S

Pin No.	Symbol	Description
1	NC	No Connection.(NC)
2	IN	Power input. VIN supplies the power to the IC.as well as the regulator switches
3	SW	Power switching output. SW supplies power to the output. Connect the LC filter from SW to the output. Connect a Schottky Barrier Diode between SW and GND. Note that a capacitor is required from SW to BS to supply the power the High-side switch
4	GND	Ground Connect the exposed pad to Pin No.4
5	FB	Feedback input Pin to compare Reference Voltage. The feedback threshold is 0.8V. To set the output voltage, FB Pin is required to connect between resistive voltage divider R4 and R6.
6	EN	Enable input. Drive EN Pin high to turn on the regulator, low to turn it off.
7	SS	Soft-Start and SKIP operation control input. To set the soft-start period, connect to a capacitor between GND. To set the Low Ripple SKIP operation, add the resistor 510k ohm between SS terminal and IN terminal.
8	BS	High-side Boost input. BS supplies the drive for High-side Nch-MOSFET switch. Connect a capacitor and a resistor between SW to BS.

Example Application Circuit

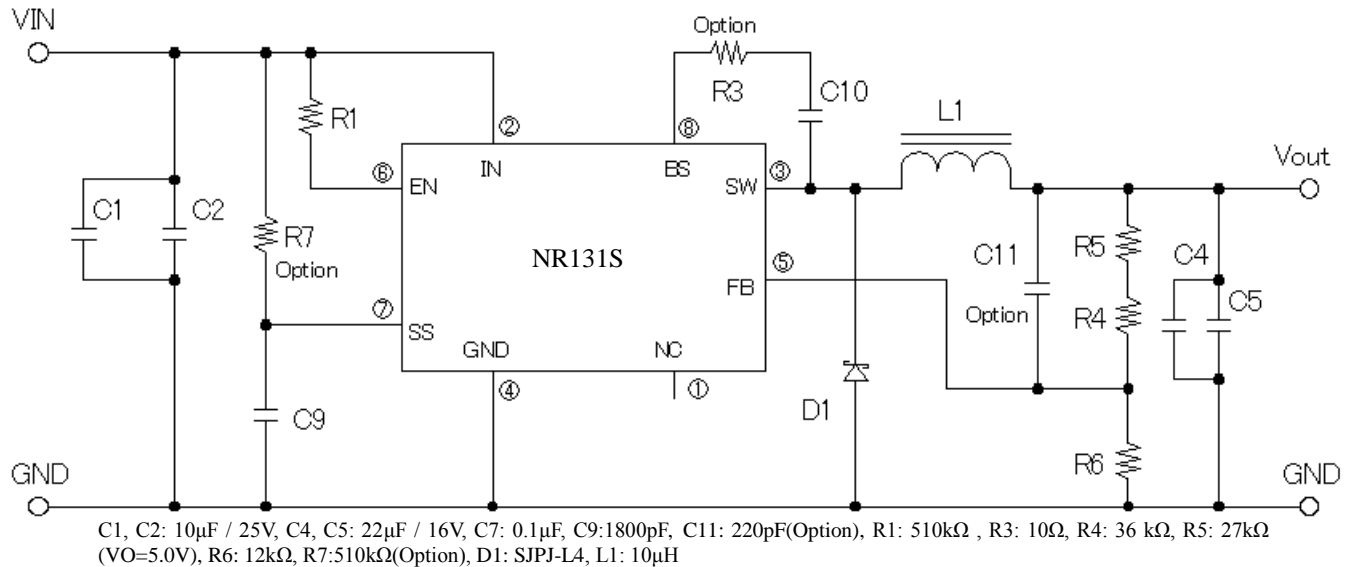

A design guide for add-on parts around of the NR131S.

(1)Diode D1

- The schottky-barrier diode must be used for D1. If other diodes like fast recovery diodes are used, IC may be damaged because of the reverse voltage applied by the recovery voltage or ON voltage.

(2)Choke coil L1

- If the winding resistance of the choke coil is too high, the efficiency may go down to the extent that it is out of the rating.
- As the start current of the over current protection is approximately 4A, attention must be paid to the heating of the choke coil by the magnetic saturation due to overload or short-circulated load.

(3)Capacitor C1(C2), C4(C5), C9

- As large ripple current across C1 (C2) and C4 (C5), capacitors with high frequency and low impedance for SMPS must be used. Especially when the impedance of C4 (C5) is high, the switching waveform may not be normal at low temperature.
- C9 is a capacitor for soft start. In case soft start function is not used, please keep Pin No.2 open.

(4)Resistor R1, R2

- R4, R5, R6 are resistor to the Output Voltage. In case of the $I(ADJ) = 66 \mu A$, R4, R5, R6 are calculated by the next equation .

$$R6 = \frac{V_{FB}}{I(ADJ)} = \frac{0.8V}{66 \mu A} = 12k\Omega$$

$$V_o = V_{FB} \left(1 + \frac{R4 + R5}{R6} \right) \Rightarrow R4 + R5 = \frac{R6 \times (V_o - V_{FB})}{V_{FB}}$$

$$R4 + R5 = \frac{12k\Omega \times (5V - 0.8V)}{0.8V} = 63k\Omega$$

$$*63k\Omega = 27k\Omega + 36k\Omega$$

In order to have optimum operating condition, each component must be connected with the minimum distance.

Allowable package power dissipation

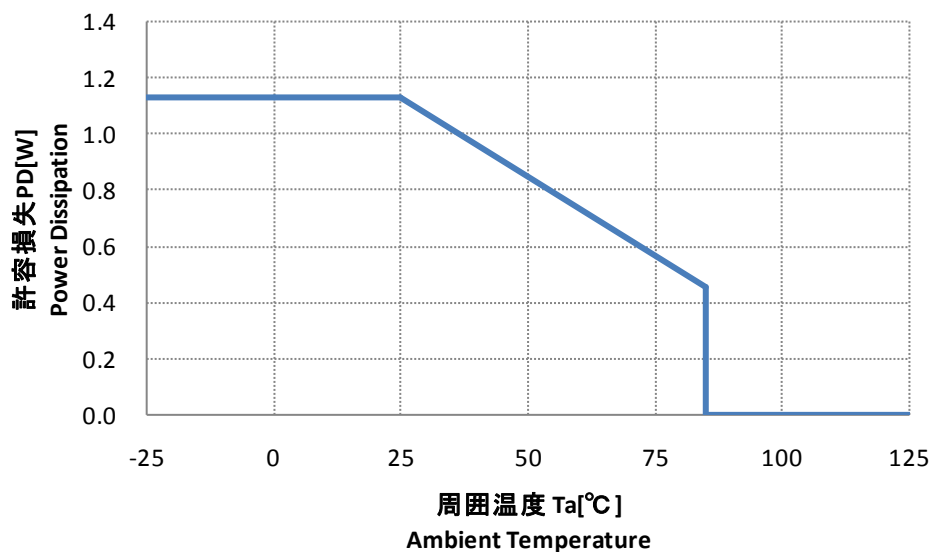

Allowable package power dissipation of NR131S

NOTES:

- 1) Glass-epoxy board mounting in a 30×30mm
- 2) copper area : 25×25mm
- 3) The power dissipation is calculated at the junction temperature 125 °C
- 4) Losses can be calculated by the following equation.
As the efficiency is subject to the input voltage and output current, it shall be obtained from the efficiency curve and substituted in percent
- 5) Thermal design for D1 shall be made separately.

$$P_D = V_O \times I_O \left(\frac{100}{\eta x} - 1 \right) \dots (1)$$

V_O: Output voltageV_{IN}: Input voltageI_O: Output current

η x : Efficiency (%)

V_f: SJPB-L4 I_o=3A/V_f=0.55V
Diode forward voltage (A to K)

NR131S

PCB layout recommendation

*The demonstration Printed circuit board. It can mount a part for the experiment ,except for the Example Application Circuit.
 *This pattern layout is for NR131A/NR131S.

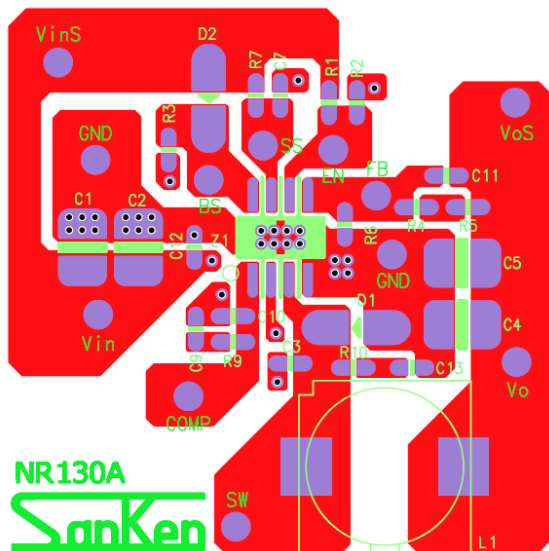

Front Side: Component Side (double sided board)

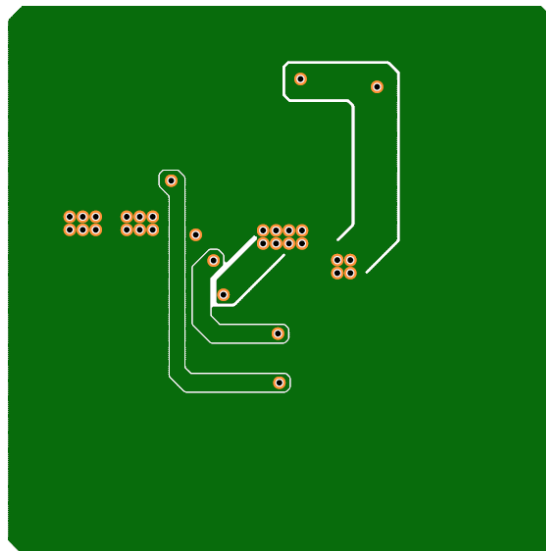

Back Side: GND Side (double sided board)

Note

- 1) Size of the PCB is about 40mm × 40mm
- 2) Dimension is in millimeters, dimension in bracket is in inches.
- 3) Drawing is not to scale.

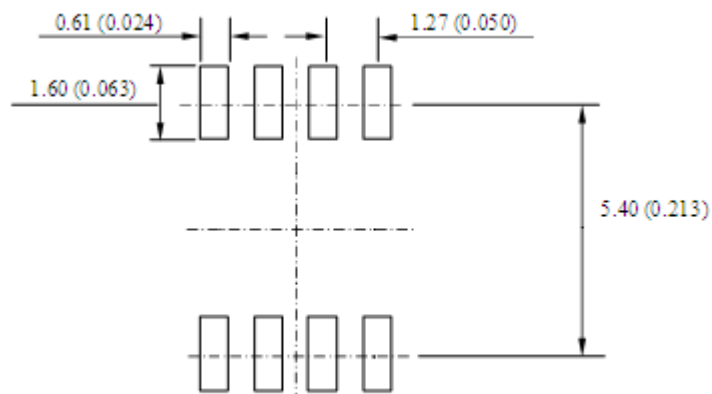

Recommended land pattern

NR131S

Jul./09/2015

Package outline, dimensions

SOIC8 package (Units : mm)

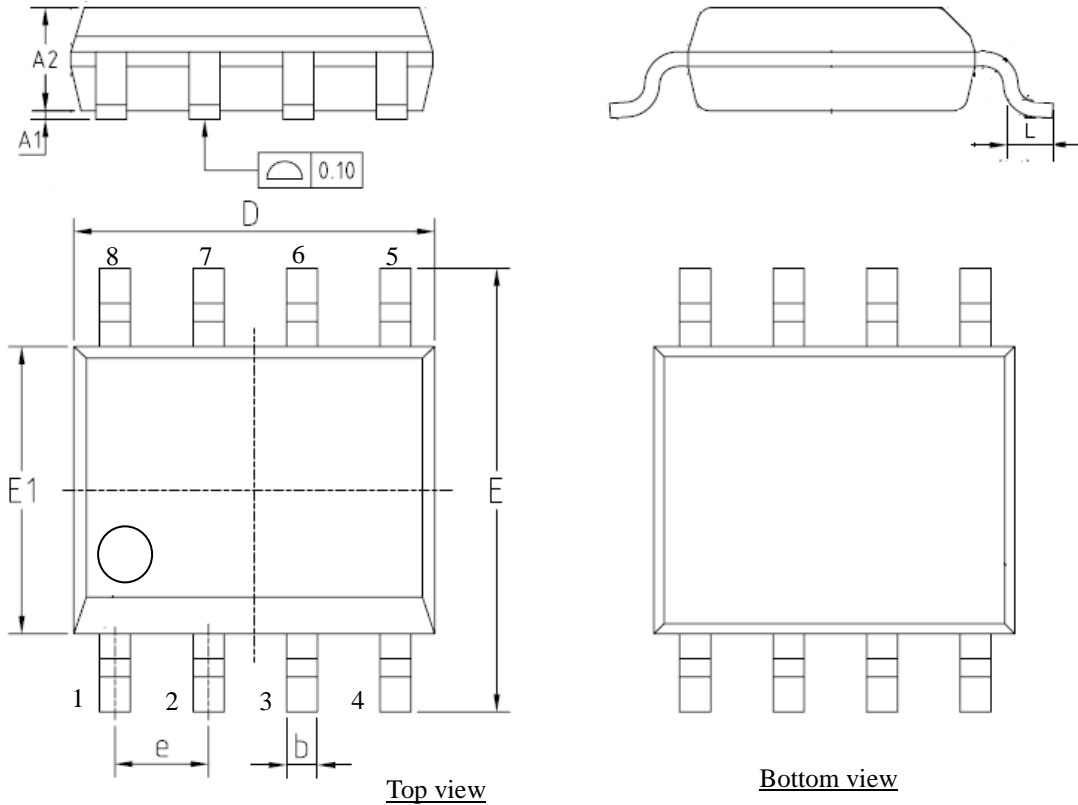

Marking

*1. Product number

NR131S

*2. Lot number (three digit)

1st letter : The last digit of the year

2nd letter : Month

January to September : 1 to 9

October : O

November : N

December : D

3rd letter : manufacturing week

First week to 5th week : 1 to 5

*3. Control number (four digit)

Symbol	Dimension is in millimeters(mm)		
	MIN	TYP	MAX
A1	0.05	0.15	0.25
A2	1.25	1.40	1.65
b	0.38	—	0.51
D	4.80	4.90	5.00
E	5.80	6.00	6.20
E1	3.80	3.90	4.00
e	—	1.27	—
L	0.45	0.6	0.8

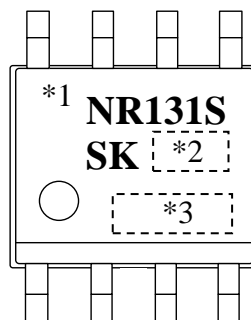

OPERATING PRECAUTIONS

Reliability can be affected adversely by improper storage environments and handling methods. Please observe the following cautions.

Heat dissipation and reliability

Thermal performance of the surface mount package IC depends on the material and area size of PCB and its copper plane. Design thermal condition with sufficient margin

Parallel operation

The parallel operation to increase the current is not available.

Thermal shut down

The NR131S has a thermal protection circuit.

This circuit protects the IC from the heat generation by the over load.

This circuit cannot guarantee the long-term reliability against the continuously over load status.

Cautions for Storage

- Ensure that storage conditions comply with the standard temperature (5 to 35°C) and the standard relative humidity (around 40 to 75%); avoid storage locations that experience extreme changes in temperature or humidity.
- Avoid locations where dust or harmful gases are present and avoid direct sunlight.
- Reinspect for rust on leads and solderability of products that have been stored for a long time.

Cautions for Testing and Handling

- When tests are carried out during inspection testing and other standard test periods, protect the products from power surges from the testing products, shorts between the product pins, and wrong connections. In addition, avoid tests exceeded ratings

Soldering

When soldering the products, please be sure to minimize the working time, within the following limits.

- Reflow Preheat ; 180°C / 90±30s
Heat ; 250°C / 10±1s (260°C peak ,2times)
- Soldering iron ; 380±10°C / 3.5±0.5s (1time)

Electrostatic Discharge



- When handling the products, the operator must be grounded. Grounded wrist straps worn should have at least 1MΩ of resistance from the operator to ground to prevent shock hazard, and it should be placed near the operator.
- Workbenches where the products are handled should be grounded and be provided with conductive table and floor mats.
- When using measuring equipment such as a curve tracer, the equipment should be grounded.
- When soldering the products, the head of a soldering irons or the solder bath must be grounded in order to prevent leak voltages generated by them from being applied to the products.
- The products should always be stored and transported in Sanken shipping containers or conductive containers, or be wrapped in aluminum foil.

IMPORTANT NOTES

- The contents in this document are subject to changes, for improvement and other purposes, without notice. Make sure that this is the latest revision of the document before use.
- Application and operation examples described in this document are quoted for the sole purpose of reference for the use of the products herein and Sanken can assume no responsibility for any infringement of industrial property rights, intellectual property rights or any other rights of Sanken or any third party which may result from its use.
- Although Sanken undertakes to enhance the quality and reliability of its products, the occurrence of failure and defect of semiconductor products at a certain rate is inevitable. Users of Sanken products are requested to take, at their own risk, preventative measures including safety design of the equipment or systems against any possible injury, death, fires or damages to the society due to device failure or malfunction.
- Sanken products listed in this document are designed and intended for the use as components in general purpose electronic equipment or apparatus (home appliances, office equipment, telecommunication equipment, measuring equipment, etc.).
When considering the use of Sanken products in the applications where higher reliability is required (transportation equipment and its control systems, traffic signal control systems or equipment, fire/crime alarm systems, various safety devices, etc.), please contact your nearest Sanken sales representative to discuss, prior to the use of the products herein.
The use of Sanken products without the written consent of Sanken in the applications where extremely high reliability is required (aerospace equipment, nuclear power control systems, life support systems, etc.) is strictly prohibited.
- In the case that you use Sanken semiconductor products or design your products by using Sanken semiconductor products, the reliability largely depends on the degree of derating to be made to the rated values. Derating may be interpreted as a case that an operation range is set by derating the load from each rated value or surge voltage or noise is considered for derating in order to assure or improve the reliability. In general, derating factors include electric stresses such as electric voltage, electric current, electric power etc., environmental stresses such as ambient temperature, humidity etc. and thermal stress caused due to self-heating of semiconductor products. For these stresses, instantaneous values, maximum values and minimum values must be taken into consideration.
In addition, it should be noted that since power devices or IC's including power devices have large self-heating value, the degree of derating of junction temperature affects the reliability significantly.
- When using the products specified herein by either (i) combining other products or materials therewith or (ii) physically, chemically or otherwise processing or treating the products, please duly consider all possible risks that may result from all such uses in advance and proceed therewith at your own responsibility.
- Anti radioactive ray design is not considered for the products listed herein.
- Sanken assumes no responsibility for any troubles, such as dropping products caused during transportation out of Sanken's distribution network.
- The contents in this document must not be transcribed or copied without Sanken's written consent.

Looking for pricing, stock, or lifecycle information?

Click below to explore more details on WIN SOURCE:

-  [View NR131S on WIN SOURCE](#)
-  [Sanken Information](#)

Optimize Your Supply Chain with WIN SOURCE Solutions

-  Global Sourcing Solution
-  Obsolete Management
-  Cost Control Management
-  Shortage Management
-  Alternative Solution
-  Excess Inventory Management