



AK4385

108dB 192kHz 24-Bit 2ch $\Delta\Sigma$ DAC

GENERAL DESCRIPTION

The AK4385 offers the perfect mix for cost and performance based audio systems. Using AKM's multi bit architecture for its modulator the AK4385 delivers a wide dynamic range while preserving linearity for improved THD+N performance. The AK4385 has full differential SCF outputs, removing the need for AC coupling capacitors and increasing performance for systems with excessive clock jitter. The 24 Bit word length and 192kHz sampling rate make this part ideal for a wide range of applications including DVD-Audio. The AK4385 is offered in a space saving 16pin TSSOP package.

FEATURES

- Sampling Rate Ranging from 8kHz to 192kHz
- 128 times Oversampling (Normal Speed Mode)
- 64 times Oversampling (Double Speed Mode)
- 32 times Oversampling (Quad Speed Mode)
- 24-Bit 8 times FIR Digital Filter
- On chip SCF
- Digital de-emphasis for 32k, 44.1k and 48kHz sampling
- Soft mute
- Digital Attenuator (Linear 256 steps)
- I/F format: 24-Bit MSB justified, 24/20/16-Bit LSB justified or I²S
- Master clock: 256fs, 384fs, 512fs, 768fs or 1152fs (Normal Speed Mode)
128fs, 192fs, 256fs or 384fs (Double Speed Mode)
128fs, 192fs (Quad Speed Mode)
- THD+N: -94dB
- Dynamic Range: 108dB
- High Tolerance to Clock Jitter
- Power supply: 4.75 to 5.25V
- Very Small Package: 16pin TSSOP (6.4mm x 5.0mm)
- AK4381 Pin Compatible

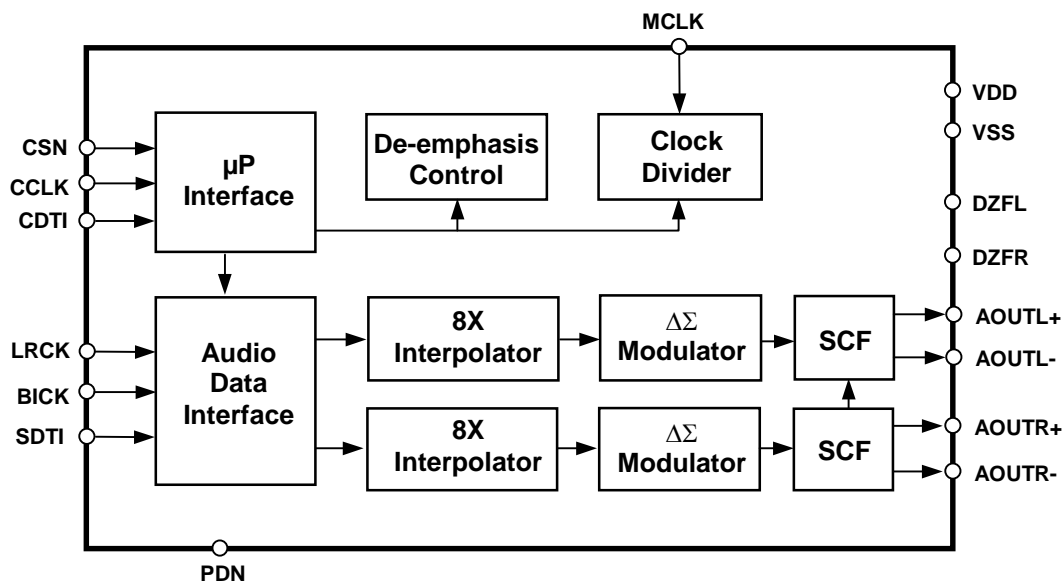

■ Ordering Guide

| | | |
|----------|-----------------------------|----------------------------|
| AK4385ET | -20 ~ +85°C | 16pin TSSOP (0.65mm pitch) |
| AK4385VT | -40 ~ +85°C | 16pin TSSOP (0.65mm pitch) |
| AKD4385 | Evaluation Board for AK4385 | |

■ Pin Layout

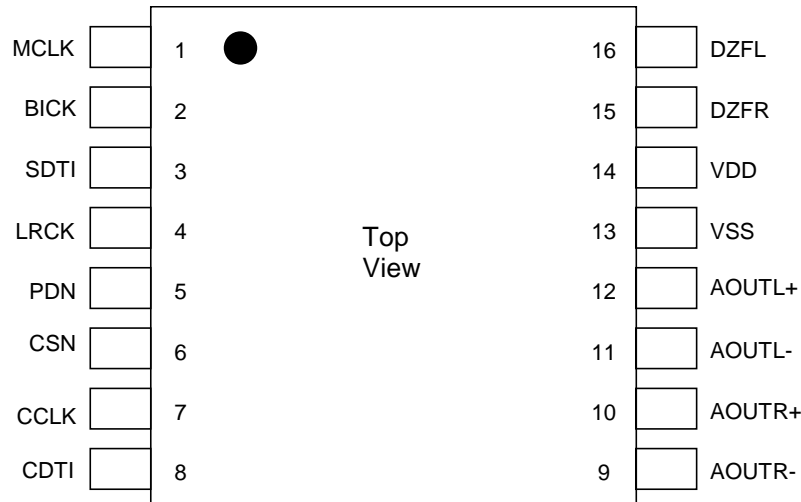

PIN/FUNCTION

| No. | Pin Name | I/O | Function |
|-----|----------|-----|--|
| 1 | MCLK | I | Master Clock Input Pin An external TTL clock should be input on this pin. |
| 2 | BICK | I | Audio Serial Data Clock Pin |
| 3 | SDTI | I | Audio Serial Data Input Pin |
| 4 | LRCK | I | L/R Clock Pin |
| 5 | PDN | I | Power-Down Mode Pin When at "L", the AK4385 is in the power-down mode and is held in reset. The AK4385 must be reset once upon power-up. |
| 6 | CSN | I | Chip Select Pin |
| 7 | CCLK | I | Control Data Input Pin |
| 8 | CDTI | I | Control Data Input Pin in serial mode |
| 9 | AOATR- | O | Rch Negative Analog Output Pin |
| 10 | AOATR+ | O | Rch Positive Analog Output Pin |
| 11 | AOATL- | O | Lch Negative Analog Output Pin |
| 12 | AOATL+ | O | Lch Positive Analog Output Pin |
| 13 | VSS | - | Ground Pin |
| 14 | VDD | - | Power Supply Pin |
| 15 | DZFR | O | Rch Data Zero Input Detect Pin |
| 16 | DZFL | O | Lch Data Zero Input Detect Pin |

Note: All input pins should not be left floating.

| |
|---------------------------------|
| ABSOLUTE MAXIMUM RATINGS |
|---------------------------------|

(VSS=0V; Note 1)

| Parameter | Symbol | min | max | Units | |
|--|----------|------|---------|-------|----|
| Power Supply | VDD | -0.3 | 6.0 | V | |
| Input Current (any pins except for supplies) | IIN | - | ±10 | mA | |
| Input Voltage | VIND | -0.3 | VDD+0.3 | V | |
| Ambient Operating Temperature (Powered applied) | AK4385ET | Ta | -20 | 85 | °C |
| | AK4385VT | Ta | -40 | 85 | °C |
| Storage Temperature | Tstg | -65 | 150 | °C | |

Note: 1. All voltages with respect to ground.

WARNING: Operation at or beyond these limits may results in permanent damage to the device.
Normal operation is not guaranteed at these extremes.

| |
|---|
| RECOMMENDED OPERATING CONDITIONS |
|---|

(VSS=0V; Note 1)

| Parameter | Symbol | min | typ | max | Units |
|--------------|--------|------|-----|------|-------|
| Power Supply | VDD | 4.75 | 5.0 | 5.25 | V |

*AKM assumes no responsibility for the usage beyond the conditions in this datasheet.

| |
|-------------------------------|
| ANALOG CHARACTERISTICS |
|-------------------------------|

(Ta=25°C; VDD=5.0V; fs=44.1kHz; BICK=64fs; Signal Frequency=1kHz; 24bit Input Data;
Measurement frequency=20Hz ~ 20kHz; R_L ≥4kΩ; unless otherwise specified)

| Parameter | | min | typ | max | Units | |
|---|------------|---------|-------|-------|-----------------|----|
| Resolution | | | | 24 | Bits | |
| Dynamic Characteristics (Note 3) | | | | | | |
| THD+N | fs=44.1kHz | 0dBFS | | -94 | -84 | dB |
| | BW=20kHz | -60dBFS | | -44 | - | dB |
| | fs=96kHz | 0dBFS | | -92 | - | dB |
| | BW=40kHz | -60dBFS | | -41 | - | dB |
| THD+N | fs=192kHz | 0dBFS | | -92 | - | dB |
| | BW=40kHz | -60dBFS | | -41 | - | dB |
| Dynamic Range (-60dBFS with A-weighted) | (Note 4) | 100 | 108 | | dB | |
| S/N (A-weighted) | (Note 5) | 100 | 108 | | dB | |
| Interchannel Isolation (1kHz) | | 90 | 110 | | dB | |
| Interchannel Gain Mismatch | | | 0.2 | 0.5 | dB | |
| DC Accuracy | | | | | | |
| Gain Drift | | | 100 | - | ppm/°C | |
| Output Voltage | (Note 6) | ±2.55 | ±2.75 | ±2.95 | V _{pp} | |
| Load Resistance | (Note 7) | 4 | | | kΩ | |
| Power Supplies | | | | | | |
| Power Supply Current (VDD) | | | | | | |
| Normal Operation (PDN = "H", fs≤96kHz) | | | 17 | 27 | mA | |
| Normal Operation (PDN = "H", fs=192kHz) | | | 20 | 32 | mA | |
| Power-Down Mode (PDN = "L") | (Note 8) | | 10 | 100 | μA | |

Notes: 3. Measured by Audio Precision (System Two). Refer to the evaluation board manual.

4. 100dB at 16bit data.

5. S/N does not depend on input bit length.

6. Full-scale voltage (0dB). Output voltage scales with the voltage of VREF,
AOUT (typ. @0dB)=(AOUT+)-(AOUT-)=±2.75V_{pp} × VREF/5.

7. For AC-load. 4kΩ for DC-load.

8. All digital inputs including clock pins (MCLK, BICK and LRCK) are held VDD or VSS.

SHARP ROLL-OFF FILTER CHARACTERISTICS

(Ta = 25°C; VDD = 4.75 ~ 5.25V; fs = 44.1kHz; DEM = OFF; SLOW = "0")

| Parameter | Symbol | min | typ | max | Units | |
|-----------------------------|------------------------------|------------|------|------------|-----------|----|
| Digital filter | | | | | | |
| Passband | $\pm 0.05\text{dB}$ (Note 9) | PB | 0 | 20.0 | kHz | |
| | -6.0dB | | - | 22.05 | kHz | |
| Stopband | (Note 9) | SB | 24.1 | | kHz | |
| Passband Ripple | | PR | | ± 0.02 | dB | |
| Stopband Attenuation | | SA | 54 | | dB | |
| Group Delay | (Note 10) | GD | - | 19.3 | 1/fs | |
| Digital Filter + SCF | | | | | | |
| Frequency Response | 20.0kHz | fs=44.1kHz | FR | - | ± 0.2 | dB |
| | 40.0kHz | fs=96kHz | FR | - | ± 0.3 | dB |
| | 80.0kHz | fs=192kHz | FR | - | +0.1/-0.6 | dB |

Notes: 9. The passband and stopband frequencies scale with fs(system sampling rate).

For example, PB=0.4535×fs (@±0.05dB), SB=0.546×fs.

10. The calculating delay time which occurred by digital filtering. This time is from setting the 16/24bit data of both channels to input register to the output of analog signal.

SLOW ROLL-OFF FILTER CHARACTERISTICS

(Ta = 25°C; AVDD, DVDD = 4.75~5.25V; fs = 44.1kHz; DEM = OFF; SLOW = "1")

| Parameter | Symbol | min | typ | max | Units | |
|-----------------------------|-------------------------------|-----------|------|-------------|---------|----|
| Digital Filter | | | | | | |
| Passband | $\pm 0.04\text{dB}$ (Note 11) | PB | 0 | 8.1 | kHz | |
| | -3.0dB | | - | 18.2 | kHz | |
| Stopband | (Note 11) | SB | 39.2 | | kHz | |
| Passband Ripple | | PR | | ± 0.005 | dB | |
| Stopband Attenuation | | SA | 72 | | dB | |
| Group Delay | (Note 10) | GD | - | 19.3 | 1/fs | |
| Digital Filter + SCF | | | | | | |
| Frequency Response | 20.0kHz | fs=44.kHz | FR | - | +0/-5 | dB |
| | 40.0kHz | fs=96kHz | FR | - | +0/-4 | dB |
| | 80.0kHz | fs=192kHz | FR | - | +0.1/-5 | dB |

Note: 11. The passband and stopband frequencies scale with fs.

For example, PB = 0.185×fs (@±0.04dB), SB = 0.888×fs.

DC CHARACTERISTICS

(Ta=25°C; VDD=4.75 ~ 5.25V)

| Parameter | Symbol | min | typ | max | Units |
|---|-----------------|---------|-----|----------|-------|
| High-Level Input Voltage | V _{IH} | 2.2 | - | - | V |
| Low-Level Input Voltage | V _{IL} | - | - | 0.8 | V |
| High-Level Output Voltage (I _{out} =-80μA) | V _{OH} | VDD-0.4 | - | - | V |
| Low-Level Output Voltage (I _{out} =80μA) | V _{OL} | - | - | 0.4 | V |
| Input Leakage Current | I _{in} | - | - | ± 10 | μA |

| |
|----------------------------------|
| SWITCHING CHARACTERISTICS |
|----------------------------------|

(Ta=25°C; VDD=4.75 ~ 5.25V)

| Parameter | Symbol | min | typ | max | Units |
|------------------------------------|-------------------|---------|---------|--------|-------|
| Master Clock Frequency | fCLK | 2.048 | 11.2896 | 36.864 | MHz |
| Duty Cycle | dCLK | 40 | | 60 | % |
| LRCK Frequency | | | | | |
| Normal Speed Mode | f _{sn} | 8 | | 48 | kHz |
| Double Speed Mode | f _{sd} | 60 | | 96 | kHz |
| Quad Speed Mode | f _{sq} | 120 | | 192 | kHz |
| Duty Cycle | Duty | 45 | | 55 | % |
| Audio Interface Timing | | | | | |
| BICK Period | | | | | |
| Normal Speed Mode | t _{BCK} | 1/128fs | | | ns |
| Double/Quad Speed Mode | t _{BCK} | 1/64fs | | | ns |
| BICK Pulse Width Low | t _{BCKL} | 30 | | | ns |
| Pulse Width High | t _{BCKH} | 30 | | | ns |
| BICK rising to LRCK Edge (Note 12) | t _{BLR} | 20 | | | ns |
| LRCK Edge to BICK rising (Note 12) | t _{LRB} | 20 | | | ns |
| SDTI Hold Time | t _{SDH} | 20 | | | ns |
| SDTI Setup Time | t _{SDS} | 20 | | | ns |
| Control Interface Timing | | | | | |
| CCLK Period | t _{CCK} | 200 | | | ns |
| CCLK Pulse Width Low | t _{CCKL} | 80 | | | ns |
| Pulse Width High | t _{CCKH} | 80 | | | ns |
| CDTI Setup Time | t _{CDS} | 40 | | | ns |
| CDTI Hold Time | t _{CDH} | 40 | | | ns |
| CSN "H" Time | t _{CSW} | 150 | | | ns |
| CSN "↓" to CCLK "↑" | t _{CSS} | 50 | | | ns |
| CCLK "↑" to CSN "↑" | t _{CSH} | 50 | | | ns |
| Reset Timing | | | | | |
| PDN Pulse Width (Note 13) | t _{PD} | 150 | | | ns |

Notes: 12. BICK rising edge must not occur at the same time as LRCK edge.

13. The AK4385 can be reset by bringing PDN= "L".

■ Timing Diagram

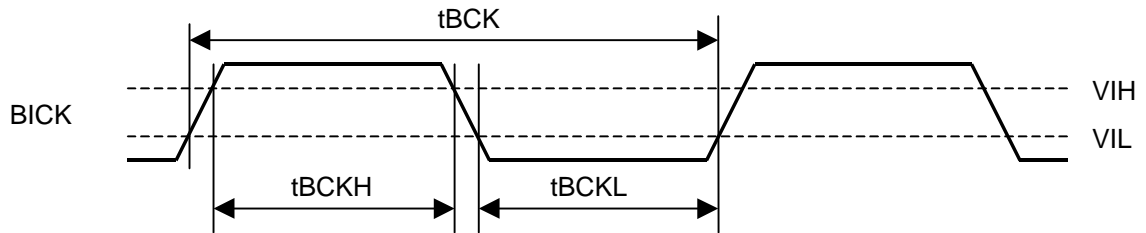
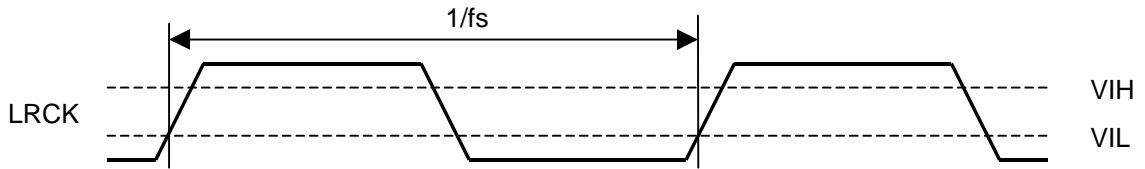
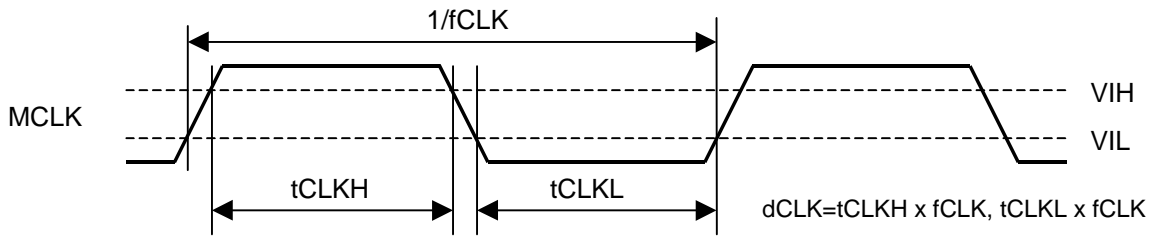

Clock Timing

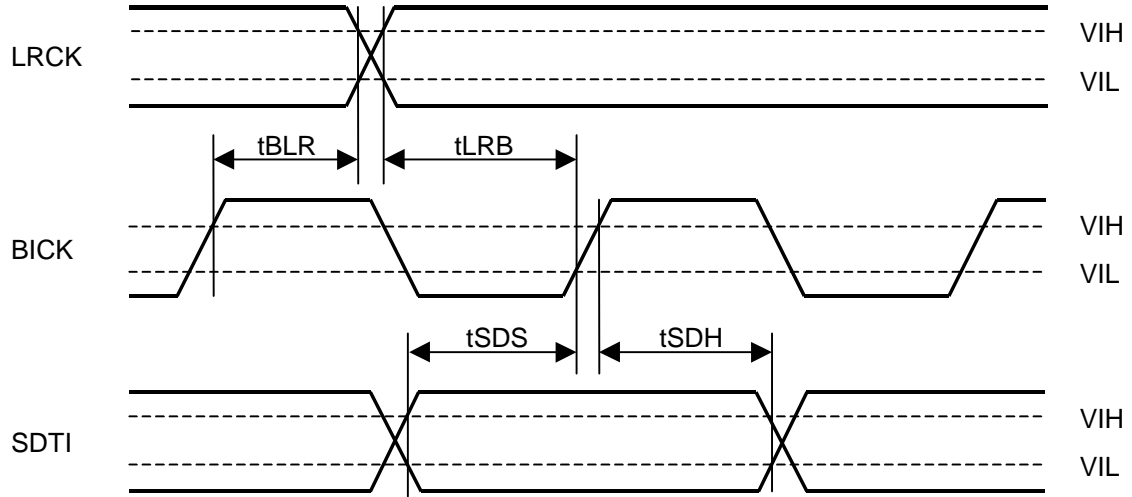

Serial Interface Timing

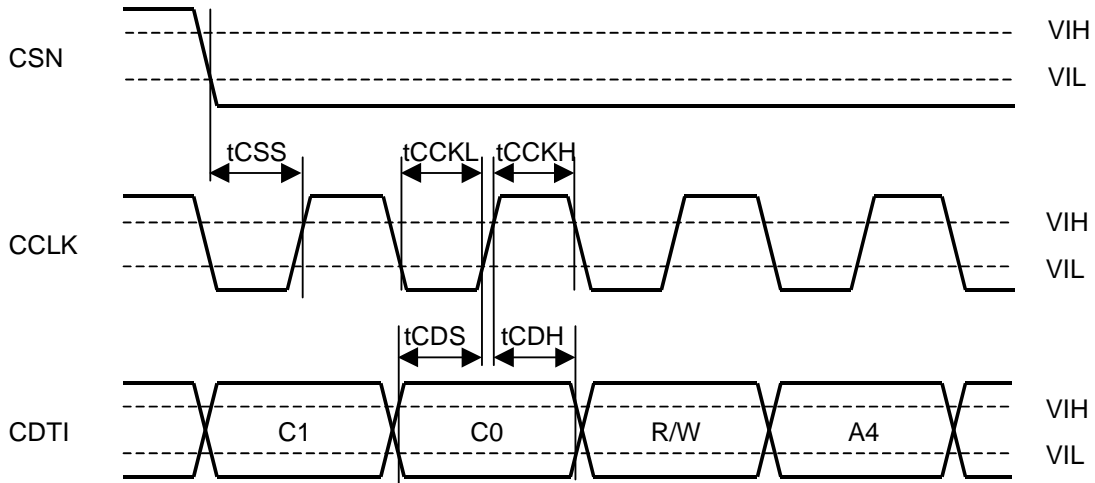

WRITE Command Input Timing

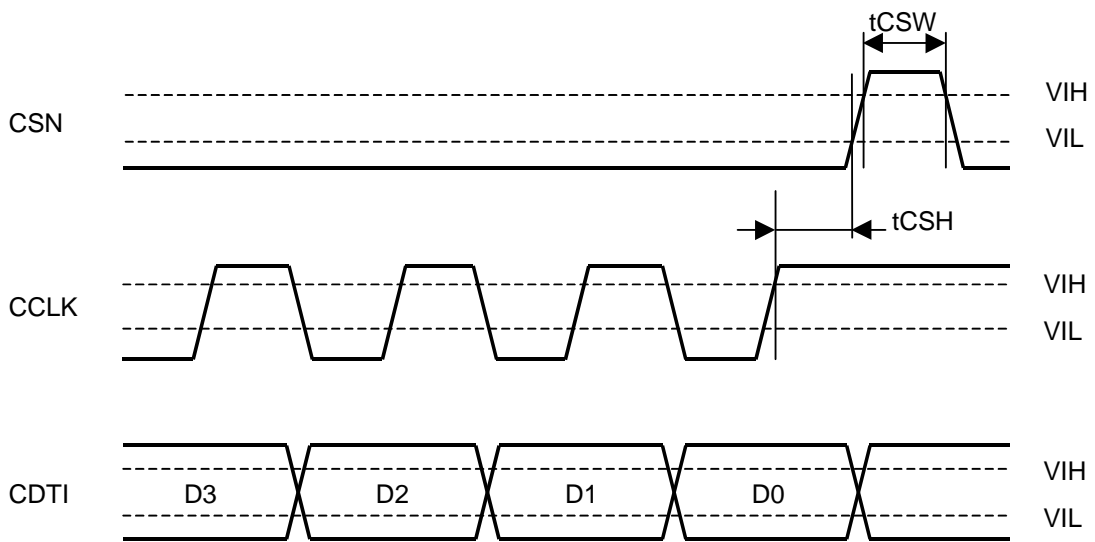

WRITE Data Input Timing

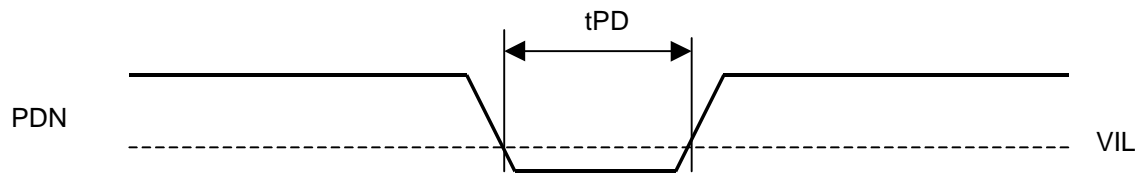

Power-down Timing

| |
|---------------------------|
| OPERATION OVERVIEW |
|---------------------------|

■ System Clock

The external clocks, which are required to operate the AK4385, are MCLK, LRCK and BICK. The master clock (MCLK) should be synchronized with LRCK but the phase is not critical. The MCLK is used to operate the digital interpolation filter and the delta-sigma modulator. There are two methods to set MCLK frequency. In Manual Setting Mode (ACKS = "0": Register 00H), the sampling speed is set by DFS0/1 (Table 1). The frequency of MCLK at each sampling speed is set automatically. (Table 2~4). After exiting reset (PDN = "↑"), the AK4385 is in Auto Setting Mode. In Auto Setting Mode (ACKS = "1": Default), as MCLK frequency is detected automatically (Table 5), and the internal master clock becomes the appropriate frequency (Table 6), it is not necessary to set DFS0/1.

All external clocks (MCLK, BICK and LRCK) should always be present whenever the AK4385 is in the normal operation mode (PDN = "H"). If these clocks are not provided, the AK4385 may draw excess current and may fall into unpredictable operation. This is because the device utilizes dynamic refreshed logic internally. The AK4385 should be reset by PDN = "L" after these clocks are provided. If the external clocks are not present, the AK4385 should be in the power-down mode (PDN = "L"). After exiting reset at power-up etc., the AK4385 is in the power-down mode until MCLK and LRCK are input.

| DFS1 | DFS0 | Sampling Rate (fs) | | Default |
|------|------|--------------------|---------------|---------|
| 0 | 0 | Normal Speed Mode | 8kHz~48kHz | |
| 0 | 1 | Double Speed Mode | 60kHz~96kHz | |
| 1 | 0 | Quad Speed Mode | 120kHz~192kHz | |

Table 1. Sampling Speed (Manual Setting Mode)

| LRCK | MCLK | | | | | BICK |
|---------|------------|------------|------------|------------|------------|-----------|
| fs | 256fs | 384fs | 512fs | 768fs | 1152fs | 64fs |
| 32.0kHz | 8.1920MHz | 12.2880MHz | 16.3840MHz | 24.5760MHz | 36.8640MHz | 2.0480MHz |
| 44.1kHz | 11.2896MHz | 16.9344MHz | 22.5792MHz | 33.8688MHz | N/A | 2.8224MHz |
| 48.0kHz | 12.2880MHz | 18.4320MHz | 24.5760MHz | 36.8640MHz | N/A | 3.0720MHz |

Table 2. System Clock Example (Normal Speed Mode @Manual Setting Mode)

| LRCK | MCLK | | | | BICK |
|---------|------------|------------|------------|------------|-----------|
| fs | 128fs | 192fs | 256fs | 384fs | 64fs |
| 88.2kHz | 11.2896MHz | 16.9344MHz | 22.5792MHz | 33.8688MHz | 5.6448MHz |
| 96.0kHz | 12.2880MHz | 18.4320MHz | 24.5760MHz | 36.8640MHz | 6.1440MHz |

Table 3. System Clock Example (Double Speed Mode @Manual Setting Mode)

| LRCK | MCLK | | BICK |
|----------|------------|------------|------------|
| fs | 128fs | 192fs | 64fs |
| 176.4kHz | 22.5792MHz | 33.8688MHz | 11.2896MHz |
| 192.0kHz | 24.5760MHz | 36.8640MHz | 12.2880MHz |

Table 4. System Clock Example (Quad Speed Mode @Manual Setting Mode)

| MCLK | | Sampling Speed |
|-------|-------|----------------|
| 512fs | 768fs | Normal |
| 256fs | 384fs | Double |
| 128fs | 192fs | Quad |

Table 5. Sampling Speed (Auto Setting Mode: Default)

| LRCK fs | MCLK (MHz) | | | | | | Sampling Speed |
|------------|------------|---------|---------|---------|---------|---------|----------------|
| | 128fs | 192fs | 256fs | 384fs | 512fs | 768fs | |
| 32.0kHz | - | - | - | - | 16.3840 | 24.5760 | Normal |
| 44.1kHz | - | - | - | - | 22.5792 | 33.8688 | |
| 48.0kHz | - | - | - | - | 24.5760 | 36.8640 | |
| 88.2kHz | - | - | 22.5792 | 33.8688 | - | - | Double |
| 96.0kHz | - | - | 24.5760 | 36.8640 | - | - | |
| 176.4kHz | 22.5792 | 33.8688 | - | - | - | - | Quad |
| 192.0kHz | 24.5760 | 36.8640 | - | - | - | - | |

Table 6. System Clock Example (Auto Setting Mode)

■ Audio Serial Interface Format

Data is shifted in via the SDTI pin using BICK and LRCK inputs. The DIF0-2 as shown in Table 7 can select five serial data modes. In all modes the serial data is MSB-first, 2's complement format and is latched on the rising edge of BICK. Mode 2 can be used for 16/20 MSB justified formats by zeroing the unused LSBs.

| Mode | DIF2 | DIF1 | DIF0 | SDTI Format | BICK | Figure |
|------|------|------|------|-----------------------------------|-------|----------|
| 0 | 0 | 0 | 0 | 16bit LSB Justified | ≥32fs | Figure 1 |
| 1 | 0 | 0 | 1 | 20bit LSB Justified | ≥40fs | Figure 2 |
| 2 | 0 | 1 | 0 | 24bit MSB Justified | ≥48fs | Figure 3 |
| 3 | 0 | 1 | 1 | 24bit I ² S Compatible | ≥48fs | Figure 4 |
| 4 | 1 | 0 | 0 | 24bit LSB Justified | ≥48fs | Figure 2 |

Default

Table 7. Audio Data Formats

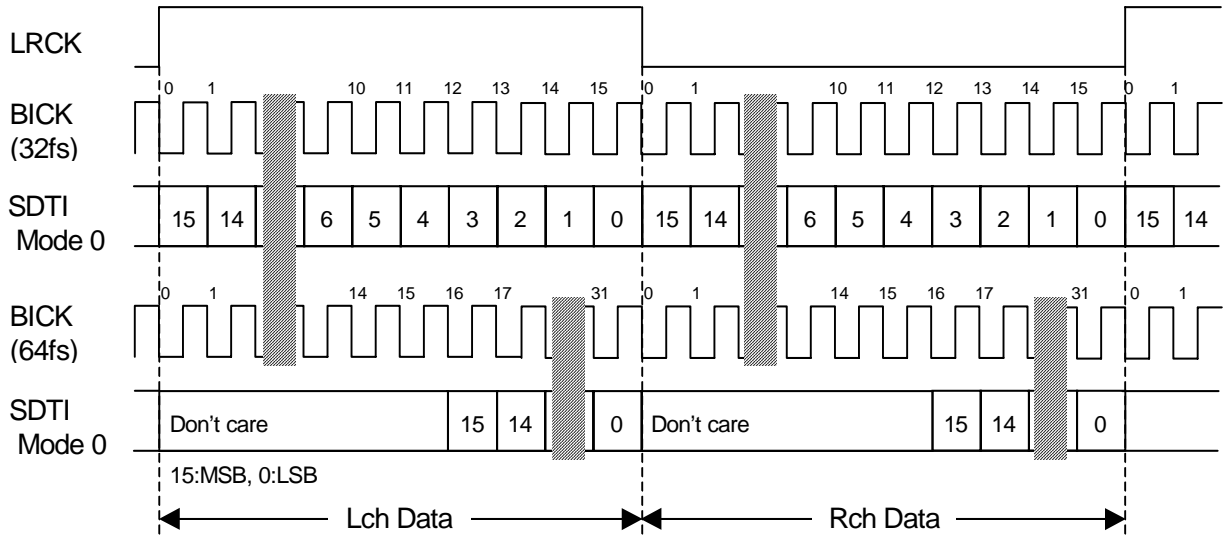

Figure 1. Mode 0 Timing

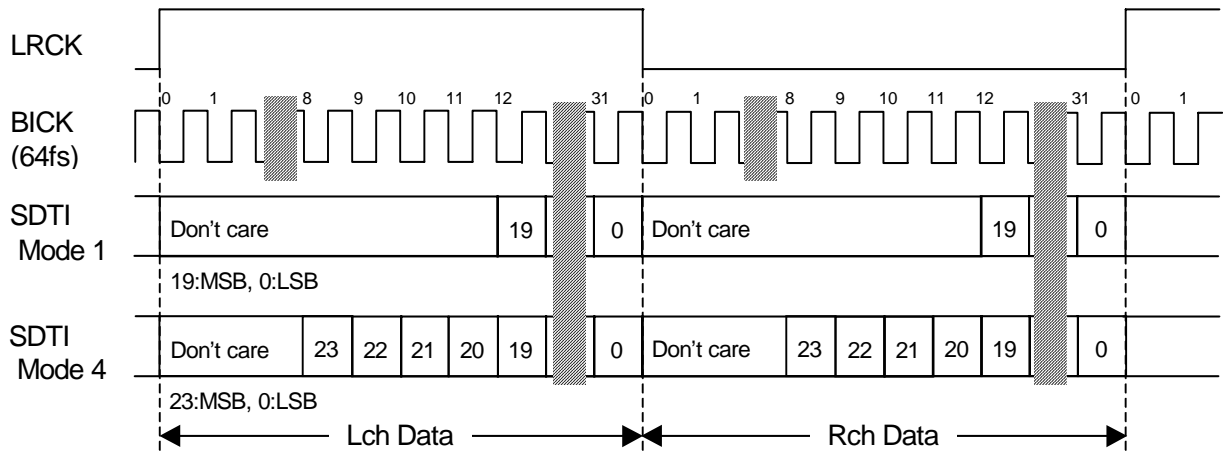

Figure 2. Mode 1,4 Timing

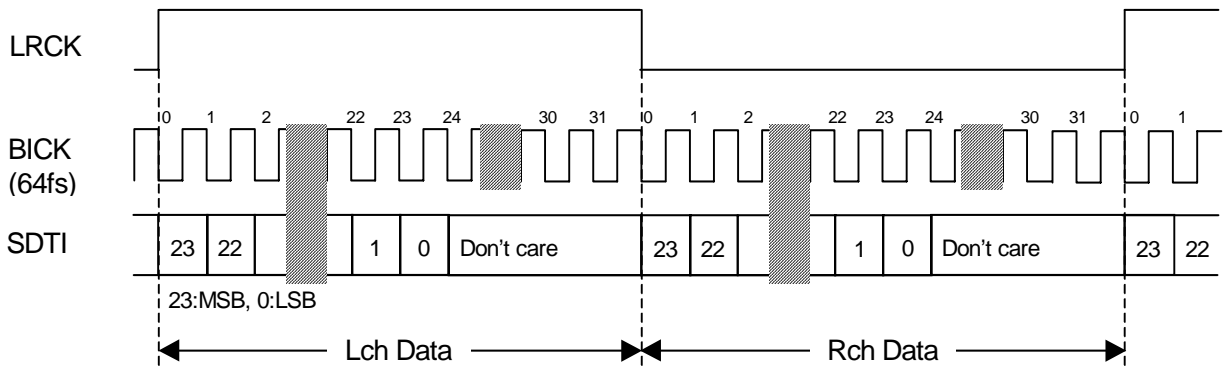

Figure 3. Mode 2 Timing

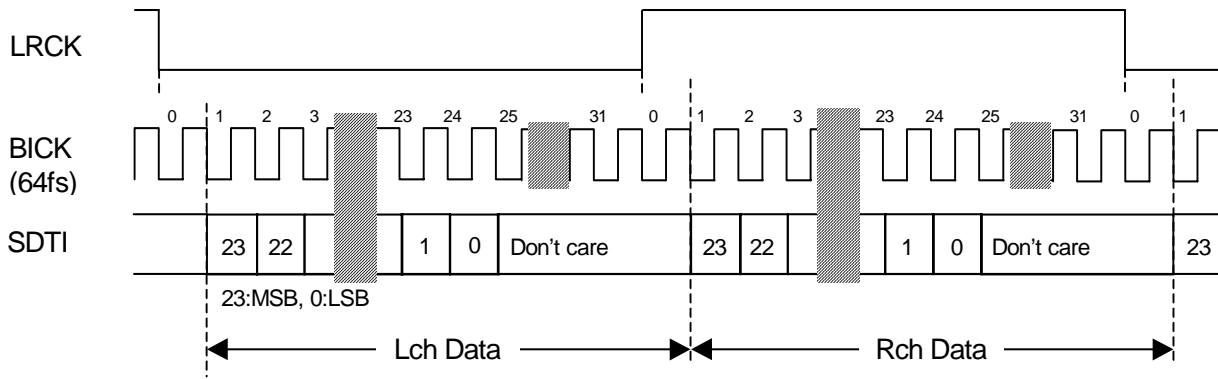

Figure 4. Mode 3 Timing

De-emphasis Filter

A digital de-emphasis filter is available for 32, 44.1 or 48kHz sampling rates ($t_c = 50/15\mu s$) and is enabled or disabled with DEM0 and DEM1. In case of double speed and quad speed mode, the digital de-emphasis filter is always off.

| DEM1 | DEM0 | Mode |
|------|------|---------|
| 0 | 0 | 44.1kHz |
| 0 | 1 | OFF |
| 1 | 0 | 48kHz |
| 1 | 1 | 32kHz |

Default

Table 8. De-emphasis Filter Control (Normal Speed Mode)

Output Volume

The AK4385 includes channel independent digital output volumes (ATT) with 256 levels at linear step including MUTE. These volumes are in front of the DAC and can attenuate the input data from 0dB to -48dB and mute. When changing levels, transitions are executed via soft changes; thus no switching noise occurs during these transitions. The transition time of 1 level and all 256 levels is shown in Table 9.

| Sampling Speed | Transition Time | |
|-------------------|-----------------|----------|
| | 1 Level | 255 to 0 |
| Normal Speed Mode | 4LRCK | 1020LRCK |
| Double Speed Mode | 8LRCK | 2040LRCK |
| Quad Speed Mode | 16LRCK | 4080LRCK |

Table 9. ATT Transition Time

■ System Reset

The AK4385 should be reset once by bringing PDN= "L" upon power-up. The AK4385 is powered up and the internal timing starts clocking by LRCK "↑" after exiting reset and power down state by MCLK. The AK4385 is in the power-down mode until MCLK and LRCK are input.

■ Power-down

The AK4385 is placed in the power-down mode by bringing PDN pin "L" and the analog outputs are floating (Hi-Z). Figure 6 shows an example of the system timing at the power-down and power-up.

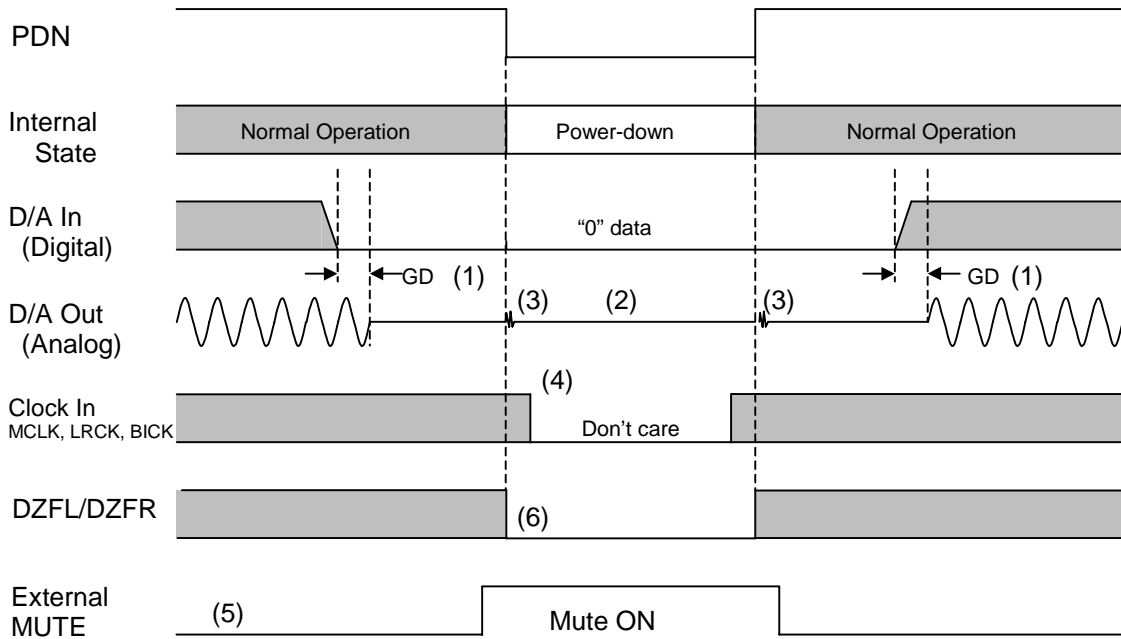

Notes:

- (1) The analog output corresponding to digital input has the group delay (GD).
- (2) Analog outputs are floating (Hi-Z) at the power-down mode.
- (3) Click noise occurs at the edge of PDN signal. This noise is output even if "0" data is input.
- (4) The external clocks (MCLK, BICK and LRCK) can be stopped in the power-down mode (PDN = "L").
- (5) Please mute the analog output externally if the click noise (3) influences system application.
The timing example is shown in this figure.
- (6) DZF pins are "L" in the power-down mode (PDN = "L").

Figure 6. Power-down/up Sequence Example

■ Reset Function

When RSTN=0, DAC is powered down but the internal register values are not initialized. The analog outputs go to VCOM voltage and DZF pin goes to “H”. Figure 7 shows the example of reset by RSTN bit.

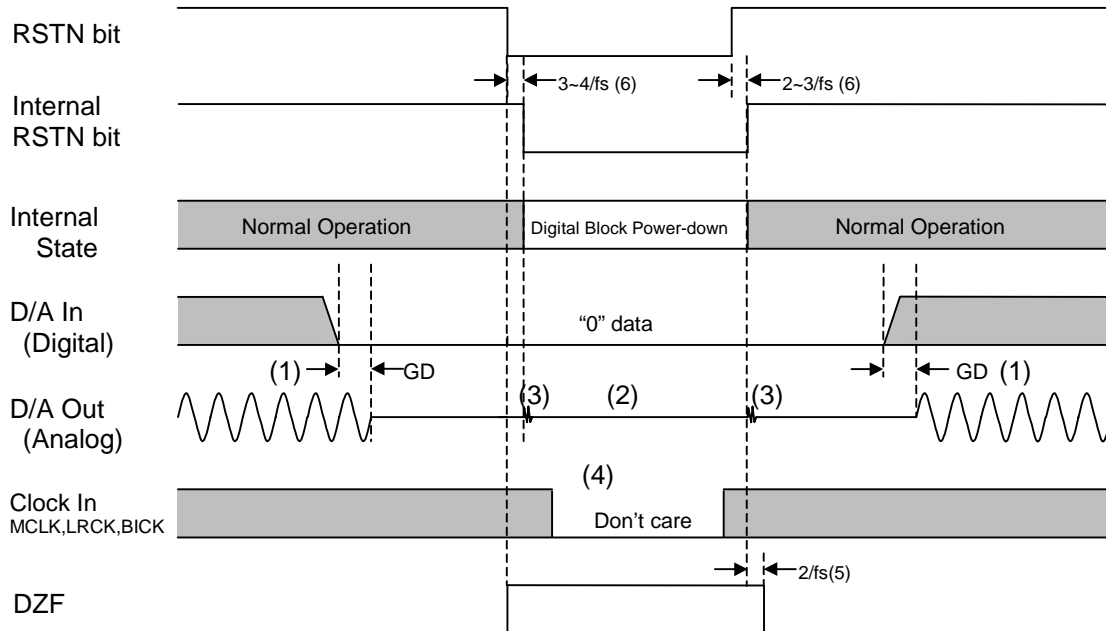

Notes:

- (1) The analog output corresponding to digital input has the group delay (GD).
- (2) Analog outputs go to VCOM voltage ($V_{DD}/2$).
- (3) Click noise occurs at the edges (“↑ ↓”) of the internal timing of RSTN bit. This noise is output even if “0” data is input.
- (4) The external clocks (MCLK, BICK and LRCK) can be stopped in the reset mode ($RSTN = “L”$).
- (5) DZF pins go to “H” when the RSTN bit becomes “0”, and go to “L” at $2/f_s$ after RSTN bit becomes “1”.
- (6) There is a delay, $3\sim 4/f_s$ from RSTN bit “0” to the internal RSTN bit “0”, and $2\sim 3/f_s$ from RSTN bit “1” to the internal RSTN “1”.

Figure 7. Reset Sequence Example

■ Mode Control Interface

Internal registers may be written by 3-wire μ P interface pins, CSN, CCLK and CDTI. The data on this interface consists of Chip Address (2bits, C1/0; fixed to “01”), Read/Write (1bit; fixed to “1”, Write only), Register Address (MSB first, 5bits) and Control Data (MSB first, 8bits). AK4385 latches the data on the rising edge of CCLK, so data should clocked in on the falling edge. The writing of data becomes valid by CSN “ \uparrow ”. The clock speed of CCLK is 5MHz (max).

PDN = “L” resets the registers to their default values. The internal timing circuit is reset by RSTN bit, but the registers are not initialized.

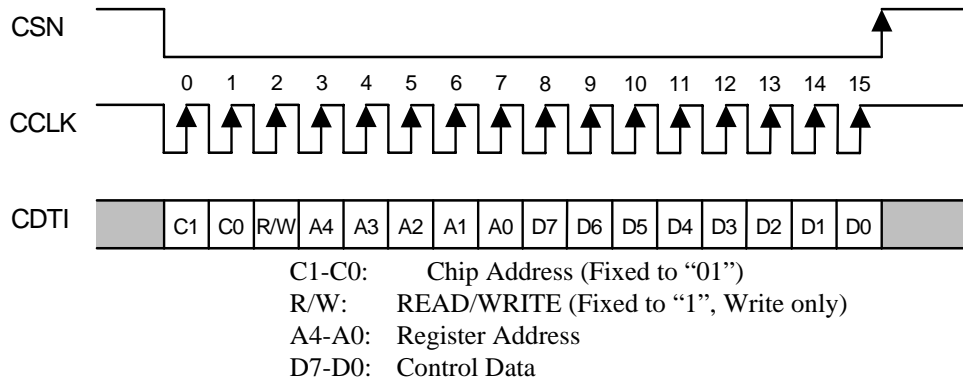

Figure 8. Control I/F Timing

*AK4385 does not support the read command and chip address. C1/0 and R/W are fixed to “011”

*When the AK4385 is in the power down mode (PDN = “L”) or the MCLK is not provided, writing into the control register is inhibited.

■ Register Map

| Addr | Register Name | D7 | D6 | D5 | D4 | D3 | D2 | D1 | D0 |
|------|---------------|------|------|------|------|------|------|------|-------|
| 00H | Control 1 | ACKS | 0 | 0 | DIF2 | DIF1 | DIF0 | PW | RSTN |
| 01H | Control 2 | DZFE | DZFM | SLOW | DFS1 | DFS0 | DEM1 | DEM0 | SMUTE |
| 02H | Control 3 | 0 | 0 | 0 | 0 | 0 | DZFB | 0 | 0 |
| 03H | Lch ATT | ATT7 | ATT6 | ATT5 | ATT4 | ATT3 | ATT2 | ATT1 | ATT0 |
| 04H | Rch ATT | ATT7 | ATT6 | ATT5 | ATT4 | ATT3 | ATT2 | ATT1 | ATT0 |

Notes:

For addresses from 05H to 1FH, data must not be written.

When PDN pin goes “L”, the registers are initialized to their default values.

When RSTN bit goes “0”, the only internal timing is reset and the registers are not initialized to their default values.

All data can be written to the register even if PW or RSTN bit is “0”.

■ Register Definitions

| Addr | Register Name | D7 | D6 | D5 | D4 | D3 | D2 | D1 | D0 |
|------|---------------|------|----|----|------|------|------|----|------|
| 00H | Control 1 | ACKS | 0 | 0 | DIF2 | DIF1 | DIF0 | PW | RSTN |
| | default | 1 | 0 | 0 | 0 | 1 | 0 | 1 | 1 |

RSTN: Internal timing reset control

0: Reset. All registers are not initialized.

1: Normal Operation

When MCLK frequency or DFS changes, the click noise can be reduced by RSTN bit.

PW: Power down control

0: Power down. All registers are not initialized.

1: Normal Operation

DIF2-0: Audio data interface formats (see Table 7)

Initial: "010", Mode 2

ACKS: Master Clock Frequency Auto Setting Mode Enable

0: Disable, Manual Setting Mode

1: Enable, Auto Setting Mode

Master clock frequency is detected automatically at ACKS bit "1". In this case, the setting of DFS1-0 are ignored. When this bit is "0", DFS1-0 set the sampling speed mode.

| Addr | Register Name | D7 | D6 | D5 | D4 | D3 | D2 | D1 | D0 |
|------|---------------|------|------|------|------|------|------|------|-------|
| 01H | Control 2 | DZFE | DZFM | SLOW | DFS1 | DFS0 | DEM1 | DEM0 | SMUTE |
| | default | 0 | 0 | 0 | 0 | 0 | 0 | 1 | 0 |

SMUTE: Soft Mute Enable

0: Normal operation

1: DAC outputs soft-muted

DEM1-0: De-emphasis Response (see Table 8)

Initial: "01", OFF

DFS1-0: Sampling speed control

00: Normal speed

01: Double speed

10: Quad speed

When changing between Normal/Double Speed Mode and Quad Speed Mode, some click noise occurs.

SLOW: Slow Roll-off Filter Enable

0: Sharp Roll-off Filter

1: Slow Roll-off Filter

DZFE: Data Zero Detect Enable

0: Disable

1: Enable

Zero detect function can be disabled by DZFE bit "0". In this case, the DZF pins of both channels are always "L".

DZFM: Data Zero Detect Mode

- 0: Channel Separated Mode
- 1: Channel ANDED Mode

If the DZFM bit is set to “1”, the DZF pins of both channels go to “H” only when the input data at both channels are continuously zeros for 8192 LRCK cycles.

| Addr | Register Name | D7 | D6 | D5 | D4 | D3 | D2 | D1 | D0 |
|------|---------------|----|----|----|----|----|------|----|----|
| 02H | Control 3 | 0 | 0 | 0 | 0 | 0 | DZFB | 0 | 0 |
| | default | 0 | 0 | 0 | 0 | 0 | 0 | 0 | 0 |

DZFB: Inverting Enable of DZF

- 0: DZF goes “H” at Zero Detection
- 1: DZF goes “L” at Zero Detection

| Addr | Register Name | D7 | D6 | D5 | D4 | D3 | D2 | D1 | D0 |
|------|---------------|------|------|------|------|------|------|------|------|
| 03H | Lch ATT | ATT7 | ATT6 | ATT5 | ATT4 | ATT3 | ATT2 | ATT1 | ATT0 |
| 04H | Rch ATT | ATT7 | ATT6 | ATT5 | ATT4 | ATT3 | ATT2 | ATT1 | ATT0 |
| | default | 1 | 1 | 1 | 1 | 1 | 1 | 1 | 1 |

$$ATT = 20 \log_{10} (ATT_DATA / 255) \text{ [dB]}$$

00H: Mute

SYSTEM DESIGN

Figure 9 shows the system connection diagram. An evaluation board (AKD4385) is available in order to allow an easy study on the layout of a surrounding circuit.

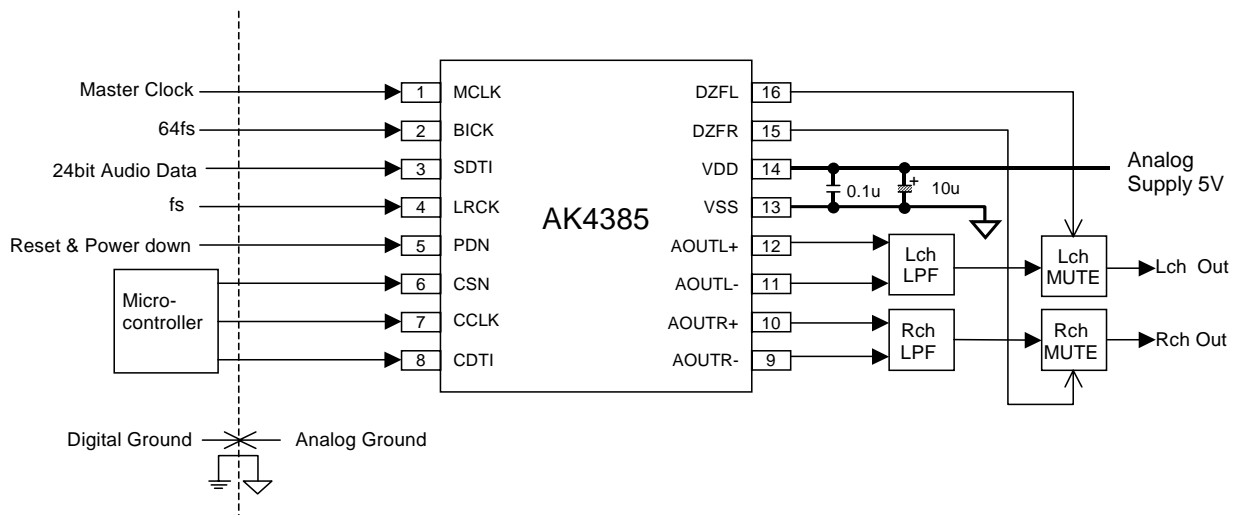

Figure 9. Typical Connection Diagram

Notes:

- LRCK = fs, BICK = 64fs.
- When AOUT drives some capacitive load, some resistor should be added in series between AOUT and capacitive load.
- All input pins should not be left floating.

1. Grounding and Power Supply Decoupling

VDD and VSS are supplied from analog supply and should be separated from system digital supply. Decoupling capacitor, especially 0.1μF ceramic capacitor for high frequency should be placed as near to VDD as possible. The differential Voltage between VDD and VSS pins set the analog output range.

2. Analog Outputs

The analog outputs are full-differential outputs and 0.55 x VDD Vpp (typ) centered around the internal common voltage (about AVDD/2). The differential outputs are summed externally, $V_{AOUT}=(AOUT+)-(AOUT-)$ between AOUT+ and AOUT-. If the summing gain is 1, the output range is 5.5Vpp (typ @VREFH=5V). The bias voltage of the external summing circuit is supplied externally. The input data format is 2's complement. The output voltage (V_{AOUT}) is a positive full scale for 7FFFFFFF (@24bit) and a negative full scale for 800000H (@24bit). The ideal V_{AOUT} is 0V for 000000H (@24bit).

The internal switched-capacitor filter and external low pass filter attenuate the noise generated by the delta-sigma modulator beyond the audio passband. DC offset on AOUT+/- is eliminated without AC coupling since the analog outputs are differential. Figure 10 and 11 show the example of external op-amp circuit summing the differential outputs.

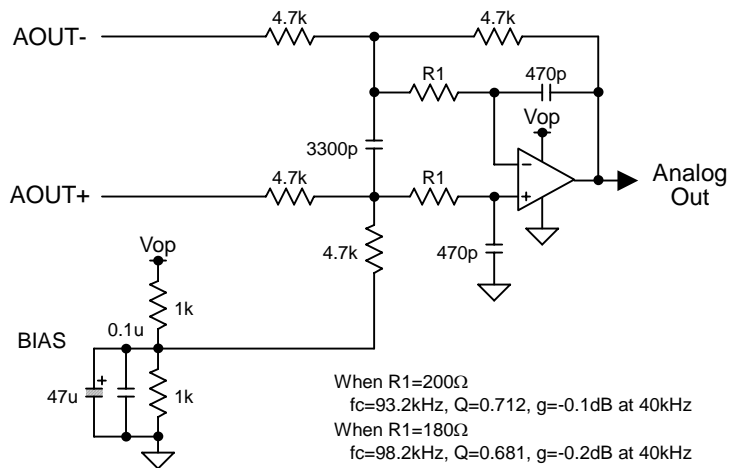

Figure 10. External 2nd order LPF Circuit Example (using op-amp with single power supply)

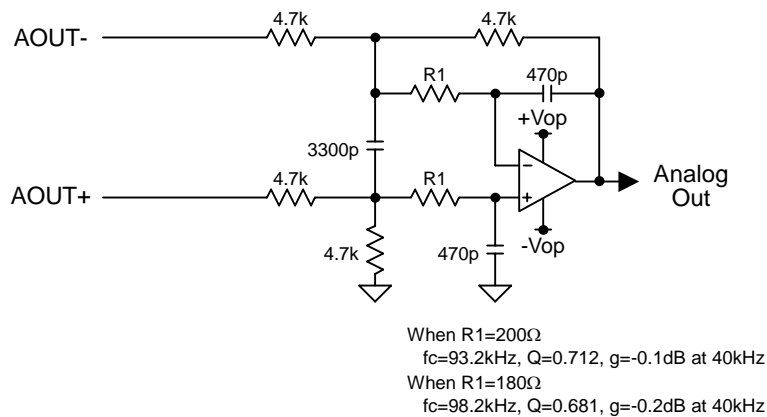
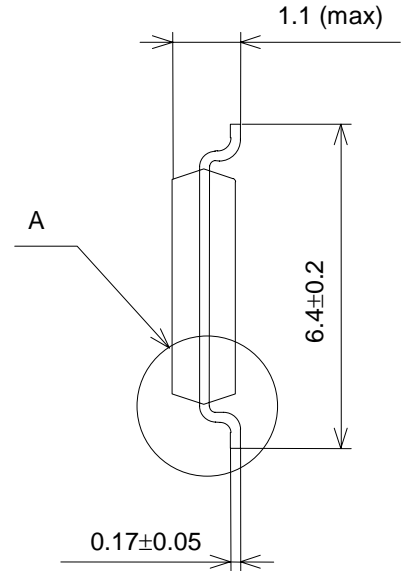
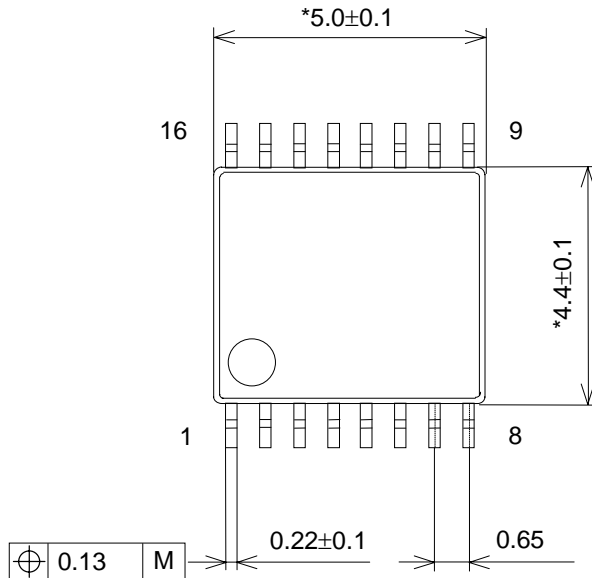

Figure 11. External 2nd order LPF Circuit Example (using op-amp with dual power supplies)

PACKAGE

16pin TSSOP (Unit: mm)



Detail A

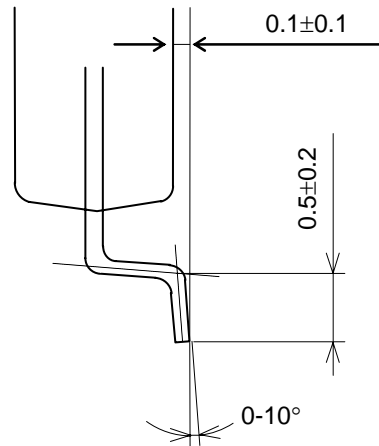
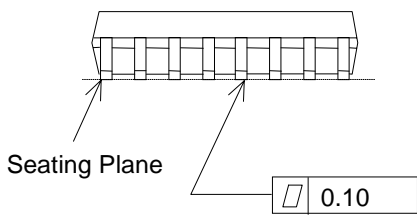

NOTE: Dimension "*" does not include mold flash.

■ Package & Lead frame material

- Package molding compound: Epoxy
- Lead frame material: Cu
- Lead frame surface treatment: Solder(Pb free) plate

MARKING (AK4385VT)

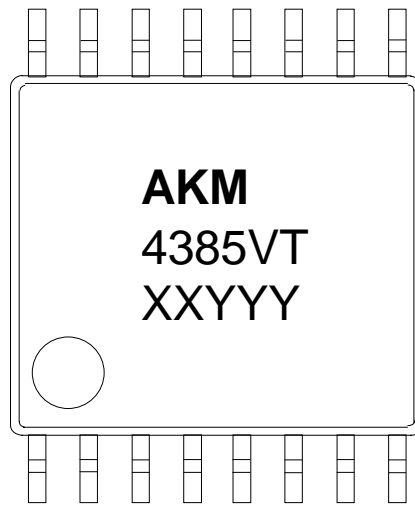

- 1) Pin #1 indication
- 2) Date Code : XXYYY (5 digits)
XX: Lot#
YYY: Date Code
- 3) Marketing Code : 4385VT
- 4) Asahi Kasei Logo

MARKING (AK4385ET)

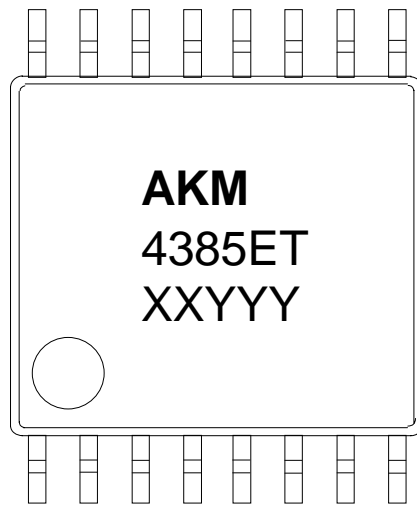

- 5) Pin #1 indication
- 6) Date Code : XXYYY (5 digits)
 - XX: Lot#
 - YYY: Date Code
- 7) Marketing Code : 4385ET
- 8) Asahi Kasei Logo

| |
|-------------------------|
| REVISION HISTORY |
|-------------------------|

| Date (YY/MM/DD) | Revision | Reason | Page | Contents |
|-----------------|----------|-------------------------|------|---|
| 03/07/02 | 00 | First Edition | | |
| 06/01/11 | 01 | Spec Addition | 2 | Ordering Guide AK4385ET was added. |
| | | | 22 | MARKING AK4385ET was added. |
| 10/09/28 | 02 | Specification Change | 20 | PACKAGE The package dimension was changed. |

IMPORTANT NOTICE

- These products and their specifications are subject to change without notice.
When you consider any use or application of these products, please make inquiries the sales office of Asahi Kasei Microdevices Corporation (AKM) or authorized distributors as to current status of the products.
- Descriptions of external circuits, application circuits, software and other related information contained in this document are provided only to illustrate the operation and application examples of the semiconductor products. You are fully responsible for the incorporation of these external circuits, application circuits, software and other related information in the design of your equipments. AKM assumes no responsibility for any losses incurred by you or third parties arising from the use of these information herein. AKM assumes no liability for infringement of any patent, intellectual property, or other rights in the application or use of such information contained herein.
- Any export of these products, or devices or systems containing them, may require an export license or other official approval under the law and regulations of the country of export pertaining to customs and tariffs, currency exchange, or strategic materials.
- AKM products are neither intended nor authorized for use as critical components_{Note1} in any safety, life support, or other hazard related device or system_{Note2}, and AKM assumes no responsibility for such use, except for the use approved with the express written consent by Representative Director of AKM. As used here:
 - Note1) A critical component is one whose failure to function or perform may reasonably be expected to result, whether directly or indirectly, in the loss of the safety or effectiveness of the device or system containing it, and which must therefore meet very high standards of performance and reliability.
 - Note2) A hazard related device or system is one designed or intended for life support or maintenance of safety or for applications in medicine, aerospace, nuclear energy, or other fields, in which its failure to function or perform may reasonably be expected to result in loss of life or in significant injury or damage to person or property.
- It is the responsibility of the buyer or distributor of AKM products, who distributes, disposes of, or otherwise places the product with a third party, to notify such third party in advance of the above content and conditions, and the buyer or distributor agrees to assume any and all responsibility and liability for and hold AKM harmless from any and all claims arising from the use of said product in the absence of such notification.

Looking for pricing, stock, or lifecycle information?

Click below to explore more details on WIN SOURCE:

- ⊖ [View AK4385ET on WIN SOURCE](#)
- ⊖ [AKM Semiconductor Inc. Information](#)

Optimize Your Supply Chain with WIN SOURCE Solutions

- ✓ Global Sourcing Solution
- ✓ Obsolete Management
- ✓ Cost Control Management
- ✓ Shortage Management
- ✓ Alternative Solution
- ✓ Excess Inventory Management