



**THE DATASHEET OF  
TPS43330AQDAPRQ1**



# TPS43330A-Q1 Low $I_Q$ , Single-Boost Dual Synchronous Buck Controller

## 1 Features

- Qualified for Automotive Applications
- AEC-Q100 Qualified With the Following Results:
  - Device Temperature Grade 1:  $-40^{\circ}\text{C}$  to  $+125^{\circ}\text{C}$  Ambient Operating Temperature
  - Device HBM ESD Classification Level H2
  - Device CDM ESD Classification Level C2
- Two Synchronous Buck Controllers
- One Pre-Boost Controller
- Input Range up to 40 V, (Transients up to 60 V), Operation Down to 2 V When Boost is Enabled
- Low-Power-Mode  $I_Q$ : 30  $\mu\text{A}$  (One Buck On), 35  $\mu\text{A}$  (Two Bucks On)
- Low Shutdown Current:  $I_{sh} < 4 \mu\text{A}$
- Buck Output Range 0.9 to 11 V
- Boost Output Selectable: 7 V, 8.85 V, or 10 V
- Programmable Frequency and External Synchronization Range 150 to 600 kHz
- Separate Enable Inputs (ENA, ENB, ENC)
- Selectable Forced Continuous Mode or Automatic Low-Power Mode at Light Loads
- Sense Resistor or Inductor DCR Sensing for Buck Controllers
- Out-of-Phase Switching Between Buck Channels
- Peak Gate-Drive Current: 1.5 A
- Thermally Enhanced 38-Pin HTSSOP (DAP) PowerPAD™ Package

## 2 Applications

- Automotive Start-Stop, Infotainment, Navigation Instrument Cluster Systems
- Industrial and Automotive Multi-Rail DC Power Distribution Systems and Electronic Control Units

## 3 Description

The TPS43330A-Q1 device includes two current-mode synchronous-buck controllers and a voltage-mode boost controller. The device is ideally suited as a pre-regulator stage with low  $I_Q$  requirements and for applications that must survive supply drops due to cranking events. The integrated boost controller allows the device to operate down to 2 V at the input without seeing a drop on the buck regulator output stages. At light loads, the buck controllers enable to operate automatically in low-power mode, consuming just 30  $\mu\text{A}$  of quiescent current.

The buck controllers have independent soft-start capability and power-good indicators. Current foldback in the buck controllers and cycle-by-cycle current limitation in the boost controller provide external MOSFET protection. The switching frequency is programmable over 150 to 600 kHz or is synchronized to an external clock in the same range.

### Device Information<sup>(1)</sup>

PART NUMBER	PACKAGE	BODY SIZE (NOM)
TPS43330A-Q1	HTSSOP (38)	12.50 mm x 6.20 mm

(1) For all available packages, see the orderable addendum at the end of the data sheet.

### Typical Application Diagram

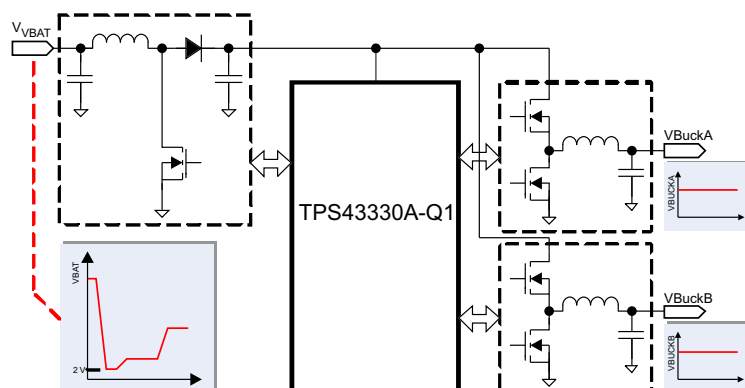

Copyright © 2016, Texas Instruments Incorporated



## Table of Contents

<b>1 Features</b> ..... 1 <b>2 Applications</b> ..... 1 <b>3 Description</b> ..... 1 <b>4 Revision History</b> ..... 2 <b>5 Pin Configuration and Functions</b> ..... 3 <b>6 Specifications</b> ..... 6 6.1 Absolute Maximum Ratings ..... 6 6.2 ESD Ratings..... 6 6.3 Recommended Operating Conditions ..... 7 6.4 Thermal Information ..... 7 6.5 DC Electrical Characteristics ..... 7 6.6 Switching Characteristics ..... 11 6.7 Typical Characteristics ..... 12 <b>7 Detailed Description</b> ..... 15 7.1 Overview ..... 15 7.2 Functional Block Diagram ..... 16 7.3 Feature Description ..... 17 7.4 Device Functional Modes..... 21	<b>8 Application and Implementation</b> ..... 25 8.1 Application Information..... 25 8.2 Typical Application ..... 25 8.3 System Examples ..... 35 <b>9 Power Supply Recommendations</b> ..... 37 <b>10 Layout</b> ..... 37 10.1 Layout Guidelines ..... 37 10.2 Layout Example ..... 38 10.3 Power Dissipation Derating Profile, 38-Pin HTTSOP PowerPAD™ Package ..... 39 <b>11 Device and Documentation Support</b> ..... 40 11.1 Receiving Notification of Documentation Updates 40 11.2 Community Resources ..... 40 11.3 Trademarks ..... 40 11.4 Electrostatic Discharge Caution ..... 40 11.5 Glossary ..... 40 <b>12 Mechanical, Packaging, and Orderable        Information</b> ..... 40
---	---

## 4 Revision History

NOTE: Page numbers for previous revisions may differ from page numbers in the current version.

Changes from Revision A (September 2013) to Revision B	Page
• Added <i>ESD Ratings</i> table, <i>Feature Description</i> section, <i>Device Functional Modes</i> , <i>Application and Implementation</i> section, <i>Power Supply Recommendations</i> section, <i>Layout</i> section, <i>Device and Documentation Support</i> section, and <i>Mechanical, Packaging, and Orderable Information</i> section. ....	1
• Removed <i>Package and Ordering Information</i> section, see the POA at the end of the data sheet.....	1
• Removed <i>Simplified Application Schematic, Example 2</i> from the data sheet.....	35
• Renamed <i>Simplified Application Schematic, Example 3</i> to <i>Simplified Application Schematic, Example 2</i> .....	36
• Changed L1 value from 4 $\mu$ H to 3.9 $\mu$ H under the <i>Application Example 2 – Component Proposals</i> table .....	36

Changes from Original (August 2013) to Revision A	Page
• Changed document status from <i>Product Preview</i> to <i>Production Data</i> .....	1

## 5 Pin Configuration and Functions

**DAP Package  
38-Pin HTSSOP  
Top View**

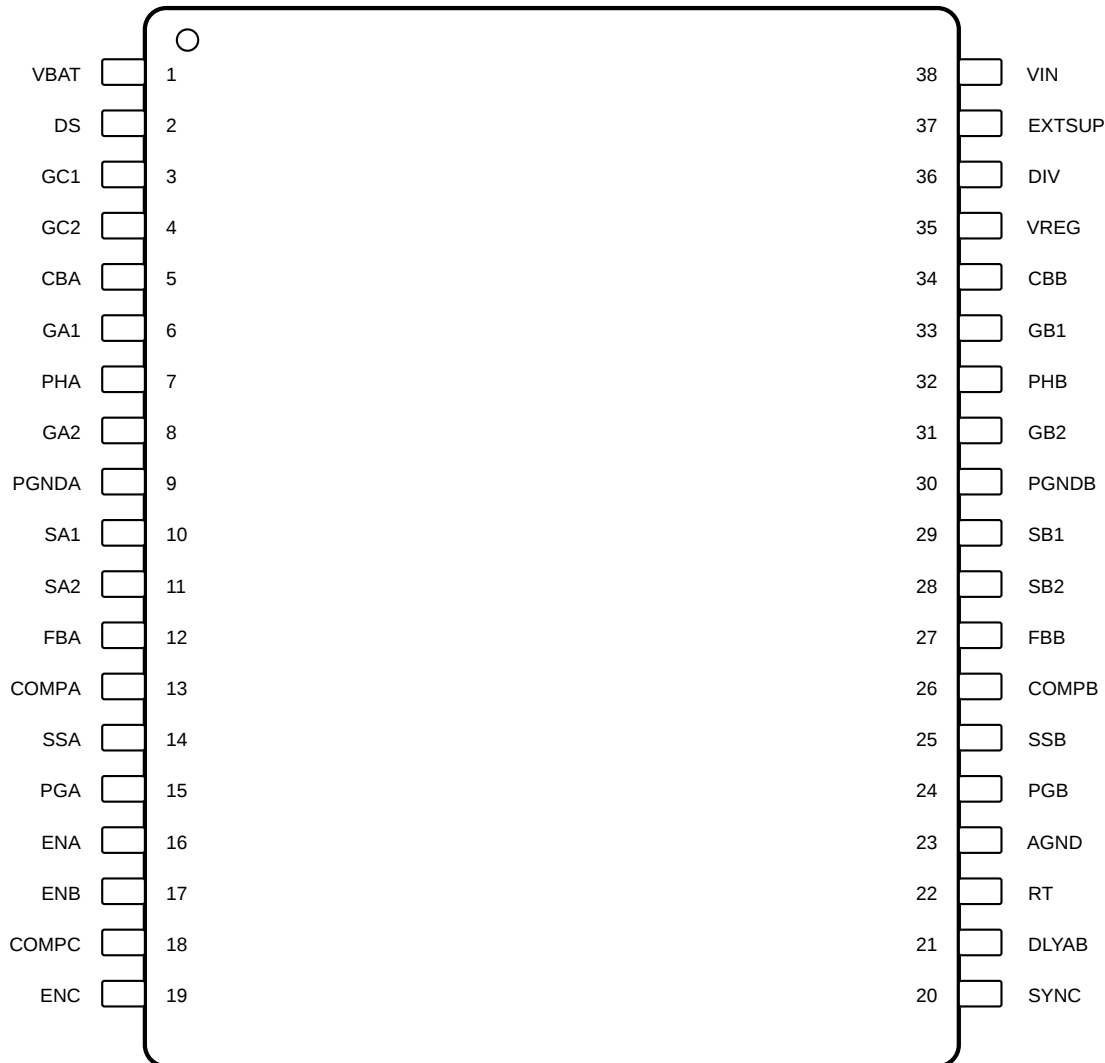

**Pin Functions**

PIN		I/O	DESCRIPTION
NAME	NO.		
AGND	23	O	Analog ground reference
CBA	5	I	A capacitor on this pin acts as the voltage supply for the high-side N-channel MOSFET gate-drive circuitry in buck controller BuckA. When the buck is in a dropout condition, the device automatically reduces the duty cycle of the high-side MOSFET to approximately 95% on every fourth cycle to allow the capacitor to recharge.
CBB	34	I	A capacitor on this pin acts as the voltage supply for the high-side N-channel MOSFET gate-drive circuitry in buck controller BuckB. When the buck is in a dropout condition, the device automatically reduces the duty cycle of the high-side MOSFET to approximately 95% on every fourth cycle to allow the capacitor to recharge.
COMPA	13	O	Error amplifier output of BuckA and compensation node for voltage-loop stability. The voltage at this node sets the target for the peak current through the inductor of BuckA. Clamping this voltage on the upper and lower ends provides current-limit protection for the external MOSFETs.
COMPB	26	O	Error amplifier output of BuckB and compensation node for voltage-loop stability. The voltage at this node sets the target for the peak current through the inductor of BuckB. Clamping this voltage on the upper and lower ends provides current-limit protection for the external MOSFETs.

**Pin Functions (continued)**

PIN		I/O	DESCRIPTION
NAME	NO.		
COMPC	18	O	Error-amplifier output and loop-compensation node of the boost regulator
DIV	36	I	The status of this pin defines the output voltage of the boost regulator. A high input regulates the boost converter at 8.85 V, a low input sets the value at 7 V, and a floating pin sets 10 V. <b>NOTE:</b> DIV = high and ENC = high inhibits low-power mode on the bucks.
DLYAB	21	O	The capacitor at the DLYAB pin sets the power-good delay interval used to de-glitch the outputs of the power-good comparators. Leaving this pin open sets the power-good delay to an internal default value of 20 $\mu$ s typical.
DS	2	I	This input monitors the voltage on the external boost-converter low-side MOSFET for overcurrent protection. An alternative connection for better noise immunity is to a sense resistor between the source of the low-side MOSFET and ground via a filter network.
ENA	16	I	Enable input for BuckA (active-high with an internal pullup current source). An input voltage higher than 1.7 V enables the controller, whereas an input voltage lower than 0.7 V disables the controller. When both ENA and ENB are low, the device shuts down and consumes less than 4 $\mu$ A of current. <b>NOTE:</b> DIV = high and ENC = high inhibits low-power mode on the bucks.
ENB	17	I	Enable input for BuckB (active-high with an internal pullup current source). An input voltage higher than 1.7 V enables the controller, whereas an input voltage lower than 0.7 V disables the controller. When both ENA and ENB are low, the device shuts down and consumes less than 4 $\mu$ A of current. <b>NOTE:</b> DIV = high and ENC = high inhibits low-power mode on the bucks.
ENC	19	I	This input enables and disables the boost regulator. An input voltage higher than 1.7 V enables the controller. Voltages lower than 0.7 V disable the controller. Because this pin provides an internal pulldown resistor (500 k $\Omega$ ), enabling the boost function requires pulling it high. When enabled, the controller starts switching as soon as $V_{BAT}$ falls below the boost threshold, depending upon the programmed output voltage.
EXTSUP	37	I	One can use EXTSUP to supply the VREG regulator from one of the TPS43330A-Q1 buck regulator rails to reduce power dissipation in cases where there is an expectation of high $V_{IN}$ . If EXTSUP is unused, leave the pin open without a capacitor installed.
FBA	12	I	Feedback voltage pin for BuckA. The buck controller regulates the feedback voltage to the internal reference of 0.8 V. A suitable resistor divider network between the buck output and the feedback pin sets the desired output voltage.
FBB	27	I	Feedback voltage pin for BuckB. The buck controller regulates the feedback voltage to the internal reference of 0.8 V. A suitable resistor-divider network between the buck output and the feedback pin sets the desired output voltage.
GA1	6	O	This output drives the external high-side N-channel MOSFET for buck regulator BuckA. The output provides high peak currents to drive capacitive loads. The gate-drive reference is to a floating ground provided by PHA that has a voltage swing provided by CBA.
GA2	8	O	This output drives the external low-side N-channel MOSFET for buck regulator BuckA. The output provides high peak currents to drive capacitive loads. VREG provides the voltage swing on this pin.
GB1	33	O	This output drives the external high-side N-channel MOSFET for buck regulator BuckB. The output provides high peak currents to drive capacitive loads. The gate-drive reference is to a floating ground provided by PHB that has a voltage swing provided by CBB.
GB2	31	O	This output drives the external low-side N-channel MOSFET for buck regulator BuckB. The output provides high peak currents to drive capacitive loads. VREG provides the voltage swing on this pin.
GC1	3	O	This output drives an external low-side N-channel MOSFET for the boost regulator. This output provides high peak currents to drive capacitive loads. VREG provides the voltage swing on this pin.
GC2	4	O	This pin makes a floating output drive available to control the external P-channel MOSFET. This MOSFET bypasses the boost rectifier diode or a reverse-protection diode when the boost status is non-switching or disabled, and thus reduce power losses.
PGA	15	O	Open-drain power-good indicator pin for BuckA. An internal power-good comparator monitors the voltage at the feedback pin and pulls this output low when the output voltage falls below 93% of the set value, or if either $V_{IN}$ or $V_{BAT}$ drops below the respective undervoltage threshold.
PGB	24	O	Open-drain power-good indicator pin for BuckB. An internal power-good comparator monitors the voltage at the feedback pin and pulls this output low when the output voltage falls below 93% of the set value, or if either $V_{IN}$ or $V_{BAT}$ drops below the respective undervoltage threshold.
PGNDA	9	GND	Power-ground connection to the source of the low-side N-channel MOSFETs of BuckA
PGNDB	30	GND	Power-ground connection to the source of the low-side N-channel MOSFETs of BuckB
PHA	7	O	Switching terminal of buck regulator BuckA, providing a floating ground reference for the high-side MOSFET gate-driver circuitry. PHA senses current reversal in the inductor when discontinuous-mode operation is desired.
PHB	32	O	Switching terminal of buck regulator BuckB, providing a floating ground reference for the high-side MOSFET gate-driver circuitry. PHB senses current reversal in the inductor when discontinuous-mode operation is desired.

**Pin Functions (continued)**

PIN		I/O	DESCRIPTION
NAME	NO.		
RT	22	O	Connecting a resistor to ground on this pin sets the operational switching frequency of the buck and boost controllers. A short circuit to ground on this pin defaults operation to 400 kHz for the buck controllers and 200 kHz for the boost controller.
SA1	10	I	High-impedance differential-voltage inputs from the current-sense element (sense resistor or inductor DCR) for BuckA. Choose the current-sense element to set the maximum current through the inductor based on the current-limit threshold (subject to tolerances) and considering the typical characteristics across duty cycle and $V_{IN}$ . (SA1 positive node, SA2 negative node).
SA2	11	I	
SB1	29	I	High-impedance differential voltage inputs from the current-sense element (sense resistor or inductor DCR) for BuckB. Choose the current-sense element to set the maximum current through the inductor based on the current-limit threshold (subject to tolerances) and considering the typical characteristics across duty cycle and $V_{IN}$ . (SB1 positive node, SB2 negative node).
SB2	28	I	
SSA	14	O	Soft-start or tracking input for buck controller BuckA. The buck controller regulates the FBA voltage to the lower of 0.8 V or the SSA pin voltage. An internal pullup current source of 50 $\mu$ A is present at the pin, and an appropriate capacitor connected here sets the soft-start ramp interval. Alternatively, a resistor divider connected to another supply provides a tracking input to this pin.
SSB	25	O	Soft-start or tracking input for buck controller BuckB. The buck controller regulates the FBB voltage to the lower of 0.8 V or the SSB pin voltage. An internal pullup current source of 50 $\mu$ A is present at the pin, and an appropriate capacitor connected here sets the soft-start ramp interval. Alternatively, a resistor divider connected to another supply provides a tracking input to this pin.
SYNC	20	I	If an external clock is present on this pin, the device detects it and the internal PLL locks onto the external clock, overriding the internal oscillator frequency. The device synchronizes frequencies from 150 to 600 kHz. A high-logic level on this pin ensures forced continuous-mode operation of the buck controllers and inhibits transition to low-power mode. An open or low allows discontinuous-mode operation and entry into low-power mode at light loads.
VBAT	1	PWR	Battery input sense for the boost controller. If, with the boost controller enabled, the voltage at VBAT falls below the boost threshold, the device activates the boost controller and regulates the voltage at VIN to the programmed boost output voltage.
VIN	38	PWR	Main Input pin. VIN is the buck-controller input pin as well as the output of the boost regulator. Additionally, VIN powers the internal control circuits of the device.
VREG	35	O	The device requires an external capacitor on this pin to provide a regulated supply for the gate drivers of the buck and boost controllers. TI recommends capacitance on the order of 4.7 $\mu$ F. The regulator obtains power from either VIN or EXTSUP. This pin has current-limit protection; do not use it to drive any other loads.

## 6 Specifications

### 6.1 Absolute Maximum Ratings<sup>(1)</sup>

		MIN	MAX	UNIT
Voltage	Input voltage: VIN, VBAT	-0.3	60	V
Voltage (buck function: BuckA and BuckB)	Ground: PGND–AGND, PGND–AGND	-0.3	0.3	V
	Enable inputs: ENA, ENB	-0.3	60	
	Bootstrap inputs: CBA, CBB	-0.3	68	
	Bootstrap inputs: CBA–PHA, CBB–PHB	-0.3	8.8	
	Phase inputs: PHA, PHB	-0.7	60	
	Phase inputs: PHA, PHB (for 150 ns)	-1	60	
	Feedback inputs: FBA, FBB	-0.3	13	
	Error-amplifier outputs: COMPA, COMPB	-0.3	13	
	High-side MOSFET drivers: GA1–PHA, GB1–PHB	-0.3	8.8	
	Low-side MOSFET drivers: GA2–PGND, GB2–PGND	-0.3	8.8	
	Current-sense voltage: SA1, SA2, SB1, SB2	-0.3	13	
	Soft start: SSA, SSB	-0.3	13	
	Power-good outputs: PGA, PGB	-0.3	13	
	Power-good delay: DLYAB	-0.3	13	
	Switching-frequency timing resistor: RT	-0.3	13	
SYNC, EXTSUP	-0.3	13		
Voltage (boost function)	Low-side MOSFET driver: GC1–PGND	-0.3	8.8	V
	Error-amplifier output: COMPC	-0.3	13	
	Enable input: ENC	-0.3	13	
	Current-limit sense: DS	-0.3	60	
	Output-voltage select: DIV	-0.3	8.8	
Voltage (PMOS driver)	P-channel MOSFET driver: GC2	-0.3	60	V
	P-channel MOSFET driver: VIN–GC2	-0.3	8.8	
Voltage (Gate-driver supply)	Gate-driver supply: VREG	-0.3	8.8	V
Temperature	Junction temperature: T <sub>J</sub>	-40	150	°C
	Operating temperature: T <sub>A</sub>	-40	125	
	Storage temperature: T <sub>stg</sub>	-55	165	

- (1) Stresses beyond those listed under *Absolute Maximum Ratings* may cause permanent damage to the device. These are stress ratings only, and functional operation of the device at these or any other conditions beyond those indicated under *Recommended Operating Conditions* is not implied. Exposure to absolute-maximum-rated conditions for extended periods may affect device reliability. All voltage values are with respect to AGND, unless otherwise specified.

### 6.2 ESD Ratings

		VALUE	UNIT		
V <sub>(ESD)</sub>	Electrostatic discharge	Human-body model (HBM), per AEC Q100-002 <sup>(1)</sup>	±2000	V	
		Charged-device model (CDM), per AEC Q100-011	All pins except 1, 19, 20, and 38		±500
			Pins 1, 19, 20, and 38		±750
		Machine model	All pins except 15 and 24		±200
			Pins 15 and 24		±150

- (1) AEC Q100-002 indicates that HBM stressing shall be in accordance with the ANSI/ESDA/JEDEC JS-001 specification.

### 6.3 Recommended Operating Conditions

		MIN	MAX	UNIT
Buck function: BuckA and BuckB voltage	Input voltage: VIN, VBAT	4	40	V
	Enable inputs: ENA, ENB	0	40	
	Boot inputs: CBA, CBB	4	48	
	Phase inputs: PHA, PHB	-0.6	40	
	Current-sense voltage: SA1, SA2, SB1, SB2	0	11	
	Power-good output: PGA, PGB	0	11	
	SYNC, EXTSUP	0	9	
Boost function	Enable input: ENC	0	9	V
	Voltage sense: DS		40	
	DIV	0	V <sub>REG</sub>	
Operating temperature: T <sub>A</sub>		-40	125	°C

### 6.4 Thermal Information

THERMAL METRIC <sup>(1)</sup>		TPS4333x-Q1		UNIT
		DAP (HTSSOP)		
		38 PINS		
R <sub>θJA</sub>	Junction-to-ambient thermal resistance <sup>(2)</sup>	27.3		°C/W
R <sub>θJctop</sub>	Junction-to-case (top) thermal resistance <sup>(3)</sup>	19.6		°C/W
R <sub>θJB</sub>	Junction-to-board thermal resistance <sup>(4)</sup>	15.9		°C/W
ψ <sub>JT</sub>	Junction-to-top characterization parameter <sup>(5)</sup>	0.24		°C/W
ψ <sub>JB</sub>	Junction-to-board characterization parameter <sup>(6)</sup>	6.6		°C/W
R <sub>θJcbot</sub>	Junction-to-case (bottom) thermal resistance <sup>(7)</sup>	1.2		°C/W

- (1) For more information about traditional and new thermal metrics, see the [Semiconductor and IC Package Thermal Metrics](#) application report.
- (2) The junction-to-ambient thermal resistance under natural convection is obtained in a simulation on a JEDEC-standard, high-K board, as specified in JESD51-7, in an environment described in JESD51-2a.
- (3) The junction-to-case (top) thermal resistance is obtained by simulating a cold plate test on the package top. No specific JEDEC-standard test exists, but a close description can be found in the ANSI SEMI standard G30-88.
- (4) The junction-to-board thermal resistance is obtained by simulating in an environment with a ring cold plate fixture to control the PCB temperature, as described in JESD51-8.
- (5) The junction-to-top characterization parameter, ψ<sub>JT</sub>, estimates the junction temperature of a device in a real system and is extracted from the simulation data for obtaining R<sub>θJA</sub>, using a procedure described in JESD51-2a (sections 6 and 7).
- (6) The junction-to-board characterization parameter, ψ<sub>JB</sub>, estimates the junction temperature of a device in a real system and is extracted from the simulation data for obtaining R<sub>θJA</sub>, using a procedure described in JESD51-2a (sections 6 and 7).
- (7) The junction-to-case (bottom) thermal resistance is obtained by simulating a cold plate test on the exposed (power) pad. No specific JEDEC standard test exists, but a close description can be found in the ANSI SEMI standard G30-88.

### 6.5 DC Electrical Characteristics

V<sub>IN</sub> = 8 V to 18 V, T<sub>J</sub> = -40°C to +150°C (unless otherwise noted)

PARAMETER		TEST CONDITIONS	MIN	TYP	MAX	UNIT
<b>INPUT SUPPLY</b>						
V <sub>BAT</sub>	Supply voltage	Boost controller enabled, after satisfying initial start-up condition	2		40	V
V <sub>IN</sub>	Input voltage required for device on initial start-up		6.5		40	V
	Buck regulator operating range after initial start-up		4		40	
V <sub>IN(UV)</sub>	Buck undervoltage lockout	V <sub>IN</sub> falling. After a reset, initial start-up conditions may apply. <sup>(1)</sup>	3.5	3.6	3.8	V
		V <sub>IN</sub> rising. After a reset, initial start-up conditions may apply. <sup>(1)</sup>		3.8	4	
V <sub>BOOST_UNLOCK</sub>	Boost unlock threshold	V <sub>BAT</sub> rising	8.2	8.5	8.8	V

- (1) If V<sub>BAT</sub> and V<sub>REG</sub> remain adequate, the buck can continue to operate if V<sub>IN</sub> is > 3.8 V.

**DC Electrical Characteristics (continued)**
 $V_{IN} = 8\text{ V to }18\text{ V}$ ,  $T_J = -40^\circ\text{C to }+150^\circ\text{C}$  (unless otherwise noted)

PARAMETER		TEST CONDITIONS	MIN	TYP	MAX	UNIT
$I_{O\_LPM}$	LPM quiescent current <sup>(2)</sup>	$V_{IN} = 13\text{ V}$ , $T_A = 25^\circ\text{C}$	BuckA: LPM, BuckB: off	30	40	$\mu\text{A}$
			BuckB: LPM, BuckA: off			
			BuckA, B: LPM,			
		$V_{IN} = 13\text{ V}$ , $T_A = 125^\circ\text{C}$	BuckA: LPM, BuckB: off	40	50	$\mu\text{A}$
			BuckB: LPM, BuckA: off			
			BuckA, B: LPM,			
$I_{O\_NRM}$	Quiescent current: normal (PWM) mode <sup>(2)</sup>	SYNC = HIGH, $T_A = 25^\circ\text{C}$ , $V_{IN} = 13\text{ V}$	BuckA: CCM, BuckB: off	4.85	5.3	mA
			BuckB: CCM, BuckA: off			
			BuckA, B: CCM			
		SYNC = HIGH, $T_A = 125^\circ\text{C}$ , $V_{IN} = 13\text{ V}$	BuckA: CCM, BuckB: off	5	5.5	mA
			BuckB: CCM, BuckA: off			
			BuckA, B: CCM			
$I_{bat\_sh}$	Shutdown current	BuckA, B: off, $V_{BAT} = 13\text{ V}$	$T_A = 25^\circ\text{C}$	2.5	4	$\mu\text{A}$
			$T_A = 125^\circ\text{C}$	3	5	$\mu\text{A}$
$V_{IN\_LPMexit}$	VIN level to exit LPM	$V_{IN}$ falling	7.7	8	8.3	V
$V_{IN\_LPMentry}$	VIN level to enable entering LPM	$V_{IN}$ rising	8.2	8.5	8.8	V
$V_{IN\_LPMhys}$	Hysteresis	$V_{IN}$ rising or falling	0.4	0.5	0.6	V
<b>INPUT VOLTAGE <math>V_{BAT}</math> - UNDERVOLTAGE LOCKOUT</b>						
$V_{BAT(UV)}$	Boost-input undervoltage	$V_{BAT}$ falling. After a reset, initial start-up conditions may apply. <sup>(1)</sup>	1.8	1.9	2	V
		$V_{BAT}$ rising. After a reset, initial start-up conditions may apply. <sup>(1)</sup>	2.4	2.5	2.6	
$UVLO_{Hys}$	Hysteresis		500	600	700	mV
$UVLO_{filter}$	Filter time			5		$\mu\text{s}$
<b>INPUT VOLTAGE <math>V_{IN}</math> - OVERVOLTAGE LOCKOUT</b>						
$V_{OVLO}$	Overvoltage shutdown	$V_{IN}$ rising	45	46	47	V
		$V_{IN}$ falling	43	44	45	
$OVLO_{Hys}$	Hysteresis		1	2	3	V
$OVLO_{filter}$	Filter time			5		$\mu\text{s}$
<b>BOOST CONTROLLER</b>						
$V_{boost7V}$	Boost $V_{OUT} = 7\text{ V}$	DIV = low, $V_{BAT} = 2\text{ V to }7\text{ V}$	6.8	7	7.3	V
$V_{boost7V-th}$	Boost-enable threshold	Boost $V_{OUT} = 7\text{ V}$	$V_{BAT}$ falling	7.5	8	8.5
	Boost-disable threshold		$V_{BAT}$ rising	8	8.5	9
	Boost hysteresis		$V_{BAT}$ rising or falling	0.4	0.5	0.6
$V_{boost10V}$	Boost $V_{OUT} = 10\text{ V}$	DIV = open, $V_{BAT} = 2\text{ V to }10\text{ V}$	9.7	10	10.4	V
$V_{boost10V-th}$	Boost-enable threshold	Boost $V_{OUT} = 10\text{ V}$	$V_{BAT}$ falling	10.5	11	11.5
	Boost-disable threshold		$V_{BAT}$ rising	11	11.5	12
	Boost hysteresis		$V_{BAT}$ rising or falling	0.4	0.5	0.6
$V_{boost8.85V}$	Boost $V_{OUT} = 8.85\text{ V}$	DIV = $V_{REG}$ , $V_{BAT} = 2\text{ V to }8.85\text{ V}$	8.35	8.85	9.35	V

(2) Quiescent current specification is non-switching current consumption without including the current in the external-feedback resistor divider.

## DC Electrical Characteristics (continued)

 $V_{IN} = 8\text{ V to }18\text{ V}$ ,  $T_J = -40^\circ\text{C to }+150^\circ\text{C}$  (unless otherwise noted)

PARAMETER		TEST CONDITIONS	MIN	TYP	MAX	UNIT	
$V_{\text{boost}8.85\text{V-th}}$	Boost-enable threshold	Boost $V_{\text{OUT}} = 8.85\text{ V}$	$V_{\text{BAT}}$ falling	9.15	9.85	10.45	V
	Boost-disable threshold		$V_{\text{BAT}}$ rising	9.65	10.35	10.85	
	Boost hysteresis		$V_{\text{BAT}}$ rising or falling	0.4	0.5	0.6	
<b>BOOST-SWITCH CURRENT LIMIT</b>							
$V_{\text{DS}}$	Current-limit sensing	DS input with respect to PGND A	0.175	0.2	0.225	V	
$t_{\text{DS}}$	Leading-edge blanking			200		ns	
<b>GATE DRIVER FOR BOOST CONTROLLER</b>							
$I_{\text{GC1 Peak}}$	Gate-driver peak current			1.5		A	
$r_{\text{DS(on)}}$	Source and sink driver	$V_{\text{REG}} = 5.8\text{ V}$ , $I_{\text{GC1}}$ current = 200 mA			2	$\Omega$	
<b>GATE DRIVER FOR PMOS</b>							
$r_{\text{DS(on)}}$	PMOS OFF			10	20	$\Omega$	
$I_{\text{PMOS\_ON}}$	Gate current	$V_{\text{IN}} = 13.5\text{ V}$ , $V_{\text{GS}} = -5\text{ V}$	10			mA	
$t_{\text{delay\_ON}}$	Turnon delay	$C = 10\text{ nF}$		5	10	$\mu\text{s}$	
<b>BOOST-CONTROLLER SWITCHING FREQUENCY</b>							
$f_{\text{sw-Boost}}$	Boost switching frequency			$f_{\text{SW\_Buck}} / 2$		kHz	
$D_{\text{Boost}}$	Boost duty cycle				90%		
<b>ERROR AMPLIFIER (OTA) FOR BOOST CONVERTERS</b>							
$G_{\text{mBOOST}}$	Forward transconductance	$V_{\text{BAT}} = 12\text{ V}$	0.8		1.35	mS	
		$V_{\text{BAT}} = 5\text{ V}$	0.35		0.65		
<b>BUCK CONTROLLERS</b>							
$V_{\text{BuckA}}$ or $V_{\text{BuckB}}$	Adjustable output-voltage range		0.9		11	V	
$V_{\text{ref, NRM}}$	Internal reference and tolerance voltage in normal mode	Measure FBx pin	0.792	0.8	0.808	V	
			-1%		1%		
$V_{\text{ref, LPM}}$	Internal reference and tolerance voltage in low-power mode	Measure FBx pin	0.784	0.8	0.816	V	
			-2%		2%		
$V_{\text{sense}}$	V sense for forward-current limit in CCM	Measured across Sx1 and Sx2, FBx = 0.75 V (low duty-cycle)	60	75	90	mV	
	V sense for reverse-current limit in CCM	Measured across Sx1 and Sx2, FBx = 1 V	-65	-37.5	-23		
$V_{\text{I-Foldback}}$	V sense for output short	Measured across Sx1 and Sx2, FBx = 0 V	17	32.5	48	mV	
$t_{\text{dead}}$	Shoot-through delay, blanking time			20		ns	
$DC_{\text{NRM}}$	High-side minimum ON-time			100		ns	
	Maximum duty cycle (digitally controlled)			98.75%			
$DC_{\text{LPM}}$	Duty cycle, LPM				80%		
$I_{\text{LPM\_Entry}}$	LPM entry-threshold load current as fraction of maximum set load current			1%	(3)		
$I_{\text{LPM\_Exit}}$	LPM exit-threshold load current as fraction of maximum set load current		See (3)	10%			
<b>HIGH-SIDE EXTERNAL NMOS GATE DRIVERS FOR BUCK CONTROLLER</b>							
$I_{\text{GX1\_peak}}$	Gate-driver peak current			1.5		A	
$r_{\text{DS(on)}}$	Source and sink driver	$V_{\text{REG}} = 5.8\text{ V}$ , $I_{\text{GX1}}$ current = 200 mA			2	$\Omega$	
<b>LOW-SIDE NMOS GATE DRIVERS FOR BUCK CONTROLLER</b>							
$I_{\text{GX2\_peak}}$	Gate-driver peak current			1.5		A	
$r_{\text{DS ON}}$	Source and sink driver	$V_{\text{REG}} = 5.8\text{ V}$ , $I_{\text{GX2}}$ current = 200 mA			2	$\Omega$	

(3) The exit threshold specification is to be always higher than the entry threshold.

## DC Electrical Characteristics (continued)

 $V_{IN} = 8\text{ V to }18\text{ V}$ ,  $T_J = -40^\circ\text{C to }+150^\circ\text{C}$  (unless otherwise noted)

PARAMETER		TEST CONDITIONS	MIN	TYP	MAX	UNIT
<b>ERROR AMPLIFIER (OTA) FOR BUCK CONVERTERS</b>						
$G_{mBUCK}$	Transconductance	COMP <sub>A</sub> , COMP <sub>B</sub> = 0.8 V, source/sink = 5 $\mu$ A, test in feedback loop	0.72	1	1.35	mS
<b>DIGITAL INPUTS: ENA, ENB, ENC, SYNC</b>						
$V_{IH}$	Higher threshold	$V_{IN} = 13\text{ V}$	1.7			V
$V_{IL}$	Lower threshold	$V_{IN} = 13\text{ V}$			0.7	V
$R_{IH\_SYNC}$	Pulldown resistance on SYNC	$V_{SYNC} = 5\text{ V}$	500			k $\Omega$
$R_{IL\_ENC}$	Pulldown resistance on ENC	$V_{ENC} = 5\text{ V}$	500			k $\Omega$
$I_{IL\_ENx}$	Pullup current source on ENA, ENB	$V_{ENx} = 0\text{ V}$	0.5		2	$\mu$ A
<b>BOOST OUTPUT VOLTAGE: DIV</b>						
$V_{IH\_DIV}$	Higher threshold	$V_{REG} = 5.8\text{ V}$	$V_{REG} - 0.2$			V
$V_{IL\_DIV}$	Lower threshold				0.2	V
$V_{oz\_DIV}$	Voltage on DIV if unconnected	Voltage on DIV if unconnected	$V_{REG} / 2$			V
<b>INTERNAL GATE-DRIVER SUPPLY</b>						
$V_{REG}$	Internal regulated supply	$V_{IN} = 8\text{ V to }18\text{ V}$ , $V_{EXTSUP} = 0\text{ V}$ , SYNC = high	5.5	5.8	6.1	V
	Load regulation	$I_{VREG} = 0\text{ mA to }100\text{ mA}$ , $V_{EXTSUP} = 0\text{ V}$ , SYNC = high	0.2%		1%	
$V_{REG(EXTSUP)}$	Internal regulated supply	$V_{EXTSUP} = 8.5\text{ V}$	7.2	7.5	7.8	V
	Load regulation	$I_{EXTSUP} = 0\text{ mA to }125\text{ mA}$ , SYNC = High $V_{EXTSUP} = 8.5\text{ V to }13\text{ V}$	0.2%		1%	
$V_{EXTSUP-th}$	EXTSUP switch-over voltage threshold	$I_{VREG} = 0\text{ mA to }100\text{ mA}$ , $V_{EXTSUP}$ ramping positive	4.4	4.6	4.8	V
$V_{EXTSUP-Hys}$	EXTSUP switch-over hysteresis		150		250	mV
$I_{VREG-Limit}$	Current limit on VREG	$V_{EXTSUP} = 0\text{ V}$ , normal mode as well as LPM	100		400	mA
$I_{VREG\_EXTSUP-Limit}$	Current limit on VREG when using EXTSUP	$I_{VREG} = 0\text{ mA to }100\text{ mA}$ , $V_{EXTSUP} = 8.5\text{ V}$ , SYNC = High	125		400	mA
<b>SOFT START</b>						
$I_{SSx}$	Soft-start source current	$V_{SSA}$ and $V_{SSB} = 0\text{ V}$	40	50	60	$\mu$ A
<b>OSCILLATOR (RT)</b>						
$V_{RT}$	Oscillator reference voltage		1.2			V
<b>POWER GOOD / DELAY</b>						
$PG_{th1}$	Power-good threshold	FBx falling	-5%	-7%	-9%	
$PG_{hys}$	Hysteresis		2%			
$PG_{drop}$	Voltage drop	$I_{PGA} = 5\text{ mA}$			450	mV
		$I_{PGA} = 1\text{ mA}$			100	
$PG_{leak}$	Power-good leakage	$V_{Sx2} = V_{PGx} = 13\text{ V}$			1	$\mu$ A
$t_{deglitch}$	Power-good deglitch time		2		16	$\mu$ s
$t_{delay}$	Reset delay	External capacitor = 1 nF $V_{BUCKX} < PG_{th1}$	1			ms
$t_{delay\_fix}$	Fixed reset delay	No external capacitor, pin open	20		50	$\mu$ s
$I_{OH}$	Activate current source (current to charge external capacitor)		30	40	50	$\mu$ A
$I_{IL}$	Activate current sink (current to discharge external capacitor)		30	40	50	$\mu$ A
<b>OVERTEMPERATURE PROTECTION</b>						
$T_{shutdown}$	Junction-temperature shutdown threshold		150	165		$^\circ\text{C}$
$T_{hys}$	Junction-temperature hysteresis		15			$^\circ\text{C}$

## 6.6 Switching Characteristics

over operating free-air temperature range (unless otherwise noted)

PARAMETER		TEST CONDITIONS		MIN	TYP	MAX	UNIT
<b>SWITCHING PARAMETER – BUCK DC-DC CONTROLLERS</b>							
f <sub>SW_Buck</sub>	Buck switching frequency	RT	GND	360	400	440	kHz
			60-kΩ external resistor				
f <sub>SW_adj</sub>	Buck adjustable range with external resistor	RT pin: external resistor		150		600	kHz
f <sub>SYNC</sub>	Buck synchronization range	External clock input		150		600	kHz

### 6.7 Typical Characteristics

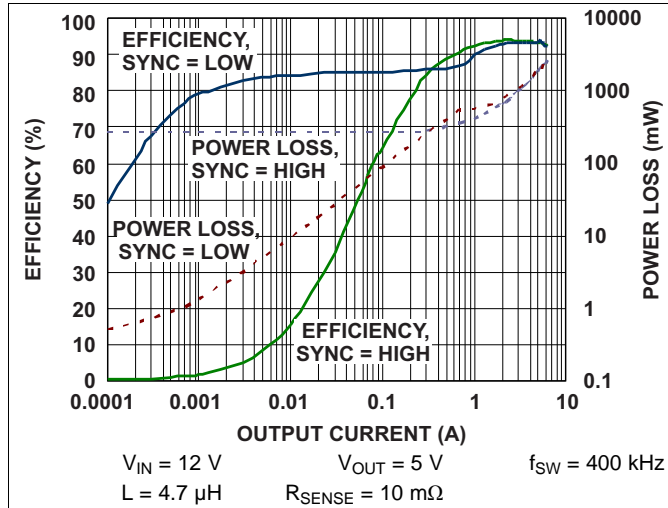

Figure 1. Efficiency Across Output Currents (Bucks)

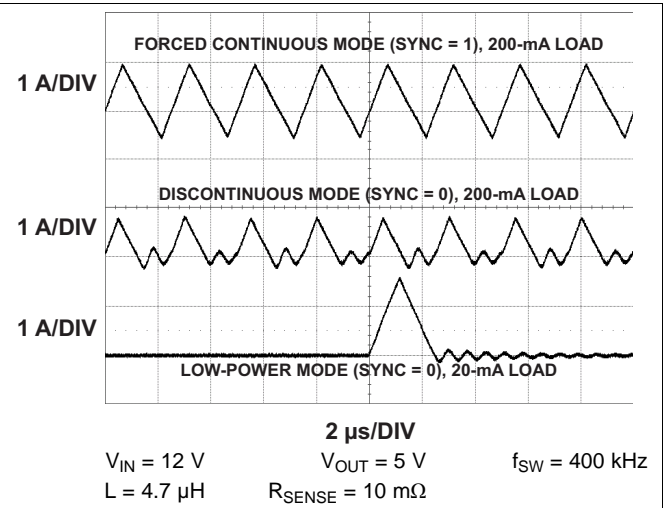

Figure 2. Inductor Currents (Buck)

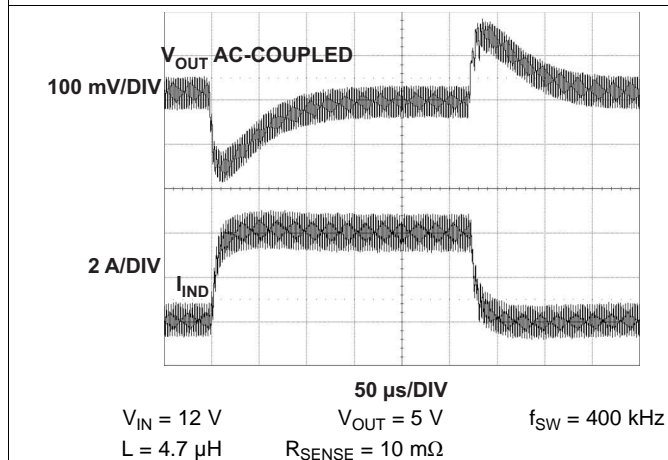

Figure 3. Buck Load Step: Forced Continuous Mode, 0 to 4 A at 2.5 A/μs

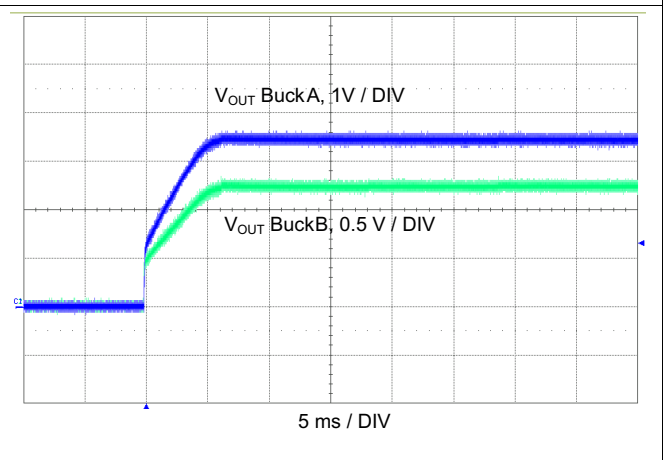

Figure 4. Soft-Start Outputs (Buck)

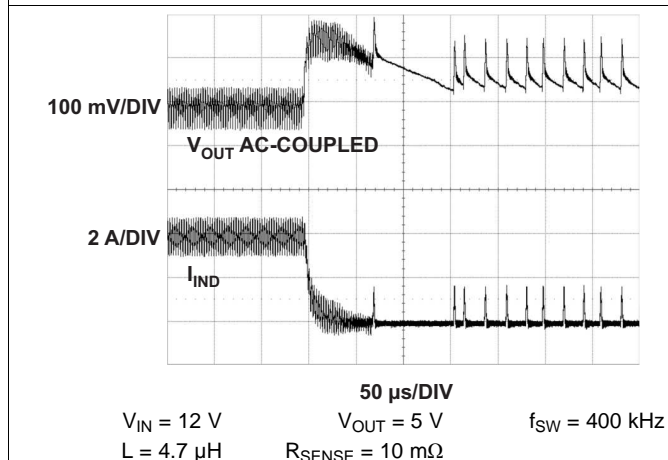

Figure 5. Buck Load Step: Low-Power-Mode Entry, 4 A to 90 mA at 2.5 A/μs

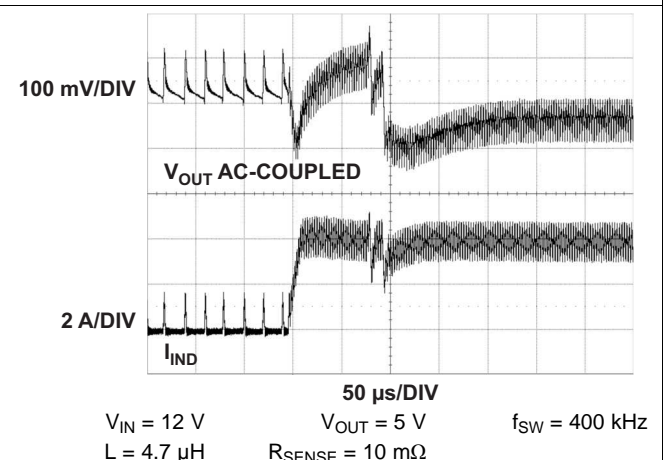

Figure 6. Buck Load Step: Low-Power-Mode Exit, 90 mA to 4 A at 2.5 A/μs

Typical Characteristics (continued)

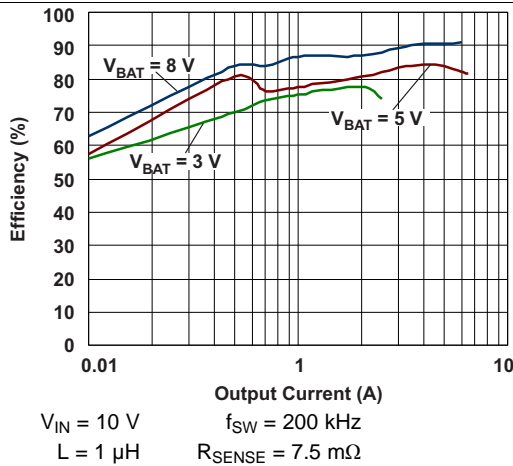

Figure 7. Efficiency Across Output Currents (Boost)

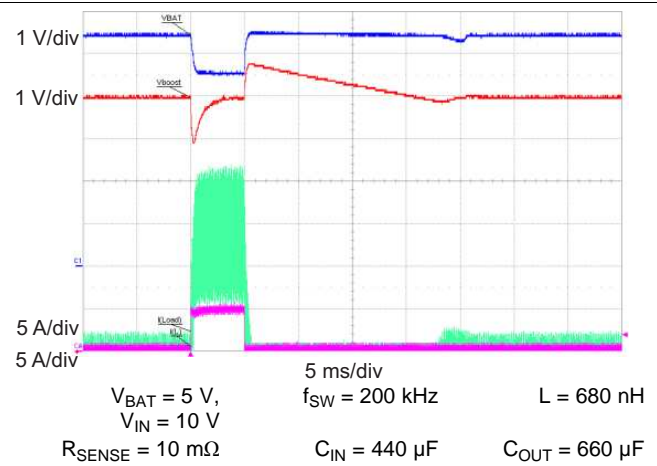

Figure 8. Load Step Response (Boost)  
(0 A to 5 A at 10 A/µs)

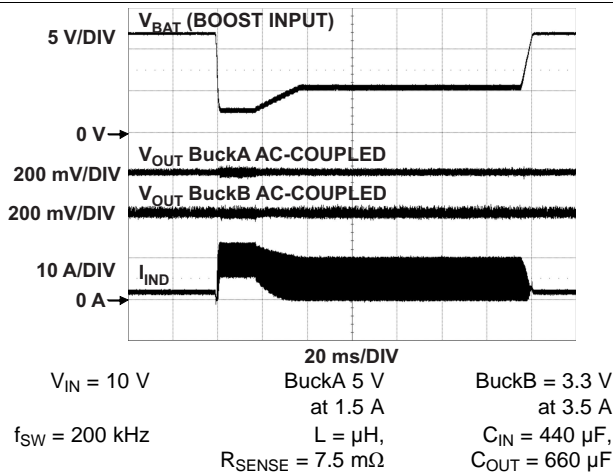

Figure 9. Cranking-Pulse Boost Response (12 V to 3 V in 1 ms at Buck Outputs 7.5 W and 11.5 W)

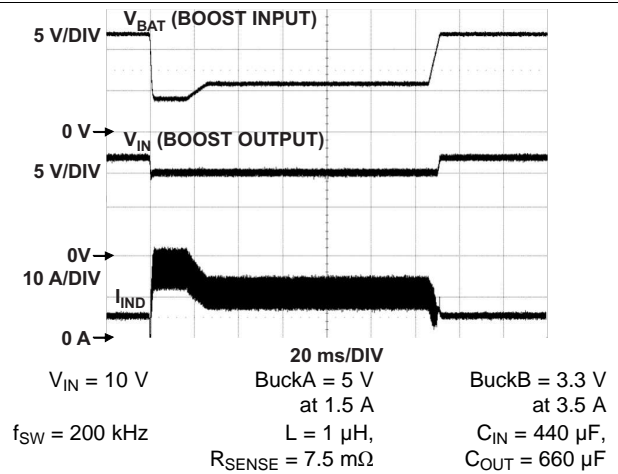

Figure 10. Cranking-Pulse Boost Response (12 V to 4 V in 1 ms at Boost Direct Output 25 W)

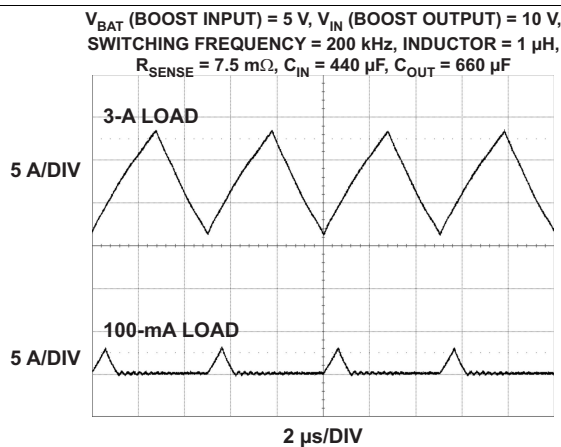

Figure 11. Inductor Currents (Boost)

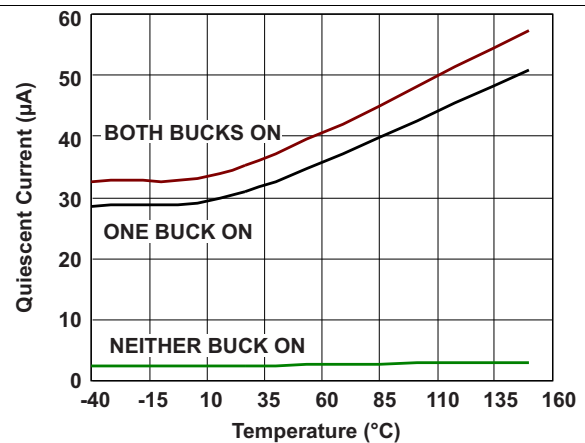

Figure 12. No-Load Quiescent Current vs Temperature

Typical Characteristics (continued)

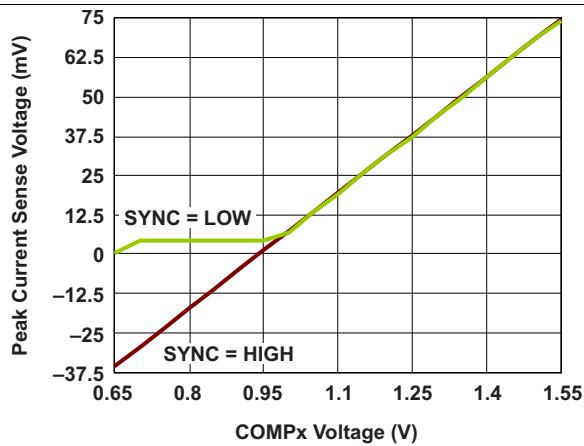

Figure 13. BUCKx Peak Current Limit vs COMPx Voltage

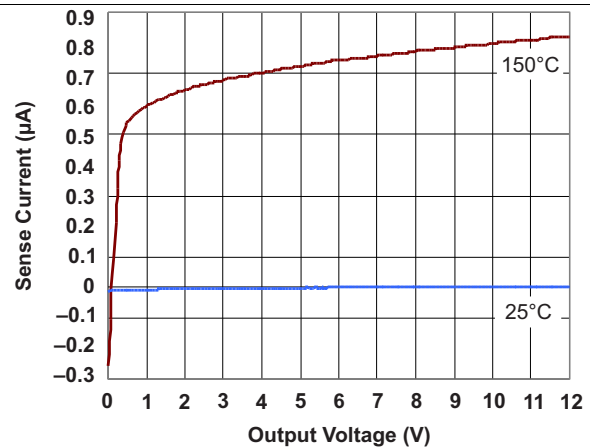

Figure 14. Current-Sense Pins Input Current (Buck)

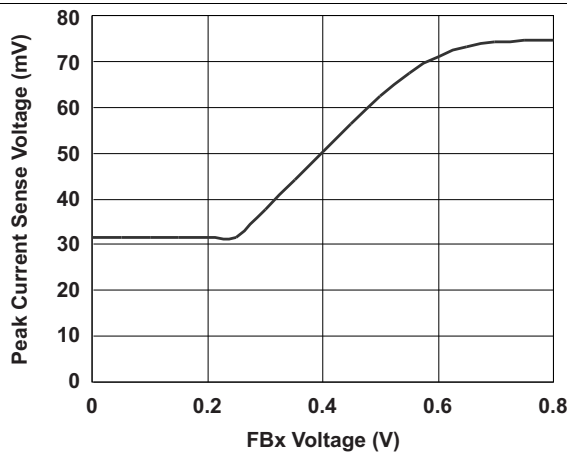

Figure 15. Foldback Current Limit (Buck)

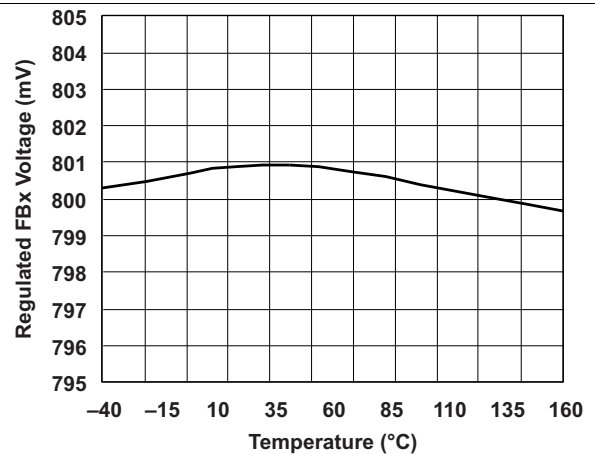

Figure 16. Regulated FBx Voltage vs Temperature (Buck)

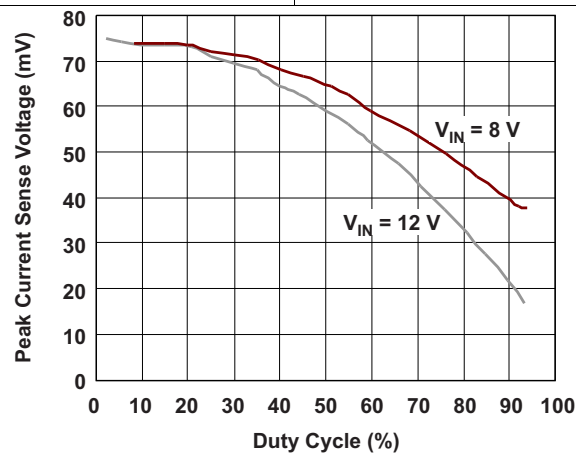

Figure 17. Current Limit vs Duty Cycle (Buck)

## 7 Detailed Description

### 7.1 Overview

The TPS43330A-Q1 includes two current-mode synchronous-buck controllers and a voltage-mode boost controller. The device is ideally suited as a preregulator stage with low IQ requirements and for applications that must operate during supply drops due to cranking events. The integrated boost controller allows the device to operate down to 2 V at the input without seeing a drop on the buck regulator output stages. At light loads, the buck controllers enable to operate automatically in low-power mode, consuming just 30  $\mu$ A of quiescent current.

The buck controllers have independent soft-start capability and power-good indicators. Current foldback in the buck controllers and cycle-by-cycle current limitation in the boost controller provide external MOSFET protection. The switching frequency is programmable over 150 kHz to 600 kHz or is synchronized to an external clock in the same range.

## 7.2 Functional Block Diagram

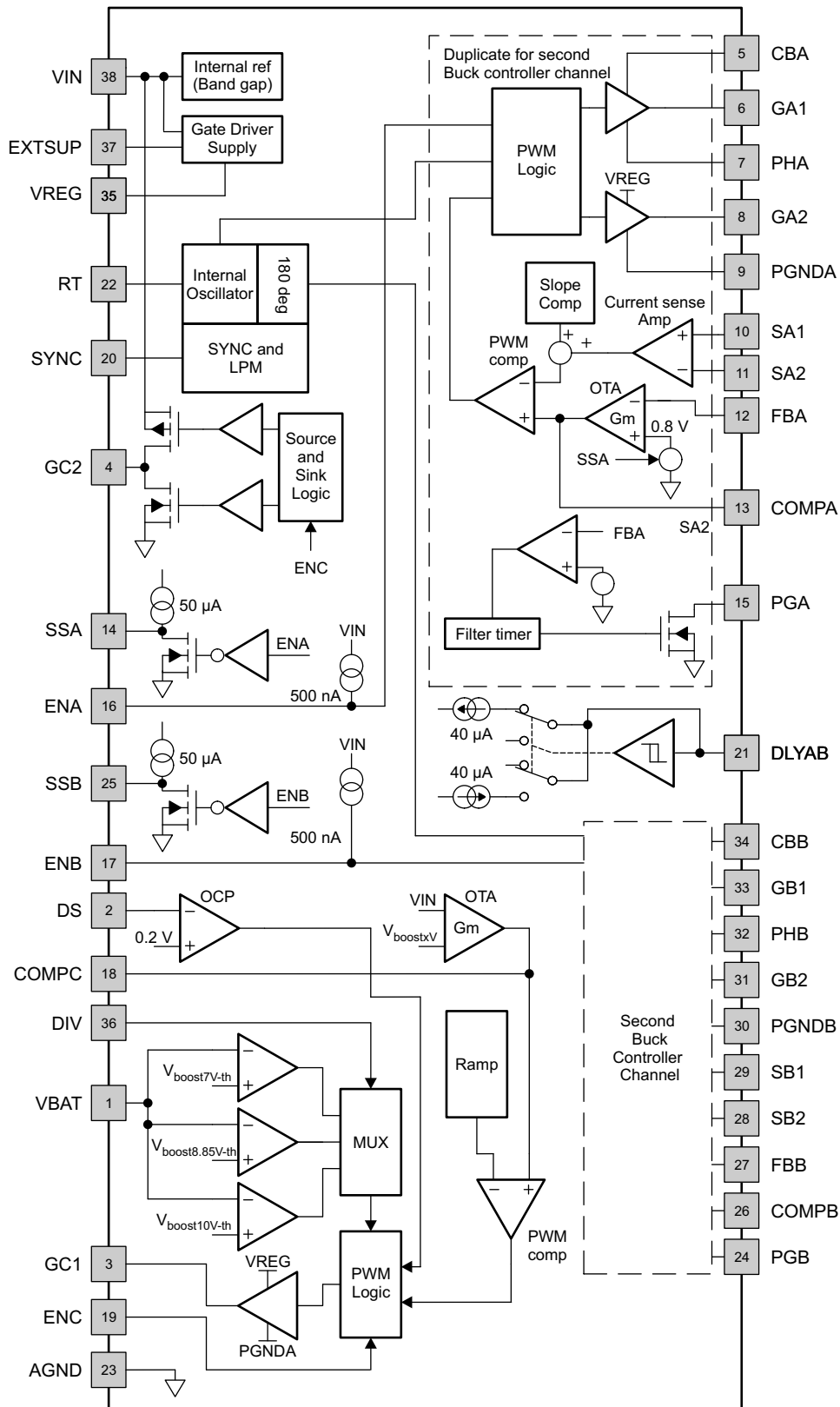

Copyright © 2016, Texas Instruments Incorporated

## 7.3 Feature Description

### 7.3.1 Boost Controller

The boost controller has a fixed-frequency voltage-mode architecture and includes cycle-by-cycle current-limit protection for the external N-channel MOSFET. The boost-controller switching-frequency setting is one-half of the buck-controller switching frequency. An internal resistor-divider network programmable to 7 V, 8.85 V, or 10 V sets the output voltage of the boost controller at the VIN pin, based on the low, open, or high status, respectively, of the DIV pin (see Table 1). The device does not recognize a change of the DIV setting while in the low-power mode.

**Table 1. Output Voltage Settings**

DIV SETTING	BOOST OUTPUT VOLTAGE
Low	7 V
Open	8.85 V
High	10 V

The active-high ENC pin enables the boost controller, which is active when the input voltage at the VBAT pin has crossed the boost unlock threshold (VBOOST\_UNLOCK) of 8.5 V at least once. A single high-to-low transition of  $V_{BAT}$  below the boost-enable threshold ( $V_{boost(x)-th}$ ) arms the boost controller, which starts switching as soon as  $V_{IN}$  falls below the value set by the DIV pin, regulating the VIN voltage. Thus, the boost regulator maintains a stable input voltage for the buck regulators during transient events such as a cranking pulse at VBAT.

A voltage at the DS pin exceeding 200 mV pulls the GC1 pin low, turning off the boost external MOSFET. Connecting the DS pin to the drain of the MOSFET or to a sense resistor between the MOSFET source and ground achieves cycle-by-cycle overcurrent protection for the MOSFET. Choose the ON-resistance of the MOSFET or the value of the sense resistor in such a way that the ON-state voltage at DS does not exceed 200 mV at the maximum-load and minimum-input-voltage conditions. When using a sense resistor, TI recommends connecting a filter network between the DS pin and the sense resistor for better noise immunity.

The boost output (VIN) supplies other circuits in the system; however, they should be high-voltage tolerant. The device regulates the boost output to the programmed value only when  $V_{BAT}$  is low, and so  $V_{IN}$  reaches battery levels.

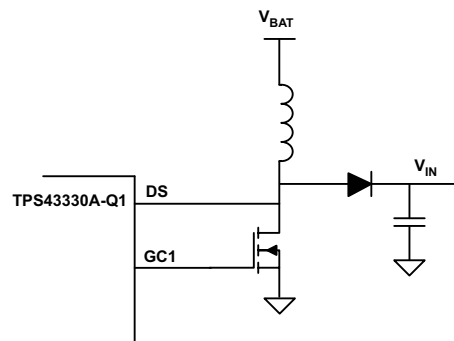

**Figure 18. External Drain-Source Voltage Sensing**

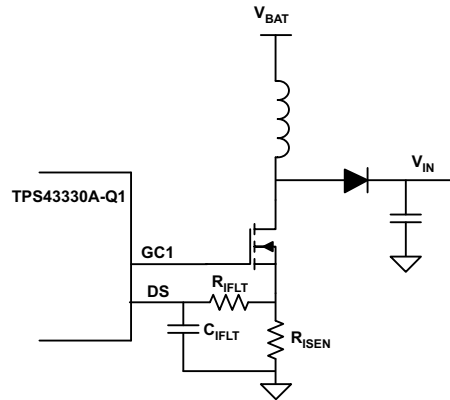

Figure 19. External Current Shunt Resistor

Table 2. Mode Control

SYNC TERMINAL	COMMENTS
External clock	Device in forced-continuous mode, internal PLL locks into external clock between 150 and 600 kHz.
Low or open	Device enters discontinuous mode. Automatic LPM entry and exit, depending on load conditions
High	Device in forced continuous mode

### 7.3.2 Gate-Driver Supply (VREG, EXTSUP)

The gate-driver supplies of the buck and boost controllers are from an internal linear regulator whose output (5.8 V typical) is on the VREG pin and requires decoupling with a ceramic capacitor in the range of 3.3 to 10  $\mu$ F. This pin has internal current-limit protection; do not use it to power any other circuits.

**NOTE**

VREG is not powered if no regulator is enabled, therefore it is not suitable to enable the regulators.

VIN powers the VREG linear regulator by default when the EXTSUP voltage is lower than 4.6 V (typical). If there is an expectation of V<sub>IN</sub> going to high levels, an excessive power dissipation occurs in this regulator, especially at high switching frequencies and when using large external MOSFETs. In this case, powering this regulator from the EXTSUP pin, which has a connection to a supply lower than V<sub>IN</sub> but high enough to provide the gate drive, is advantageous. When the voltage on EXTSUP is greater than 4.6 V, the linear regulator automatically switches to EXTSUP as its input, to provide this advantage. Efficiency improvements are possible when using one of the switching regulator rails from the TPS43330A-Q1 or any other voltage available in the system to power EXTSUP. The maximum voltage for application to EXTSUP is 9 V.

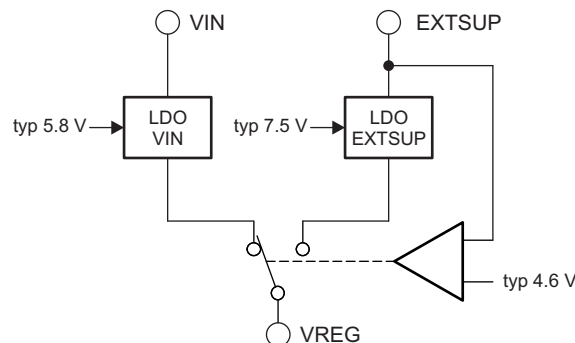

Figure 20. Internal Gate-Driver Supply

Using a voltage above 5.8 V (sourced by VIN) for EXTSUP is advantageous, as this voltage provides a large gate drive and hence better ON-resistance of the external MOSFETs.

During low-power mode, the EXTSUP functionality is unavailable. The internal regulator operates as a shunt regulator powered from VIN and has a typical value of 7.5 V. Current-limit protection for VREG is available in low-power mode as well. If EXTSUP is unused, leave the pin open without a capacitor installed.

### 7.3.3 External P-Channel Drive (GC2) and Reverse Battery Protection

The TPS43330A-Q1 includes a gate driver for an external P-channel MOSFET which can connect across the rectifier diode of the boost regulator. Such connection is useful to reduce power losses when the boost controller is not switching. The gate driver provides a swing of 6 V typical below the VIN voltage in order to drive a P-channel MOSFET. When  $V_{BAT}$  falls below the boost-enable threshold, the gate driver turns off the P-channel MOSFET, eliminating the diode bypass.

Another use for the gate driver is to bypass any additional protection diodes connected in series, as shown in Figure 21.

The bypass-design should be chosen with the following considerations in mind:

- The FETs must have a current-rating to support the maximum output power at minimum voltage (before Boost gets activated, typically 1 V above the set boost-voltage). The FETs' drain-source voltage also must support the worst-case transients on  $V_{BAT}$ , potentially causing a reverse voltage due to capacitors on the source.
- The Zener diode protects the FET against an excessive gate-source voltage. Typically a rating of approximately 7.5 V is suitable.
- The resistor limits the current to the FET and over the diode. Considering the deep boost mode and a high boost-output voltage, up to 9 V may be present between GC2 and  $V_{BAT}$ , reduced by the Zener voltage. As GC2 has a drive capability of 10 mA, the current must be limited by a series resistance of about 1 k $\Omega$  (depending on  $V_{BAT}(\min)$ ,  $V(\text{boost})$  and Zener voltage).

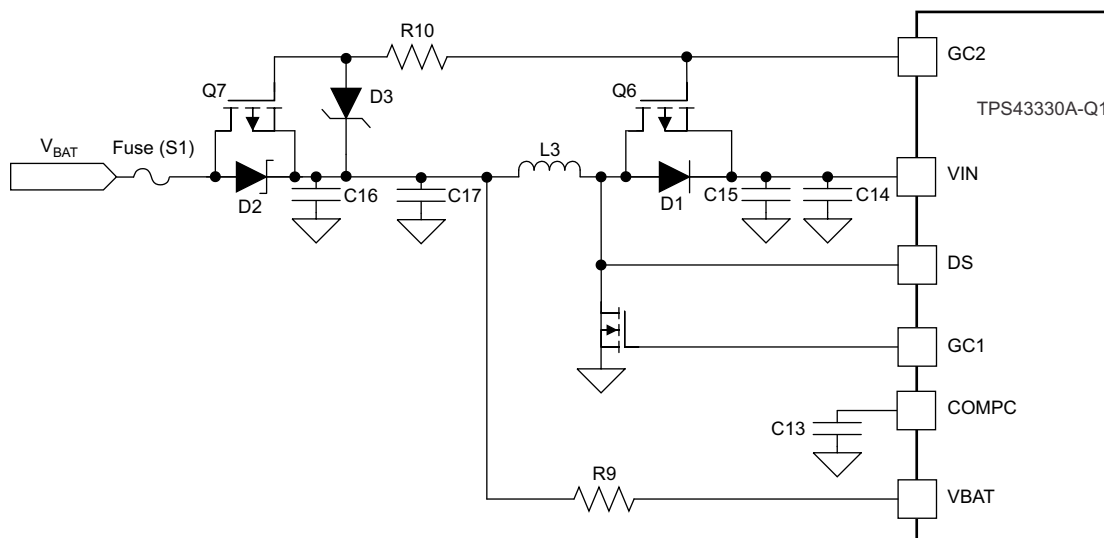
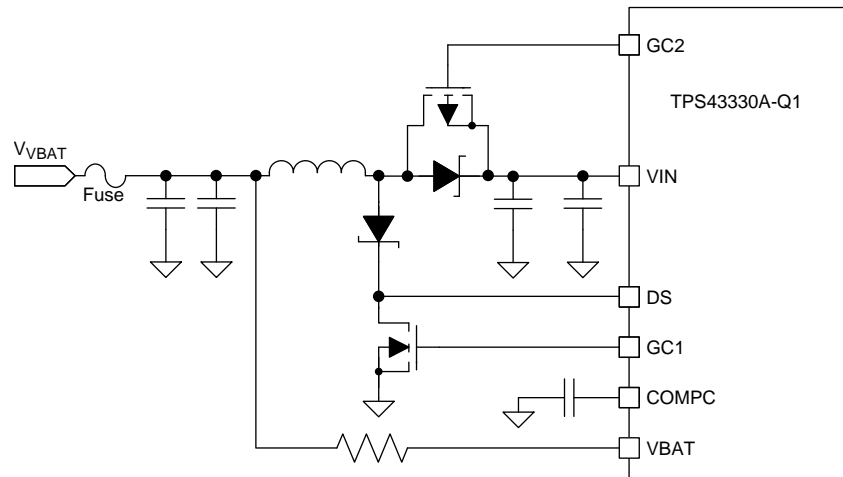

Figure 21. Reverse Battery Protection Option 1 for Buck Boost Configuration

Figure 22 also shows a different scheme of reverse battery protection, which may require only a smaller-sized diode to protect the N-channel MOSFET, as the diode conducts only for a part of the switching cycle. Because the diode is not always in the series path, the system efficiency can be improved.

#### NOTE

Be aware that VBAT-pin is not protected against reverse polarity in this configuration.



**Figure 22. Reverse Battery Protection Option 2 for Buck Boost Configuration**

### 7.3.4 Undervoltage Lockout and Overvoltage Protection

The TPS43330A-Q1 starts up at a  $V_{IN}$  voltage of 6.5 V (minimum), required for the internal supply (VREG). Once the device starts up, it operates down to a  $V_{IN}$  voltage of 3.6 V; below this voltage level, the undervoltage lockout disables the device.

#### NOTE

If  $V_{IN}$  drops,  $V_{REG}$  drops as well which reduces the gate-drive voltage, whereas the digital logic is fully functional. Even if ENC is high, there is a requirement to exceed the boost-unlock voltage of typically 8.5 V once, before boost activation takes place (see [Boost Controller](#)).

A voltage of 46 V at  $V_{IN}$  triggers the overvoltage comparator, which shuts down the device. In order to prevent transient spikes from shutting down the device, the undervoltage and overvoltage protection have filter times of 5  $\mu$ s (typical).

When the voltages return to the normal-operating region, the enabled switching regulators start including a new soft-start ramp for the buck regulators.

With the boost controller enabled, a voltage less than 1.9 V (typical) on VBAT triggers an undervoltage lockout and pulls the boost-gate driver (GC1) low (this action has a filter delay of 5  $\mu$ s, typical). As a result,  $V_{IN}$  falls at a rate dependent on the capacitor and load, eventually triggering  $V_{IN}$  undervoltage. A short-falling transient at VBAT even lower than 2 V thus survives if  $V_{BAT}$  returns above 2.5 V before  $V_{IN}$  discharges to the undervoltage threshold.

### 7.3.5 Thermal Protection

The TPS43330A-Q1 protects from overheating using an internal thermal-shutdown circuit. If the die temperature exceeds the thermal-shutdown threshold of 165°C due to excessive power dissipation (for example, due to fault conditions such as a short circuit at the gate drivers or VREG), the controllers turn off and then restart when the temperature falls by 15°C.

## 7.4 Device Functional Modes

Table 3 lists the functional modes of the TPS43330A-Q1.

**Table 3. Mode of Operation**

ENABLE AND INHIBIT PINS				DRIVER STATUS		DEVICE STATUS	QUIESCENT CURRENT
ENA	ENB	ENC	SYNC	BUCK CONTROLLERS	BOOST CONTROLLER		
Low	Low	Low	X	Shut down	Disabled	Shutdown	Approximately 4 $\mu$ A
Low	High	Low	Low	BuckB running	Disabled	BuckB: LPM enabled	Approximately 30 $\mu$ A (light loads)
			High			BuckB: LPM inhibited	mA range
High	Low	Low	Low	BuckA running	Disabled	BuckA: LPM enabled	Approximately 30 $\mu$ A (light loads)
			High			BuckA: LPM inhibited	mA range
High	High	Low	Low	BuckA and BuckB running	Disabled	BuckA and BuckB: LPM enabled	Approximately 35 $\mu$ A (light loads)
			High			BuckA and BuckB: LPM inhibited	mA range
Low	Low	Low	X	Shut down	Disabled	Shutdown	Approximately 4 $\mu$ A
Low	High	High	Low	BuckB running	Boost running for $V_{IN} <$ set boost output	BuckB: LPM enabled	Approximately 50 $\mu$ A (no boost, light loads)
			High			BuckB: LPM inhibited	mA range
High	Low	High	Low	BuckA running	Boost running for $V_{IN} <$ set boost output	BuckA: LPM enabled	Approximately 50 $\mu$ A (no boost, light loads)
			High			BuckA: LPM inhibited	mA range
High	High	High	Low	BuckA and BuckB running	Boost running for $V_{IN} <$ set boost output	BuckA and BuckB: LPM enabled	Approximately 60 $\mu$ A (no boost, light loads)
			High			BuckA and BuckB: LPM inhibited	mA range

### 7.4.1 Buck Controllers: Normal Mode PWM Operation

#### 7.4.1.1 Frequency Selection and External Synchronization

The buck controllers operate using constant-frequency peak-current-mode control for optimal transient behavior and ease of component choices. The switching frequency is programmable between 150 kHz and 600 kHz, depending upon the resistor value at the RT pin. A short-circuit to ground or a high impedance (open) at this pin sets the default switching frequency to 400 kHz. Using a resistor at RT, set another frequency according to Equation 1.

$$f_{sw} = \frac{X}{RT} \quad (X = 24 \text{ k}\Omega \times \text{MHz})$$

$$f_{sw} = 24 \times \frac{10^9}{RT} \quad (1)$$

For example,

600 kHz requires 40 k $\Omega$

150 kHz requires 160 k $\Omega$

Synchronizing to an external clock at the SYNC pin in the same frequency range of 150 kHz to 600 kHz is also possible. The device detects clock pulses at this pin, and an internal PLL locks on to the external clock within the specified range. The device also detects a loss of clock at this pin, and on detection of this condition, the device sets the switching frequency to the internal oscillator. The two buck controllers operate at identical switching frequencies, 180 degrees out-of-phase.

### 7.4.1.2 Enable Inputs

Independent enable inputs from the ENA and ENB pins enable the buck controllers. These are high-voltage pins, with a threshold of 1.7 V for the high level, and with which direct connection to the battery is permissible for self-bias. The low threshold is 0.7 V. These pins have internal pullup currents of 0.5  $\mu$ A (typical). As a result, an open circuit on these pins enables the respective buck controllers. When both buck controllers are disabled, the device shuts down and consumes a current of less than 4  $\mu$ A.

### 7.4.1.3 Feedback Inputs

The resistor-feedback divider network connected to the FBx (feedback) pins sets the output voltage. Choose this network such that the regulated voltage at the FBx pin equals 0.8 V. The FBx pins have a 100-nA pullup current source as a protection feature in case the pins open up as a result of physical damage.

### 7.4.1.4 Soft-Start Inputs

In order to avoid large inrush currents, each buck controller has an independent programmable soft-start timer. The voltage at the SSx pin acts as the soft-start reference voltage. The 1- $\mu$ A pullup current available at the SSx pins, in combination with a suitably chosen capacitor, generates a ramp of the desired soft-start speed. After start-up, the pullup current ensures that SSx is higher than the internal reference of 0.8 V; 0.8 V then becomes the reference for the buck controllers. [Equation 2](#) calculates the soft-start ramp time:

$$C_{SS} = \frac{I_{SS} \times \Delta t}{\Delta V} \quad (\text{Farads})$$

where,

- $I_{SS} = 50 \mu\text{A}$  (typical)
- $\Delta V = 0.8 \text{ V}$
- $C_{SS}$  is the required capacitor for  $\Delta t$ , the desired soft-start time (2)

An alternative use of the soft-start pins is as tracking inputs. In this case, connect them to the supply to be tracked through a suitable resistor-divider network.

### 7.4.1.5 Current-Mode Operation

Peak-current-mode control regulates the peak current through the inductor to maintain the output voltage at the set value. The error between the feedback voltage at FBx and the internal reference produces a signal at the output of the error amplifier (COMPx) which serves as the target for the peak inductor current. The device senses the current through the inductor as a differential voltage at Sx1–Sx2 and compares voltage with this target during each cycle. A fall or rise in load current produces a rise or fall in voltage at FBx, causing  $V_{COMPx}$  to fall or rise respectively, thus increasing or decreasing the current through the inductor until the average current matches the load. This process maintains the output voltage in regulation.

The top N-channel MOSFET turns on at the beginning of each clock cycle and stays on until the inductor current reaches the peak value. Once this MOSFET turns off, and after a small delay (shoot-through delay) the lower N-channel MOSFET turns on until the start of the next clock cycle. In dropout operation, the high-side MOSFET stays on continuously. In every fourth clock cycle, there is a limit on the duty cycle of 95% in order to charge the bootstrap capacitor at CBx, which allows a maximum duty cycle of 98.75% for the buck regulators. During dropout, the buck regulator switches at one-fourth of the normal frequency.

### 7.4.1.6 Current Sensing and Current Limit With Foldback

Clamping of the maximum value of COMPx limits the maximum current through the inductor to a specified value. When the output of the buck regulator (and hence the feedback value at FBx) falls to a low value due to a short circuit or overcurrent condition, the clamped voltage at COMPx successively decreases, thus providing current foldback protection, which protects the high-side external MOSFET from excess current (forward-direction current limit).

Similarly, if a fault condition shorts the output to a high voltage and the low-side MOSFET turns fully on, the COMPx node drops low. A clamp is on the lower end as well in order to limit the maximum current in the low-side MOSFET (reverse-direction current limit).

An external resistor senses the current through the inductor. Choose the sense resistor such that the maximum forward peak current in the inductor generates a voltage of 75 mV across the sense pins. This specified value is for low duty cycles only. At typical duty-cycle conditions around 40% (assuming 5-V output and 12-V input), 50 mV is a more reasonable value, considering tolerances and mismatches. The typical characteristics (see Figure 17) provide a guide for using the correct current-limit sense voltage.

The current-sense pins Sx1 and Sx2 are high-impedance pins with low leakage across the entire output range, thus allowing DCR current-sensing using the DC resistance of the inductor for higher efficiency. Figure 23 shows DCR sensing. Here, the series resistance (DCR) of the inductor is the sense element. Place the filter components close to the device for noise immunity. Remember that while the DCR sensing gives high efficiency, it is inaccurate due to the temperature sensitivity and a wide variation of the parasitic inductor series resistance. Hence, using the more-accurate sense resistor for current sensing is advantageous.

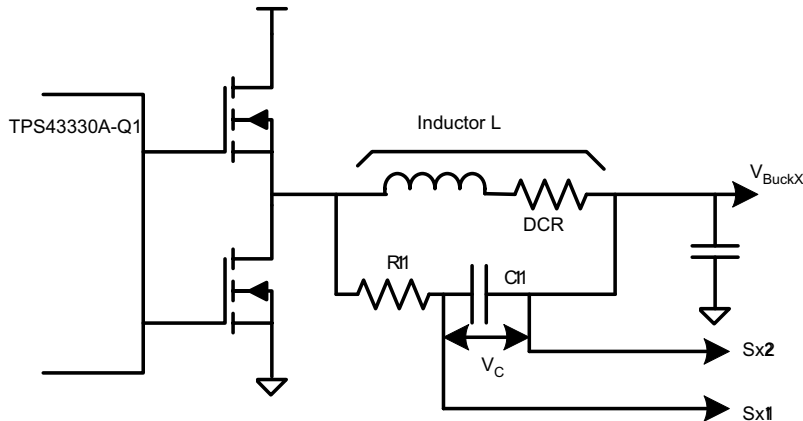

Figure 23. DCR Sensing Configuration

#### 7.4.1.7 Slope Compensation

Optimal slope compensation, which is adaptive to changes in input voltage and duty cycle, allows stable operation under all conditions. For optimal performance of this circuit, choose the inductor and sense resistor according to the following:

$$\frac{L \times f_{sw}}{R_s} = 200$$

where

- L is the buck-regulator inductor in henry
- $R_s$  is the sense resistor in ohms
- $f_{sw}$  is the buck-regulator switching frequency in hertz

(3)

#### 7.4.1.8 Power-Good Outputs and Filter Delays

Each buck controller has an independent power-good comparator monitoring the feedback voltage at the FBx pins and indicating whether the output voltage falls below a specified power-good threshold. This threshold has a typical value of 93% of the regulated output voltage. The power-good indicator is available as an open-drain output at the PGx pins. Shutdown of a buck controller causes an internal pulldown of the power-good indicator. Connecting the pullup resistor to a rail other than the output of that particular buck channel causes a constant-current flow through the resistor when the buck controller is powered down.

In order to avoid triggering the power-good indicators due to noise or fast transients on the output voltage, the device uses an internal delay circuit for de-glitching. Similarly, when the output voltage returns to the set value after a long negative transient, assertion of the power-good indicator (release of the open-drain pin) occurs after the same delay. Use of this delay pauses the release of the reset. Program the duration of the delay by using a suitable capacitor at the DLYAB pin according to Equation 4.

$$\frac{t_{DELAY}}{C_{DLYAB}} = \frac{1 \text{ msec}}{1 \text{ nF}}$$

(4)

When the DLYAB pin is open, the delay setting is for a default value of 20  $\mu\text{s}$  typical. The power-good delay timing is common to both the buck rails, but the power-good comparators and indicators function independently.

#### 7.4.1.9 Light-Load PFM Mode

An external clock or a high level on the SYNC pin results in forced continuous-mode operation of the bucks. An open or low on the SYNC pin allows the buck controllers to operate in discontinuous mode at light loads by turning off the low-side MOSFET on detection of a zero-crossing in the inductor current.

In discontinuous mode, as the load decreases, the duration when both the high-side and low-side MOSFETs turn off increases (deep-discontinuous mode). In case the duration exceeds 60% of the clock period and  $V_{\text{BAT}} > 8\text{ V}$ , the buck controller switches to a low-power operation mode. The design ensures that this switching typically occurs at 1% of the set full-load current if the choice of the inductor and sense resistor is as recommended in [Slope Compensation](#).

In low-power PFM mode, the buck monitors the FBx voltage and compares it with the 0.8-V internal reference. Whenever the FBx value falls below the reference, the high-side MOSFET turns on for a pulse duration inversely proportional to the difference  $V_{\text{IN}} - Sx2$ . At the end of this on-time, the high-side MOSFET turns off and the current in the inductor decays until the current becomes zero. The low-side MOSFET does not turn on. The next pulse occurs the next time FBx falls below the reference value. This pulsing results in a constant volt-second  $t_{\text{on}}$  hysteretic operation with a total device-quiescent current consumption of 30  $\mu\text{A}$  when a single-buck channel is active and of 35  $\mu\text{A}$  when both channels are active.

As the load increases, the pulses become more and more frequent and move closer to each other until the current in the inductor becomes continuous. At this point, the buck controller returns to normal fixed-frequency current-mode control. Another criterion to exit the low-power mode is when  $V_{\text{IN}}$  falls low enough to require higher than 80% duty cycle of the high-side MOSFET.

The TPS43330A-Q1 supports the full-current load during low-power mode until the transition to normal mode takes place. The design ensures that exit of the low-power mode occurs at 10% (typical) of full-load current if the selection of the inductor and sense resistor is as recommended. Moreover, a hysteresis always exists between the entry and exit thresholds to avoid oscillating between the two modes.

In the event that both buck controllers are active, low-power mode is only possible when both buck controllers have light loads that are low enough for low-power mode entry. With the boost controller enabled, low-power mode is possible only if  $V_{\text{BAT}}$  is high enough to prevent the boost from switching and if DIV is open or set to GND. A high ( $V_{\text{REG}}$ ) level on DIV inhibits low-power mode, unless ENC is set to low.

## 8 Application and Implementation

### NOTE

Information in the following applications sections is not part of the TI component specification, and TI does not warrant its accuracy or completeness. TI's customers are responsible for determining suitability of components for their purposes. Customers should validate and test their design implementation to confirm system functionality.

### 8.1 Application Information

The TPS43330A-Q1 is ideally suited as a pre-regulator stage with low I<sub>q</sub> requirements and for applications that must survive supply drops due to cranking events. The integrated boost controller allows the devices to operate down to 2 V at the input without seeing a drop on the buck regulator output stages. Below component values and calculations are a good starting point and theoretical representation of the values for use in the application; improving the performance of the device may require further optimization of the derived components.

### 8.2 Typical Application

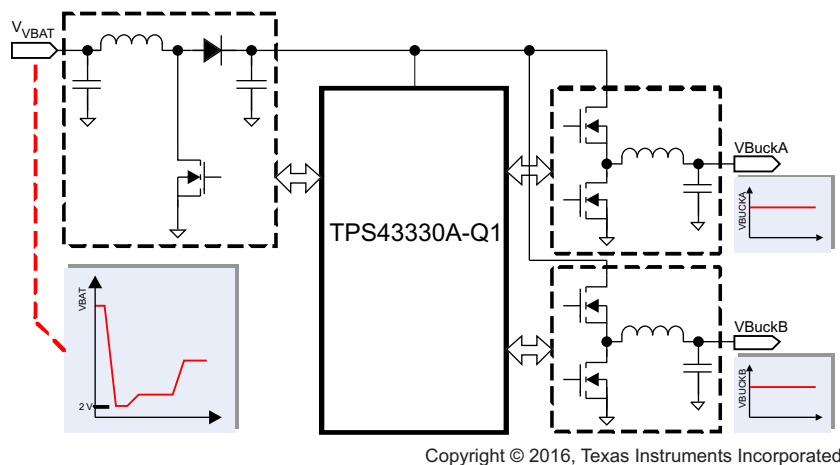

Figure 24. Typical Application Diagram

#### 8.2.1 Design Requirements

The following example illustrates the design process and component selection for the TPS43330A-Q1. [Table 4](#) lists the design-goal parameters.

Table 4. Application Example

PARAMETER	V <sub>BuckA</sub>	V <sub>BuckB</sub>	BOOST
Input voltage	V <sub>IN</sub> = 6 V to 30 V 12 V - typical	V <sub>IN</sub> = 6 V to 30 V 12 V - typical	V <sub>BAT</sub> = 5 V (cranking pulse input) to 30 V
Output voltage, V <sub>OUTx</sub>	5 V	3.3 V	10 V
Maximum output current, I <sub>OUTx</sub>	3 A	2 A	2.5 A
Load-step output tolerance, ΔV <sub>OUT</sub> + ΔV <sub>OUT(Ripple)</sub>	±0.2 V	±0.12 V	±0.5 V
Current output load-step, ΔI <sub>OUTx</sub>	0.1 to 3 A	0.1 to 2 A	0.1 to 2.5 A
Converter switching frequency, f <sub>SW</sub>	400 kHz	400 kHz	200 kHz

## 8.2.2 Detailed Design Procedure

### 8.2.2.1 Boost Component Selection

A boost converter operating in continuous-conduction mode (CCM) has a right-half-plane (RHP) zero in its transfer function. The RHP zero relates inversely to the load current and inductor value and directly to the input voltage. The RHP zero limits the maximum bandwidth achievable for the boost regulator. If the bandwidth is too close to the RHP zero frequency, the regulator becomes unstable.

Thus, for high-power systems with low input voltages, choose a low inductor value. A low value increases the amplitude of the ripple currents in the N-channel MOSFET, the inductor, and the capacitors for the boost regulator. Select these components with the ripple-to-RHP zero trade-off in mind and considering the power dissipation effects in the components due to parasitic series resistance.

A boost converter that operates always in the discontinuous mode does not contain the RHP zero in the transfer function. However, designing for the discontinuous mode demands an even lower inductor value that has high ripple currents. Also, ensure that the regulator never enters the continuous-conduction mode; otherwise, it becomes unstable.

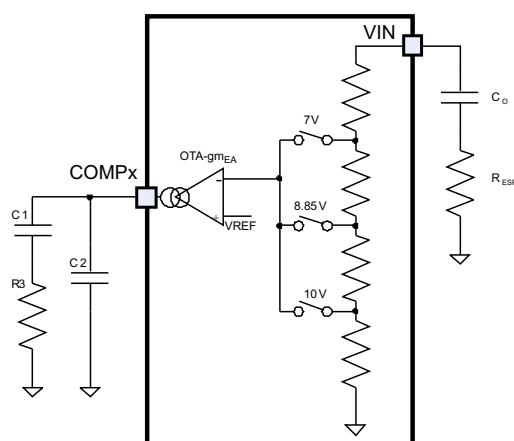

**Figure 25. Boost Compensation Components**

### 8.2.2.2 Boost Maximum Input Current $I_{IN\_MAX}$

The maximum input current flows at the minimum input voltage and maximum load. The efficiency for  $V_{BAT} = 5\text{ V}$  at 2.5 A is 80%, based on [Figure 7](#).

$$P_{INmax} = \frac{P_{OUT}}{\text{Efficiency}} = \frac{25\text{ W}}{0.8} = 31.3\text{ W} \quad (5)$$

Hence,

$$I_{INmax}(\text{at } V_{BAT} = 5\text{ V}) = \frac{31.3\text{ W}}{5\text{ V}} = 6.3\text{ A} \quad (6)$$

### 8.2.2.3 Boost Inductor Selection, $L$

Allow input ripple current of 40% of  $I_{IN\_max}$  at  $V_{BAT} = 5\text{ V}$ .

$$L = \frac{V_{BAT} \times t_{ON}}{I_{Nripplemax}} = \frac{V_{BAT}}{I_{Nripplemax} \times 2 \times f_{SW}} = \frac{5\text{ V}}{2.52\text{ A} \times 2 \times 200\text{ kHz}} = 4.9\text{ }\mu\text{H} \quad (7)$$

Choose a lower value of 4  $\mu\text{H}$  in order to ensure a high RHP-zero frequency while making a compromise that expects a high current ripple. This inductor selection also makes the boost converter operate in discontinuous conduction mode, where it is easier to compensate.

The inductor-saturation current must be higher than the peak-inductor current and some percentage higher than the maximum current-limit value set by the external resistive-sensing element.

Determine the saturation rating at the minimum input voltage, maximum output current, and maximum core temperature for the application.

#### 8.2.2.4 Inductor Ripple Current, $I_{RIPPLE}$

Based on an inductor value of 4  $\mu\text{H}$ , the ripple current is approximately 3.1 A.

#### 8.2.2.5 Peak Current in Low-Side FET, $I_{PEAK}$

$$I_{PEAK} = I_{INmax} + \frac{I_{RIPPLE}}{2} = 6.3 \text{ A} + \frac{3.1 \text{ A}}{2} = 7.85 \text{ A} \quad (8)$$

Based on this peak current value, calculate the external current-sense resistor  $R_{SENSE}$ .

$$R_{SENSE} = \frac{0.2 \text{ V}}{7.85 \text{ A}} = 25 \text{ m}\Omega \quad (9)$$

Select 20  $\text{m}\Omega$ , allowing for tolerance.

The filter component values  $R_{IFLT}$  and  $C_{IFLT}$  for current sense are 1.5  $\text{k}\Omega$  and 1 nF, respectively, which allows for good noise immunity.

#### 8.2.2.6 Right Half-Plane Zero RHP Frequency, $f_{RHP}$

$$f_{RHP} = \frac{V_{BATmin}}{2\pi \times I_{INmax} \times L} = 32 \text{ kHz} \quad (10)$$

#### 8.2.2.7 Output Capacitor, $C_{OUTx}$

To ensure stability, choose output capacitor  $C_{OUTx}$  such that

$$f_{LC} \leq \frac{f_{RHP}}{10}$$

$$\frac{10}{2\pi \times \sqrt{L \times C_{OUTx}}} \leq \frac{V_{BATmin}}{2\pi \times I_{INmax} \times L}$$

$$C_{OUTx} \geq \left( \frac{10 \times I_{INmax}}{V_{BATmin}} \right)^2 \times L = \left( \frac{10 \times 6.3 \text{ A}}{5 \text{ V}} \right)^2 \times 4 \mu\text{H}$$

$$C_{OUTx \min} \geq 635 \mu\text{F} \quad (11)$$

Select  $C_{OUTx} = 680 \mu\text{F}$ .

This capacitor is usually aluminum electrolytic with ESR in the tens-of-milliohms. ESR in this range is good for loop stability, because it provides a phase boost. The output filter components, L and C, create a double pole (180-degree phase shift) at a frequency  $f_{LC}$  and the ESR of the output capacitor  $R_{ESR}$  creates a zero for the modulator at frequency  $f_{ESR}$ . One can determine these frequencies by [Equation 12](#).

$$f_{\text{ESR}} = \frac{1}{2\pi \times C_{\text{OUTx}} \times R_{\text{ESR}}} \text{ Hz, assume } R_{\text{ESR}} = 40 \text{ m}\Omega$$

$$f_{\text{ESR}} = \frac{1}{2\pi \times 660 \mu\text{F} \times 0.04 \Omega} = 6 \text{ kHz}$$

$$f_{\text{LC}} = \frac{1}{2\pi \times \sqrt{L} \times C_{\text{OUTx}}} = \frac{1}{2\pi \times \sqrt{4 \mu\text{H}} \times 660 \mu\text{F}} = 3.1 \text{ kHz} \quad (12)$$

This satisfies  $f_{\text{LC}} \leq 0.1 f_{\text{RHP}}$ .

Potentially use a parallel configuration of smaller values to achieve this  $R_{\text{ESR}}$  or recalculate with the correct value.

### 8.2.2.8 Bandwidth of Boost Converter, $f_{\text{C}}$

Use the following guidelines to set the frequency poles, zeroes, and crossover values for the trade-off between stability and transient response:

$$f_{\text{LC}} < f_{\text{ESR}} < f_{\text{C}} < f_{\text{RHP Zero}}$$

$$f_{\text{C}} < f_{\text{RHP Zero}} / 3$$

$$f_{\text{C}} < f_{\text{SW}} / 6$$

$$f_{\text{LC}} < f_{\text{C}} / 3$$

### 8.2.2.9 Output Ripple Voltage Due to Load Transients, $\Delta V_{\text{OUTx}}$

Assume a bandwidth of  $f_{\text{C}} = 10 \text{ kHz}$ .

$$\begin{aligned} \Delta V_{\text{OUTx}} &= R_{\text{ESR}} \times \Delta I_{\text{OUTx}} + \frac{\Delta I_{\text{OUTx}}}{4 \times C_{\text{OUTx}} \times f_{\text{C}}} \\ &= 0.04 \Omega \times 2.5 \text{ A} + \frac{2.5 \text{ A}}{4 \times 660 \mu\text{F} \times 10 \text{ kHz}} = 0.19 \text{ V} \end{aligned} \quad (13)$$

Because the boost converter is active only during brief events such as a cranking pulse, and the buck converters are high-voltage tolerant, a higher excursion on the boost output is tolerable in some cases. In such cases, choose smaller components for the boost output.

### 8.2.2.10 Selection of Components for Type II Compensation

The required loop gain for unity-gain bandwidth (UGB) is

$$G = 40 \log \left( \frac{f_{\text{C}}}{f_{\text{LC}}} \right) - 20 \log \left( \frac{f_{\text{C}}}{f_{\text{ESR}}} \right)$$

$$G = 40 \log \left( \frac{10 \text{ kHz}}{3.1 \text{ kHz}} \right) - 20 \log \left( \frac{10 \text{ kHz}}{6 \text{ kHz}} \right) = 15.9 \text{ dB} \quad (14)$$

The boost-converter error amplifier (OTA) has a  $G_{\text{m}}$  that is proportional to the  $V_{\text{BAT}}$  voltage, which allows a constant loop response across the input-voltage range and makes compensation easier by removing the dependency on  $V_{\text{BAT}}$ .

$$R3 = \frac{10^{G/20}}{85 \times 10^{-6} \text{ A/V}^2 \times V_{\text{OUTx}}} = 7.2 \text{ k}\Omega$$

$$C1 = \frac{10}{2\pi \times f_C \times R3} = \frac{10}{2\pi \times 10 \text{ kHz} \times 7.2 \text{ k}\Omega} = 22 \text{ nF}$$

$$C2 = \frac{C1}{2\pi \times R3 \times C1 \times \left(\frac{f_{\text{SW}}}{2}\right) - 1} = \frac{22 \text{ nF}}{2\pi \times 7.2 \text{ k}\Omega \times 22 \text{ nF} \times \left(\frac{200 \text{ kHz}}{2}\right) - 1} = 223 \text{ pF}$$
(15)

### 8.2.2.11 Input Capacitor, $C_{\text{IN}}$

The input ripple required is lower than 50 mV.

$$\Delta V_{C1} = \frac{I_{\text{RIPPLE}}}{8 \times f_{\text{SW}} \times C_{\text{IN}}} = 10 \text{ mV}$$

$$C_{\text{IN}} = \frac{I_{\text{RIPPLE}}}{8 \times f_{\text{SW}} \times \Delta V_{C1}} = 194 \text{ }\mu\text{F}$$

$$\Delta V_{\text{ESR}} = I_{\text{RIPPLE}} \times R_{\text{ESR}} = 40 \text{ mV}$$
(16)

Therefore, TI recommends 220  $\mu\text{F}$  with 10-m $\Omega$  ESR or a parallel configuration of several capacitors to achieve such ESR-levels.

### 8.2.2.12 Output Schottky Diode $D1$ Selection

Maximizing efficiency requires a Schottky diode with low forward-conducting voltage ( $V_F$ ) over temperature and fast switching characteristics. The reverse breakdown voltage must be higher than the maximum input voltage, and the component must have low reverse leakage current. Additionally, the peak forward current must be higher than the peak inductor current. Equation 17 gives the power dissipation in the Schottky diode:

$$P_D = I_{D(\text{PEAK})} \times V_F \times (1 - D)$$

$$D = 1 - \frac{V_{\text{INMIN}}}{V_{\text{OUT}} + V_F} = 1 - \frac{5 \text{ V}}{10 \text{ V} + 0.6 \text{ V}} = 0.53$$

$$P_D = 7.85 \text{ A} \times 0.6 \text{ V} \times (1 - 0.53) = 2.2 \text{ W}$$
(17)

### 8.2.2.13 Low-Side MOSFET (BOT\_SW3)

$$P_{\text{BOOSTFET}} = (I_{\text{PK}})^2 \times r_{\text{DS(on)}}(1 + \text{TC}) \times D + \left(\frac{V_1 \times I_{\text{PK}}}{2}\right) \times (t_r + t_f) \times f_{\text{SW}}$$

$$P_{\text{BOOSTFET}} = (7.85 \text{ A})^2 \times 0.02 \text{ }\Omega \times (1 + 0.4) \times 0.53 + \left(\frac{V_1 \times I_{\text{PK}}}{2}\right) \times (20 \text{ ns} + 20 \text{ ns}) \times 200 \text{ kHz} = 1.07 \text{ W}$$
(18)

The times  $t_r$  and  $t_f$  denote the rising and falling times of the switching node and relate to the gate-driver strength of the TPS43330A-Q1 and gate Miller capacitance of the MOSFET. The first term,  $t_r$ , denotes the conduction losses, which the low ON-resistance of the MOSFET minimizes. The second term,  $t_f$ , denotes the transition losses which arise due to the full application of the input voltage across the drain-source of the MOSFET as it turns on or off. Transition losses are higher at high output currents and low input voltages (due to the large input peak current), and when the switching time is low.

**NOTE**

The ON-resistance,  $r_{DS(on)}$ , has a positive temperature coefficient, which produces the  $(TC = d \times \Delta T)$  term that signifies the temperature dependence. (Temperature coefficient  $d$  is available as a normalized value from MOSFET data sheets and has an assumed starting value of 0.005 per °C.)

**8.2.2.14 BuckA Component Selection**
**8.2.2.14.1 BuckA Component Selection**

$$t_{ON\min} = \frac{V_{OUTA}}{V_{IN\max} \times f_{SW}} = \frac{3.3\text{ V}}{30\text{ V} \times 400\text{ kHz}} = 275\text{ ns} \quad (19)$$

$t_{ON\min}$  is higher than the minimum duty cycle specified (100 ns typical). Hence, the minimum duty cycle is achievable at this frequency.

**8.2.2.14.2 Current-Sense Resistor  $R_{SENSE}$** 

Based on the typical characteristics for the  $V_{SENSE}$  limit with  $V_{IN}$  versus duty cycle, the sense limit is approximately 65 mV (at  $V_{IN} = 12\text{ V}$  and duty cycle of  $5\text{ V} / 12\text{ V} = 0.416$ ). Allowing for tolerances and ripple currents, choose a  $V_{SENSE}$  maximum of 50 mV.

$$R_{SENSE} = \frac{50\text{ mV}}{3\text{ A}} = 17\text{ m}\Omega \quad (20)$$

Select 15 m $\Omega$ .

**8.2.2.15 Inductor Selection  $L$** 

As explained in the description of the buck controllers, for optimal slope compensation and loop response, choose the inductor such that:

$$L = K_{FLR} \times \frac{R_{SENSE}}{f_{SW}} = 200 \times \frac{15\text{ m}\Omega}{400\text{ kHz}} = 7.5\text{ }\mu\text{H}$$

- $K_{FLR}$  = coil-selection constant = 200 (21)

Choose a standard value of 8.2  $\mu\text{H}$ . For the buck converter, choose the inductor saturation currents and core to sustain the maximum currents.

**8.2.2.16 Inductor Ripple Current  $I_{RIPPLE}$** 

At the nominal input voltage of 12 V, this inductor value causes a ripple current of 30% of  $I_{OUT\max} \approx 1\text{ A}$ .

**8.2.2.17 Output Capacitor  $C_{OUTA}$** 

Select an output capacitance  $C_{OUTA}$  of 100  $\mu\text{F}$  with low ESR in the range of 10 m $\Omega$ , giving  $\Delta V_{OUT(Ripple)} \approx 15\text{ mV}$  and a  $\Delta V$  drop of  $\approx 180\text{ mV}$  during a load step, which does not trigger the power-good comparator and is within the required limits.

$$C_{OUTA} \approx \frac{2 \times \Delta I_{OUTA}}{f_{SW} \times \Delta V_{OUTA}} = \frac{2 \times 2.9\text{ A}}{400\text{ kHz} \times 0.2\text{ V}} = 72.5\text{ }\mu\text{F} \quad (22)$$

$$V_{OUTA(Ripple)} = \frac{I_{OUTA(Ripple)}}{8 \times f_{SW} \times C_{OUTA}} + I_{OUTA(Ripple)} \times ESR = \frac{1\text{ A}}{8 \times 400\text{ kHz} \times 100\text{ }\mu\text{F}} + 1\text{ A} \times 10\text{ m}\Omega = 13.1\text{ mV} \quad (23)$$

$$\Delta V_{OUTA} = \frac{\Delta I_{OUTA}}{4 \times f_C \times C_{OUTA}} + \Delta I_{OUTA} \times ESR = \frac{2.9\text{ A}}{4 \times 50\text{ kHz} \times 100\text{ }\mu\text{F}} + 2.9\text{ A} \times 10\text{ m}\Omega = 174\text{ mV} \quad (24)$$

**8.2.2.18 Bandwidth of Buck Converter  $f_C$** 

Use the following guidelines to set frequency poles, zeroes, and crossover values for the trade-off between stability and transient response.

- Crossover frequency  $f_C$  between  $f_{SW} / 6$  and  $f_{SW} / 10$ . Assume  $f_C = 50$  kHz.
- Select the zero  $f_z \approx f_C / 10$
- Make the second pole  $f_{P2} \approx f_{SW} / 2$

### 8.2.2.19 Selection of Components for Type II Compensation

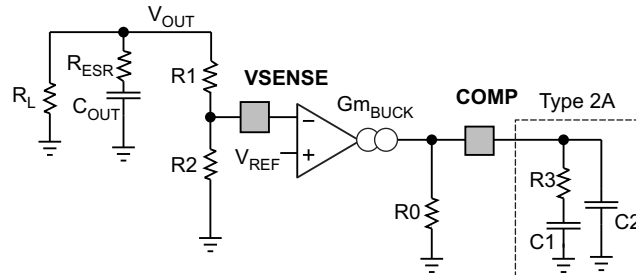

Figure 26. Buck Compensation Components

$$R3 = \frac{2\pi \times f_C \times V_{OUT} \times C_{OUTx}}{Gm_{BUCK} \times K_{CFB} \times V_{REF}} = \frac{2\pi \times 50 \text{ kHz} \times 5 \text{ V} \times 100\mu\text{F}}{Gm_{BUCK} \times K_{CFB} \times V_{REF}} = 23.57 \text{ k}\Omega$$

where

- $V_{OUT} = 5 \text{ V}$
  - $C_{OUT} = 100 \mu\text{F}$
  - $Gm_{BUCK} = 1 \text{ mS}$
  - $V_{REF} = 0.8 \text{ V}$
  - $K_{CFB} = 0.125 / R_{SENSE} = 8.33 \text{ S}$  (0.125 is an internal constant)
- (25)

Use the standard value of  $R3 = 24 \text{ k}\Omega$ .

$$C1 = \frac{10}{2\pi \times R3 \times f_C} = \frac{10}{2\pi \times 24 \text{ k}\Omega \times 50 \text{ kHz}} = 1.33 \text{ nF}$$

(26)

Use the standard value of  $1.5 \text{ nF}$ .

$$C2 = \frac{C1}{2\pi \times R3 \times C1 \left( \frac{f_{SW}}{2} \right) - 1} = \frac{1.5 \text{ nF}}{2\pi \times 24 \text{ k}\Omega \times 1.5 \text{ nF} \left( \frac{400 \text{ kHz}}{2} \right) - 1} = 33 \text{ pF}$$

(27)

The resulting bandwidth of buck converter  $f_C$

$$f_C = \frac{Gm_{BUCK} \times R3 \times K_{CFB}}{2\pi \times C_{OUTx}} \times \frac{V_{REF}}{V_{OUT}}$$

$$f_C = \frac{1 \text{ mS} \times 24 \text{ k}\Omega \times 8.33 \text{ S} \times 0.8 \text{ V}}{2\pi \times 100 \mu\text{F} \times 5 \text{ V}} = 50.9 \text{ kHz}$$

(28)

$f_C$  is close to the target bandwidth of  $50 \text{ kHz}$ .

The resulting zero frequency  $f_{z1}$

$$f_{z1} = \frac{1}{2\pi \times R3 \times C1} = \frac{1}{2\pi \times 24 \text{ k}\Omega \times 1.5 \text{ nF}} = 4.42 \text{ kHz}$$

(29)

$f_{z1}$  is close to the  $f_C / 10$  guideline of  $5 \text{ kHz}$ .

The second pole frequency  $f_{P2}$

$$f_{P2} = \frac{1}{2\pi \times R3 \times C2} = \frac{1}{2\pi \times 24 \text{ k}\Omega \times 33 \text{ pF}} = 201 \text{ kHz}$$

(30)

$f_{P2}$  is close to the  $f_{SW} / 2$  guideline of 200 kHz. Hence, the design satisfies all requirements for a good loop.

### 8.2.2.20 Resistor Divider Selection for Setting $V_{OUTA}$ Voltage

$$\beta = \frac{V_{REF}}{V_{OUTA}} = \frac{0.8 \text{ V}}{5 \text{ V}} = 0.16 \quad (31)$$

Choose the divider current through R1 and R2 to be 50  $\mu\text{A}$ . Then

$$R1 + R2 = \frac{5 \text{ V}}{50 \mu\text{A}} = 100 \text{ k}\Omega \quad (32)$$

and

$$\frac{R2}{R1 + R2} = 0.16 \quad (33)$$

Therefore,  $R2 = 16 \text{ k}\Omega$  and  $R1 = 84 \text{ k}\Omega$ .

### 8.2.2.21 BuckB Component Selection

Using the same method as for  $V_{BUCKA}$  produces the following parameters and components.

$$t_{ONmin} = \frac{V_{OUTB}}{V_{INmax} \times f_{SW}} = \frac{3.3 \text{ V}}{30 \text{ V} \times 400 \text{ kHz}} = 275 \text{ ns} \quad (34)$$

This result is higher than the minimum duty cycle specified (100 ns typical).

$$R_{SENSE} = \frac{60 \text{ mV}}{2 \text{ A}} = 30 \text{ m}\Omega$$

$$L = 200 \times \frac{30 \text{ m}\Omega}{400 \text{ kHz}} = 15 \mu\text{H} \quad (35)$$

$\Delta I_{ripple}$  current  $\approx 0.4 \text{ A}$  (approximately 20% of  $I_{OUTmax}$ )

Select an output capacitance  $C_{OUTB}$  of 100  $\mu\text{F}$  with low ESR in the range of 10  $\text{m}\Omega$ .

Assume  $f_C = 50 \text{ kHz}$ .

$$C_{OUTB} \approx \frac{2 \times \Delta I_{OUTB}}{f_{SW} \times \Delta V_{OUTB}} = \frac{2 \times 1.9 \text{ A}}{400 \text{ kHz} \times 0.12 \text{ V}} = 46 \mu\text{F} \quad (36)$$

$$V_{OUTB(Ripple)} = \frac{I_{OUTB(Ripple)}}{8 \times f_{SW} \times C_{OUTB}} + I_{OUTB(Ripple)} \times ESR = \frac{0.4 \text{ A}}{8 \times 400 \text{ kHz} \times 100 \mu\text{F}} + 0.4 \text{ A} \times 10 \text{ m}\Omega = 5.3 \text{ mV} \quad (37)$$

$$\Delta V_{OUTB} = \frac{\Delta I_{OUTB}}{4 \times f_C \times C_{OUTB}} + \Delta I_{OUTB} \times ESR = \frac{1.9 \text{ A}}{4 \times 50 \text{ kHz} \times 100 \mu\text{F}} + 1.9 \text{ A} \times 10 \text{ m}\Omega = 114 \text{ mV} \quad (38)$$

$$R3 = \frac{2\pi \times f_C \times V_{OUTB} \times C_{OUTB}}{Gm_{BUCK} \times K_{CFB} \times V_{REF}}$$

$$= \frac{2\pi \times 50 \text{ kHz} \times 3.3 \text{ V} \times 100 \mu\text{F}}{1 \text{ mS} \times 4.16 \text{ S} \times 0.8 \text{ V}} = 31 \text{ k}\Omega \quad (39)$$

Use the standard value of  $R3 = 30 \text{ k}\Omega$ .

$$C1 = \frac{10}{2\pi \times R3 \times f_C} = \frac{10}{2\pi \times 30 \text{ k}\Omega \times 50 \text{ kHz}} = 1.1 \text{ nF} \quad (40)$$

$$\begin{aligned}
 C2 &= \frac{C1}{2\pi \times R3 \times C1 \times \left(\frac{f_{SW}}{2}\right) - 1} \\
 &= \frac{1.1 \text{ nF}}{2\pi \times 30 \text{ k}\Omega \times 1.1 \text{ nF} \times \left(\frac{400 \text{ kHz}}{2}\right) - 1} = 27 \text{ pF}
 \end{aligned} \tag{41}$$

$$\begin{aligned}
 f_C &= \frac{Gm_{BUCK} \times R3 \times K_{CFB} \times V_{REF}}{2\pi \times C_{OUTB}} \times \frac{V_{REF}}{V_{OUTB}} \\
 &= \frac{1 \text{ mS} \times 30 \text{ k}\Omega \times 4.16 \text{ S} \times 0.8 \text{ V}}{2\pi \times 100 \text{ }\mu\text{F} \times 3.3 \text{ V}} = 48 \text{ kHz}
 \end{aligned} \tag{42}$$

$f_C$  is close to the target bandwidth of 50 kHz.

#### The resulting zero frequency $f_{z1}$

$$f_{z1} = \frac{1}{2\pi \times R3 \times C1} = \frac{1}{2\pi \times 30 \text{ k}\Omega \times 1.1 \text{ nF}} = 4.8 \text{ kHz} \tag{43}$$

$f_{z1}$  is close to the  $f_C$  guideline of 5 kHz.

#### The second pole frequency $f_{p2}$

$$f_{p2} = \frac{1}{2\pi \times R3 \times C2} = \frac{1}{2\pi \times 30 \text{ k}\Omega \times 27 \text{ pF}} = 196 \text{ kHz} \tag{44}$$

$f_{p2}$  is close to the  $f_{SW} / 2$  guideline of 200 kHz.

Hence, the design satisfies all requirements for a good loop.

#### 8.2.2.2 Resistor Divider Selection for Setting $V_{OUT}$ Voltage

$$\beta = \frac{V_{REF}}{V_{OUT}} = \frac{0.8 \text{ V}}{3.3 \text{ V}} = 0.242 \tag{45}$$

Choose the divider current through R1 and R2 to be 50  $\mu\text{A}$ . Then

$$R1 + R2 = \frac{3.3 \text{ V}}{50 \text{ }\mu\text{A}} = 66 \text{ k}\Omega \tag{46}$$

and

$$\frac{R2}{R1 + R2} = 0.242 \tag{47}$$

Therefore,  $R2 = 16 \text{ k}\Omega$  and  $R1 = 50 \text{ k}\Omega$ .

#### 8.2.2.3 BuckX High-Side and Low-Side N-Channel MOSFETs

An internal supply, which is 5.8 V typical under normal operating conditions, provides the gate-drive supply for these MOSFETs. The output is a totem pole, allowing full-voltage drive of  $V_{REG}$  to the gate with peak output current of 1.5 A. The reference for the high-side MOSFET is a floating node at the phase terminal (PHx), and the reference for the low-side MOSFET is the power-ground (PGNDx) terminal. For a particular application, select these MOSFETs with consideration for the following parameters:  $r_{DS(on)}$ , gate charge  $Q_g$ , drain-to-source breakdown voltage  $BVDSS$ , maximum DC current  $IDC(max)$ , and thermal resistance for the package.

The times  $t_r$  and  $t_f$  denote the rising and falling times of the switching node and have a relationship to the gate-driver strength of the TPS43330A-Q1 and to the gate Miller capacitance of the MOSFET. The first term,  $t_r$ , denotes the conduction losses, which are minimal when the ON-resistance of the MOSFET is low. The second term,  $t_f$ , denotes the transition losses, which arise due to the full application of the input voltage across the drain-source of the MOSFET as it turns on or off. Transition losses are lower at low currents and when the switching time is low.

$$P_{\text{BuckTOPFET}} = (I_{\text{OUT}})^2 \times r_{\text{DS(on)}}(1 + \text{TC}) \times D + \left( \frac{V_{\text{IN}} \times I_{\text{OUT}}}{2} \right) \times (t_r + t_f) \times f_{\text{SW}} \tag{48}$$

$$P_{\text{BuckLOWERFET}} = (I_{\text{OUT}})^2 \times r_{\text{DS(on)}}(1 + \text{TC}) \times (1 - D) + V_F \times I_{\text{OUT}} \times (2 \times t_d) \times f_{\text{SW}} \tag{49}$$

In addition, during the dead time ( $t_d$ ) when both the MOSFETs are off, the body diode of the low-side MOSFET conducts, increasing the losses. The second term in Equation 49 denotes this dead time. Using external Schottky diodes in parallel with the low-side MOSFETs of the buck converters helps to reduce this loss.

**NOTE**

$r_{\text{DS(on)}}$  has a positive temperature coefficient, and the TC term for  $r_{\text{DS(on)}}$  accounts for that fact.  $\text{TC} = d \times \Delta T[^\circ\text{C}]$ . The temperature coefficient  $d$  is available as a normalized value from MOSFET data sheets and has an assumed starting value of 0.005 per  $^\circ\text{C}$ .

**8.2.3 Application Curves**

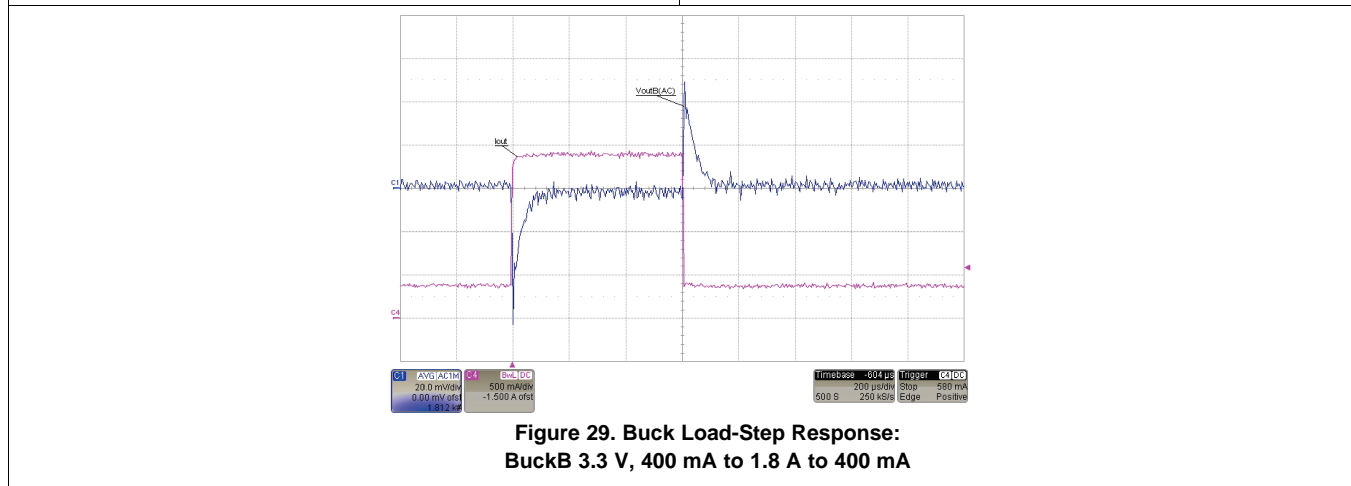
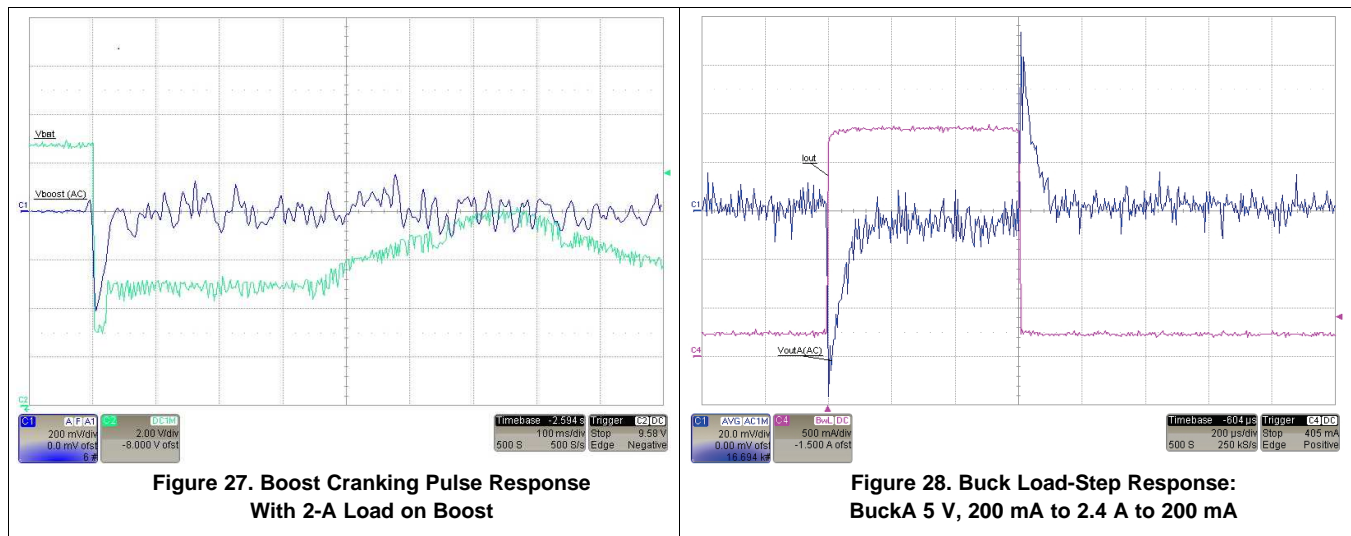

### 8.3 System Examples

The following section summarizes the previously calculated example and gives schematic and component proposals.

#### 8.3.1 Example 1

The following example shows an application with Buck A supplying 5 V at 3 A and BuckB set to 3.3 V at 2 A. Boost-output is set to 10 V.

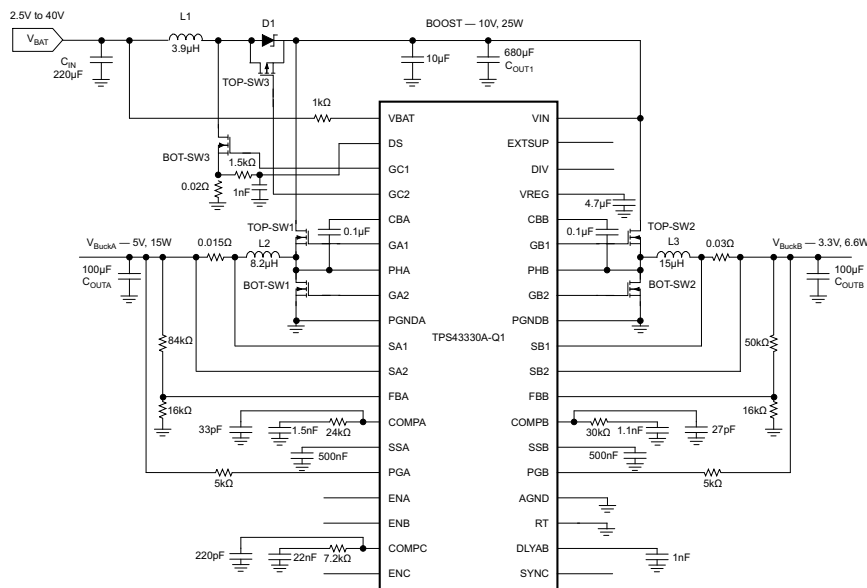

Copyright © 2016, Texas Instruments Incorporated

Figure 30. Simplified Application Schematic, Example 1

Table 5. Application Example 1

PARAMETER	V <sub>BuckA</sub>	V <sub>BuckB</sub>	BOOST
Input voltage	V <sub>IN</sub> = 6 V to 30 V 12 V - typical	V <sub>IN</sub> = 6 V to 30 V 12 V - typical	V <sub>BAT</sub> = 5 V (cranking pulse input) to 30 V
Output voltage, V <sub>OUTx</sub>	5 V	3.3 V	10 V
Maximum output current, I <sub>OUTx</sub>	3 A	2 A	2.5 A
Load-step output tolerance, ΔV <sub>OUT</sub> + ΔV <sub>OUT(Ripple)</sub>	±0.2 V	±0.12 V	±0.5 V
Current output load-step, ΔI <sub>OUTx</sub>	0.1 to 3 A	0.1 to 2 A	0.1 to 2.5 A
Converter switching frequency, f <sub>SW</sub>	400 kHz	400 kHz	200 kHz

Table 6. Application Example 1 – Component Proposals

NAME	COMPONENT PROPOSAL	VALUE
L1	MSS1278T-392NL (Coilcraft)	3.9 µH
L2	MSS1278T-822ML (Coilcraft)	8.2 µH
L3	MSS1278T-153ML (Coilcraft)	15 µH
D1	SK103 (Micro Commercial Components)	
TOP_SW3	IRF7416 (International Rectifier)	
TOP_SW1, TOP_SW2	Si4840DY-T1-E3 (Vishay)	
BOT_SW1, BOT_SW2	Si4840DY-T1-E3 (Vishay)	
BOT_SW3	IRFR3504ZTRPBF (International Rectifier)	
C <sub>OUT1</sub>	EEVFK1J681M (Panasonic)	680 µF
C <sub>OUTA</sub> , C <sub>OUTB</sub>	ECASD91A107M010K00 (Murata)	100 µF
C <sub>IN</sub>	EEEFK1V331P (Panasonic)	220 µF

### 8.3.2 Example 2

The following example shows an application with lower output voltage and reduced load on BuckB (2.5 V, 1 A).

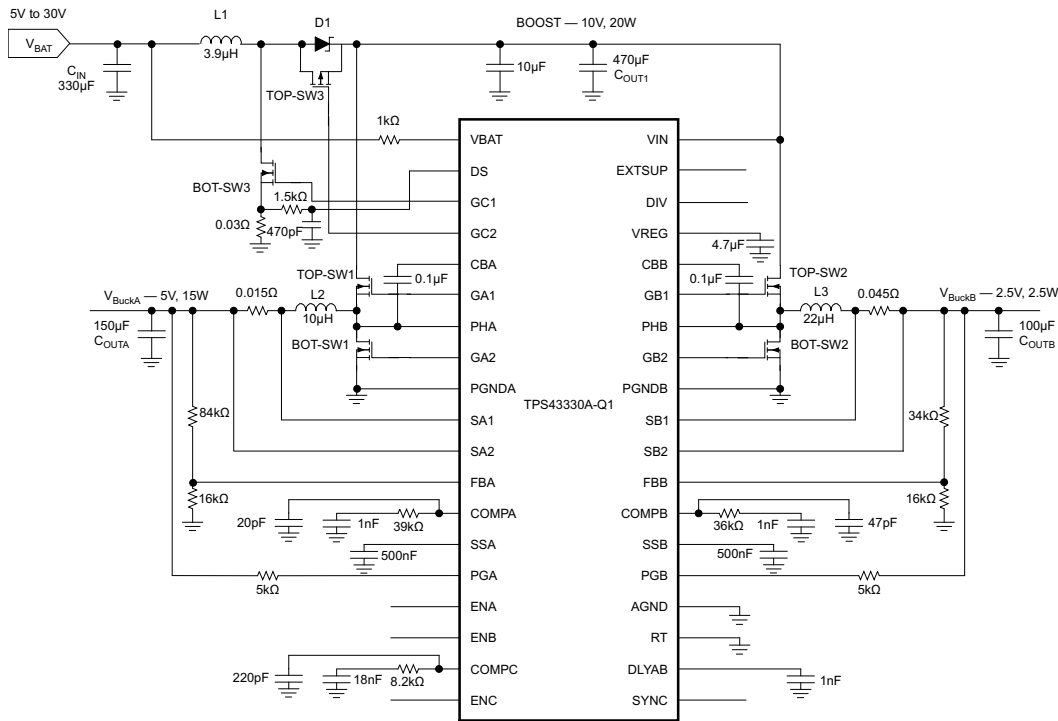

Copyright © 2016, Texas Instruments Incorporated

Figure 31. Simplified Application Schematic, Example 2

Table 7. Application Example 2

PARAMETER	V <sub>BuckA</sub>	V <sub>BuckB</sub>	BOOST
Input voltage	V <sub>IN</sub> = 5 V to 30 V 12 V - typical	V <sub>IN</sub> = 6 V to 30 V 12 V - typical	V <sub>BAT</sub> = 5 V (cranking pulse input) to 30 V
Output voltage, V <sub>OUTx</sub>	5 V	2.5 V	10 V
Maximum output current, I <sub>OUTx</sub>	3 A	1 A	2 A
Load-step output tolerance, ΔV <sub>OUT</sub> + ΔV <sub>OUT(Ripple)</sub>	±0.2 V	±0.12 V	±0.5 V
Current output load-step, ΔI <sub>OUTx</sub>	0.1 to 3 A	0.1 to 1 A	0.1 to 2 A
Converter switching frequency, f <sub>SW</sub>	400 kHz	400 kHz	200 kHz

Table 8. Application Example 2 – Component Proposals

NAME	COMPONENT PROPOSAL	VALUE
L1	MSS1278T-392NL (Coilcraft)	3.9 µH
L2	MSS1278T-822ML (Coilcraft)	8.2 µH
L3	MSS1278T-223ML (Coilcraft)	22 µH
D1	SK103 (Micro Commercial Components)	
TOP_SW3	IRF7416 (International Rectifier)	
TOP_SW1, TOP_SW2	Si4840DY-T1-E3 (Vishay)	
BOT_SW1, BOT_SW2	Si4840DY-T1-E3 (Vishay)	
BOT_SW3	IRFR3504ZTRPBF (International Rectifier)	
C <sub>OUT1</sub>	EEVFK1V471Q (Panasonic)	470 µF
C <sub>OUTA</sub>	ECASD91A157M010K00 (Murata)	150 µF
C <sub>OUTB</sub>	ECASD40J107M015K00 (Murata)	100 µF

**Table 8. Application Example 2 – Component Proposals (continued)**

NAME	COMPONENT PROPOSAL	VALUE
C <sub>IN</sub>	EEEFK1V331P (Panasonic)	330 μF

## 9 Power Supply Recommendations

The TPS43330A-Q1 is designed to operate from an input voltage up to 40 V. Ensure that the input supply is well regulated. Furthermore, if the supply voltage in the application is likely to reach negative voltage (for example, reverse battery) a forward diode must be placed at the input of the supply. For the VIN pin, a good-quality X7R ceramic capacitor is recommended. Capacitance derating for aging, temperature, and DC bias must be considered while determining the capacitor value. Connect a local decoupling capacitor close to the Vreg for proper filtering. The PowerPAD package, which offers an exposed thermal pad to enhance thermal performance, must be soldered to the copper landing on the PCB for optimal performance.

## 10 Layout

### 10.1 Layout Guidelines

#### 10.1.1 Boost Converter

1. The path formed from the input capacitor to the inductor and BOT\_SW3 with the low-side current-sense resistor must have short leads and PC trace lengths. The same applies for the trace from the inductor to Schottky diode D1 to the C<sub>OUT1</sub> capacitor. Connect the negative terminal of the input capacitor and the negative terminal of the sense resistor together with short trace lengths.
2. The overcurrent-sensing shunt resistor requires noise filtering, and the filter capacitor must be close to the IC pin.

#### 10.1.2 Buck Converter

1. Connect the drain of TOP\_SW1 and TOP\_SW2 together with the positive terminal of input capacitor C<sub>OUT1</sub>. The trace length between these terminals must be short.
2. Connect a local decoupling capacitor between the drain of TOP\_SWx and the source of BOT\_SWx.
3. The Kelvin-current sensing for the shunt resistor has traces with minimum spacing, routed in parallel with each other. Place any filtering capacitors for noise near the IC pins.
4. The resistor divider for sensing the output voltage connects between the positive terminal of either respective output capacitor and C<sub>OUTA</sub> or C<sub>OUTB</sub> and the IC signal ground. Do not locate these components and their traces near any switching nodes or high-current traces.

#### 10.1.3 Other Considerations

1. Short PGNDx and AGND to the thermal pad. Use a star-ground configuration if connecting to a non-ground plane system. Use tie-ins for the EXTSUP capacitor, compensation-network ground, and voltage-sense feedback ground networks to this star ground.
2. Connect a compensation network between the compensation pins and IC signal ground. Connect the oscillator resistor (frequency setting) between the RT pin and IC signal ground. These sensitive circuits must not be located near nodes showing high dv/dt; these include the gate-drive outputs, phase pins, and boost circuits (bootstrap).
3. Reduce the surface area of the high-current-carrying loops to a minimum by ensuring optimal component placement. Locate the bypass capacitors as close as possible to the respective power and ground pins.

## 10.2 Layout Example

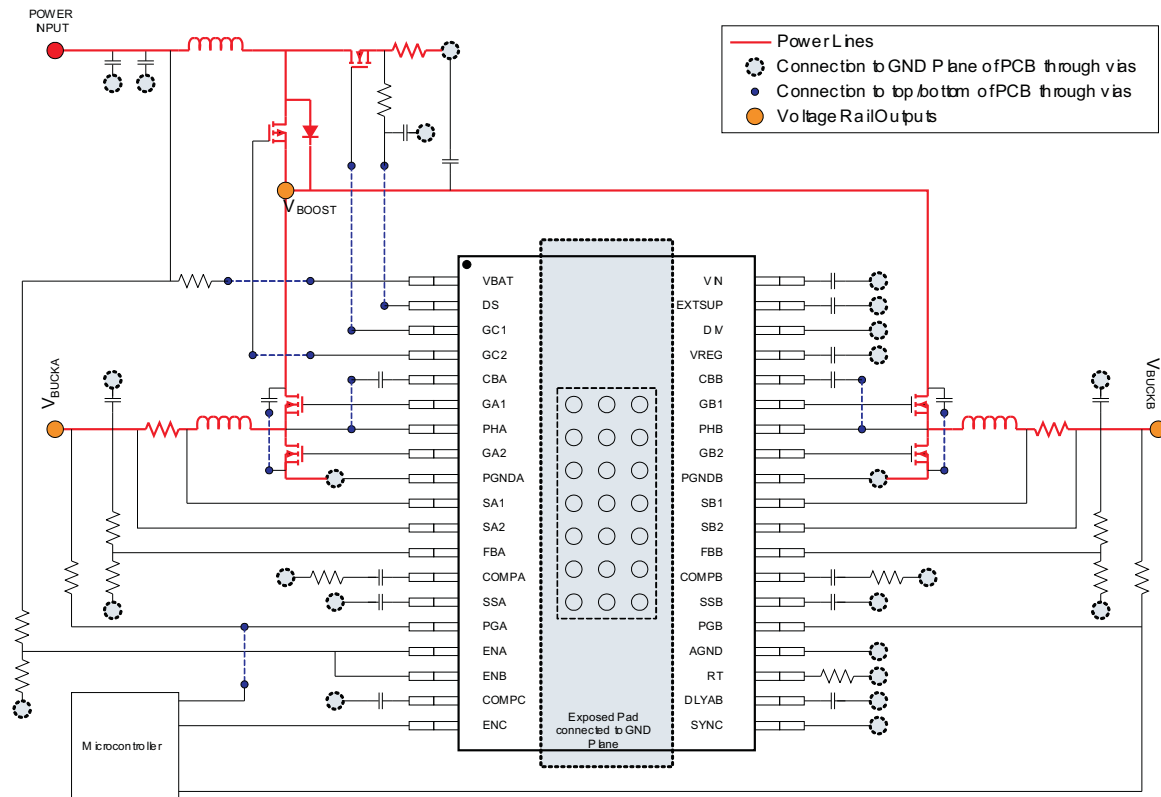

Figure 32. Layout Guidelines Highlighting Critical Paths

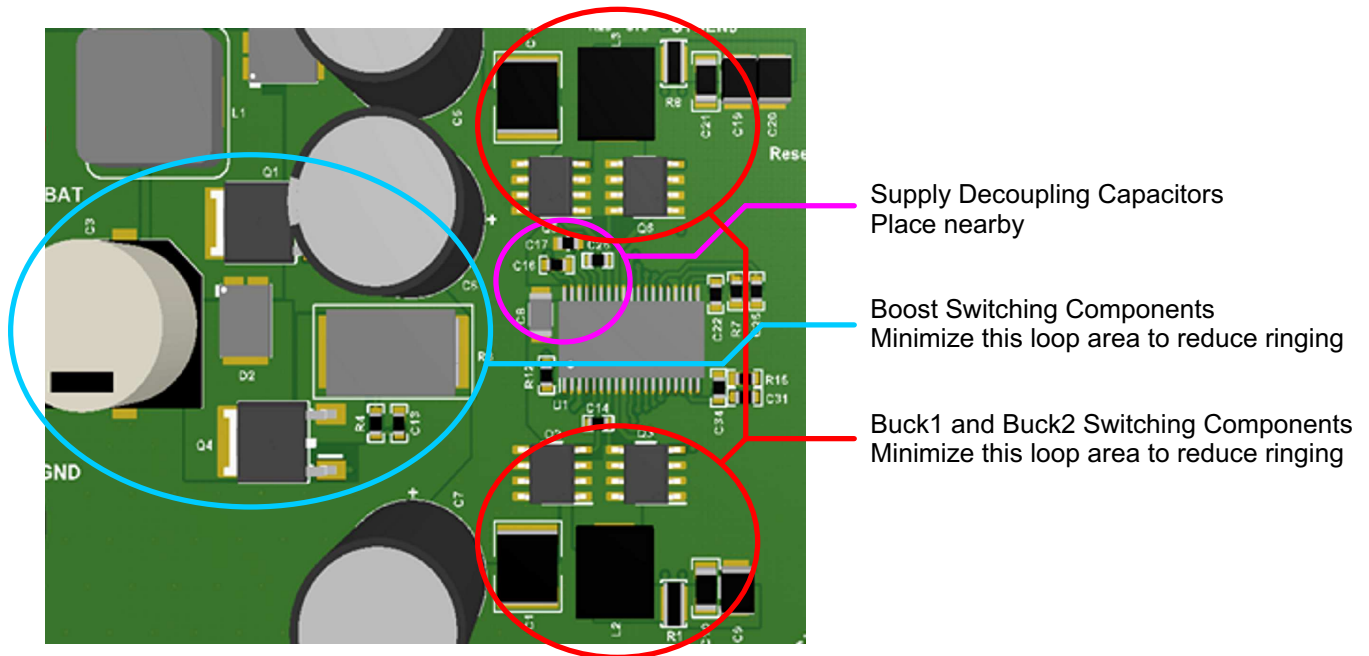

Figure 33. Layout Example and Recommendations

### 10.3 Power Dissipation Derating Profile, 38-Pin HTTSOP PowerPAD™ Package

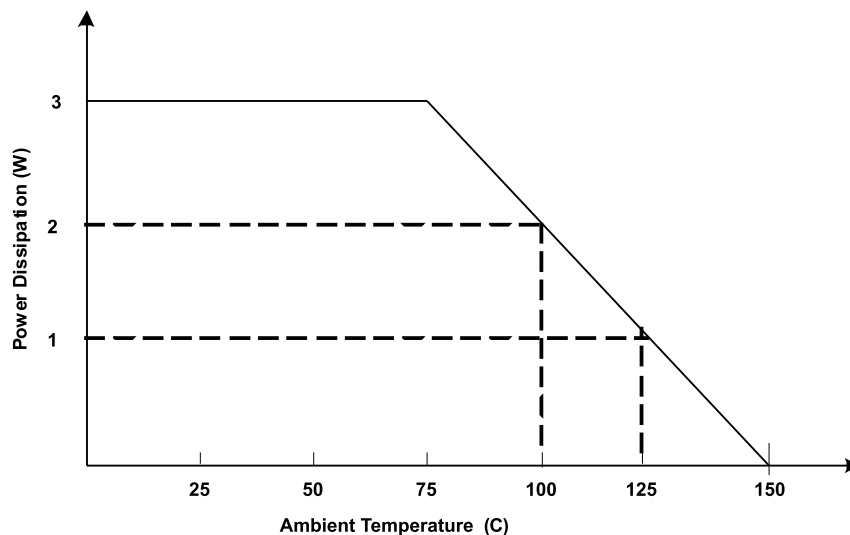

Figure 34. Derating Profile for Power Dissipation Based on High-K JEDEC PCB

## 11 Device and Documentation Support

### 11.1 Receiving Notification of Documentation Updates

To receive notification of documentation updates, navigate to the device product folder on ti.com. In the upper right corner, click on *Alert me* to register and receive a weekly digest of any product information that has changed. For change details, review the revision history included in any revised document.

### 11.2 Community Resources

The following links connect to TI community resources. Linked contents are provided "AS IS" by the respective contributors. They do not constitute TI specifications and do not necessarily reflect TI's views; see TI's [Terms of Use](#).

**TI E2E™ Online Community** *TI's Engineer-to-Engineer (E2E) Community*. Created to foster collaboration among engineers. At e2e.ti.com, you can ask questions, share knowledge, explore ideas and help solve problems with fellow engineers.

**Design Support** *TI's Design Support* Quickly find helpful E2E forums along with design support tools and contact information for technical support.

### 11.3 Trademarks

PowerPAD, E2E are trademarks of Texas Instruments.  
All other trademarks are the property of their respective owners.

### 11.4 Electrostatic Discharge Caution



These devices have limited built-in ESD protection. The leads should be shorted together or the device placed in conductive foam during storage or handling to prevent electrostatic damage to the MOS gates.

### 11.5 Glossary

[SLYZ022](#) — *TI Glossary*.

This glossary lists and explains terms, acronyms, and definitions.

## 12 Mechanical, Packaging, and Orderable Information

The following pages include mechanical, packaging, and orderable information. This information is the most current data available for the designated devices. This data is subject to change without notice and revision of this document. For browser-based versions of this data sheet, refer to the left-hand navigation.

**PACKAGING INFORMATION**

Orderable Device	Status (1)	Package Type	Package Drawing	Pins	Package Qty	Eco Plan (2)	Lead/Ball Finish (6)	MSL Peak Temp (3)	Op Temp (°C)	Device Marking (4/5)	Samples
TPS43330AQDAPRQ1	ACTIVE	HTSSOP	DAP	38	2000	Green (RoHS & no Sb/Br)	CU NIPDAU	Level-3-260C-168 HR	-40 to 125	TPS43330A	<b>Samples</b>

(1) The marketing status values are defined as follows:

**ACTIVE:** Product device recommended for new designs.

**LIFEBUY:** TI has announced that the device will be discontinued, and a lifetime-buy period is in effect.

**NRND:** Not recommended for new designs. Device is in production to support existing customers, but TI does not recommend using this part in a new design.

**PREVIEW:** Device has been announced but is not in production. Samples may or may not be available.

**OBSELETE:** TI has discontinued the production of the device.

(2) Eco Plan - The planned eco-friendly classification: Pb-Free (RoHS), Pb-Free (RoHS Exempt), or Green (RoHS & no Sb/Br) - please check <http://www.ti.com/productcontent> for the latest availability information and additional product content details.

**TBD:** The Pb-Free/Green conversion plan has not been defined.

**Pb-Free (RoHS):** TI's terms "Lead-Free" or "Pb-Free" mean semiconductor products that are compatible with the current RoHS requirements for all 6 substances, including the requirement that lead not exceed 0.1% by weight in homogeneous materials. Where designed to be soldered at high temperatures, TI Pb-Free products are suitable for use in specified lead-free processes.

**Pb-Free (RoHS Exempt):** This component has a RoHS exemption for either 1) lead-based flip-chip solder bumps used between the die and package, or 2) lead-based die adhesive used between the die and leadframe. The component is otherwise considered Pb-Free (RoHS compatible) as defined above.

**Green (RoHS & no Sb/Br):** TI defines "Green" to mean Pb-Free (RoHS compatible), and free of Bromine (Br) and Antimony (Sb) based flame retardants (Br or Sb do not exceed 0.1% by weight in homogeneous material)

(3) MSL, Peak Temp. - The Moisture Sensitivity Level rating according to the JEDEC industry standard classifications, and peak solder temperature.

(4) There may be additional marking, which relates to the logo, the lot trace code information, or the environmental category on the device.

(5) Multiple Device Markings will be inside parentheses. Only one Device Marking contained in parentheses and separated by a "~" will appear on a device. If a line is indented then it is a continuation of the previous line and the two combined represent the entire Device Marking for that device.

(6) Lead/Ball Finish - Orderable Devices may have multiple material finish options. Finish options are separated by a vertical ruled line. Lead/Ball Finish values may wrap to two lines if the finish value exceeds the maximum column width.

**Important Information and Disclaimer:**The information provided on this page represents TI's knowledge and belief as of the date that it is provided. TI bases its knowledge and belief on information provided by third parties, and makes no representation or warranty as to the accuracy of such information. Efforts are underway to better integrate information from third parties. TI has taken and continues to take reasonable steps to provide representative and accurate information but may not have conducted destructive testing or chemical analysis on incoming materials and chemicals. TI and TI suppliers consider certain information to be proprietary, and thus CAS numbers and other limited information may not be available for release.

In no event shall TI's liability arising out of such information exceed the total purchase price of the TI part(s) at issue in this document sold by TI to Customer on an annual basis.



## TAPE AND REEL INFORMATION



### QUADRANT ASSIGNMENTS FOR PIN 1 ORIENTATION IN TAPE



\*All dimensions are nominal

Device	Package Type	Package Drawing	Pins	SPQ	Reel Diameter (mm)	Reel Width W1 (mm)	A0 (mm)	B0 (mm)	K0 (mm)	P1 (mm)	W (mm)	Pin1 Quadrant
TPS43330AQDAPRQ1	HTSSOP	DAP	38	2000	330.0	24.4	8.6	13.0	1.8	12.0	24.0	Q1

TAPE AND REEL BOX DIMENSIONS

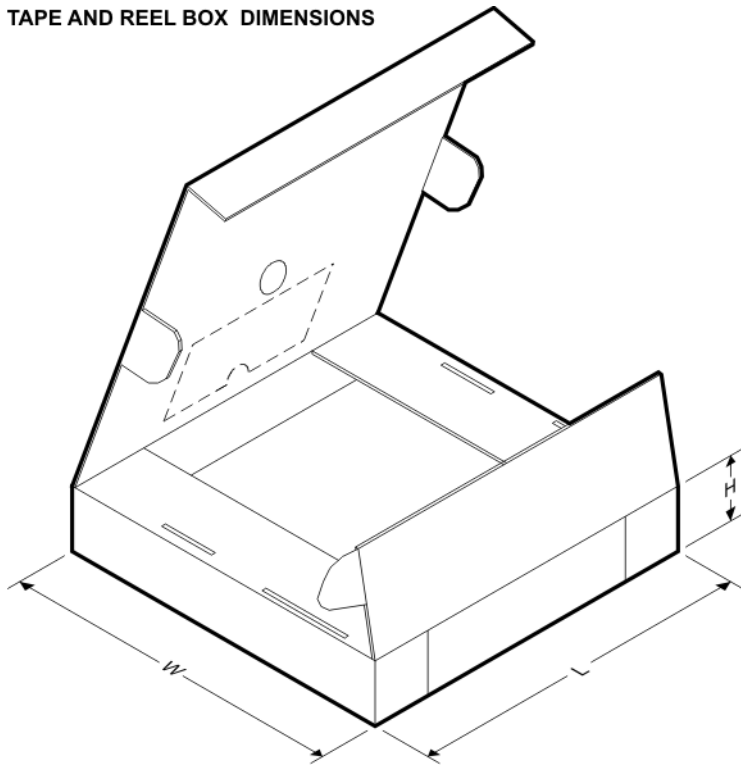

\*All dimensions are nominal

Device	Package Type	Package Drawing	Pins	SPQ	Length (mm)	Width (mm)	Height (mm)
TPS43330AQDAPRQ1	HTSSOP	DAP	38	2000	350.0	350.0	43.0

# MECHANICAL DATA

DAP (R-PDSO-G38) PowerPAD™ PLASTIC SMALL-OUTLINE PACKAGE

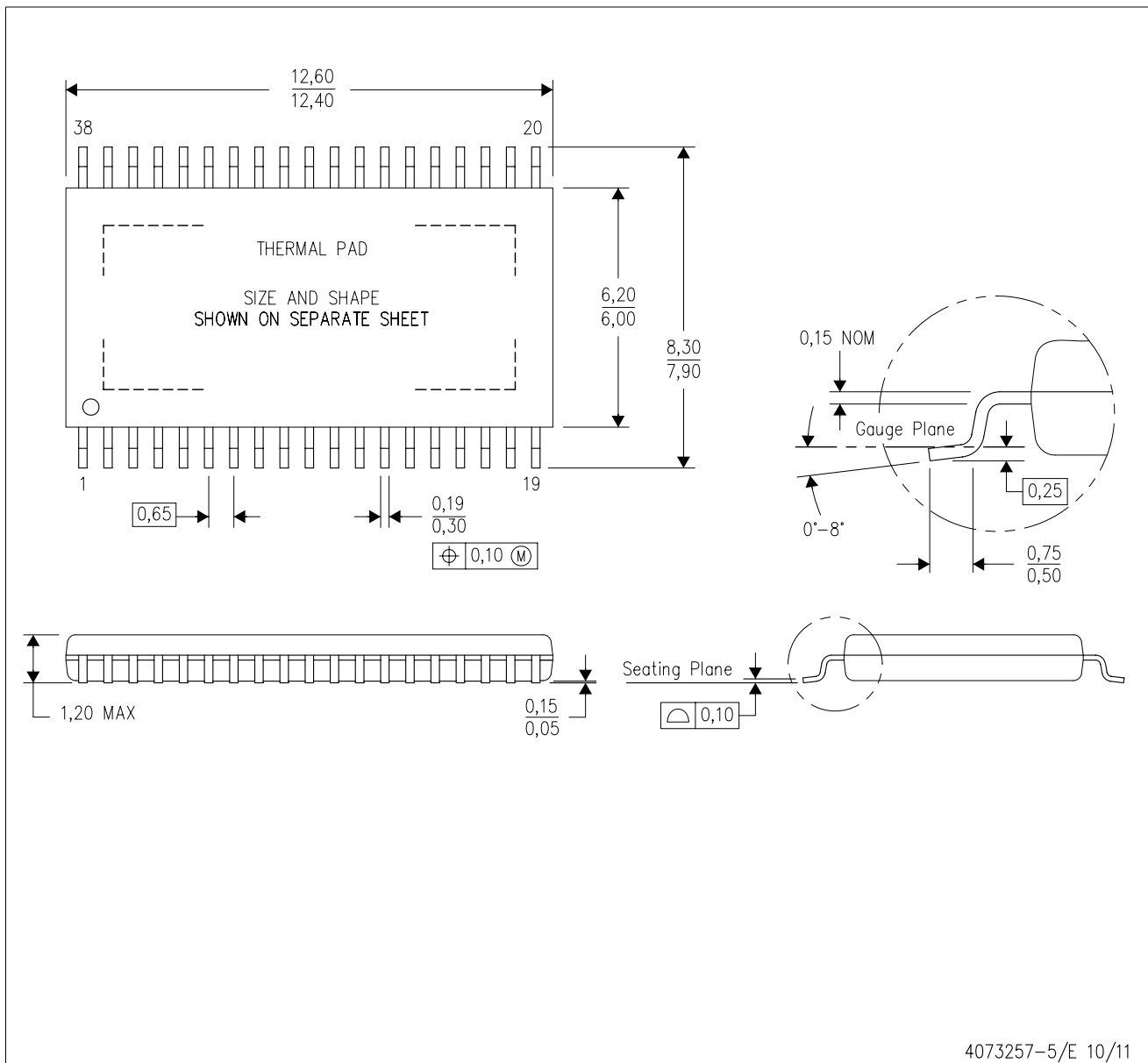

4073257-5/E 10/11

- NOTES:
- A. All linear dimensions are in millimeters.
  - B. This drawing is subject to change without notice.
  - C. Body dimensions do not include mold flash or protrusion. Mold flash and protrusion shall not exceed 0.15 per side.
  - D. This package is designed to be soldered to a thermal pad on the board. Refer to Technical Brief, PowerPad Thermally Enhanced Package, Texas Instruments Literature No. SLMA002 for information regarding recommended board layout. This document is available at [www.ti.com](http://www.ti.com) <<http://www.ti.com>>.
  - E. See the additional figure in the Product Data Sheet for details regarding the exposed thermal pad features and dimensions.
- ⚠ Falls within JEDEC MO-153 Variation DDT-1.

PowerPAD is a trademark of Texas Instruments.

# THERMAL PAD MECHANICAL DATA

DAP (R-PDSO-G38)

PowerPAD™ PLASTIC SMALL OUTLINE

## THERMAL INFORMATION

This PowerPAD™ package incorporates an exposed thermal pad that is designed to be attached to a printed circuit board (PCB). The thermal pad must be soldered directly to the PCB. After soldering, the PCB can be used as a heatsink. In addition, through the use of thermal vias, the thermal pad can be attached directly to the appropriate copper plane shown in the electrical schematic for the device, or alternatively, can be attached to a special heatsink structure designed into the PCB. This design optimizes the heat transfer from the integrated circuit (IC).

For additional information on the PowerPAD package and how to take advantage of its heat dissipating abilities, refer to Technical Brief, PowerPAD Thermally Enhanced Package, Texas Instruments Literature No. SLMA002 and Application Brief, PowerPAD Made Easy, Texas Instruments Literature No. SLMA004. Both documents are available at [www.ti.com](http://www.ti.com).

The exposed thermal pad dimensions for this package are shown in the following illustration.

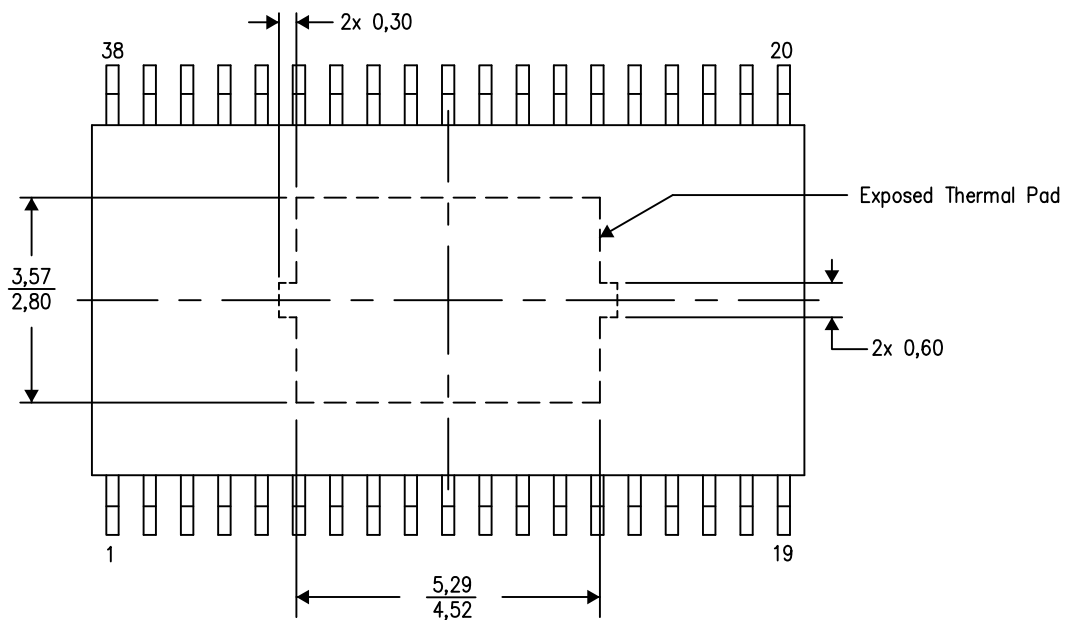

Top View

Exposed Thermal Pad Dimensions

4206319-9/M 09/13

NOTE: All linear dimensions are in millimeters

PowerPAD is a trademark of Texas Instruments.

# LAND PATTERN DATA

## DAP (R-PDSO-G38) PowerPAD™ PLASTIC SMALL OUTLINE PACKAGE

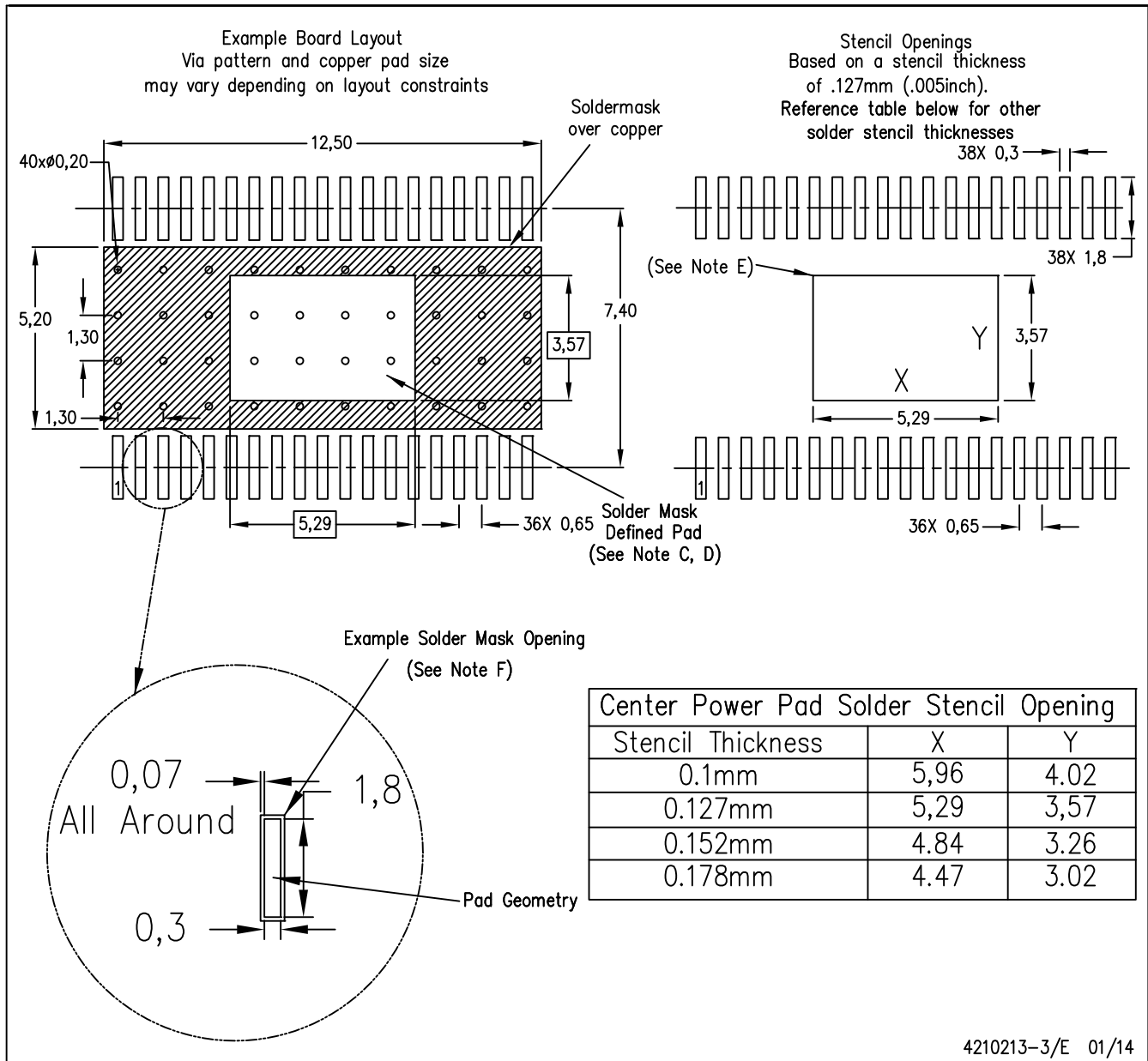

- NOTES:
- All linear dimensions are in millimeters.
  - This drawing is subject to change without notice.
  - Customers should place a note on the circuit board fabrication drawing not to alter the center solder mask defined pad.
  - This package is designed to be soldered to a thermal pad on the board. Refer to Technical Brief, PowerPad Thermally Enhanced Package, Texas Instruments Literature No. SLMA002, SLMA004, and also the Product Data Sheets for specific thermal information, via requirements, and recommended board layout. These documents are available at [www.ti.com](http://www.ti.com) <<http://www.ti.com>>. Publication IPC-7351 is recommended for alternate designs.
  - Laser cutting apertures with trapezoidal walls and also rounding corners will offer better paste release. Customers should contact their board assembly site for stencil design recommendations. Refer to IPC-7525 for other stencil recommendations.
  - Contact the board fabrication site for recommended soldermask tolerances.

PowerPAD is a trademark of Texas Instruments

## IMPORTANT NOTICE AND DISCLAIMER

TI PROVIDES TECHNICAL AND RELIABILITY DATA (INCLUDING DATASHEETS), DESIGN RESOURCES (INCLUDING REFERENCE DESIGNS), APPLICATION OR OTHER DESIGN ADVICE, WEB TOOLS, SAFETY INFORMATION, AND OTHER RESOURCES "AS IS" AND WITH ALL FAULTS, AND DISCLAIMS ALL WARRANTIES, EXPRESS AND IMPLIED, INCLUDING WITHOUT LIMITATION ANY IMPLIED WARRANTIES OF MERCHANTABILITY, FITNESS FOR A PARTICULAR PURPOSE OR NON-INFRINGEMENT OF THIRD PARTY INTELLECTUAL PROPERTY RIGHTS.

These resources are intended for skilled developers designing with TI products. You are solely responsible for (1) selecting the appropriate TI products for your application, (2) designing, validating and testing your application, and (3) ensuring your application meets applicable standards, and any other safety, security, or other requirements. These resources are subject to change without notice. TI grants you permission to use these resources only for development of an application that uses the TI products described in the resource. Other reproduction and display of these resources is prohibited. No license is granted to any other TI intellectual property right or to any third party intellectual property right. TI disclaims responsibility for, and you will fully indemnify TI and its representatives against, any claims, damages, costs, losses, and liabilities arising out of your use of these resources.

TI's products are provided subject to TI's Terms of Sale ([www.ti.com/legal/termsofsale.html](http://www.ti.com/legal/termsofsale.html)) or other applicable terms available either on [ti.com](http://ti.com) or provided in conjunction with such TI products. TI's provision of these resources does not expand or otherwise alter TI's applicable warranties or warranty disclaimers for TI products.

Mailing Address: Texas Instruments, Post Office Box 655303, Dallas, Texas 75265  
Copyright © 2019, Texas Instruments Incorporated

## Looking for pricing, stock, or lifecycle information?

Click below to explore more details on WIN SOURCE:

 [View TPS43330AQDAPRQ1 on WIN SOURCE](#)

 [Texas Instruments](#) Information

## Optimize Your Supply Chain with WIN SOURCE Solutions

-  Global Sourcing Solution
-  Obsolete Management
-  Cost Control Management
-  Shortage Management
-  Alternative Solution
-  Excess Inventory Management