



**THE DATASHEET OF  
LM324M/NOPB**



## LMx24-N, LM2902-N Low-Power, Quad-Operational Amplifiers

### 1 Features

- Internally Frequency Compensated for Unity Gain
- Large DC Voltage Gain 100 dB
- Wide Bandwidth (Unity Gain) 1 MHz (Temperature Compensated)
- Wide Power Supply Range:
  - Single Supply 3 V to 32 V
  - or Dual Supplies  $\pm 1.5$  V to  $\pm 16$  V
- Very Low Supply Current Drain (700  $\mu$ A) —Essentially Independent of Supply Voltage
- Low Input Biasing Current 45 nA (Temperature Compensated)
- Low Input Offset Voltage 2 mV and Offset Current: 5 nA
- Input Common-Mode Voltage Range Includes Ground
- Differential Input Voltage Range Equal to the Power Supply Voltage
- Large Output Voltage Swing 0 V to  $V^+ - 1.5$  V
- **Advantages:**
  - Eliminates Need for Dual Supplies
  - Four Internally Compensated Op Amps in a Single Package
  - Allows Direct Sensing Near GND and  $V_{OUT}$  also Goes to GND
  - Compatible With All Forms of Logic
  - Power Drain Suitable for Battery Operation
  - In the Linear Mode the Input Common-Mode, Voltage Range Includes Ground and the Output Voltage
  - Can Swing to Ground, Even Though Operated from Only a Single Power Supply Voltage
  - Unity Gain Cross Frequency is Temperature Compensated
  - Input Bias Current is Also Temperature Compensated

### 2 Applications

- Transducer Amplifiers
- DC Gain Blocks
- Conventional Op Amp Circuits

### 3 Description

The LM124-N series consists of four independent, high-gain, internally frequency compensated operational amplifiers designed to operate from a single power supply over a wide range of voltages. Operation from split-power supplies is also possible and the low-power supply current drain is independent of the magnitude of the power supply voltage.

Application areas include transducer amplifiers, DC gain blocks and all the conventional op amp circuits which now can be more easily implemented in single power supply systems. For example, the LM124-N series can directly operate off of the standard 5-V power supply voltage which is used in digital systems and easily provides the required interface electronics without requiring the additional  $\pm 15$  V power supplies.

#### Device Information<sup>(1)</sup>

PART NUMBER	PACKAGE	BODY SIZE (NOM)
LM124-N	CDIP (14)	19.56 mm x 6.67 mm
LM224-N		
LM324-N	CDIP (14)	19.56 mm x 6.67 mm
	PDIP (14)	19.177 mm x 6.35 mm
	SOIC (14)	8.65 mm x 3.91 mm
	TSSOP (14)	5.00 mm x 4.40 mm
LM2902-N	PDIP (14)	19.177 mm x 6.35 mm
	SOIC (14)	8.65 mm x 3.91 mm
	TSSOP (14)	5.00 mm x 4.40 mm

(1) For all available packages, see the orderable addendum at the end of the datasheet.

#### Schematic Diagram

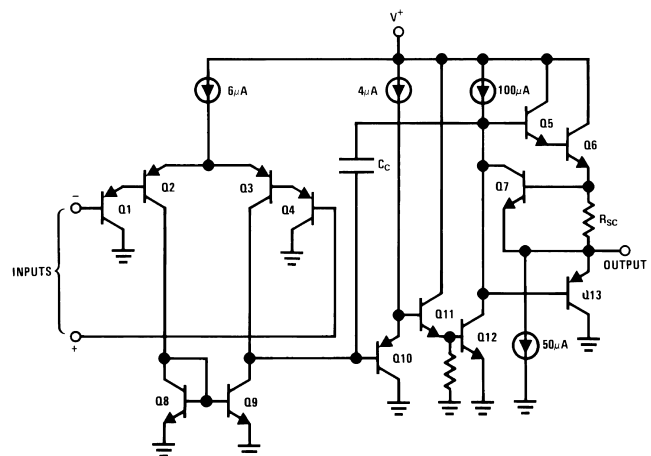

## Table of Contents

<b>1 Features</b> .....	1	7.3 Feature Description.....	11
<b>2 Applications</b> .....	1	7.4 Device Functional Modes.....	11
<b>3 Description</b> .....	1	<b>8 Application and Implementation</b> .....	13
<b>4 Revision History</b> .....	2	8.1 Application Information.....	13
<b>5 Pin Configuration and Functions</b> .....	3	8.2 Typical Applications .....	13
<b>6 Specifications</b> .....	4	<b>9 Power Supply Recommendations</b> .....	23
6.1 Absolute Maximum Ratings .....	4	<b>10 Layout</b> .....	23
6.2 ESD Ratings.....	4	10.1 Layout Guidelines .....	23
6.3 Recommended Operating Conditions.....	4	10.2 Layout Example .....	23
6.4 Thermal Information .....	5	<b>11 Device and Documentation Support</b> .....	24
6.5 Electrical Characteristics: LM124A/224A/324A .....	5	11.1 Related Links .....	24
6.6 Electrical Characteristics: LM124-N/224-N/324-N/2902-N .....	6	11.2 Trademarks .....	24
6.7 Typical Characteristics .....	8	11.3 Electrostatic Discharge Caution.....	24
<b>7 Detailed Description</b> .....	11	11.4 Glossary .....	24
7.1 Overview .....	11	<b>12 Mechanical, Packaging, and Orderable Information</b> .....	24
7.2 Functional Block Diagram .....	11		

## 4 Revision History

Changes from Revision C (November 2012) to Revision D	Page
<ul style="list-style-type: none"> <li>Added <i>Pin Configuration and Functions</i> section, <i>ESD Ratings</i> table, <i>Feature Description</i> section, <i>Device Functional Modes</i>, <i>Application and Implementation</i> section, <i>Power Supply Recommendations</i> section, <i>Layout</i> section, <i>Device and Documentation Support</i> section, and <i>Mechanical, Packaging, and Orderable Information</i> section .....</li> </ul>	1

## 5 Pin Configuration and Functions

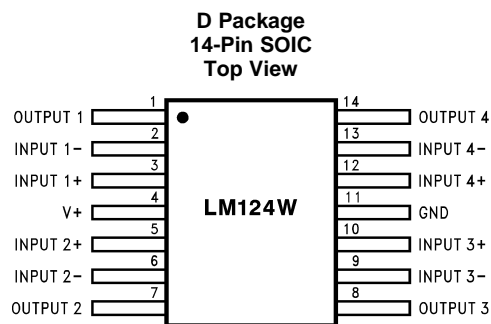
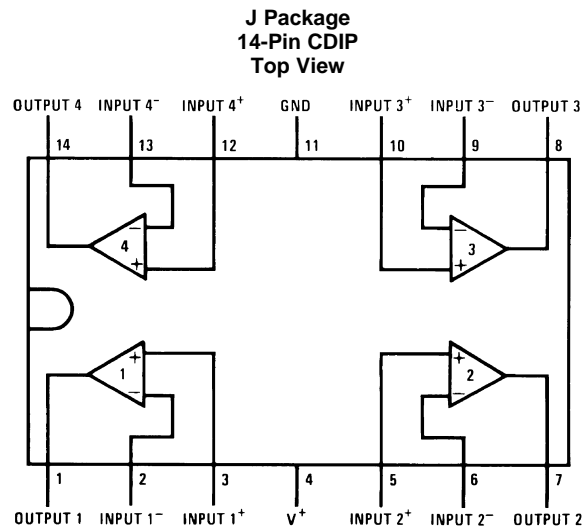

### Pin Functions

PIN		TYPE	DESCRIPTION
NAME	NO.		
OUTPUT1	1	O	Output, Channel 1
INPUT1-	2	I	Inverting Input, Channel 1
INPUT1+	3	I	Noninverting Input, Channel 1
V+	4	P	Positive Supply Voltage
INPUT2+	5	I	Noninverting Input, Channel 2
INPUT2-	6	I	Inverting Input, Channel 2
OUTPUT2	7	O	Output, Channel 2
OUTPUT3	8	O	Output, Channel 3
INPUT3-	9	I	Inverting Input, Channel 3
INPUT3+	10	I	Noninverting Input, Channel 3
GND	11	P	Ground or Negative Supply Voltage
INPUT4+	12	I	Noninverting Input, Channel 4
INPUT4-	13	I	Inverting Input, Channel 4
OUTPUT4	14	O	Output, Channel 4

## 6 Specifications

### 6.1 Absolute Maximum Ratings

See <sup>(1)(2)</sup>.

		LM124-N/LM224-N/LM324-N LM124A/LM224A/LM324A		LM2902-N			
		MIN	MAX	MIN	MAX	UNIT	
Supply Voltage, V <sup>+</sup>			32		26	V	
Differential Input Voltage			32		26	V	
Input Voltage		-0.3	32	-0.3	26	V	
Input Current (V <sub>IN</sub> < -0.3 V) <sup>(3)</sup>			50		50	mA	
Power Dissipation <sup>(4)</sup>	PDIP		1130		1130	mW	
	CDIP		1260		1260	mW	
	SOIC Package		800		800	mW	
Output Short-Circuit to GND (One Amplifier) <sup>(5)</sup>		V <sup>+</sup> ≤ 15 V and T <sub>A</sub> = 25°C	Continuous		Continuous		
Lead Temperature (Soldering, 10 seconds)			260		260	°C	
Soldering Information	Dual-In-Line Package	Soldering (10 seconds)	260		260	°C	
	Small Outline Package	Vapor Phase (60 seconds)	215		215	°C	
		Infrared (15 seconds)	220		220	°C	
Storage temperature, T <sub>stg</sub>			-65	150	-65	150	°C

- Refer to RETS124AX for LM124A military specifications and refer to RETS124X for LM124-N military specifications.
- If Military/Aerospace specified devices are required, please contact the Texas Instruments Sales Office/ Distributors for availability and specifications.
- This input current will only exist when the voltage at any of the input leads is driven negative. It is due to the collector-base junction of the input PNP transistors becoming forward biased and thereby acting as input diode clamps. In addition to this diode action, there is also lateral NPN parasitic transistor action on the IC chip. This transistor action can cause the output voltages of the op amps to go to the V<sup>+</sup> voltage level (or to ground for a large overdrive) for the time duration that an input is driven negative. This is not destructive and normal output states will re-establish when the input voltage, which was negative, again returns to a value greater than -0.3 V (at 25°C).
- For operating at high temperatures, the LM324-N/LM324A/LM2902-N must be derated based on a 125°C maximum junction temperature and a thermal resistance of 88°C/W which applies for the device soldered in a printed circuit board, operating in a still air ambient. The LM224-N/LM224A and LM124-N/LM124A can be derated based on a 150°C maximum junction temperature. The dissipation is the total of all four amplifiers—use external resistors, where possible, to allow the amplifier to saturate or to reduce the power which is dissipated in the integrated circuit.
- Short circuits from the output to V<sup>+</sup> can cause excessive heating and eventual destruction. When considering short circuits to ground, the maximum output current is approximately 40 mA independent of the magnitude of V<sup>+</sup>. At values of supply voltage in excess of 15 V, continuous short-circuits can exceed the power dissipation ratings and cause eventual destruction. Destructive dissipation can result from simultaneous shorts on all amplifiers.

### 6.2 ESD Ratings

			VALUE	UNIT
V <sub>(ESD)</sub>	Electrostatic discharge	Human-body model (HBM), per ANSI/ESDA/JEDEC JS-001 <sup>(1)</sup>	±250	V

- JEDEC document JEP155 states that 500-V HBM allows safe manufacturing with a standard ESD control process.

### 6.3 Recommended Operating Conditions

over operating free-air temperature range (unless otherwise noted)

	MIN	MAX	UNIT
Supply Voltage (V <sup>+</sup> - V <sup>-</sup> ): LM124-N/LM124A/LM224-N/LM224A/LM324-N/LM324A	3	32	V
Supply Voltage (V <sup>+</sup> - V <sup>-</sup> ): LM2902-N	3	26	V
Operating Input Voltage on Input pins	0	V <sup>+</sup>	V
Operating junction temperature, T <sub>J</sub> : LM124-N/LM124A	-55	125	°C
Operating junction temperature, T <sub>J</sub> : L2902-N	-40	85	°C
Operating junction temperature, T <sub>J</sub> : LM224-N/LM224A	-25	85	°C
Operating junction temperature, T <sub>J</sub> : LM324-N/LM324A	0	70	°C

## 6.4 Thermal Information

THERMAL METRIC <sup>(1)</sup>		LM124-N / LM224-N	LM324-N / LM2902-N	UNIT
		J/CDIP	D/SOIC	
		14 PINS	14 PINS	
R <sub>θJA</sub>	Junction-to-ambient thermal resistance	88	88	°C/W

(1) For more information about traditional and new thermal metrics, see the *IC Package Thermal Metrics* application report, [SPRA953](#).

## 6.5 Electrical Characteristics: LM124A/224A/324A

V<sup>+</sup> = 5.0 V, <sup>(1)</sup>, unless otherwise stated

PARAMETER	TEST CONDITIONS	LM124A			LM224A			LM324A			UNIT
		MIN	TYP	MAX	MIN	TYP	MAX	MIN	TYP	MAX	
Input Offset Voltage	T <sub>A</sub> = 25°C <sup>(2)</sup>		1	2		1	3		2	3	mV
Input Bias Current <sup>(3)</sup>	I <sub>IN(+)</sub> or I <sub>IN(-)</sub> , V <sub>CM</sub> = 0 V, T <sub>A</sub> = 25°C		20	50		40	80		45	100	nA
Input Offset Current	I <sub>IN(+)</sub> or I <sub>IN(-)</sub> , V <sub>CM</sub> = 0 V, T <sub>A</sub> = 25°C		2	10		2	15		5	30	nA
Input Common-Mode Voltage Range <sup>(4)</sup>	V <sup>+</sup> = 30 V, (LM2902-N, V <sup>+</sup> = 26 V), T <sub>A</sub> = 25°C	0		V <sup>+</sup> - 1.5	0		V <sup>+</sup> - 1.5	0		V <sup>+</sup> - 1.5	V
Supply Current	Over Full Temperature Range, R <sub>L</sub> = ∞ On All Op Amps V <sup>+</sup> = 30 V (LM2902-N V <sup>+</sup> = 26 V)		1.5	3		1.5	3		1.5	3	mA
	V <sup>+</sup> = 5 V		0.7	1.2		0.7	1.2		0.7	1.2	
Large Signal Voltage Gain	V <sup>+</sup> = 15 V, R <sub>L</sub> ≥ 2 kΩ, (V <sub>O</sub> = 1 V to 11 V), T <sub>A</sub> = 25°C	50	100		50	100		25	100		V/mV
Common-Mode Rejection Ratio	DC, V <sub>CM</sub> = 0 V to V <sup>+</sup> - 1.5 V, T <sub>A</sub> = 25°C	70	85		70	85		65	85		dB
Power Supply Rejection Ratio	V <sup>+</sup> = 5 V to 30 V, (LM2902-N, V <sup>+</sup> = 5 V to 26 V), T <sub>A</sub> = 25°C	65	100		65	100		65	100		dB
Amplifier-to-Amplifier Coupling <sup>(5)</sup>	f = 1 kHz to 20 kHz, T <sub>A</sub> = 25°C, (Input Referred)		-120			-120			-120		dB
Output Current	Source V <sub>IN<sup>+</sup></sub> = 1 V, V <sub>IN<sup>-</sup></sub> = 0 V, V <sup>+</sup> = 15 V, V <sub>O</sub> = 2 V, T <sub>A</sub> = 25°C		20	40		20	40		20	40	mA
	Sink V <sub>IN<sup>-</sup></sub> = 1 V, V <sub>IN<sup>+</sup></sub> = 0 V, V <sup>+</sup> = 15 V, V <sub>O</sub> = 2 V, T <sub>A</sub> = 25°C		10	20		10	20		10	20	
	Sink V <sub>IN<sup>-</sup></sub> = 1 V, V <sub>IN<sup>+</sup></sub> = 0 V, V <sup>+</sup> = 15 V, V <sub>O</sub> = 200 mV, T <sub>A</sub> = 25°C		12	50		12	50		12	50	
Short Circuit to Ground	V <sup>+</sup> = 15 V, T <sub>A</sub> = 25°C <sup>(6)</sup>		40	60		40	60		40	60	mA
Input Offset Voltage	See <sup>(2)</sup>			4			4			5	mV
V <sub>OS</sub> Drift	R <sub>S</sub> = 0 Ω		7	20		7	20		7	30	μV/°C
Input Offset Current	I <sub>IN(+)</sub> - I <sub>IN(-)</sub> , V <sub>CM</sub> = 0 V			30			30			75	nA

- These specifications are limited to -55°C ≤ T<sub>A</sub> ≤ +125°C for the LM124-N/LM124A. With the LM224-N/LM224A, all temperature specifications are limited to -25°C ≤ T<sub>A</sub> ≤ +85°C, the LM324-N/LM324A temperature specifications are limited to 0°C ≤ T<sub>A</sub> ≤ +70°C, and the LM2902-N specifications are limited to -40°C ≤ T<sub>A</sub> ≤ +85°C.
- V<sub>O</sub> = 1.4V, R<sub>S</sub> = 0 Ω with V<sup>+</sup> from 5 V to 30 V; and over the full input common-mode range (0 V to V<sup>+</sup> - 1.5 V) for LM2902-N, V<sup>+</sup> from 5 V to 26 V.
- The direction of the input current is out of the IC due to the PNP input stage. This current is essentially constant, independent of the state of the output so no loading change exists on the input lines.
- The input common-mode voltage of either input signal voltage should not be allowed to go negative by more than 0.3 V (at 25°C). The upper end of the common-mode voltage range is V<sup>+</sup> - 1.5 V (at 25°C), but either or both inputs can go to 32 V without damage (26 V for LM2902-N), independent of the magnitude of V<sup>+</sup>.
- Due to proximity of external components, insure that coupling is not originating via stray capacitance between these external parts. This typically can be detected as this type of capacitance increases at higher frequencies.
- Short circuits from the output to V<sup>+</sup> can cause excessive heating and eventual destruction. When considering short circuits to ground, the maximum output current is approximately 40 mA independent of the magnitude of V<sup>+</sup>. At values of supply voltage in excess of 15 V, continuous short-circuits can exceed the power dissipation ratings and cause eventual destruction. Destructive dissipation can result from simultaneous shorts on all amplifiers.

## Electrical Characteristics: LM124A/224A/324A (continued)

$V^+ = 5.0\text{ V}$ , <sup>(1)</sup>, unless otherwise stated

PARAMETER	TEST CONDITIONS	LM124A			LM224A			LM324A			UNIT
		MIN	TYP	MAX	MIN	TYP	MAX	MIN	TYP	MAX	
I <sub>OS</sub> Drift	R <sub>S</sub> = 0 Ω		10	200		10	200		10	300	pA/°C
Input Bias Current	I <sub>IN(+)</sub> or I <sub>IN(-)</sub>		40	100		40	100		40	200	nA
Input Common-Mode Voltage Range <sup>(4)</sup>	V <sup>+</sup> = 30 V, (LM2902-N, V <sup>+</sup> = 26 V)		0	V <sup>+</sup> -2		0	V <sup>+</sup> -2		0	V <sup>+</sup> -2	V
Large Signal Voltage Gain	V <sup>+</sup> = 15 V (V <sub>O</sub> Swing = 1 V to 11 V), R <sub>L</sub> ≥ 2 kΩ		25			25			15		V/mV
Output Voltage Swing	V <sub>OH</sub>	V <sup>+</sup> = 30 V (LM2902-N, V <sup>+</sup> = 26 V)	R <sub>L</sub> = 2 kΩ	26		26		26			V
			R <sub>L</sub> = 10 kΩ	27	28	27	28	27	28		
	V <sub>OL</sub>	V <sup>+</sup> = 5 V, R <sub>L</sub> = 10 kΩ	5	20	5	20	5	20			mV
Output Current	Source	V <sub>O</sub> = 2 V	V <sub>IN<sup>+</sup></sub> = +1V, V <sub>IN<sup>-</sup></sub> = 0V, V <sup>+</sup> = 15V	10	20	10	20	10	20		mA
	Sink			V <sub>IN<sup>-</sup></sub> = +1V, V <sub>IN<sup>+</sup></sub> = 0V, V <sup>+</sup> = 15V	10	15	5	8	5	8	

## 6.6 Electrical Characteristics: LM124-N/224-N/324-N/2902-N

$V^+ = +5.0\text{ V}$ , <sup>(1)</sup>, unless otherwise stated

PARAMETER	TEST CONDITIONS	LM124-N / LM224-N			LM324-N			LM2902-N			UNIT
		MIN	TYP	MAX	MIN	TYP	MAX	MIN	TYP	MAX	
Input Offset Voltage	T <sub>A</sub> = 25°C <sup>(2)</sup>		2	5		2	7		2	7	mV
Input Bias Current <sup>(3)</sup>	I <sub>IN(+)</sub> or I <sub>IN(-)</sub> , V <sub>CM</sub> = 0 V, T <sub>A</sub> = 25°C		45	150		45	250		45	250	nA
Input Offset Current	I <sub>IN(+)</sub> or I <sub>IN(-)</sub> , V <sub>CM</sub> = 0 V, T <sub>A</sub> = 25°C		3	30		5	50		5	50	nA
Input Common-Mode Voltage Range <sup>(4)</sup>	V <sup>+</sup> = 30 V, (LM2902-N, V <sup>+</sup> = 26V), T <sub>A</sub> = 25°C		0	V <sup>+</sup> -1.5		0	V <sup>+</sup> -1.5		0	V <sup>+</sup> -1.5	V
Supply Current	Over Full Temperature Range R <sub>L</sub> = ∞ On All Op Amps, V <sup>+</sup> = 30 V (LM2902-N V <sup>+</sup> = 26 V)		1.5	3		1.5	3		1.5	3	mA
	V <sup>+</sup> = 5 V		0.7	1.2		0.7	1.2		0.7	1.2	
Large Signal Voltage Gain	V <sup>+</sup> = 15V, R <sub>L</sub> ≥ 2 kΩ, (V <sub>O</sub> = 1 V to 11 V), T <sub>A</sub> = 25°C		50	100		25	100		25	100	V/mV
Common-Mode Rejection Ratio	DC, V <sub>CM</sub> = 0 V to V <sup>+</sup> - 1.5 V, T <sub>A</sub> = 25°C		70	85		65	85		50	70	dB
Power Supply Rejection Ratio	V <sup>+</sup> = 5 V to 30 V (LM2902-N, V <sup>+</sup> = 5 V to 26 V), T <sub>A</sub> = 25°C		65	100		65	100		50	100	dB
Amplifier-to-Amplifier Coupling <sup>(5)</sup>	f = 1 kHz to 20 kHz, T <sub>A</sub> = 25°C (Input Referred)		-120			-120			-120		dB

- (1) These specifications are limited to  $-55^\circ\text{C} \leq T_A \leq +125^\circ\text{C}$  for the LM124-N/LM124A. With the LM224-N/LM224A, all temperature specifications are limited to  $-25^\circ\text{C} \leq T_A \leq +85^\circ\text{C}$ , the LM324-N/LM324A temperature specifications are limited to  $0^\circ\text{C} \leq T_A \leq +70^\circ\text{C}$ , and the LM2902-N specifications are limited to  $-40^\circ\text{C} \leq T_A \leq +85^\circ\text{C}$ .
- (2) V<sub>O</sub> = 1.4V, R<sub>S</sub> = 0 Ω with V<sup>+</sup> from 5 V to 30 V; and over the full input common-mode range (0 V to V<sup>+</sup> - 1.5 V) for LM2902-N, V<sup>+</sup> from 5 V to 26 V.
- (3) The direction of the input current is out of the IC due to the PNP input stage. This current is essentially constant, independent of the state of the output so no loading change exists on the input lines.
- (4) The input common-mode voltage of either input signal voltage should not be allowed to go negative by more than 0.3 V (at 25°C). The upper end of the common-mode voltage range is V<sup>+</sup> - 1.5 V (at 25°C), but either or both inputs can go to 32 V without damage (26 V for LM2902-N), independent of the magnitude of V<sup>+</sup>.
- (5) Due to proximity of external components, insure that coupling is not originating via stray capacitance between these external parts. This typically can be detected as this type of capacitance increases at higher frequencies.

**Electrical Characteristics: LM124-N/224-N/324-N/2902-N (continued)**
 $V^+ = +5.0V$ , <sup>(1)</sup>, unless otherwise stated

PARAMETER		TEST CONDITIONS		LM124-N / LM224-N			LM324-N			LM2902-N			UNIT
				MIN	TYP	MAX	MIN	TYP	MAX	MIN	TYP	MAX	
Output Current	Source	$V_{IN^+} = 1V, V_{IN^-} = 0V, V^+ = 15V, V_O = 2V, T_A = 25^\circ C$		20	40		20	40		20	40		mA
	Sink	$V_{IN^-} = 1V, V_{IN^+} = 0V, V^+ = 15V, V_O = 2V, T_A = 25^\circ C$		10	20		10	20		10	20		mA
		$V_{IN^-} = 1V, V_{IN^+} = 0V, V^+ = 15V, V_O = 200mV, T_A = 25^\circ C$		12	50		12	50		12	50		$\mu A$
Short Circuit to Ground		$V^+ = 15V, T_A = 25^\circ C$ <sup>(6)</sup>			40	60		40	60		40	60	mA
Input Offset Voltage		See <sup>(2)</sup>				7			9			10	mV
$V_{OS}$ Drift		$R_S = 0\Omega$			7			7			7		$\mu V/^\circ C$
Input Offset Current		$I_{IN(+)} - I_{IN(-)}, V_{CM} = 0V$				100			150		45	200	nA
$I_{OS}$ Drift		$R_S = 0\Omega$			10			10			10		$pA/^\circ C$
Input Bias Current		$I_{IN(+)}$ or $I_{IN(-)}$			40	300		40	500		40	500	nA
Input Common-Mode Voltage Range <sup>(4)</sup>		$V^+ = 30V, (LM2902-N, V^+ = 26V)$		0		$V^+ - 2$	0		$V^+ - 2$	0		$V^+ - 2$	V
Large Signal Voltage Gain		$V^+ = 15V (V_{OSwing} = 1V \text{ to } 11V), R_L \geq 2k\Omega$		25			15			15			V/mV
Output Voltage Swing	$V_{OH}$	$V^+ = 30V (LM2902-N, V^+ = 26V)$	$R_L = 2k\Omega$	26			26			22			V
			$R_L = 10k\Omega$	27	28		27	28		23	24		
	$V_{OL}$	$V^+ = 5V, R_L = 10k\Omega$		5	20		5	20		5	100		mV
Output Current	Source	$V_O = 2V$	$V_{IN^+} = 1V, V_{IN^-} = 0V, V^+ = 15V$	10	20		10	20		10	20		mA
	Sink		$V_{IN^-} = 1V, V_{IN^+} = 0V, V^+ = 15V$	5	8		5	8		5	8		mA

(6) Short circuits from the output to  $V^+$  can cause excessive heating and eventual destruction. When considering short circuits to ground, the maximum output current is approximately 40 mA independent of the magnitude of  $V^+$ . At values of supply voltage in excess of 15 V, continuous short-circuits can exceed the power dissipation ratings and cause eventual destruction. Destructive dissipation can result from simultaneous shorts on all amplifiers.

## 6.7 Typical Characteristics

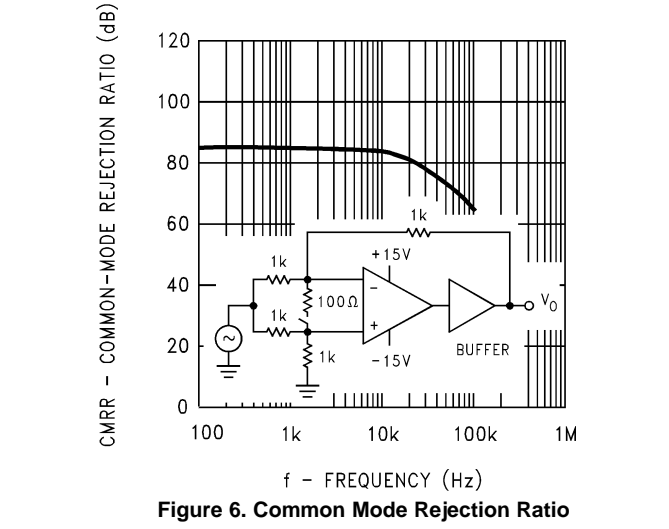
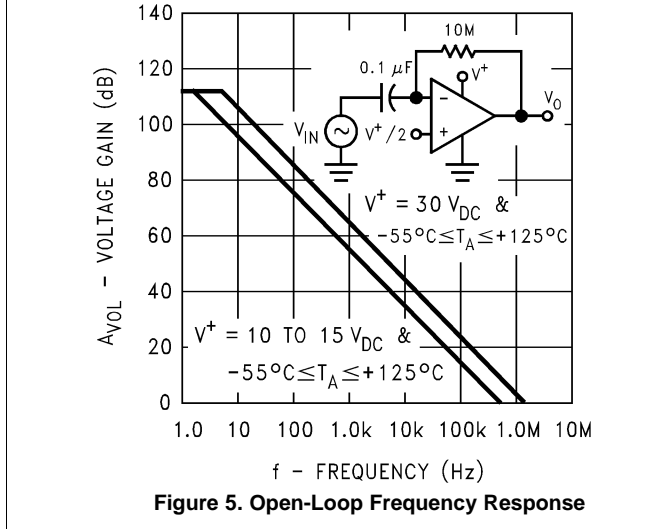
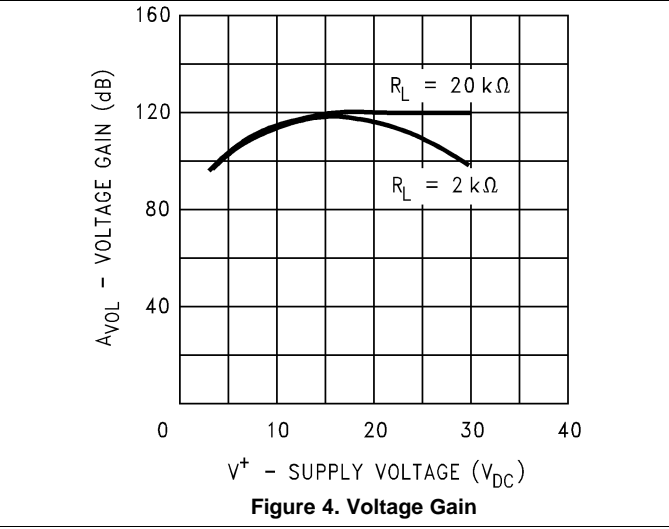
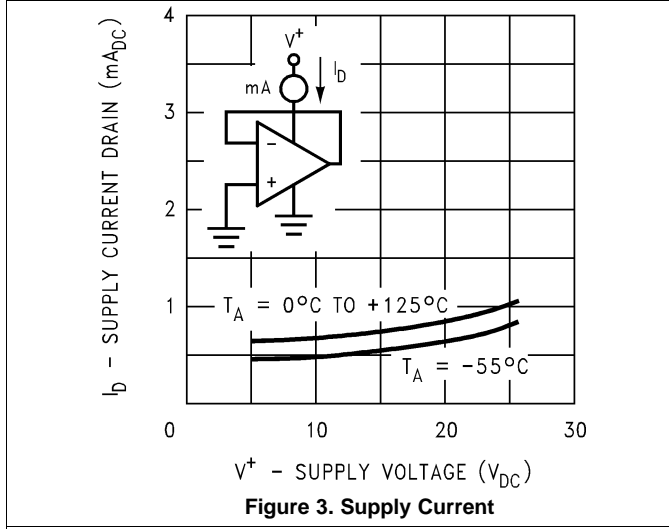
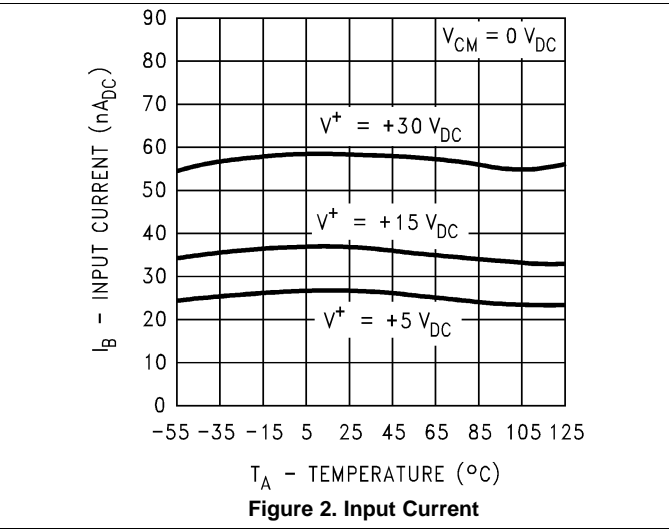
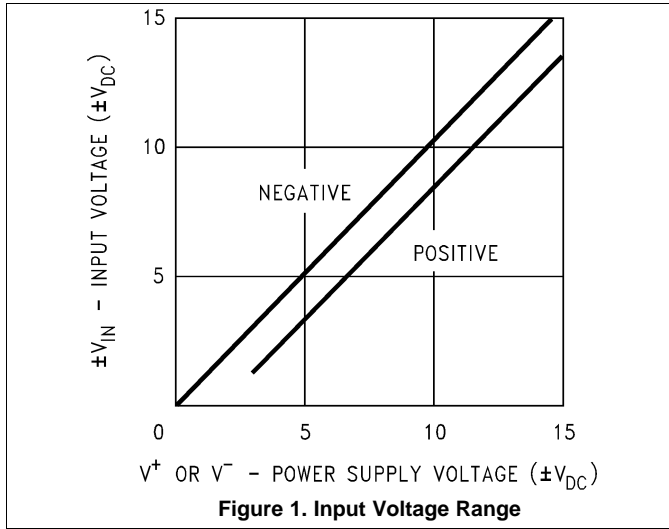

Typical Characteristics (continued)

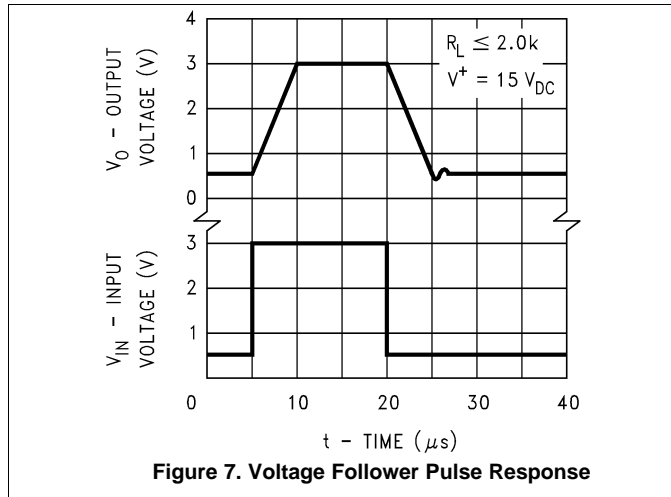

Figure 7. Voltage Follower Pulse Response

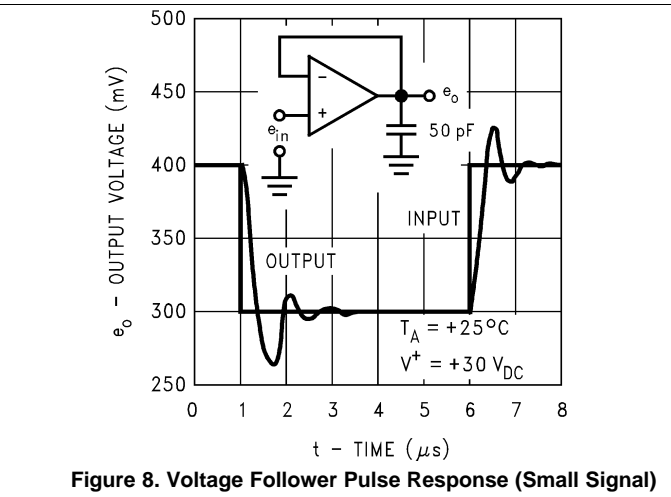

Figure 8. Voltage Follower Pulse Response (Small Signal)

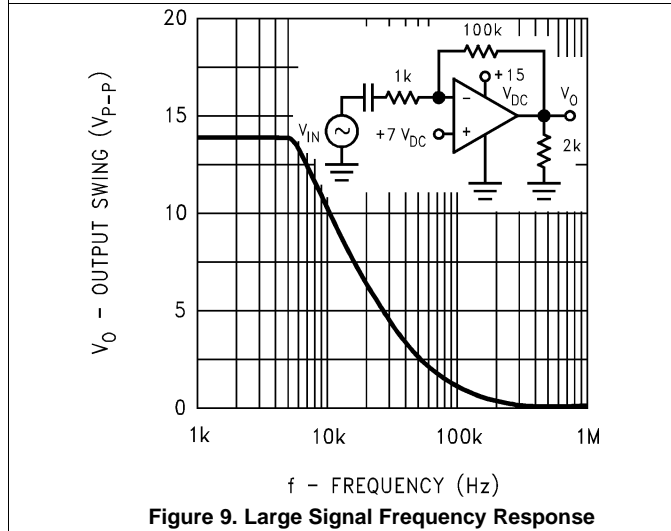

Figure 9. Large Signal Frequency Response

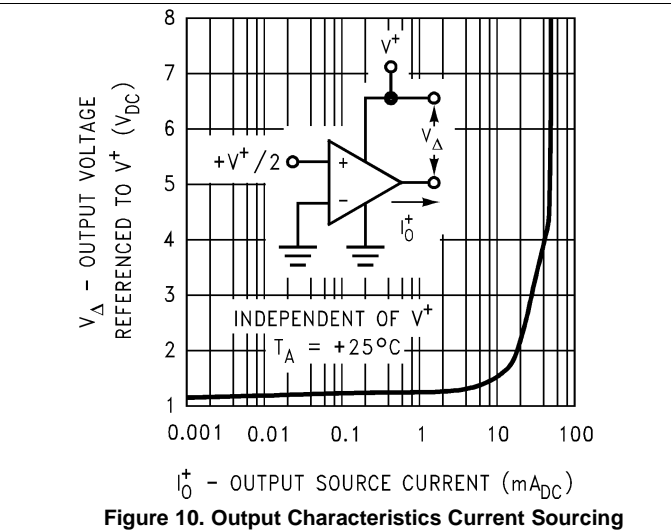

Figure 10. Output Characteristics Current Sourcing

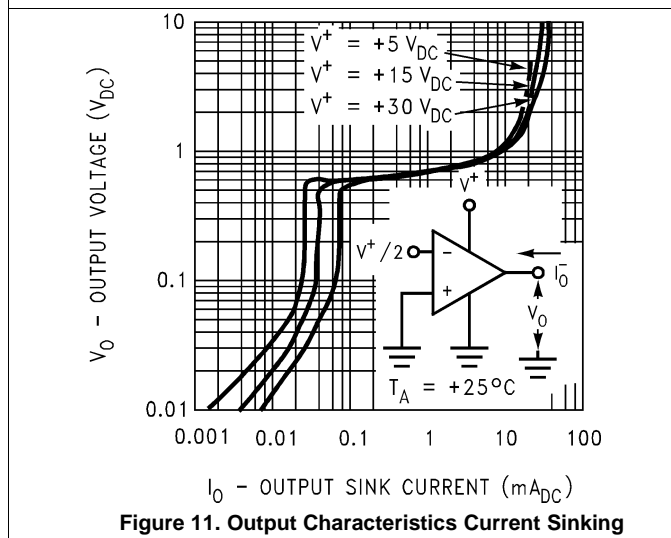

Figure 11. Output Characteristics Current Sinking

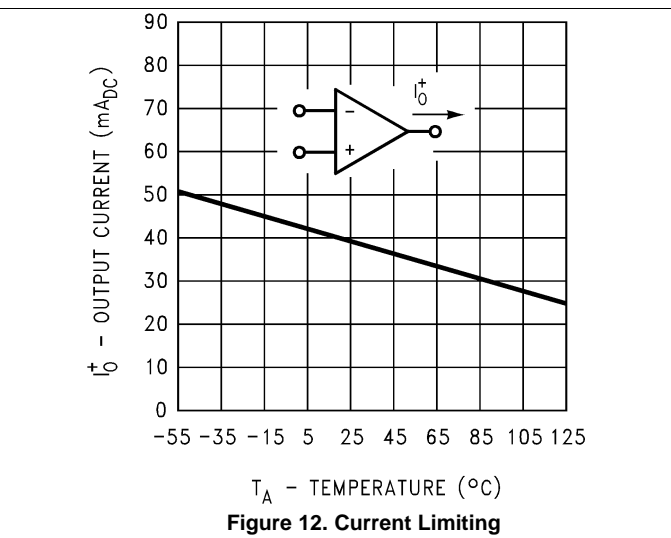
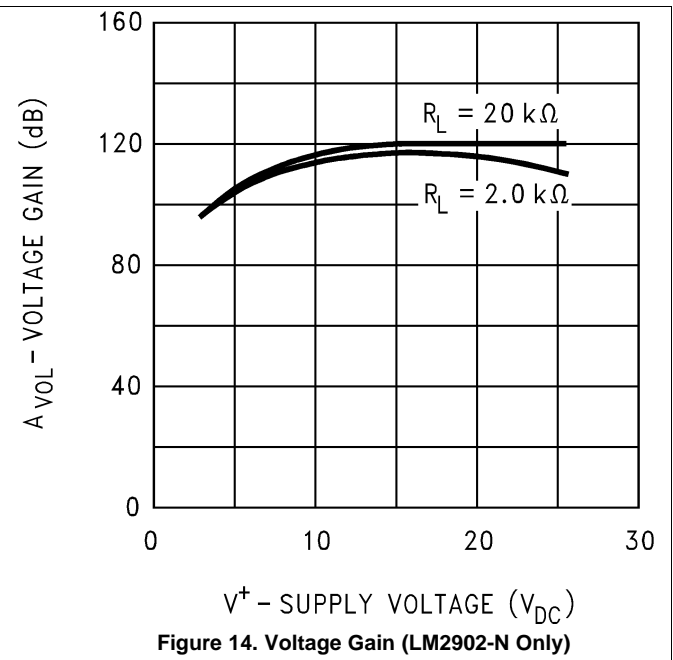
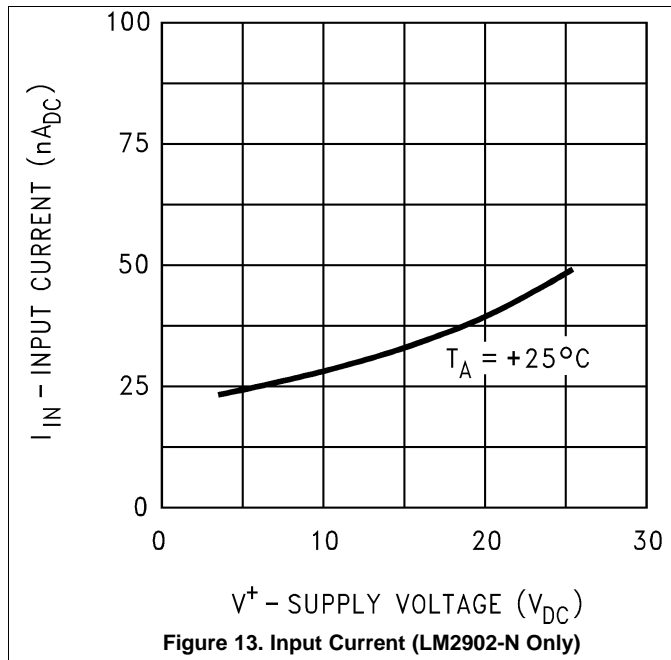

Figure 12. Current Limiting

Typical Characteristics (continued)



## 7 Detailed Description

### 7.1 Overview

The LM124-N series are op amps which operate with only a single power supply voltage, have true-differential inputs, and remain in the linear mode with an input common-mode voltage of 0 V<sub>DC</sub>. These amplifiers operate over a wide range of power supply voltage with little change in performance characteristics. At 25°C amplifier operation is possible down to a minimum supply voltage of 2.3 V<sub>DC</sub>.

### 7.2 Functional Block Diagram

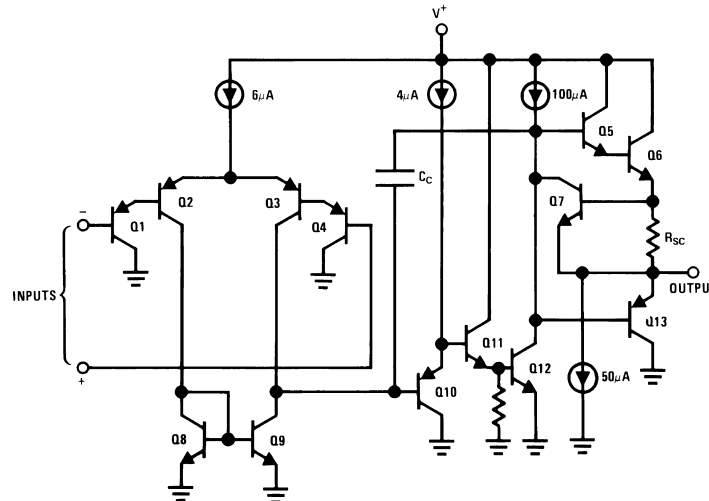

### 7.3 Feature Description

The LM124 provides a compelling balance of performance versus current consumption. The 700 µA of supply current draw over the wide operating conditions with a 1-MHz gain-bandwidth and temperature compensated bias currents makes the LM124 an effective solution for large variety of applications. The input offset voltage of 2 mV and offset current of 5 nA, along with the 45n-A bias current across a wide supply voltage means a single design can be used in a large number of different implementations.

### 7.4 Device Functional Modes

Large differential input voltages can be easily accommodated and, as input differential voltage protection diodes are not needed, no large input currents result from large differential input voltages. The differential input voltage may be larger than V<sup>+</sup> without damaging the device. Protection should be provided to prevent the input voltages from going negative more than -0.3 V<sub>DC</sub> (at 25°C). An input clamp diode with a resistor to the IC input terminal can be used.

To reduce the power supply drain, the amplifiers have a class A output stage for small signal levels which converts to class B in a large signal mode. This allows the amplifiers to both source and sink large output currents. Therefore both NPN and PNP external current boost transistors can be used to extend the power capability of the basic amplifiers. The output voltage needs to raise approximately 1 diode drop above ground to bias the on-chip vertical PNP transistor for output current sinking applications.

For ac applications, where the load is capacitively coupled to the output of the amplifier, a resistor should be used, from the output of the amplifier to ground to increase the class A bias current and prevent crossover distortion.

Where the load is directly coupled, as in dc applications, there is no crossover distortion.

Capacitive loads which are applied directly to the output of the amplifier reduce the loop stability margin. Values of 50 pF can be accommodated using the worst-case non-inverting unity gain connection. Large closed loop gains or resistive isolation should be used if larger load capacitance must be driven by the amplifier.

## Device Functional Modes (continued)

The bias network of the LM124-N establishes a drain current which is independent of the magnitude of the power supply voltage over the range of from  $3 V_{DC}$  to  $30 V_{DC}$ .

Output short circuits either to ground or to the positive power supply should be of short time duration. Units can be destroyed, not as a result of the short circuit current causing metal fusing, but rather due to the large increase in IC chip dissipation which will cause eventual failure due to excessive junction temperatures. Putting direct short-circuits on more than one amplifier at a time will increase the total IC power dissipation to destructive levels, if not properly protected with external dissipation limiting resistors in series with the output leads of the amplifiers. The larger value of output source current which is available at 25°C provides a larger output current capability at elevated temperatures (see [Typical Characteristics](#)) than a standard IC op amp.

## 8 Application and Implementation

### NOTE

Information in the following applications sections is not part of the TI component specification, and TI does not warrant its accuracy or completeness. TI's customers are responsible for determining suitability of components for their purposes. Customers should validate and test their design implementation to confirm system functionality.

### 8.1 Application Information

The LM124 series of amplifiers is specified for operation from 3 V to 32 V ( $\pm 1.5$  V to  $\pm 16$  V). Many of the specifications apply from  $-40^{\circ}\text{C}$  to  $125^{\circ}\text{C}$ . Parameters that can exhibit significant variance with regards to operating voltage or temperature are presented in *Typical Characteristics*.

### 8.2 Typical Applications

Figure 15 emphasizes operation on only a single power supply voltage. If complementary power supplies are available, all of the standard op amp circuits can be used. In general, introducing a pseudo-ground (a bias voltage reference of  $V^+/2$ ) will allow operation above and below this value in single power supply systems. Many application circuits are shown which take advantage of the wide input common-mode voltage range which includes ground. In most cases, input biasing is not required and input voltages which range to ground can easily be accommodated.

#### 8.2.1 Non-Inverting DC Gain (0 V Input = 0 V Output)

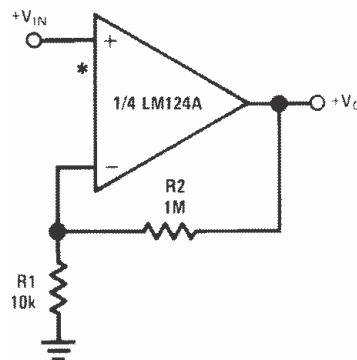

\*R not needed due to temperature independent  $I_{IN}$

Figure 15. Non-Inverting Amplifier with  $G=100$

#### 8.2.1.1 Design Requirements

For this example application, the required signal gain is a non-inverting  $100x \pm 5\%$  with a supply voltage of 5 V.

#### 8.2.1.2 Detailed Design Procedure

Using the equation for a non-inverting gain configuration,  $A_v = 1 + R_2/R_1$ . Setting the  $R_1$  to 10 k $\Omega$ ,  $R_2$  is 99 times larger than  $R_1$ , which is 990 k $\Omega$ . A 1M $\Omega$  is more readily available, and provides a gain of 101, which is within the desired specification.

The gain-frequency characteristic of the amplifier and its feedback network must be such that oscillation does not occur. To meet this condition, the phase shift through amplifier and feedback network must never exceed  $180^{\circ}$  for any frequency where the gain of the amplifier and its feedback network is greater than unity. In practical applications, the phase shift should not approach  $180^{\circ}$  since this is the situation of conditional stability. Obviously the most critical case occurs when the attenuation of the feedback network is zero.

## Typical Applications (continued)

### 8.2.1.3 Application Curve

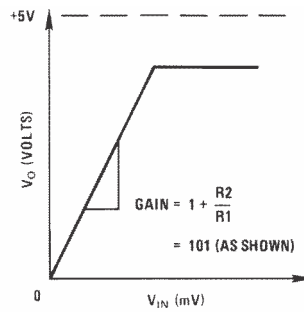
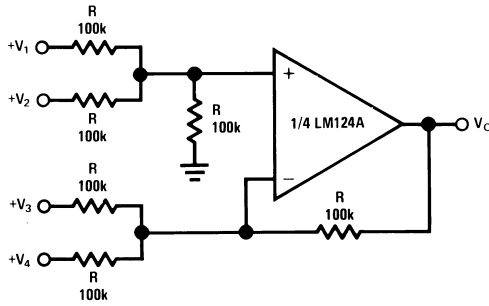

Figure 16. Non-Inverting Amplified Response Curve

Typical Applications (continued)

8.2.2 Other Application Circuits at  $V^+ = 5.0 V_{DC}$



Where:  $V_0 = V_1 + V_2 - V_3 - V_4$   
 $(V_1 + V_2) \geq (V_3 + V_4)$  to keep  $V_0 > 0 V_{DC}$

Figure 17. DC Summing Amplifier  
 $(V_{IN}'S \geq 0 V_{DC}$  And  $V_0 \geq V_{DC}$ )

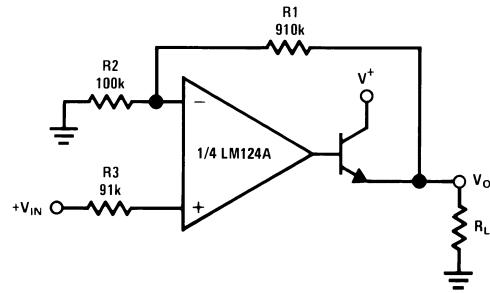

Where:  $V_0 = 0 V_{DC}$  for  $V_{IN} = 0 V_{DC}$   
 $A_V = 10$

Figure 18. Power Amplifier

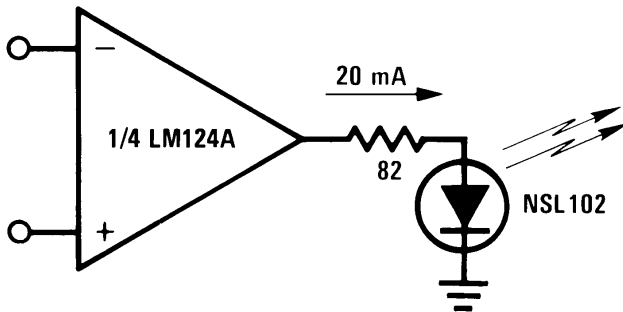
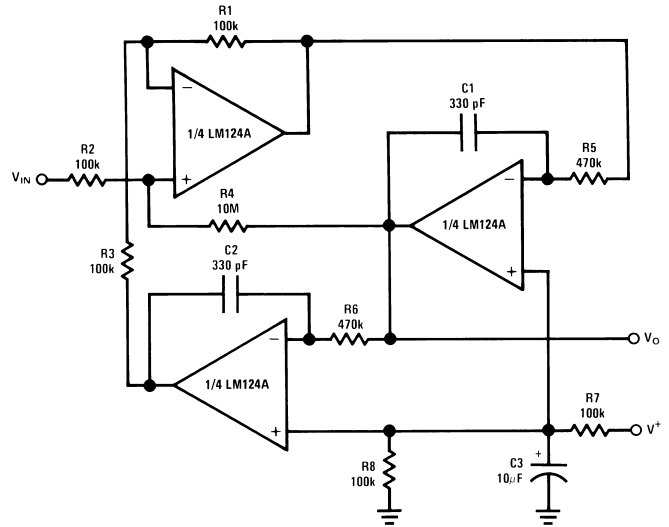

Figure 19. LED Driver



$f_0 = 1 \text{ kHz}$      $Q = 50$      $A_V = 100$  (40 dB)

Figure 20. "BI-QUAD" RC Active Bandpass Filter

Typical Applications (continued)

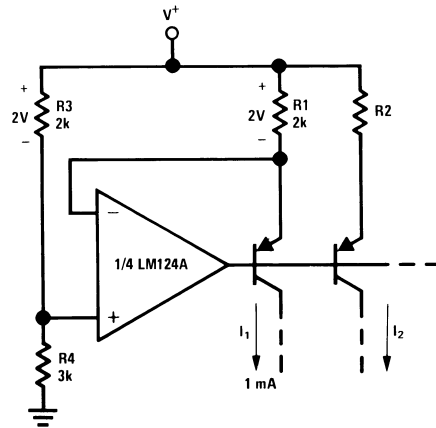

$$I_2 = \left( \frac{R_1}{R_2} \right) I_1$$

Figure 21. Fixed Current Sources

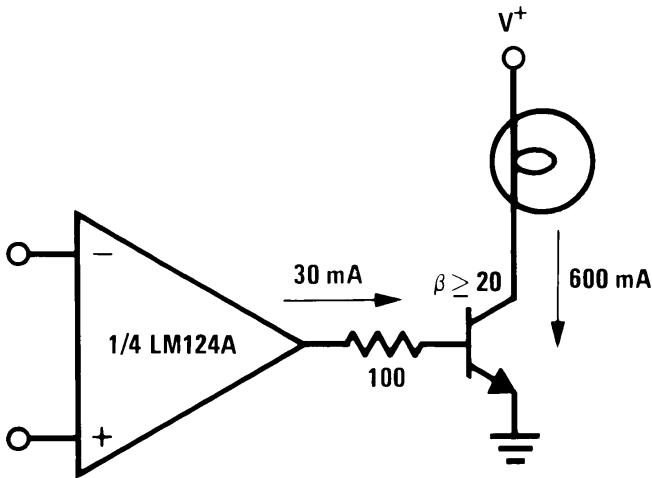
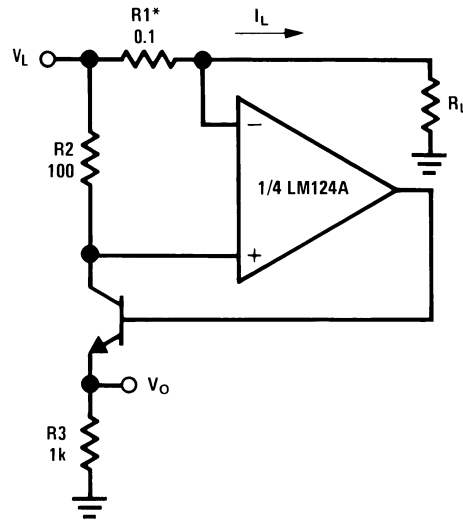

Figure 22. Lamp Driver



\*(Increase R1 for  $I_L$  small)

Figure 23. Current Monitor

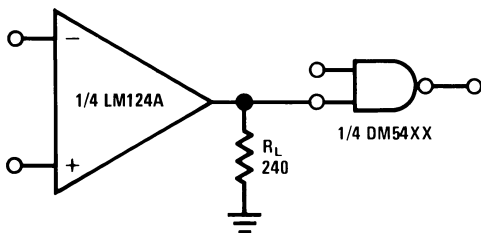

Figure 24. Driving TTL

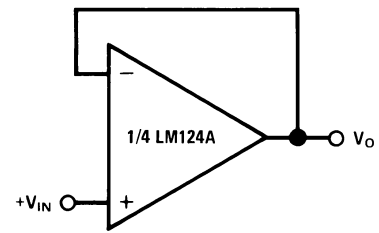

Figure 25. Voltage Follower

Typical Applications (continued)

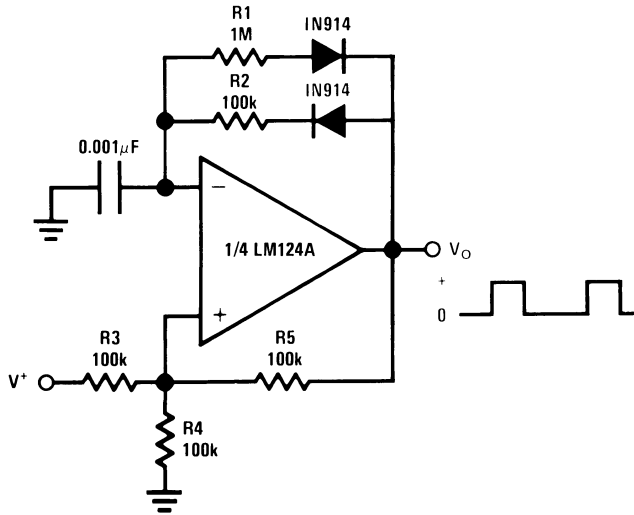

Figure 26. Pulse Generator

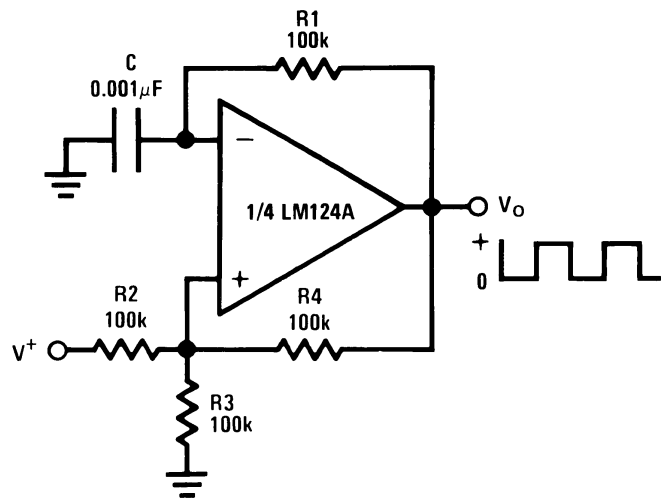

Figure 27. Squarewave Oscillator

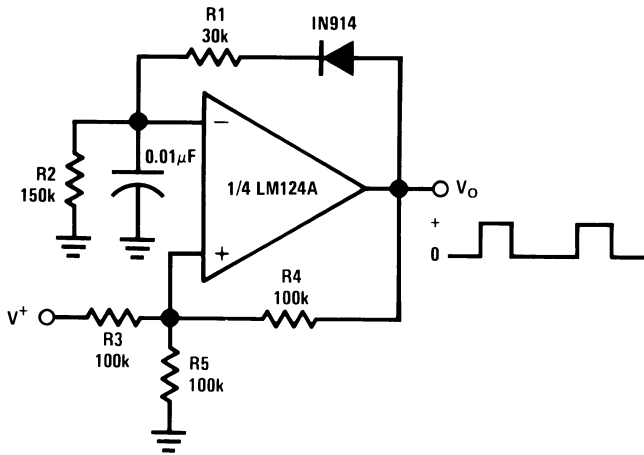
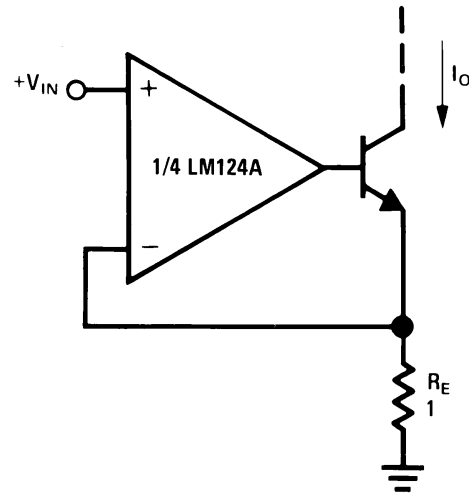

Figure 28. Pulse Generator



$I_O = 1 \text{ amp/volt } V_{IN}$  (Increase  $R_E$  for  $I_O$  small)

Figure 29. High Compliance Current Sink

Typical Applications (continued)

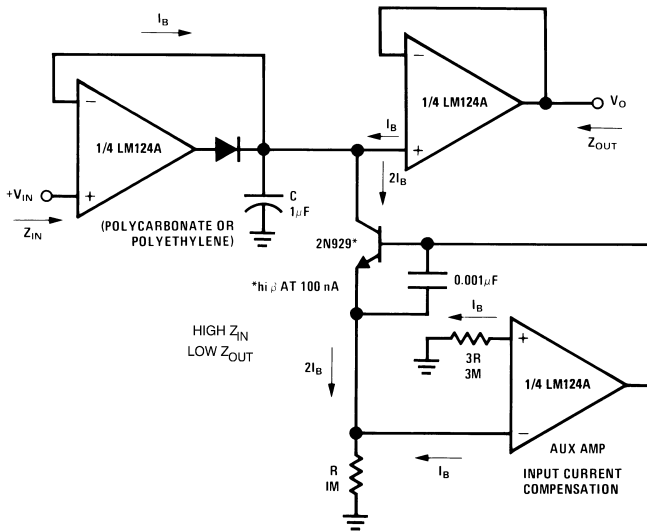

Figure 30. Low Drift Peak Detector

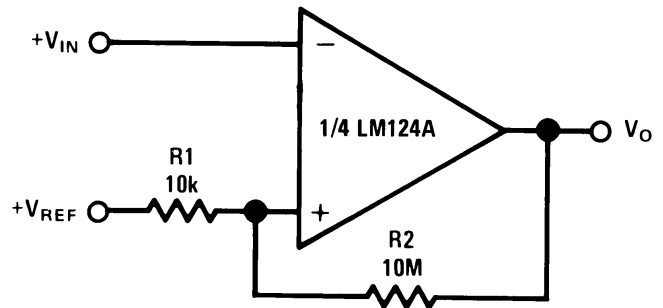
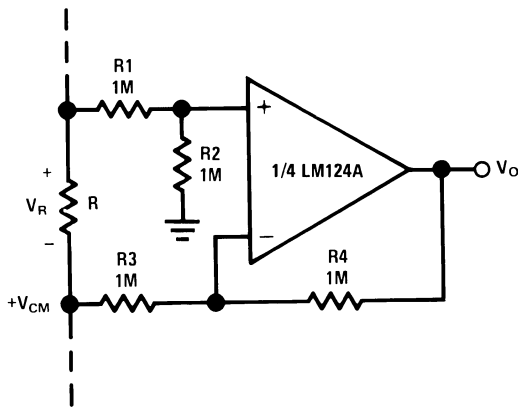
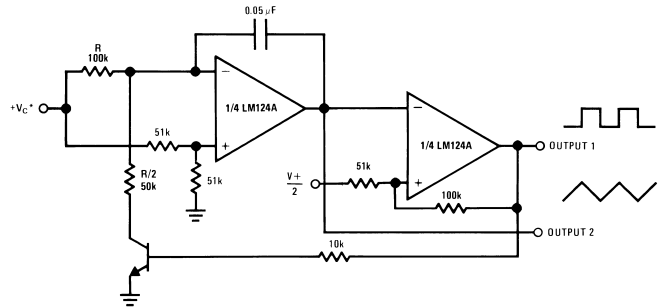

Figure 31. Comparator With Hysteresis



$$V_O = V_R$$

Figure 32. Ground Referencing a Differential Input Signal



\*Wide control voltage range:  
 $0 V_{DC} \leq V_C \leq 2 (V^+ - 1.5 V_{DC})$

Figure 33. Voltage Controlled Oscillator Circuit

Typical Applications (continued)

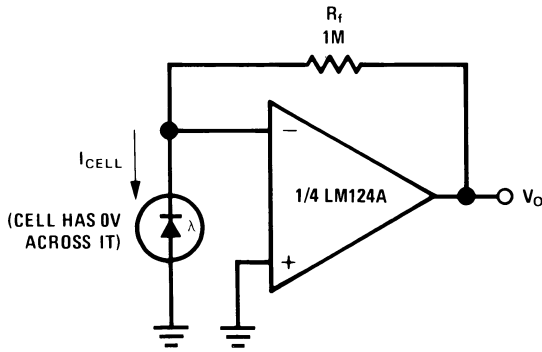

$Q = 1$        $A_V = 2$

Figure 34. Photo Voltaic-Cell Amplifier

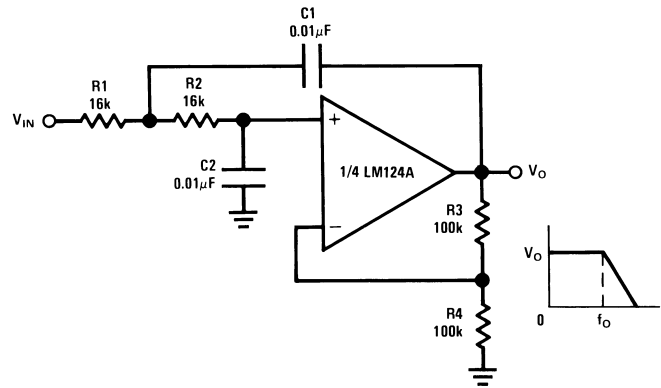
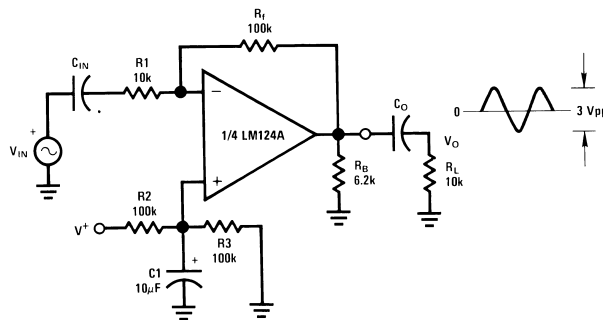
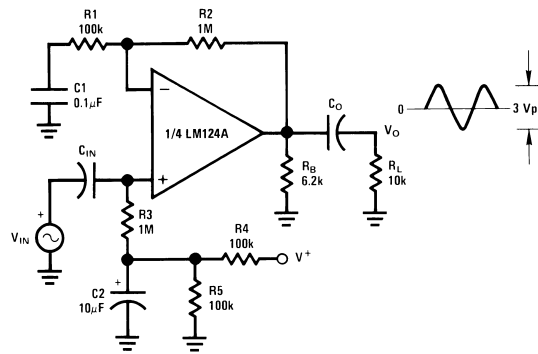

Figure 35. DC Coupled Low-Pass RC Active Filter



$A_V = \frac{R_f}{R_1}$  (As shown,  $A_V = 10$ )

Figure 36. AC Coupled Inverting Amplifier



$A_V = 1 + \frac{R_2}{R_1}$   
 $A_V = 11$  (As shown)

Figure 37. AC Coupled Non-Inverting Amplifier

Typical Applications (continued)

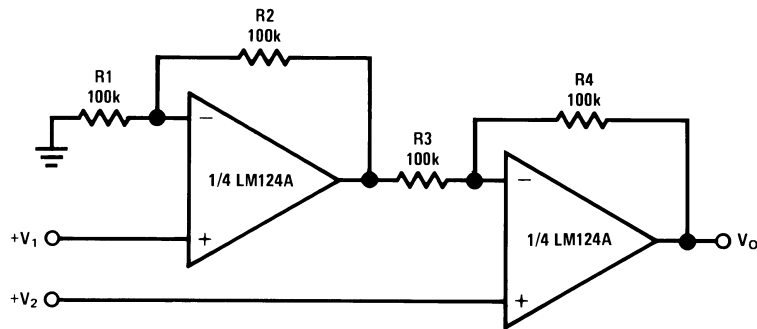

For  $\frac{R1}{R2} = \frac{R4}{R3}$  (CMRR depends on this resistor ratio match)

$$V_O = 1 + \frac{R4}{R3} (V_2 - V_1)$$

As shown:  $V_O = 2(V_2 - V_1)$

Figure 38. High Input Z, DC Differential Amplifier

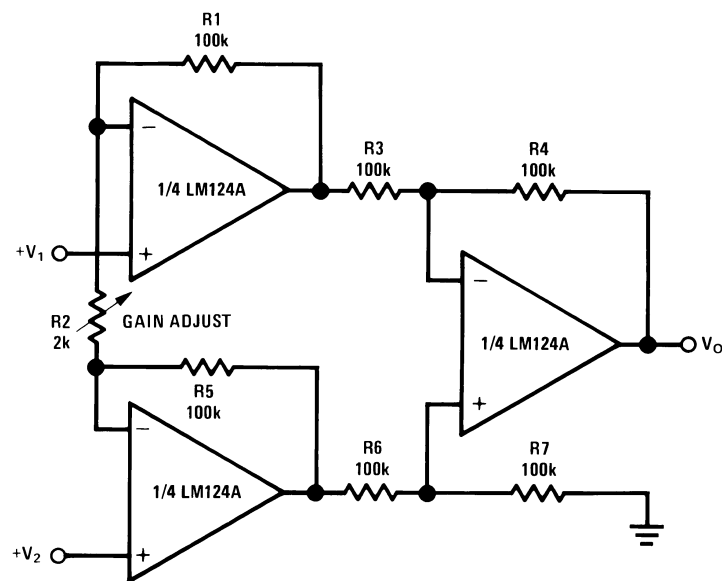

If  $R1 = R5$  &  $R3 = R4 = R6 = R7$  (CMRR depends on match)

$$V_O = 1 + \frac{2R1}{R2} (V_2 - V_1)$$

As shown  $V_O = 101 (V_2 - V_1)$

Figure 39. High Input Z Adjustable-Gain DC Instrumentation Amplifier

Typical Applications (continued)

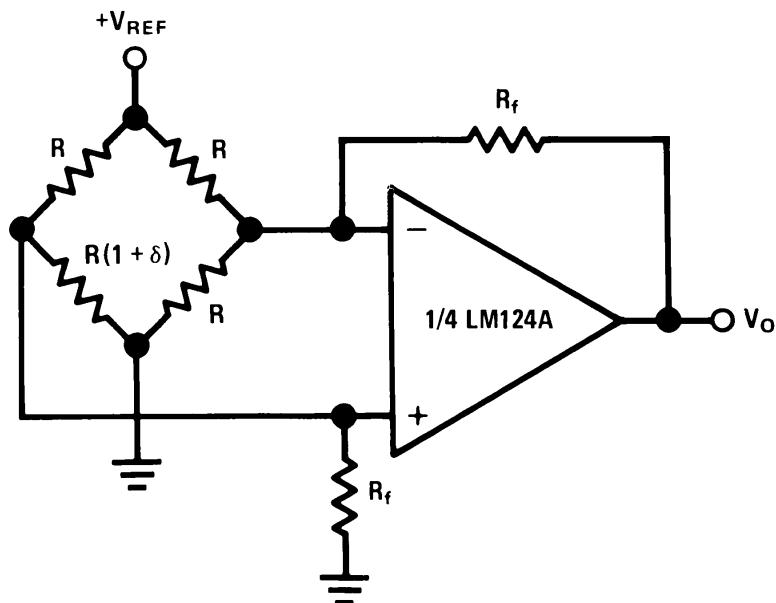

For  $\delta \ll 1$  and  $R_f \gg R$   

$$V_O \approx V_{REF} \left( \frac{\delta}{2} \right) \frac{R_f}{R}$$

Figure 40. Bridge Current Amplifier

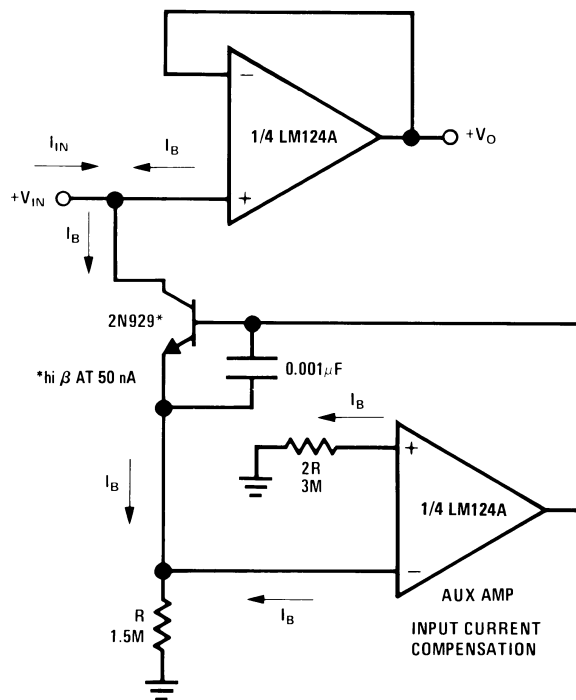
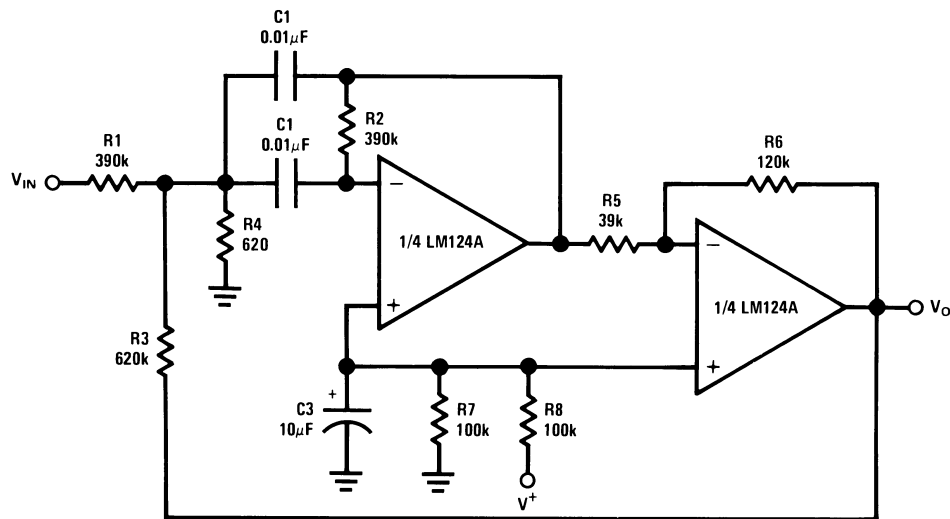

Figure 41. Using Symmetrical Amplifiers to Reduce Input Current (General Concept)

Typical Applications (continued)



$f_o = 1 \text{ kHz}$

$Q = 25$

Figure 42. Bandpass Active Filter

## 9 Power Supply Recommendations

The pinouts of the package have been designed to simplify PC board layouts. Inverting inputs are adjacent to outputs for all of the amplifiers and the outputs have also been placed at the corners of the package (pins 1, 7, 8, and 14).

Precautions should be taken to insure that the power supply for the integrated circuit never becomes reversed in polarity or that the unit is not inadvertently installed backwards in a test socket as an unlimited current surge through the resulting forward diode within the IC could cause fusing of the internal conductors and result in a destroyed unit.

## 10 Layout

### 10.1 Layout Guidelines

The V + pin should be bypassed to ground with a low-ESR capacitor. The optimum placement is closest to the V + and ground pins.

Take care to minimize the loop area formed by the bypass capacitor connection between V + and ground.

The ground pin should be connected to the PCB ground plane at the pin of the device.

The feedback components should be placed as close to the device as possible minimizing strays.

### 10.2 Layout Example

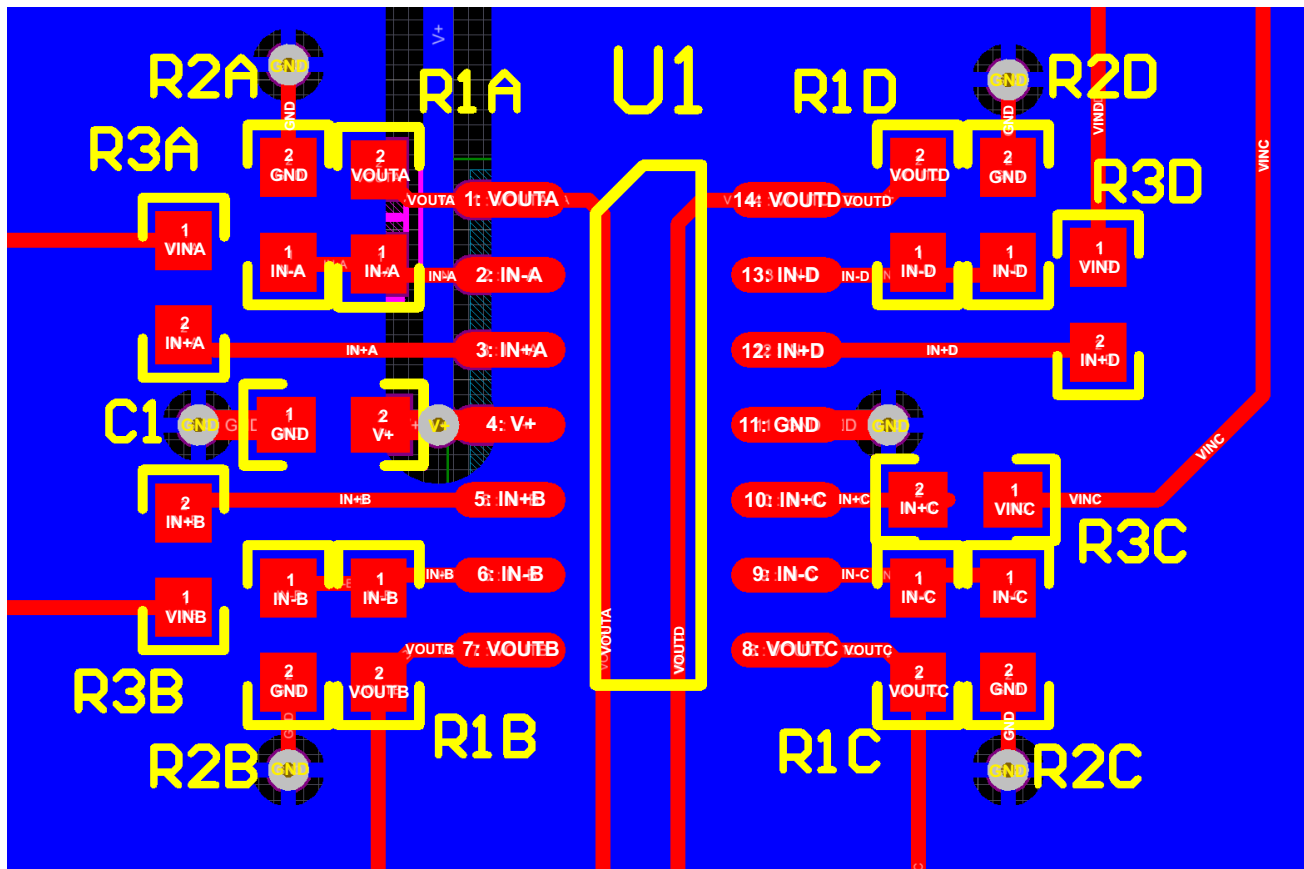

Figure 43. Layout Example

## 11 Device and Documentation Support

### 11.1 Related Links

The table below lists quick access links. Categories include technical documents, support and community resources, tools and software, and quick access to sample or buy.

Table 1. Related Links

PARTS	PRODUCT FOLDER	SAMPLE & BUY	TECHNICAL DOCUMENTS	TOOLS & SOFTWARE	SUPPORT & COMMUNITY
LM124-N	<a href="#">Click here</a>	<a href="#">Click here</a>	<a href="#">Click here</a>	<a href="#">Click here</a>	<a href="#">Click here</a>
LM224-N	<a href="#">Click here</a>	<a href="#">Click here</a>	<a href="#">Click here</a>	<a href="#">Click here</a>	<a href="#">Click here</a>
LM2902-N	<a href="#">Click here</a>	<a href="#">Click here</a>	<a href="#">Click here</a>	<a href="#">Click here</a>	<a href="#">Click here</a>
LM324-N	<a href="#">Click here</a>	<a href="#">Click here</a>	<a href="#">Click here</a>	<a href="#">Click here</a>	<a href="#">Click here</a>

### 11.2 Trademarks

All trademarks are the property of their respective owners.

### 11.3 Electrostatic Discharge Caution



These devices have limited built-in ESD protection. The leads should be shorted together or the device placed in conductive foam during storage or handling to prevent electrostatic damage to the MOS gates.

### 11.4 Glossary

[SLYZ022](#) — *TI Glossary*.

This glossary lists and explains terms, acronyms, and definitions.

## 12 Mechanical, Packaging, and Orderable Information

The following pages include mechanical, packaging, and orderable information. This information is the most current data available for the designated devices. This data is subject to change without notice and revision of this document. For browser-based versions of this data sheet, refer to the left-hand navigation.

**PACKAGING INFORMATION**

Orderable Device	Status (1)	Package Type	Package Drawing	Pins	Package Qty	Eco Plan (2)	Lead/Ball Finish (6)	MSL Peak Temp (3)	Op Temp (°C)	Device Marking (4/5)	Samples
LM124AJ/PB	ACTIVE	CDIP	J	14	25	TBD	Call TI	Call TI	-55 to 125	LM124AJ	<a href="#">Samples</a>
LM124J/PB	ACTIVE	CDIP	J	14	25	TBD	Call TI	Call TI	-55 to 125	LM124J	<a href="#">Samples</a>
LM224J	ACTIVE	CDIP	J	14	25	TBD	Call TI	Call TI	-25 to 85	LM224J	<a href="#">Samples</a>
LM2902M	NRND	SOIC	D	14	55	TBD	Call TI	Call TI	-40 to 85	LM2902M	
LM2902M/NOPB	ACTIVE	SOIC	D	14	55	Green (RoHS & no Sb/Br)	CU SN   Call TI	Level-1-260C-UNLIM	-40 to 85	LM2902M	<a href="#">Samples</a>
LM2902MT	NRND	TSSOP	PW	14	94	TBD	Call TI	Call TI	-40 to 85	LM290 2MT	
LM2902MT/NOPB	ACTIVE	TSSOP	PW	14	94	Green (RoHS & no Sb/Br)	CU SN	Level-1-260C-UNLIM	-40 to 85	LM290 2MT	<a href="#">Samples</a>
LM2902MTX/NOPB	ACTIVE	TSSOP	PW	14	2500	Green (RoHS & no Sb/Br)	CU SN	Level-1-260C-UNLIM	-40 to 85	LM290 2MT	<a href="#">Samples</a>
LM2902MX	NRND	SOIC	D	14	2500	TBD	Call TI	Call TI	-40 to 85	LM2902M	
LM2902MX/NOPB	ACTIVE	SOIC	D	14	2500	Green (RoHS & no Sb/Br)	CU SN   Call TI	Level-1-260C-UNLIM	-40 to 85	LM2902M	<a href="#">Samples</a>
LM2902N/NOPB	ACTIVE	PDIP	NFF	14	25	Green (RoHS & no Sb/Br)	CU SN	Level-1-NA-UNLIM	-40 to 85	LM2902N	<a href="#">Samples</a>
LM324AM	NRND	SOIC	D	14	55	TBD	Call TI	Call TI	0 to 70	LM324AM	
LM324AM/NOPB	ACTIVE	SOIC	D	14	55	Green (RoHS & no Sb/Br)	CU SN   Call TI	Level-1-260C-UNLIM	0 to 70	LM324AM	<a href="#">Samples</a>
LM324AMX	NRND	SOIC	D	14	2500	TBD	Call TI	Call TI	0 to 70	LM324AM	
LM324AMX/NOPB	ACTIVE	SOIC	D	14	2500	Green (RoHS & no Sb/Br)	CU SN   Call TI	Level-1-260C-UNLIM	0 to 70	LM324AM	<a href="#">Samples</a>
LM324AN/NOPB	ACTIVE	PDIP	NFF	14	25	Green (RoHS & no Sb/Br)	CU SN	Level-1-NA-UNLIM	0 to 70	LM324AN	<a href="#">Samples</a>
LM324M	NRND	SOIC	D	14	55	TBD	Call TI	Call TI	0 to 70	LM324M	
LM324M/NOPB	ACTIVE	SOIC	D	14	55	Green (RoHS & no Sb/Br)	CU SN   Call TI	Level-1-260C-UNLIM	0 to 70	LM324M	<a href="#">Samples</a>
LM324MT/NOPB	ACTIVE	TSSOP	PW	14	94	Green (RoHS & no Sb/Br)	CU SN	Level-1-260C-UNLIM	0 to 70	LM324 MT	<a href="#">Samples</a>
LM324MTX/NOPB	ACTIVE	TSSOP	PW	14	2500	Green (RoHS & no Sb/Br)	CU SN	Level-1-260C-UNLIM	0 to 70	LM324 MT	<a href="#">Samples</a>

Orderable Device	Status (1)	Package Type	Package Drawing	Pins	Package Qty	Eco Plan (2)	Lead/Ball Finish (6)	MSL Peak Temp (3)	Op Temp (°C)	Device Marking (4/5)	Samples
LM324MX	NRND	SOIC	D	14	2500	TBD	Call TI	Call TI	0 to 70	LM324M	
LM324MX/NOPB	ACTIVE	SOIC	D	14	2500	Green (RoHS & no Sb/Br)	CU SN   Call TI	Level-1-260C-UNLIM	0 to 70	LM324M	<a href="#">Samples</a>
LM324N/NOPB	ACTIVE	PDIP	NFF	14	25	Green (RoHS & no Sb/Br)	CU SN	Level-1-NA-UNLIM	0 to 70	LM324N	<a href="#">Samples</a>

(1) The marketing status values are defined as follows:

**ACTIVE:** Product device recommended for new designs.

**LIFEBUY:** TI has announced that the device will be discontinued, and a lifetime-buy period is in effect.

**NRND:** Not recommended for new designs. Device is in production to support existing customers, but TI does not recommend using this part in a new design.

**PREVIEW:** Device has been announced but is not in production. Samples may or may not be available.

**OBSOLETE:** TI has discontinued the production of the device.

(2) **RoHS:** TI defines "RoHS" to mean semiconductor products that are compliant with the current EU RoHS requirements for all 10 RoHS substances, including the requirement that RoHS substance do not exceed 0.1% by weight in homogeneous materials. Where designed to be soldered at high temperatures, "RoHS" products are suitable for use in specified lead-free processes. TI may reference these types of products as "Pb-Free".

**RoHS Exempt:** TI defines "RoHS Exempt" to mean products that contain lead but are compliant with EU RoHS pursuant to a specific EU RoHS exemption.

**Green:** TI defines "Green" to mean the content of Chlorine (Cl) and Bromine (Br) based flame retardants meet JS709B low halogen requirements of <=1000ppm threshold. Antimony trioxide based flame retardants must also meet the <=1000ppm threshold requirement.

(3) MSL, Peak Temp. - The Moisture Sensitivity Level rating according to the JEDEC industry standard classifications, and peak solder temperature.

(4) There may be additional marking, which relates to the logo, the lot trace code information, or the environmental category on the device.

(5) Multiple Device Markings will be inside parentheses. Only one Device Marking contained in parentheses and separated by a "~" will appear on a device. If a line is indented then it is a continuation of the previous line and the two combined represent the entire Device Marking for that device.

(6) Lead/Ball Finish - Orderable Devices may have multiple material finish options. Finish options are separated by a vertical ruled line. Lead/Ball Finish values may wrap to two lines if the finish value exceeds the maximum column width.

**Important Information and Disclaimer:**The information provided on this page represents TI's knowledge and belief as of the date that it is provided. TI bases its knowledge and belief on information provided by third parties, and makes no representation or warranty as to the accuracy of such information. Efforts are underway to better integrate information from third parties. TI has taken and continues to take reasonable steps to provide representative and accurate information but may not have conducted destructive testing or chemical analysis on incoming materials and chemicals. TI and TI suppliers consider certain information to be proprietary, and thus CAS numbers and other limited information may not be available for release.

In no event shall TI's liability arising out of such information exceed the total purchase price of the TI part(s) at issue in this document sold by TI to Customer on an annual basis.

**OTHER QUALIFIED VERSIONS OF LM124-N, LM2902-N :**

- Automotive: [LM2902-Q1](#)
- Enhanced Product: [LM2902-EP](#)
- Space: [LM124-SP](#)

## NOTE: Qualified Version Definitions:

- Automotive - Q100 devices qualified for high-reliability automotive applications targeting zero defects
- Enhanced Product - Supports Defense, Aerospace and Medical Applications
- Space - Radiation tolerant, ceramic packaging and qualified for use in Space-based application

**TAPE AND REEL INFORMATION**

**QUADRANT ASSIGNMENTS FOR PIN 1 ORIENTATION IN TAPE**

\*All dimensions are nominal

Device	Package Type	Package Drawing	Pins	SPQ	Reel Diameter (mm)	Reel Width W1 (mm)	A0 (mm)	B0 (mm)	K0 (mm)	P1 (mm)	W (mm)	Pin1 Quadrant
LM2902MTX/NOPB	TSSOP	PW	14	2500	330.0	12.4	6.95	5.6	1.6	8.0	12.0	Q1
LM2902MX	SOIC	D	14	2500	330.0	16.4	6.5	9.35	2.3	8.0	16.0	Q1
LM2902MX/NOPB	SOIC	D	14	2500	330.0	16.4	6.5	9.35	2.3	8.0	16.0	Q1
LM324AMX	SOIC	D	14	2500	330.0	16.4	6.5	9.35	2.3	8.0	16.0	Q1
LM324AMX/NOPB	SOIC	D	14	2500	330.0	16.4	6.5	9.35	2.3	8.0	16.0	Q1
LM324MTX/NOPB	TSSOP	PW	14	2500	330.0	12.4	6.95	5.6	1.6	8.0	12.0	Q1
LM324MX	SOIC	D	14	2500	330.0	16.4	6.5	9.35	2.3	8.0	16.0	Q1
LM324MX/NOPB	SOIC	D	14	2500	330.0	16.4	6.5	9.35	2.3	8.0	16.0	Q1

**TAPE AND REEL BOX DIMENSIONS**

\*All dimensions are nominal

Device	Package Type	Package Drawing	Pins	SPQ	Length (mm)	Width (mm)	Height (mm)
LM2902MTX/NOPB	TSSOP	PW	14	2500	367.0	367.0	35.0
LM2902MX	SOIC	D	14	2500	367.0	367.0	35.0
LM2902MX/NOPB	SOIC	D	14	2500	367.0	367.0	35.0
LM324AMX	SOIC	D	14	2500	367.0	367.0	35.0
LM324AMX/NOPB	SOIC	D	14	2500	367.0	367.0	35.0
LM324MTX/NOPB	TSSOP	PW	14	2500	367.0	367.0	35.0
LM324MX	SOIC	D	14	2500	367.0	367.0	35.0
LM324MX/NOPB	SOIC	D	14	2500	367.0	367.0	35.0

J 14

**GENERIC PACKAGE VIEW**  
**CDIP - 5.08 mm max height**  
CERAMIC DUAL IN LINE PACKAGE



Images above are just a representation of the package family, actual package may vary.  
Refer to the product data sheet for package details.

4040083-5/G

J0014A



# PACKAGE OUTLINE

CDIP - 5.08 mm max height

CERAMIC DUAL IN LINE PACKAGE



4214771/A 05/2017

NOTES:

1. All controlling linear dimensions are in inches. Dimensions in brackets are in millimeters. Any dimension in brackets or parenthesis are for reference only. Dimensioning and tolerancing per ASME Y14.5M.
2. This drawing is subject to change without notice.
3. This package is hermetically sealed with a ceramic lid using glass frit.
4. Index point is provided on cap for terminal identification only and on press ceramic glass frit seal only.
5. Falls within MIL-STD-1835 and GDIP1-T14.

# EXAMPLE BOARD LAYOUT

J0014A

CDIP - 5.08 mm max height

CERAMIC DUAL IN LINE PACKAGE



LAND PATTERN EXAMPLE  
NON-SOLDER MASK DEFINED  
SCALE: 5X





4214771/A 05/2017

D (R-PDSO-G14)

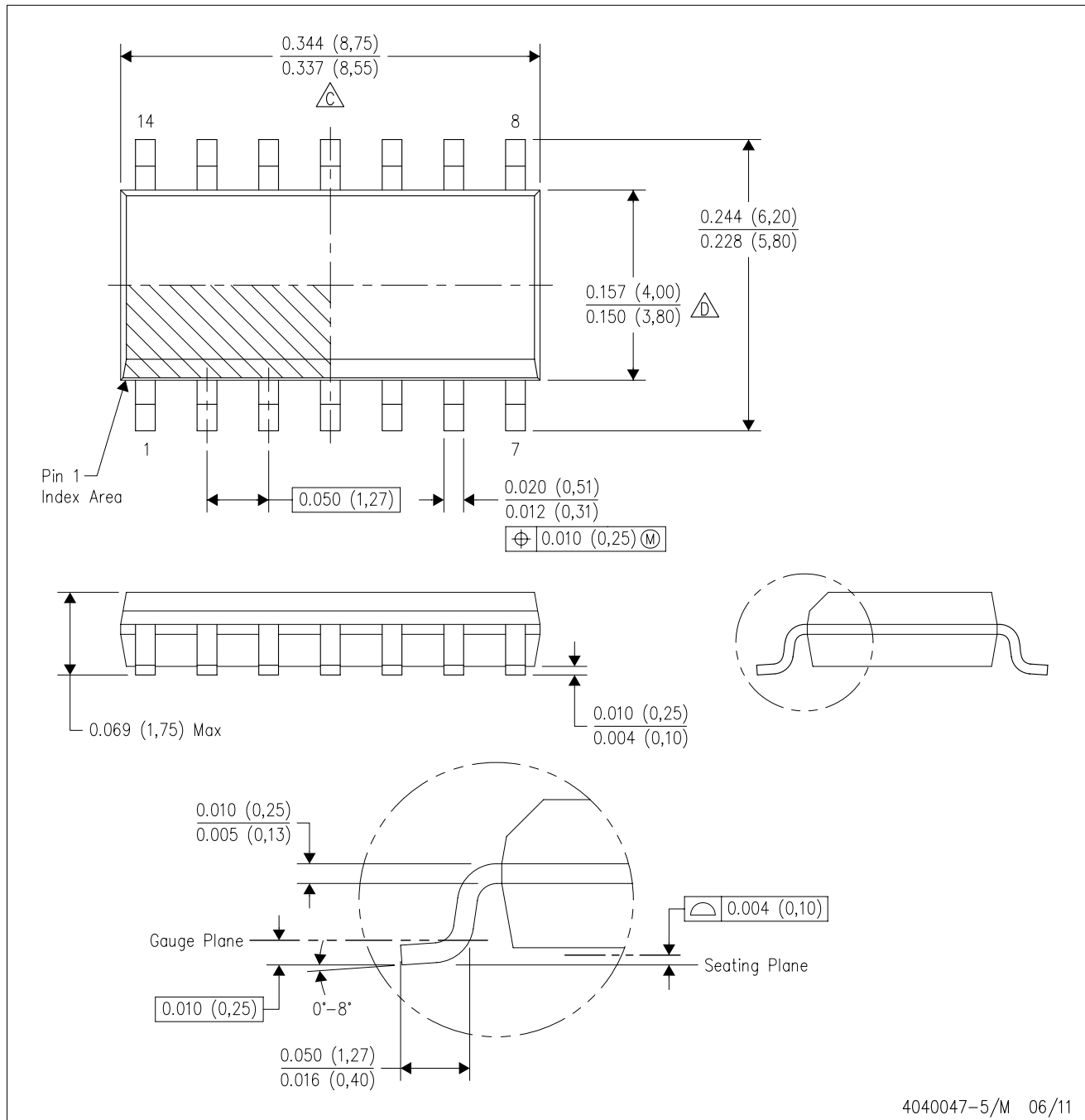
PLASTIC SMALL OUTLINE



- NOTES:
- A. All linear dimensions are in inches (millimeters).
  - B. This drawing is subject to change without notice.
  -  Body length does not include mold flash, protrusions, or gate burrs. Mold flash, protrusions, or gate burrs shall not exceed 0.006 (0,15) each side.
  -  Body width does not include interlead flash. Interlead flash shall not exceed 0.017 (0,43) each side.
  - E. Reference JEDEC MS-012 variation AB.

D (R-PDSO-G14)

PLASTIC SMALL OUTLINE



4211283-3/E 08/12

- NOTES:
- A. All linear dimensions are in millimeters.
  - B. This drawing is subject to change without notice.
  - C. Publication IPC-7351 is recommended for alternate designs.
  - D. Laser cutting apertures with trapezoidal walls and also rounding corners will offer better paste release. Customers should contact their board assembly site for stencil design recommendations. Refer to IPC-7525 for other stencil recommendations.
  - E. Customers should contact their board fabrication site for solder mask tolerances between and around signal pads.



PW (R-PDSO-G14)

PLASTIC SMALL OUTLINE



4211284-2/G 08/15

- NOTES:
- All linear dimensions are in millimeters.
  - This drawing is subject to change without notice.
  - Publication IPC-7351 is recommended for alternate designs.
  - Laser cutting apertures with trapezoidal walls and also rounding corners will offer better paste release. Customers should contact their board assembly site for stencil design recommendations. Refer to IPC-7525 for other stencil recommendations.
  - Customers should contact their board fabrication site for solder mask tolerances between and around signal pads.

N0014A

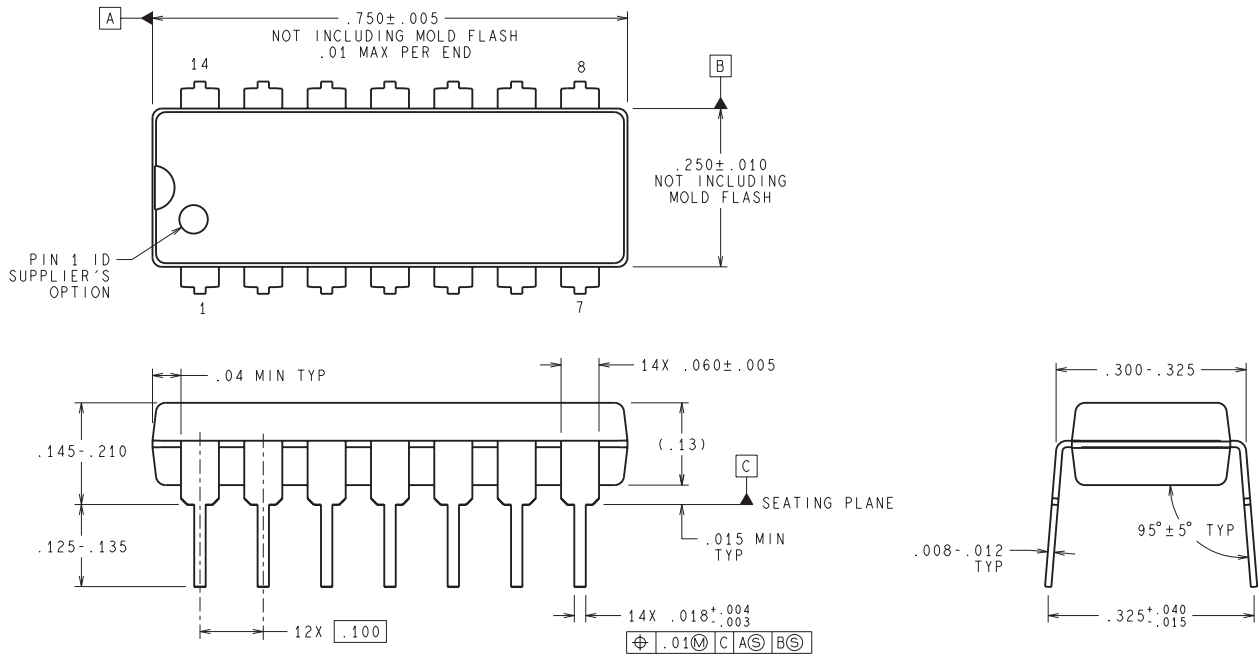

**DIMENSIONS ARE IN INCHES**  
 DIMENSIONS IN ( ) FOR REFERENCE ONLY

N14A (Rev G)

## IMPORTANT NOTICE AND DISCLAIMER

TI PROVIDES TECHNICAL AND RELIABILITY DATA (INCLUDING DATASHEETS), DESIGN RESOURCES (INCLUDING REFERENCE DESIGNS), APPLICATION OR OTHER DESIGN ADVICE, WEB TOOLS, SAFETY INFORMATION, AND OTHER RESOURCES "AS IS" AND WITH ALL FAULTS, AND DISCLAIMS ALL WARRANTIES, EXPRESS AND IMPLIED, INCLUDING WITHOUT LIMITATION ANY IMPLIED WARRANTIES OF MERCHANTABILITY, FITNESS FOR A PARTICULAR PURPOSE OR NON-INFRINGEMENT OF THIRD PARTY INTELLECTUAL PROPERTY RIGHTS.

These resources are intended for skilled developers designing with TI products. You are solely responsible for (1) selecting the appropriate TI products for your application, (2) designing, validating and testing your application, and (3) ensuring your application meets applicable standards, and any other safety, security, or other requirements. These resources are subject to change without notice. TI grants you permission to use these resources only for development of an application that uses the TI products described in the resource. Other reproduction and display of these resources is prohibited. No license is granted to any other TI intellectual property right or to any third party intellectual property right. TI disclaims responsibility for, and you will fully indemnify TI and its representatives against, any claims, damages, costs, losses, and liabilities arising out of your use of these resources.

TI's products are provided subject to TI's Terms of Sale ([www.ti.com/legal/termsofsale.html](http://www.ti.com/legal/termsofsale.html)) or other applicable terms available either on [ti.com](http://ti.com) or provided in conjunction with such TI products. TI's provision of these resources does not expand or otherwise alter TI's applicable warranties or warranty disclaimers for TI products.

Mailing Address: Texas Instruments, Post Office Box 655303, Dallas, Texas 75265  
Copyright © 2019, Texas Instruments Incorporated

## Looking for pricing, stock, or lifecycle information?

Click below to explore more details on WIN SOURCE:

 [View LM324M/NOPB](#) on WIN SOURCE

 [Texas Instruments](#) Information

## Optimize Your Supply Chain with WIN SOURCE Solutions

-  Global Sourcing Solution
-  Obsolete Management
-  Cost Control Management
-  Shortage Management
-  Alternative Solution
-  Excess Inventory Management