

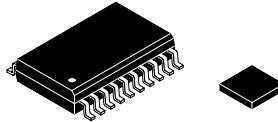

**THE DATASHEET OF  
DRV590ZQCR**





## 1.2-A HIGH-EFFICIENCY PWM POWER DRIVER

### FEATURES

- 1.22-A DC (82% Duty Cycle) Output Current ( $T_J \leq 89^\circ\text{C}$ )
- 1-A DC (100% Duty Cycle) Output Current ( $T_J \leq 89^\circ\text{C}$ )
- Low Supply Voltage Operation from 2.7 V to 5.5 V
- High Efficiency Generates Less Heat
- Over-Temperature Protection
- Short-Circuit Protection
- PowerPAD™ SOIC and 4 × 4 mm MicroStar Junior™ Packages

### APPLICATIONS

- Thermoelectric Cooler (TEC) Driver
- Laser Diode Biasing

### DESCRIPTION

The DRV590 is a high-efficiency power amplifier ideal for driving a wide variety of thermoelectric cooler elements in systems powered from 2.7 V to 5.5 V. PWM operation and low output stage on-resistance significantly decrease power dissipation in the amplifier.

The DRV590 is internally protected against over temperature conditions and current overloads due to short circuits. The over temperature protection activates at a junction temperature of  $190^\circ\text{C}$  and will deactivate once the temperature is less than  $130^\circ\text{C}$ . If the overcurrent circuitry is tripped, the amplifier will automatically reset after 3–5 ms.

The gain of the DRV590 is controlled by two input terminals, GAIN1 and GAIN0. The amplifier may be configured for a gain of 6, 12, 18, and 23.5 dB.

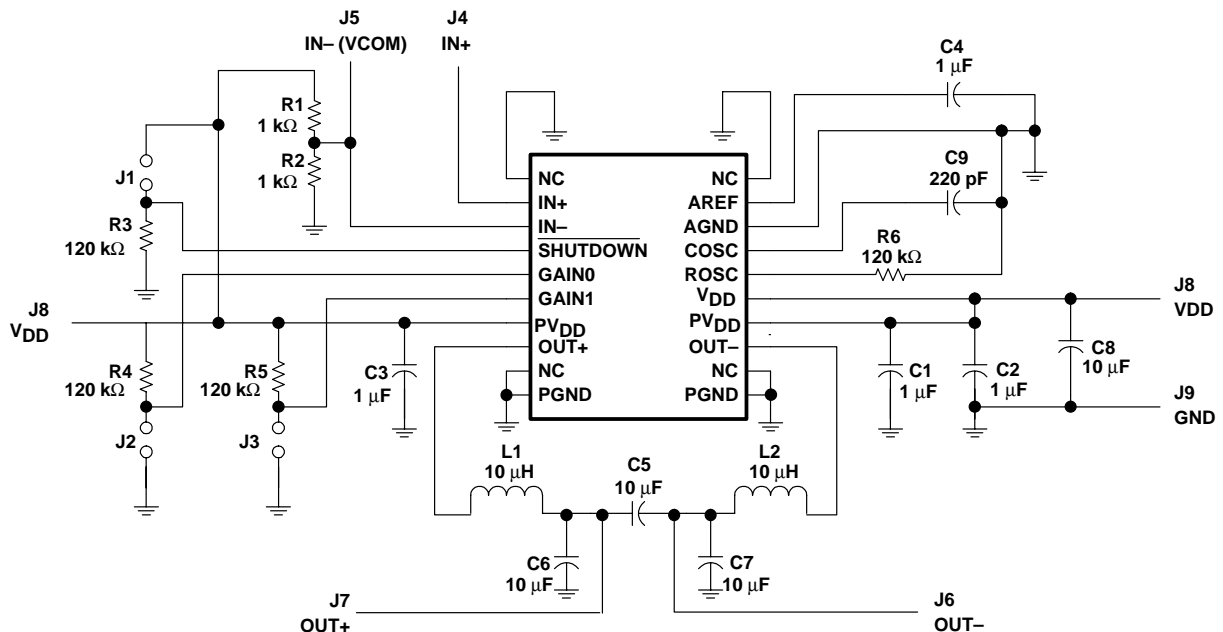

Typical Circuit Schematic for Driving a Thermoelectric Cooler Element



Please be aware that an important notice concerning availability, standard warranty, and use in critical applications of Texas Instruments semiconductor products and disclaimers thereto appears at the end of this data sheet.

PowerPAD and MicroStar Junior are trademarks of Texas Instruments.

This document contains information on products in more than one phase of development. The status of each device is indicated on the page(s) specifying its electrical characteristics.

AVAILABLE OPTIONS

T <sub>A</sub>	PACKAGED DEVICES	
	SOIC (DWP)†	GQC‡
-40°C to 85°C	DRV590DWP	DRV590GQCR

† The PW package is available taped and reeled. To order a taped and reeled part, add the suffix R to the part number (e.g., DRV590PWR).

‡ The GQC package is only available taped and reeled.

DWP PACKAGE (TOP VIEW)

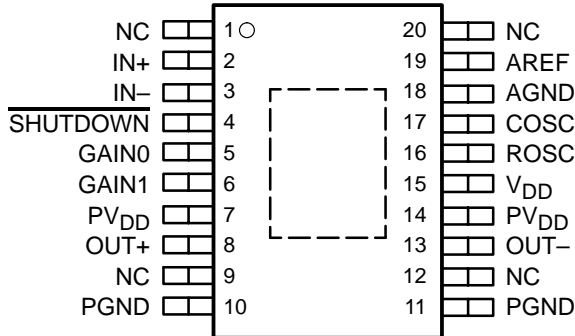

NC – No internal connection

MicroStar Junior™ (GQC) Package (TOP VIEW)

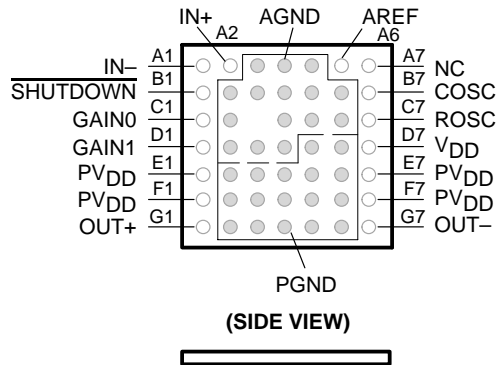

NC – No internal connection

NOTE: The shaded terminals are used for thermal connections to the ground plane.

Terminal Functions

TERMINAL			I/O	DESCRIPTION
NAME	GQC NO.	DWP NO.		
AGND	A3–A5, B2–B6 C2–C6, D2–D4	18	I	Analog ground
AREF	A6	19	O	Connect capacitor to ground for AREF voltage filtering (1 μF).
COSC	B7	17	I	Connect capacitor to ground to set oscillation frequency (220 pF).
GAIN0	C1	5	I	Bit 0 of gain control (TTL logic level)
GAIN1	D1	6	I	Bit 1 of gain control (TTL logic level)
IN–	A1	3	I	Negative differential input
IN+	A2	2	I	Positive differential input
NC	A7	1, 9, 12, 20		Not connected
OUT–	G7	13	O	Negative BTL output
OUT+	G1	8	O	Positive BTL output
PGND	D5–D6, E2–E6 F2–F6, G2–G6	10, 11	I	High-current grounds (2)
PVDD	E1, E7, F1, F7	7, 14	I	High-current power supplies (2)
ROSC	C7	16	I	Connect resistor to ground to set oscillation frequency (120 kΩ).
SHUTDOWN	B1	4	I	Places the amplifier in shutdown mode if a TTL logic low is placed on this terminal, and normal operation if a TTL logic high is placed on this terminal.
VDD	D7	15	I	Analog power supply

**absolute maximum ratings over operating free-air temperature range (unless otherwise noted)†**

Supply voltage, $V_{DD}$ , $PV_{DD}$ .....	-0.3 V to 5.5 V
Input voltage, $V_I$ .....	-0.3 V to $V_{DD} + 0.3$ V
Continuous total power dissipation .....	See Dissipation Rating Table
Operating free-air temperature range, $T_A$ .....	-40°C to 85°C
Operating junction temperature range, $T_J$ .....	-40°C to 150°C
Storage temperature range, $T_{stg}$ .....	-65°C to 150°C
Lead temperature 1,6 mm (1/16 inch) from case for 10 seconds .....	260°C

† Stresses beyond those listed under “absolute maximum ratings” may cause permanent damage to the device. These are stress ratings only, and functional operation of the device at these or any other conditions beyond those indicated under “recommended operating conditions” is not implied. Exposure to absolute-maximum-rated conditions for extended periods may affect device reliability.

**DISSIPATION RATING TABLE**

PACKAGE	$T_A \leq 25^\circ\text{C}$	DERATING FACTOR	$T_A = 70^\circ\text{C}$	$T_A = 85^\circ\text{C}$
GQC	2.61 W	20.9 mW/°C	1.67 W	1.36 W
DWP	3.66 W	29.3 mW/°C	2.34 W	1.9 W

**recommended operating conditions**

	MIN	MAX	UNIT
Supply voltage, $V_{DD}$ , $PV_{DD}$	2.7	5.5	V
High-level input voltage, $V_{IH}$	GAIN0, GAIN1, <u>SHUTDOWN</u>		V
Low-level input voltage, $V_{IL}$	GAIN0, GAIN1, <u>SHUTDOWN</u>		V
Operating free-air temperature, $T_A$	-40	85	°C
Load impedance	1		$\Omega$

**electrical characteristics at specified free-air temperature,  $T_A = 25^\circ\text{C}$  (unless otherwise noted)**

PARAMETER		TEST CONDITIONS	MIN	TYP	MAX	UNIT
$ V_{OS} $	Output offset voltage (measured differentially)	$V_I = 0$ V, $A_V = \text{any gain}$			25	mV
PSRR	Power supply rejection ratio	$PV_{DD} = 4.9$ V to 5.1 V		77		dB
		$PV_{DD} = 3.2$ V to 3.4 V		61		
$ I_{IH} $	High-level input current	$V_I = 3.3$ V			1	$\mu\text{A}$
$ I_{IL} $	Low-level input current	$V_I = 0$ V			1	$\mu\text{A}$
$I_{DD}$	Supply current, no filter			4.5	6.5	mA
$I_{DD(SD)}$	Supply current, shutdown mode	GAIN0, GAIN1, <u>SHUTDOWN</u> = 0 V		0.05	5	$\mu\text{A}$
Gain		GAIN0 = low, GAIN1 = low	5.1	6	6.5	dB
		GAIN0 = high, GAIN1 = low	11	12	12.5	
		GAIN0 = low, GAIN1 = high	17	18	19	
		GAIN0 = high, GAIN1 = high	23	23.5	24	
$f_s$	Switching frequency	Single ended			250	kHz
		Differential	$R_{Osc} = 120$ k $\Omega$ , $C_{Osc} = 220$ pF		500	

operating characteristics,  $T_A = 25^\circ\text{C}$ ,  $R_L = 2 \Omega$ , gain = 6 dB (unless otherwise noted)

PARAMETER	TEST CONDITIONS	MIN	TYP	MAX	UNIT
$I_O$	Maximum output current		1.22		A
PSRR	Power supply rejection ratio	$f = 1 \text{ kHz}$ ,			dB
$Z_I$	Input impedance		>15		$k\Omega$
$V_{ICR}$	Common-mode input voltage range	$PV_{DD} = 5 \text{ V}$	1.2	3.8	V
		$PV_{DD} = 3.3 \text{ V}$	1.2	2.1	
$r_{ds(on)}$	Output on-resistance	$PV_{DD} = 5 \text{ V}$	0.5		$\Omega$
		$PV_{DD} = 3.3 \text{ V}$	0.65		
$\eta$	Efficiency	$PV_{DD} = 5 \text{ V}$	64%		
		$PV_{DD} = 3.3 \text{ V}$	60%		
$V_n$	Integrated noise floor	$f = 10 \text{ Hz to } 5 \text{ kHz}$ , Gain = 6 dB	23		$\mu\text{V rms}$

functional block diagram

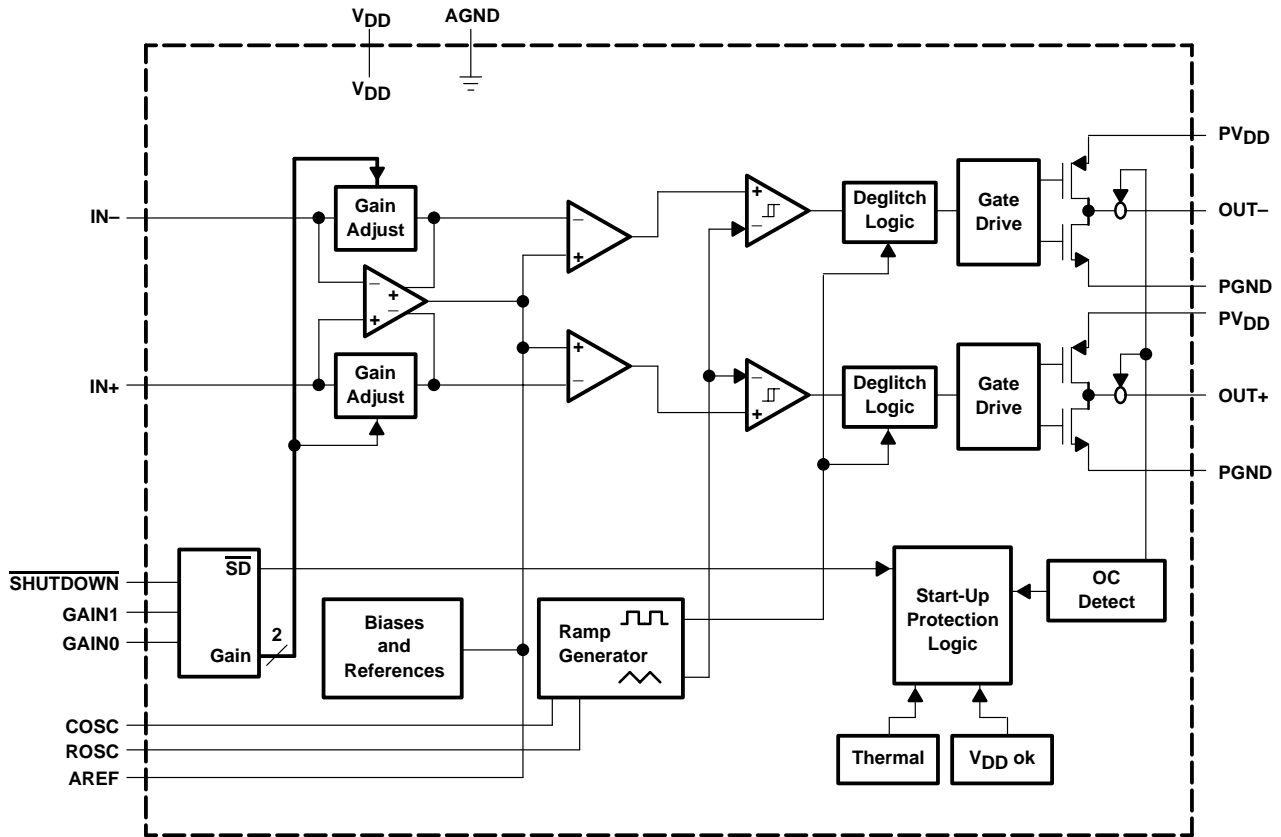

TYPICAL CHARACTERISTICS

Table of Graphs

			FIGURE
Gain and phase		vs Frequency	1
Efficiency		vs Load resistance	2, 3
PSRR	Power supply rejection ratio	vs Frequency	4
$r_{ds(on)}$	Small-signal drain-source on-state resistance	vs Supply voltage	5, 6
		vs Ambient temperature	7, 8
$I_O$	Maximum output current	vs Differential output voltage	9

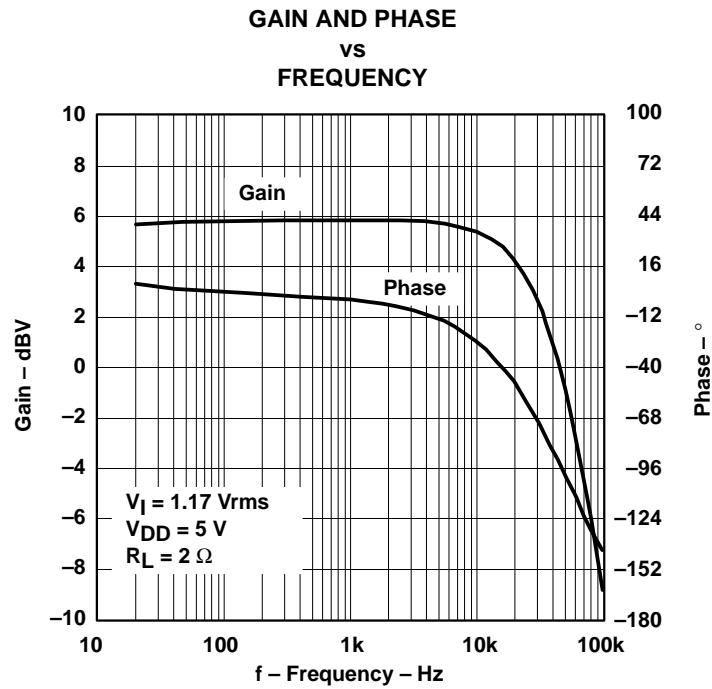

Figure 1

TYPICAL CHARACTERISTICS

EFFICIENCY  
vs  
LOAD RESISTANCE

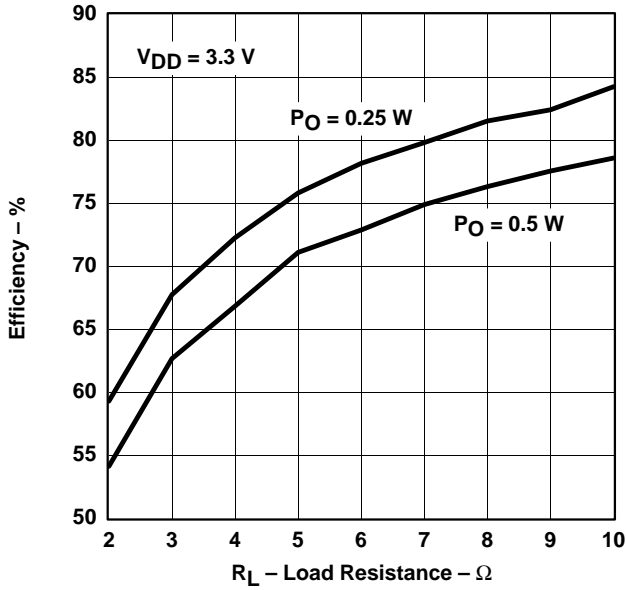

Figure 2

EFFICIENCY  
vs  
LOAD RESISTANCE

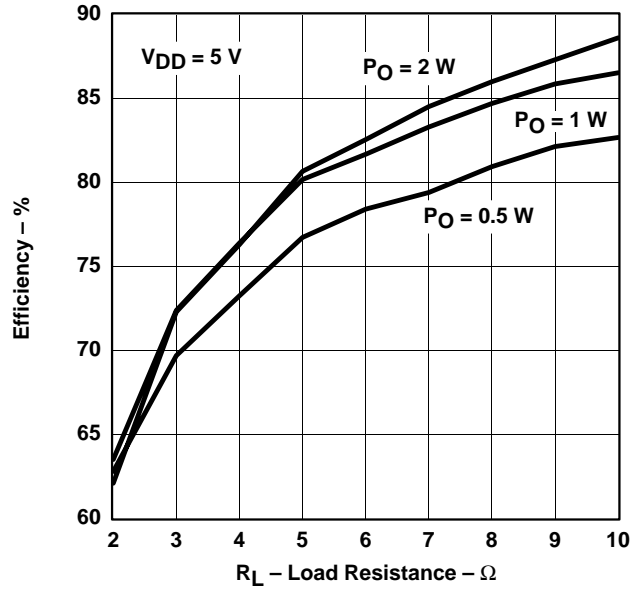

Figure 3

POWER SUPPLY REJECTION RATIO  
vs  
FREQUENCY

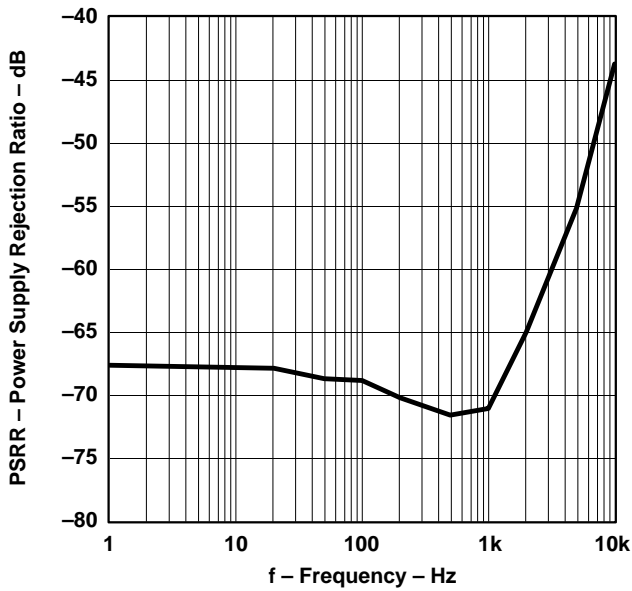

Figure 4

SMALL-SIGNAL DRAIN-SOURCE  
ON-STATE RESISTANCE  
vs  
SUPPLY VOLTAGE

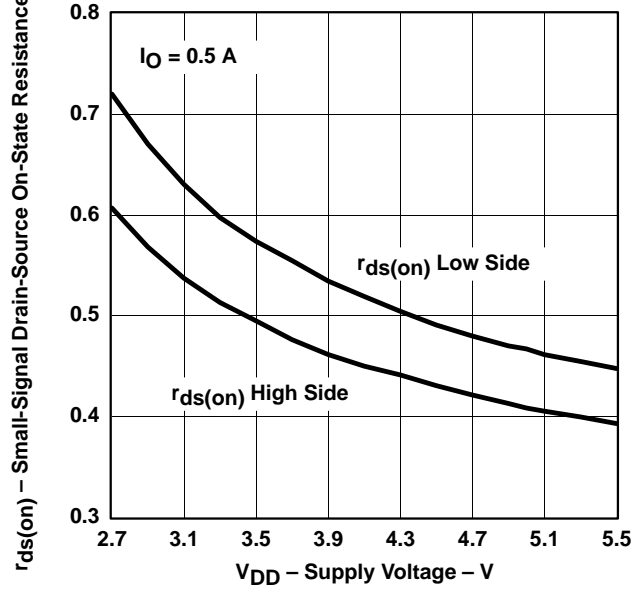

Figure 5

TYPICAL CHARACTERISTICS

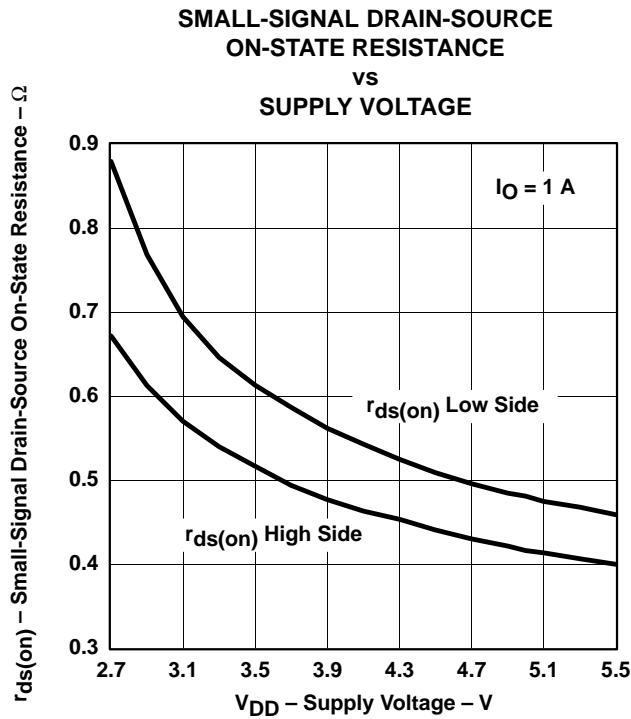

Figure 6

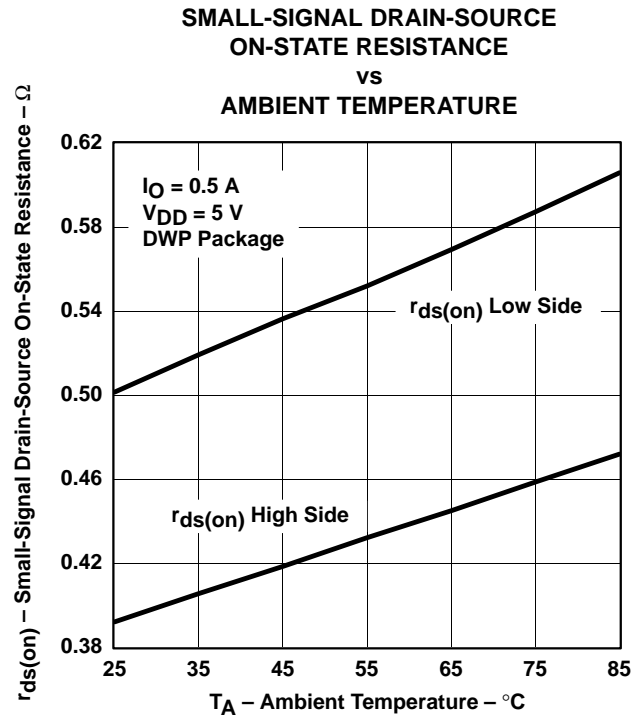

Figure 7

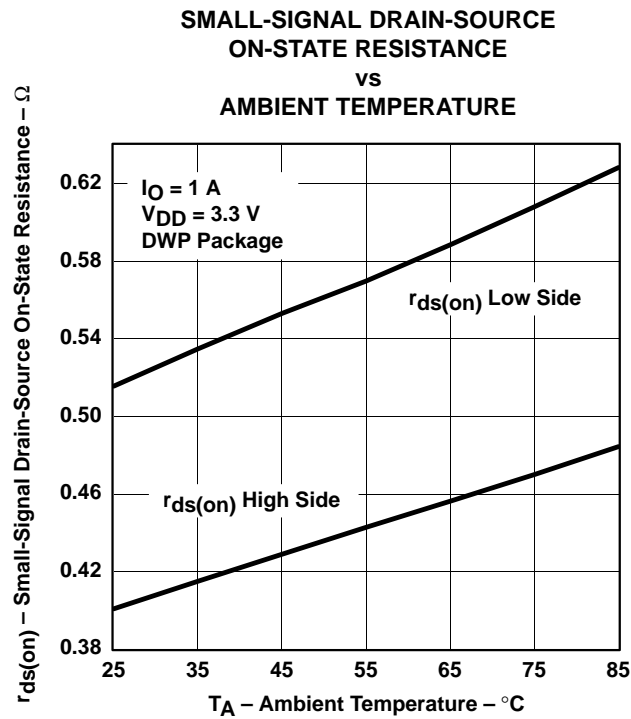

Figure 8

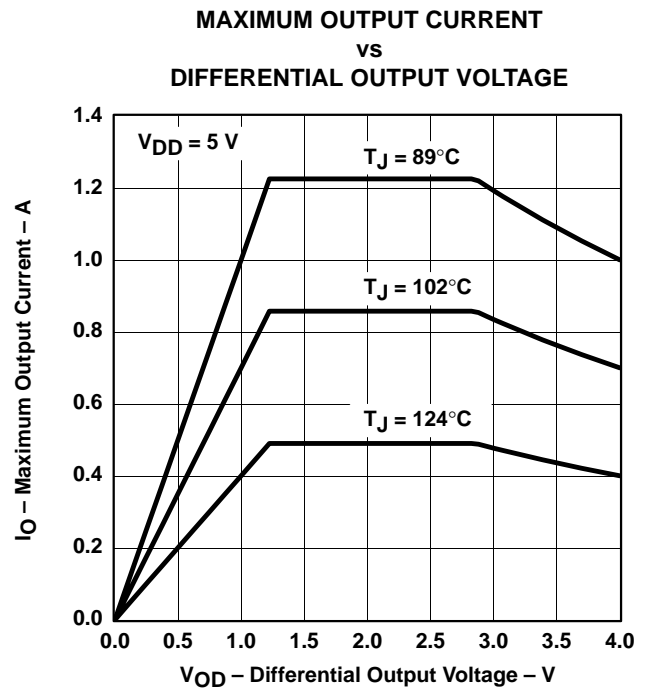
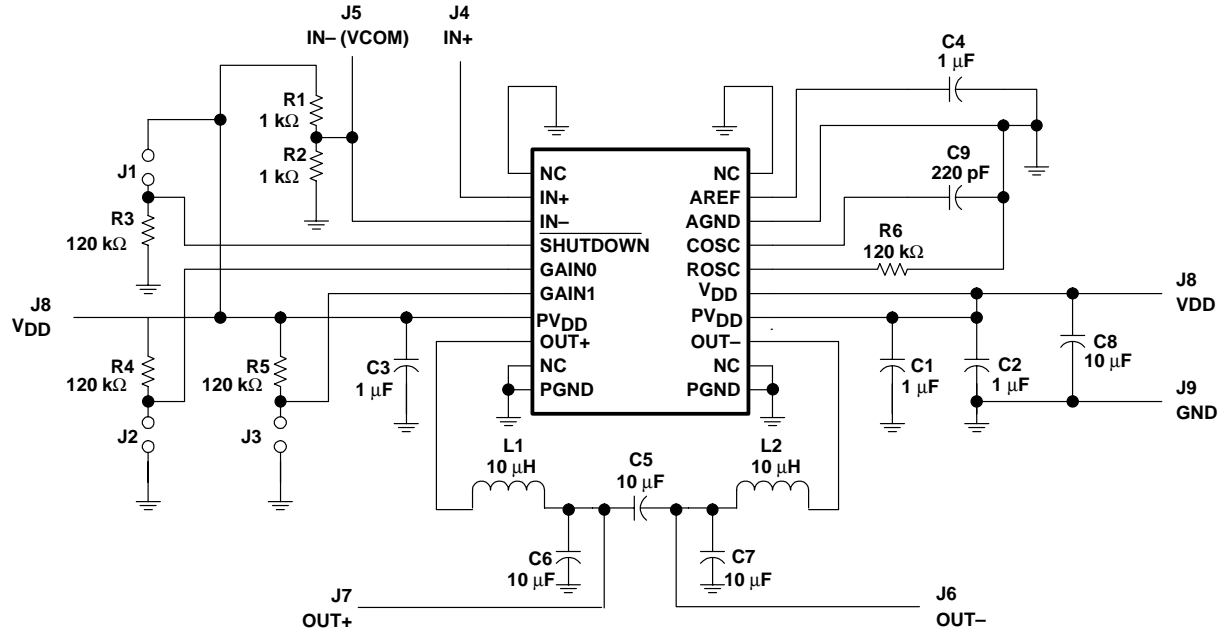

Figure 9

APPLICATION INFORMATION

driving TEC elements

Below is a typical application schematic.



output filter considerations

TEC element manufacturers provide electrical specifications for maximum dc current and maximum output voltage for each particular element. The maximum ripple current, however, is typically only recommended to be less than 10%. The maximum temperature differential across the element decreases as ripple current increases and can be calculated using equation 1.

$$\Delta T = \frac{1}{(1 + N^2) \times \Delta T_{max}} \tag{1}$$

- $\Delta T$  = actual temperature differential
- $\Delta T_{max}$  = maximum temperature differential (specified by manufacturer)
- N = ratio of ripple current to dc current

According to this relationship, a 10% ripple current reduces the maximum temperature differential by 1%. A LC network may be used to filter the current flowing to the TEC to reduce the amount of ripple and, more importantly, protect the rest of the system from any electromagnetic interference (EMI).

APPLICATION INFORMATION

driving TEC elements (continued)

filter component selection

The LC filter may be designed from a couple of different perspectives, both of which may help estimate the overall performance of the system. The filter should be designed for the worst-case conditions during operation, which is typically when the differential output is at 50% duty cycle. The following section serves as a starting point for the design, and any calculations should be confirmed with a prototype circuit.

To simplify the design, half-circuit analysis may also be used. This should only be done if the TEC element is close to the output of the filter. Any filter should always be placed as close to the DRV590 as possible to reduce EMI.

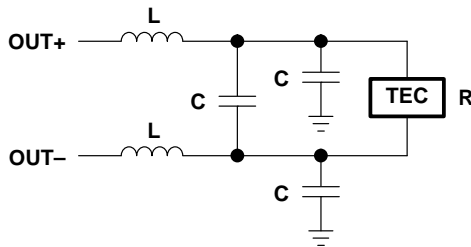

Figure 10. LC Output Filter

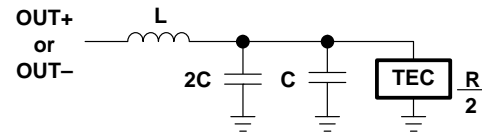

Figure 11. LC Half-Circuit Equivalent

LC filter in the frequency domain

The transfer function for the second order low-pass filter in Figure 10 and Figure 11 is shown in equation 2.

$$H_{LP}(j\omega) = \frac{1}{-\left(\frac{\omega}{\omega_0}\right)^2 + \frac{1}{Q} \frac{j\omega}{\omega_0} + 1} \tag{2}$$

$$\omega_0 = \frac{1}{\sqrt{L \times 3C}}$$

Q = quality factor

$\omega$  = DRV590 differential switching frequency

For the DRV590, the differential output switching frequency is 500 kHz. The resonant frequency for the filter should be chosen to be at least one order of magnitude lower than the switching frequency. Equation 2 may then be simplified to give the following magnitude equation 3. These equations assume the use of the filter in Figure 10, which effectively triples the capacitance.

$$|H_{LP}|_{dB} = -40 \log\left(\frac{f_s}{f_o}\right) \tag{3}$$

$$f_o = \frac{1}{2\pi\sqrt{L \times 3C}}$$

$f_s$  = 500 kHz (DRV590 differential switching frequency)

## APPLICATION INFORMATION

### LC filter in the frequency domain (continued)

If  $L = 10 \mu\text{H}$  and  $C = 10 \mu\text{F}$ , the resonant frequency is 9.2 kHz, which corresponds to –69 dB of attenuation at the 500-kHz switching frequency. For  $V_{\text{DD}} = 5 \text{ V}$ , the amount of ripple voltage at the TEC element will be approximately 1.7 mV.

The average TEC element has a resistance of  $1.5 \Omega$ , so the ripple current through the TEC is approximately 1.13 mA. At the 1-A maximum output current of the DRV590, this 1.13 mA corresponds to 0.113% ripple current, causing less than 0.0001% reduction of the maximum temperature differential of the TEC element (see equation 1).

### LC filter in the time domain

The ripple current of an inductor can be calculated using equation 4. (4)

$$\Delta I_L = \frac{(V_{\text{DD}} - V_{\text{TEC}})DT_s}{L}$$

$D$  = duty cycle (0.5 worst case)

$T_s = 1/f_s = 1/500 \text{ kHz}$

For  $V_{\text{DD}} = 5 \text{ V}$ ,  $V_{\text{TEC}} = 2.5 \text{ V}$ , and  $L = 10 \mu\text{H}$ , the inductor ripple current is 250 mA. To calculate how much of that ripple current will flow through the TEC element, however, the properties of the filter capacitor must be considered.

For relatively small capacitors (less than  $10 \mu\text{F}$ ) with very low equivalent series resistance (ESR, less than  $10 \text{ m}\Omega$ ), such as ceramic capacitors, equation 5 may be used to estimate the ripple voltage on the capacitor due to the change in charge.

$$\Delta V_C = \frac{\pi^2}{2}(1-D)\left(\frac{f_o}{f_s}\right)^2 V_{\text{TEC}} \quad (5)$$

$D$  = duty cycle

$f_s = 500 \text{ kHz}$

$$f_o = \frac{1}{2\pi\sqrt{L \times 3C}}$$

For  $L = 10 \mu\text{H}$  and  $C = 10 \mu\text{F}$ , the cutoff frequency  $f_o = 9.2 \text{ kHz}$ . For a worst case duty cycle of 0.5 and  $V_{\text{TEC}} = 2.5$ , the ripple voltage on the capacitors is 2 mV. The ripple current may be simply calculated by dividing the ripple voltage by the TEC resistance of  $1.5 \Omega$ , resulting in a ripple current through the TEC element of 1.33 mA. Note that this is similar to the value calculated using the frequency domain approach.

For larger capacitors (greater than  $10 \mu\text{F}$ ) with relatively high ESR (greater than  $100 \text{ m}\Omega$ ), such as electrolytic capacitors, the ESR drop dominates over the charging-discharging of the capacitor. Equation 6 can be used to estimate the ripple voltage.

$$\Delta V_C = \Delta I_L \times R_{\text{ESR}} \quad (6)$$

$\Delta I_L$  = inductor ripple current

$R_{\text{ESR}}$  = filter capacitor ESR

For a  $100\text{-}\mu\text{F}$  electrolytic capacitor, an ESR of  $0.1 \Omega$  is common. If the  $10\text{-}\mu\text{H}$  inductor is used, delivering 250 mA of ripple current to the capacitor (as calculated above), then the ripple voltage is 25 mV. This is over ten times that of the  $10\text{-}\mu\text{F}$  ceramic capacitor, as ceramic capacitors typically have negligible ESR.

## APPLICATION INFORMATION

### LC filter in the time domain (continued)

For worst case conditions, the on-resistance of the output transistors has been ignored to give the maximum theoretical ripple current. In reality, the voltage drop across the output transistors will decrease the maximum  $V_O$  as the output current increases. It can be shown using equation 4 that this will decrease the inductor ripple current, and therefore the TEC ripple current.

### general operation

#### oscillator components $R_{OSC}$ and $C_{OSC}$

The onboard ramp generator requires an external resistor and capacitor to set the oscillation frequency. For proper operation, the resistor  $R_{OSC}$  should be 120 k $\Omega$  with 1% tolerance. The capacitor  $C_{OSC}$  should be a ceramic 220 pF with 10% tolerance. Both components should be grounded to AGND, which should be connected to PGND at a single point, typically where the power and ground physically connect to the printed circuit board.

#### AREF capacitor

The AREF terminal is the output of an internal mid-rail voltage regulator used for the on-board oscillator and ramp generator. The regulator may not be used to provide power to any additional circuitry. A 1- $\mu$ F ceramic capacitor must be connected from AREF to AGND for stability (see the *oscillator components  $R_{OSC}$  and  $C_{OSC}$*  section for AGND connection information).

#### gain settings

The differential output voltage may be calculated using equation 7.

$$V_O = V_{OUT+} - V_{OUT-} = A_v(V_{IN+} - V_{IN-}) \quad (7)$$

$A_v$  is the voltage gain, which may be selected by configuring GAIN0 and GAIN1 according to the table below. The input resistance also varies with the gain setting, as shown by the typical values in Table 1. Though these values may vary by up to 30% due to process variations, the gain settings themselves vary little, as they are determined by resistor ratios.

**Table 1. Gain Settings**

GAIN0	GAIN1	AMPLIFIER GAIN (dB, TYPICAL)	INPUT RESISTANCE (k $\Omega$ , TYPICAL)
0	0	6	104
0	1	12	74
1	0	18	44
1	1	23.5	24

## APPLICATION INFORMATION

### general operation (continued)

#### input configuration—differential and single-ended

If a differential input is used, it should be biased around the mid-rail of the DRV590 and must not exceed the common-mode input range of the input stage (see the operating characteristics at the beginning of the data sheet).

The most common configuration employs a single-ended input. The unused input should be tied to the mid-rail, which may be simply accomplished with a resistive voltage divider. For the best performance, the resistor values chosen should be at least an order of magnitude lower than the input resistance of the DRV590 at the selected gain setting. This prevents the bias voltage at the unused input from shifting when the signal input is applied. A small ceramic capacitor should also be placed from the input to ground to filter noise and keep the voltage stable.

#### power supply decoupling

To reduce the effects of high-frequency transients or spikes, a small ceramic capacitor, typically 0.1  $\mu\text{F}$  to 1  $\mu\text{F}$ , should be placed as close to each PVDD pin of the DRV590 as possible. For bulk decoupling, a 10- $\mu\text{F}$  to 100- $\mu\text{F}$  tantalum or aluminum electrolytic capacitor should be placed relatively close to the DRV590.

#### SHUTDOWN operation

The DRV590 includes a shutdown mode that disables the outputs and places the device in a low supply current state. The SHUTDOWN pin may be controlled with a TTL logic signal. When SHUTDOWN is held high, the device operates normally. When SHUTDOWN is held low, the device is placed in shutdown. The SHUTDOWN pin must not be left floating. If the shutdown feature is unused, the pin may simply be connected to  $V_{\text{DD}}$ .

#### power dissipation and maximum ambient temperature

Though the DRV590 is much more efficient than traditional linear solutions, the IR drop across the on-resistance of the output transistors generates some heat in the package, which may be calculated using equation 8.

$$P_{\text{DISS}} = (I_{\text{OUT}})^2 \times r_{\text{ds(on), total}} \quad (8)$$

For example, at the maximum output current of 1.2 A through a total on-resistance of 1  $\Omega$ , the power dissipated in the package is 1.44 W.

The maximum ambient temperature can be calculated using equation 9.

$$T_{\text{A}} = T_{\text{J}}(\theta_{\text{JA}} \times P_{\text{DISS}}) \quad (9)$$

Continuing the example above, the maximum ambient temperature driving 1.2 A without exceeding 89°C junction temperature for a DRV590 in the DWP package (see the *maximum output current vs duty cycle* section) is 39°C.

#### maximum output current vs duty cycle

At 100% duty cycle across the load, the reliability of the DRV590 is degraded if more than 1 A is driven through the outputs. Furthermore, the junction temperature must not exceed 89°C at the maximum output current levels to prevent further degradation. However, as the duty cycle across the load decreases, the maximum allowable output current increases.

Table 2 shows the typical maximum output current, voltage across the load, and junction temperature versus duty cycle. The dissipation and junction temperatures were calculated using equations 8 and 9. The total on-resistance was assumed to be 1  $\Omega$ , the ambient temperature to be 25°C, and the  $\theta_{\text{JA}}$  to be 34.1°C/W.

---

**APPLICATION INFORMATION**

maximum output current vs duty cycle (continued)

**Table 2. Typical Maximum Output Specifications vs Duty Cycle ( $V_{DD} = 5\text{ V}$ )**

DUTY CYCLE	MAX $I_O$ (A)	MAX $V_{LOAD}$ (V)	$P_{DISS}$ (W)	$T_J$ ( $^{\circ}\text{C}$ )
100%	1	4	1	67.6
95%	1.05	3.69	1.11	72.2
90%	1.11	3.38	1.24	77.6
85%	1.17	3.07	1.39	83.9
84%	1.19	3.01	1.42	85.3
83%	1.2	2.94	1.45	86.8
82%	1.22	2.88	1.49	88.3

At duty cycles less than 82%, the power dissipated from the theoretical maximum current flowing through the on-resistance causes the junction temperature to exceed  $89^{\circ}\text{C}$ . See Figure 9 for more details.

**PACKAGING INFORMATION**

Orderable Device	Status (1)	Package Type	Package Drawing	Pins	Package Qty	Eco Plan (2)	Lead/Ball Finish (6)	MSL Peak Temp (3)	Op Temp (°C)	Device Marking (4/5)	Samples
DRV590GQCR	OBSOLETE	BGA MICROSTAR JUNIOR	GQC	48		TBD	Call TI	Call TI	-40 to 85	DRV590	
DRV590ZQCR	OBSOLETE	BGA MICROSTAR JUNIOR	ZQC	48		TBD	Call TI	Call TI	-40 to 85	DRV590	

(1) The marketing status values are defined as follows:

**ACTIVE:** Product device recommended for new designs.

**LIFEBUY:** TI has announced that the device will be discontinued, and a lifetime-buy period is in effect.

**NRND:** Not recommended for new designs. Device is in production to support existing customers, but TI does not recommend using this part in a new design.

**PREVIEW:** Device has been announced but is not in production. Samples may or may not be available.

**OBSOLETE:** TI has discontinued the production of the device.

(2) Eco Plan - The planned eco-friendly classification: Pb-Free (RoHS), Pb-Free (RoHS Exempt), or Green (RoHS & no Sb/Br) - please check <http://www.ti.com/productcontent> for the latest availability information and additional product content details.

**TBD:** The Pb-Free/Green conversion plan has not been defined.

**Pb-Free (RoHS):** TI's terms "Lead-Free" or "Pb-Free" mean semiconductor products that are compatible with the current RoHS requirements for all 6 substances, including the requirement that lead not exceed 0.1% by weight in homogeneous materials. Where designed to be soldered at high temperatures, TI Pb-Free products are suitable for use in specified lead-free processes.

**Pb-Free (RoHS Exempt):** This component has a RoHS exemption for either 1) lead-based flip-chip solder bumps used between the die and package, or 2) lead-based die adhesive used between the die and leadframe. The component is otherwise considered Pb-Free (RoHS compatible) as defined above.

**Green (RoHS & no Sb/Br):** TI defines "Green" to mean Pb-Free (RoHS compatible), and free of Bromine (Br) and Antimony (Sb) based flame retardants (Br or Sb do not exceed 0.1% by weight in homogeneous material)

(3) MSL, Peak Temp. - The Moisture Sensitivity Level rating according to the JEDEC industry standard classifications, and peak solder temperature.

(4) There may be additional marking, which relates to the logo, the lot trace code information, or the environmental category on the device.

(5) Multiple Device Markings will be inside parentheses. Only one Device Marking contained in parentheses and separated by a "~" will appear on a device. If a line is indented then it is a continuation of the previous line and the two combined represent the entire Device Marking for that device.

(6) Lead/Ball Finish - Orderable Devices may have multiple material finish options. Finish options are separated by a vertical ruled line. Lead/Ball Finish values may wrap to two lines if the finish value exceeds the maximum column width.

**Important Information and Disclaimer:** The information provided on this page represents TI's knowledge and belief as of the date that it is provided. TI bases its knowledge and belief on information provided by third parties, and makes no representation or warranty as to the accuracy of such information. Efforts are underway to better integrate information from third parties. TI has taken and

---

continues to take reasonable steps to provide representative and accurate information but may not have conducted destructive testing or chemical analysis on incoming materials and chemicals. TI and TI suppliers consider certain information to be proprietary, and thus CAS numbers and other limited information may not be available for release.

In no event shall TI's liability arising out of such information exceed the total purchase price of the TI part(s) at issue in this document sold by TI to Customer on an annual basis.

ZQC (S-PBGA-N48)

PLASTIC BALL GRID ARRAY

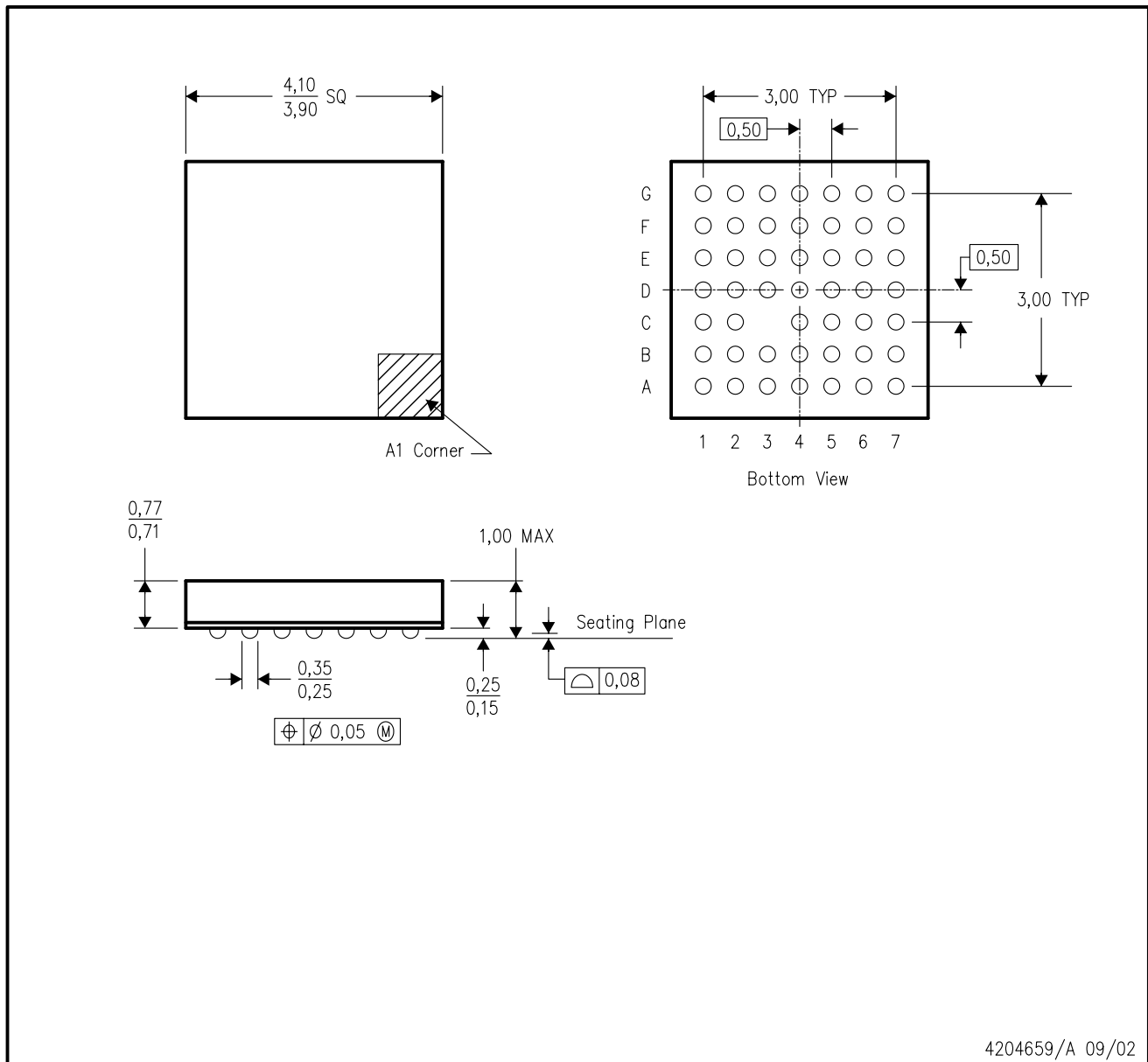

- NOTES:
- A. All linear dimensions are in millimeters.
  - B. This drawing is subject to change without notice.
  - C. MicroStar Junior™ BGA configuration
  - D. Falls within JEDEC MO-225
  - E. This package is lead-free.

MicroStar Junior is a trademark of Texas Instruments.

GQC (S-PBGA-N48)

PLASTIC BALL GRID ARRAY

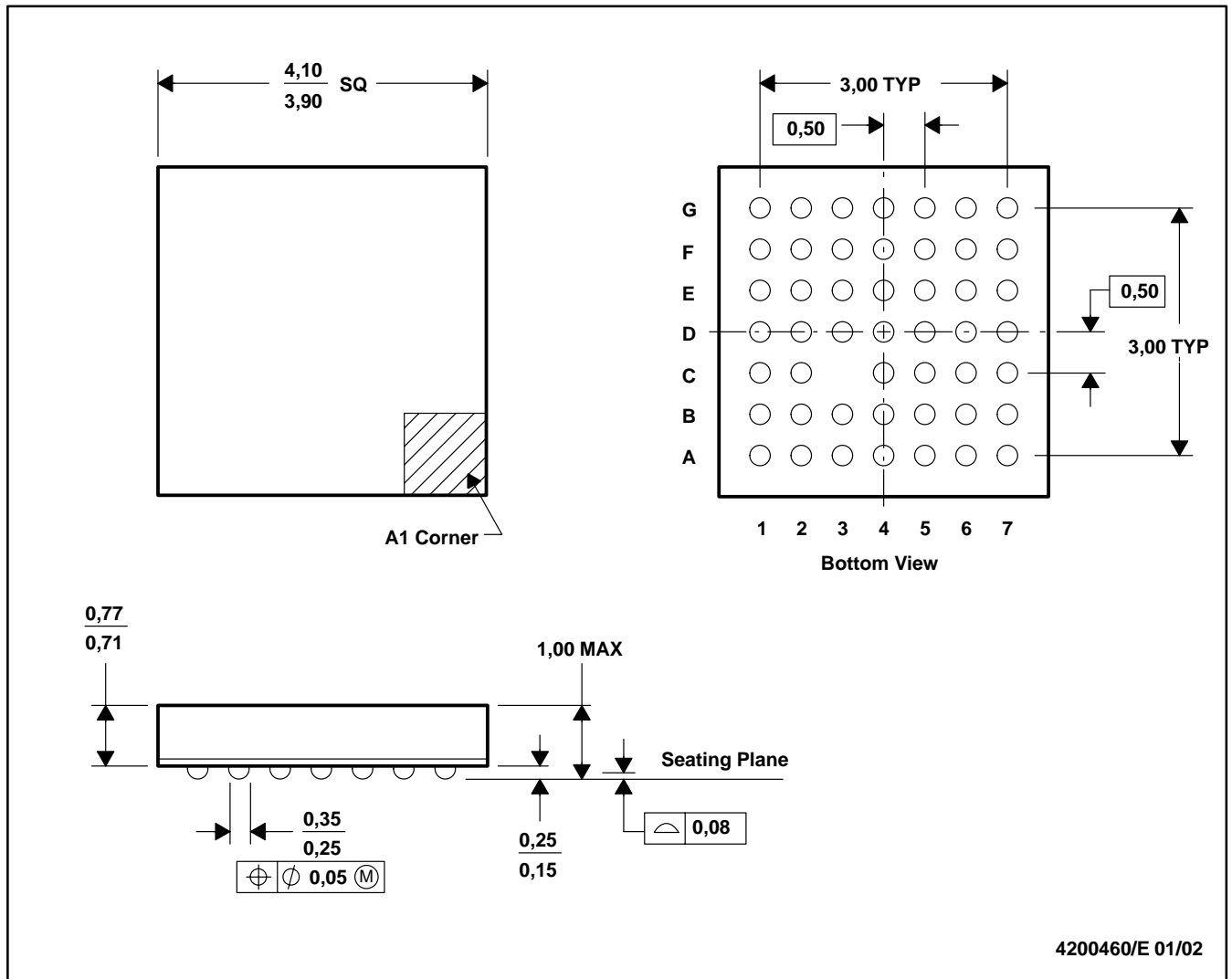

- NOTES: A. All linear dimensions are in millimeters.  
 B. This drawing is subject to change without notice.  
 C. MicroStar Junior™ BGA configuration  
 D. Falls within JEDEC MO-225

MicroStar Junior is a trademark of Texas Instruments.

## IMPORTANT NOTICE

Texas Instruments Incorporated and its subsidiaries (TI) reserve the right to make corrections, enhancements, improvements and other changes to its semiconductor products and services per JESD46, latest issue, and to discontinue any product or service per JESD48, latest issue. Buyers should obtain the latest relevant information before placing orders and should verify that such information is current and complete. All semiconductor products (also referred to herein as "components") are sold subject to TI's terms and conditions of sale supplied at the time of order acknowledgment.

TI warrants performance of its components to the specifications applicable at the time of sale, in accordance with the warranty in TI's terms and conditions of sale of semiconductor products. Testing and other quality control techniques are used to the extent TI deems necessary to support this warranty. Except where mandated by applicable law, testing of all parameters of each component is not necessarily performed.

TI assumes no liability for applications assistance or the design of Buyers' products. Buyers are responsible for their products and applications using TI components. To minimize the risks associated with Buyers' products and applications, Buyers should provide adequate design and operating safeguards.

TI does not warrant or represent that any license, either express or implied, is granted under any patent right, copyright, mask work right, or other intellectual property right relating to any combination, machine, or process in which TI components or services are used. Information published by TI regarding third-party products or services does not constitute a license to use such products or services or a warranty or endorsement thereof. Use of such information may require a license from a third party under the patents or other intellectual property of the third party, or a license from TI under the patents or other intellectual property of TI.

Reproduction of significant portions of TI information in TI data books or data sheets is permissible only if reproduction is without alteration and is accompanied by all associated warranties, conditions, limitations, and notices. TI is not responsible or liable for such altered documentation. Information of third parties may be subject to additional restrictions.

Resale of TI components or services with statements different from or beyond the parameters stated by TI for that component or service voids all express and any implied warranties for the associated TI component or service and is an unfair and deceptive business practice. TI is not responsible or liable for any such statements.

Buyer acknowledges and agrees that it is solely responsible for compliance with all legal, regulatory and safety-related requirements concerning its products, and any use of TI components in its applications, notwithstanding any applications-related information or support that may be provided by TI. Buyer represents and agrees that it has all the necessary expertise to create and implement safeguards which anticipate dangerous consequences of failures, monitor failures and their consequences, lessen the likelihood of failures that might cause harm and take appropriate remedial actions. Buyer will fully indemnify TI and its representatives against any damages arising out of the use of any TI components in safety-critical applications.

In some cases, TI components may be promoted specifically to facilitate safety-related applications. With such components, TI's goal is to help enable customers to design and create their own end-product solutions that meet applicable functional safety standards and requirements. Nonetheless, such components are subject to these terms.

No TI components are authorized for use in FDA Class III (or similar life-critical medical equipment) unless authorized officers of the parties have executed a special agreement specifically governing such use.

Only those TI components which TI has specifically designated as military grade or "enhanced plastic" are designed and intended for use in military/aerospace applications or environments. Buyer acknowledges and agrees that any military or aerospace use of TI components which have **not** been so designated is solely at the Buyer's risk, and that Buyer is solely responsible for compliance with all legal and regulatory requirements in connection with such use.

TI has specifically designated certain components as meeting ISO/TS16949 requirements, mainly for automotive use. In any case of use of non-designated products, TI will not be responsible for any failure to meet ISO/TS16949.

### Products

Audio	<a href="http://www.ti.com/audio">www.ti.com/audio</a>
Amplifiers	<a href="http://amplifier.ti.com">amplifier.ti.com</a>
Data Converters	<a href="http://dataconverter.ti.com">dataconverter.ti.com</a>
DLP® Products	<a href="http://www.dlp.com">www.dlp.com</a>
DSP	<a href="http://dsp.ti.com">dsp.ti.com</a>
Clocks and Timers	<a href="http://www.ti.com/clocks">www.ti.com/clocks</a>
Interface	<a href="http://interface.ti.com">interface.ti.com</a>
Logic	<a href="http://logic.ti.com">logic.ti.com</a>
Power Mgmt	<a href="http://power.ti.com">power.ti.com</a>
Microcontrollers	<a href="http://microcontroller.ti.com">microcontroller.ti.com</a>
RFID	<a href="http://www.ti-rfid.com">www.ti-rfid.com</a>
OMAP Applications Processors	<a href="http://www.ti.com/omap">www.ti.com/omap</a>
Wireless Connectivity	<a href="http://www.ti.com/wirelessconnectivity">www.ti.com/wirelessconnectivity</a>

### Applications

Automotive and Transportation	<a href="http://www.ti.com/automotive">www.ti.com/automotive</a>
Communications and Telecom	<a href="http://www.ti.com/communications">www.ti.com/communications</a>
Computers and Peripherals	<a href="http://www.ti.com/computers">www.ti.com/computers</a>
Consumer Electronics	<a href="http://www.ti.com/consumer-apps">www.ti.com/consumer-apps</a>
Energy and Lighting	<a href="http://www.ti.com/energy">www.ti.com/energy</a>
Industrial	<a href="http://www.ti.com/industrial">www.ti.com/industrial</a>
Medical	<a href="http://www.ti.com/medical">www.ti.com/medical</a>
Security	<a href="http://www.ti.com/security">www.ti.com/security</a>
Space, Avionics and Defense	<a href="http://www.ti.com/space-avionics-defense">www.ti.com/space-avionics-defense</a>
Video and Imaging	<a href="http://www.ti.com/video">www.ti.com/video</a>

### TI E2E Community

[e2e.ti.com](http://e2e.ti.com)

## Looking for pricing, stock, or lifecycle information?

Click below to explore more details on WIN SOURCE:

 [View DRV590ZQCR](#) on WIN SOURCE

 [Texas Instruments](#) Information

## Optimize Your Supply Chain with WIN SOURCE Solutions

-  Global Sourcing Solution
-  Obsolete Management
-  Cost Control Management
-  Shortage Management
-  Alternative Solution
-  Excess Inventory Management