



**THE DATASHEET OF**  
**AK8412**





= PRELIMINARY =

AK8412

1ch/3ch sensor(CIS/CCD) Analog Pre-Processor

### Features

- Processing speed:
  - 1ch : 10M sample/sec
  - 2ch : 5M x 2 sample/sec
  - 3ch : 3.3M x 3 sample/sec
- Input signal level 2Vp-p(typ.)
- Input signal polarity can be selected(CCD/CIS)
- 3ch simultaneously sampling CDS(Correlated Double Sampling) Circuit
- 2 black shading correction modes
  - Pixel rate Black shading correction (9bit,  $\pm 250\text{mV}$ )
  - Offset cancellation (8bit,  $\pm 250\text{mV}$ , 3 independent offset)
- Gain adjustment
  - x 1- x 4 Gain adjustment(8bit, 3 independent gain)
- Total performance(CDS ~ Video ADC)
  - 12bit, No missing codes
  - DNL:0.5LSB(typ.)
  - INL:3.0LSB(typ.)
  - Input reference Noise: 1 LSB<sub>rms</sub>(typ.) (PGA Gain=1)
- 3.3V/5V Digital I/O compatibility
- Serial/Parallel I/F
- Low power consumption : 300mW(typ.)
- 48 pin LQFP(0.5mm pitch, 7 x 7 mold)

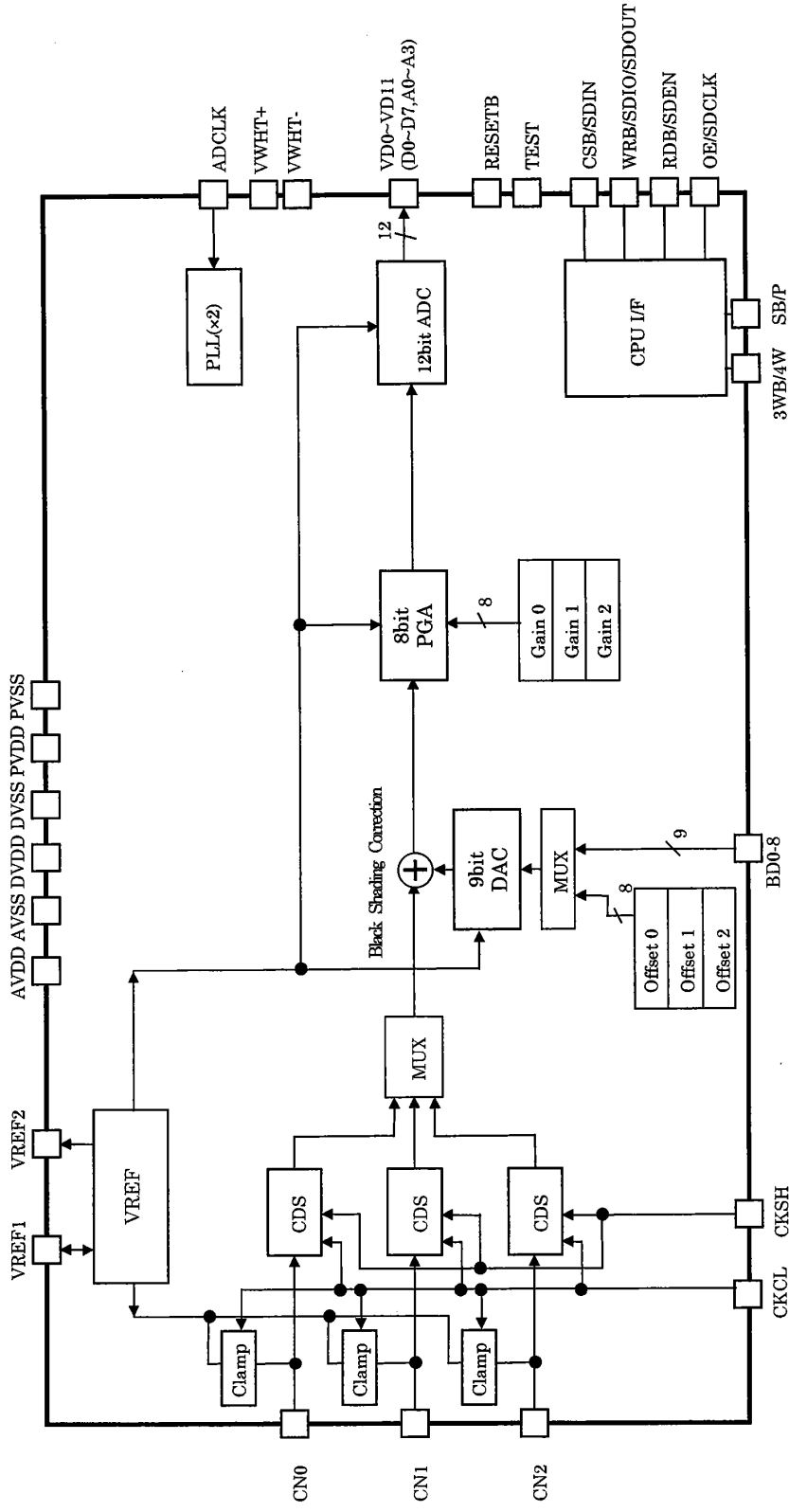

Pin Assignment

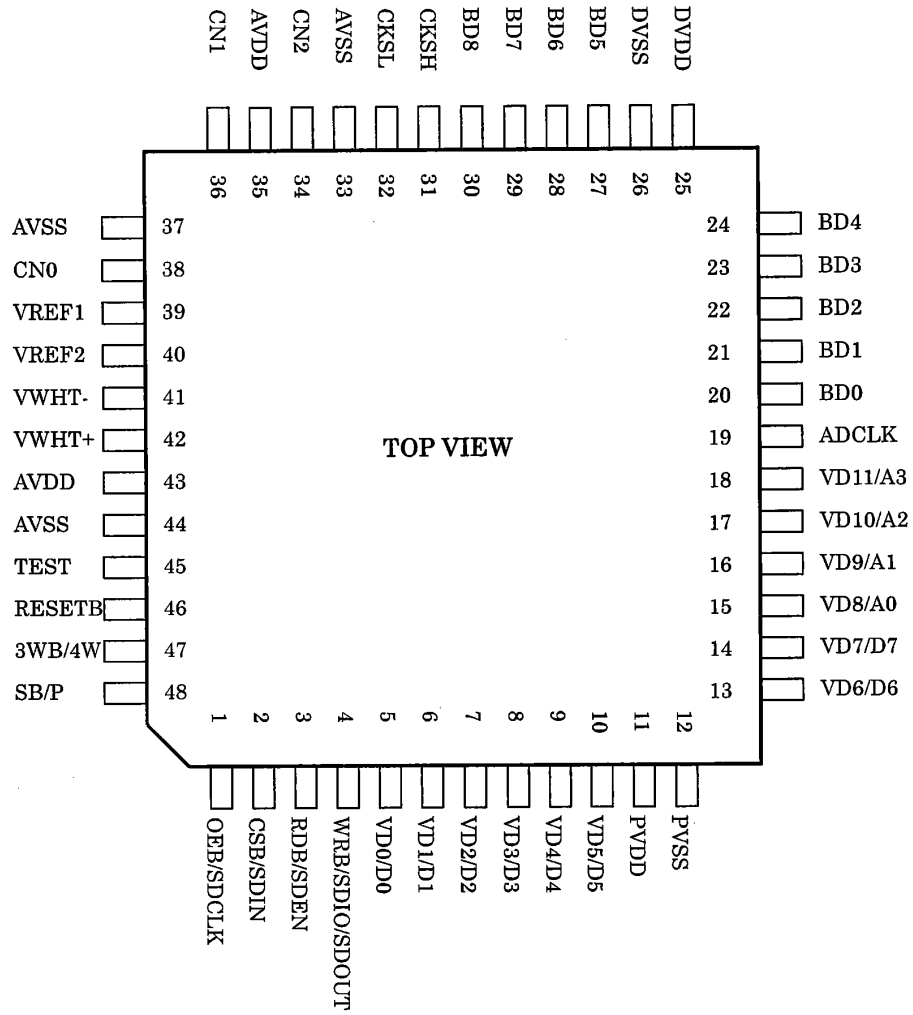

Pin Description
-----------------

Pin name	Pin No	I/O	Function
Shading memory I/F			
BD0-8	20-24 27-30	I	Pixel rate Black shading data, with internal pull-up resistors.
CPU I/F			
OEB/ SDCLK	1	I	Output Enable signal/ Serial clock input
RDB/SDEN	3	I	Read signal(Parallel)/Serial enable(Serial)
WRB/SDIO/ SDOUT	4	I/O	Write signal(Parallel)/Serial data input and output(3 Wire serial)/Serial data output(4 Wire serial)
CSB/SDIN	2	I	Chip select signal(Parallel)/Serial data input(Serial 4 Wire)
3WB/4W	47	I	Serial I/F mode select (L: 3 Wire / H: 4 Wire)
SB/P	48	I	Interface mode select (L: Serial / H: Parallel)
Video output data I/F			
VD0-7/D0-7	5-10 13-14	I/O	SB/P=L Video output data SB/P=H OEB=L Video output data SB/P=H OEB=H CPU data bus
VD8-11/A0-3	15-18	I/O	SB/P=L Video output data SB/P=H OEB=L Video output data SB/P=H OEB=H CPU Address Input
ADCLK	19	I	ADC clock(Clock rate is the same with sensor data rate)
Sampling clock			
CKCL	32	I	Clamp clock
CKSH	31	I	Sample / Hold clock
Other digital pin			
RESETB	46	I	Reset. Please reset after power on. After RESETB rise, wait time for PLL pull-in (1ms) is necessary.
TEST	45	I	Test pin. For normal operation, pull down to DVSS externally.

Pin name		I/O	Function
Analog pin			
CN0	38	I	Sensor signal input In case of using 1ch/2ch/3ch sensor, please input sensor signal to this pin.
CN1	36	I	Sensor signal input In case of using 2ch/3ch sensor, please input sensor signal to this pin.
CN2	34	I	Sensor signal input In case of using 3ch sensor, please input sensor signal to this pin.
VREF1	39	I/O	Internal clamp voltage buffer output(CDS or Clamp mode) / External clamp level input(DC connect mode) When this pin is output, external capacitor is necessary
VREF2	40	O	Reference voltage buffer output. External capacitor is necessary.
VWHT+	41	O	White side reference voltage buffer output for video ADC
VWHT-	42		External capacitor is necessary for each pin.
Power supply			
DVDD	25		Digital supply (5V±5%)
DVSS	26		Digital ground
PVDD	11		Digital Output pad supply (VD0 - VD11, SDIO) (3.15-5.25V)
PVSS	12		Digital Output pad ground (VD0 - VD11, SDIO)
AVDD	35 43		Analog supply (5V±5%)
AVSS	33 37 44		Analog ground

Sensor Interface Mode
-----------------------

AK8412 supports three modes of sensor interface. Please choose most appropriate one according to the sensor.

(1) CDS mode(Correlated Double Sampling)

This mode is for interfacing with CCD, which outputs the reference level at pixel by pixel. AK8412 includes two sets of sample and hold circuit to each channel, one is for sampling the reference level and another is for sampling video signal. As difference between these two levels is treated as actual signal, affect by temperature variation etc. is eliminated. For keeping the input signal dynamic range, a weak clamp circuit, which recovers the droop at pixel by pixel. In this mode please choose 0.1micro farad capacitor.

(2) Clamp mode

This mode is for interfacing with CCD with sample hold and so on, which doesn't output reference level at pixel by pixel. In this mode a strong clamp circuit and only a sample hold circuit for sampling video signal is utilized for each channel. Clamp timing can be defined by the supplied CKCL. In this mode please choose around 1 micro farad capacitor. Please take care of droop voltage and necessary clamp time in this mode.

(3)DC connect mode

This mode is for interfacing with CIS and so on. In this mode only a sample hold circuit for sampling video signal is utilized for each channel. So connect sensor output to signal input pin directly, and pull CKCL pin down to DVSS. And in this mode VREF1 pin is input. Please supply an appropriate reference voltage to this pin.

■ CDS overview

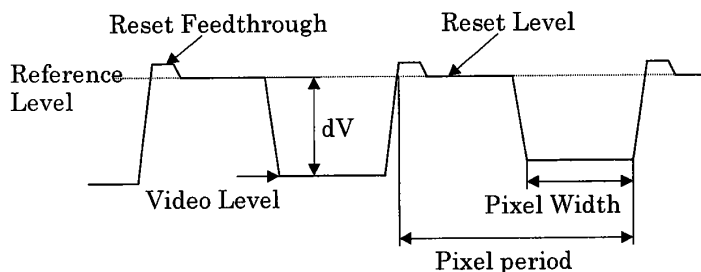

Fig.1 CCD Video Sensor Output Signal

CCD Video Sensor Output Signal is shown in Fig.1. The  $dV$  is the difference Reset Level-Video Level. The  $dV$  defines Sensor input. This is the circuit called CDS(Correlated Double Sampler).  $kT/C$  noise of CCD Video Sensor is eliminated. White noise of CCD Video Sensor is reduced.

CDS circuit diagram and Sample Hold Timing are shown below.

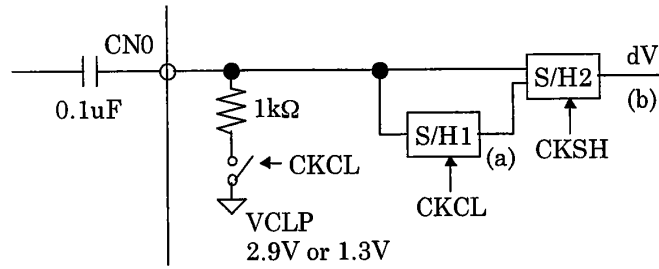

Fig.2 CDS Circuit

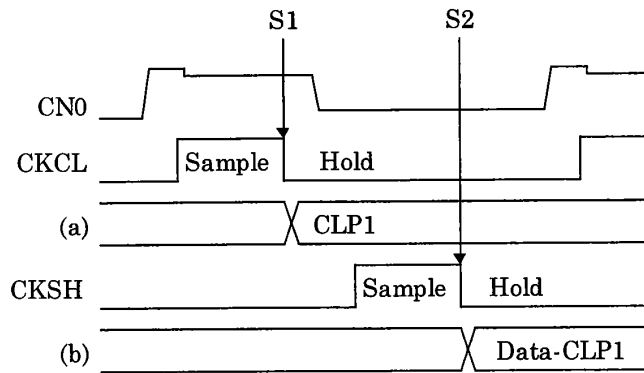

Fig.3 Sample Hold Timing

CDS circuit operation in Fig.2,3 is as follows.

During CKCL is High ,The Reset Level is sampled. At S1(CKCL falling edge),circuit S/H1 hold the Reset Level from CCD Video Sensor.

During CKSH is High ,The Video Level is sampled. At S2(CKSH falling edge)),circuit S/H2 hold the Video Level from CCD Video Sensor.

At this time ,the difference Reset Level-Video Level calculated and it defines Sensor input.

## Registers

Addr.	R/W	init (HEX)	D7	D6	D5	D4	D3	D2	D1	D0
0	R/W	10	Clamp Mode		Black correction range		Signal Polarity	PGA Enable	Black Correction Mode	Black correction range ratio detect Enable
1	R/W	XX	X	X	Processing channel order			Channel Mode select Channel select		
2	R/W	80	offset0(CN0)							
3	R/W	80	offset1(CN1)							
4	R/W	80	offset2(CN2)							
5	R/W	00	PGA gain0(CN0)							
6	R/W	00	PGA gain1(CN1)							
7	R/W	00	PGA gain2(CN2)							
8	R/W	XX	Black correction range ratio							

Register description
----------------------

**R0 register****D7,D6: Clamp Mode**

Select the Clamp mode.

D7	D6	Processing mode	VREF1
0	0	CDS	Internal
0	1	Clamp	Internal
1	0	DC connect (after reset)	External

Typical usage of CDS mode is for CCD, Clamp mode is for CCD with sample and hold circuit, and DC connect is for CIS.

**D5,D4: Black correction range**

Select the black shading correction range.

D5	D4	Correction range
0	0	Clamp level $\pm 100\text{mV}$
0	1	Clamp level $\pm 150\text{mV}$ (after reset)
1	0	Clamp level $\pm 200\text{mV}$
1	1	Clamp level $\pm 250\text{mV}$

**D3: Signal Polarity**

Select the Sensor signal polarity.

0: Negative : Normally CCD (after reset)

1: Positive : Normally CIS

**D2:PGA Enable**

Enable PGA

0: Enable (after reset)

1: Disable (= unity gain)

**D1: Black shading correction Mode**

Select the Black shading Mode.

0: Offset cancel Mode (after reset)

1: Pixel to Pixel correction Mode

**D0: Black correction range ratio detect Enable**

Enable the Black correction range ratio detect mode.

0: Disable (after reset)

1: Enable

This mode is only for users who utilize pixel to pixel type black correction.

## R1 register

D5,D4,D3: Processing channel order

Set the sampling order.

3ch mode

D5	D4	D3	Processing order
0	0	0	CN0→CN1→CN2
0	0	1	CN2→CN0→CN1
0	1	X	CN1→CN2→CN0
1	0	0	CN0→CN2→CN1
1	0	1	CN1→CN0→CN2
1	1	X	CN2→CN1→CN0

2ch mode

D5	D4	D3	Processing order
X	X	0	CN0→CN1
X	X	1	CN1→CN0

(Note) This register is not initialized by reset.

D2,D1,D0: Channel Mode and Enable

Channel Mode select (Normal operation)

D2	D1	D0	Mode
1	1	1	3 Channel
0	1	1	2 Channel
0	0	1	1 Channel

(Note1) Please set only above table value. Another value cause VD0-11 unexpected result.

(Note2) This register is not initialized by reset.

Channel Enable (Black correction range ratio detect mode :R0D0=1)

D2	D1	D0	channel
0	0	1	CN0
0	1	0	CN1
1	0	0	CN2

(Note) This register is not initialized by reset.

At the black correction range ratio detect mode, you can enable only one channel by setting 1 to corresponded bit in this register.

R2,R3,R4 register : offset data

It is possible to set the offset data for each channel. (after reset : 80h)

D7-D0	offset
11111111	-250mV
11111110	:
:	:
10000000	0 mV
:	:
00000000	250mV

Black correction range = ±250mV

**R5,R6,R7 register : PGA gain data**

It is possible to set the gain data for each channel. (after reset : 00h)

Equation between actual gain and set data is as follows.

$$\text{Gain(act)} = 335 / (335 - \text{Gain(set)})$$

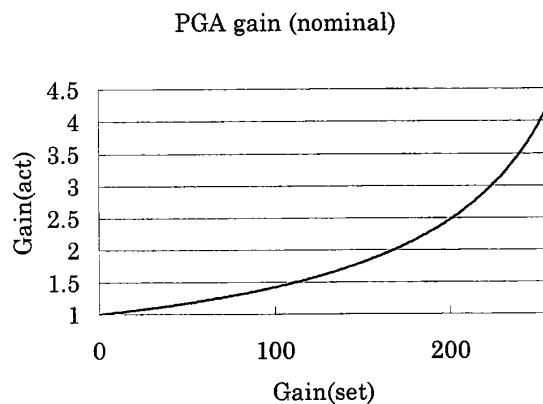
**R8 register : Black correction range ratio**

Black correction range ratio, that is the ratio of black correction circuit range and video ADC range. This data can be utilized for calculating pixel to pixel black shading data, which is automatically set after the black correction range ratio detect mode is executed. This data is no meaning for users who don't use pixel to pixel black shading correction mode.

Black correction mode
-----------------------

AK8412 supports two types of correction mode. One is offset cancel mode, which adjusts only DC offset. Another is pixel to pixel correction mode.

(1) Offset cancel mode

The offset voltage per channel can be adjusted by R2/R3/R4 registers. Please adjust it to appropriate level by monitoring ADC output. Upper 8 bits of Black Correction Circuit are used. Code 80H is nothing dealt with. Code 00H is addition of maximum voltage to input signal. Code FFH is subtraction of maximum voltage from input signal.

(2) Pixel to pixel type correction

In this mode, pixel to pixel correction data is necessary. This section describes an example of detecting it. Please follow to the procedure described below.

[1] Detect of temporary ratio of ADC full scale and Black correction circuit.

- (A) Set PGA gain0 to unity gain(R5=0).
- (B) Set to the Black correction range ratio detect mode enable(R0/D0=1).  
This mode is for calibrating the ratio ADC full scale and Black correction circuit full scale, which will be used calculating pixel to pixel black shading data.
- (C) CNO input is fixed to internal reference level, and 1/2\*(ADC range) is added to internal ADC input automatically.
- (D) This mode is executed automatically by above operations. When this mode will be completed, R0/D0 bit will be reset(0). So after you confirms R0/D0 status, read R8 register and store this data in your system.

[2] Rough black correction data detect

- (A) Set PGA gain0, PGA gain1, and PGA gain2 to unity gain(R5/R6/R7=0).
- (B) Set Black correction mode bit to Offset cancel mode(R0/D1=0).
- (C) Set Black shading data offset0,1,2(R2/3/4) to 00H.
- (D) Scan the document with LED off or scan black reference with LED on, a series of data of 1 line should be data(n)(n=1~n0, n0:pixel count of a sensor).
- (E) Get rough black correction data from following equation.  

$$\text{Rough Black Correction Data}(n) = 511 / (R8 \times 16) \times \text{data}(n)$$

[3] PGA Gain detect

- (A) Set Black correction mode bit to pixel to pixel mode(R0/D1=1).
- (B) Scan white reference document, with supplying Rough black correction data(n) pixel by pixel. By the ADC output, please choose appropriate gains, PGA gain0, PGA gain1, PGA gain2. In two channel mode, PGA gain0 and PGA gain1. In one channel mode, PGA gain0 only.

[4] Detect of ratio of ADC full scale and Black correction circuit by each channel.

- (A) Set PGA gain0 to the detected one(R5).
- (B) Set to the Black correction range ratio detect mode enable(R0/D0=1).  
This mode is for calibrating the ratio ADC full scale and Black correction circuit full scale, which will be used calculating pixel to pixel black shading data.
- (C) CNO inputs are fixed to internal reference level, and  $1/2 \times$  (ADC range) is added to internal ADC input automatically.
- (D) This mode is executed automatically by above operations. When this mode will be completed, R0/D0 bit will be reset(0). So after you confirms R0/D0 status, read R8 register and store this data in your system.
- (E) Depending on channel number is used, please repeat (A)~(D) procedure per channel.  
Get three ratio at maximum depending channel number.

[5] Precise black correction data detect

- (A) Set PGA gain0, PGA gain1, and PGA gain2 to the detected ones(R5/R6/R7).
- (B) Set Black correction mode bit to Offset cancel mode(R0/D1=0).
- (C) Set Black shading data offset0,1,2(R2/3/4) to 00H.
- (D) Scan the document with LED off or scan black reference with LED on, a series of data of 1 line should be data(n)(n=1~n0, n0:pixel count of a sensor) per channel.
- (E) Get Precise black correction data from following equation.  
Precise Black Correction Data(n) =  $511/(R8 \times 16) \times \text{data}(n)$
- (F) In three channel mode, you get three sets of data. In two channels two sets of data. In one channel mode, one set of data. On actual scanning of document, set Black correction mode bit to pixel to pixel mode(R0/D1=1). Scan the document with feeding the calculated black shading data through BD0~BD8 at the defined timing in AC timing specifications.

Note: This way to get pixel to pixel correction data is only an example, does not assure the performance.

Serial I/F Timing

1. 3 Wire serial I/F

(1) Write to AK8412

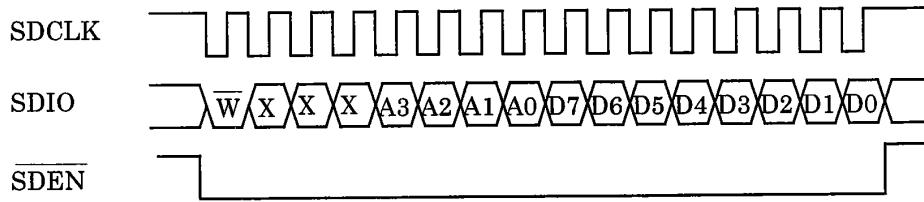

(2) Read from AK8412

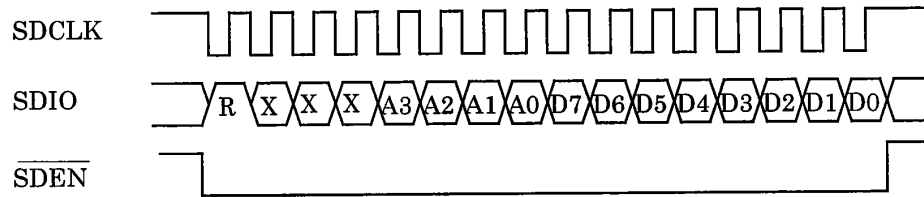

2. 4 Wire serial I/F

(1) Write to AK8412

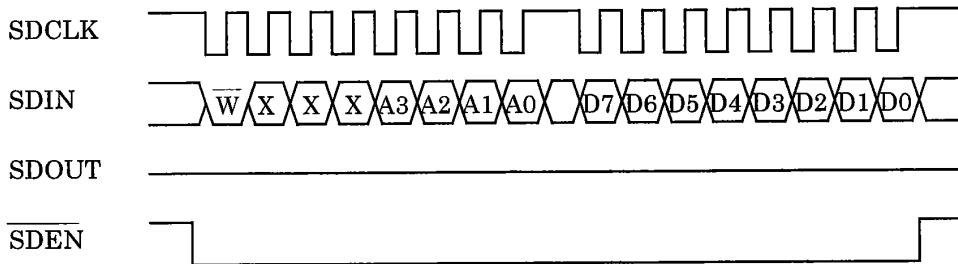

(2) Read from AK8412

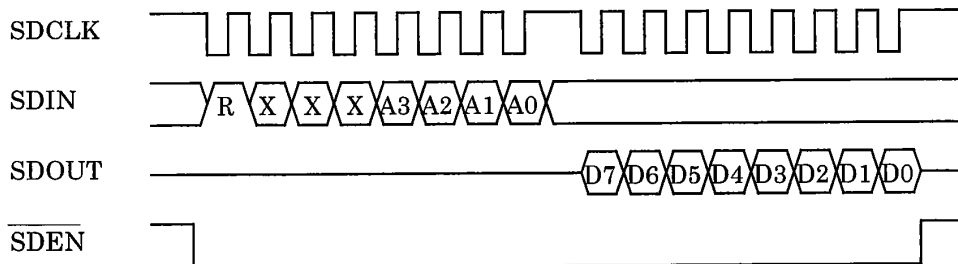

<b>Absolute maximum rating</b>
--------------------------------

All voltage defined to their corresponding ground, AVSS, DVSS, PVSS=0V

Parameters	Sym.	Min.	max.	Unit	Remarks
Supply voltage	VD	-0.3	6.5	V	Must be $V_A \geq V_D$ at all time.
	VP	-0.3	6.5	V	
	VA	-0.3	6.5	V	
Digital applied voltage	VTD	-0.3	$V_D+0.3$	V	
	VTP	-0.3	$V_P+0.3$	V	
Analog applied voltage	VTA	-0.3	$V_A+0.3$	V	
Operating temp.	Ta	0	70	°C	
Storage temp.	Tstg	-55	125	°C	
Soldering temp. and time	Tsol	260°C, 10sec			

<b>Recommended operating condition</b>
--

Parameters	Sym.	min.	typ.	max.	Unit	Remarks
Supply voltage	VD	4.75		5.25	V	Must be $V_A \geq V_D$ at all time.
	VP	3.15		5.25	V	
	VA	4.75		5.25	V	
Operating temp.	Ta	0		70	°C	

<b>Electronic specification</b>
---------------------------------

■ DC specification

(Unless otherwise specified,  $V_D, V_A=5V \pm 5\%$ ,  $V_P=3.15 \sim 5.25V$ ,  $T_a=0 \sim 70^\circ C$ )

Parameters	Sym.	Pins	min.	typ.	Max.	Unit	Conditions
Supply current	ID	DVDD, PVDD		5	10	mA	CDS mode
	IA	AVDD		55	75	mA	No load
Digital	ID	DVDD, PVDD		5	10	mA	DC connect
	IA	AVDD		50	70	mA	Clamp mode
Analog							No load
High level input voltage	VIH	Digital input pins	2.4			V	
Low level input voltage	VIL	Digital input pins			0.8	V	
High level output voltage	VOH	Digital output pins	PVDD -0.5			V	IOH= -0.5mA
Low level output voltage	VOL	Digital output pins			0.5	V	IOL=2mA
Leakage current	IL	Digital input pins	-10		10	μA	VI=DVDD VI=DVSS
	ILPU	BD 0-8	-100		10	μA	

■ Analog specification

(Unless otherwise specified,  $V_D, V_A=5V\pm 5\%$ ,  $V_P=3.15\sim 5.25V$ ,  $T_a=0\sim 70^\circ C$ )

Parameters	min.	typ.	Max.	Unit	Remark
<b>Analog input</b>					
Maximum signal input level	1.8	2.0	2.2	V <sub>p-p</sub>	
Sampling rate	1.5 0.75 0.5		10 5 3.3	Mpix/s	1ch mode 2ch mode 3ch mode
Input capacitance			20	pF	CN0-CN2
Input resistance	1			MΩ	CN0-CN2(When internal clamp switch is OFF) $AVSS+0.5V < V_{IN}$ $< AVDD-0.5V$
<b>Black shading correction circuit</b>					
Correction range		$\pm 100$ $\sim \pm 250$		mV	Programmable by $\pm 50mV$ units
Minimum correction range	$V_{REF1}\pm 50$	$V_{REF1}\pm 100$		mV	range $=\pm 100mV$
	$V_{REF1}\pm 100$	$V_{REF1}\pm 150$		mV	range $=\pm 150mV$
	$V_{REF1}\pm 150$	$V_{REF1}\pm 200$		mV	range $=\pm 200mV$
	$V_{REF1}\pm 200$	$V_{REF1}\pm 250$		mV	range $=\pm 250mV$
Resolution		9		bit	(Note1)
Integral Nonlinearity (by 10bit ADC)		$\pm 1$	$\pm 2$	LSB	range $=\pm 100mV$
		$\pm 2$	$\pm 4$	LSB	range $=\pm 150mV$
ADCLK $\leq 7.5MHz$		$\pm 3$	$\pm 6$	LSB	range $=\pm 200mV$
		$\pm 4$	$\pm 8$	LSB	range $=\pm 250mV$
ADCLK=7.5~10MHz		$\pm 5$	$\pm 10$	LSB	range $=\pm 100mV$
		$\pm 15$	$\pm 30$	LSB	range $=\pm 150mV$
		$\pm 25$	$\pm 50$	LSB	range $=\pm 200mV$
		$\pm 35$	$\pm 70$	LSB	range $=\pm 250mV$
<b>Voltage reference</b>					
VREF1 output voltage	1.15	1.3	1.45	V	Signal polarity: Positive
	2.6	2.9	3.2	V	Signal polarity: Negative
VREF1 input voltage	0		1.6	V	Signal polarity: Positive
	2		3.6	V	Signal polarity: Negative
VREF2 voltage	1.95	2.2	2.45	V	
VWHT+ voltage	2.45	2.7	2.95	V	
VWHT- voltage	1.45	1.7	1.95	V	
<b>Clamp circuit</b>					
Clamp Switch ON resistance			100	Ω	Clamp mode Analog input=2.0V
			1.5	kΩ	CDS mode
<b>Sample and hold circuit</b>					
Droop voltage			10	mV	Clamp mode C=2uF MCLK=10MHz VCLP-2V 8000pixels
Residual offset voltage after clamp recovery			20	mV	Clamp mode C=2uF MCLK=10MHz VCLP-2V 8000pixels Recovery clamp=100uS (Note2)

(Unless otherwise specified, VD,VA=5V±5%,VP=3.15~5.25V, Ta=0~70°C)

Parameters	min.	typ.	Max.	Unit	Remark
<b>PGA circuit</b>					
Resolution		8		bit	(Note3)
Minimum Gain range	0.95	1.0	1.05		
Maximum Gain range	4.0	4.2	4.4		
<b>Video ADC</b>					
Resolution		12		bit	No code missing
Maximum signal input level	1.8	2.0	2.2	Vp-p	Maximum code appears in this range.
Minimum signal input level	VREF1-50		VREF1+50	mV	Minimum code appears in this range.
Integral Nonlinearity (INL)		±3.0	±6.0	LSB	
Differential Nonlinearity (DNL)		±0.5	±1.0	LSB	
<b>Noise and Crosstalk</b>					
Total Output Noise PGA min		1		LSBrms	CDS mode
Total Output Noise PGA max		1.5		LSBrms	CDS mode
Channel-Channel Crosstalk (Dynamic)		0.5		LSB	ADCLK=10MHz Sinusoidal Input Signal 200kHz,1.4Vpp
Channel-Channel Crosstalk (Static)			8	LSB	(Note4)
<b>PLL</b>					
pull in time			1	ms	

(Note1) The monotonicity of code at a multiple of 8 is degraded. Please don't use the codes, which are multiple of 8. The monotonicity of code except a multiple of 8 is guaranteed.

(Note2) Not production tested. Parameters guaranteed by design and characterization.

(Note3) The monotonicity of code 127 and 128 is degraded. Please don't use these two codes.

(Note4) Input of measured channel is 0Vpp or 2Vpp. Channel-Channel Crosstalk (Static) is the difference between ADC code with the other two channel inputs at 0Vpp and ADC codes with the other channel inputs at 2Vpp.

■ Level Diagram

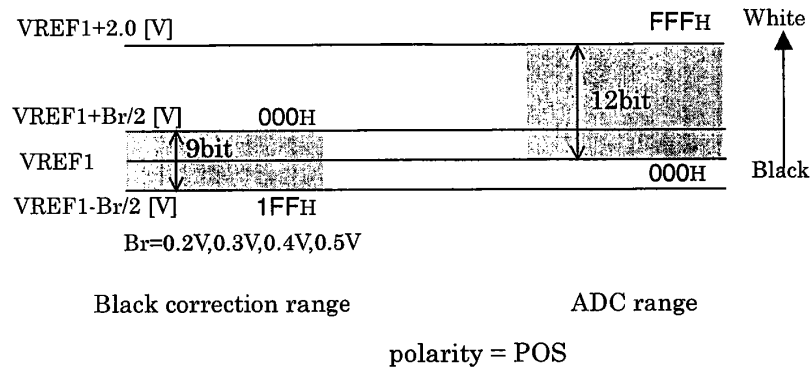
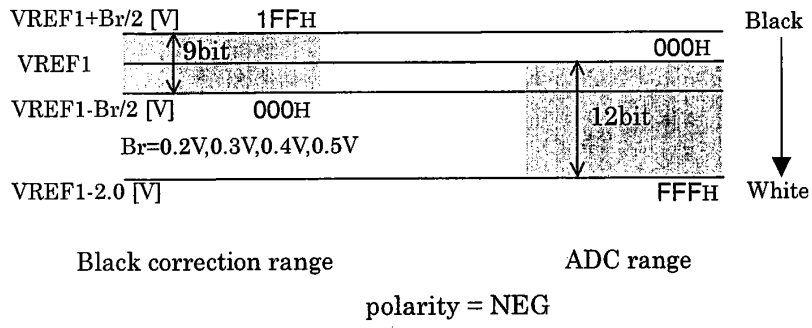

■ Digital AC timing

(Unless otherwise specified, VD,VA=5V±5%, VP=3.15~5.25V, Ta=0~70°C)

No.	Parameters	Pins	min.	typ.	max.	unit	Condition
1	ADCLK cycle time(T)	ADCLK	100			ns	
2	ADCLK low level width	ADCLK	30			ns	
3	ADCLK high level width	ADCLK	30			ns	
4	CKCL pulse width	CKCL	25			ns	
5	CKSH cycle time	CKCL CKSH	300			ns	3ch mode
			200			ns	2ch mode
			100			ns	1ch mode
6	CKSH pulse width	CKSH	35			ns	
7	CKSH↑delay time (to CKCL↓)	CKSH	0			ns	
8	CKSH set up time (to ADCLK↑)	CKSH	25		T-10	ns	
9	CKSH hold time (to ADCLK↑)	CKSH	10			ns	
10	CN0-2 set up time (to CKCL↓)	CN0-2	25			ns	
11	CN0-2 hold time (to CKCL↓)	CN0-2	10			ns	
12	CN0-2 set up time (to ADCLK↑)	CN0-2	25			ns	
13	CN0-2 hold time (to ADCLK↑)	CN0-2	10			ns	
14	CKCL delay time (to CKSH↓)	CKCL	0			ns	
15	VD0-VD11 delay time (to ADCLK↑)	VD0- VD11			35	ns	C=20pF
16	BD0-8 set up time (to ADCLK↑)	BD0-8	20		T -20	ns	
17	BD0-8 hold time (to ADCLK↑)	BD0-8	20		T -20	ns	

(Unless otherwise specified, VD,VA=5V±5%, VP=3.15~5.25V, Ta=0~70°C)

No.	Parameters	Pins	min.	typ.	Max.	unit	Condition
18	/CS set up time (to /WR↓,/RD↓)	/CS	20			ns	
19	/CS hold time (to /WR↑,/RD↑)	/CS	0			ns	
20	A0-A3 set up time (to /WR↓,/RD↓)	A0-A3	20			ns	
21	A0-A3 hold time (to /WR↑,/RD↑)	A0-A3	0			ns	
22	/WR pulse width	/WR	20			ns	
23	D0-D7 set up time (to /WR↑)	D0-D7	20			ns	
24	D0-D7 hold time (to /WR↑)	D0-D7	0			ns	
25	/RD pulse width	/RD	20			ns	
26	D0-D7 delay time (to /RD↓)	D0-D7			30	ns	C=20pF
27	D0-D7 hold time (to /RD↑)	D0-D7	0			ns	
28	VD0-VD11→Hi-Z delay time(to /OE↑)	VD0- VD11			25	ns	
29	VD0-VD11 Hi-Z→output time(to /OE↓)	VD0- VD11			25	ns	
30	/OE set up time (to /WR↓, /RD↓)	/OE	20			ns	
31	/OE hold time (to /WR↑,/RD↑)	/OE	0			ns	

(Unless otherwise specified, VD,VA=5V±5%, VP=3.15~5.25V, Ta=0~70°C)

No.	Parameters	Pins	min.	typ.	Max.	unit	Condition
32	SDCLK cycle time	SDCLK	80			ns	
33	SDCLK low level width	SDCLK	40			ns	
34	SDCLK high level width	SDCLK	40			ns	
35	serial access cycle time	SDCLK	1360			ns	
36	SDIO,SDIN set up time (to SDCLK↑)	SDIO SDIN	20			ns	
37	SDIO,SDIN hold time (to SDCLK↑)	SDIO SDIN	20			ns	
38	/SDEN set up time (to SDCLK↓)	/SDEN	40			ns	
39	/SDEN hold time (to SDCLK↑)	/SDEN	40			ns	
40	/SDEN high level width	/SDEN	40			ns	
41	SDIO,SDOUT delay time (to SDCLK↓)	SDIO SDOUT			30	ns	C=20pF
42	SDIO,SDOUT hold time (to /SDEN↑)	SDIO SDOUT	0			ns	C=20pF
43	/RESET	/RESET	20			ns	

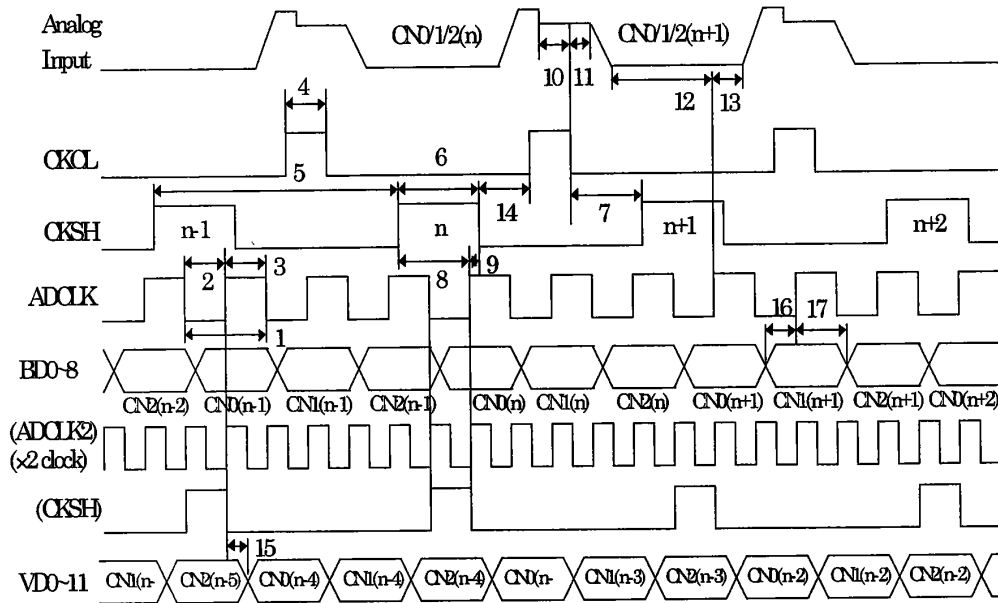

Fig.4 3Channel Mode (CDS)

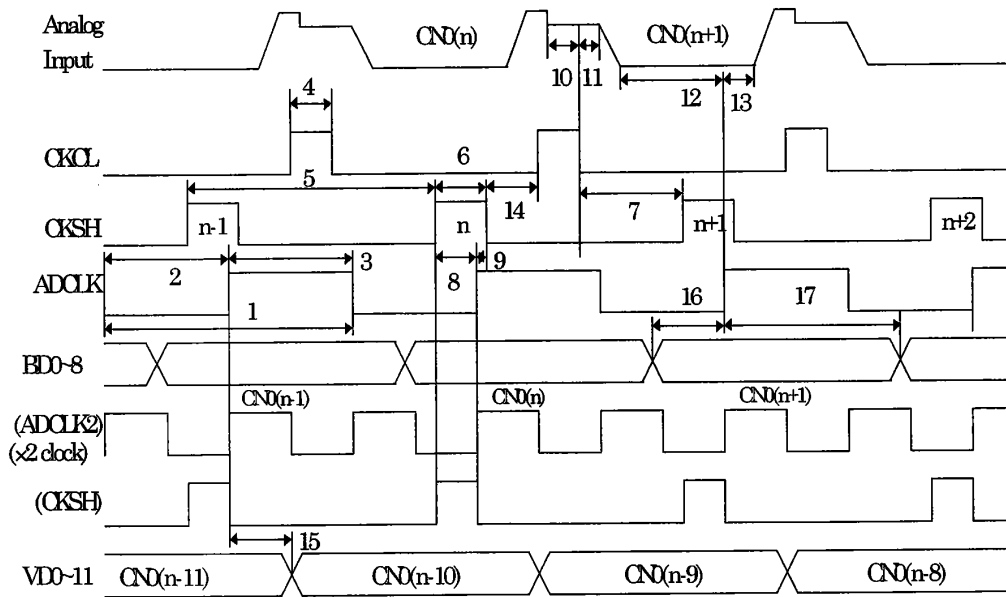

Fig.5 1Channel Mode (CDS)

(1)CDS mode timing

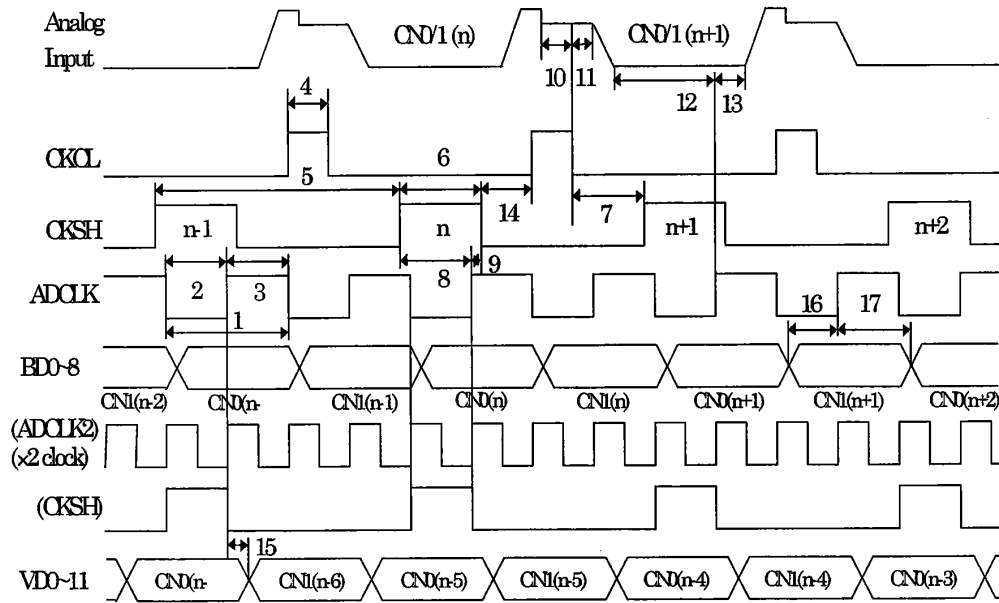

Fig.6 2Channel Mode (CDS)

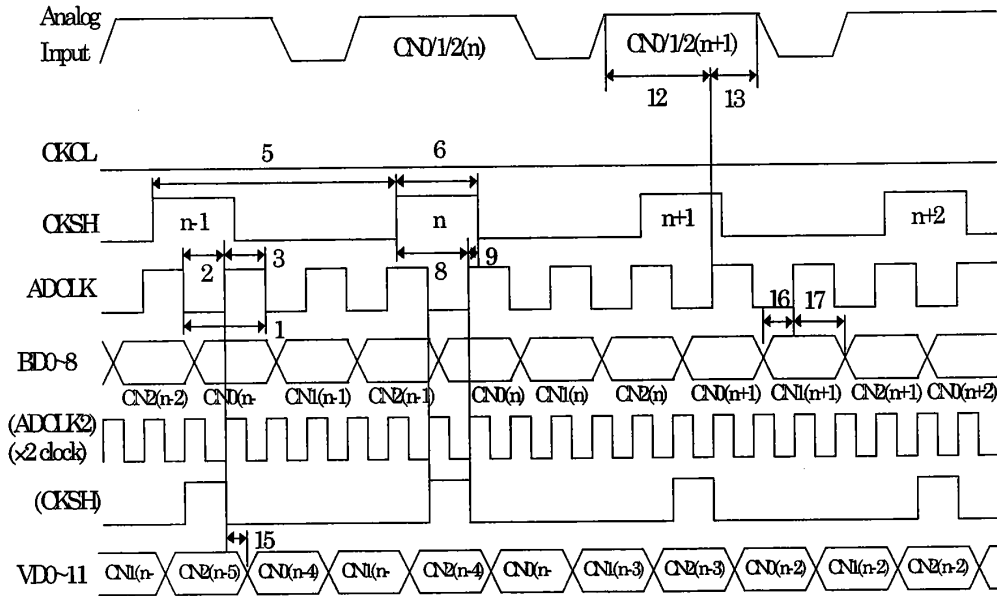

Fig.7 3Channel Mode (DC connect)

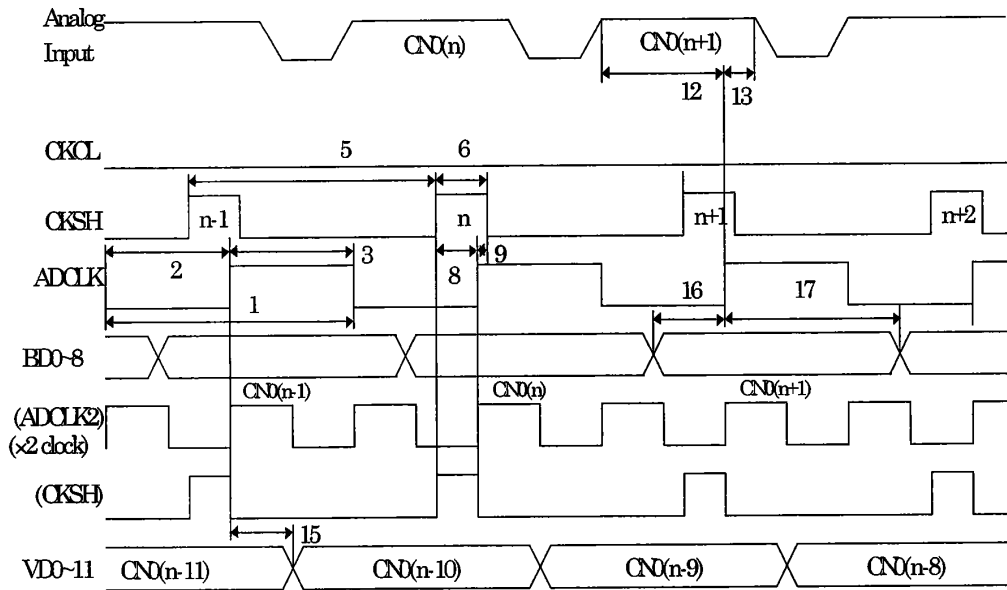

Fig. 8 1Channel Mode (DC connect)

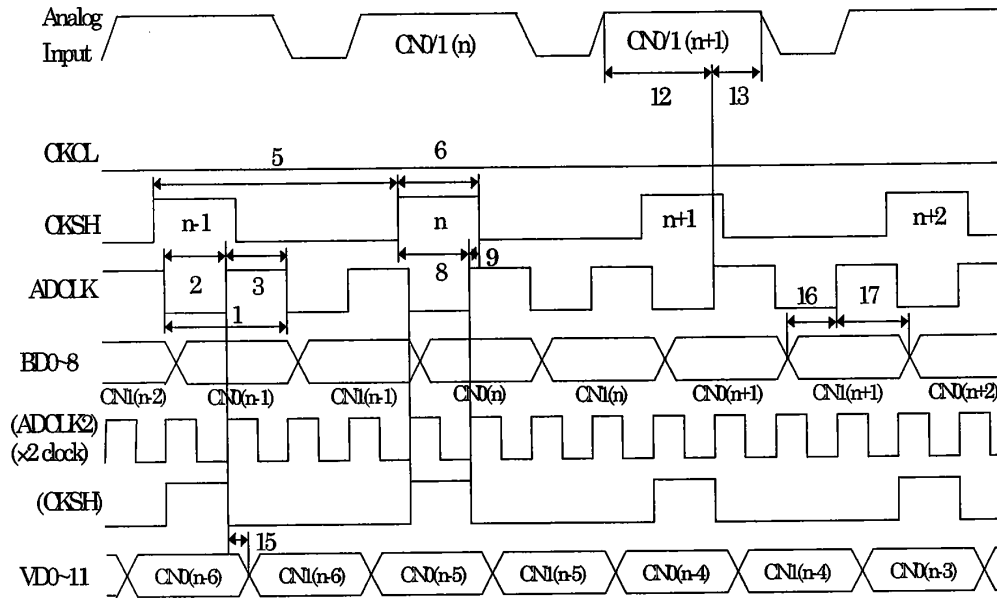

Fig.9 2Channel Mode (DC connect)

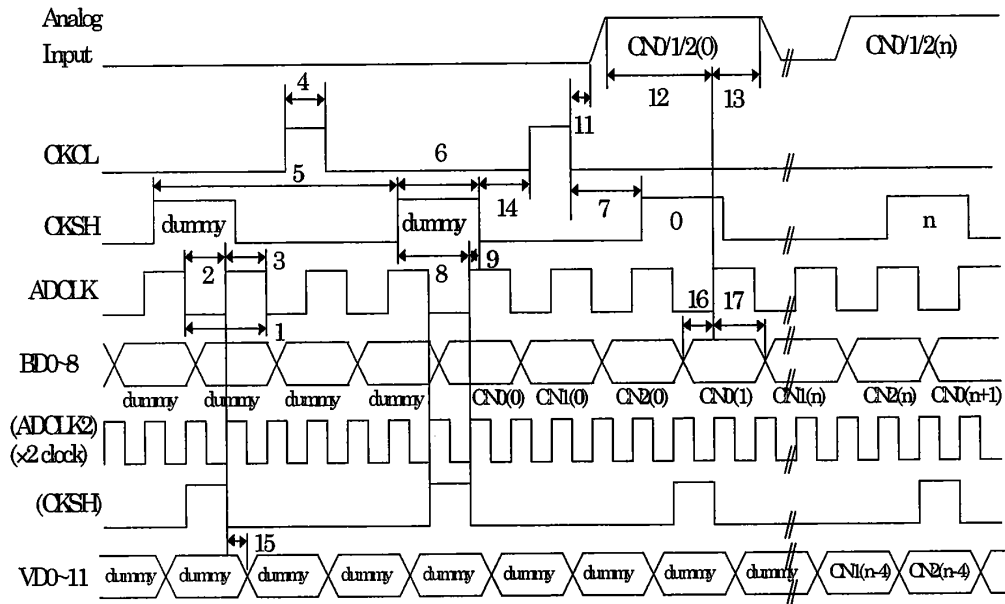

Fig.10 3Channel Mode (Line Clamp for CIS)

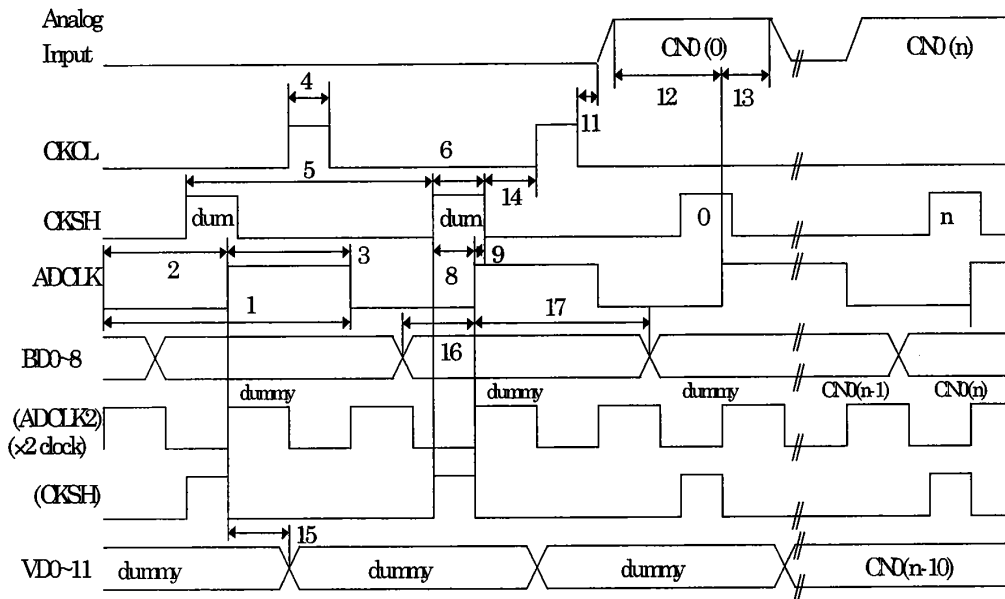

Fig.11 1Channel Mode (Line Clamp for CIS)

(3)Line Clamp mode for CIS timing

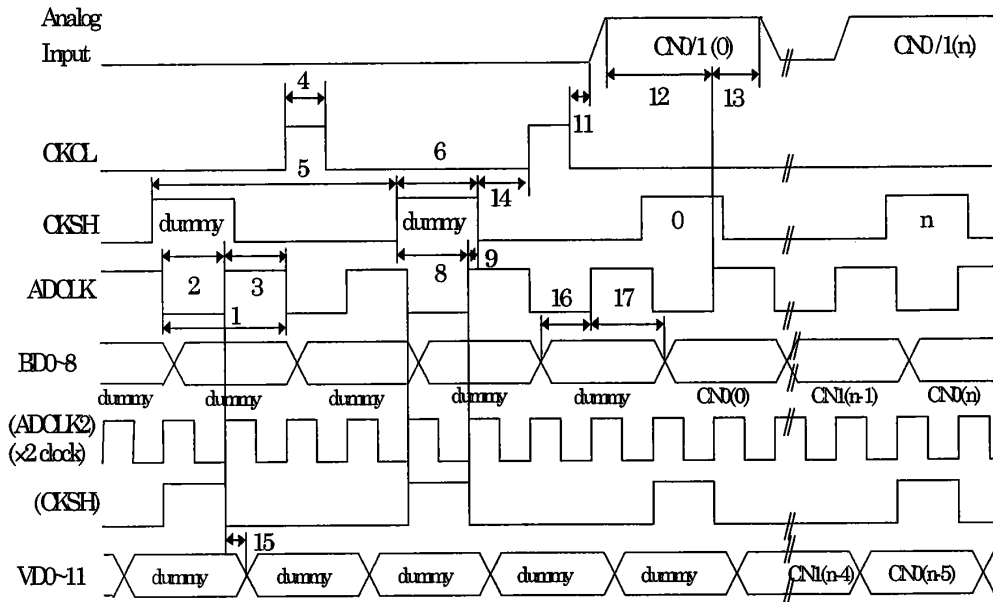

Fig.12 2Channel Mode (Line Clamp for CIS)

(4)Line Clamp mode for CCD timing

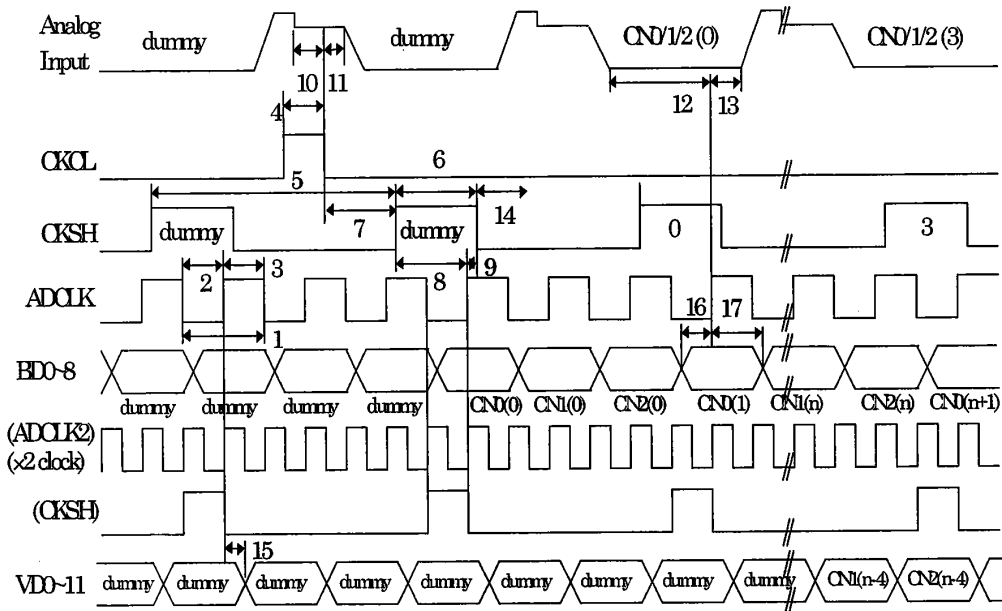

Fig.13 3Channel Mode (Line Clamp for CCD)

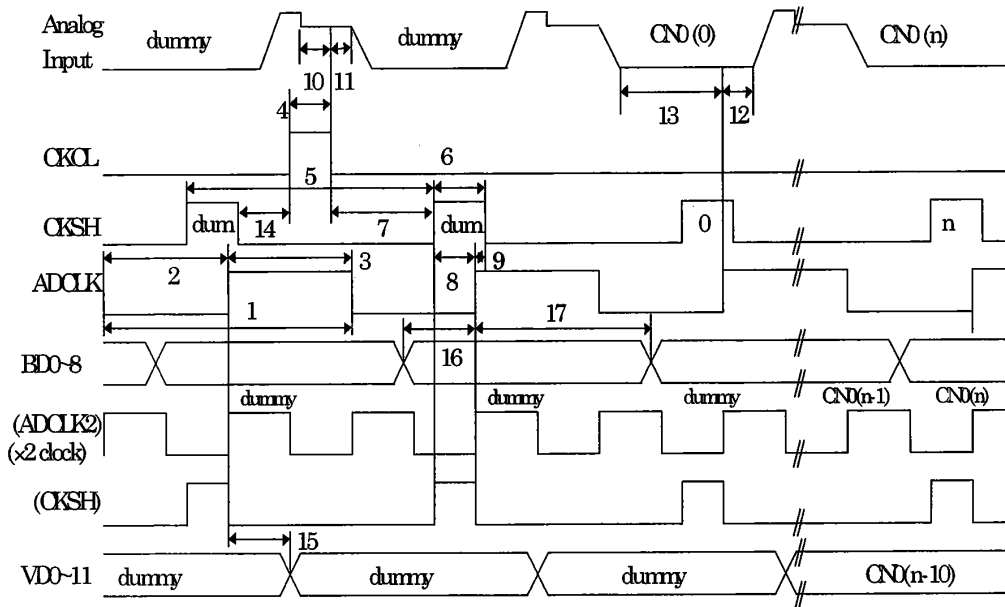

Fig.14 1Channel Mode (Line Clamp for CCD)

(4)Line Clamp mode for CCD timing

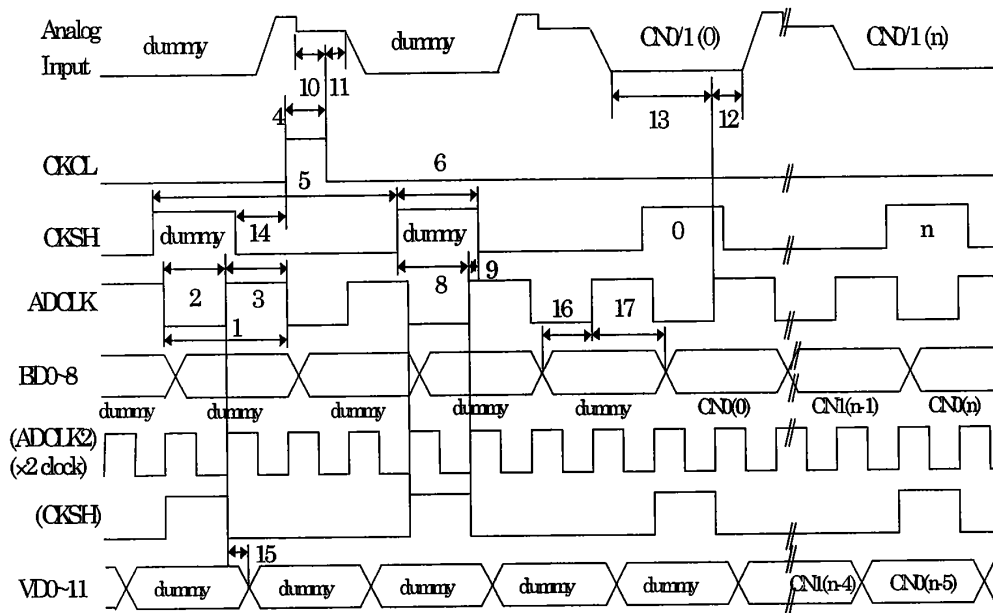

Fig.15 2Channel Mode (Line Clamp for CCD)

(Note 1) ( ) of signal name in Fig.1-.15 shows internal node signal.

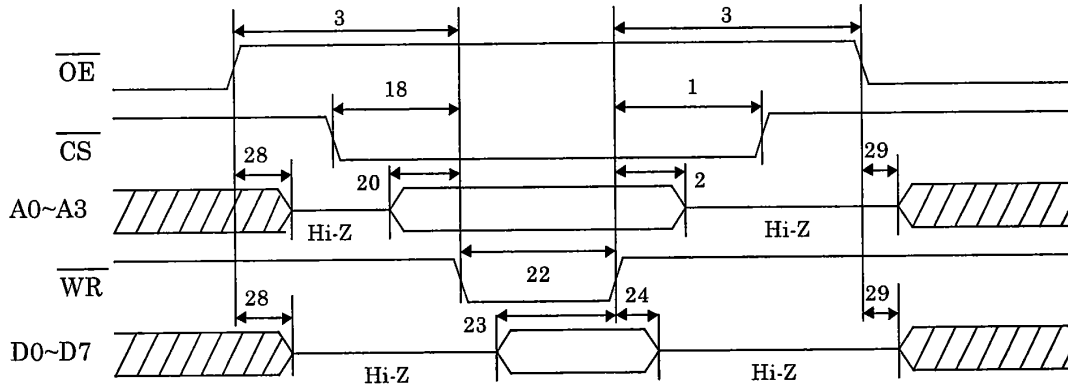

Fig.16 Register Write(Parallel I/F)

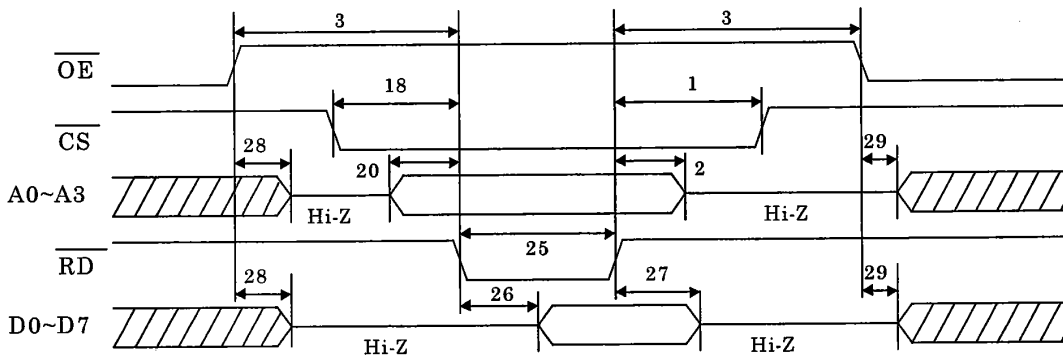

Fig.17 Register Read(Parallel I/F)

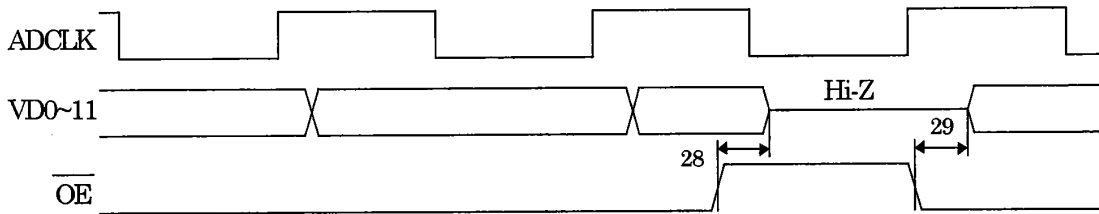

Fig.18 Video Data Disable

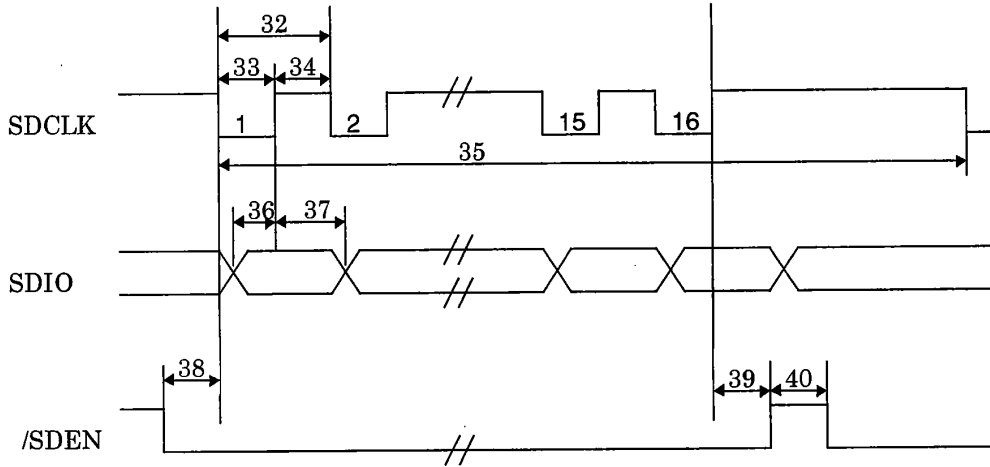

Fig.19 Register Write(3 Wire Serial I/F)

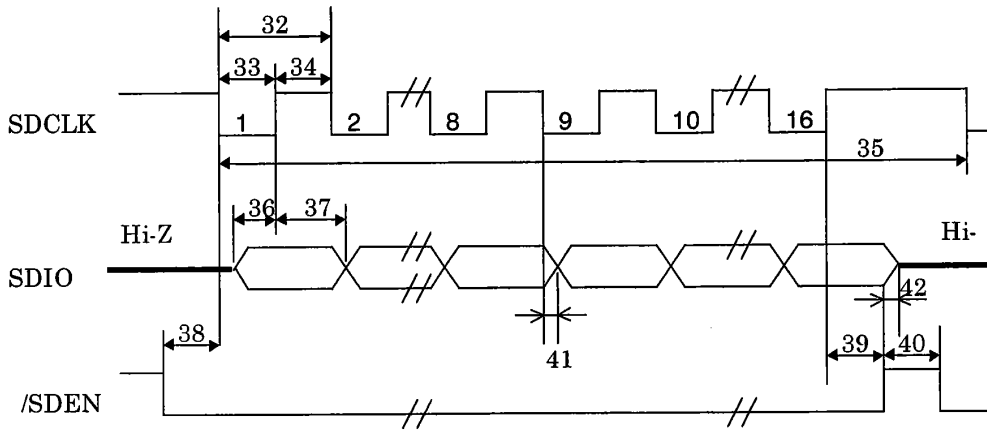

Fig.20 Register Read(3 Wire Serial I/F)

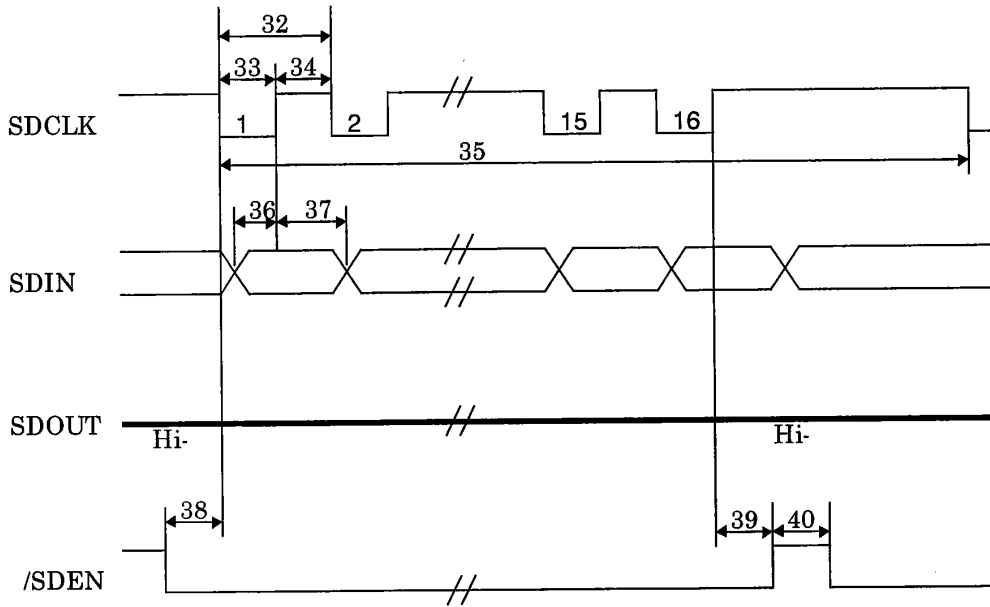

Fig.21 Register Write(4 Wire Serial I/F)

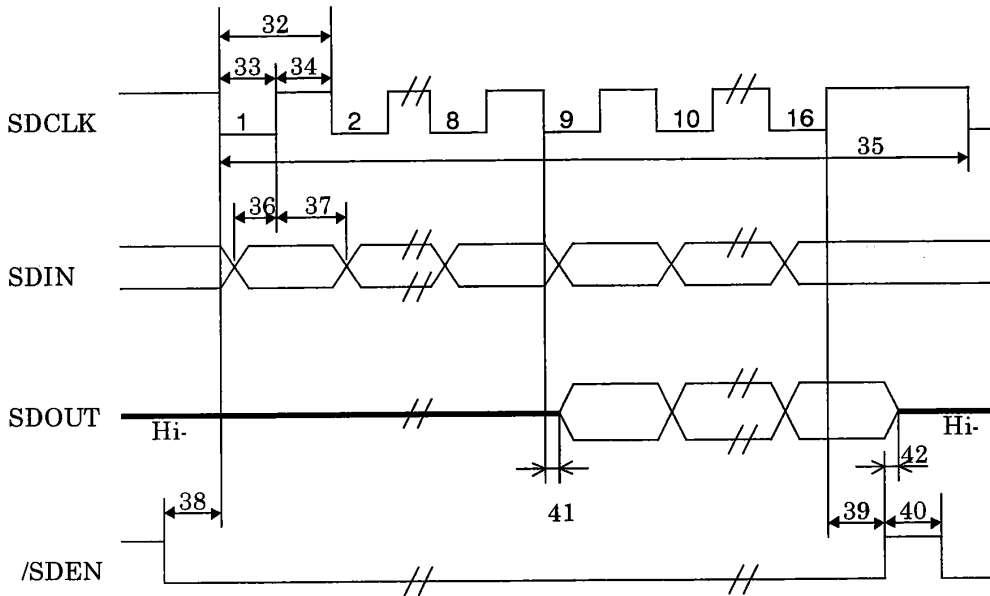
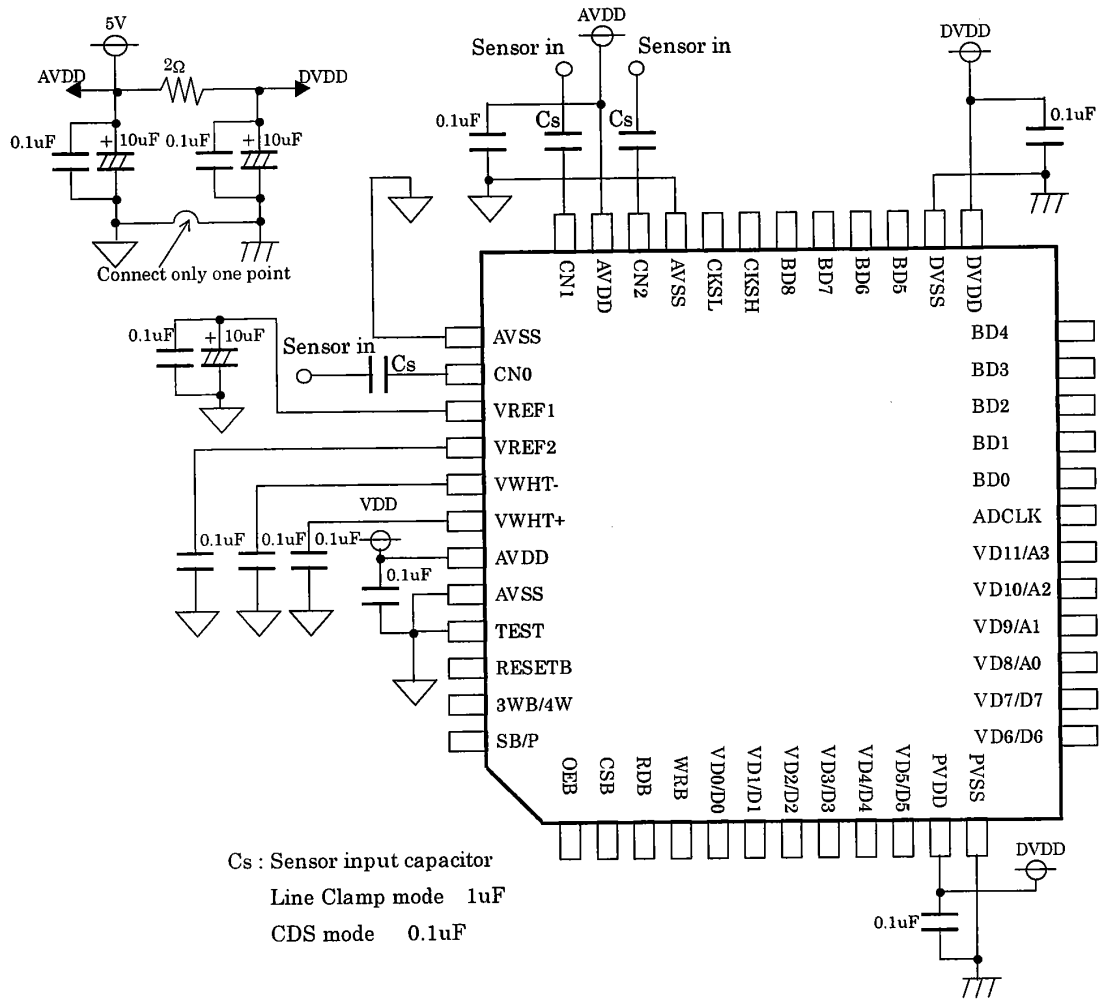

Fig.22 Register Read(4 Wire Serial I/F)

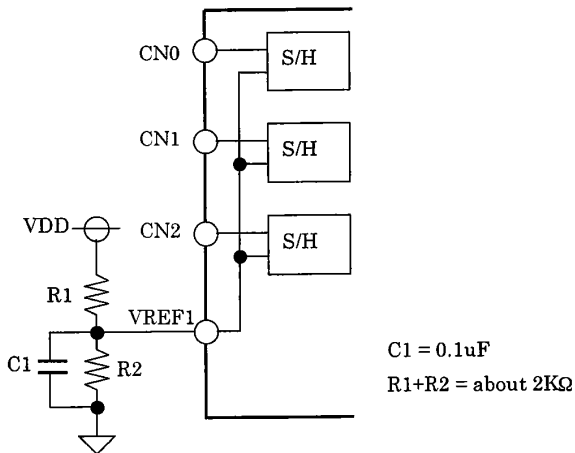

Fig. 23 Reset Pulse

Recommended Circuit



VREF1 input (DC connect mode)



Package

■ Marking

- (1) Pin 1 indicated (The chamfered corner indicates pin number 1.)
- (2) Date code: XXXXXXX (7 digits)  
Higher order four digits: week code  
Lower order three digits: In-house control code
- (3) Marking code: AK8412
- (4) Manufacturing Country Name Indication: JAPAN
- (5) Asahi Kasei Logo

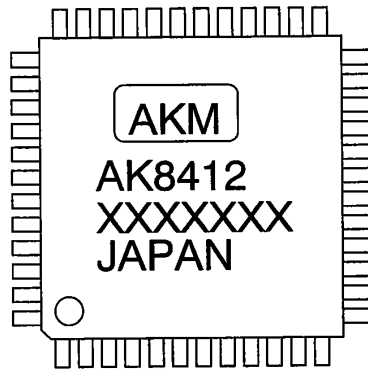

■ Package

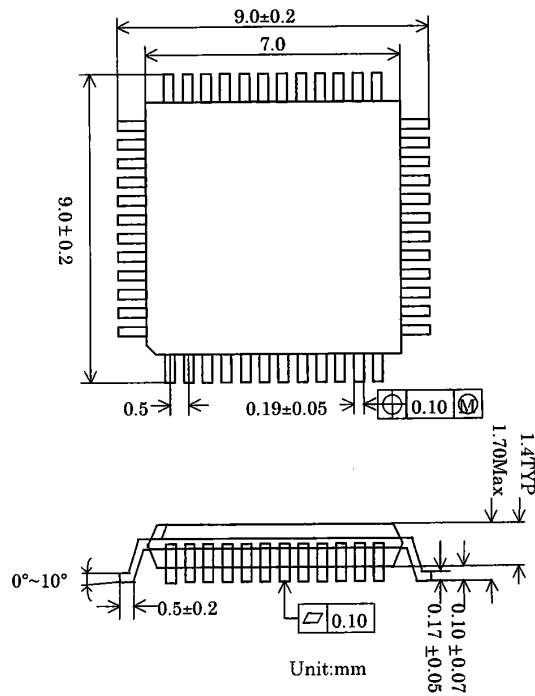

## IMPORTANT NOTICE

- These products and their specifications are subject to change without notice. Before considering any use or application, consult the Asahi Kasei Microsystems Co., Ltd. (AKM) sales office or authorized distributor concerning their current status.
- AKM assumes no liability for infringement of any patent, intellectual property, or other right in the application or use of any information contained herein.
- Any export of these products, or devices or systems containing them, may require an export license or other official approval under the law and regulations of the country of export pertaining to customs and tariffs, currency exchange, or strategic materials.
- AKM products are neither intended nor authorized for use as critical components in any safety, life support, or other hazard related device or system, and AKM assumes no responsibility relating to any such use, except with the express written consent of the Representative Director of AKM. As used here:
  - (a) A hazard related device or system is one designed or intended for life support or maintenance of safety or for applications in medicine, aerospace, nuclear energy, or other fields, in which its failure to function or perform may reasonably be expected to result in loss of life or in significant injury or damage to person or property.
  - (b) A critical component is one whose failure to function or perform may reasonably be expected to result, whether directly or indirectly, in the loss of the safety or effectiveness of the device or system containing it, and which must therefore meet very high standards of performance and reliability.
- It is the responsibility of the buyer or distributor of an AKM product who distributes, disposes of, or otherwise places the product with a third party to notify that party in advance of the above content and conditions, and the buyer or distributor agrees to assume any and all responsibility and liability for and hold AKM harmless from any and all claims arising from the use of said product in the absence of such notification.

## Looking for pricing, stock, or lifecycle information?

Click below to explore more details on WIN SOURCE:

- ⊖ [View AK8412 on WIN SOURCE](#)
- ⊖ [Asahi Kasei Microsystems](#) Information

## Optimize Your Supply Chain with WIN SOURCE Solutions

- ✓ Global Sourcing Solution
- ✓ Obsolete Management
- ✓ Cost Control Management
- ✓ Shortage Management
- ✓ Alternative Solution
- ✓ Excess Inventory Management