



# FAN7393

## Half-Bridge Gate Drive IC

### Features

- Floating Channel for Bootstrap Operation to +600V
- Typically 2.5A/2.5A Sourcing/Sinking Current Driving Capability
- Extended Allowable Negative  $V_S$  Swing to -9.8V for Signal Propagation at  $V_{BS}=15V$
- High-Side Output in Phase of IN Input Signal
- 3.3V and 5V Input Logic Compatible
- Matched Propagation Delay for Both Channels
- Built-in Shutdown Function
- Built-in UVLO Functions for Both Channels
- Built-in Common-Mode dv/dt Noise Cancelling Circuit
- Internal 370ns Minimum Dead Time at  $R_{DT}=0 \Omega$
- Programmable Turn-on Delay Control (Dead-Time)

### Applications

- High-Speed Power MOSFET and IGBT Gate Driver
- Induction Heating
- High-Power DC-DC Converter
- Synchronous Step-Down Converter
- Motor Drive Inverter

### Description

The FAN7393 is a half-bridge, gate-drive IC with shut-down and programmable dead-time control functions that can drive high-speed MOSFETs and IGBTs operating up to +600V. It has a buffered output stage with all NMOS transistors designed for high-pulse-current driving capability and minimum cross-conduction.

Fairchild's high-voltage process and common-mode noise canceling techniques provide stable operation of the high-side driver under high dv/dt noise circumstances. An advanced level-shift circuit offers high-side gate driver operation up to  $V_S=-9.8V$  (typical) for  $V_{BS}=15V$ .

The UVLO circuit prevents malfunction when  $V_{DD}$  and  $V_{BS}$  are lower than the specified threshold voltage.

The high-current and low-output voltage drop feature makes this device suitable for diverse half- and full-bridge inverters; motor drive inverters, switching mode power supplies, induction heating, and high-power DC-DC converter applications.

14-SOP

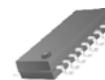

### Ordering Information

Part Number	Package	Operating Temperature Range	Eco Status	Packing Method
FAN7393M	14-Lead, Small Outline Integrated Circuit (SOIC), Non-JEDEC, .150 Inch Narrow Body, 225SOP	-40°C to +125°C	RoHS	Tube
FAN7393MX				Tape & Reel



For Fairchild's definition of Eco Status, please visit: [http://www.fairchildsemi.com/company/green/rohs\\_green.html](http://www.fairchildsemi.com/company/green/rohs_green.html).

### Typical Application Diagrams

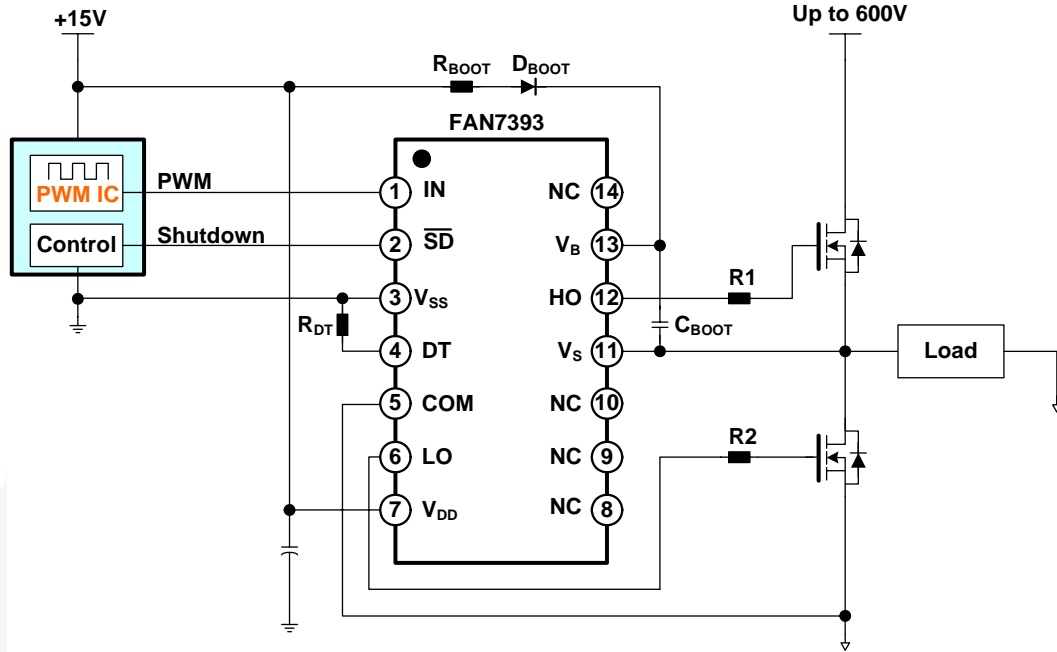

Figure 1. Typical Application Circuit

### Internal Block Diagram

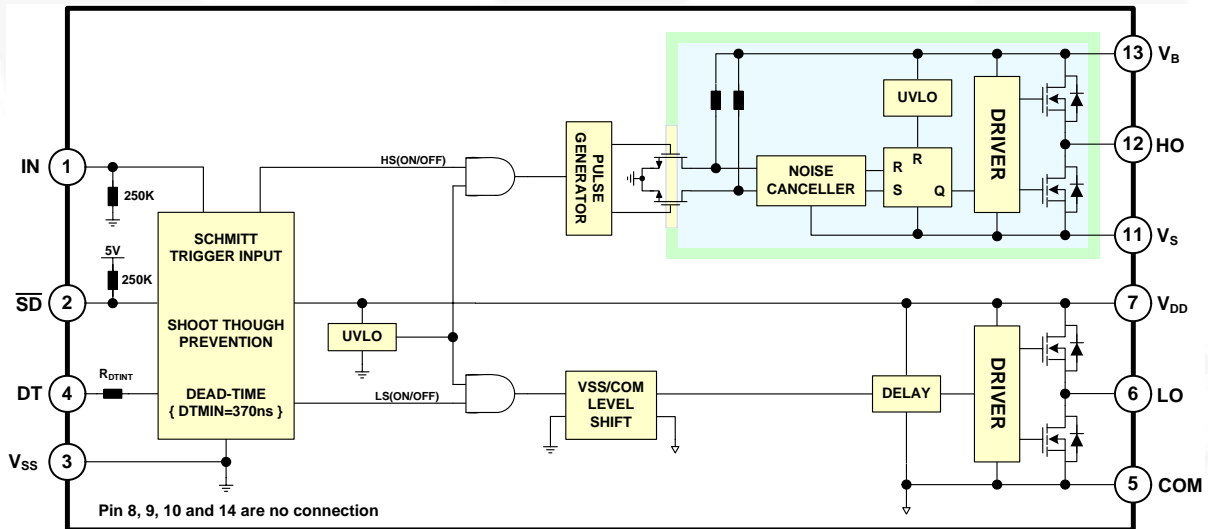

Figure 2. Functional Block Diagram

## Pin Configuration

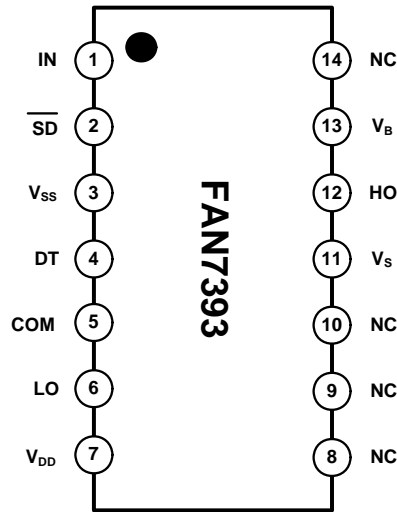

Figure 3. Pin Configurations (Top View)

## Pin Definitions

Pin #	Name	Description
1	IN	Logic Input for High-Side and Low-Side Gate Driver Output, In-Phase with HO
2	$\overline{\text{SD}}$	Logic Input for Shutdown
3	$V_{SS}$	Logic Ground
4	DT	Dead-Time Control with External Resistor (Referenced to $V_{SS}$ )
5	COM	Ground
6	LO	Low-Side Driver Return
7	$V_{DD}$	Supply Voltage
8	NC	No Connection
9	NC	No Connection
10	NC	No Connection
11	$V_S$	High-Voltage Floating Supply Return
12	HO	High-Side Driver Output
13	$V_B$	High-Side Floating Supply
14	NC	No Connection

## Absolute Maximum Ratings

Stresses exceeding the absolute maximum ratings may damage the device. The device may not function or be operable above the recommended operating conditions and stressing the parts to these levels is not recommended. In addition, extended exposure to stresses above the recommended operating conditions may affect device reliability. The absolute maximum ratings are stress ratings only.  $T_A=25^{\circ}\text{C}$  unless otherwise specified.

Symbol	Characteristics	Min.	Max.	Unit
$V_B$	High-Side Floating Supply Voltage	-0.3	625.0	V
$V_S$	High-Side Floating Offset Voltage	$V_B-25$	$V_B+0.3$	V
$V_{HO}$	High-Side Floating Output Voltage	$V_S-0.3$	$V_B+0.3$	V
$V_{LO}$	Low-Side Output Voltage	-0.3	$V_{DD}+0.3$	V
$V_{DD}$	Low-Side and Logic Fixed Supply Voltage	-0.3	25.0	V
$V_{IN}$	Logic Input Voltage (IN)	-0.3	$V_{DD}+0.3$	V
$V_{SD}$	Logic Input Voltage ( $\overline{SD}$ )	$V_{SS}$	5.5	V
DT	Programmable Dead-time Pin Voltage	-0.3	$V_{DD}+0.3$	V
$V_{SS}$	Logic Ground	$V_{DD}-25$	$V_{DD}+0.3$	V
$dV_S/dt$	Allowable Offset Voltage Slew Rate		$\pm 50$	V/ns
$P_D$	Power Dissipation <sup>(1, 2, 3)</sup>		1	W
$\theta_{JA}$	Thermal Resistance		110	$^{\circ}\text{C}/\text{W}$
$T_J$	Junction Temperature		+150	$^{\circ}\text{C}$
$T_{STG}$	Storage Temperature	-55	+150	$^{\circ}\text{C}$

### Notes:

- Mounted on 76.2 x 114.3 x 1.6mm PCB (FR-4 glass epoxy material).
- Refer to the following standards:  
JESD51-2: Integral circuits thermal test method environmental conditions - natural convection, and  
JESD51-3: Low effective thermal conductivity test board for leaded surface mount packages.
- Do not exceed maximum  $P_D$  under any circumstances.

## Recommended Operating Conditions

The Recommended Operating Conditions table defines the conditions for actual device operation. Recommended operating conditions are specified to ensure optimal performance to the datasheet specifications. Fairchild does not recommend exceeding them or designing to absolute maximum ratings.

Symbol	Parameter	Min.	Max.	Unit
$V_B$	High-Side Floating Supply Voltage	$V_S+10$	$V_S+20$	V
$V_S$	High-Side Floating Supply Offset Voltage	$6-V_{DD}$	600	V
$V_{HO}$	High-Side Output Voltage	$V_S$	$V_B$	V
$V_{DD}$	Low-Side and Logic Fixed Supply Voltage	10	20	V
$V_{LO}$	Low-Side Output Voltage	COM	$V_{DD}$	V
$V_{IN}$	Logic Input Voltage (IN)	$V_{SS}$	$V_{DD}$	V
$V_{SD}$	Logic Input Voltage ( $\overline{SD}$ ) <sup>(4)</sup>	$V_{SS}$	5	V
DT	Programmable Dead-Time Pin Voltage	$V_{SS}$	$V_{DD}$	V
$V_{SS}$	Logic Ground	-5	+5	V
$T_A$	Operating Ambient Temperature	-40	+125	$^{\circ}\text{C}$

### Note:

- Shutdown ( $\overline{SD}$ ) input is internally clamped with 5.2V.

## Electrical Characteristics

$V_{BIAS}(V_{DD}, V_{BS})=15.0V$ ,  $V_{SS}=COM=0V$ ,  $DT=V_{SS}$  and  $T_A = 25^\circ C$ , unless otherwise specified. The  $V_{IN}$  and  $I_{IN}$  parameters are referenced to  $V_{SS}/COM$  and are applicable to the respective input leads: IN and SD. The  $V_O$  and  $I_O$  parameters are referenced to COM and are applicable to the respective output leads: HO and LO.

Symbol	Characteristics	Test Condition	Min.	Typ.	Max.	Unit
<b>POWER SUPPLY SECTION</b>						
$I_{QDD}$	Quiescent $V_{DD}$ Supply Current	$V_{IN}=0V$ or $5V$		0.9	1.5	mA
$I_{QBS}$	Quiescent $V_{BS}$ Supply Current	$V_{IN}=0V$ or $5V$		50	100	$\mu A$
$I_{PDD}$	Operating $V_{DD}$ Supply Current	$f_{IN}=20KHz$ , No Load		1.3	1.9	mA
$I_{PBS}$	Operating $V_{BS}$ Supply Current	$C_L=1nF$ , $f_{IN}=20KHz$ , rms		450	800	$\mu A$
$I_{SD}$	Shutdown Mode Supply Current	$\overline{SD}=V_{SS}$		0.95	1.5	mA
$I_{LK}$	Offset Supply Leakage Current	$V_B=V_S=600V$			10	$\mu A$
<b>BOOTSTRAPPED SUPPLY SECTION</b>						
$V_{DDUV+}$ $V_{BSUV+}$	$V_{DD}$ and $V_{BS}$ Supply Under-Voltage Positive-Going Threshold Voltage	$V_{IN}=0V$ , $V_{DD}=V_{BS}=\text{Sweep}$	8.0	9.0	10	V
$V_{DDUV-}$ $V_{BSUV-}$	$V_{DD}$ and $V_{BS}$ Supply Under-Voltage Negative-Going Threshold Voltage	$V_{IN}=0V$ , $V_{DD}=V_{BS}=\text{Sweep}$	7.4	8.4	9.4	V
$V_{DDUVH-}$ $V_{BSUVH}$	$V_{DD}$ and $V_{BS}$ Supply Under-Voltage Lockout Hysteresis Voltage	$V_{IN}=0V$ , $V_{DD}=V_{BS}=\text{Sweep}$		0.6		V
<b>INPUT LOGIC SECTION</b>						
$V_{IH}$	Logic "1" Input Voltage for HO & Logic "0" for LO		2.5			V
$V_{IL}$	Logic "0" Input Voltage for HO & Logic "1" for LO				0.8	V
$I_{IN+}$	Logic Input High Bias Current	$V_{IN}=5V$ , $\overline{SD}=0V$		20	50	$\mu A$
$I_{IN-}$	Logic Input Low Bias Current	$V_{IN}=0V$ , $\overline{SD}=5V$			3	$\mu A$
$R_{IN}$	Logic Input Pull-Down Resistance		100	250		$K\Omega$
$V_{SDCLAMP}$	Shutdown ( $\overline{SD}$ ) Input Clamping Voltage			5.0	5.5	V
$\overline{SD+}$	Shutdown ( $\overline{SD}$ ) Input Positive-Going Threshold		2.5			V
$\overline{SD-}$	Shutdown ( $\overline{SD}$ ) input Negative-Going Threshold				0.8	V
$R_{PSD}$	Shutdown ( $\overline{SD}$ ) Input Pull-Up Resistance		100	250		$K\Omega$
<b>GATE DRIVER OUTPUT SECTION</b>						
$V_{OH}$	High-Level Output Voltage ( $V_{BIAS} - V_O$ )	No Load			1.5	V
$V_{OL}$	Low-Level Output Voltage	No Load			100	mV
$I_{O+}$	Output High, Short-Circuit Pulsed Current <sup>(5)</sup>	$V_{HO}=0V$ , $V_{IN}=5V$ , $PW \leq 10\mu s$	2.0	2.5		A
$I_{O-}$	Output Low, Short-Circuit Pulsed Current <sup>(5)</sup>	$V_{HO}=15V$ , $V_{IN}=0V$ , $PW \leq 10\mu s$	2.0	2.5		A
$V_S$	Allowable Negative $V_S$ Pin Voltage for IN Signal Propagation to HO			-9.8	-7.0	V

### Note:

5 These parameters guaranteed by design.

## Dynamic Electrical Characteristics

$V_{BIAS}(V_{DD}, V_{BS})=15.0V$ ,  $V_{SS}=COM=0V$ ,  $C_L=1000pF$ ,  $DT=V_{SS}$  and  $T_A=25^\circ C$ , unless otherwise specified.

Symbol	Parameter	Conditions	Min.	Typ.	Max.	Unit
$t_{ON}$	Turn-On Propagation Delay Time <sup>(6)</sup>	$V_S=0V$ , $R_{DT}=0\Omega$		550	850	ns
$t_{OFF}$	Turn-Off Propagation Delay Time	$V_S=0V$		200	400	ns
$t_{SD}$	Shutdown Propagation Delay Time			180	270	ns
$Mt_{ON}$	Delay Matching, HO & LO Turn-On			0	100	ns
$Mt_{OFF}$	Delay Matching, HO & LO Turn-Off			0	50	ns
$t_R$	Turn-On Rise Time	$V_S=0V$		40	60	ns
$t_F$	Turn-Off Fall Time	$V_S=0V$		20	35	ns
DT	Dead Time: LO Turn-Off to HO Turn-On & HO Turn-Off to LO Turn-On	$R_{DT}=0\Omega$	270	370	470	ns
		$R_{DT}=750K\Omega$	1.6	2.0	2.4	$\mu s$
MDT	Dead Time matching= $ DT_{LO-HO} - DT_{HO-LO} $	$R_{DT}=0\Omega$		0	50	ns
		$R_{DT}=750K\Omega$		0	250	ns

### Note:

6 The turn-on propagation delay time includes dead time.

## Typical Characteristics

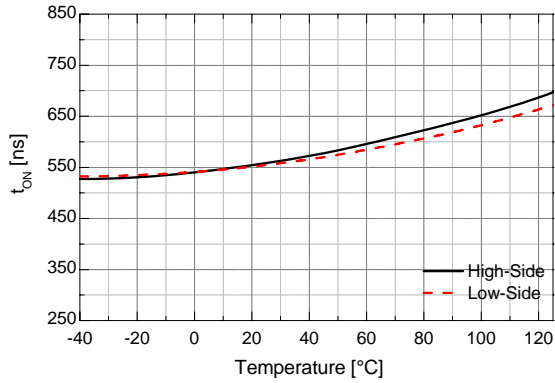

Figure 4. Turn-On Propagation Delay vs. Temperature

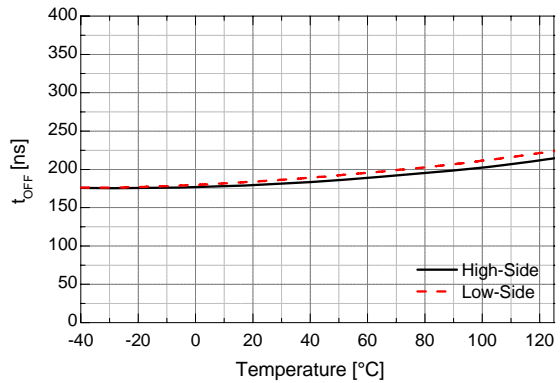

Figure 5. Turn-Off Propagation Delay vs. Temperature

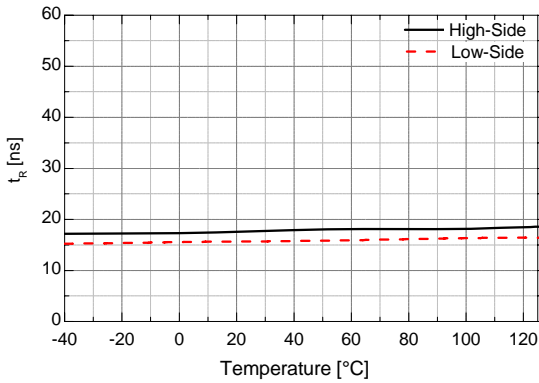

Figure 6. Turn-On Rise Time vs. Temperature

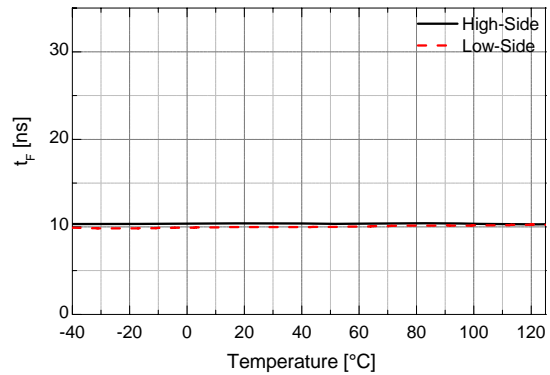

Figure 7. Turn-Off Fall Time vs. Temperature

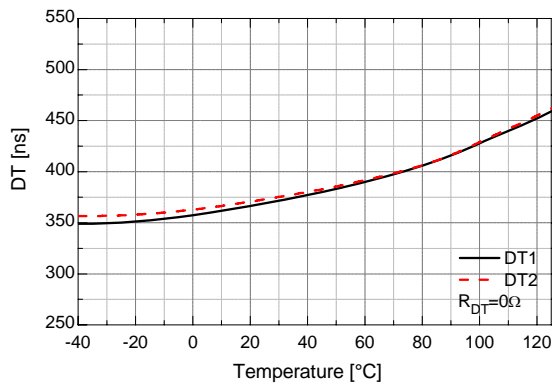

Figure 8. Dead Time ( $R_{DT}=0\Omega$ ) vs. Temperature

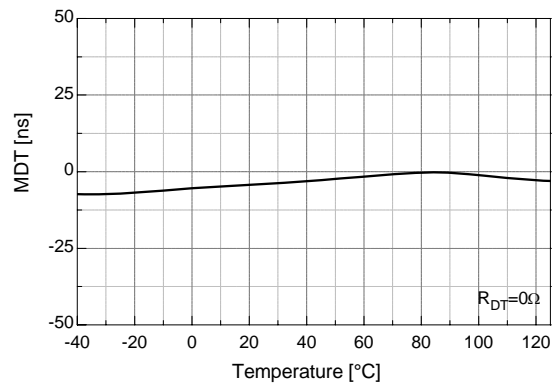

Figure 9. Dead Time Matching ( $R_{DT}=0\Omega$ ) vs. Temperature

Typical Characteristics (Continued)

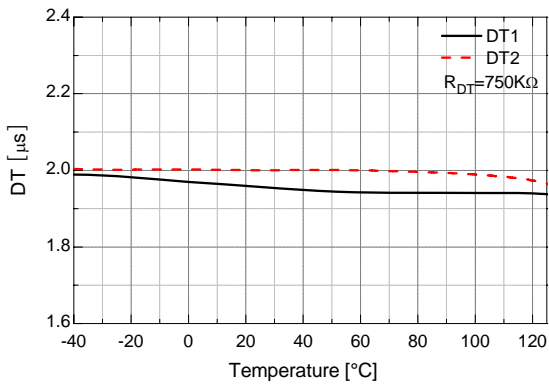

Figure 10. Dead Time ( $R_{DT}=750K\Omega$ ) vs. Temperature

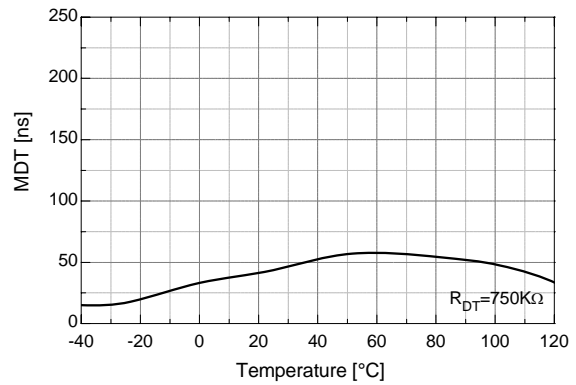

Figure 11. Dead Time Matching ( $R_{DT}=750K\Omega$ ) vs. Temperature

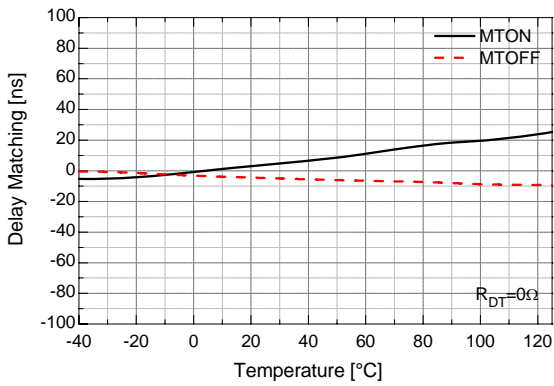

Figure 12. Delay Matching vs. Temperature

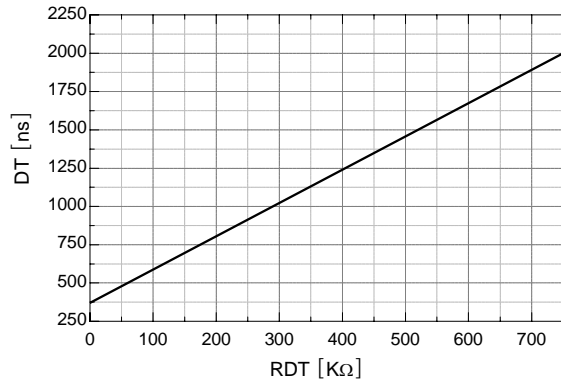

Figure 13. Dead Time vs.  $R_{DT}$

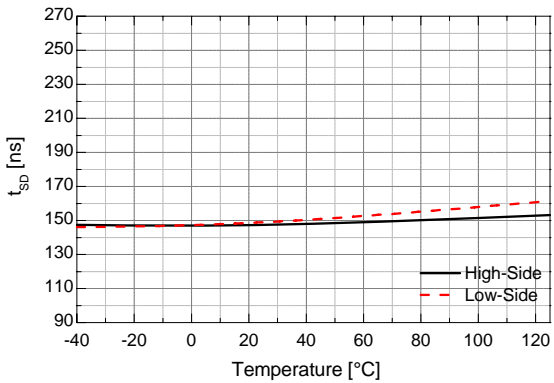

Figure 14. Shutdown Propagation Delay vs. Temperature

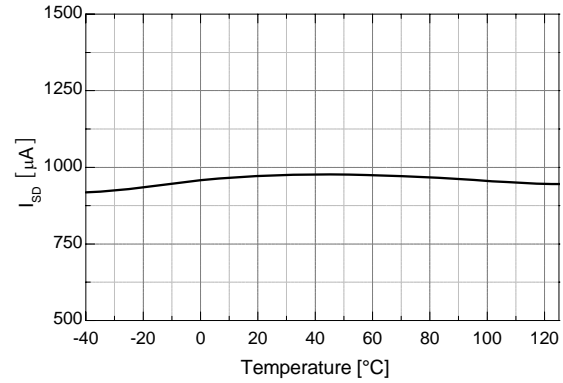

Figure 15. Shutdown Mode Supply Current vs. Temperature

Typical Characteristics (Continued)

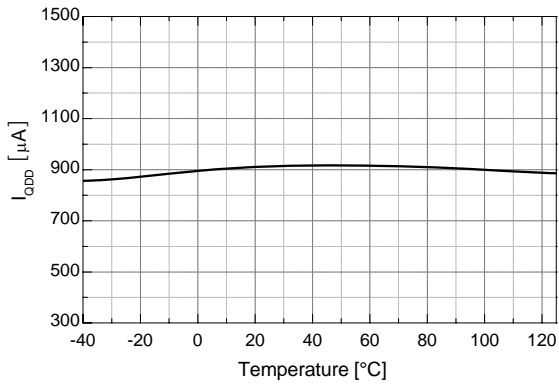

Figure 16. Quiescent  $V_{DD}$  Supply Current vs. Temperature

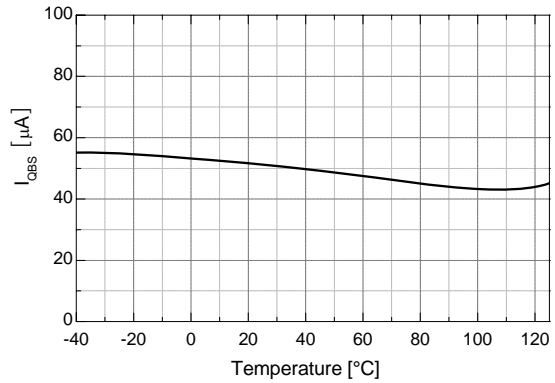

Figure 17. Quiescent  $V_{BS}$  Supply Current vs. Temperature

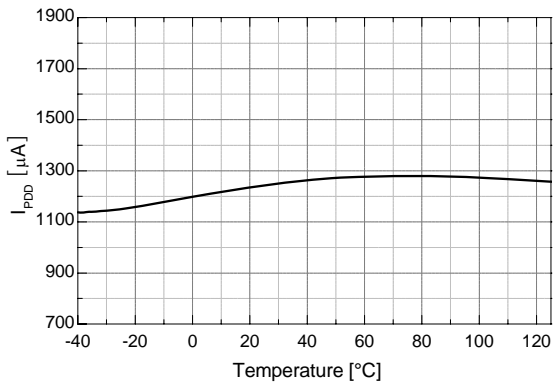

Figure 18. Operating  $V_{DD}$  Supply Current vs. Temperature

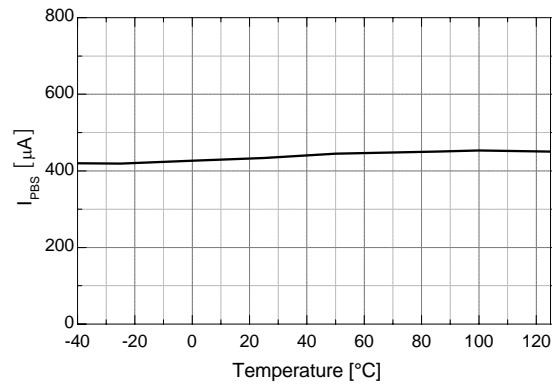

Figure 19. Operating  $V_{BS}$  Supply Current vs. Temperature

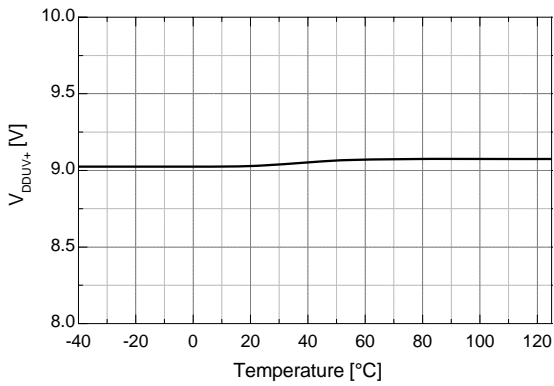

Figure 20.  $V_{DD}$  UVLO+ vs. Temperature

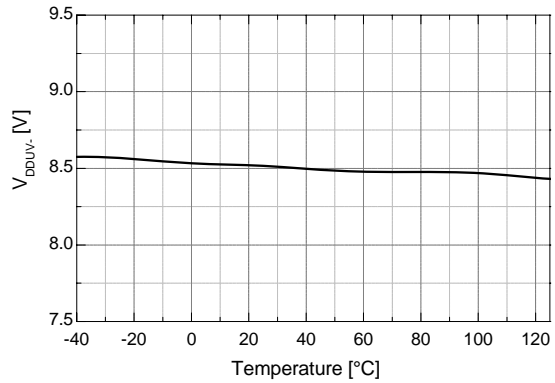

Figure 21.  $V_{DD}$  UVLO- vs. Temperature

Typical Characteristics (Continued)

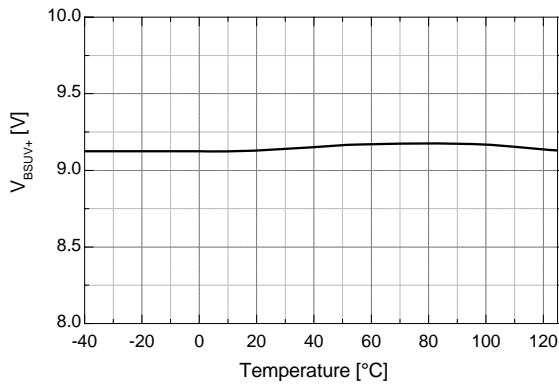

Figure 22. V<sub>BS</sub> UVLO+ vs. Temperature

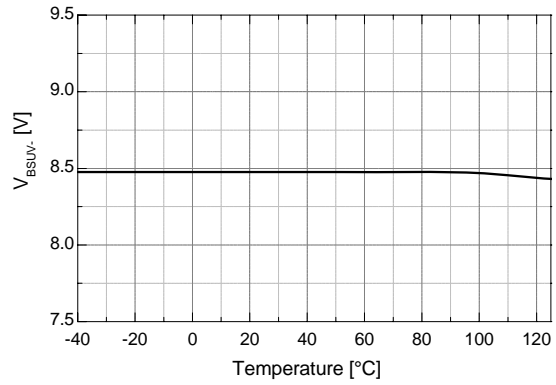

Figure 23. V<sub>BS</sub> UVLO- vs. Temperature

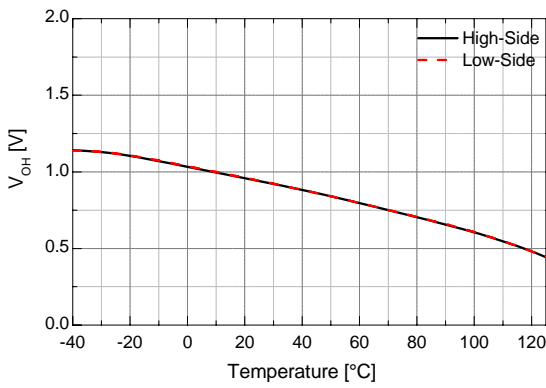

Figure 24. High-Level Output Voltage vs. Temperature

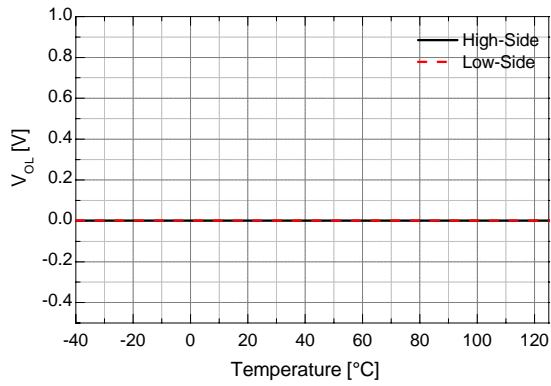

Figure 25. Low-Level Output Voltage vs. Temperature

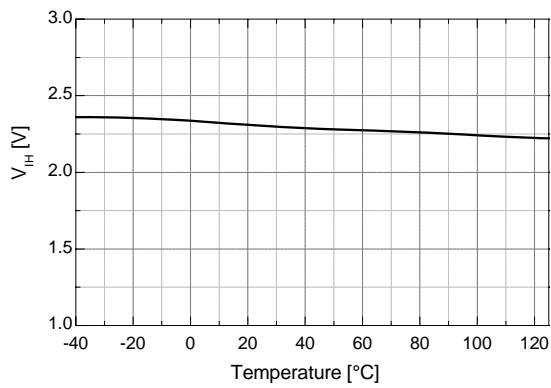

Figure 26. Logic High Input Voltage vs. Temperature

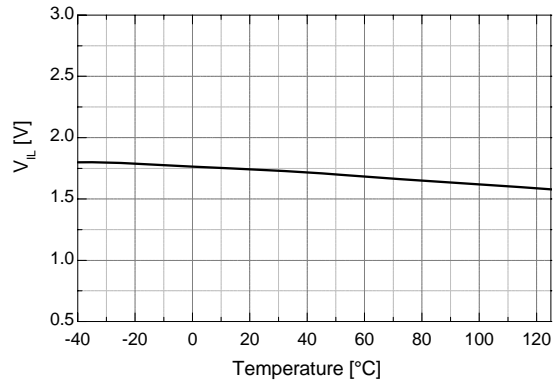

Figure 27. Logic Low Input Voltage vs. Temperature

Typical Characteristics (Continued)

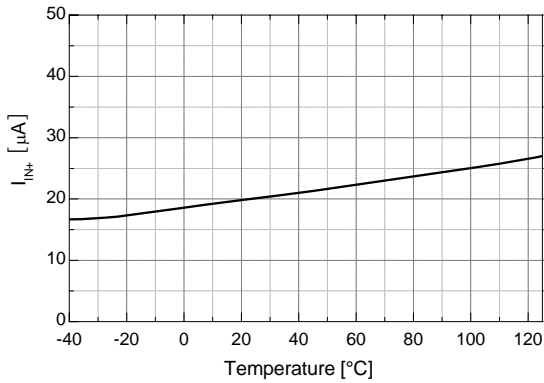

Figure 28. Logic Input High Bias Current vs. Temperature

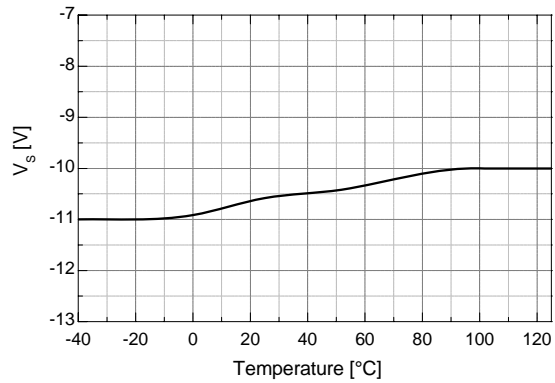

Figure 29. Allowable Negative V<sub>S</sub> Voltage vs. Temperature

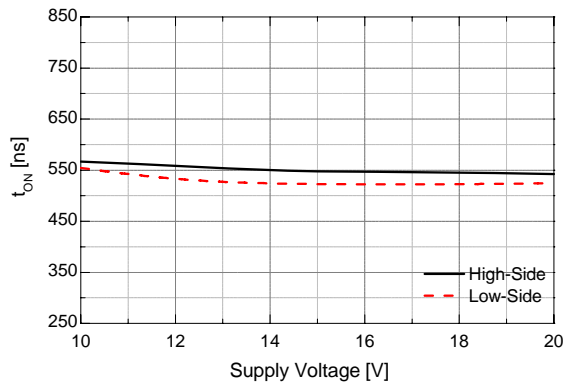

Figure 30. Turn-On Propagation Delay vs. Supply Voltage

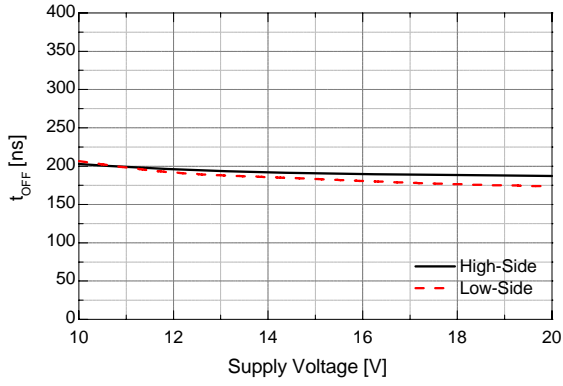

Figure 31. Turn-Off Propagation Delay vs. Supply Voltage

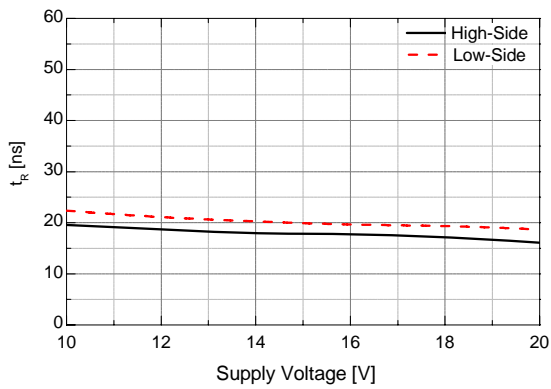

Figure 32. Turn-On Rise Time vs. Supply Voltage

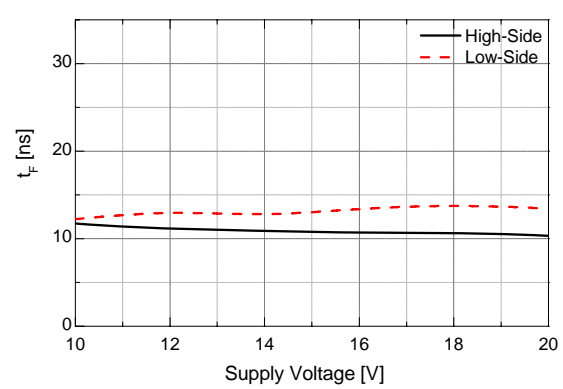

Figure 33. Turn-Off Fall Time vs. Supply Voltage

Typical Characteristics (Continued)

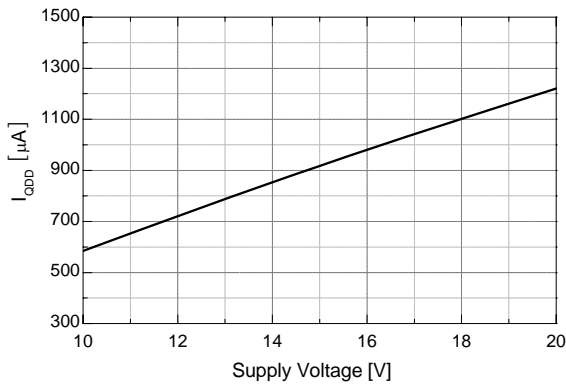

Figure 34. Quiescent  $V_{DD}$  Supply Current vs. Supply Voltage

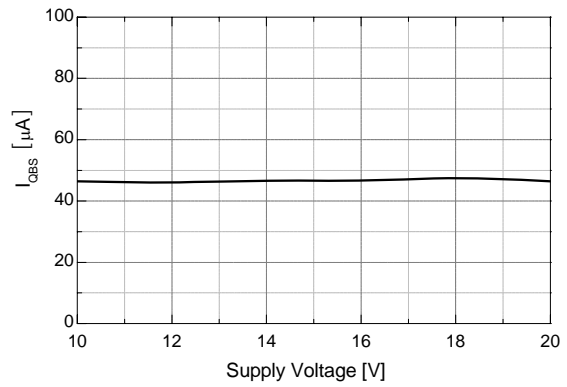

Figure 35. Quiescent  $V_{BS}$  Supply Current vs. Supply Voltage

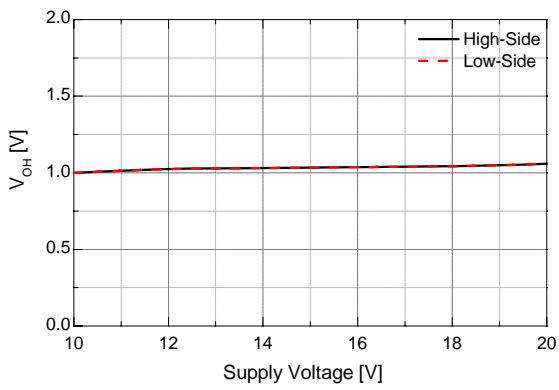

Figure 36. High-Level Output Voltage vs. Supply Voltage

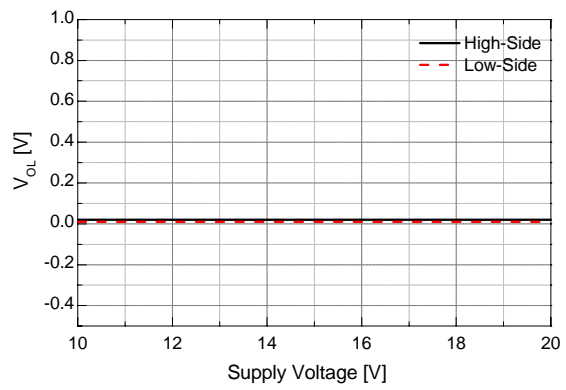

Figure 37. Low-Level Output Voltage vs. Supply Voltage

### Switching Time Definitions

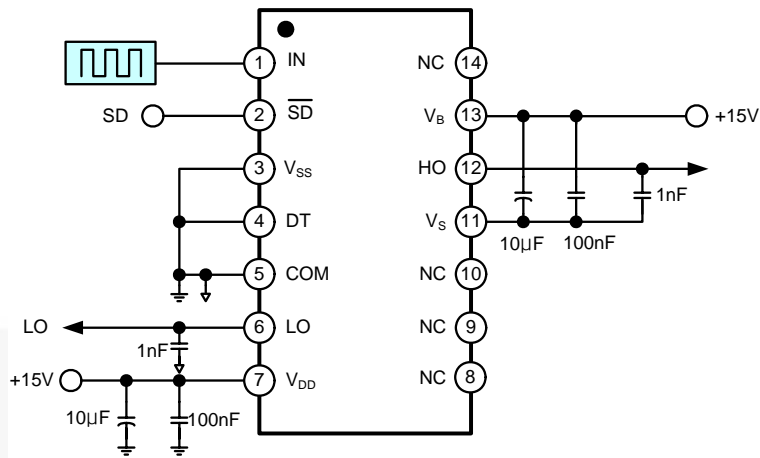

Figure 38. Switching Time Test Circuit

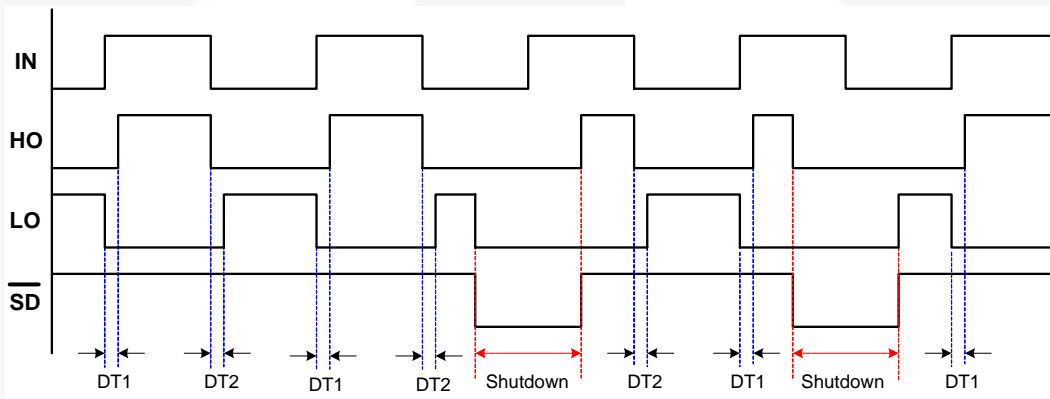

Figure 39. Input/Output Timing Diagram

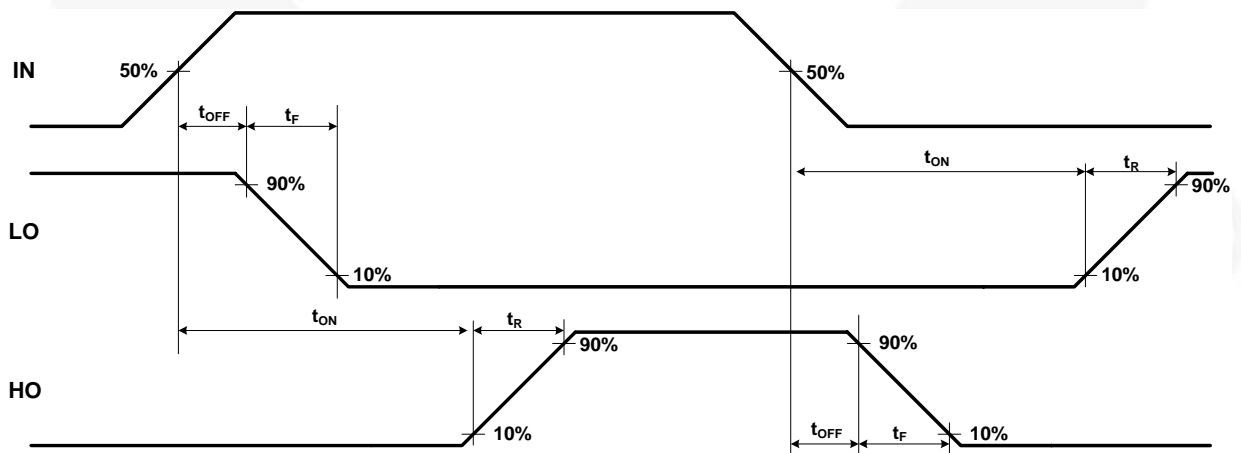

Figure 40. Switching Time Waveform Definition

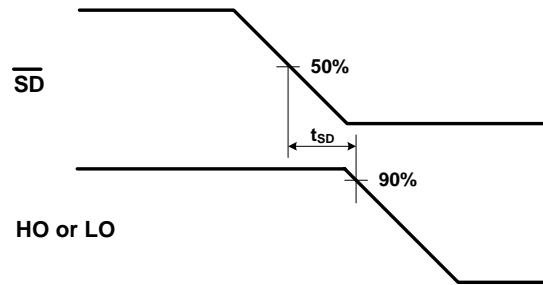

Figure 41. Shutdown Waveform Definition

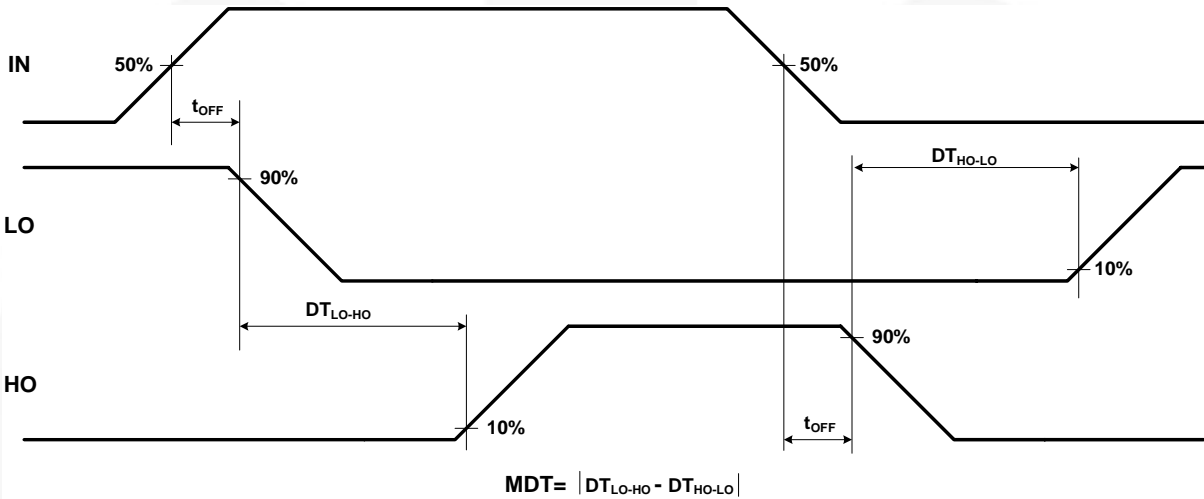

Figure 42. Dead Time Waveform Definition

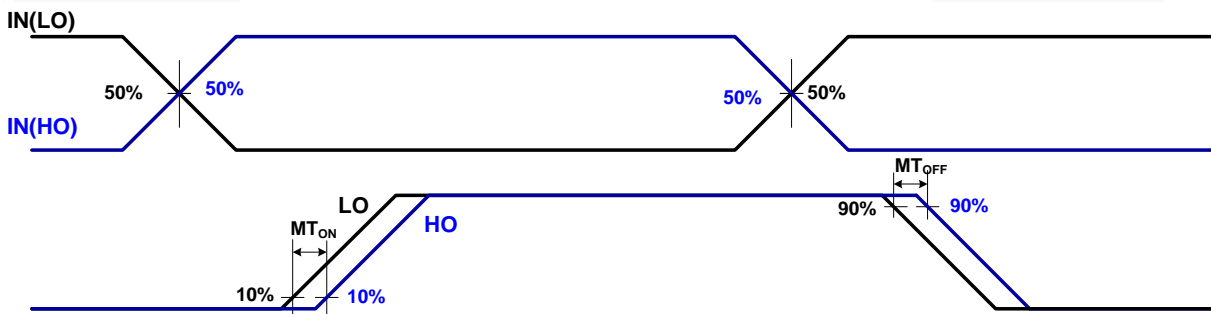

Figure 43. Delay Matching Waveform Definition

## Application Information

### Negative $V_S$ Transient

The bootstrap circuit has the advantage of being simple and low cost, but has some limitations. The biggest difficulty with this circuit is the negative voltage present at the emitter of the high-side switching device when the high-side switch is turned off in half-bridge applications.

If the high-side switch, Q1, turns-off while the load current is flowing to an inductive load; a current commutation occurs from high-side switch, Q1, to the diode, D2, in parallel with the low-side switch of the same inverter leg. Then the negative voltage present at the emitter of the high-side switching device, just before the freewheeling diode, D2, starts clamping, causes load current to suddenly flow to the low-side freewheeling diode, D2, as shown in Figure 44.

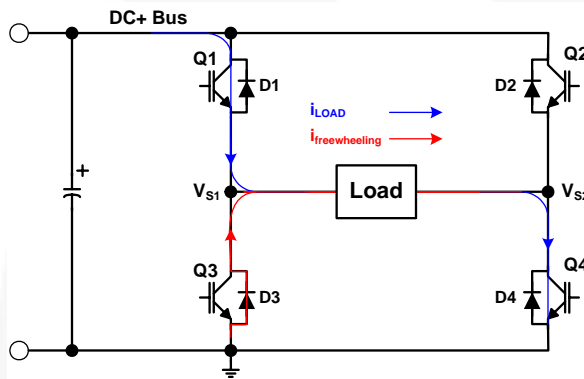

Figure 44. Half-Bridge Application Circuits

This negative voltage can be trouble for the gate driver's output stage. There is the possibility to develop an over-voltage condition of the bootstrap capacitor, input signal missing, and latch-up problems because it directly affects the source  $V_S$  pin of the gate driver, as shown in Figure 45. This undershoot voltage is called "negative  $V_S$  transient".

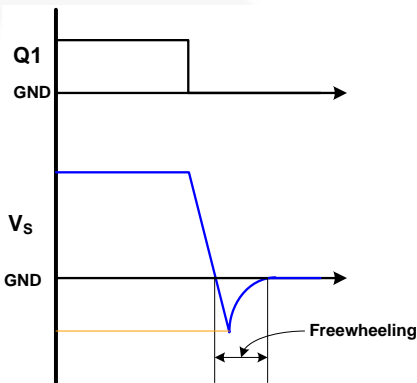

Figure 45.  $V_S$  Waveforms During Q1 Turn-Off

Figure 46 and Figure 47 show the commutation of the load current between the high-side switch, Q1, and low-side freewheeling diode, D3, in same inverter leg. The parasitic inductances in the inverter circuit from the wire bonding to the PCB tracks are jumped together in  $L_C$  and  $L_E$  for each IGBT. When the high-side switch, Q1, and low-side switch, Q4, are turned on, the  $V_{S1}$  node is below DC+ voltage by the voltage drops associated with the power switch and the parasitic inductances of the circuit due to load current is flows from Q1 and Q4, as shown in Figure 46. When the high-side switch, Q1, is turned off and Q4, remained turned on, the load current to flows the low-side freewheeling diode, D3, due to the inductive load connected to  $V_{S1}$ , as shown in Figure 47. The current flows from ground (which is connected to the COM pin of the gate driver) to the load and the negative voltage present at the emitter of the high-side switching device.

In this case, the COM pin of the gate driver is at a higher potential than the  $V_S$  pin due to the voltage drops associated with freewheeling diode, D3, and parasitic elements,  $L_{C3}$  and  $L_{E3}$ .

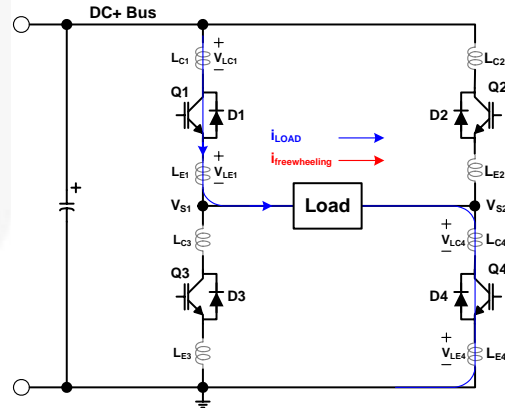

Figure 46. Q1 and Q4 Turn-On

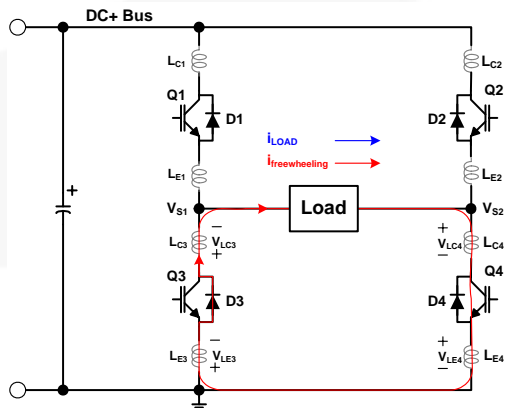

Figure 47. Q1 Turn-Off and D3 Conducting

The FAN7393 has a negative  $V_S$  transient performance curve, as shown in Figure 48.

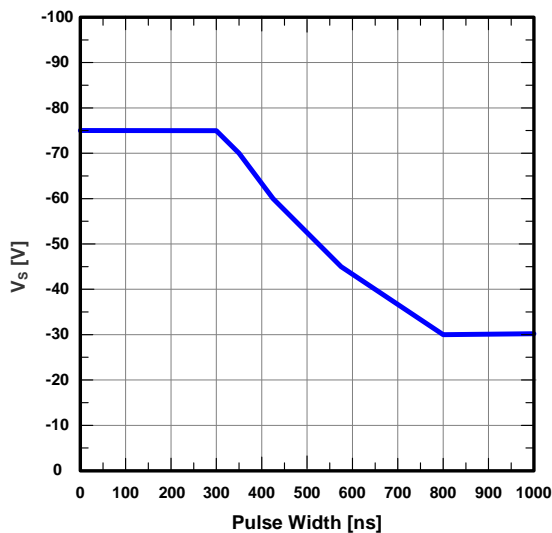

Figure 48. Negative  $V_S$  Transient Characteristic

Even though the FAN7393 has been shown able to handle these negative  $V_S$  transient conditions, it is strongly recommended that the circuit designer limit the negative  $V_S$  transient as much as possible by careful PCB layout to minimize the value of parasitic elements and component use. The amplitude of negative  $V_S$  voltage is proportional to the parasitic inductances and the turn-off speed,  $di/dt$ , of the switching device.

## General Guidelines

### Printed Circuit Board Layout

The layout recommended for minimized parasitic elements is as follows:

- Direct tracks between switches with no loops or deviation.
- Avoid interconnect links. These can add significant inductance.
- Reduce the effect of lead-inductance by lowering package height above the PCB.
- Consider co-locating both power switches to reduce track length.
- To minimize noise coupling, the ground plane should not be placed under or near the high-voltage floating side.
- To reduce the EM coupling and improve the power switch turn-on/off performance, the gate drive loops must be reduced as much as possible.

## Placement of Components

The recommended selection of component is as follows:

- Place a bypass capacitor between the  $V_{DD}$  and  $V_{SS}$  pins. A ceramic  $1\mu\text{F}$  capacitor is suitable for most applications. This component should be placed as close as possible to the pins to reduce parasitic elements.
- The bypass capacitor from  $V_{DD}$  to COM supports both the low-side driver and bootstrap capacitor recharge. A value at least ten times higher than the bootstrap capacitor is recommended.
- The bootstrap resistor,  $R_{BOOT}$ , must be considered in sizing the bootstrap resistance and the current developed during initial bootstrap charge. If the resistor is needed in series with the bootstrap diode, verify that  $V_B$  does not fall below COM (ground). Recommended use is typically  $5 \sim 10\Omega$ , which increases the  $V_{BS}$  time constant. If the voltage drop of the bootstrap resistor and diode is too high or the circuit topology does not allow a sufficient charging time, a fast recovery or ultra-fast recovery diode can be used.
- The bootstrap capacitor,  $C_{BOOT}$ , uses a low-ESR capacitor, such as a ceramic capacitor.

It is strongly recommended that the placement of components is as follows:

- Place components tied to the floating voltage pins ( $V_B$  and  $V_S$ ) near the respective high-voltage portions of the device and the FAN7393. NC (not connected) pins in this package maximize the distance between the high-voltage and low-voltage pins (see Figure 3).
- Place and route for bypass capacitors and gate resistors as close as possible to gate drive IC.
- Locate the bootstrap diode,  $D_{BOOT}$ , as close as possible to bootstrap capacitor,  $C_{BOOT}$ .
- The bootstrap diode must use a lower forward voltage drop and minimal switching time as soon as possible for fast recovery or ultra-fast diode.

Package Dimensions

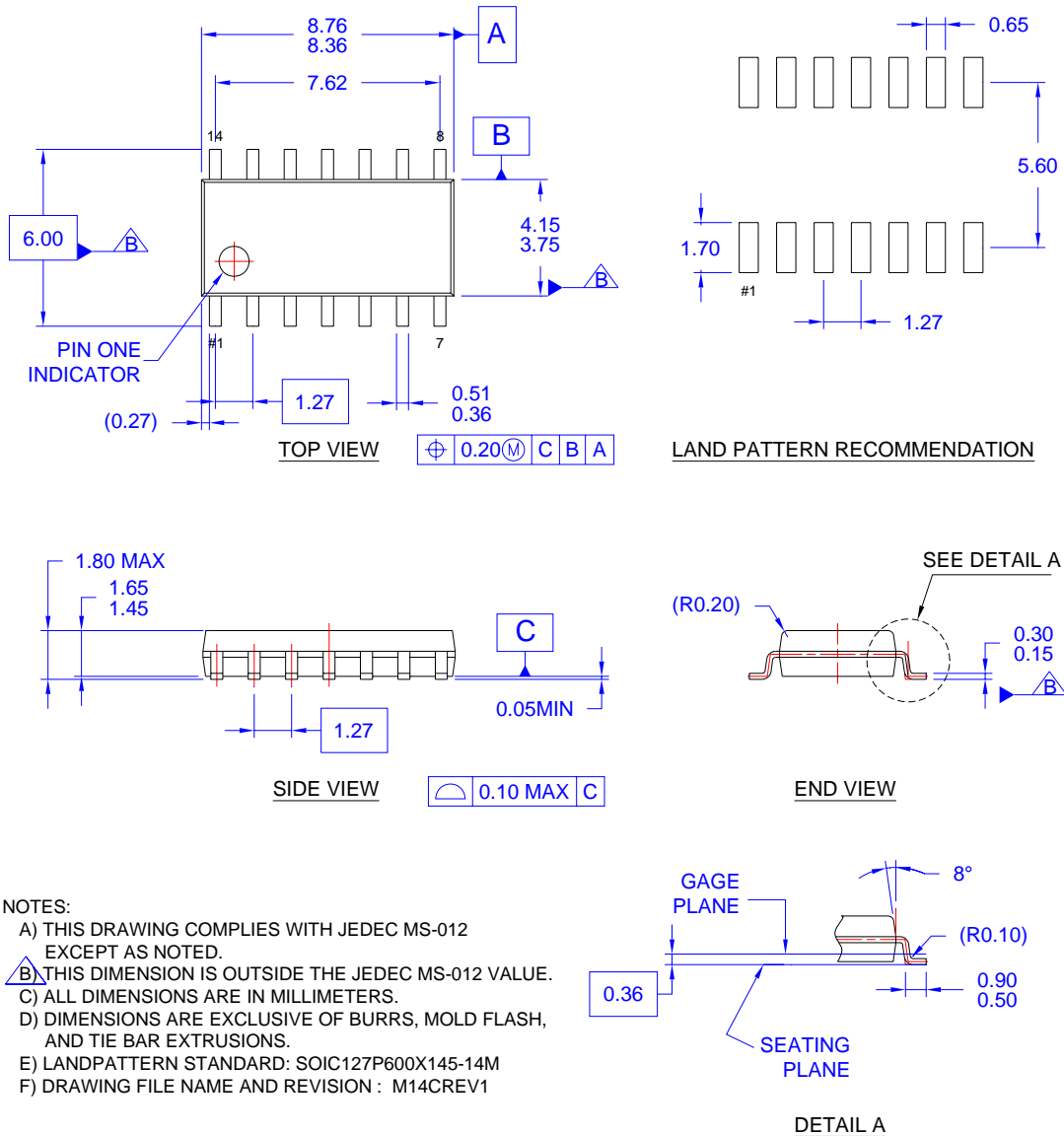

- NOTES:
- A) THIS DRAWING COMPLIES WITH JEDEC MS-012 EXCEPT AS NOTED.
  - B) THIS DIMENSION IS OUTSIDE THE JEDEC MS-012 VALUE.
  - C) ALL DIMENSIONS ARE IN MILLIMETERS.
  - D) DIMENSIONS ARE EXCLUSIVE OF BURRS, MOLD FLASH, AND TIE BAR EXTRUSIONS.
  - E) LANDPATTERN STANDARD: SOIC127P600X145-14M
  - F) DRAWING FILE NAME AND REVISION : M14CREV1

Figure 49. 14-Lead, Small Outline Integrated Circuit (SOIC), Non-JEDEC, .150 Inch Narrow Body, 225SOP

Package drawings are provided as a service to customers considering Fairchild components. Drawings may change in any manner without notice. Please note the revision and/or date on the drawing and contact a Fairchild Semiconductor representative to verify or obtain the most recent revision. Package specifications do not expand the terms of Fairchild's worldwide terms and conditions, specifically the warranty therein, which covers Fairchild products.

Always visit Fairchild Semiconductor's online packaging area for the most recent package drawings:

<http://www.fairchildsemi.com/packaging/>



**TRADEMARKS**

The following includes registered and unregistered trademarks and service marks, owned by Fairchild Semiconductor and/or its global subsidiaries, and is not intended to be an exhaustive list of all such trademarks.

- |                          |                          |                                       |  |
|--------------------------|--------------------------|---------------------------------------|--|
| AccuPower™               | FlashWriter®*            | Power-SPM™                            | <p>SYSTEM GENERAL®<br/>The Power Franchise®</p> <p>the power franchise</p> <p>TinyBoost™</p> <p>TinyBuck™</p> <p>TinyCalc™</p> <p>TinyLogic®</p> <p>TINYOPTO™</p> <p>TinyPower™</p> <p>TinyPWM™</p> <p>TinyWire™</p> <p>TriFault Detect™</p> <p>TRUECURRENT™*</p> <p>μSerDes™</p> <p>SerDes®</p> <p>UHC®</p> <p>Ultra FRFET™</p> <p>UniFET™</p> <p>VCX™</p> <p>VisualMax™</p> <p>XS™</p> |
| Auto-SPM™                | FPST™                    | PowerTrench®                          |  |
| Build it Now™            | F-PFST™                  | PowerXS™                              |  |
| CorePLUS™                | FRFET®                   | Programmable Active Droop™            |  |
| CorePOWER™               | Global Power Resource SM | QFET®                                 |  |
| CROSSVOLT™               | Green FPS™               | QS™                                   |  |
| CTL™                     | Green FPS™ e-Series™     | Quiet Series™                         |  |
| Current Transfer Logic™  | Gmax™                    | RapidConfigure™                       |  |
| DEUXPEED®                | GTO™                     | ™                                     |  |
| Dual Cool™               | IntelliMAX™              | Saving our world, 1mW/W/KW at a time™ |  |
| EcoSPARK®                | ISOPLANAR™               | SignalWise™                           |  |
| EfficientMax™            | MegaBuck™                | SmartMax™                             |  |
| EZSWITCH™*               | MICROCOUPLER™            | SMART START™                          |  |
| ™*                       | MicroFET™                | SPM®                                  |  |
| ®                        | MicroPak™                | STEALTH™                              |  |
| Fairchild®               | MillerDrive™             | SuperFET™                             |  |
| Fairchild Semiconductor® | MotionMax™               | SuperSOT™-3                           |  |
| FACT Quiet Series™       | Motion-SPM™              | SuperSOT™-6                           |  |
| FACT®                    | OPTOLOGIC®               | SuperSOT™-8                           |  |
| FAST®                    | OPTOPLANAR®              | SupreMOS™                             |  |
| FastvCore™               | ®                        | SyncFET™                              |  |
| FETBench™                | PDP SPM™                 | Sync-Lock™                            |  |

\* Trademarks of System General Corporation, used under license by Fairchild Semiconductor.

**DISCLAIMER**

FAIRCHILD SEMICONDUCTOR RESERVES THE RIGHT TO MAKE CHANGES WITHOUT FURTHER NOTICE TO ANY PRODUCTS HEREIN TO IMPROVE RELIABILITY, FUNCTION, OR DESIGN. FAIRCHILD DOES NOT ASSUME ANY LIABILITY ARISING OUT OF THE APPLICATION OR USE OF ANY PRODUCT OR CIRCUIT DESCRIBED HEREIN; NEITHER DOES IT CONVEY ANY LICENSE UNDER ITS PATENT RIGHTS, NOR THE RIGHTS OF OTHERS. THESE SPECIFICATIONS DO NOT EXPAND THE TERMS OF FAIRCHILD'S WORLDWIDE TERMS AND CONDITIONS, SPECIFICALLY THE WARRANTY THEREIN, WHICH COVERS THESE PRODUCTS.

**LIFE SUPPORT POLICY**

FAIRCHILD'S PRODUCTS ARE NOT AUTHORIZED FOR USE AS CRITICAL COMPONENTS IN LIFE SUPPORT DEVICES OR SYSTEMS WITHOUT THE EXPRESS WRITTEN APPROVAL OF FAIRCHILD SEMICONDUCTOR CORPORATION.

As used herein:

- Life support devices or systems are devices or systems which, (a) are intended for surgical implant into the body or (b) support or sustain life, and (c) whose failure to perform when properly used in accordance with instructions for use provided in the labeling, can be reasonably expected to result in a significant injury of the user.
- A critical component in any component of a life support, device, or system whose failure to perform can be reasonably expected to cause the failure of the life support device or system, or to affect its safety or effectiveness.

**ANTI-COUNTERFEITING POLICY**

Fairchild Semiconductor Corporation's Anti-Counterfeiting Policy. Fairchild's Anti-Counterfeiting Policy is also stated on our external website, [www.fairchildsemi.com](http://www.fairchildsemi.com), under Sales Support.

Counterfeiting of semiconductor parts is a growing problem in the industry. All manufacturers of semiconductor products are experiencing counterfeiting of their parts. Customers who inadvertently purchase counterfeit parts experience many problems such as loss of brand reputation, substandard performance, failed applications, and increased cost of production and manufacturing delays. Fairchild is taking strong measures to protect ourselves and our customers from the proliferation of counterfeit parts. Fairchild strongly encourages customers to purchase Fairchild parts either directly from Fairchild or from Authorized Fairchild Distributors who are listed by country on our web page cited above. Products customers buy either from Fairchild directly or from Authorized Fairchild Distributors are genuine parts, have full traceability, meet Fairchild's quality standards for handling and storage and provide access to Fairchild's full range of up-to-date technical and product information. Fairchild and our Authorized Distributors will stand behind all warranties and will appropriately address any warranty issues that may arise. Fairchild will not provide any warranty coverage or other assistance for parts bought from Unauthorized Sources. Fairchild is committed to combat this global problem and encourage our customers to do their part in stopping this practice by buying direct or from authorized distributors.

**PRODUCT STATUS DEFINITIONS**



**Definition of Terms**

Datasheet Identification	Product Status	Definition
Advance Information	Formative / In Design	Datasheet contains the design specifications for product development. Specifications may change in any manner without notice.
Preliminary	First Production	Datasheet contains preliminary data; supplementary data will be published at a later date. Fairchild Semiconductor reserves the right to make changes at any time without notice to improve design.
No Identification Needed	Full Production	Datasheet contains final specifications. Fairchild Semiconductor reserves the right to make changes at any time without notice to improve the design.
Obsolete	Not In Production	Datasheet contains specifications on a product that is discontinued by Fairchild Semiconductor. The datasheet is for reference information only.

Rev. I45

## Looking for pricing, stock, or lifecycle information?

Click below to explore more details on WIN SOURCE:

-  [View FAN7393MX on WIN SOURCE](#)
-  [Fairchild/ON Semiconductor Information](#)

## Optimize Your Supply Chain with WIN SOURCE Solutions

-  Global Sourcing Solution
-  Obsolete Management
-  Cost Control Management
-  Shortage Management
-  Alternative Solution
-  Excess Inventory Management