



# THE DATASHEET OF ADG604YRU





# 1 pC Charge Injection, 100 pA Leakage CMOS $\pm 5$ V/5 V/3 V 4-Channel Multiplexer

## ADG604

### FEATURES

- 1 pC Charge Injection (Over the Full Signal Range)
- $\pm 2.7$  V to  $\pm 5.5$  V Dual Supply
- 2.7 V to 5.5 V Single Supply
- Temperature Range:  $-40^{\circ}\text{C}$  to  $+125^{\circ}\text{C}$
- 100 pA Max @  $25^{\circ}\text{C}$  Leakage Currents
- 85  $\Omega$  Typ On Resistance
- Rail-to-Rail Operation
- Fast Switching Times
- Typical Power Consumption ( $<0.1 \mu\text{W}$ )
- TTL/CMOS Compatible Inputs
- 14-Lead TSSOP Package

### APPLICATIONS

- Automatic Test Equipment
- Data Acquisition Systems
- Battery-Powered Instruments
- Communication Systems
- Sample and Hold Systems
- Remote-Powered Equipment
- Audio and Video Signal Routing
- Relay Replacement
- Avionics

### GENERAL DESCRIPTION

The ADG604 is a CMOS analog multiplexer, comprising four single channels. It operates from a dual supply of  $\pm 2.7$  V to  $\pm 5.5$  V, or from a single supply of 2.7 V to 5.5 V.

The ADG604 switches one of four inputs to a common output, D, as determined by the 3-bit binary address lines, A0, A1, and EN. A Logic "0" on the EN pin disables the device.

The ADG604 offers ultralow charge injection of  $\pm 1.5$  pC over the entire signal range and leakage currents of 10 pA typical at  $25^{\circ}\text{C}$ . It offers on resistance of 85  $\Omega$  typ, which is matched to within 2  $\Omega$  between channels. The ADG604 also has low power dissipation yet gives high switching speeds. The ADG604 is available in a 14-lead TSSOP package.

### FUNCTIONAL BLOCK DIAGRAM

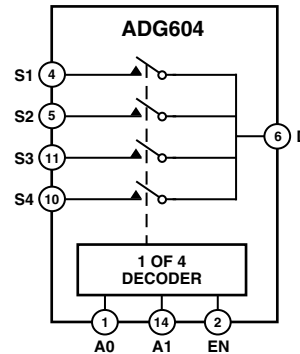

### PRODUCT HIGHLIGHTS

1. Ultralow Charge Injection ( $Q_{\text{INJ}}$ :  $\pm 1.5$  pC Typ over the Full Signal Range)
2. Leakage Current  $<0.5$  nA max @  $85^{\circ}\text{C}$
3. Dual  $\pm 2.7$  V to  $\pm 5.5$  V or Single 2.7 V to 5.5 V Supply
4. Fully Specified to  $125^{\circ}\text{C}$
5. Small 14-Lead TSSOP Package

REV. A

[Document Feedback](#)

Information furnished by Analog Devices is believed to be accurate and reliable. However, no responsibility is assumed by Analog Devices for its use, nor for any infringements of patents or other rights of third parties that may result from its use. No license is granted by implication or otherwise under any patent or patent rights of Analog Devices.

One Technology Way, P.O. Box 9106, Norwood, MA 02062-9106, U.S.A.  
Tel: 781.329.4700 ©2018 Analog Devices, Inc. All rights reserved.  
[Technical Support](#) [www.analog.com](http://www.analog.com)

# ADG604—SPECIFICATIONS

## DUAL SUPPLY<sup>1</sup> ( $V_{DD} = +5\text{ V} \pm 10\%$ , $V_{SS} = -5\text{ V} \pm 10\%$ , $GND = 0\text{ V}$ . All specifications $-40^\circ\text{C}$ to $+125^\circ\text{C}$ unless otherwise noted.)

Parameter	25°C	-40°C to +85°C	-40°C to +125°C	Unit	Test Conditions/Comments
<b>ANALOG SWITCH</b>					
Analog Signal Range			$V_{SS}$ to $V_{DD}$	V	
On Resistance ( $R_{ON}$ )	85 115	140	160	$\Omega$ Typ $\Omega$ Max	$V_{DD} = +4.5\text{ V}$ , $V_{SS} = -4.5\text{ V}$ $V_S = \pm 3\text{ V}$ , $I_S = -1\text{ mA}$ , Test Circuit 1
On Resistance Match Between Channels ( $\Delta R_{ON}$ )	2 4	5.5	6.5	$\Omega$ Typ $\Omega$ Max	$V_S = \pm 3\text{ V}$ , $I_S = -1\text{ mA}$
On-Resistance Flatness ( $R_{FLAT(ON)}$ )	25 40	55	60	$\Omega$ Typ $\Omega$ Max	$V_S = \pm 3\text{ V}$ , $I_S = -1\text{ mA}$
<b>LEAKAGE CURRENTS</b>					
Source OFF Leakage $I_S$ (OFF)	$\pm 0.01$ $\pm 0.1$	$\pm 0.25$	$\pm 4$	nA Typ nA Max	$V_{DD} = +5.5\text{ V}$ , $V_{SS} = -5.5\text{ V}$ $V_S = \pm 4.5\text{ V}$ , $V_D = \mp 4.5\text{ V}$ , Test Circuit 2
Drain OFF Leakage $I_D$ (OFF)	$\pm 0.01$ $\pm 0.1$	$\pm 0.5$	$\pm 8$	nA Typ nA Max	$V_S = \pm 4.5\text{ V}$ , $V_D = \mp 4.5\text{ V}$ , Test Circuit 2
Channel ON Leakage $I_D$ , $I_S$ (ON)	$\pm 0.01$ $\pm 0.1$	$\pm 0.5$	$\pm 10$	nA Typ nA Max	$V_S = V_D = \pm 4.5\text{ V}$ , Test Circuit 3
<b>DIGITAL INPUTS</b>					
Input High Voltage, $V_{INH}$			2.4	V Min	
Input Low Voltage, $V_{INL}$			0.8	V Max	
Input Current $I_{INL}$ or $I_{INH}$	0.005		$\pm 0.1$	$\mu\text{A}$ Typ $\mu\text{A}$ Max	$V_{IN} = V_{INL}$ or $V_{INH}$
$C_{IN}$ , Digital Input Capacitance	2			pF Typ	
<b>DYNAMIC CHARACTERISTICS</b>					
Transition Time	70 100	120	150	ns Typ ns Max	$V_{S1} = +3\text{ V}$ , $V_{S4} = -3\text{ V}$ , $R_L = 300\ \Omega$ , $C_L = 35\text{ pF}$ , Test Circuit 4
$t_{ON}$ Enable	80 105	130	150	ns Typ ns Max	$R_L = 300\ \Omega$ , $C_L = 35\text{ pF}$ $V_S = 3\text{ V}$ , Test Circuit 6
$t_{OFF}$ Enable	30 45	55	65	ns Typ ns Max	$R_L = 300\ \Omega$ , $C_L = 35\text{ pF}$ $V_S = 3\text{ V}$ , Test Circuit 6
Break-Before-Make Time Delay, $t_{BBM}$	20		10	ns Typ ns Min	$R_L = 300\ \Omega$ , $C_L = 35\text{ pF}$ , $V_{S1} = V_{S2} = 3\text{ V}$ , Test Circuit 5
Charge Injection	-1			pC Typ	$V_S = 0\text{ V}$ , $R_S = 0\ \Omega$ , $C_L = 1\text{ nF}$ , Test Circuit 7
Off Isolation	-75			dB Typ	$R_L = 50\ \Omega$ , $C_L = 5\text{ pF}$ , $f = 10\text{ MHz}$ , Test Circuit 8
Channel-to-Channel Crosstalk	-70			dB Typ	$R_L = 50\ \Omega$ , $C_L = 5\text{ pF}$ , $f = 10\text{ MHz}$ , Test Circuit 10
Bandwidth -3 dB	280			MHz Typ	$R_L = 50\ \Omega$ , $C_L = 5\text{ pF}$ , Test Circuit 9
$C_S$ (OFF)	5			pF Typ	$f = 1\text{ MHz}$
$C_D$ (OFF)	17			pF Typ	$f = 1\text{ MHz}$
$C_D$ , $C_S$ (ON)	18			pF Typ	$f = 1\text{ MHz}$
<b>POWER REQUIREMENTS</b>					
$I_{DD}$	0.001		1.0	$\mu\text{A}$ Typ $\mu\text{A}$ Max	$V_{DD} = +5.5\text{ V}$ , $V_{SS} = -5.5\text{ V}$ Digital Inputs = 0 V or 5.5 V
$I_{SS}$	0.001		1.0	$\mu\text{A}$ Typ $\mu\text{A}$ Max	Digital Inputs = 0 V or 5.5 V

### NOTES

<sup>1</sup>Y Version Temperature Range:  $-40^\circ\text{C}$  to  $+125^\circ\text{C}$ .

Specifications subject to change without notice.

**SINGLE SUPPLY<sup>1</sup>** ( $V_{DD} = 5\text{ V} \pm 10\%$ ,  $V_{SS} = 0\text{ V}$ ,  $GND = 0\text{ V}$ . All specifications  $-40^{\circ}\text{C}$  to  $+125^{\circ}\text{C}$  unless otherwise noted.)

Parameter	25°C	-40°C to +85°C	-40°C to +125°C	Unit	Test Conditions/Comments
<b>ANALOG SWITCH</b>					
Analog Signal Range			0 V to $V_{DD}$	V	
On Resistance ( $R_{ON}$ )	210 290	350	380	$\Omega$ Typ $\Omega$ Max	$V_{DD} = 4.5\text{ V}$ , $V_{SS} = 0\text{ V}$ $V_S = 3.5\text{ V}$ , $I_S = -1\text{ mA}$ , Test Circuit 1
On Resistance Match Between Channels ( $\Delta R_{ON}$ )	3	12	13	$\Omega$ Typ $\Omega$ Max	$V_S = 3.5\text{ V}$ , $I_S = -1\text{ mA}$
<b>LEAKAGE CURRENTS</b>					
Source OFF Leakage $I_S$ (OFF)	$\pm 0.01$ $\pm 0.1$	$\pm 0.25$	$\pm 4$	nA Typ nA Max	$V_{DD} = 5.5\text{ V}$ $V_S = 1\text{ V}/4.5\text{ V}$ , $V_D = 4.5\text{ V}/1\text{ V}$ , Test Circuit 2
Drain OFF Leakage $I_D$ (OFF)	$\pm 0.01$ $\pm 0.1$	$\pm 0.5$	$\pm 8$	nA Typ nA Max	$V_S = 1\text{ V}/4.5\text{ V}$ , $V_D = 4.5\text{ V}/1\text{ V}$ , Test Circuit 2
Channel ON Leakage $I_D$ , $I_S$ (ON)	$\pm 0.01$ $\pm 0.1$	$\pm 0.5$	10	nA Typ nA Max	$V_S = V_D = 4.5\text{ V}/1\text{ V}$ , Test Circuit 3
<b>DIGITAL INPUTS</b>					
Input High Voltage, $V_{INH}$			2.4	V Min	
Input Low Voltage, $V_{INL}$			0.8	V Max	
Input Current $I_{INL}$ or $I_{INH}$	0.005		$\pm 0.1$	$\mu\text{A}$ Typ $\mu\text{A}$ Max	$V_{IN} = V_{INL}$ or $V_{INH}$
$C_{IN}$ , Digital Input Capacitance	2			pF Typ	
<b>DYNAMIC CHARACTERISTICS</b>					
Transition Time	90 150	185	210	ns Typ ns Max	$V_{S1} = 3\text{ V}$ , $V_{S4} = 0\text{ V}$ , $R_L = 300\ \Omega$ , $C_L = 35\text{ pF}$ , Test Circuit 4
$t_{ON}$ Enable	105 150	190	220	ns Typ ns Max	$R_L = 300\ \Omega$ , $C_L = 35\text{ pF}$ $V_S = 3\text{ V}$ , Test Circuit 6
$t_{OFF}$ Enable	45 70	80	90	ns Typ ns Max	$R_L = 300\ \Omega$ , $C_L = 35\text{ pF}$ $V_S = 3\text{ V}$ , Test Circuit 6
Break-Before-Make Time Delay, $t_{BBM}$	30		10	ns Typ ns Min	$R_L = 300\ \Omega$ , $C_L = 35\text{ pF}$ , $V_{S1} = V_{S2} = 3\text{ V}$ , Test Circuit 5
Charge Injection	0.3			pC Typ	$V_S = 0\text{ V}$ , $R_S = 0\ \Omega$ , $C_L = 1\text{ nF}$ , Test Circuit 7
Off Isolation	-65			dB Typ	$R_L = 50\ \Omega$ , $C_L = 5\text{ pF}$ , $f = 10\text{ MHz}$ , Test Circuit 8
Channel-to-Channel Crosstalk	-70			dB Typ	$R_L = 50\ \Omega$ , $C_L = 5\text{ pF}$ , $f = 10\text{ MHz}$ , Test Circuit 10
Bandwidth -3 dB	250			MHz Typ	$R_L = 50\ \Omega$ , $C_L = 5\text{ pF}$ , Test Circuit 9
$C_S$ (OFF)	5			pF Typ	$f = 1\text{ MHz}$
$C_D$ (OFF)	17			pF Typ	$f = 1\text{ MHz}$
$C_D$ , $C_S$ (ON)	18			pF Typ	$f = 1\text{ MHz}$
<b>POWER REQUIREMENTS</b>					
$I_{DD}$	0.001		1.0	$\mu\text{A}$ Typ $\mu\text{A}$ Max	$V_{DD} = 5.5\text{ V}$ Digital Inputs = 0 V or 5.5 V

## NOTES

<sup>1</sup>Y Version Temperature Range:  $-40^{\circ}\text{C}$  to  $+125^{\circ}\text{C}$ .

Specifications subject to change without notice.

# ADG604—SPECIFICATIONS

## SINGLE SUPPLY<sup>1</sup>

( $V_{DD} = 3\text{ V} \pm 10\%$ ,  $V_{SS} = 0\text{ V}$ ,  $GND = 0\text{ V}$ . All specifications  $-40^{\circ}\text{C}$  to  $+125^{\circ}\text{C}$  unless otherwise noted.)

Parameter	25°C	-40°C to +85°C	-40°C to +125°C	Unit	Test Conditions/Comments
<b>ANALOG SWITCH</b>					
Analog Signal Range			0 V to $V_{DD}$	V	
On Resistance ( $R_{ON}$ )	380	420	460	$\Omega$ Typ	$V_{DD} = 2.7\text{ V}$ , $V_{SS} = 0\text{ V}$ $V_S = 1.5\text{ V}$ , $I_S = -1\text{ mA}$ , Test Circuit 1
On Resistance Match Between Channels ( $\Delta R_{ON}$ )			5	$\Omega$ Typ	$V_S = 1.5\text{ V}$ , $I_S = -1\text{ mA}$
<b>LEAKAGE CURRENTS</b>					
Source OFF Leakage $I_S$ (OFF)	$\pm 0.01$ $\pm 0.1$	$\pm 0.25$	$\pm 4$	nA Typ nA Max	$V_{DD} = 3.3\text{ V}$ $V_S = 1\text{ V}/3\text{ V}$ , $V_D = 3\text{ V}/1\text{ V}$ , Test Circuit 2
Drain OFF Leakage $I_D$ (OFF)	$\pm 0.01$ $\pm 0.1$	$\pm 0.5$	$\pm 8$	nA Typ nA Max	$V_S = 1\text{ V}/3\text{ V}$ , $V_D = 3\text{ V}/1\text{ V}$ , Test Circuit 2
Channel ON Leakage $I_D$ , $I_S$ (ON)	$\pm 0.01$ $\pm 0.1$	$\pm 0.5$	$\pm 10$	nA Typ nA Max	$V_S = V_D = 1\text{ V}/3\text{ V}$ , Test Circuit 3
<b>DIGITAL INPUTS</b>					
Input High Voltage, $V_{INH}$			2.0	V Min	
Input Low Voltage, $V_{INL}$			0.8	V Max	
Input Current $I_{INL}$ or $I_{INH}$	0.005		$\pm 0.1$	$\mu\text{A}$ Typ $\mu\text{A}$ Max	$V_{IN} = V_{INL}$ or $V_{INH}$
$C_{IN}$ , Digital Input Capacitance	2			pF Typ	
<b>DYNAMIC CHARACTERISTICS</b>					
Transition Time	170 320	390	450	ns Typ ns Max	$V_{S1} = 2\text{ V}$ , $V_{S4} = 0\text{ V}$ , $R_L = 300\ \Omega$ , $C_L = 35\text{ pF}$ , Test Circuit 4
$t_{ON}$ Enable	180 250	265	390	ns Typ ns Max	$R_L = 300\ \Omega$ , $C_L = 35\text{ pF}$ $V_S = 2\text{ V}$ , Test Circuit 6
$t_{OFF}$ Enable	100 160	205	225	ns Typ ns Max	$R_L = 300\ \Omega$ , $C_L = 35\text{ pF}$ $V_S = 2\text{ V}$ , Test Circuit 6
Break-Before-Make Time Delay, $t_{BBM}$	100		10	ns Typ ns Min	$R_L = 300\ \Omega$ , $C_L = 35\text{ pF}$ , $V_{S1} = V_{S2} = 2\text{ V}$ , Test Circuit 5
Charge Injection	0.3			pC Typ	$V_S = 0\text{ V}$ to $3.3\text{ V}$ , $R_S = 0\ \Omega$ , $C_L = 1\ \mu\text{F}$ , Test Circuit 7
Off Isolation	-65			dB Typ	$R_L = 50\ \Omega$ , $C_L = 5\text{ pF}$ , $f = 10\text{ MHz}$ , Test Circuit 8
Channel-to-Channel Crosstalk	70			dB Typ	$R_L = 50\ \Omega$ , $C_L = 5\text{ pF}$ , $f = 10\text{ MHz}$ , Test Circuit 10
Bandwidth -3 dB	250			MHz Typ	$R_L = 50\ \Omega$ , $C_L = 5\text{ pF}$ , Test Circuit 9
$C_S$ (OFF)	5			pF Typ	$f = 1\text{ MHz}$
$C_D$ (OFF)	17			pF Typ	$f = 1\text{ MHz}$
$C_D$ , $C_S$ (ON)	18			pF Typ	$f = 1\text{ MHz}$
<b>POWER REQUIREMENTS</b>					
$I_{DD}$	0.001		1.0	$\mu\text{A}$ Typ $\mu\text{A}$ Max	$V_{DD} = 3.3\text{ V}$ Digital Inputs = 0 V or 3.3 V

### NOTES

<sup>1</sup>Y Version Temperature Range:  $-40^{\circ}\text{C}$  to  $+125^{\circ}\text{C}$ .

Specifications subject to change without notice.

## ABSOLUTE MAXIMUM RATINGS<sup>1</sup>

(T<sub>A</sub> = 25°C unless otherwise noted)

V <sub>DD</sub> to V <sub>SS</sub> .....	13 V
V <sub>DD</sub> to GND .....	-0.3 V to +6.5 V
V <sub>SS</sub> to GND .....	+0.3 V to -6.5 V
Analog Inputs <sup>2</sup> .....	V <sub>SS</sub> - 0.3 V to V <sub>DD</sub> + 0.3 V
Digital Inputs <sup>2</sup> .....	-0.3 V to V <sub>DD</sub> + 0.3 V or ..... 30 mA, Whichever Occurs First
Peak Current, S or D .....	20 mA (Pulsed at 1 ms, 10% Duty Cycle Max)
Continuous Current, S or D .....	10 mA
Operating Temperature Range (Y Version) .....	-40°C to +125°C
Storage Temperature Range .....	-65°C to +150°C

Junction Temperature .....	150°C
TSSOP Package θ <sub>JA</sub> Thermal Impedance .....	150°C/W
θ <sub>JC</sub> Thermal Impedance .....	27°C/W
Lead Temperature, Soldering (10 seconds) .....	300°C
IR Reflow, Peak Temperature .....	220°C

### NOTES

<sup>1</sup>Stresses above those listed under Absolute Maximum Ratings may cause permanent damage to the device. This is a stress rating only; functional operation of the device at these or any other conditions above those listed in the operational sections of this specification is not implied. Exposure to absolute maximum rating conditions for extended periods may affect device reliability. Only one absolute maximum rating may be applied at any one time.

<sup>2</sup>Overvoltages at EN, A0, A1, S, or D will be clamped by internal diodes. Current should be limited to the maximum ratings given.

## PIN CONFIGURATION

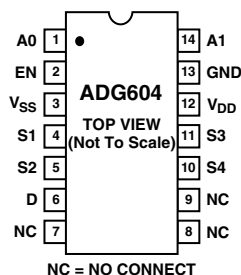

**Table I. Truth Table**

A1	A0	EN	ON Switch
X	X	0	None
0	0	1	1
0	1	1	2
1	0	1	3
1	1	1	4

## CAUTION

ESD (electrostatic discharge) sensitive device. Electrostatic charges as high as 4000 V readily accumulate on the human body and test equipment and can discharge without detection. Although the ADG604 features proprietary ESD protection circuitry, permanent damage may occur on devices subjected to high-energy electrostatic discharges. Therefore, proper ESD precautions are recommended to avoid performance degradation or loss of functionality.



## TERMINOLOGY

$V_{DD}$	Most Positive Power Supply Potential
$V_{SS}$	Most Negative Power Supply in a Dual Supply Application. In single supply applications, this should be tied to ground at the device.
GND	Ground (0 V) Reference
$I_{DD}$	Positive Supply Current
$I_{SS}$	Negative Supply Current
S	Source Terminal. May be an input or output.
D	Drain Terminal. May be an input or output.
$R_{ON}$	Ohmic Resistance between D and S
$\Delta R_{ON}$	On Resistance Match between any two channels, i.e., $R_{ON\ Max} - R_{ON\ Min}$
$R_{FLAT(ON)}$	Flatness is defined as the difference between the maximum and minimum value of On resistance as measured over the specified analog signal range.
$I_S$ (OFF)	Source Leakage Current with the Switch "OFF"
$I_D$ (OFF)	Drain Leakage Current with the Switch "OFF"
$I_D, I_S$ (ON)	Channel Leakage Current with the Switch "ON"
$V_D, V_S$	Analog Voltage on Terminals D, S
$V_{INL}$	Maximum Input Voltage for Logic "0"
$V_{INH}$	Minimum Input Voltage for Logic "1"
$I_{INL}$ ( $I_{INH}$ )	Input Current of the Digital Input
$C_S$ (OFF)	Channel Input Capacitance for "OFF" Condition
$C_D$ (OFF)	Channel Output Capacitance for "OFF" Condition
$C_D, C_S$ (ON)	"On" Switch Capacitance
$C_{IN}$	Digital Input Capacitance
$t_{ON}$ (EN)	Delay time between the 50% and 90% points of the digital input and switch "ON" condition.
$t_{OFF}$ (EN)	Delay time between the 50% and 90% points of the digital input and switch "OFF" condition.
$t_{TRANSITION}$	Delay time between the 50% and 90% points of the digital input and switch "ON" condition when switching from one address state to another.
$t_{BBM}$	"OFF" time or "ON" time measured between the 80% points of both switches, when switching from one address state to another.
Charge Injection	A measure of the glitch impulse transferred from the digital input to the analog output during switching.
Crosstalk	A measure of unwanted signal that is coupled through from one channel to another as a result of parasitic capacitance.
Off Isolation	A measure of unwanted signal coupling through an "On" switch.
Bandwidth	Frequency Response of the "On" Switch
Insertion Loss	Loss Due to the On Resistance of the Switch

# Typical Performance Characteristics—ADG604

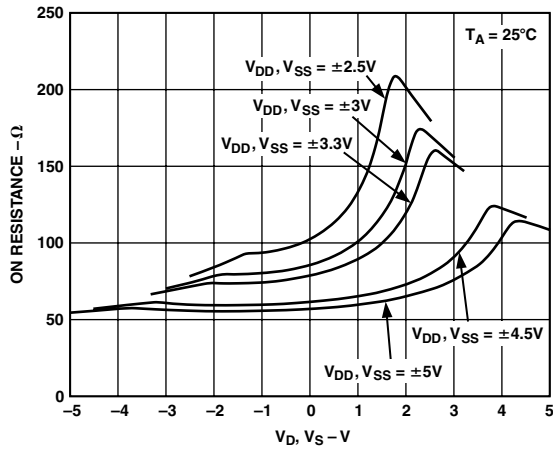

TPC 1. On Resistance vs.  $V_D$  ( $V_S$ ), Dual Supply

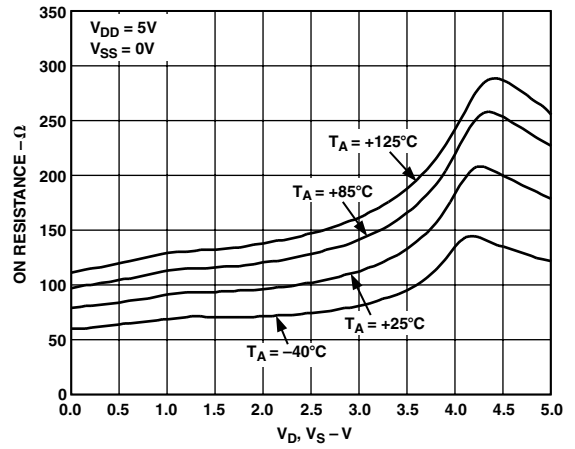

TPC 4. On Resistance vs.  $V_D$  ( $V_S$ ) for Different Temperatures, Single Supply

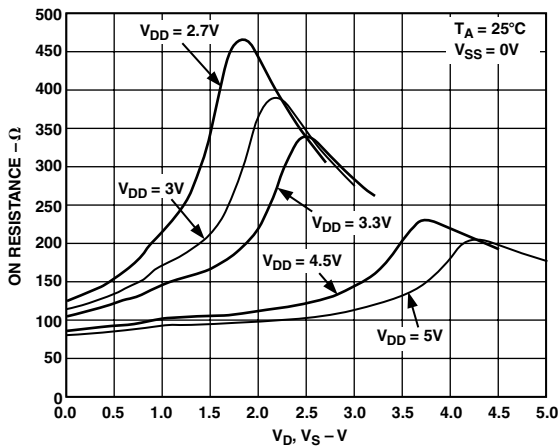

TPC 2. On Resistance vs.  $V_D$  ( $V_S$ ), Single Supply

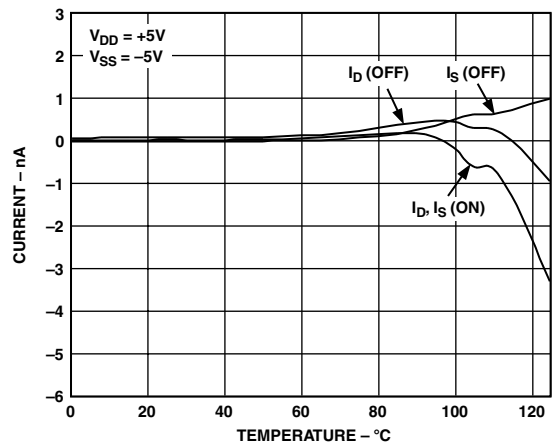

TPC 5. Leakage Currents vs. Temperature, Dual Supply

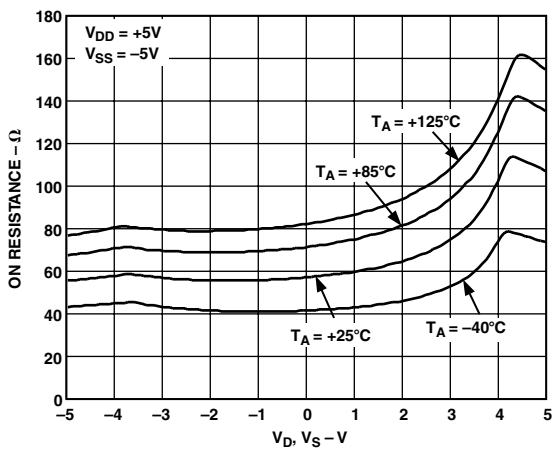

TPC 3. On Resistance vs.  $V_D$  ( $V_S$ ) for Different Temperatures, Dual Supply

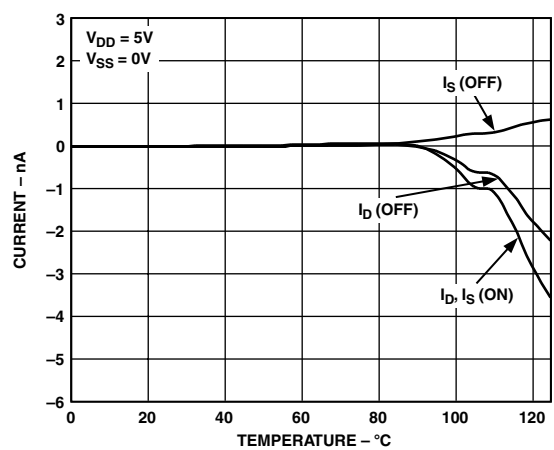

TPC 6. Leakage Currents vs. Temperature, Single Supply

# ADG604

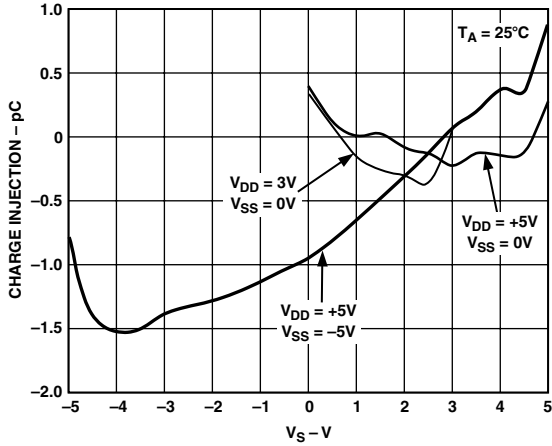

TPC 7. Charge Injection vs. Source Voltage

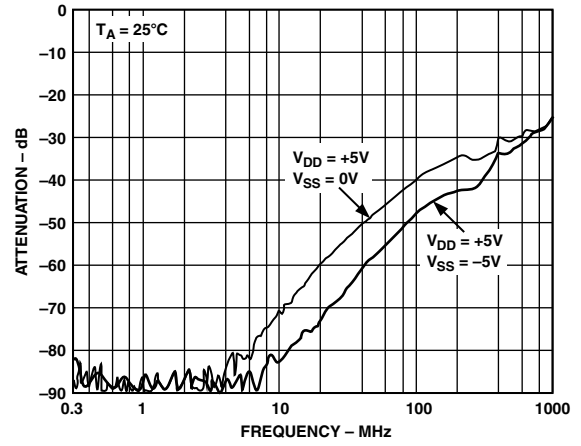

TPC 10. Crosstalk vs. Frequency

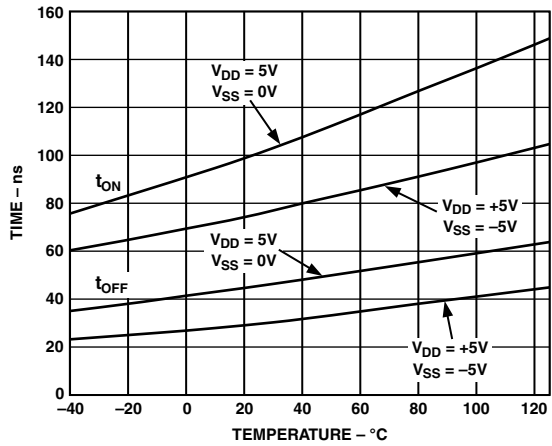

TPC 8.  $t_{ON}/t_{OFF}$  Times vs. Temperature

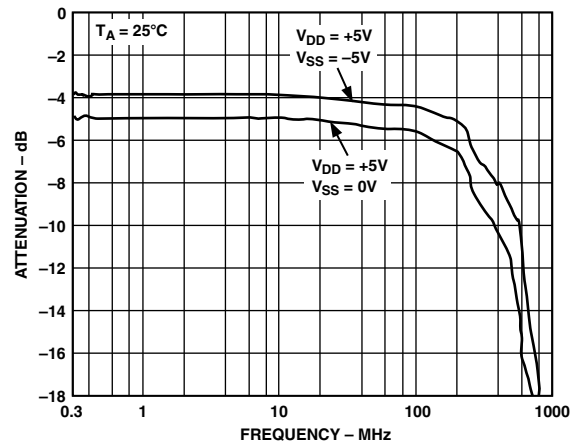

TPC 11. On Response vs. Frequency

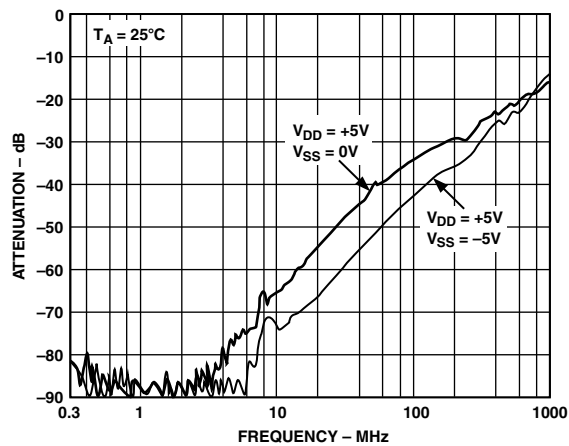

TPC 9. Off Isolation vs. Frequency

# Test Circuits

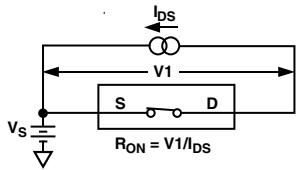

Test Circuit 1. On Resistance

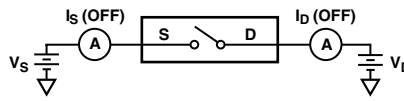

Test Circuit 2. Off Leakage

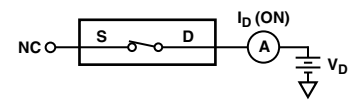

Test Circuit 3. On Leakage

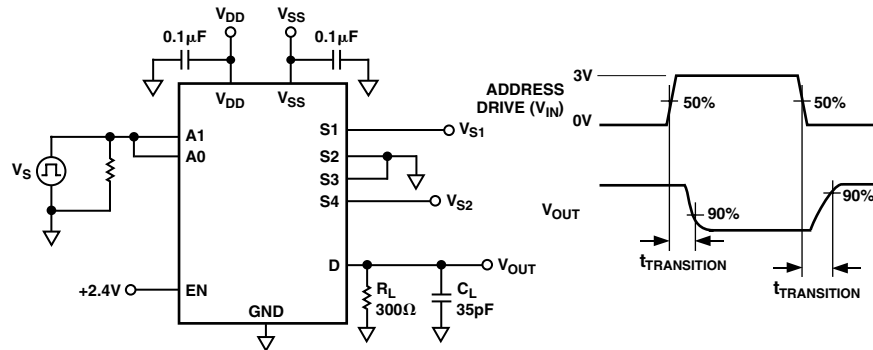

Test Circuit 4. Switching Time of Multiplexer,  $t_{TRANSITION}$

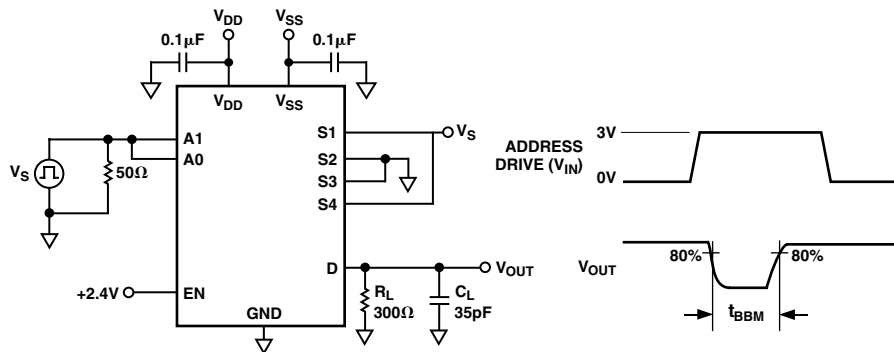

Test Circuit 5. Break-Before-Make Delay,  $t_{BBM}$

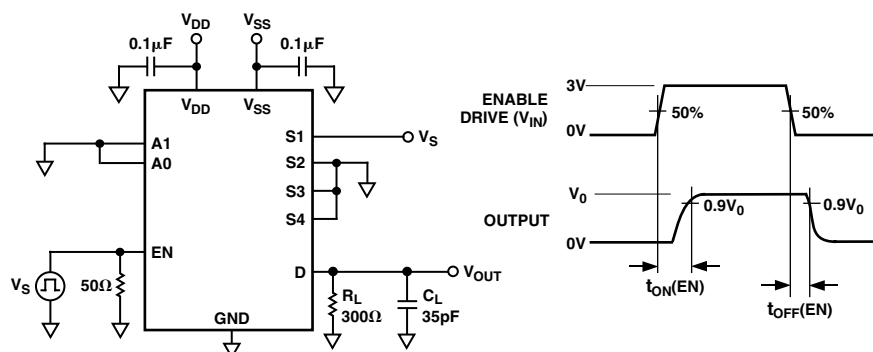

Test Circuit 6. Enable Delay,  $t_{ON}(EN)$ ,  $t_{OFF}(EN)$

# ADG604

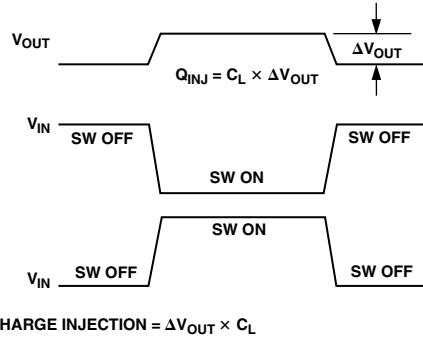
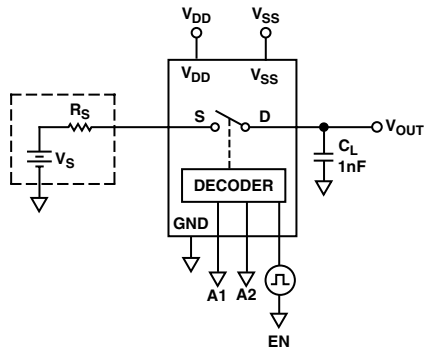

Test Circuit 7. Charge Injection

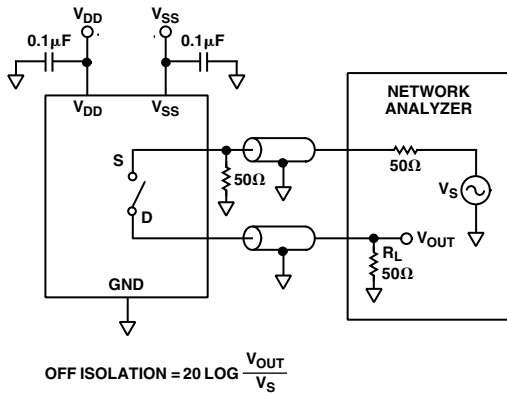

$$\text{OFF ISOLATION} = 20 \text{ LOG} \frac{V_{\text{OUT}}}{V_S}$$

Test Circuit 8. Off Isolation

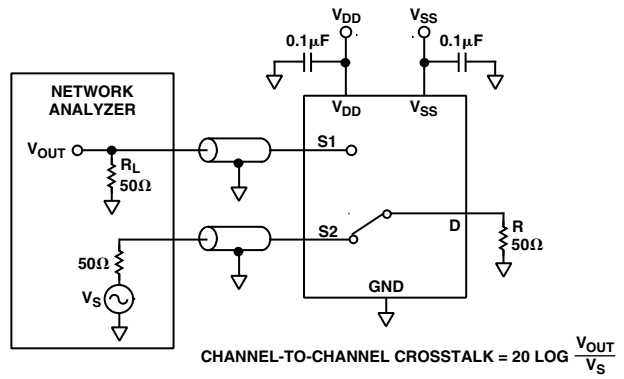

$$\text{CHANNEL-TO-CHANNEL CROSSTALK} = 20 \text{ LOG} \frac{V_{\text{OUT}}}{V_S}$$

Test Circuit 10. Channel-to-Channel Crosstalk

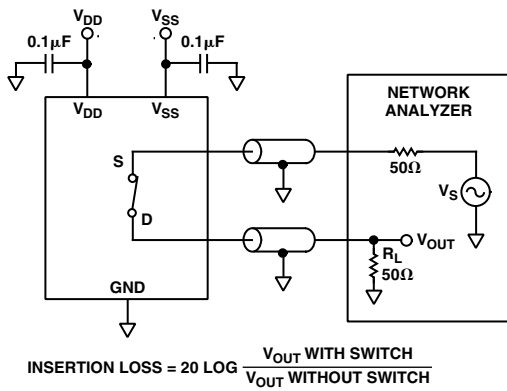

$$\text{INSERTION LOSS} = 20 \text{ LOG} \frac{V_{\text{OUT WITH SWITCH}}}{V_{\text{OUT WITHOUT SWITCH}}}$$

Test Circuit 9. Bandwidth

### OUTLINE DIMENSIONS

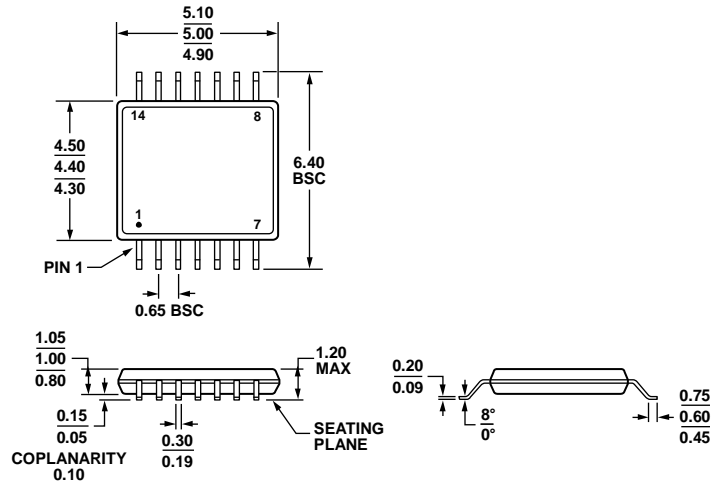

COMPLIANT TO JEDEC STANDARDS MO-153-AB-1

Figure 1. 14-Lead Thin Shrink Small Outline Package [TSSOP] (RU-14)

Dimensions shown in millimeters

### ORDERING GUIDE

Model <sup>1</sup>	Temperature Range	Package Description	Package Option
ADG604YRUZ	-40°C to +125°C	14-Lead Thin Shrink Small Outline Package [TSSOP]	RU-14
ADG604YRUZ-REEL7	-40°C to +125°C	14-Lead Thin Shrink Small Outline Package [TSSOP]	RU-14

<sup>1</sup> Z = RoHS Compliant Part.

### REVISION HISTORY

#### 7/2018—Rev. 0 to Rev. A

Changed Automotive Temperature Range: -40°C to +125°C to Temperature Range: -40°C to +125°C.....	1
Deleted Note 2, Dual Supply Table; Renumbered Sequentially .....	2
Deleted Note 2, Single Supply Table; Renumbered Sequentially .....	3
Deleted Note 2, Single Supply Table; Renumbered Sequentially .....	4
Changed Operating Temperature Range, Automotive (Y Version) to Operating Temperature Range, (Y Version); Absolute Maximum Ratings Table .....	5
Updated Outline Dimensions.....	11
Moved Ordering Guide .....	11
Changes to Ordering Guide.....	11

#### 2/2002—Revision 0: Initial Version

## Looking for pricing, stock, or lifecycle information?

Click below to explore more details on WIN SOURCE:

 [View ADG604YRU on WIN SOURCE](#)

 [Analog Devices Inc. Information](#)

## Optimize Your Supply Chain with WIN SOURCE Solutions

-  Global Sourcing Solution
-  Obsolete Management
-  Cost Control Management
-  Shortage Management
-  Alternative Solution
-  Excess Inventory Management