



THE DATASHEET OF OPA317IDBVR



OPAx317 Zero-Drift, Low-Offset, Rail-to-Rail I/O Operational Amplifier Precision Catalog

1 Features

- Supply Voltage: 1.8 V to 5.5 V
- microPackages:
 - Single: SOT23-5, SC-70, SOIC-8
 - Dual: VSSOP-8, SOIC-8
 - Quad: SOIC-14, TSSOP-14
- Low Offset Voltage: 20 μV (Typical)
- CMRR: 108-dB (Typical) PSRR
- Quiescent Current: 35 μA (Maximum)
- Gain Bandwidth: 300 kHz
- Rail-to-Rail Input and Output
- Internal EMI and RFI Filtering

2 Applications

- Battery-Powered Instruments
- Temperature Measurements
- Transducer Applications
- Electronic Scales
- Medical Instrumentation
- Handheld Test Equipment
- Current Sense

3 Description

The OPA317 series of CMOS operational amplifiers offer precision performance at a very competitive price. These devices are members of the Zero-Drift family of amplifiers that use a proprietary autocalibration technique to simultaneously provide low offset voltage (90 μV maximum) and near-zero drift over time and temperature at only 35 μA (maximum) of quiescent current.

The OPA317 family features rail-to-rail input and output in addition to near flat 1/f noise, making this amplifier ideal for many applications, and much easier to design into a system. These devices are optimized for low-voltage operation as low as 1.8 V (± 0.9 V) and up to 5.5 V (± 2.75 V).

The OPA317 (single version) is available in the SC70-5, SOT23-5, and SOIC-8 packages. The OPA2317 (dual version) is offered in the VSSOP-8 and SOIC-8 packages. The OPA4317 is offered in the standard SOIC-14 and TSSOP-14 packages. All versions are specified for operation from -40°C to $+125^{\circ}\text{C}$.

Device Information⁽¹⁾

PART NUMBER	PACKAGE	BODY SIZE (NOM)
OPA317	SOIC (8)	3.91 mm x 4.90 mm
	SOT-23 (5)	1.60 mm x 2.90 mm
	SC70 (5)	1.25 mm x 2.00 mm
OPA2317	SOIC (8)	3.91 mm x 4.90 mm
	VSSOP (8)	3.00 mm x 3.00 mm
OPA4317	SOIC (14)	3.91 mm x 8.65 mm
	TSSOP (14)	4.40 mm x 5.00 mm

(1) For all available packages, see the orderable addendum at the end of the data sheet.

Distribution of Offset Voltage

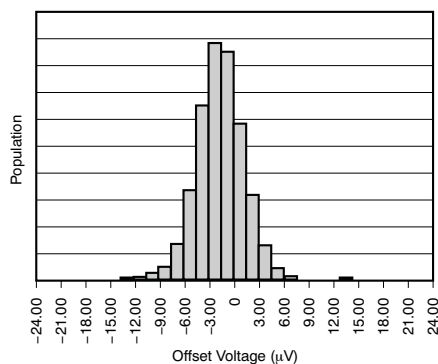

Table of Contents

1 Features 1 2 Applications 1 3 Description 1 4 Revision History 2 5 Pin Configuration and Functions 3 6 Specifications 5 6.1 Absolute Maximum Ratings 5 6.2 ESD Ratings..... 5 6.3 Recommended Operating Conditions 5 6.4 Thermal Information: OPA317 6 6.5 Thermal Information: OPA2317 6 6.6 Thermal Information: OPA4317 6 6.7 Electrical Characteristics: $V_S = 1.8\text{ V to }5.5\text{ V}$ 7 6.8 Typical Characteristics 8 7 Parameter Measurement Information 11 8 Detailed Description 12 8.1 Overview 12 8.2 Functional Block Diagram 12 8.3 Feature Description..... 12	8.4 Device Functional Modes 14 9 Application and Implementation 15 9.1 Application Information..... 15 9.2 Typical Applications 16 9.3 System Example 18 10 Power Supply Recommendations 18 11 Layout 19 11.1 Layout Guidelines 19 11.2 Layout Example 19 12 Device and Documentation Support 20 12.1 Documentation Support 20 12.2 Receiving Notification of Documentation Updates 20 12.3 Related Links 20 12.4 Community Resources..... 20 12.5 Trademarks 20 12.6 Electrostatic Discharge Caution..... 20 12.7 Glossary 20 13 Mechanical, Packaging, and Orderable Information 21
--	---

4 Revision History

NOTE: Page numbers for previous revisions may differ from page numbers in the current version.

Changes from Revision A (June 2013) to Revision B	Page
• Added <i>ESD Ratings</i> table, <i>Feature Description</i> section, <i>Device Functional Modes</i> , <i>Application and Implementation</i> section, <i>Power Supply Recommendations</i> section, <i>Layout</i> section, <i>Device and Documentation Support</i> section, and <i>Mechanical, Packaging, and Orderable Information</i> section.	1
• Deleted <i>Ordering Information</i> table; see POA at the end of the data sheet.....	1

Changes from Original (May 2013) to Revision A	Page
• Deleted PSRR <i>Features</i> bullet	1
• Changed Quiescent Current <i>Features</i> bullet.....	1
• Changed second sentence in <i>Description</i> section	1
• Changed PSRR maximum value.....	7

5 Pin Configuration and Functions

**OPA317: DBV Package
5-Pin SOT-23
Top View**

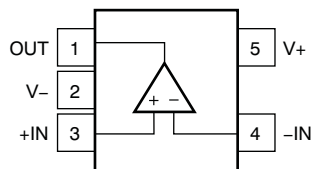

**OPA317: DCK Package
5-Pin SC70
Top View**

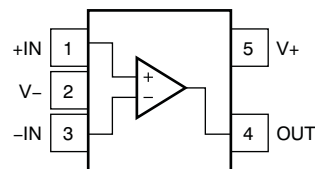

Pin Functions (5-Pin Packages)

NAME	PIN		I/O	DESCRIPTION
	SOT-23	SC70		
+IN	3	1	I	Noninverting input
-IN	4	3	I	Inverting input
OUT	1	4	O	Output
V+	5	5	—	Positive (highest) power supply
V-	2	2	—	Negative (lowest) power supply

**OPA317: D Package
8-Pin SOIC
Top View**

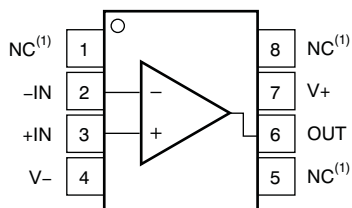

**OPA2317: D and DGK Packages
8-Pin SOIC and VSSOP
Top View**

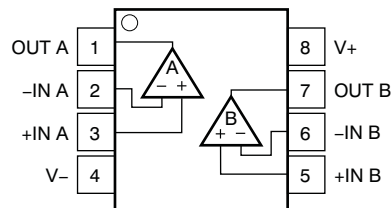

(1) NC - No internal connection

Pin Functions (8-Pin Packages)

NAME	PIN		I/O	DESCRIPTION
	OPA317 SOIC	OPA2317 SOIC and VSSOP		
+IN	3	—	I	Noninverting input
-IN	2	—	I	Inverting input
+IN A	—	3	I	Noninverting input, channel A
-IN A	—	2	I	Inverting input, channel A
+IN B	—	5	I	Noninverting input, channel B
-IN B	—	6	I	Inverting input, channel B
NC	1	—	—	No internal connection
	5			
	8			
OUT	6	—	O	Output
OUT A	—	1	O	Output, channel A
OUT B	—	7	O	Output, channel B
V+	7	8	—	Positive (highest) power supply
V-	4	4	—	Negative (lowest) power supply

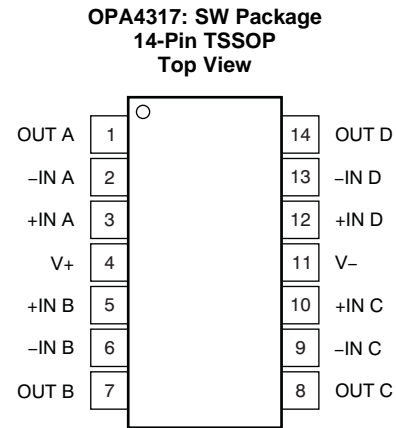
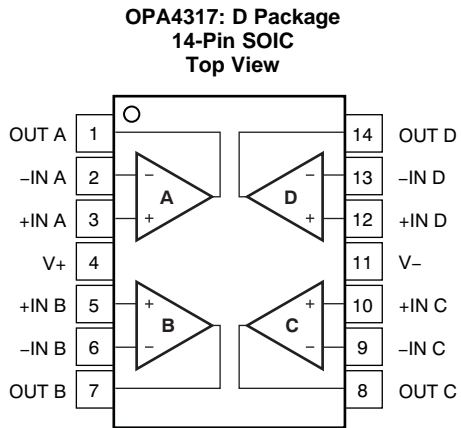

Pin Functions (14-Pin Packages)

PIN		I/O	DESCRIPTION
NAME	SOIC, TSSOP		
+IN A	3	I	Noninverting input, channel A
-IN A	2	I	Inverting input, channel A
+IN B	5	I	Noninverting input, channel B
-IN B	6	I	Inverting input, channel B
+IN C	10	I	Noninverting input, channel C
-IN C	9	I	Inverting input, channel C
+IN D	12	I	Noninverting input, channel D
-IN D	13	I	Inverting input, channel D
OUT A	1	O	Output, channel A
OUT B	7	O	Output, channel B
OUT C	8	O	Output, channel C
OUT D	14	O	Output, channel D
V+	4	—	Positive (highest) power supply
V-	11	—	Negative (lowest) power supply

6 Specifications

6.1 Absolute Maximum Ratings

Over operating free-air temperature range, unless otherwise noted.⁽¹⁾

		MIN	MAX	UNIT
$V_S = (V+) - (V-)$	Supply voltage		7	V
	Signal input terminals ⁽²⁾	$(V-) - 0.3$	$(V+) + 0.3$	V
	Signal input terminals ⁽²⁾	-10	10	mA
	Output short circuit ⁽³⁾	Continuous		
T_A	Operating temperature	-40	150	°C
T_J	Junction temperature		150	°C
T_{stg}	Storage temperature	-65	150	°C

- (1) Stresses beyond those listed under *Absolute Maximum Ratings* may cause permanent damage to the device. These are stress ratings only, which do not imply functional operation of the device at these or any other conditions beyond those indicated under *Recommended Operating Conditions*. Exposure to absolute-maximum-rated conditions for extended periods may affect device reliability.
- (2) Input terminals are diode-clamped to the power-supply rails. Input signals that can swing more than 0.3 V beyond the supply rails must be current-limited to 10 mA or less.
- (3) Short-circuit to ground, one amplifier per package.

6.2 ESD Ratings

		VALUE	UNIT
$V_{(ESD)}$	Electrostatic discharge	Human-body model (HBM), per ANSI/ESDA/JEDEC JS-001 ⁽¹⁾	±4000
		Charged-device model (CDM), per JEDEC specification JESD22-C101 ⁽²⁾	±1000
		Machine model (MM)	±400

- (1) JEDEC document JEP155 states that 500-V HBM allows safe manufacturing with a standard ESD control process.
- (2) JEDEC document JEP157 states that 250-V CDM allows safe manufacturing with a standard ESD control process.

6.3 Recommended Operating Conditions

over operating free-air temperature range (unless otherwise noted).

		MIN	MAX	UNIT
$(V+ - V-)$	Supply voltage	1.8 (±0.9)	5.5 (±2.25)	V
T_A	Specified temperature	-40	125	°C

6.4 Thermal Information: OPA317

THERMAL METRIC ⁽¹⁾	OPA317			UNIT
	D (SOIC)	DBV (SOT-23)	DCK (SC70)	
	8 PINS	5 PINS	5 PINS	
R _{θJA} Junction-to-ambient thermal resistance	140.1	220.8	298.4	°C/W
R _{θJC(top)} Junction-to-case (top) thermal resistance	89.8	97.5	65.4	°C/W
R _{θJB} Junction-to-board thermal resistance	80.6	61.7	97.1	°C/W
ψ _{JT} Junction-to-top characterization parameter	28.7	7.6	0.8	°C/W
ψ _{JB} Junction-to-board characterization parameter	80.1	61.1	95.5	°C/W
R _{θJC(bot)} Junction-to-case (bottom) thermal resistance	—	—	—	°C/W

(1) For more information about traditional and new thermal metrics, see the [Semiconductor and IC Package Thermal Metrics](#) application report.

6.5 Thermal Information: OPA2317

THERMAL METRIC ⁽¹⁾	OPA2317		UNIT
	D (SOIC)	DGK (VSSOP)	
	8 PINS	8 PINS	
R _{θJA} Junction-to-ambient thermal resistance	124	180.3	°C/W
R _{θJC(top)} Junction-to-case (top) thermal resistance	73.7	48.1	°C/W
R _{θJB} Junction-to-board thermal resistance	64.4	100.9	°C/W
ψ _{JT} Junction-to-top characterization parameter	18	2.4	°C/W
ψ _{JB} Junction-to-board characterization parameter	63.9	99.3	°C/W
R _{θJC(bot)} Junction-to-case (bottom) thermal resistance	—	—	°C/W

(1) For more information about traditional and new thermal metrics, see the [Semiconductor and IC Package Thermal Metrics](#) application report.

6.6 Thermal Information: OPA4317

THERMAL METRIC ⁽¹⁾	OPA4317		UNIT
	D (SOIC)	PW (TSSOP)	
	14 PINS	14 PINS	
R _{θJA} Junction-to-ambient thermal resistance	83.8	120.8	°C/W
R _{θJC(top)} Junction-to-case (top) thermal resistance	70.7	34.3	°C/W
R _{θJB} Junction-to-board thermal resistance	59.5	62.8	°C/W
ψ _{JT} Junction-to-top characterization parameter	11.6	1	°C/W
ψ _{JB} Junction-to-board characterization parameter	37.7	56.5	°C/W
R _{θJC(bot)} Junction-to-case (bottom) thermal resistance	—	—	°C/W

(1) For more information about traditional and new thermal metrics, see the [Semiconductor and IC Package Thermal Metrics](#) application report.

6.7 Electrical Characteristics: $V_S = 1.8\text{ V to }5.5\text{ V}$

At $T_A = 25^\circ\text{C}$, $R_L = 10\text{ k}\Omega$ connected to midsupply, $V_{CM} = V_{OUT} = \text{midsupply}$, unless otherwise noted.

PARAMETER		TEST CONDITIONS	MIN	TYP	MAX	UNIT
OFFSET VOLTAGE						
V_{OS}	Input offset voltage	$V_S = 5\text{ V}$		20	± 90	μV
		$T_A = -40^\circ\text{C to }+125^\circ\text{C}$, $V_S = 5\text{ V}$			± 100	
dV_{OS}/dT	Input offset voltage vs temperature	$T_A = -40^\circ\text{C to }+125^\circ\text{C}$		0.05		$\mu\text{V}/^\circ\text{C}$
PSRR	Input offset voltage vs power supply	$T_A = -40^\circ\text{C to }+125^\circ\text{C}$, $V_S = 1.8\text{ V to }5.5\text{ V}$		1	10	$\mu\text{V}/\text{V}$
	Long-term stability ⁽¹⁾			See ⁽¹⁾		
	Channel separation, DC			5		$\mu\text{V}/\text{V}$
INPUT BIAS CURRENT						
I_B	Input bias current			± 275		pA
		OPA4317		± 155		
		$T_A = -40^\circ\text{C to }+125^\circ\text{C}$		± 300		
I_{OS}	Input offset current			± 400		pA
		OPA4317		± 140		
NOISE						
e_n	Input voltage noise density	$f = 1\text{ kHz}$		55		$\text{nV}/\sqrt{\text{Hz}}$
	Input voltage noise	$f = 0.01\text{ Hz to }1\text{ Hz}$		0.3		μV_{PP}
		$f = 0.1\text{ Hz to }10\text{ Hz}$		1.1		
i_n	Input current noise	$f = 10\text{ Hz}$		100		$\text{fA}/\sqrt{\text{Hz}}$
INPUT VOLTAGE RANGE						
V_{CM}	Common-mode voltage		$(V-) - 0.1$		$(V+) + 0.1$	V
CMRR	Common-mode rejection ratio	$T_A = -40^\circ\text{C to }+125^\circ\text{C}$ $(V-) - 0.1\text{ V} < V_{CM} < (V+) + 0.1\text{ V}$	95	108		dB
		OPA4317 $T_A = -40^\circ\text{C to }+125^\circ\text{C}$ $(V-) - 0.1\text{ V} < V_{CM} < (V+) + 0.1\text{ V}$, $V_S = 5.5\text{ V}$	95	108		
INPUT CAPACITANCE						
	Differential			2		pF
	Common-mode			4		pF
OPEN-LOOP GAIN						
A_{OL}	Open-loop voltage gain	$T_A = -40^\circ\text{C to }+125^\circ\text{C}$, $R_L = 10\text{ k}\Omega$ $(V-) + 100\text{ mV} < V_O < (V+) - 100\text{ mV}$	100	110		dB
FREQUENCY RESPONSE						
GBW	Gain-bandwidth product	$C_L = 100\text{ pF}$		300		kHz
SR	Slew rate	$G = 1$		0.15		$\text{V}/\mu\text{s}$
OUTPUT						
	Voltage output swing from rail	$T_A = -40^\circ\text{C to }+125^\circ\text{C}$		30	100	mV
I_{SC}	Short-circuit current			± 5		mA
C_L	Capacitive load drive			See the Typical Characteristics section		
	Open-loop output impedance	$f = 350\text{ kHz}$, $I_O = 0$		2		$\text{k}\Omega$
POWER SUPPLY						
V_S	Specified voltage		1.8		5.5	V
I_Q	Quiescent current per amplifier	$T_A = -40^\circ\text{C to }+125^\circ\text{C}$, $I_O = 0$		21	35	μA
	Turnon time	$V_S = 5\text{ V}$		100		μs

(1) 300-hour life test at 150°C demonstrated randomly distributed variation of approximately $1\ \mu\text{V}$.

6.8 Typical Characteristics

At $T_A = 25^\circ\text{C}$, $C_L = 0\text{ pF}$, $R_L = 10\text{ k}\Omega$ connected to midsupply, $V_{CM} = V_{OUT} = \text{midsupply}$, unless otherwise noted.

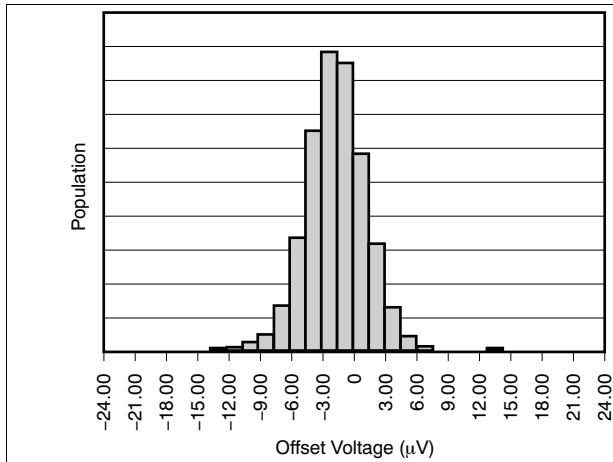

Figure 1. Offset Voltage Production Distribution

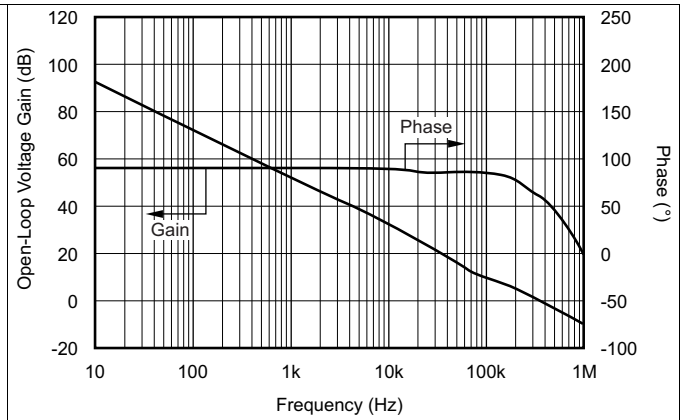

Figure 2. Open-Loop Gain vs Frequency

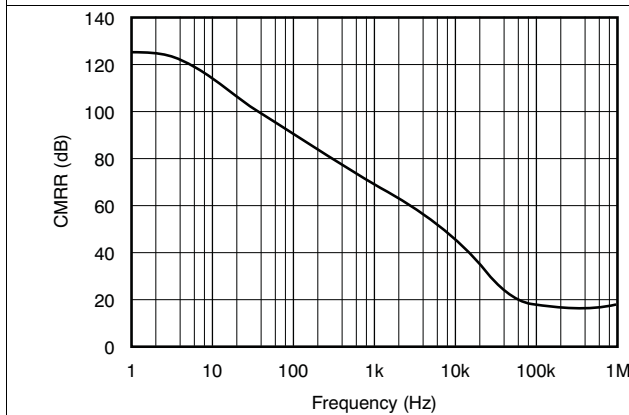

Figure 3. Common-Mode Rejection Ratio vs Frequency

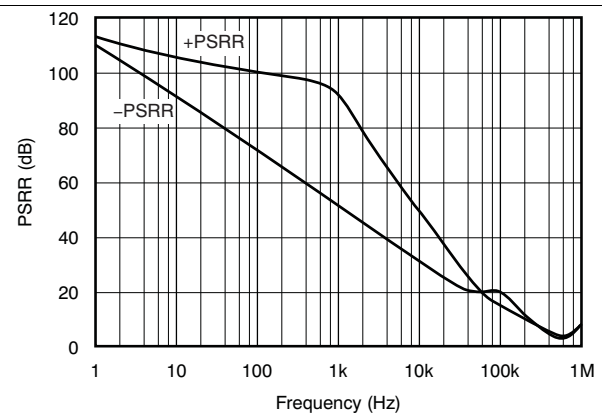

Figure 4. Power-Supply Rejection Ratio vs Frequency

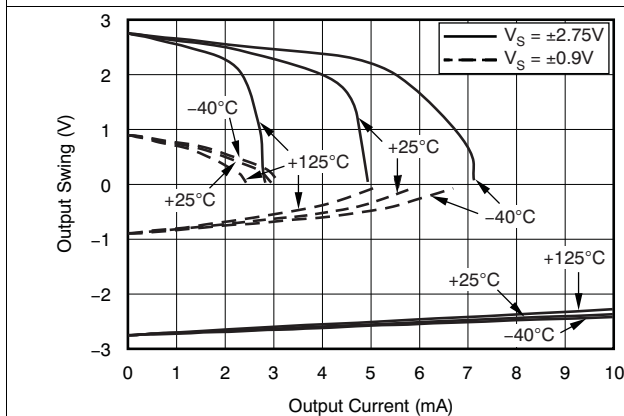

Figure 5. Output Voltage Swing vs Output Current

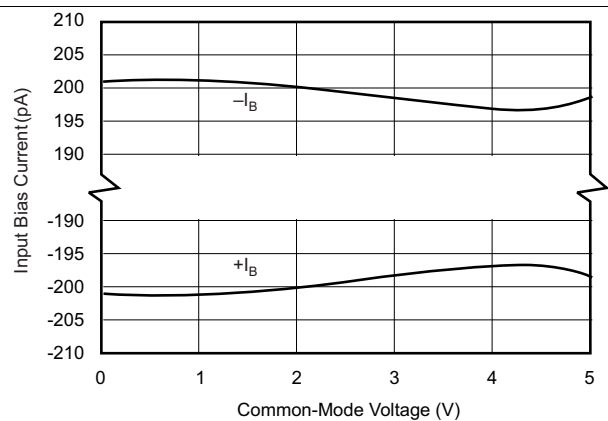

Figure 6. Input Bias Current vs Common-Mode Voltage

Typical Characteristics (continued)

At $T_A = 25^\circ\text{C}$, $C_L = 0\text{ pF}$, $R_L = 10\text{ k}\Omega$ connected to midsupply, $V_{CM} = V_{OUT} = \text{midsupply}$, unless otherwise noted.

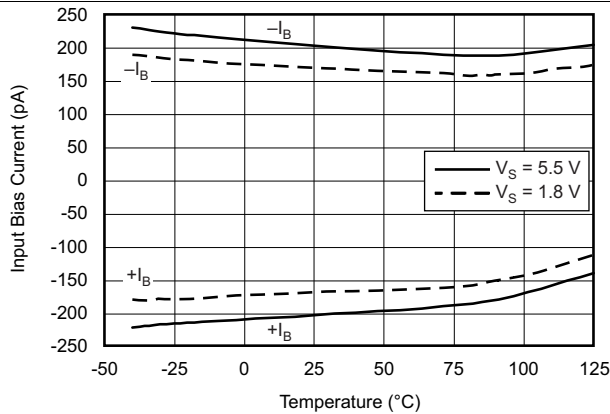

Figure 7. Input Bias Current vs Temperature

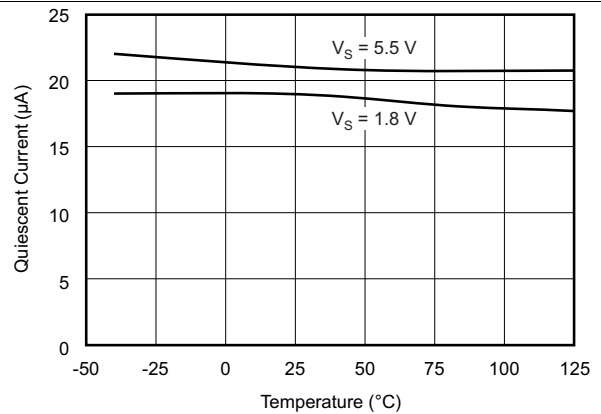

Figure 8. Quiescent Current vs Temperature

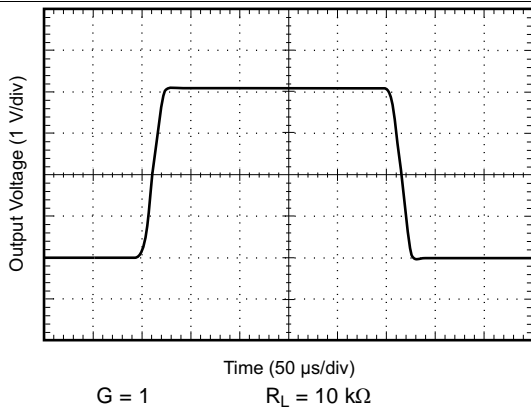

Figure 9. Large-Signal Step Response

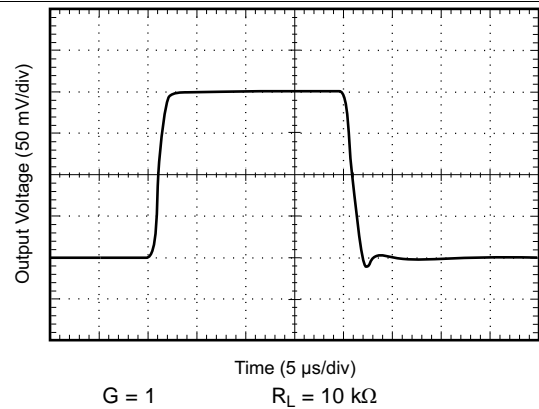

Figure 10. Small-Signal Step Response

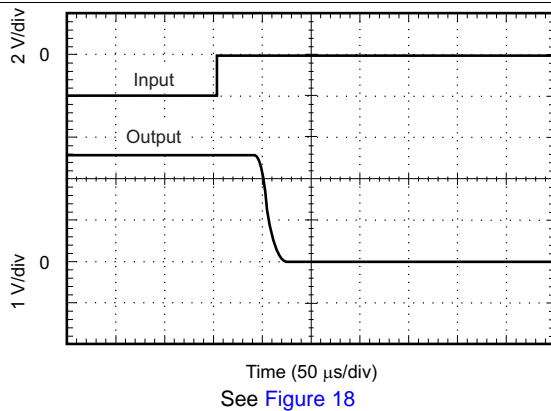

Figure 11. Positive Overvoltage Recovery

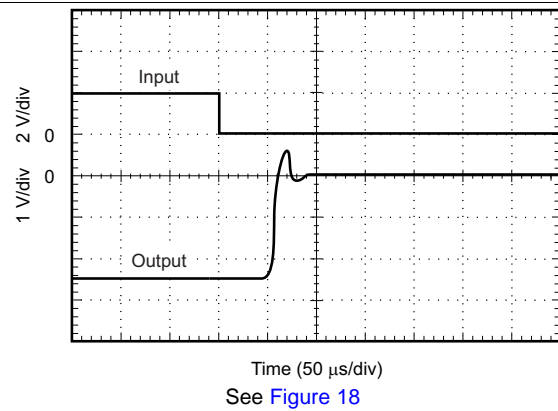

Figure 12. Negative Overvoltage Recovery

Typical Characteristics (continued)

At $T_A = 25^\circ\text{C}$, $C_L = 0\text{ pF}$, $R_L = 10\text{ k}\Omega$ connected to midsupply, $V_{CM} = V_{OUT} = \text{midsupply}$, unless otherwise noted.

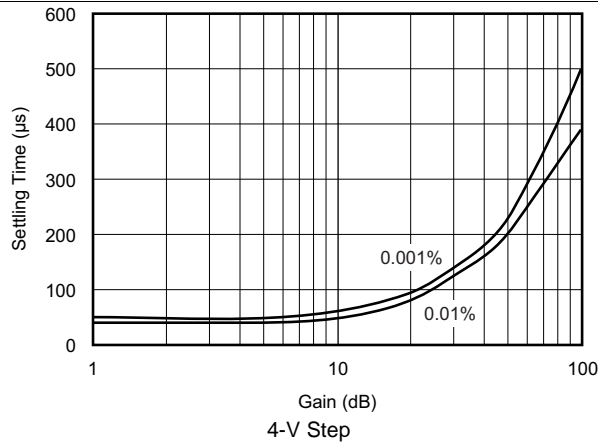

Figure 13. Settling Time vs Closed-Loop Gain

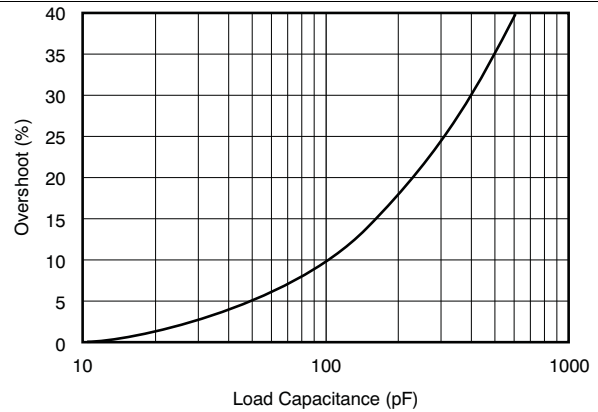

Figure 14. Small-Signal Overshoot vs Load Capacitance

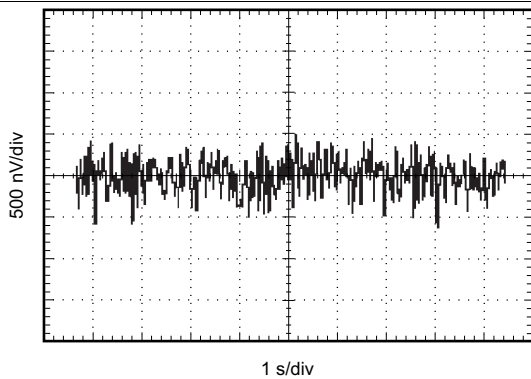

Figure 15. 0.1-Hz to 10-Hz Noise

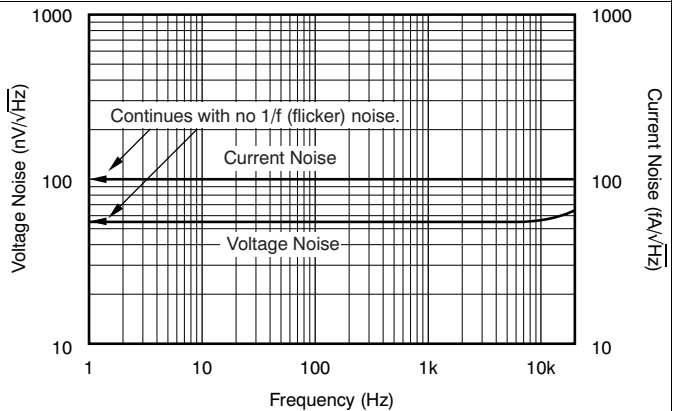
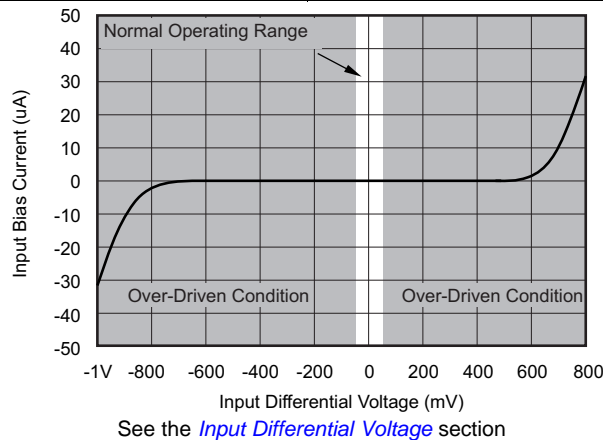

Figure 16. Current and Voltage Noise Spectral Density vs Frequency



See the [Input Differential Voltage](#) section

Figure 17. Input Bias Current vs Input Differential Voltage

7 Parameter Measurement Information

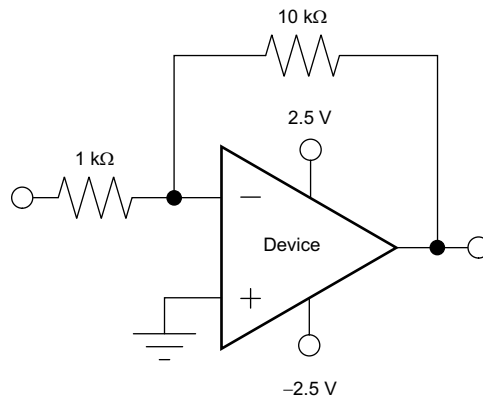

Figure 18. Overvoltage Recovery Circuit

8 Detailed Description

8.1 Overview

The OPAx317 series is a family of low-power, rail-to-rail input and output operational amplifiers. These devices operate from 1.8 V to 5.5 V, are unity-gain stable, and are suitable for a wide range of general-purpose applications. The class AB output stage is capable of driving $\leq 10\text{-k}\Omega$ loads connected to any point between $V+$ and ground. The input common-mode voltage range includes both rails and allows the OPA317 series to be used in virtually any single-supply application. Rail-to-rail input and output swing significantly increases dynamic range, especially in low-supply applications, and makes them ideal for driving sampling analog-to-digital converters (ADCs).

8.2 Functional Block Diagram

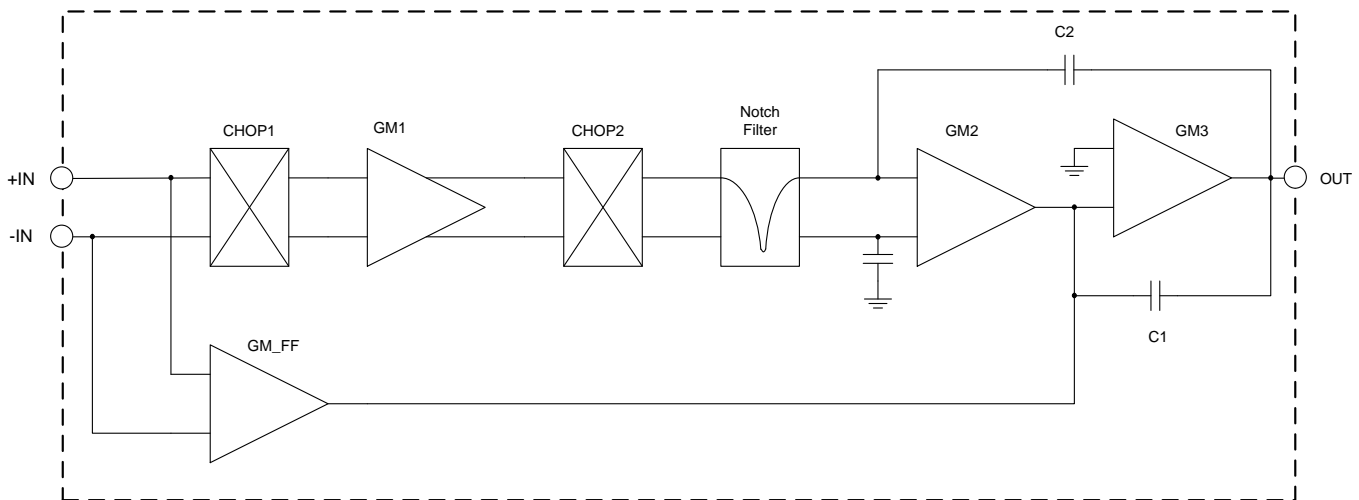

Copyright © 2016, Texas Instruments Incorporated

8.3 Feature Description

8.3.1 Operating Voltage

The OPA317 series of operational amplifiers can be used with single or dual supplies from an operating range of $V_S = 1.8\text{ V} (\pm 0.9\text{ V})$ up to $5.5\text{ V} (\pm 2.75\text{ V})$.

CAUTION

Supply voltages greater than 7 V can permanently damage the device.

See the [Absolute Maximum Ratings](#) table. Key parameters that vary over the supply voltage or temperature range are shown in the [Typical Characteristics](#) section.

Feature Description (continued)

8.3.2 Input Voltage

The OPA317, OPA2317, and OPA4317 input common-mode voltage range extends 0.1 V beyond the supply rails. The OPA317 device is designed to cover the full range without the troublesome transition region found in some other rail-to-rail amplifiers.

Typically, input bias current is about 200 pA; however, input voltages exceeding the power supplies can cause excessive current to flow into or out of the input pins. Momentary voltages greater than the power supply can be tolerated if the input current is limited to 10 mA. This limitation is easily accomplished with an input resistor, as shown in Figure 19.

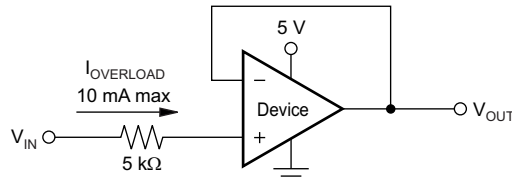

NOTE: Current limiting resistor required if input voltage exceeds supply rails by ≥ 0.3 V.

Figure 19. Input Current Protection

8.3.3 Input Differential Voltage

The typical input bias current of the OPA317 during normal operation is approximately 200 pA. In overdriven conditions, the bias current can increase significantly (see Figure 17). The most common cause of an overdriven condition occurs when the operational amplifier is outside of the linear range of operation. When the output of the operational amplifier is driven to one of the supply rails, the feedback loop requirements cannot be satisfied, and a differential input voltage develops across the input pins. This differential input voltage results in activation of parasitic diodes inside the front-end input chopping switches that combine with 10-kΩ electromagnetic interference (EMI) filter resistors to create the equivalent circuit shown in Figure 20.

NOTE

The input bias current remains within specification within the linear region.

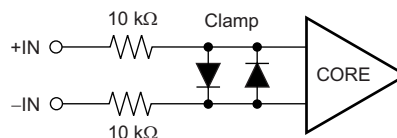

Figure 20. Equivalent Input Circuit

8.3.4 Internal Offset Correction

The OPA317, OPA2317, and OPA4317 operational amplifiers use an auto-calibration technique with a time-continuous, 125-kHz operational amplifier in the signal path. This amplifier is zero-corrected every 8 μ s using a proprietary technique. Upon power up, the amplifier requires approximately 100 μ s to achieve specified V_{OS} accuracy. This design has no aliasing or flicker noise.

8.3.5 EMI Susceptibility and Input Filtering

Operational amplifiers vary in susceptibility to EMI. If conducted EMI enters the operational amplifier, the DC offset observed at the amplifier output may shift from its nominal value while the EMI is present. This shift is a result of signal rectification associated with the internal semiconductor junctions. While all operational amplifier pin functions can be affected by EMI, the input pins are likely to be the most susceptible. The OPA317 operational amplifier family incorporates an internal input low-pass filter that reduces the amplifier response to EMI. Both common-mode and differential mode filtering are provided by the input filter. The filter is designed for a cutoff frequency of approximately 8 MHz (-3 dB), with a roll-off of 20 dB per decade.

8.4 Device Functional Modes

The OPAx317 family of devices are powered on when the supply is connected. The device can be operated as a single-supply operational amplifier or a dual-supply amplifier, depending on the application.

9 Application and Implementation

NOTE

Information in the following applications sections is not part of the TI component specification, and TI does not warrant its accuracy or completeness. TI's customers are responsible for determining suitability of components for their purposes. Customers should validate and test their design implementation to confirm system functionality.

9.1 Application Information

The OPA317, OPA2317, and OPA4317 are unity-gain stable, precision operational amplifiers free from unexpected output and phase reversal. Proprietary Zero-Drift circuitry gives the benefit of low input offset voltage over time and temperature, as well as lowering the $1/f$ noise component. As a result of the high PSRR, these devices work well in applications that run directly from battery power without regulation. The OPA317 family is optimized for low-voltage, single-supply operation. These miniature, high-precision, low quiescent current amplifiers offer high impedance inputs that have a common-mode range 100 mV beyond the supplies, and a rail-to-rail output that swings within 100 mV of the supplies under normal test conditions. The OPA317 series are precision amplifiers for cost-sensitive applications.

9.1.1 Achieving Output Swing to the Op Amp Negative Rail

Some applications require output voltage swings from 0 V to a positive full-scale voltage (such as 2.5 V) with excellent accuracy. With most single-supply operational amplifiers, problems arise when the output signal approaches 0 V, near the lower output swing limit of a single-supply operational amplifier. A good single-supply operational amplifier may swing close to single-supply ground, but does not reach ground. The output of the OPA317, OPA2317, and OPA4317 can be made to swing to ground, or slightly below, on a single-supply power source. To do so requires the use of another resistor and an additional, more negative power supply than the operational amplifier negative supply. A pulldown resistor can be connected between the output and the additional negative supply to pull the output down below the value that the output would otherwise achieve, as shown in [Figure 21](#).

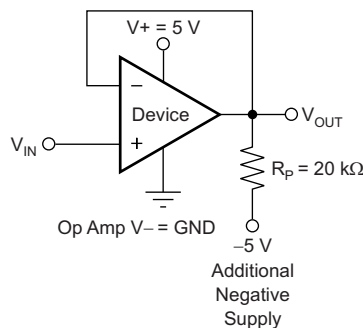
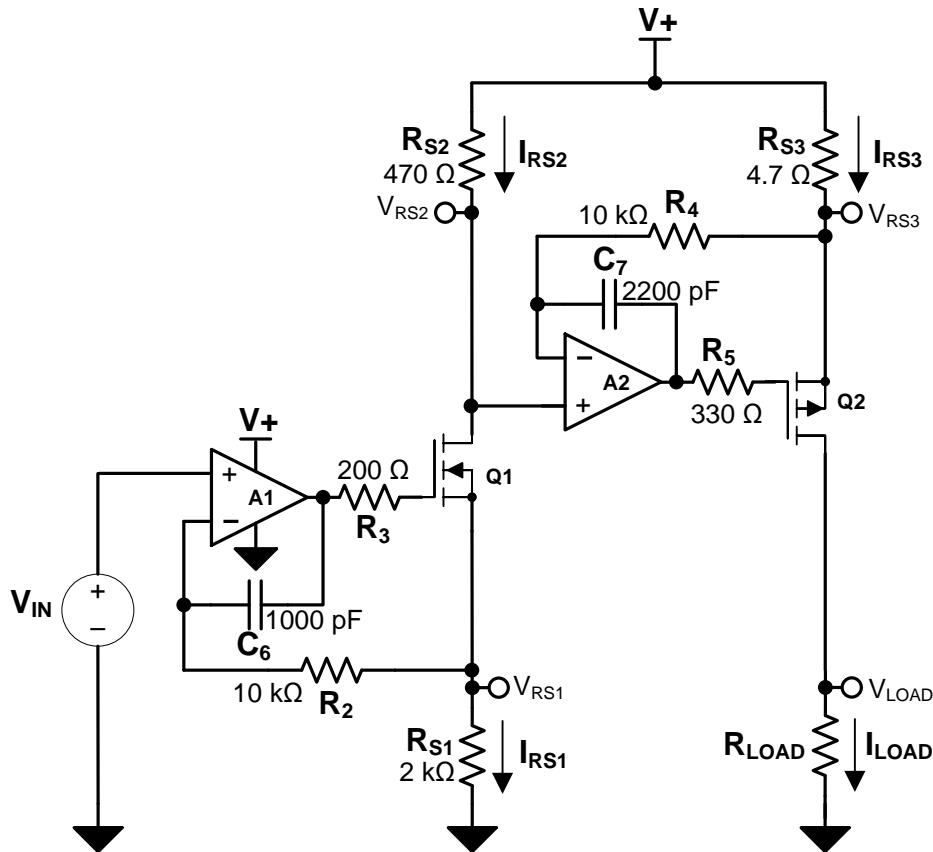

Figure 21. For V_{OUT} Range to Ground

The OPA317, OPA2317, and OPA4317 have an output stage that allows the output voltage to be pulled to its negative supply rail, or slightly below, using the technique previously described. This technique only works with some types of output stages. The OPA317, OPA2317, and OPA4317 have been characterized to perform with this technique; the recommended resistor value is approximately 20 k Ω . This configuration increases the current consumption by several hundreds of microamps. Accuracy is excellent down to 0 V and as low as -2 mV. Limiting and nonlinearity occur below -2 mV, but excellent accuracy returns as the output drives back up above -2 mV. Lowering the resistance of the pulldown resistor allows the operational amplifier to swing even further below the negative rail. Use resistances as low as 10 k Ω to achieve excellent accuracy down to -10 mV.

9.2 Typical Applications

The circuit shown in Figure 22 is a high-side voltage-to-current (V-I) converter. It translates an input voltage of 0 V to 2 V to an output current of 0 mA to 100 mA. Figure 23 shows the measured transfer function for this circuit. The low offset voltage and offset drift of the OPA317 facilitate excellent DC accuracy for the circuit.



Copyright © 2016, Texas Instruments Incorporated

Figure 22. High-Side Voltage-to-Current (V-I) Converter

9.2.1 Design Requirements

The design requirements are as follows:

- Supply Voltage: 5-V DC
- Input: 0-V to 2-V DC
- Output: 0-mA to 100-mA DC

9.2.2 Detailed Design Procedure

The V-I transfer function of the circuit is based on the relationship between the input voltage, V_{IN} , and the three current-sensing resistors: R_{S1} , R_{S2} , and R_{S3} . The relationship between V_{IN} and R_{S1} determines the current that flows through the first stage of the design. The current gain from the first stage to the second stage is based on the relationship between R_{S2} and R_{S3} .

Typical Applications (continued)

For a successful design, pay close attention to the DC characteristics of the operational amplifier chosen for the application. To meet the performance goals, this application benefits from an operational amplifier with low offset voltage, low temperature drift, and rail-to-rail output. The OPA2317 CMOS operational amplifier is a high-precision, 5- μ V offset, 0.05- μ V/ $^{\circ}$ C drift amplifier optimized for low-voltage, single-supply operation with an output swing to within 50 mV of the positive rail. The OPA2317 family uses chopping techniques to provide low initial offset voltage and near-zero drift over time and temperature. Low offset voltage and low drift reduce the offset error in the system, making these devices appropriate for precise DC control. The rail-to-rail output stage of the OPA2317 ensures that the output swing of the operational amplifier is able to fully control the gate of the MOSFET devices within the supply rails.

9.2.3 Application Curve

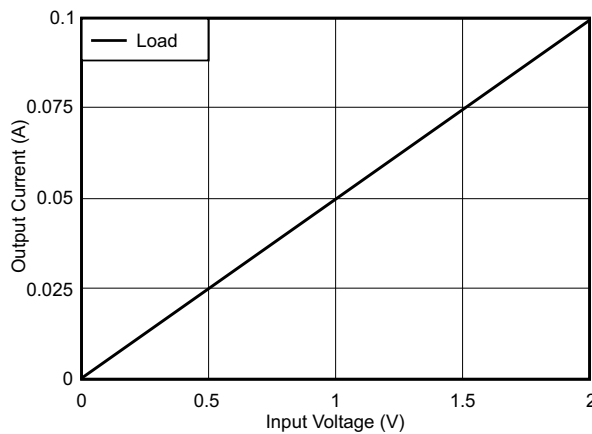
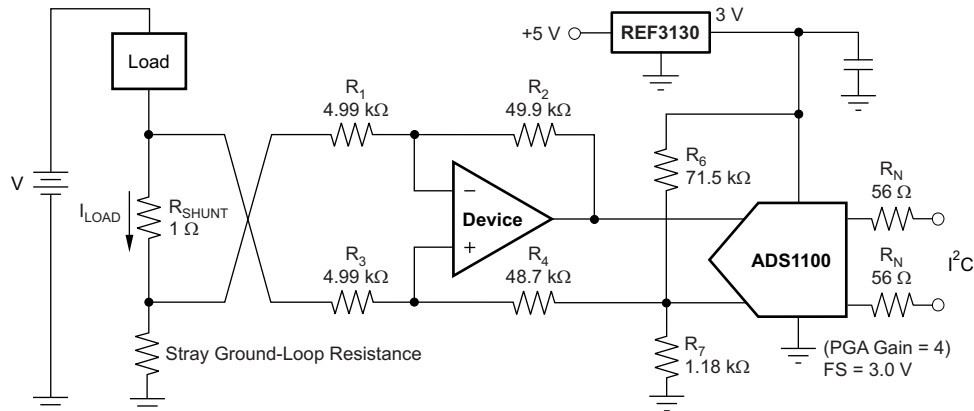

Figure 23. Measured Transfer Function for High-Side V-I Converter

9.3 System Example

R_N are operational resistors used to isolate the [ADS1100](#) from the noise of the digital I²C bus. The ADS1100 device is a 16-bit converter; therefore, a precise reference is essential for maximum accuracy. If absolute accuracy is not required and the 5-V power supply is sufficiently stable, the [REF3130](#) device may be omitted.



Copyright © 2016, Texas Instruments Incorporated

NOTE: 1% resistors provide adequate common-mode rejection at small ground-loop errors.

Figure 24. Low-Side Current Monitor

10 Power Supply Recommendations

The OPAx317 device is specified for operation from 1.8 V to 5.5 V (± 0.9 V to ± 2.75 V); many specifications apply from -40°C to $+125^\circ\text{C}$. The [Electrical Characteristics: \$V_S = 1.8\$ V to 5.5 V](#) table presents parameters that can exhibit significant variance with regard to operating voltage or temperature.

CAUTION

Supply voltages larger than 7 V can permanently damage the device (see the [Absolute Maximum Ratings](#) table).

Place 0.1- μF bypass capacitors close to the power-supply pins to reduce errors coupling in from noisy or high-impedance power supplies. For more detailed information on bypass capacitor placement, see the [Layout Guidelines](#) section.

11 Layout

11.1 Layout Guidelines

Attention to good layout practice is always recommended. Keep traces short and, when possible, use a printed-circuit board (PCB) ground plane with surface-mount components placed as close to the device pins as possible. Place a 0.1- μ F capacitor closely across the supply pins. Apply these guidelines throughout the analog circuit to improve performance and provide benefits, such as reducing the electromagnetic interference (EMI) susceptibility.

Optimize circuit layout and mechanical conditions for lowest offset voltage and precision performance. Avoid temperature gradients that create thermoelectric (Seebeck) effects in the thermocouple junctions formed from connecting dissimilar conductors. These thermally-generated potentials can be made to cancel by assuring they are equal on both input terminals. Other layout and design considerations include:

- Use low thermoelectric-coefficient conditions (avoid dissimilar metals).
- Thermally isolate components from power supplies or other heat sources.
- Shield operational amplifier and input circuitry from air currents, such as cooling fans.

Following these guidelines reduces the likelihood of junctions being at different temperatures, which can cause thermoelectric voltage drift of 0.1 μ V/ $^{\circ}$ C or higher, depending on the materials used.

11.2 Layout Example

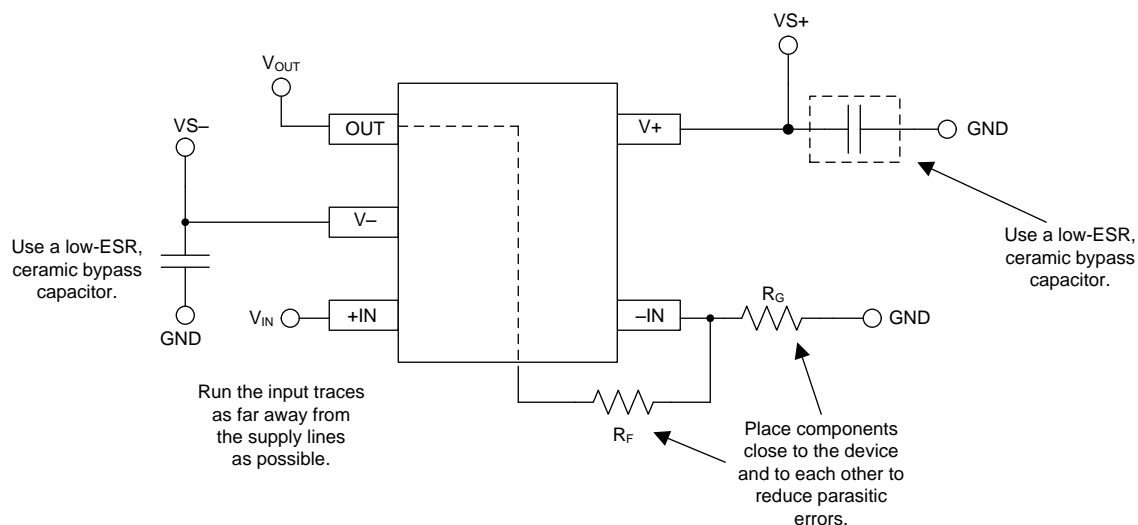

Copyright © 2016, Texas Instruments Incorporated

Figure 25. OPAx317 Layout Example

12 Device and Documentation Support

12.1 Documentation Support

12.1.1 Related Documentation

For related documentation see the following:

- *Self-Calibrating, 16-Bit Analog-to-Digital Converter,*
- *15ppm/°C Max, 100µA, SOT23-3 Series Voltage Reference,*

12.2 Receiving Notification of Documentation Updates

To receive notification of documentation updates, navigate to the device product folder on ti.com. In the upper right corner, click on *Alert me* to register and receive a weekly digest of any product information that has changed. For change details, review the revision history included in any revised document.

12.3 Related Links

Table 1 lists quick access links. Categories include technical documents, support and community resources, tools and software, and quick access to sample or buy.

Table 1. Related Links

PARTS	PRODUCT FOLDER	SAMPLE & BUY	TECHNICAL DOCUMENTS	TOOLS & SOFTWARE	SUPPORT & COMMUNITY
OPA317	Click here	Click here	Click here	Click here	Click here
OPA2317	Click here	Click here	Click here	Click here	Click here
OPA4317	Click here	Click here	Click here	Click here	Click here

12.4 Community Resources

The following links connect to TI community resources. Linked contents are provided "AS IS" by the respective contributors. They do not constitute TI specifications and do not necessarily reflect TI's views; see TI's [Terms of Use](#).

TI E2E™ Online Community *TI's Engineer-to-Engineer (E2E) Community*. Created to foster collaboration among engineers. At e2e.ti.com, you can ask questions, share knowledge, explore ideas and help solve problems with fellow engineers.

Design Support *TI's Design Support* Quickly find helpful E2E forums along with design support tools and contact information for technical support.

12.5 Trademarks

E2E is a trademark of Texas Instruments.
All other trademarks are the property of their respective owners.

12.6 Electrostatic Discharge Caution



This integrated circuit can be damaged by ESD. Texas Instruments recommends that all integrated circuits be handled with appropriate precautions. Failure to observe proper handling and installation procedures can cause damage.

ESD damage can range from subtle performance degradation to complete device failure. Precision integrated circuits may be more susceptible to damage because very small parametric changes could cause the device not to meet its published specifications.

12.7 Glossary

SLYZ022 — *TI Glossary*.

This glossary lists and explains terms, acronyms, and definitions.

13 Mechanical, Packaging, and Orderable Information

The following pages include mechanical, packaging, and orderable information. This information is the most current data available for the designated devices. This data is subject to change without notice and revision of this document. For browser-based versions of this data sheet, refer to the left-hand navigation.

PACKAGING INFORMATION

Orderable Device	Status (1)	Package Type	Package Drawing	Pins	Package Qty	Eco Plan (2)	Lead/Ball Finish (6)	MSL Peak Temp (3)	Op Temp (°C)	Device Marking (4/5)	Samples
OPA2317ID	ACTIVE	SOIC	D	8	75	Green (RoHS & no Sb/Br)	CU NIPDAU	Level-1-260C-UNLIM	-40 to 125	O2317A	Samples
OPA2317IDGKR	ACTIVE	VSSOP	DGK	8	2500	Green (RoHS & no Sb/Br)	CU NIPDAUAG	Level-1-260C-UNLIM	-40 to 125	OVBQ	Samples
OPA2317IDGKT	ACTIVE	VSSOP	DGK	8	250	Green (RoHS & no Sb/Br)	CU NIPDAUAG	Level-1-260C-UNLIM	-40 to 125	OVBQ	Samples
OPA2317IDR	ACTIVE	SOIC	D	8	2500	Green (RoHS & no Sb/Br)	CU NIPDAU	Level-1-260C-UNLIM	-40 to 125	O2317A	Samples
OPA317ID	ACTIVE	SOIC	D	8	75	Green (RoHS & no Sb/Br)	CU NIPDAU	Level-1-260C-UNLIM	-40 to 125	O317A	Samples
OPA317IDBVR	ACTIVE	SOT-23	DBV	5	3000	Green (RoHS & no Sb/Br)	CU NIPDAU	Level-1-260C-UNLIM	-40 to 125	OVCQ	Samples
OPA317IDBVT	ACTIVE	SOT-23	DBV	5	250	Green (RoHS & no Sb/Br)	CU NIPDAU	Level-1-260C-UNLIM	-40 to 125	OVCQ	Samples
OPA317IDCKR	ACTIVE	SC70	DCK	5	3000	Green (RoHS & no Sb/Br)	CU NIPDAU	Level-1-260C-UNLIM	-40 to 125	SJP	Samples
OPA317IDCKT	ACTIVE	SC70	DCK	5	250	Green (RoHS & no Sb/Br)	CU NIPDAU	Level-1-260C-UNLIM	-40 to 125	SJP	Samples
OPA317IDR	ACTIVE	SOIC	D	8	2500	Green (RoHS & no Sb/Br)	CU NIPDAU	Level-1-260C-UNLIM	-40 to 125	O317A	Samples
OPA4317ID	ACTIVE	SOIC	D	14	50	Green (RoHS & no Sb/Br)	CU NIPDAU	Level-1-260C-UNLIM	-40 to 125	O4317A	Samples
OPA4317IDR	ACTIVE	SOIC	D	14	2500	Green (RoHS & no Sb/Br)	CU NIPDAU	Level-1-260C-UNLIM	-40 to 125	O4317A	Samples
OPA4317IPW	ACTIVE	TSSOP	PW	14	90	Green (RoHS & no Sb/Br)	CU NIPDAU	Level-2-260C-1 YEAR	-40 to 125	O4317A	Samples
OPA4317IPWR	ACTIVE	TSSOP	PW	14	2000	Green (RoHS & no Sb/Br)	CU NIPDAU	Level-2-260C-1 YEAR	-40 to 125	O4317A	Samples

(1) The marketing status values are defined as follows:

ACTIVE: Product device recommended for new designs.

LIFEBUY: TI has announced that the device will be discontinued, and a lifetime-buy period is in effect.

NRND: Not recommended for new designs. Device is in production to support existing customers, but TI does not recommend using this part in a new design.

PREVIEW: Device has been announced but is not in production. Samples may or may not be available.

OBSELETE: TI has discontinued the production of the device.

⁽²⁾ Eco Plan - The planned eco-friendly classification: Pb-Free (RoHS), Pb-Free (RoHS Exempt), or Green (RoHS & no Sb/Br) - please check <http://www.ti.com/productcontent> for the latest availability information and additional product content details.

TBD: The Pb-Free/Green conversion plan has not been defined.

Pb-Free (RoHS): TI's terms "Lead-Free" or "Pb-Free" mean semiconductor products that are compatible with the current RoHS requirements for all 6 substances, including the requirement that lead not exceed 0.1% by weight in homogeneous materials. Where designed to be soldered at high temperatures, TI Pb-Free products are suitable for use in specified lead-free processes.

Pb-Free (RoHS Exempt): This component has a RoHS exemption for either 1) lead-based flip-chip solder bumps used between the die and package, or 2) lead-based die adhesive used between the die and leadframe. The component is otherwise considered Pb-Free (RoHS compatible) as defined above.

Green (RoHS & no Sb/Br): TI defines "Green" to mean Pb-Free (RoHS compatible), and free of Bromine (Br) and Antimony (Sb) based flame retardants (Br or Sb do not exceed 0.1% by weight in homogeneous material)

⁽³⁾ MSL, Peak Temp. - The Moisture Sensitivity Level rating according to the JEDEC industry standard classifications, and peak solder temperature.

⁽⁴⁾ There may be additional marking, which relates to the logo, the lot trace code information, or the environmental category on the device.

⁽⁵⁾ Multiple Device Markings will be inside parentheses. Only one Device Marking contained in parentheses and separated by a "~" will appear on a device. If a line is indented then it is a continuation of the previous line and the two combined represent the entire Device Marking for that device.

⁽⁶⁾ Lead/Ball Finish - Orderable Devices may have multiple material finish options. Finish options are separated by a vertical ruled line. Lead/Ball Finish values may wrap to two lines if the finish value exceeds the maximum column width.

Important Information and Disclaimer: The information provided on this page represents TI's knowledge and belief as of the date that it is provided. TI bases its knowledge and belief on information provided by third parties, and makes no representation or warranty as to the accuracy of such information. Efforts are underway to better integrate information from third parties. TI has taken and continues to take reasonable steps to provide representative and accurate information but may not have conducted destructive testing or chemical analysis on incoming materials and chemicals. TI and TI suppliers consider certain information to be proprietary, and thus CAS numbers and other limited information may not be available for release.

In no event shall TI's liability arising out of such information exceed the total purchase price of the TI part(s) at issue in this document sold by TI to Customer on an annual basis.

TAPE AND REEL INFORMATION

QUADRANT ASSIGNMENTS FOR PIN 1 ORIENTATION IN TAPE

*All dimensions are nominal

Device	Package Type	Package Drawing	Pins	SPQ	Reel Diameter (mm)	Reel Width W1 (mm)	A0 (mm)	B0 (mm)	K0 (mm)	P1 (mm)	W (mm)	Pin1 Quadrant
OPA2317IDGKR	VSSOP	DGK	8	2500	330.0	12.4	5.3	3.4	1.4	8.0	12.0	Q1
OPA2317IDGKT	VSSOP	DGK	8	250	330.0	12.4	5.3	3.4	1.4	8.0	12.0	Q1
OPA2317IDR	SOIC	D	8	2500	330.0	12.4	6.4	5.2	2.1	8.0	12.0	Q1
OPA317IDBVR	SOT-23	DBV	5	3000	178.0	9.0	3.3	3.2	1.4	4.0	8.0	Q3
OPA317IDBVT	SOT-23	DBV	5	250	178.0	9.0	3.3	3.2	1.4	4.0	8.0	Q3
OPA317IDCKR	SC70	DCK	5	3000	178.0	9.0	2.4	2.5	1.2	4.0	8.0	Q3
OPA317IDCKT	SC70	DCK	5	250	178.0	9.0	2.4	2.5	1.2	4.0	8.0	Q3
OPA317IDR	SOIC	D	8	2500	330.0	12.4	6.4	5.2	2.1	8.0	12.0	Q1
OPA4317IDR	SOIC	D	14	2500	330.0	16.4	6.5	9.0	2.1	8.0	16.0	Q1
OPA4317IPWR	TSSOP	PW	14	2000	330.0	12.4	6.9	5.6	1.6	8.0	12.0	Q1

TAPE AND REEL BOX DIMENSIONS

*All dimensions are nominal

Device	Package Type	Package Drawing	Pins	SPQ	Length (mm)	Width (mm)	Height (mm)
OPA2317IDGKR	VSSOP	DGK	8	2500	364.0	364.0	27.0
OPA2317IDGKT	VSSOP	DGK	8	250	364.0	364.0	27.0
OPA2317IDR	SOIC	D	8	2500	367.0	367.0	35.0
OPA317IDBVR	SOT-23	DBV	5	3000	180.0	180.0	18.0
OPA317IDBVT	SOT-23	DBV	5	250	180.0	180.0	18.0
OPA317IDCKR	SC70	DCK	5	3000	180.0	180.0	18.0
OPA317IDCKT	SC70	DCK	5	250	180.0	180.0	18.0
OPA317IDR	SOIC	D	8	2500	367.0	367.0	35.0
OPA4317IDR	SOIC	D	14	2500	367.0	367.0	38.0
OPA4317IPWR	TSSOP	PW	14	2000	367.0	367.0	35.0

DCK (R-PDSO-G5)

PLASTIC SMALL-OUTLINE PACKAGE



- NOTES:
- A. All linear dimensions are in millimeters.
 - B. This drawing is subject to change without notice.
 - C. Body dimensions do not include mold flash or protrusion. Mold flash and protrusion shall not exceed 0.15 per side.
 - D. Falls within JEDEC MO-203 variation AA.

DCK (R-PDSO-G5)

PLASTIC SMALL OUTLINE





- NOTES:
- All linear dimensions are in millimeters.
 - This drawing is subject to change without notice.
 - Customers should place a note on the circuit board fabrication drawing not to alter the center solder mask defined pad.
 - Publication IPC-7351 is recommended for alternate designs.
 - Laser cutting apertures with trapezoidal walls and also rounding corners will offer better paste release. Customers should contact their board assembly site for stencil design recommendations. Example stencil design based on a 50% volumetric metal load solder paste. Refer to IPC-7525 for other stencil recommendations.

D (R-PDSO-G14)

PLASTIC SMALL OUTLINE



4040047-5/M 06/11

- NOTES:
- A. All linear dimensions are in inches (millimeters).
 - B. This drawing is subject to change without notice.
 -  Body length does not include mold flash, protrusions, or gate burrs. Mold flash, protrusions, or gate burrs shall not exceed 0.006 (0,15) each side.
 -  Body width does not include interlead flash. Interlead flash shall not exceed 0.017 (0,43) each side.
 - E. Reference JEDEC MS-012 variation AB.

D (R-PDSO-G14)

PLASTIC SMALL OUTLINE



- NOTES:
- All linear dimensions are in millimeters.
 - This drawing is subject to change without notice.
 - Publication IPC-7351 is recommended for alternate designs.
 - Laser cutting apertures with trapezoidal walls and also rounding corners will offer better paste release. Customers should contact their board assembly site for stencil design recommendations. Refer to IPC-7525 for other stencil recommendations.
 - Customers should contact their board fabrication site for solder mask tolerances between and around signal pads.

PW (R-PDSO-G14)

PLASTIC SMALL OUTLINE



- NOTES:
- All linear dimensions are in millimeters.
 - This drawing is subject to change without notice.
 - Publication IPC-7351 is recommended for alternate designs.
 - Laser cutting apertures with trapezoidal walls and also rounding corners will offer better paste release. Customers should contact their board assembly site for stencil design recommendations. Refer to IPC-7525 for other stencil recommendations.
 - Customers should contact their board fabrication site for solder mask tolerances between and around signal pads.



D0008A

PACKAGE OUTLINE

SOIC - 1.75 mm max height

SMALL OUTLINE INTEGRATED CIRCUIT



4214825/C 02/2019

NOTES:

- Linear dimensions are in inches [millimeters]. Dimensions in parenthesis are for reference only. Controlling dimensions are in inches. Dimensioning and tolerancing per ASME Y14.5M.
- This drawing is subject to change without notice.
- This dimension does not include mold flash, protrusions, or gate burrs. Mold flash, protrusions, or gate burrs shall not exceed $.006$ [0.15] per side.
- This dimension does not include interlead flash.
- Reference JEDEC registration MS-012, variation AA.

EXAMPLE BOARD LAYOUT

D0008A

SOIC - 1.75 mm max height

SMALL OUTLINE INTEGRATED CIRCUIT



LAND PATTERN EXAMPLE
 EXPOSED METAL SHOWN
 SCALE:8X



SOLDER MASK DETAILS

4214825/C 02/2019

NOTES: (continued)

- 6. Publication IPC-7351 may have alternate designs.
- 7. Solder mask tolerances between and around signal pads can vary based on board fabrication site.

EXAMPLE STENCIL DESIGN

D0008A

SOIC - 1.75 mm max height

SMALL OUTLINE INTEGRATED CIRCUIT



SOLDER PASTE EXAMPLE
BASED ON .005 INCH [0.125 MM] THICK STENCIL
SCALE:8X

4214825/C 02/2019

NOTES: (continued)

8. Laser cutting apertures with trapezoidal walls and rounded corners may offer better paste release. IPC-7525 may have alternate design recommendations.
9. Board assembly site may have different recommendations for stencil design.

DBV0005A



PACKAGE OUTLINE

SOT-23 - 1.45 mm max height

SMALL OUTLINE TRANSISTOR



4214839/D 11/2018

NOTES:

1. All linear dimensions are in millimeters. Any dimensions in parenthesis are for reference only. Dimensioning and tolerancing per ASME Y14.5M.
2. This drawing is subject to change without notice.
3. Reference JEDEC MO-178.
4. Body dimensions do not include mold flash, protrusions, or gate burrs. Mold flash, protrusions, or gate burrs shall not exceed 0.15 mm per side.

EXAMPLE BOARD LAYOUT

DBV0005A

SOT-23 - 1.45 mm max height

SMALL OUTLINE TRANSISTOR



LAND PATTERN EXAMPLE
EXPOSED METAL SHOWN
SCALE:15X



SOLDER MASK DETAILS

4214839/D 11/2018

NOTES: (continued)

- 5. Publication IPC-7351 may have alternate designs.
- 6. Solder mask tolerances between and around signal pads can vary based on board fabrication site.

EXAMPLE STENCIL DESIGN

DBV0005A

SOT-23 - 1.45 mm max height

SMALL OUTLINE TRANSISTOR



SOLDER PASTE EXAMPLE
BASED ON 0.125 mm THICK STENCIL
SCALE:15X

4214839/D 11/2018

NOTES: (continued)

7. Laser cutting apertures with trapezoidal walls and rounded corners may offer better paste release. IPC-7525 may have alternate design recommendations.
8. Board assembly site may have different recommendations for stencil design.



- NOTES:
- A. All linear dimensions are in millimeters.
 - B. This drawing is subject to change without notice.
 - C. Publication IPC-7351 is recommended for alternate designs.
 - D. Laser cutting apertures with trapezoidal walls and also rounding corners will offer better paste release. Customers should contact their board assembly site for stencil design recommendations. Refer to IPC-7525 for other stencil recommendations.
 - E. Customers should contact their board fabrication site for solder mask tolerances between and around signal pads.

IMPORTANT NOTICE AND DISCLAIMER

TI PROVIDES TECHNICAL AND RELIABILITY DATA (INCLUDING DATASHEETS), DESIGN RESOURCES (INCLUDING REFERENCE DESIGNS), APPLICATION OR OTHER DESIGN ADVICE, WEB TOOLS, SAFETY INFORMATION, AND OTHER RESOURCES "AS IS" AND WITH ALL FAULTS, AND DISCLAIMS ALL WARRANTIES, EXPRESS AND IMPLIED, INCLUDING WITHOUT LIMITATION ANY IMPLIED WARRANTIES OF MERCHANTABILITY, FITNESS FOR A PARTICULAR PURPOSE OR NON-INFRINGEMENT OF THIRD PARTY INTELLECTUAL PROPERTY RIGHTS.

These resources are intended for skilled developers designing with TI products. You are solely responsible for (1) selecting the appropriate TI products for your application, (2) designing, validating and testing your application, and (3) ensuring your application meets applicable standards, and any other safety, security, or other requirements. These resources are subject to change without notice. TI grants you permission to use these resources only for development of an application that uses the TI products described in the resource. Other reproduction and display of these resources is prohibited. No license is granted to any other TI intellectual property right or to any third party intellectual property right. TI disclaims responsibility for, and you will fully indemnify TI and its representatives against, any claims, damages, costs, losses, and liabilities arising out of your use of these resources.

TI's products are provided subject to TI's Terms of Sale (www.ti.com/legal/termsofsale.html) or other applicable terms available either on ti.com or provided in conjunction with such TI products. TI's provision of these resources does not expand or otherwise alter TI's applicable warranties or warranty disclaimers for TI products.

Mailing Address: Texas Instruments, Post Office Box 655303, Dallas, Texas 75265
Copyright © 2019, Texas Instruments Incorporated

Looking for pricing, stock, or lifecycle information?

Click below to explore more details on WIN SOURCE:

 [View OPA317IDBVR on WIN SOURCE](#)

 [Texas Instruments](#) Information

Optimize Your Supply Chain with WIN SOURCE Solutions

-  Global Sourcing Solution
-  Obsolete Management
-  Cost Control Management
-  Shortage Management
-  Alternative Solution
-  Excess Inventory Management