

MC100LVE222

3.3 V/5.0 V ECL 1:15 Differential ÷1/÷2 Clock Driver

The MC100LVE222 is a low skew 1:15 differential $\pm 1/\pm 2$ ECL fanout buffer designed with clock distribution in mind. The LVECL/LVPECL input signal pairs can be differential or used single-ended (with V_{BB} output reference bypassed and connected to the unused input of a pair). Either of two fully differential clock inputs may be selected. Each of the four output banks of 2, 3, 4, and 6 differential pairs may be independently configured to fanout 1X or 1/2X of the input frequency. The LVE222 specifically guarantees low output to output skew. Optimal design, layout, and processing minimize skew within a device and from lot to lot.

The fsel pins and CLK_Sel pin are asynchronous control inputs. Any changes may cause indeterminate output states requiring an MR pulse to resynchronize any 1/2X outputs.

The device tpd is affected by the quantity of output pairs terminated with a minimum occurring with only one output pair and increasing about 10–20 ps for all output pairs. Relative skew distribution is not affected as more pairs are terminated, but the increased tpd does shift the entire distribution. Unused output pairs should be left unterminated (open) to reduce power and switching noise.

The MC100LVE222, as with most ECL devices, can be operated from a positive V_{CC}/V_{CCO} supply in PECL mode. This allows the LVE222 to be used for high performance clock distribution in +3.3 V systems. Operation with $>3.8 |V_{CC} \text{ or } V_{CCO} - V_{EE}|$ span will require special thermal handling considerations. Designers can take advantage of the LVE222's performance to distribute low skew clocks across the backplane or the board. In a PECL environment series or Thevenin line, terminations are typically used as they require no additional power supplies. All power supply pins must be connected. For more information on using PECL, designers should refer to Application Note AN1406/D. For a SPICE model, refer to Application Note AN1560/D.

Features

- 200 ps Part-to-Part Skew
 - 50 ps Output-to-Output Skew
 - Selectable 1x or 1/2x Frequency Outputs
 - ESD Protection: >2 kV HBM, >200 V MM
 - The 100 Series Contains Temperature Compensation
 - PECL Mode Operating Range: $V_{CC}/V_{CCO} = 3.0$ V to 5.25 V with $V_{EE} = 0$ V
 - NECL Mode Operating Range: $V_{CC}/V_{CCO} = 0$ V with $V_{EE} = -3.0$ V to -5.25 V
 - Internal Input Pulldown Resistors
 - Meets or Exceeds JEDEC Spec EIA/JESD78 IC Latchup Test
 - Moisture Sensitivity Level 2
- For Additional Information, refer to Application Note AND8003/D
- Flammability Rating: UL 94 V-0 @ 0.125 in, Oxygen Index: 28 to 34
 - Transistor Count = 684 devices
 - Pb-Free Packages are Available*

*For additional information on our Pb-Free strategy and soldering details, please download the ON Semiconductor Soldering and Mounting Techniques Reference Manual, SOLDERRM/D.



ON Semiconductor®

<http://onsemi.com>

MARKING DIAGRAM*

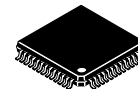

LQFP
FA SUFFIX
CASE 848D

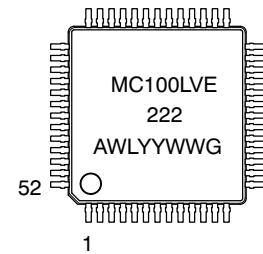

A = Assembly Location
WL = Wafer Lot
YY = Year
WW = Work Week
G = Pb-Free

*For additional information, see Application Note AND8002/D

ORDERING INFORMATION

See detailed ordering and shipping information in the package dimensions section on page 6 of this data sheet.

MC100LVE222

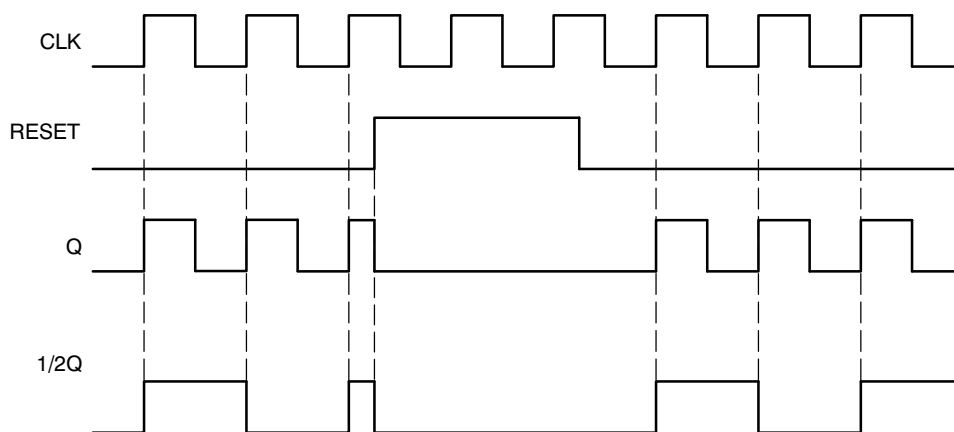

Figure 3. Timing Diagram

Table 3. MAXIMUM RATINGS

Symbol	Parameter	Condition 1	Condition 2	Rating	Unit
V_{CC}/V_{CCO}	PECL Mode Power Supply	$V_{EE} = 0\text{ V}$		8 to 0	V
V_{EE}	NECL Mode Power Supply	V_{CC} or $V_{CCO} = 0\text{ V}$		-8 to 0	V
V_I	PECL Mode Input Voltage NECL Mode Input Voltage	$V_{EE} = 0\text{ V}$ V_{CC} or $V_{CCO} = 0\text{ V}$	$V_I \leq (V_{CC}$ or $V_{CCO})$ $V_I \geq V_{EE}$	6 to 0 -6 to 0	V V
I_{out}	Output Current	Continuous Surge		50 100	mA mA
I_{BB}	V_{BB} Sink/Source			± 0.5	mA
T_A	Operating Temperature Range			-40 to +85	$^{\circ}\text{C}$
T_{stg}	Storage Temperature Range			-65 to +150	$^{\circ}\text{C}$
θ_{JA}	Thermal Resistance (Junction-to-Ambient)	0 lfpm 500 lfpm	52 LQFP 52 LQFP	35.6 30	$^{\circ}\text{C}/\text{W}$ $^{\circ}\text{C}/\text{W}$
θ_{JC}	Thermal Resistance (Junction-to-Case)	Standard Board	52 LQFP	21	$^{\circ}\text{C}/\text{W}$
T_{sol}	Wave Solder	<2 to 3 sec @ 248 $^{\circ}\text{C}$		265	$^{\circ}\text{C}$

Stresses exceeding Maximum Ratings may damage the device. Maximum Ratings are stress ratings only. Functional operation above the Recommended Operating Conditions is not implied. Extended exposure to stresses above the Recommended Operating Conditions may affect device reliability.

MC100LVE222

Table 4. LVPECL DC CHARACTERISTICS V_{CC} or $V_{CCO} = 3.3$ V; $V_{EE} = 0.0$ V (Note 1)

Symbol	Characteristic	-40°C			25°C			85°C			Unit
		Min	Typ	Max	Min	Typ	Max	Min	Typ	Max	
I_{EE}	Power Supply Current		122	136		122	136		125	139	mA
V_{OH}	Output HIGH Voltage (Note 2)	2215	2295	2420	2275	2345	2420	2275	2345	2420	mV
V_{OL}	Output LOW Voltage (Note 2)	1470	1605	1745	1490	1595	1680	1490	1595	1680	mV
V_{IH}	Input HIGH Voltage (Single-Ended)	2135		2420	2135		2420	2135		2420	mV
V_{IL}	Input LOW Voltage (Single-Ended)	1490		1825	1490		1825	1490		1825	mV
V_{BB}	Output Voltage Reference	1.92		2.04	1.92		2.04	1.92		2.04	V
V_{IHCMR}	Input HIGH Voltage Common Mode Range (Differential Configuration) (Note 6)										
	$V_{PP} < 500$ mV	1.3		2.9	1.2		2.9	1.2		2.9	V
	$V_{PP} \geq 500$ mV	1.6		2.9	1.5		2.9	1.5		2.9	V
I_{IH}	Input HIGH Current			150			150			150	μ A
I_{IL}	Input LOW Current										
	Others CLK0, CLK1	0.5 -300			0.5 -300			0.5 -300			μ A μ A

NOTE: Device will meet the specifications after thermal equilibrium has been established when mounted in a test socket or printed circuit board with maintained transverse airflow greater than 500 lfm. Electrical parameters are guaranteed only over the declared operating temperature range. Functional operation of the device exceeding these conditions is not implied. Device specification limit values are applied individually under normal operating conditions and not valid simultaneously.

1. Input and output parameters vary 1:1 with V_{CC}/V_{CCO} . V_{EE} can vary +0.3 V to -1.95 V. Operation with $|V_{CC}$ or $V_{CCO}-V_{EE}| \geq 3.8$ V span will require special thermal handling considerations.
2. Outputs are terminated through a 50 Ω resistor to (V_{CC} or V_{CCO}) - 2.0 V.
3. V_{IHCMR} min varies 1:1 with V_{EE} , max varies 1:1 with V_{CC}/V_{CCO} . V_{IHCMR} is defined as the range within which the V_{IH} level may vary, with the device still meeting the propagation delay specification. The V_{IL} level must be such that the peak to peak voltage is less than 1.0 V and greater than or equal to $V_{PP}(\text{min})$.

Table 5. LVNECL DC CHARACTERISTICS V_{CC} or $V_{CCO} = 0.0$ V; $V_{EE} = -3.3$ V (Note 4)

Symbol	Characteristic	-40°C			25°C			85°C			Unit
		Min	Typ	Max	Min	Typ	Max	Min	Typ	Max	
I_{EE}	Power Supply Current		122	136		122	136		125	139	mA
V_{OH}	Output HIGH Voltage (Note 5)	-1085	-1005	-880	-1025	-955	-880	-1025	-955	-880	mV
V_{OL}	Output LOW Voltage (Note 5)	-1830	-1695	-1555	-1810	-1705	-1620	-1810	-1705	-1620	mV
V_{IH}	Input HIGH Voltage (Single-Ended)	-1165		-880	-1165		-880	-1165		-880	mV
V_{IL}	Input LOW Voltage (Single-Ended)	-1810		-1475	-1810		-1475	-1810		-1475	mV
V_{BB}	Output Voltage Reference	-1.38		-1.26	-1.38		-1.26	-1.38		-1.26	V
V_{IHCMR}	Input HIGH Voltage Common Mode Range (Differential Configuration) (Note 6)										
	$V_{PP} < 500$ mV	-2.0		-0.4	-2.1		-0.4	-2.1		-0.4	V
	$V_{PP} \geq 500$ mV	-1.7		-0.4	-1.8		-0.4	-1.8		-0.4	V
I_{IH}	Input HIGH Current			150			150			150	μ A
I_{IL}	Input LOW Current										
	Others CLK0, CLK1	0.5 -300			0.5 -300			0.5 -300			μ A μ A

NOTE: Device will meet the specifications after thermal equilibrium has been established when mounted in a test socket or printed circuit board with maintained transverse airflow greater than 500 lfm. Electrical parameters are guaranteed only over the declared operating temperature range. Functional operation of the device exceeding these conditions is not implied. Device specification limit values are applied individually under normal operating conditions and not valid simultaneously.

4. Input and output parameters vary 1:1 with V_{CC}/V_{CCO} . V_{EE} can vary +0.3 V to -1.95 V. Operation with $|V_{CC}$ or $V_{CCO}-V_{EE}| \geq 3.8$ V span will require special thermal handling considerations.
5. Outputs are terminated through a 50 Ω resistor to (V_{CC} or V_{CCO}) - 2.0 V.
6. V_{IHCMR} min varies 1:1 with V_{EE} , max varies 1:1 with V_{CC}/V_{CCO} . V_{IHCMR} is defined as the range within which the V_{IH} level may vary, with the device still meeting the propagation delay specification. The V_{IL} level must be such that the peak to peak voltage is less than 1.0 V and greater than or equal to $V_{PP}(\text{min})$.

MC100LVE222

Table 6. AC CHARACTERISTICS V_{CC} or $V_{CCO} = 3.3$ V; $V_{EE} = 0.0$ V or $V_{CC}/V_{CCO} = 0.0$ V; $V_{EE} = -3.3$ V (Note 7)

Symbol	Characteristic	-40°C			25°C			70°C			Unit
		Min	Typ	Max	Min	Typ	Max	Min	Typ	Max	
f_{max}	Maximum Toggle Frequency	1.2	> 1.5		1.2	> 1.5		1.2	> 1.5		GHz
t_{PLH} t_{PHL}	Propagation Delay to Output IN (differential) (Note 8) IN (single-ended) (Note 9) MR	1040 940 1100	1140 1140 1250	1240 1290 1400	1080 980 1170	1180 1180 1320	1280 1330 1470	1120 1020 1220	1220 1220 1370	1320 1370 1520	ps
t_{skew}	Within-Device Skew (Note 10) Part-to-Part Skew (Differential Configuration)			50 200			50 200			50 200	ps
t_{JITTER}	Random CLOCK Jitter (RMS)		< 1.0			< 1.0			< 1.0		ps
V_{PP}	Input Swing (Differential) (Note 11)	400		1000	400		1000	400		1000	mV
t_r/t_f	Output Rise/Fall Time 20%-80%	200		600	200		600	200		600	ps

NOTE: Device will meet the specifications after thermal equilibrium has been established when mounted in a test socket or printed circuit board with maintained transverse airflow greater than 500 lfm. Electrical parameters are guaranteed only over the declared operating temperature range. Functional operation of the device exceeding these conditions is not implied. Device specification limit values are applied individually under normal operating conditions and not valid simultaneously.

7. V_{EE} can vary +0.3 V to -1.95 V. Operation with $|V_{CC}$ or $pV_{CCO} - V_{EE}| \geq 3.8$ V span will require special thermal handling considerations.
8. The differential propagation delay is defined as the delay from the crossing points of the differential input signals to the crossing point of the differential output signals.
9. The single-ended propagation delay is defined as the delay from the 50% point of the input signal to the 50% point of the output signal.
10. The within-device skew is defined as the worst case difference between any two similar delay paths within a single device.
11. $V_{PP}(\min)$ is defined as the minimum input differential voltage which will cause no increase in the propagation delay. The $V_{PP}(\min)$ is AC limited for the LVE222. A differential input as low as 50 mV will still produce full ECL levels at the output.

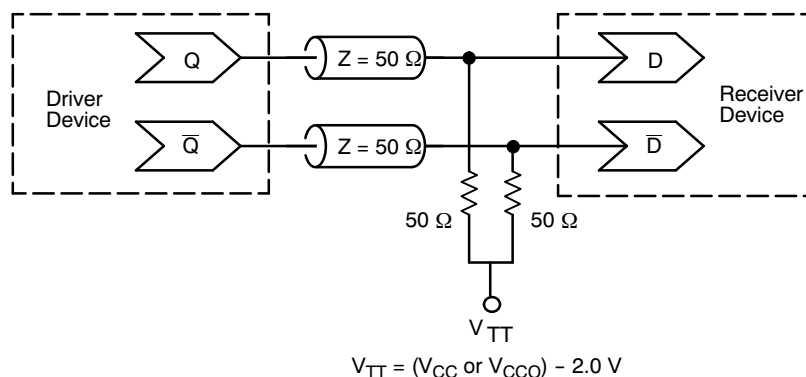

Figure 4. Typical Termination for Output Driver and Device Evaluation
(Refer to Application Note AND8020 – Termination of ECL Logic Devices)

MC100LVE222

ORDERING INFORMATION

Device	Package	Shipping†
MC100LVE222FA	LQFP-52	160 Units / Rail
MC100LVE222FAG	LQFP-52 (Pb-Free)	160 Units / Rail
MC100LVE222FAR2	LQFP-52	1500 / Tape & Reel
MC100LVE222FAR2G	LQFP-52 (Pb-Free)	1500 / Tape & Reel

†For information on tape and reel specifications, including part orientation and tape sizes, please refer to our Tape and Reel Packaging Specifications Brochure, BRD8011/D.

Resource Reference of Application Notes

- AN1404** - ECLinPS™ Circuit Performance at Non-Standard V_{IH} Levels
- AN1405** - ECL Clock Distribution Techniques
- AN1406** - Designing with PECL (ECL at +5.0 V)
- AN1503** - ECLinPS I/O SPICE Modeling Kit
- AN1504** - Metastability and the ECLinPS Family
- AN1560** - Low Voltage ECLinPS SPICE Modeling Kit
- AN1568** - Interfacing Between LVDS and ECL
- AN1596** - ECLinPS Lite Translator ELT Family SPICE I/O Model Kit
- AN1650** - Using Wire-OR Ties in ECLinPS Designs
- AN1672** - The ECL Translator Guide
- AND8001** - Odd Number Counters Design
- AND8002** - Marking and Date Codes
- AND8020** - Termination of ECL Logic Devices
- AND8020** - Termination of ECL Logic Devices

MC100LVE222

PACKAGE DIMENSIONS

FA SUFFIX
LQFP PACKAGE
CASE 848D-03
ISSUE D

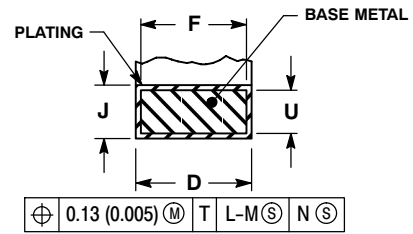
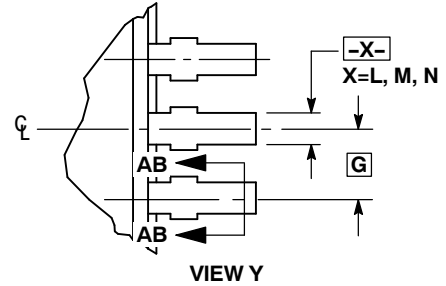
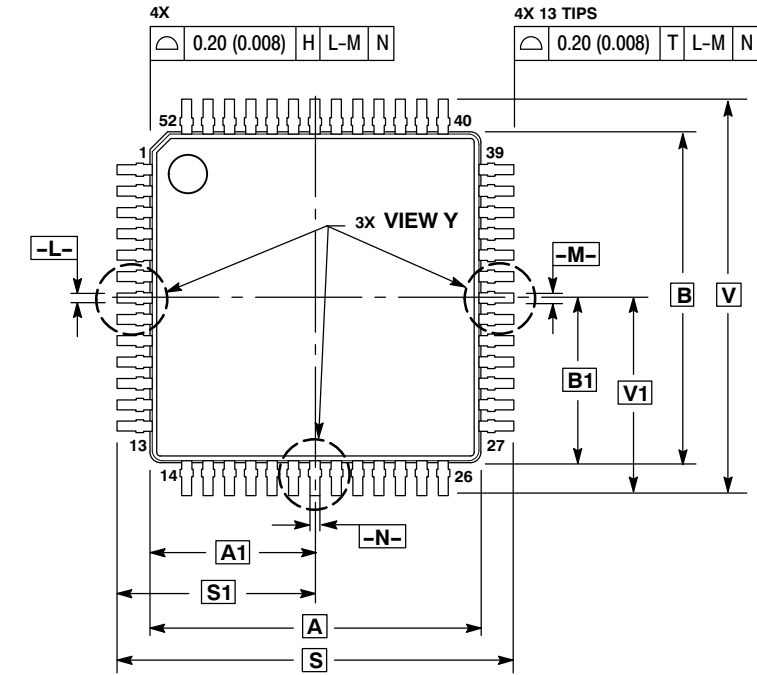

SECTION AB-AB
ROTATED 90° CLOCKWISE

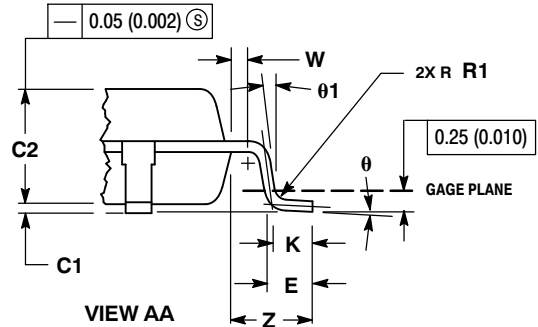
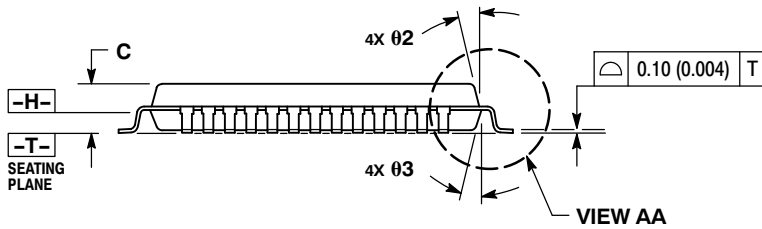

NOTES:

- DIMENSIONING AND TOLERANCING PER ANSI Y14.5M, 1982.
- CONTROLLING DIMENSION: MILLIMETER.
- DATUM PLANE -H- IS LOCATED AT BOTTOM OF LEAD AND IS COINCIDENT WITH THE LEAD WHERE THE LEAD EXITS THE PLASTIC BODY AT THE BOTTOM OF THE PARTING LINE.
- DATUMS -L-, -M- AND -N- TO BE DETERMINED AT DATUM PLANE -H-.
- DIMENSIONS S AND V TO BE DETERMINED AT SEATING PLANE -T-.
- DIMENSIONS A AND B DO NOT INCLUDE MOLD PROTRUSION. ALLOWABLE PROTRUSION IS 0.25 (0.010) PER SIDE. DIMENSIONS A AND B DO NOT INCLUDE MOLD MISMATCH AND ARE DETERMINED AT DATUM PLANE -H-.
- DIMENSION D DOES NOT INCLUDE DAMBAR PROTRUSION. DAMBAR PROTRUSION SHALL NOT CAUSE THE LEAD WIDTH TO EXCEED 0.46 (0.018). MINIMUM SPACE BETWEEN PROTRUSION AND ADJACENT LEAD OR PROTRUSION 0.07 (0.003).

DIM	MILLIMETERS		INCHES	
	MIN	MAX	MIN	MAX
A	10.00 BSC		0.394 BSC	
A1	5.00 BSC		0.197 BSC	
B	10.00 BSC		0.394 BSC	
B1	5.00 BSC		0.197 BSC	
C	---	1.70	---	0.067
C1	0.05	0.20	0.002	0.008
C2	1.30	1.50	0.051	0.059
D	0.20	0.40	0.008	0.016
E	0.45	0.75	0.018	0.030
F	0.22	0.35	0.009	0.014
G	0.65 BSC		0.026 BSC	
J	0.07	0.20	0.003	0.008
K	0.50 REF		0.020 REF	
R1	0.08	0.20	0.003	0.008
S	12.00 BSC		0.472 BSC	
S1	6.00 BSC		0.236 BSC	
U	0.09	0.16	0.004	0.006
V	12.00 BSC		0.472 BSC	
V1	6.00 BSC		0.236 BSC	
W	0.20 REF		0.008 REF	
Z	1.00 REF		0.039 REF	
Ø	0°	7°	0°	7°
Ø1	0°	---	0°	---
Ø2	12° REF		12° REF	
Ø3	12° REF		12° REF	

MC100LVE222

ECLinPS is a trademark of Semiconductor Components Industries, LLC (SCILLC).

ON Semiconductor and  are registered trademarks of Semiconductor Components Industries, LLC (SCILLC). SCILLC reserves the right to make changes without further notice to any products herein. SCILLC makes no warranty, representation or guarantee regarding the suitability of its products for any particular purpose, nor does SCILLC assume any liability arising out of the application or use of any product or circuit, and specifically disclaims any and all liability, including without limitation special, consequential or incidental damages. "Typical" parameters which may be provided in SCILLC data sheets and/or specifications can and do vary in different applications and actual performance may vary over time. All operating parameters, including "Typicals" must be validated for each customer application by customer's technical experts. SCILLC does not convey any license under its patent rights nor the rights of others. SCILLC products are not designed, intended, or authorized for use as components in systems intended for surgical implant into the body, or other applications intended to support or sustain life, or for any other application in which the failure of the SCILLC product could create a situation where personal injury or death may occur. Should Buyer purchase or use SCILLC products for any such unintended or unauthorized application, Buyer shall indemnify and hold SCILLC and its officers, employees, subsidiaries, affiliates, and distributors harmless against all claims, costs, damages, and expenses, and reasonable attorney fees arising out of, directly or indirectly, any claim of personal injury or death associated with such unintended or unauthorized use, even if such claim alleges that SCILLC was negligent regarding the design or manufacture of the part. SCILLC is an Equal Opportunity/Affirmative Action Employer. This literature is subject to all applicable copyright laws and is not for resale in any manner.

PUBLICATION ORDERING INFORMATION

LITERATURE FULFILLMENT:

Literature Distribution Center for ON Semiconductor
P.O. Box 5163, Denver, Colorado 80217 USA
Phone: 303-675-2175 or 800-344-3860 Toll Free USA/Canada
Fax: 303-675-2176 or 800-344-3867 Toll Free USA/Canada
Email: orderlit@onsemi.com

N. American Technical Support: 800-282-9855 Toll Free
USA/Canada
Europe, Middle East and Africa Technical Support:
Phone: 421 33 790 2910
Japan Customer Focus Center
Phone: 81-3-5773-3850

ON Semiconductor Website: www.onsemi.com

Order Literature: <http://www.onsemi.com/orderlit>

For additional information, please contact your local Sales Representative

Looking for pricing, stock, or lifecycle information?

Click below to explore more details on WIN SOURCE:

 [View MC100LVE222FA on WIN SOURCE](#)

 [ON Semiconductor](#) Information

Optimize Your Supply Chain with WIN SOURCE Solutions

-  Global Sourcing Solution
-  Obsolete Management
-  Cost Control Management
-  Shortage Management
-  Alternative Solution
-  Excess Inventory Management