



**THE DATASHEET OF  
NCV8800HDW75**



# NCV8800 Series

## Synchronous Buck Regulator with 1.0 Amp Switch

The NCV8800 is an automotive synchronous step-down buck regulator. This part provides an efficient step-down voltage compared to linear regulators. The NCV8800 uses very few external components allowing for maximum use of printed circuit board space.

### Features

- Output Voltage Options: 2.6 V, 3.3 V, 5.0 V, 7.5 V
- $\pm 3.0\%$  Output
- 3.5 V Operation
- AUXILIARY Hold Up Pin (for Cranking Conditions)
- On-Chip Switching Power Devices ( $0.4 \Omega R_{DS(ON)}$ )
- Constant Frequency
- Synchronous Operation
- On-Chip Charge Pump Control Circuitry
- Nonoverlap Logic
- Power Up Sequencing Control Option (2.6 V and 3.3 V Only)
- ENABLE Battery Voltage Capable Option
- Selectable Reset Delay
- Dual Pin Feedback Connection
- $V^2$ ™ Control Topology
- Internally Fused Leads in SO-16L Package
- NCV Prefix for Automotive and Other Applications Requiring Site and Change Control
- **These devices are available in Pb-free package(s). Specifications herein apply to both standard and Pb-free devices. Please see our website at [www.onsemi.com](http://www.onsemi.com) for specific Pb-free orderable part numbers, or contact your local ON Semiconductor sales office or representative.**

### Typical Applications

- Telecommunications
- Mobile Multimedia
- Instrumentation
- Automotive Entertainment Systems



ON Semiconductor®

<http://onsemi.com>

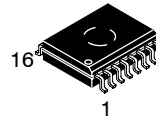

SO-16L  
DW SUFFIX  
CASE 751G

### PIN CONNECTIONS AND MARKING DIAGRAM

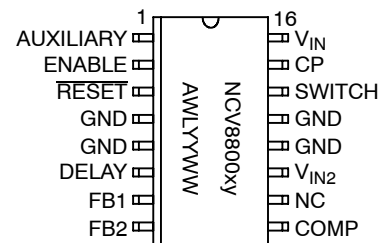

- x = Voltage Ratings as Indicated Below:
  - 2 = 2.6 V
  - 3 = 3.3 V
  - 5 = 5.0 V
  - 7 = 7.5 V
- y = ENABLE Option as Indicated Below:
  - S = Sequenced
  - H = High Voltage
- A = Assembly Location
- WL, L = Wafer Lot
- YY, Y = Year
- WW, W = Work Week

### ORDERING INFORMATION

See detailed ordering and shipping information in the package dimensions section on page 12 of this data sheet.

# NCV8800 Series

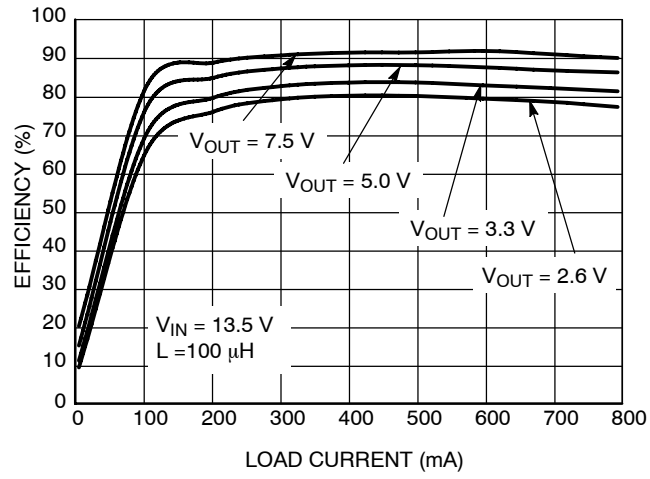

Figure 1. Efficiency vs. Load Current

# NCV8800 Series

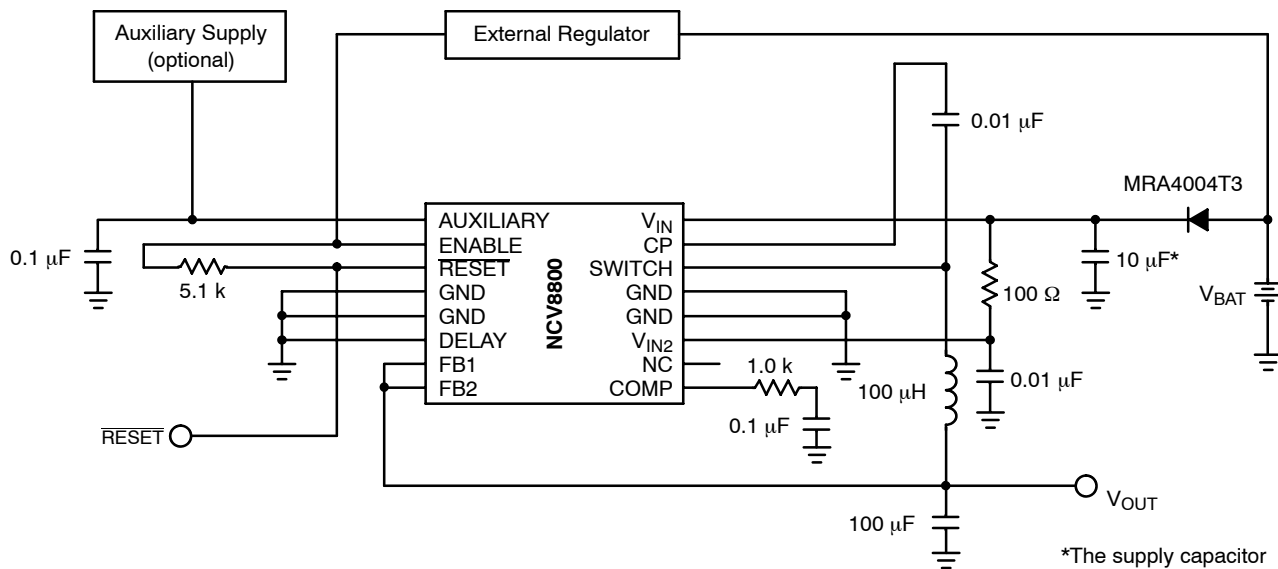

Figure 2. Application Diagram

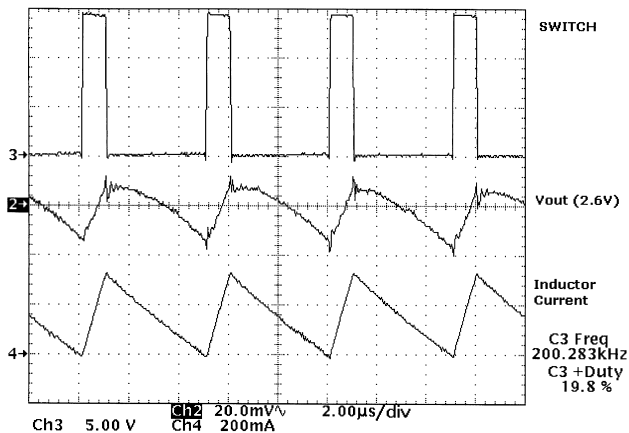

Figure 3. Typical Operation With An 8.0 Ω Load

## NCV8800 Series

### MAXIMUM RATINGS\*

Rating	Value	Unit
Supply Voltages, $V_{IN}$ , $V_{IN2}$	-0.3 to 45	V
AUXILIARY	-0.3 to 8.0	V
ENABLE (Sequenced Option)	-0.3 to 7.0	V
ENABLE (High Voltage Option)	-0.3 to 8.0	V
RESET	-0.3 to 30	V
DELAY	-0.3 to 7.0	V
SWITCH ( $V_{5VSENSE} = 0$ V)	-1.0 to 45	V
Operating Junction Temperature	-40 to 150	°C
Storage Temperature Range	-55 to 150	°C
ESD - Human Body Model (AUXILIARY, ENABLE, RESET, DELAY, FB1, FB2, CP, SWITCH, COMP)	2.0	kV
Human Body Model ( $V_{IN}$ , $V_{IN2}$ )	1.3	kV
Machine Model (All Pins)	200	V
Package Thermal Resistance, SO-16L		°C/W
Junction-to-Case, $R_{\theta JC}$	18	
Junction-to-Ambient, $R_{\theta JA}$	80	
Lead Temperature Soldering:	Reflow (SMD Style Only) (Note 1)	240 Peak (Note 2)
		°C

1. 60 second maximum above 183°C.
2. -5°C/+0°C allowable condition.

\*The maximum package power dissipation must be observed.

## NCV8800 Series

**ELECTRICAL CHARACTERISTICS** ( $-40^{\circ}\text{C} \leq T_J \leq 125^{\circ}\text{C}$ ; Sequenced ENABLE Option:  $3.5\text{ V} \leq V_{\text{IN}} \leq 16\text{ V}$ ,  $3.5\text{ V} \leq V_{\text{IN}2} \leq 16\text{ V}$ , AUXILIARY = 6.0 V, ENABLE = 5.0 V; High Voltage ENABLE Option:  $6.0\text{ V} \leq V_{\text{IN}} \leq 16\text{ V}$ ,  $6.0\text{ V} \leq V_{\text{IN}2} \leq 16\text{ V}$ ; unless otherwise stated.)

Characteristic	Test Conditions	Min	Typ	Max	Unit
----------------	-----------------	-----	-----	-----	------

### General

Quiescent Current ( $V_{\text{IN}2}$ ) Sleep Mode Operating	ENABLE = 0 V, $V_{\text{IN}} = 12.6\text{ V}$ , $T_J = -40^{\circ}\text{C}$	-	-	40	$\mu\text{A}$
	ENABLE = 0 V, $V_{\text{IN}} = 12.6\text{ V}$ , $T_J = 25^{\circ}\text{C}$ , $125^{\circ}\text{C}$	-	-	30	$\mu\text{A}$
	ENABLE = 5.0 V, $V_{\text{IN}} = 13.5\text{ V}$ , $I_{\text{OUT}} = 0$	-	-	15	mA
Switching Frequency	-	180	200	230	kHz
Switching Duty Cycle	-	85	90	95	%
Thermal Shutdown	Note 3	150	165	200	$^{\circ}\text{C}$

### Feedback

Feedback Voltage Threshold, 2.6 V Option ( $V_{\text{FB}}$ )	-	2.522	2.6	2.678	V
Feedback Voltage Threshold, 3.3 V Option ( $V_{\text{FB}}$ )	-	3.201	3.3	3.399	V
Feedback Voltage Threshold, 5.0 V Option ( $V_{\text{FB}}$ )	-	4.850	5.0	5.150	V
Feedback Voltage Threshold, 7.5 V Option ( $V_{\text{FB}}$ )	-	7.275	7.5	7.725	V

### RESET

Undervoltage $\overline{\text{RESET}}$ Threshold, 2.6 V Option	$V_{\text{OUT}}$ Increasing	2.44	-	$V_{\text{FB}}$	V
	$V_{\text{OUT}}$ Decreasing	2.40	-	$V_{\text{FB}} - 0.04$	V
Undervoltage $\overline{\text{RESET}}$ Hysteresis, 2.6 V Option	-	40	-	-	mV
Overvoltage $\overline{\text{RESET}}$ Threshold, 2.6 V Option	$V_{\text{OUT}}$ Increasing	$V_{\text{FB}} + 0.04$	-	2.80	V
	$V_{\text{OUT}}$ Decreasing	$V_{\text{FB}}$	-	2.76	V
Overvoltage $\overline{\text{RESET}}$ Hysteresis, 2.6 V Option	-	40	-	-	mV
Undervoltage $\overline{\text{RESET}}$ Threshold, 3.3 V Option	$V_{\text{OUT}}$ Increasing	3.10	-	$V_{\text{FB}}$	V
	$V_{\text{OUT}}$ Decreasing	3.04	-	$V_{\text{FB}} - 0.05$	V
Undervoltage $\overline{\text{RESET}}$ Hysteresis, 3.3 V Option	-	50	-	-	mV
Overvoltage $\overline{\text{RESET}}$ Threshold, 3.3 V Option	$V_{\text{OUT}}$ Increasing	$V_{\text{FB}} + 0.05$	-	3.56	V
	$V_{\text{OUT}}$ Decreasing	$V_{\text{FB}}$	-	3.51	V
Overvoltage $\overline{\text{RESET}}$ Hysteresis, 3.3 V Option	-	50	-	-	mV
Undervoltage $\overline{\text{RESET}}$ Threshold, 5.0 V Option	$V_{\text{OUT}}$ Increasing	4.70	-	$V_{\text{FB}}$	V
	$V_{\text{OUT}}$ Decreasing	4.61	-	$V_{\text{FB}} - 0.075$	V
Undervoltage $\overline{\text{RESET}}$ Hysteresis, 5.0 V Option	-	75	-	-	mV
Overvoltage $\overline{\text{RESET}}$ Threshold, 5.0 V Option	$V_{\text{OUT}}$ Increasing	$V_{\text{FB}} + 0.075$	-	5.39	V
	$V_{\text{OUT}}$ Decreasing	$V_{\text{FB}}$	-	5.31	V
Overvoltage $\overline{\text{RESET}}$ Hysteresis, 5.0 V Option	-	75	-	-	mV
Undervoltage $\overline{\text{RESET}}$ Threshold, 7.5 V Option	$V_{\text{OUT}}$ Increasing	7.05	-	$V_{\text{FB}}$	V
	$V_{\text{OUT}}$ Decreasing	6.92	-	$V_{\text{FB}} - 0.115$	V
Undervoltage $\overline{\text{RESET}}$ Hysteresis, 7.5 V Option	-	115	-	-	mV
Overvoltage $\overline{\text{RESET}}$ Threshold, 7.5 V Option	$V_{\text{OUT}}$ Increasing	$V_{\text{FB}} + 0.115$	-	8.08	V
	$V_{\text{OUT}}$ Decreasing	$V_{\text{FB}}$	-	7.96	V
Overvoltage $\overline{\text{RESET}}$ Hysteresis, 7.5 V Option	-	115	-	-	mV

3. Guaranteed By Design.

## NCV8800 Series

**ELECTRICAL CHARACTERISTICS (continued)** ( $-40^{\circ}\text{C} \leq T_J \leq 125^{\circ}\text{C}$ ; Sequenced ENABLE Option:  $3.5\text{ V} \leq V_{\text{IN}} \leq 16\text{ V}$ ,  $3.5\text{ V} \leq V_{\text{IN}2} \leq 16\text{ V}$ , AUXILIARY = 6.0 V, ENABLE = 5.0 V; High Voltage ENABLE Option:  $6.0\text{ V} \leq V_{\text{IN}} \leq 16\text{ V}$ ,  $6.0\text{ V} \leq V_{\text{IN}2} \leq 16\text{ V}$ ; unless otherwise stated.)

Characteristic	Test Conditions	Min	Typ	Max	Unit
----------------	-----------------	-----	-----	-----	------

### RESET

RESET Leakage Current	RESET = 5.25 V	-	-	25	$\mu\text{A}$
RESET Output Low Voltage	I <sub>OUT</sub> = 1.6 mA	-	-	0.4	V
RESET Delay	DELAY Connected to FB1, FB2 DELAY = 0 V	28.70 14.35	32.60 16.30	36.66 18.33	ms ms

### ENABLE

ENABLE Threshold	Increasing Decreasing	1.1 1.0	1.9 1.6	2.3 2.2	V V
ENABLE Hysteresis	-	100	250	550	mV
ENABLE Input Resistance	ENABLE = 5.25 V, V <sub>IN2</sub> = 13.5 V	50	100	200	k $\Omega$

### DELAY

DELAY Input Current	DELAY = 5.15 V	4.0	10	16	$\mu\text{A}$
---------------------	----------------	-----	----	----	---------------

### SWITCH

SWITCH ON Resistance	I <sub>SWITCH</sub> = 0.5 A, T <sub>J</sub> = -40°C, 25°C I <sub>SWITCH</sub> = 0.5 A, T <sub>J</sub> = 125°C	- -	0.40 0.55	0.60 0.75	$\Omega$ $\Omega$
Current Limit	-	1.0	1.6	2.5	A

### Error Amplifier

Error Amplifier Transconductance	2.6 V Option	2.58 V $\leq$ FB1 $\leq$ 2.62 V 2.58 V $\leq$ FB2 $\leq$ 2.62 V	0.55	-	2.10	1/m $\Omega$
	3.3 V Option	3.275 V $\leq$ FB1 $\leq$ 3.325 V 3.275 V $\leq$ FB2 $\leq$ 3.325 V	0.43	-	1.65	
	5.0 V Option	4.962 V $\leq$ FB1 $\leq$ 5.038 V 4.962 V $\leq$ FB2 $\leq$ 5.038 V	0.28	-	1.09	
	7.5 V Option	7.442 V $\leq$ FB1 $\leq$ 7.558 V 7.442 V $\leq$ FB2 $\leq$ 7.558 V	0.19	-	0.73	
Error Amplifier Bandwidth	Note 4	1.0	-	-	MHz	

### Output Tracking (Sequencing)

Feedback to ENABLE Tracking Voltage, 2.6 V Option	-	60	67	75	%
Feedback to ENABLE Tracking Voltage, 3.3 V Option	-	80	85	90	%

4. Guaranteed By Design.

## NCV8800 Series

### PACKAGE PIN DESCRIPTION

PACKAGE LEAD #	LEAD SYMBOL	FUNCTION
1	AUXILIARY	Alternate path for voltage input to the IC.
2	ENABLE	Sense for powerup. This pin must be high before SWITCH turns on.
3	RESET	CMOS compatible open drain output lead. RESET goes low whenever FB1 or FB2 is below the RESET low threshold, or above the RESET high threshold.
4, 5, 12, 13	GND	Ground.
6	DELAY	RESET delay control. Time is doubled when pin moved to FB1 or FB2 from 0 V.
7	FB1	Voltage feedback to error amplifier. Shorted with FB2.
8	FB2	Voltage feedback to error amplifier. Shorted with FB1.
9	COMP	Loop compensation node for error amplifier. (1.0 k $\Omega$ and 0.1 $\mu$ F to ground).
10	NC	No connection.
11	V <sub>IN2</sub>	Supply input voltage for internal bias circuitry.
14	SWITCH	Drive for external inductor.
15	CP	Node for charge pump bootstrap capacitor.
16	V <sub>IN</sub>	Supply input voltage for output drivers.

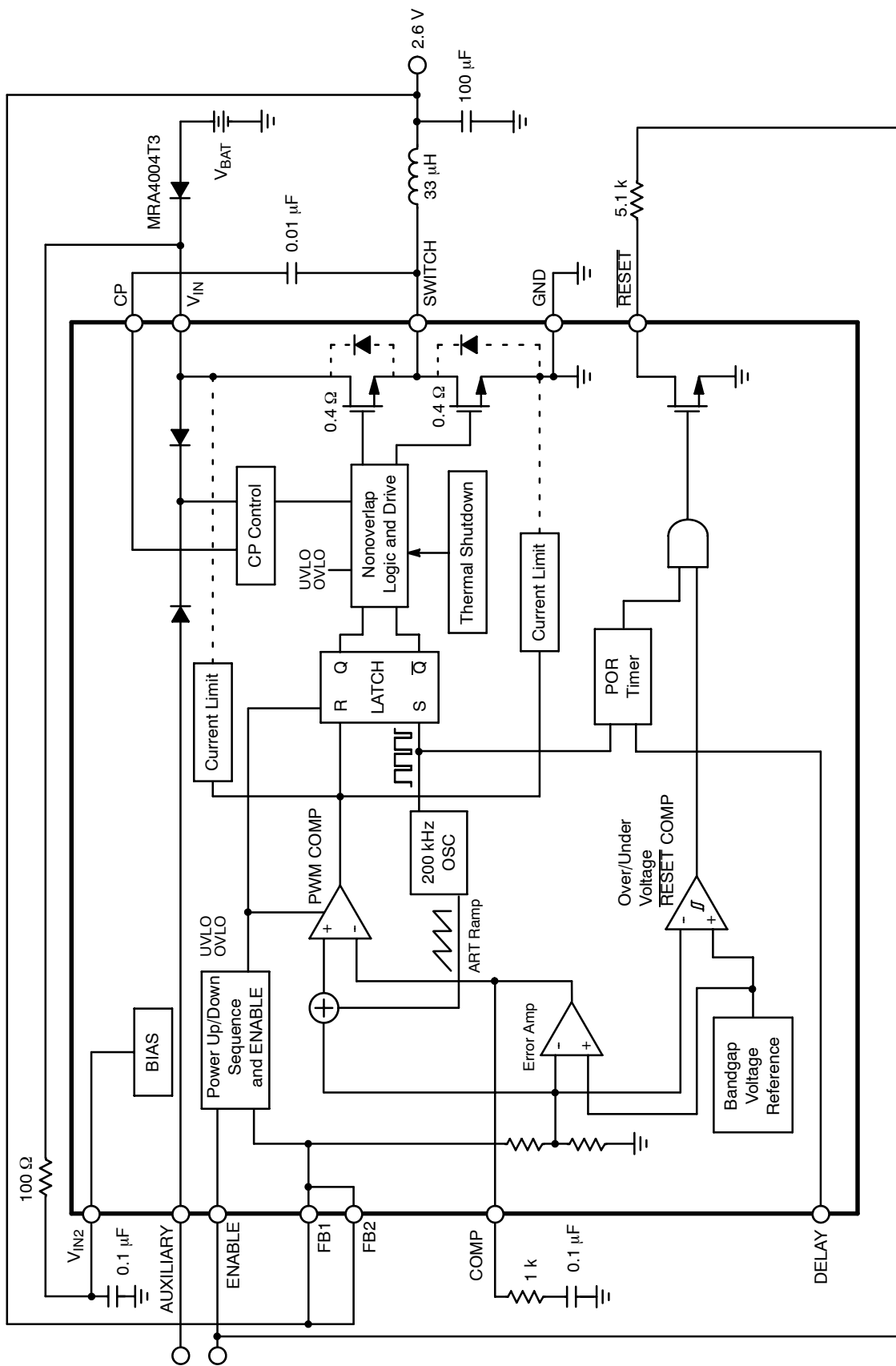

Figure 4. Block Diagram

## CIRCUIT DESCRIPTION

### ENABLE

The NCV8800 remains in sleep mode drawing less than 25  $\mu$ A of quiescent current until the ENABLE pin is brought high powering up the device. There are two options available for the ENABLE feature.

- Option 1 (Sequenced). The output voltage tracks the ENABLE pin with a maximum delta voltage between them (reference the Output Tracking specs in the Electrical Characteristics). This allows the device to be used with microprocessors requiring dual supply voltages. One voltage is typically needed to power the core of the microprocessor, and another high voltage is needed to power the microprocessor I/O.
- Option 2 (High Voltage). This option removes the sequencing feature above, and allows the device to be controlled up to the battery voltage on the ENABLE pin with an external resistor (10 k). See Figure 5.

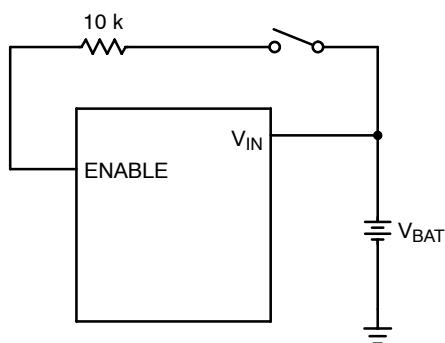

Figure 5. Switched Battery Application

### AUXILIARY

The AUXILIARY pin provides an alternate path for the IC to maintain operation. The AUXILIARY pin is diode OR'd with the  $V_{IN}$  pin to the control circuitry (the DMOS output drivers are not included). If the voltage ( $V_{IN}$ ) from the battery dips as low as 3.5 V during a crank condition, the NCV8800 will maintain operation through a 6.0 V(min) connection on the AUXILIARY pin. Using this feature is optional. This pin should be grounded when not in use.

### $V_{IN}$

Normal supply voltage input. An external diode must be provided to afford reverse battery protection.

### SWITCH

DMOS output drivers with 0.75  $\Omega$  max push/pull capability. Non-overlap logic is provided to guarantee shoot through current is minimized.

### RESET

The  $\overline{\text{RESET}}$  is an open drain output which goes low when the feedback voltage on FB1 and FB2 goes below the undervoltage  $\overline{\text{RESET}}$  threshold. The output also goes low when the voltage on FB1 and FB2 exceeds the overvoltage  $\overline{\text{RESET}}$  threshold. The  $\overline{\text{RESET}}$  output is an open drain output capable of sinking 1.6 mA.

### FB1 and FB2

FB1 and FB2 are the feedback pins to the error amplifier, which control the output SWITCH as needed to the regulated output. They are internally wire bonded to the same electrical connection providing double protection for an open circuit which would cause the buck regulator to rise above its desired output reaching the voltage on  $V_{IN}$ . These pins also provide the feedback path for the  $\overline{\text{RESET}}$  function.

### DELAY

There are two options for the delay time for the  $\overline{\text{RESET}}$  to go low. Connecting the pin to GND will provide a minimum of 14 ms. Connecting the pin to FB1 and FB2 will provide a minimum of 28 ms. Absolute max voltage on the DELAY pin is 7.0 V. Use a resistor divider to run off higher voltages. The 7.5 V option will require this divider (see Figure 6).

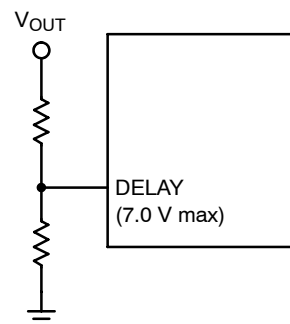

Figure 6.

### COMP

The COMP pin provides access to the error amplifiers output. Switching power supplies work as feedback control systems, and require compensation for stability. A 1.0 k resistor and 0.1  $\mu$ F capacitor work well in the application in Figure 2.

### CP

The on-chip DMOS drivers require the gates of the devices to be pulled above their drain voltage. An external capacitor located between the SWITCH output, and the CP pin provides the charge pump action to drive the gate of the high-side driver high enough to turn the device on.

APPLICATIONS INFORMATION

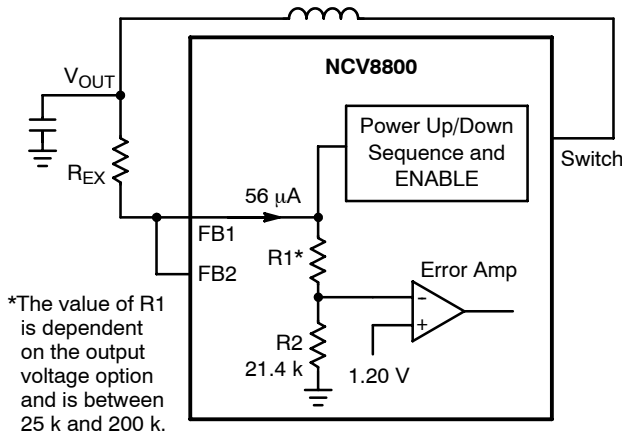

Figure 7.

\*The value of R1 is dependent on the output voltage option and is between 25 k and 200 k.

**Increasing the Output Voltage**

Adjustments to the output voltage can be made with an external resistor ( $R_{EX}$ ). The increase in output voltage will typically be  $56 \mu A \times R_{EX}$ . Caution and consideration must be given to the tracking feature and temperature coefficient and matching of internal and external resistors. Output tracking always follows the Feedback pins (FB1 and FB2). The typical temperature coefficient for R1 and R2 is +4600 ppm/°C.

**THEORY OF OPERATION**

**V<sup>2</sup> Control Method**

The V<sup>2</sup> method of control uses a ramp signal that is generated by the ESR of the output capacitors. This ramp is proportional to the AC current through the main inductor and is offset by the value of the DC output voltage. This control scheme inherently compensates for variations in either line or load conditions, since the ramp signal is generated from the output voltage itself. This control scheme differs from traditional techniques such as voltage mode, which generates an artificial ramp, and current mode, which generates a ramp from inductor current.

The V<sup>2</sup> control method is illustrated in Figure 8. The output voltage is used to generate both the error signal and the ramp signal. Since the ramp signal is simply the output voltage, it is affected by any change in the output regardless of the origin of the change. The ramp signal also contains the DC portion of the output voltage, which allows the control circuit to drive the main switch to 0% or 100% duty cycle as required.

A change in line voltage changes the current ramp in the inductor, affecting the ramp signal, which causes the V<sup>2</sup> control scheme to compensate the duty cycle. Since the change in the inductor current modifies the ramp signal, as in current mode control, the V<sup>2</sup> control scheme has the same advantages in line transient response.

A change in load current will have an effect on the output voltage, altering the ramp signal. A load step immediately changes the state of the comparator output, which controls the main switch. Load transient response is determined only by the comparator response time and the transition speed of the main switch. The reaction time to an output load step has no relation to the crossover frequency of the error signal loop, as in traditional control methods.

The error signal loop can have a low crossover frequency, since transient response is handled by the ramp signal loop. The main purpose of this “slow” feedback loop is to provide DC accuracy. Noise immunity is significantly improved, since the error amplifier bandwidth can be rolled off at a low frequency. Enhanced noise immunity improves remote sensing of the output voltage, since the noise associated with long feedback traces can be effectively filtered.

Line and load regulations are drastically improved because there are two independent voltage loops. A voltage mode controller relies on a change in the error signal to compensate for a derivation in either line or load voltage. This change in the error signal causes the output voltage to change corresponding to the gain of the error amplifier, which is normally specified as line and load regulation. A current mode controller maintains fixed error signal under deviation in the line voltage, since the slope of the ramp signal changes, but still relies on a change in the error signal for a deviation in load. The V<sup>2</sup> method of control maintains a fixed error signal for both line and load variations, since both line and load affect the ramp signal.

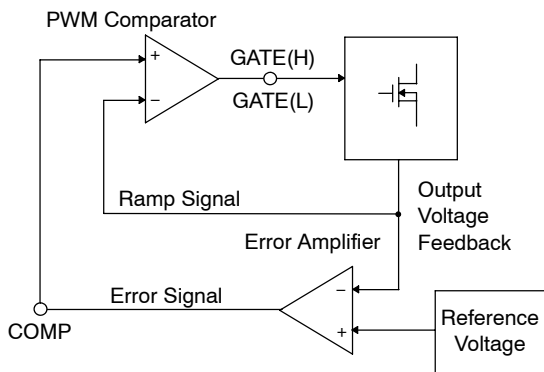

Figure 8. V<sup>2</sup> Control Block Diagram

**Constant Frequency Operation**

During normal operation, the oscillator generates a 200 kHz, 90% duty cycle waveform. The rising edge of this waveform determines the beginning of each switching cycle, at which point the high-side switch will be turned on. The high-side switch will be turned off when the ramp signal intersects the output of the error amplifier (COMP pin voltage). Therefore, the switch duty cycle can be modified to regulate the output voltage to the desired value as line and load conditions change.

## NCV8800 Series

The major advantage of constant frequency operation is that the component selections, especially the magnetic component design, become very easy. Oscillator frequency is fixed at 200 kHz.

### Start-Up

After the NCV8800 is powered up, the error amplifier will begin linearly charging the COMP pin capacitor. The COMP capacitance and the source current of the error amplifier determine the slew rate of COMP voltage. The output of the error amplifier is connected internally to the inverting input of the PWM comparator and it is compared with the divided down output voltage FB1/FB2 at the non-inverting input of the PWM comparator. At the beginning of each switching cycle, the oscillator output will set the PWM latch. This causes the high-side switch to turn on and the regulator output voltage to ramp up.

When the divided down output voltage achieves a level set by the COMP voltage, the high-side switch will be turned off. The  $V^2$  control loop will adjust the high-side switch duty cycle as required to ensure the regulator output voltage tracks the COMP voltage. Since the COMP voltage increases gradually, Soft Start can be achieved.

### Overcurrent Protection

The output switch is protected on both the high side and low side. Current limit is set at 1.0 A (min).

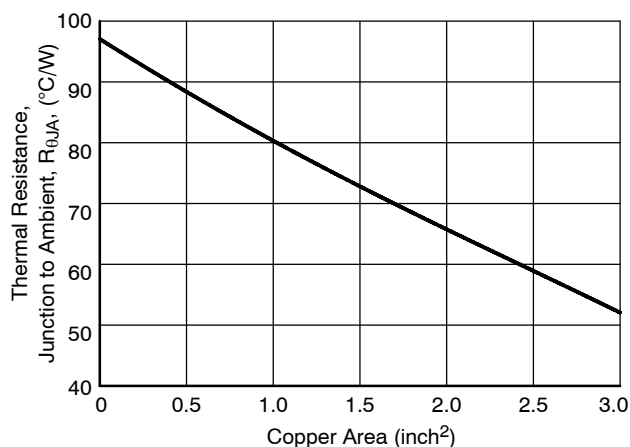

**Figure 9.16 Lead SOW (4 Leads Fused),  $\theta_{JA}$  as a Function of the Pad Copper Area (2 oz. Cu. Thickness), Board Material = 0.0625" G-10/R-4**

### Heat Sinks

A heat sink effectively increases the surface area of the package to improve the flow of heat away from the IC and into the surrounding air.

Each material in the heat flow path between the IC and the outside environment will have a thermal resistance. Like series electrical resistances, these resistances are summed to determine the value of  $R_{\theta JA}$ :

$$R_{\theta JA} = R_{\theta JC} + R_{\theta CS} + R_{\theta SA} \quad (3)$$

where:

$R_{\theta JC}$  = the junction-to-case thermal resistance,

$R_{\theta CS}$  = the case-to- heatsink thermal resistance, and

$R_{\theta SA}$  = the heatsink-to-ambient thermal resistance.

$R_{\theta JC}$  appears in the package section of the data sheet. Like  $R_{\theta JA}$ , it too is a function of package type.  $R_{\theta CS}$  and  $R_{\theta SA}$  are functions of the package type, heatsink and the interface between them. These values appear in heat sink data sheets of heat sink manufacturers.

## NCV8800 Series

### ORDERING INFORMATION

Device	Output Voltage	ENABLE Option	Package	Shipping†
NCV8800SDW26	2.6 V	Sequenced	SO-16L	46 Units/Rail
NCV8800SDW26R2				1000 Tape & Reel
NCV8800HDW26		High Voltage		46 Units/Rail
NCV8800HDW26R2				1000 Tape & Reel
NCV8800SDW33	3.3 V	Sequenced		46 Units/Rail
NCV8800SDW33R2				1000 Tape & Reel
NCV8800HDW33		High Voltage		46 Units/Rail
NCV8800HDW33R2				1000 Tape & Reel
NCV8800HDW50	5.0 V	High Voltage		46 Units/Rail
NCV8800HDW50R2				1000 Tape & Reel
NCV8800HDW75	7.5 V			46 Units/Rail
NCV8800HDW75R2				1000 Tape & Reel

†For information on tape and reel specifications, including part orientation and tape sizes, please refer to our Tape and Reel Packaging Specifications Brochure, BRD8011/D.

# MECHANICAL CASE OUTLINE PACKAGE DIMENSIONS

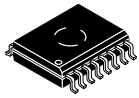

1  
SCALE 1:1

SOIC-16 WB  
CASE 751G  
ISSUE E

DATE 08 OCT 2021

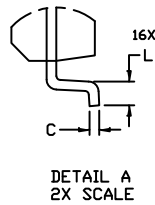
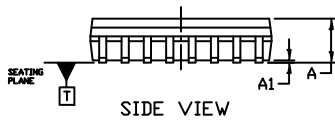
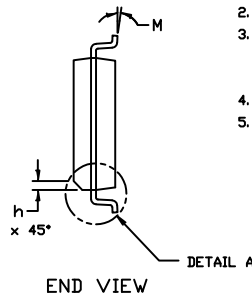
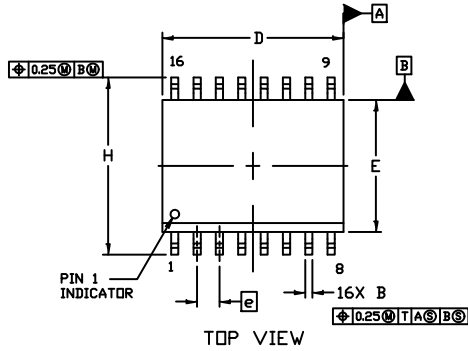

NOTES:

- DIMENSIONING AND TOLERANCING PER ASME Y14.5M, 1994.
- CONTROLLING DIMENSION: MILLIMETERS
- DIMENSION *b* DOES NOT INCLUDE DAMBAR PROTRUSION. ALLOWABLE PROTRUSION SHALL BE 0.13 TOTAL IN EXCESS OF *B* DIMENSION AT MAXIMUM MATERIAL CONDITION.
- DIMENSIONS *D* AND *E* DO NOT INCLUDE MOLD PROTRUSIONS.
- MAXIMUM MOLD PROTRUSION OR FLASH TO BE 0.15 PER SIDE.

DIM	MILLIMETERS	
	MIN.	MAX.
A	2.35	2.65
A1	0.10	0.25
B	0.35	0.49
C	0.23	0.32
D	10.15	10.45
E	7.40	7.60
e	1.27 BSC	
H	10.05	10.55
h	0.53 REF	
L	0.50	0.90
M	0°	7°

GENERIC MARKING DIAGRAM\*

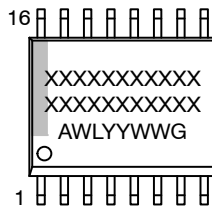

- XXXXX = Specific Device Code
- A = Assembly Location
- WL = Wafer Lot
- YY = Year
- WW = Work Week
- G = Pb-Free Package

\*This information is generic. Please refer to device data sheet for actual part marking. Pb-Free indicator, "G" or microdot "▪", may or may not be present. Some products may not follow the Generic Marking.

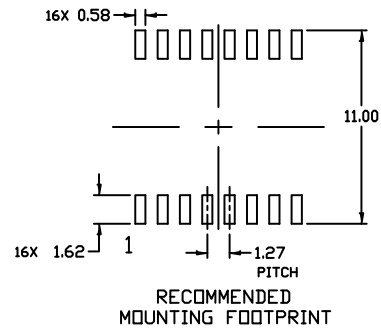

DOCUMENT NUMBER:	98ASB42567B	Electronic versions are uncontrolled except when accessed directly from the Document Repository. Printed versions are uncontrolled except when stamped "CONTROLLED COPY" in red.
DESCRIPTION:	SOIC-16 WB	PAGE 1 OF 1

onsemi and onSEMI are trademarks of Semiconductor Components Industries, LLC dba onsemi or its subsidiaries in the United States and/or other countries. onsemi reserves the right to make changes without further notice to any products herein. onsemi makes no warranty, representation or guarantee regarding the suitability of its products for any particular purpose, nor does onsemi assume any liability arising out of the application or use of any product or circuit, and specifically disclaims any and all liability, including without limitation special, consequential or incidental damages. onsemi does not convey any license under its patent rights nor the rights of others.

**onsemi**, **Onsemi**, and other names, marks, and brands are registered and/or common law trademarks of Semiconductor Components Industries, LLC dba "**onsemi**" or its affiliates and/or subsidiaries in the United States and/or other countries. **onsemi** owns the rights to a number of patents, trademarks, copyrights, trade secrets, and other intellectual property. A listing of **onsemi**'s product/patent coverage may be accessed at [www.onsemi.com/site/pdf/Patent-Marking.pdf](http://www.onsemi.com/site/pdf/Patent-Marking.pdf). **onsemi** reserves the right to make changes at any time to any products or information herein, without notice. The information herein is provided "as-is" and **onsemi** makes no warranty, representation or guarantee regarding the accuracy of the information, product features, availability, functionality, or suitability of its products for any particular purpose, nor does **onsemi** assume any liability arising out of the application or use of any product or circuit, and specifically disclaims any and all liability, including without limitation special, consequential or incidental damages. Buyer is responsible for its products and applications using **onsemi** products, including compliance with all laws, regulations and safety requirements or standards, regardless of any support or applications information provided by **onsemi**. "Typical" parameters which may be provided in **onsemi** data sheets and/or specifications can and do vary in different applications and actual performance may vary over time. All operating parameters, including "Typicals" must be validated for each customer application by customer's technical experts. **onsemi** does not convey any license under any of its intellectual property rights nor the rights of others. **onsemi** products are not designed, intended, or authorized for use as a critical component in life support systems or any FDA Class 3 medical devices or medical devices with a same or similar classification in a foreign jurisdiction or any devices intended for implantation in the human body. Should Buyer purchase or use **onsemi** products for any such unintended or unauthorized application, Buyer shall indemnify and hold **onsemi** and its officers, employees, subsidiaries, affiliates, and distributors harmless against all claims, costs, damages, and expenses, and reasonable attorney fees arising out of, directly or indirectly, any claim of personal injury or death associated with such unintended or unauthorized use, even if such claim alleges that **onsemi** was negligent regarding the design or manufacture of the part. **onsemi** is an Equal Opportunity/Affirmative Action Employer. This literature is subject to all applicable copyright laws and is not for resale in any manner.

## ADDITIONAL INFORMATION

### TECHNICAL PUBLICATIONS:

Technical Library: [www.onsemi.com/design/resources/technical-documentation](http://www.onsemi.com/design/resources/technical-documentation)  
onsemi Website: [www.onsemi.com](http://www.onsemi.com)

### ONLINE SUPPORT: [www.onsemi.com/support](http://www.onsemi.com/support)

For additional information, please contact your local Sales Representative at [www.onsemi.com/support/sales](http://www.onsemi.com/support/sales)

## Looking for pricing, stock, or lifecycle information?

Click below to explore more details on WIN SOURCE:

 [View NCV8800HDW75 on WIN SOURCE](#)

 [ON Semiconductor](#) Information

## Optimize Your Supply Chain with WIN SOURCE Solutions

-  Global Sourcing Solution
-  Obsolete Management
-  Cost Control Management
-  Shortage Management
-  Alternative Solution
-  Excess Inventory Management