



**THE DATASHEET OF
SN74GTL2003RKSR**



Table of Contents

1 Features	1	8.3 Feature Description	8
2 Applications	1	8.4 Device Functional Modes	9
3 Description	1	9 Application and Implementation	10
4 Revision History	2	9.1 Application Information	10
5 Pin Configuration and Functions	3	9.2 Typical Applications	10
6 Specifications	4	10 Power Supply Recommendations	14
6.1 Absolute Maximum Ratings	4	11 Layout	14
6.2 ESD Ratings	4	11.1 Layout Guidelines	14
6.3 Recommended Operating Conditions	4	11.2 Layout Example	15
6.4 Thermal Information	4	12 Device and Documentation Support	16
6.5 Electrical Characteristics	5	12.1 Receiving Notification of Documentation Updates	16
6.6 Switching Characteristics	5	12.2 Community Resources	16
6.7 Typical Characteristics	5	12.3 Trademarks	16
7 Parameter Measurement Information	6	12.4 Electrostatic Discharge Caution	16
8 Detailed Description	8	12.5 Glossary	16
8.1 Overview	8	13 Mechanical, Packaging, and Orderable Information	16
8.2 Functional Block Diagram	8		

4 Revision History

NOTE: Page numbers for previous revisions may differ from page numbers in the current version.

Changes from Revision B (June 2015) to Revision C	Page
• Updated <i>Features</i>	1
• Updated pinout images to new format	3
• Added <i>Receiving Notification of Documentation Updates</i> section	16

Changes from Revision A (March 2013) to Revision B	Page
• Added <i>ESD Ratings</i> table, <i>Feature Description</i> section, <i>Device Functional Modes</i> , <i>Application and Implementation</i> section, <i>Power Supply Recommendations</i> section, <i>Layout</i> section, <i>Device and Documentation Support</i> section, and <i>Mechanical, Packaging, and Orderable Information</i> section	1

5 Pin Configuration and Functions

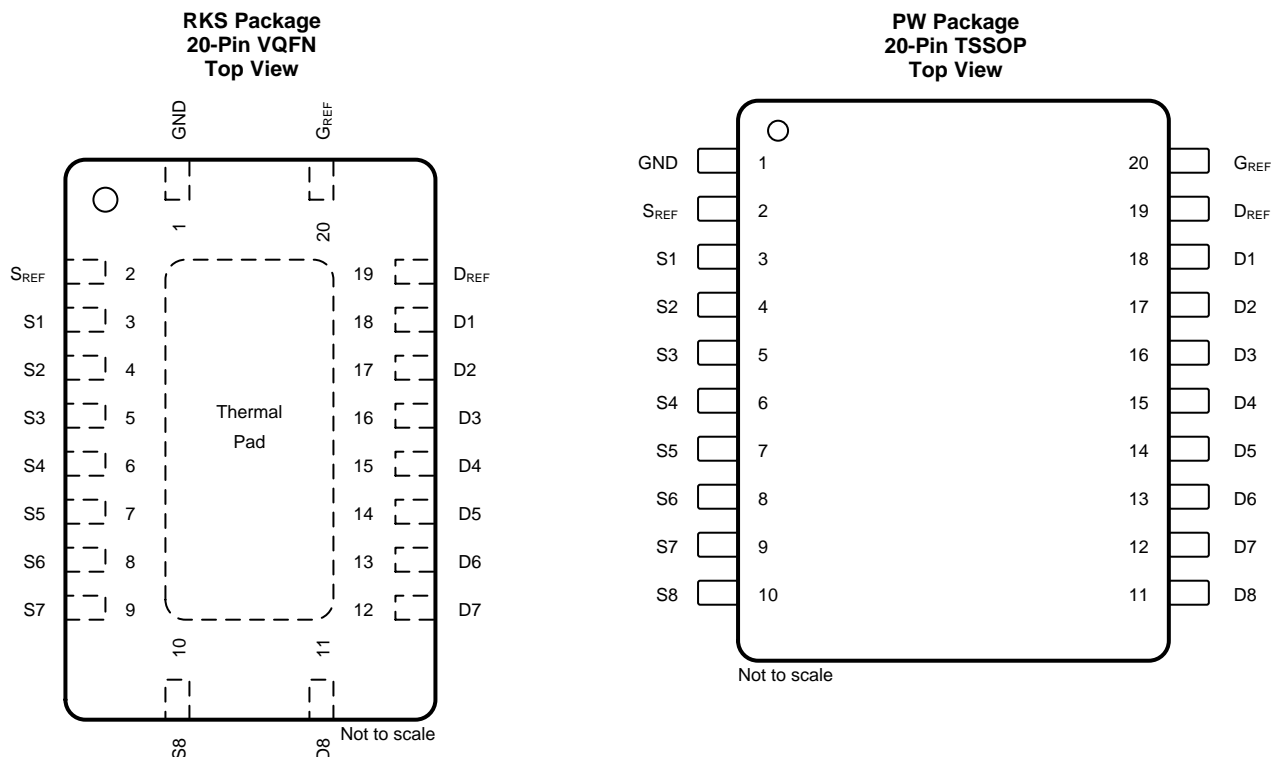

Pin Functions

PIN		I/O	DESCRIPTION
NAME	NO.		
D1	18	I/O	GTL drain port
D2	17	I/O	GTL drain port
D3	16	I/O	GTL drain port
D4	15	I/O	GTL drain port
D5	14	I/O	GTL drain port
D6	13	I/O	GTL drain port
D7	12	I/O	GTL drain port
D8	11	I/O	GTL drain port
D _{REF}	19	—	Drain of reference transistor, tie directly to G _{REF} and pull up to reference voltage through a 200-kΩ resistor
GND	1	—	Ground
G _{REF}	20	—	Gate of reference transistor, tie directly to D _{REF} and pull up to reference voltage through a 200-kΩ resistor
S1	3	I/O	LVTTTL/TTL source port
S2	4	I/O	LVTTTL/TTL source port
S3	5	I/O	LVTTTL/TTL source port
S4	6	I/O	LVTTTL/TTL source port
S5	7	I/O	LVTTTL/TTL source port
S6	8	I/O	LVTTTL/TTL source port
S7	9	I/O	LVTTTL/TTL source port
S8	10	I/O	LVTTTL/TTL source port
S _{REF}	2	—	Source of reference transistor

6 Specifications

6.1 Absolute Maximum Ratings

over operating free-air temperature range (unless otherwise noted)⁽¹⁾

		MIN	MAX	UNIT
V _{SREF}	DC source reference voltage	-0.5	7	V
V _{DREF}	DC drain reference voltage	-0.5	7	V
V _{GREF}	DC gate reference voltage	-0.5	7	V
V _{Sn}	DC voltage port Sn	-0.5	7	V
V _{Dn}	DC voltage port Dn	-0.5	7	V
I _{REFK}	DC diode current on reference pins	V _I < 0 V	-50	mA
I _{SK}	DC diode current port Sn	V _I < 0V	-50	mA
I _{DK}	DC diode current port Dn	V _I < 0 V	-50	mA
I _{MAX}	DC clamp current per channel	Channel is ON state	±128	mA
T _{stg}	Storage temperature	-65	150	°C

- (1) Stresses beyond those listed under *Absolute Maximum Ratings* may cause permanent damage to the device. These are stress ratings only, which do not imply functional operation of the device at these or any other conditions beyond those indicated under *Recommended Operating Conditions*. Exposure to absolute-maximum-rated conditions for extended periods may affect device reliability.

6.2 ESD Ratings

		VALUE	UNIT
V _(ESD)	Electrostatic discharge	Human body model (HBM), per ANSI/ESDA/JEDEC JS-001 ⁽¹⁾	±2000
		Charged-device model (CDM), per JEDEC specification JESD22-C101 ⁽²⁾	±1000

- (1) JEDEC document JEP155 states that 500-V HBM allows safe manufacturing with a standard ESD control process.
 (2) JEDEC document JEP157 states that 250-V CDM allows safe manufacturing with a standard ESD control process.

6.3 Recommended Operating Conditions

over operating free-air temperature range (unless otherwise noted)⁽¹⁾

		MIN	MAX	UNIT
V _{I/O}	Input/output voltage (Sn, Dn)	0	5.5	V
V _{SREF}	DC source reference voltage ⁽¹⁾	0	5.5	V
V _{DREF}	DC drain reference voltage	0	5.5	V
V _{GREF}	DC gate reference voltage	0	5.5	V
I _{PASS}	Pass transistor current		64	mA
T _A	Operating ambient temperature (in free air)	-40	85	°C

- (1) V_{SREF} = V_{DREF} – 1.5 V for best results in level-shifting applications.

6.4 Thermal Information

THERMAL METRIC ⁽¹⁾	SN74GTL2003		UNIT	
	PW (TSSOP)	RKS (VQFN)		
	20 PINS	20 PINS		
R _{θJA}	Junction-to-ambient thermal resistance	83	81	°C/W
R _{θJC(top)}	Junction-to-case (top) thermal resistance	32	36	°C/W

- (1) For more information about traditional and new thermal metrics, see the [Semiconductor and IC Package Thermal Metrics](#) application report.

6.5 Electrical Characteristics

over recommended operating free-air temperature range, $V_{CC} = 3.3 \text{ V} \pm 0.3 \text{ V}$ (unless otherwise noted)

PARAMETER		TEST CONDITIONS ⁽¹⁾		MIN	TYP ⁽¹⁾	MAX	UNIT	
V_{OL}	Low-level output voltage	$V_{DD} = 3 \text{ V}$, $V_{SREF} = 1.365 \text{ V}$, V_{Sn} or $V_{Dn} = 0.175 \text{ V}$, $I_{clamp} = 15.2 \text{ mA}$			260	350	mV	
V_{IK}	Input clamp voltage	$I_I = -18 \text{ mA}$	$V_{GREF} = 0 \text{ V}$			-1.2	V	
I_{IH}	Gate input leakage	$V_I = 5 \text{ V}$	$V_{GREF} = 0 \text{ V}$			5	μA	
$C_{I(GREF)}$	Gate capacitance	$V_I = 3 \text{ V}$ or 0 V			56		pF	
$C_{IO(OFF)}$	OFF capacitance	$V_O = 3 \text{ V}$ or 0 V	$V_{GREF} = 0 \text{ V}$		7.4		pF	
$C_{IO(ON)}$	ON capacitance	$V_O = 3 \text{ V}$ or 0 V	$V_{GREF} = 3 \text{ V}$		18.6		pF	
r_{on} ⁽²⁾	ON-state resistance	$V_I = 0 \text{ V}$	$V_{GREF} = 4.5 \text{ V}$	$I_O = 64 \text{ mA}$		3.5	5	Ω
			$V_{GREF} = 3 \text{ V}$			4.4	7	
			$V_{GREF} = 2.3 \text{ V}$			5.5	9	
			$V_{GREF} = 1.5 \text{ V}$			67	105	
		$V_I = 2.4 \text{ V}$	$V_{GREF} = 1.5 \text{ V}$	$I_O = 30 \text{ mA}$		9	15	
			$V_{GREF} = 4.5 \text{ V}$			7	10	
			$V_{GREF} = 3 \text{ V}$			58	80	
			$V_{GREF} = 2.3 \text{ V}$			50	70	

- (1) All typical values are measured at $T_A = 25^\circ\text{C}$.
- (2) Measured by the voltage drop between the Sn and the Dn terminals at the indicated current through the switch. ON-state resistance is determined by the lowest voltage of the two (Sn or Dn) terminals.

6.6 Switching Characteristics

$V_{REF} = 1.365 \text{ V}$ to 1.635 V , $V_{DD1} = 3 \text{ V}$ to 3.6 V , $V_{DD2} = 2.36 \text{ V}$ to 2.64 V , $GND = 0 \text{ V}$, $t_r = t_f \leq 3 \text{ ns}$, $T_A = -40^\circ\text{C}$ to $+85^\circ\text{C}$ (see Figure 6)⁽¹⁾

PARAMETER		MIN	TYP ⁽²⁾	MAX	UNIT
t_{PLH} ⁽³⁾	Propagation delay (Sn to Dn, Dn to Sn)	0.5	1.5	5.5	ns
t_{PD}	Propagation delay ⁽⁴⁾			250	ps

- (1) $C_{ON(max)}$ of 30 pF and a $C_{OFF(max)}$ of 15 pF is specified by design.
- (2) All typical values are measured at $V_{DD1} = 3.3 \text{ V}$, $V_{DD2} = 2.5 \text{ V}$, $V_{REF} = 1.5 \text{ V}$ and $T_A = 25^\circ\text{C}$.
- (3) Propagation delay specified by characterization.
- (4) This parameter is warranted but not production tested. The propagation delay is based on the RC time constant of the typical ON-state resistance of the switch and a load capacitance of 50 pF, when driven by an ideal voltage source (zero output impedance).

6.7 Typical Characteristics

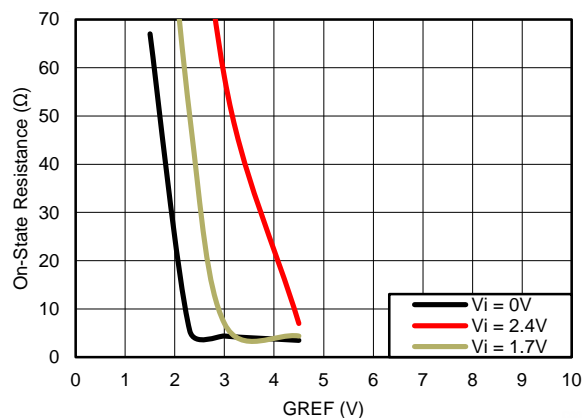

Figure 1. ON-Resistance vs G_{REF} Typical Curves

7 Parameter Measurement Information

C_L = Load Capacitance, includes jig and probe capacitance (see [Electrical Characteristics](#) for value)

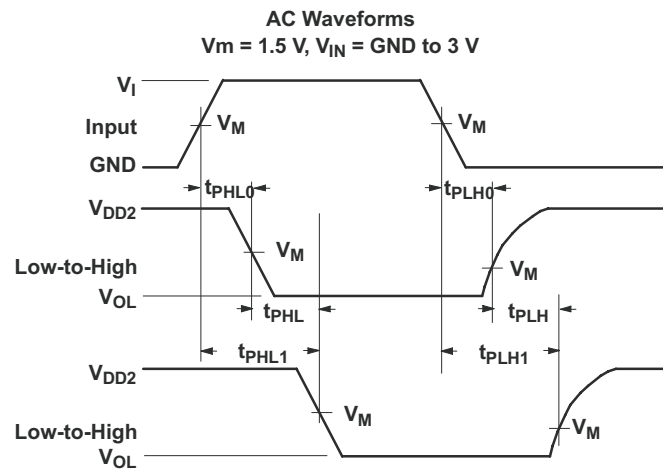

Figure 2. Input (Sn) to Output (Dn) Propagation Delays

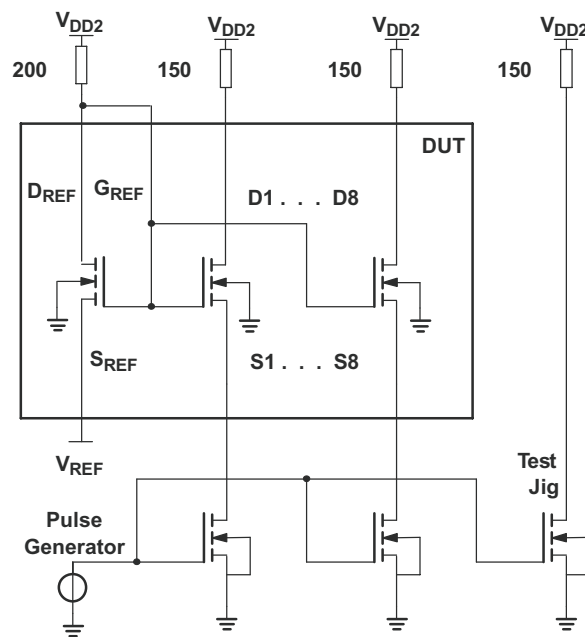

Figure 3. Load Circuit

Parameter Measurement Information (continued)

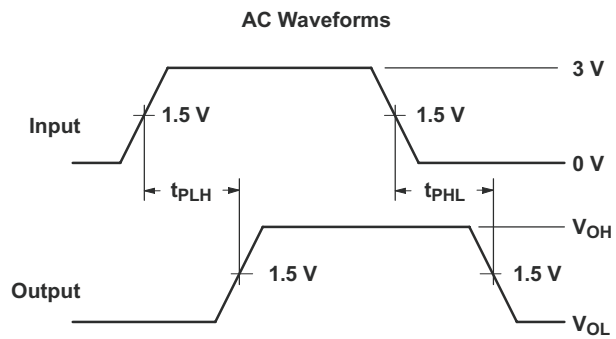

Figure 4. Input (S_n) to Output (D_n) Propagation Delays

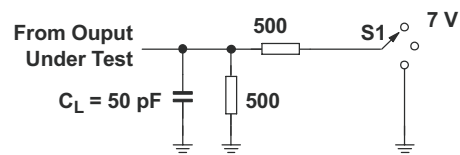

Figure 5. Load Circuit

Table 1. Test Conditions

TEST	S1
t_{pd}	Open
t_{PLZ}/t_{PZL}	7 V
T_{PHZ}/T_{PZH}	Open

8 Detailed Description

8.1 Overview

The SN74GTL2003 device provides eight NMOS pass transistors (S_n and D_n) with a common gate (G_{REF}) and a reference transistor (S_{REF} and D_{REF}). The low ON-state resistance of the switch allows connections to be made with minimal propagation delay. With no direction control pin required, the device allows bidirectional voltage translations any voltage (0.95 V to 5 V) to any voltage (0.95 V to 5 V).

When the S_n or D_n port is LOW, the clamp is in the ON state and a low-resistance connection exists between the S_n and D_n ports. Assuming the higher voltage is on the D_n port, when the D_n port is HIGH, the voltage on the S_n port is limited to the voltage set by the reference transistor (S_{REF}). When the S_n port is HIGH, the D_n port is pulled to VCC by the pullup resistors.

8.2 Functional Block Diagram

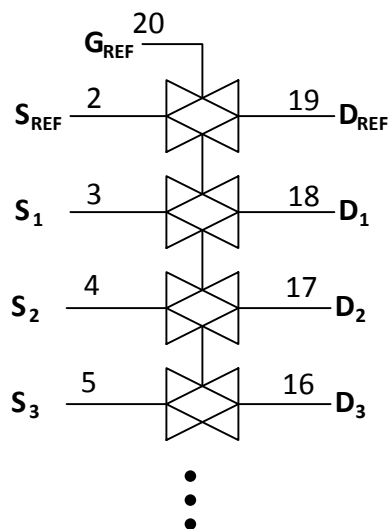

8.3 Feature Description

8.3.1 Provides Bidirectional Voltage Translation With No Direction Control Required

Because the circuit acts essentially as a pass transistor, no direction pin is needed, as data is allowed to flow both ways.

8.3.2 Flow Through Pinout

Allocated pins for input and output A on right side and input and output B on left side. Reduces the need for multi-layer board layout or long traces through system.

8.4 Device Functional Modes

**Table 2. High to Low Translation
(Assuming Dn is at the Higher Voltage Level)⁽¹⁾**

G_{REF}⁽²⁾	D_{REF}	S_{REF}	INPUTS D8–D1	OUTPUT S8–S1	TRANSISTOR
H	H	0 V	X	X	Off
H		V _{TT} ⁽³⁾	H	V _{TT} ⁽⁴⁾	On
H		V _{TT}	L	L ⁽⁵⁾	On
L	L	0 – V _{TT}	X	X	Off

- (1) H = HIGH voltage level, L = LOW voltage level, X = don't care.
- (2) G_{REF} should be at least 1.5 V higher than S_{REF} for best translator operation.
- (3) V_{TT} is equal to the S_{REF} voltage.
- (4) Sn is not pulled up or pulled down.
- (5) Sn follows the Dn input LOW.

**Table 3. Low to High Translation
(Assuming Dn is at the Higher Voltage Level)⁽¹⁾**

G_{REF}⁽²⁾	D_{REF}	S_{REF}	INPUTS D8–D1	OUTPUT S8–S1	TRANSISTOR
H	H	0 V	X	X	Off
H	H	V _{TT} ⁽³⁾	V _{TT}	H ⁽⁴⁾	Nearly Off
H	H	V _{TT}	L	L ⁽⁵⁾	On
L	L	0 – V _{TT}	X	X	Off

- (1) H = HIGH voltage level, L = LOW voltage level, X = don't care.
- (2) G_{REF} should be at least 1.5 V higher than S_{REF} for best translator operation.
- (3) V_{TT} is equal to the S_{REF} voltage.
- (4) Dn is pulled up to VCC through an external resistor.
- (5) Dn follows the Sn input LOW.

9 Application and Implementation

NOTE

Information in the following applications sections is not part of the TI component specification, and TI does not warrant its accuracy or completeness. TI's customers are responsible for determining suitability of components for their purposes. Customers should validate and test their design implementation to confirm system functionality.

9.1 Application Information

SN74GTL2003 is a GTL/GTL+ to LVTTTL/TTL bidirectional voltage level translator. This device can be used in both unidirectional applications and bidirectional. Please find the reference schematics and recommended values for passive components in the [Typical Applications](#).

9.2 Typical Applications

9.2.1 Bidirectional Translation

For the bidirectional clamping configuration (higher voltage to lower voltage or lower voltage to higher voltage), the G_{REF} input must be connected to D_{REF} and both pins pulled to HIGH-side V_{CC} through a pullup resistor (typically 200 k Ω). TI recommends a filter capacitor on D_{REF} . The processor output can be totem pole or open drain (pullup resistors) and the chipset output can be totem pole or open drain (pullup resistors are required to pull the Dn outputs to V_{CC}). However, if either output is totem pole, data must be unidirectional or the outputs must be 3-statable, and the outputs must be controlled by some direction-control mechanism to prevent HIGH-to-LOW contentions in either direction. If both outputs are open drain, no direction control is needed. The opposite side of the reference transistor (S_{REF}) is connected to the processor core power-supply voltage. When D_{REF} is connected through a 200-k Ω resistor to a 3.3-V to 5.5-V VCC supply and S_{REF} is set from 1 V to V_{CC} 1.5 V, the output of each Sn has a maximum output voltage equal to S_{REF} , and the output of each Dn has a maximum output voltage equal to V_{CC} .

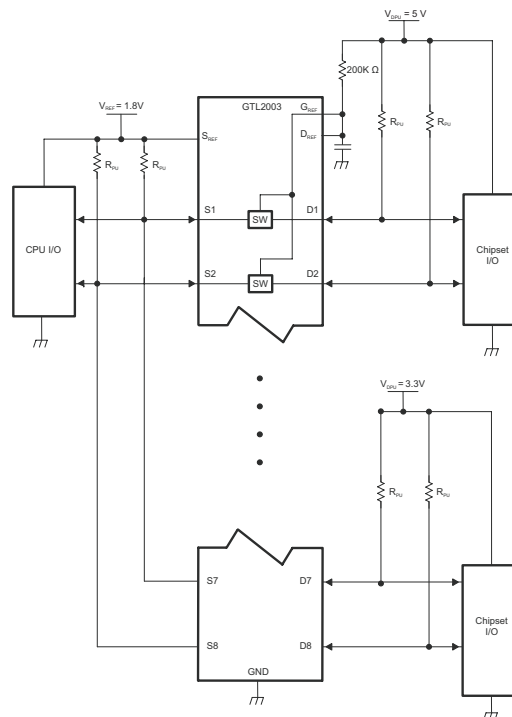

Figure 6. Bidirectional Translation to Multiple Higher Voltage Levels (Such as an I²C or SMBus Applications)

Typical Applications (continued)

9.2.1.1 Design Requirements

- SN74GTL2003 requires industry standard GTL and LVTTTL/TTL voltage levels.
- Place pullup resistors of ~200kΩ in all inputs/outputs to the GTL/TTL voltage levels.
- Place 0.1-μF bypass capacitors close to the power supply pins to reduce errors coupling in from noisy or high-impedance power supplies.
- Comply to the parameters in the [Recommended Operating Conditions](#).

9.2.1.2 Detailed Design Procedure

9.2.1.2.1 Sizing Pullup Resistors

The pullup resistor value should limit the current through the pass transistor when it is in the on state to about 15 mA. This ensures a pass voltage of 260 mV to 350 mV. If the current through the pass transistor is higher than 15 mA, the pass voltage also is higher in the on state. To set the current through each pass transistor at 15 mA, the pullup resistor value is calculated as:

$$\text{Resistor value } (\Omega) = \frac{\text{Pullup voltage (V)} - 0.35 \text{ V}}{0.015 \text{ A}} \quad (1)$$

Table 4 shows resistor values for various reference voltages and currents at 15 mA, 10 mA, and 3 mA. The resistor value shown in the +10% column, or a larger value, should be used to ensure that the pass voltage of the transistor would be 350 mV or less. The external driver must be able to sink the total current from the resistors on both sides of the GTL device at 0.175 V, although the 15 mA only applies to current flowing through the SN74GTL2003.

Table 4. Pullup Resistor Values⁽¹⁾⁽²⁾⁽³⁾

VOLTAGE	PULLUP RESISTOR VALUE (Ω)					
	15 mA		10 mA		3 mA	
	NOMINAL	+10%	NOMINAL	+10%	NOMINAL	+10%
5.0 V	310	341	465	512	1550	1705
3.3 V	197	217	295	325	983	1082
2.5 V	143	158	215	237	717	788
1.8 V	97	106	145	160	483	532
1.5 V	77	85	115	127	383	422
1.2 V	57	63	85	94	283	312

- (1) Calculated for $V_{OL} = 0.35 \text{ V}$
 (2) Assumes output driver $V_{OL} = 0.175 \text{ V}$ at stated current
 (3) +10% to compensate for V_{DD} range and resistor tolerance

9.2.1.3 Application Curve

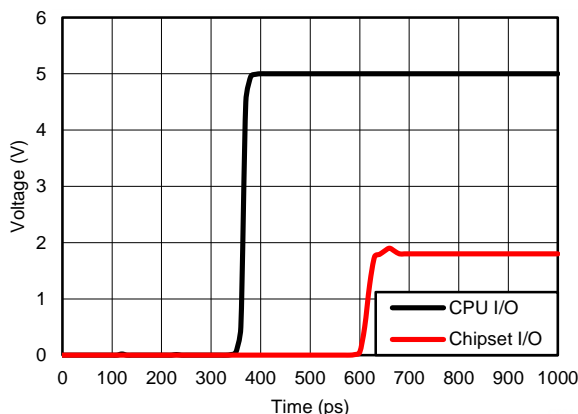

Figure 7. Signal Voltage vs Time (ps) (Simulated Design Results)

9.2.2 Unidirectional Down Translation

For unidirectional clamping (higher voltage to lower voltage), the G_{REF} input must be connected to D_{REF} and both pins pulled to the higher-side V_{CC} through a pullup resistor (typically 200 k Ω). TI recommends a filter capacitor on D_{REF} . Pullup resistors are required if the chipset I/Os are open drain. The opposite side of the reference transistor (S_{REF}) is connected to the processor core power supply voltage. When D_{REF} is connected through a 200-k Ω resistor to a 3.3-V to 5.5-V V_{CC} supply and S_{REF} is set from 1 V to $V_{CC} - 1.5$ V, the output of each S_n has a maximum output voltage equal to S_{REF} .

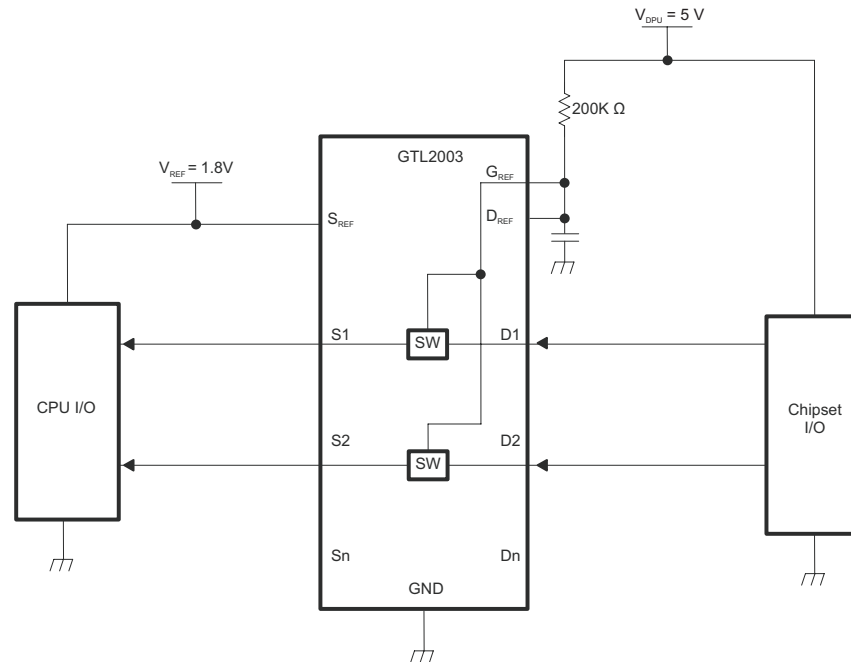

Figure 8. Unidirectional Down Translation to Protect Low-Voltage Processor Pins

9.2.2.1 Design Requirements

- SN74GTL2003 requires industry standard GTL and LVTTTL/TTL voltage levels.
- Place pullup resistors of approximately 200 k Ω in all inputs/outputs to the GTL/TTL voltage levels.
- Place 0.1- μ F bypass capacitors close to the power supply pins to reduce errors coupling in from noisy or high-impedance power supplies.
- Comply to the parameters in the [Recommended Operating Conditions](#).

9.2.2.2 Detailed Design Procedure

9.2.2.2.1 Sizing Pullup Resistors

The pullup resistor value should limit the current through the pass transistor when it is in the on state to about 15 mA. This ensures a pass voltage of 260 mV to 350 mV. If the current through the pass transistor is higher than 15 mA, the pass voltage also is higher in the on state. To set the current through each pass transistor at 15 mA, the pullup resistor value is calculated as:

$$\text{Resistor value}(\Omega) = \frac{\text{Pullup voltage}(V) - 0.35 V}{0.015 A} \quad (2)$$

[Table 5](#) shows resistor values for various reference voltages and currents at 15 mA, 10 mA, and 3 mA. The resistor value shown in the +10% column, or a larger value, should be used to ensure that the pass voltage of the transistor would be 350 mV or less. The external driver must be able to sink the total current from the resistors on both sides of the GTL device at 0.175 V, although the 15 mA only applies to current flowing through the SN74GTL2003.

Table 5. Pullup Resistor Values⁽¹⁾⁽²⁾⁽³⁾

VOLTAGE	PULLUP RESISTOR VALUE (Ω)					
	15 mA		10 mA		3 mA	
	NOMINAL	+10%	NOMINAL	+10%	NOMINAL	+10%
5.0 V	310	341	465	512	1550	1705
3.3 V	197	217	295	325	983	1082
2.5 V	143	158	215	237	717	788
1.8 V	97	106	145	160	483	532
1.5 V	77	85	115	127	383	422
1.2 V	57	63	85	94	283	312

- (1) Calculated for $V_{OL} = 0.35\text{ V}$
- (2) Assumes output driver $V_{OL} = 0.175\text{ V}$ at stated current
- (3) +10% to compensate for V_{DD} range and resistor tolerance

9.2.3 Unidirectional Up Translation

For unidirectional up translation (lower voltage to higher voltage), the reference transistor is connected the same as for a down translation. A pullup resistor is required on the higher voltage side (Dn or Sn) to get the full HIGH level, because the GTL device only passes the reference source (S_{REF}) voltage as a HIGH when doing an up translation. The driver on the lower voltage side only needs pullup resistors if it is open drain.

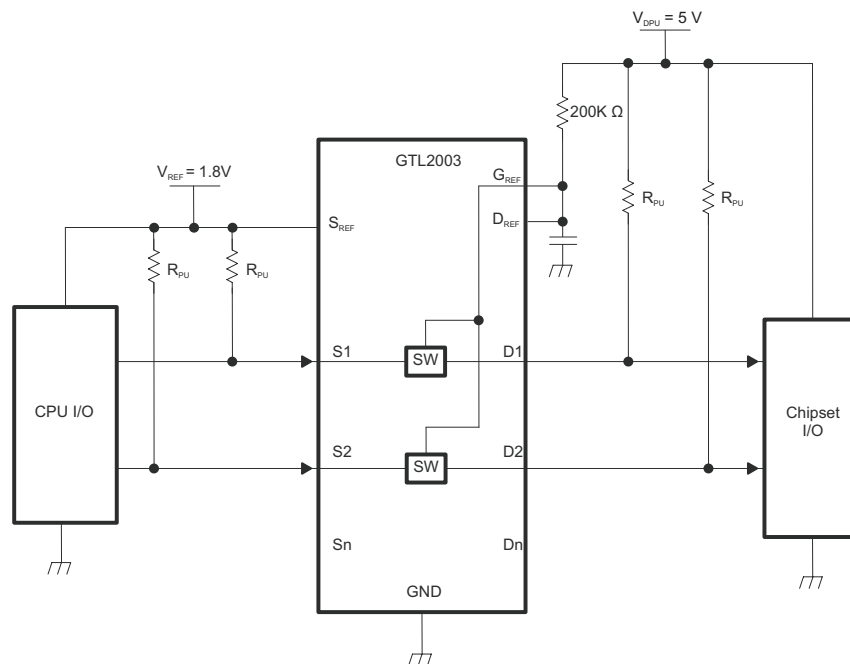

Figure 9. Unidirectional Up Translation to Higher-Voltage Chipsets

9.2.3.1 Design Requirements

- SN74GTL2003 requires industry standard GTL and LVTTTL/TTL voltage levels.
- Place pullup resistors of ~200kΩ in all inputs/outputs to the GTL/TTL voltage levels.
- Place 0.1-μF bypass capacitors close to the power supply pins to reduce errors coupling in from noisy or high-impedance power supplies.
- Comply to the parameters in the [Recommended Operating Conditions](#)

9.2.3.2 Detailed Design Procedure

9.2.3.2.1 Sizing Pullup Resistors

The pullup resistor value should limit the current through the pass transistor when it is in the on state to about 15 mA. This ensures a pass voltage of 260 mV to 350 mV. If the current through the pass transistor is higher than 15 mA, the pass voltage also is higher in the on state. To set the current through each pass transistor at 15 mA, the pullup resistor value is calculated as:

$$\text{Resistor value } (\Omega) = \frac{\text{Pullup voltage (V)} - 0.35 \text{ V}}{0.015 \text{ A}} \quad (3)$$

Table 6 shows resistor values for various reference voltages and currents at 15 mA, 10 mA, and 3 mA. The resistor value shown in the +10% column, or a larger value, should be used to ensure that the pass voltage of the transistor would be 350 mV or less. The external driver must be able to sink the total current from the resistors on both sides of the GTL device at 0.175 V, although the 15 mA only applies to current flowing through the SN74GTL2003.

Table 6. Pullup Resistor Values⁽¹⁾⁽²⁾⁽³⁾

PULLUP RESISTOR VALUE (Ω)						
VOLTAGE	15 mA		10 mA		3 mA	
	NOMINAL	+10%	NOMINAL	+10%	NOMINAL	+10%
5.0 V	310	341	465	512	1550	1705
3.3 V	197	217	295	325	983	1082
2.5 V	143	158	215	237	717	788
1.8 V	97	106	145	160	483	532
1.5 V	77	85	115	127	383	422
1.2 V	57	63	85	94	283	312

(1) Calculated for $V_{OL} = 0.35 \text{ V}$

(2) Assumes output driver $V_{OL} = 0.175 \text{ V}$ at stated current

(3) +10% to compensate for V_{DD} range and resistor tolerance

10 Power Supply Recommendations

Place 0.1- μF bypass capacitors close to the power supply pins to reduce errors coupling in from noisy or high-impedance power supplies.

11 Layout

11.1 Layout Guidelines

For best operational performance of the device, use good PCB layout practices, including:

- Noise can propagate into analog circuitry through the power pins of the circuit as a whole, as well as the operational amplifier. Bypass capacitors are used to reduce the coupled noise by providing low impedance power sources local to the analog circuitry.
 - Connect low-ESR, 0.1- μF ceramic bypass capacitors between each supply pin and ground, placed as close to the device as possible. A single bypass capacitor from $V+$ to ground is applicable for single supply applications.
- Separate grounding for analog and digital portions of circuitry is one of the simplest and most-effective methods of noise suppression. One or more layers on multilayer PCBs are usually devoted to ground planes. A ground plane helps distribute heat and reduces EMI noise pickup. Make sure to physically separate digital and analog grounds, paying attention to the flow of the ground current.
- To reduce parasitic coupling, run the input traces as far away from the supply or output traces as possible. If it is not possible to keep them separate, it is much better to cross the sensitive trace perpendicular as opposed to in parallel with the noisy trace.
- Place the external components as close to the device as possible. Keeping RF and RG close to the inverting input minimizes parasitic capacitance.

Layout Guidelines (continued)

- Keep the length of input traces as short as possible. Always remember that the input traces are the most sensitive part of the circuit.
- Consider a driven, low-impedance guard ring around the critical traces. A guard ring can significantly reduce leakage currents from nearby traces that are at different potentials.

11.2 Layout Example

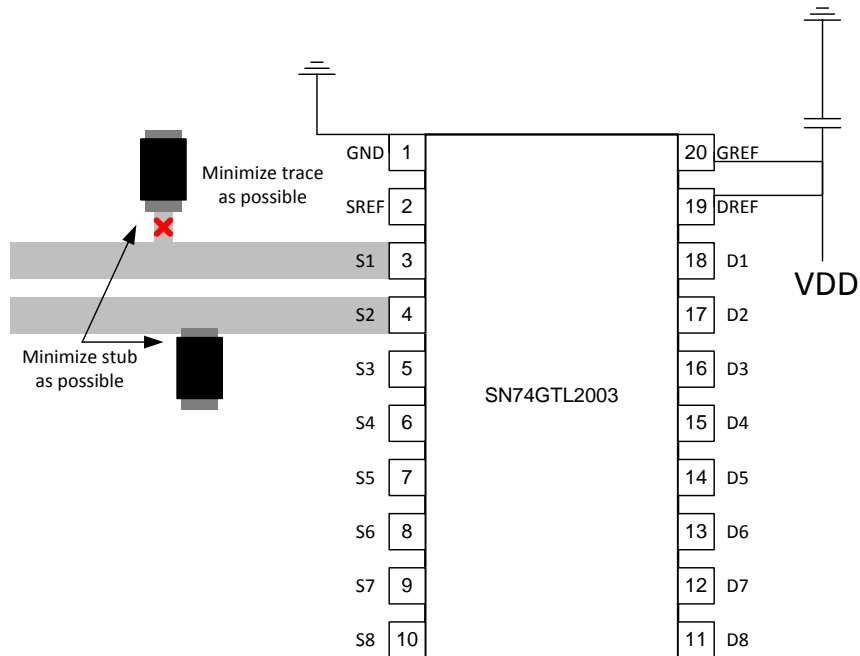

Figure 10. Layout Example for GTL Trace

12 Device and Documentation Support

12.1 Receiving Notification of Documentation Updates

To receive notification of documentation updates, navigate to the device product folder on ti.com. In the upper right corner, click on *Alert me* to register and receive a weekly digest of any product information that has changed. For change details, review the revision history included in any revised document.

12.2 Community Resources

The following links connect to TI community resources. Linked contents are provided "AS IS" by the respective contributors. They do not constitute TI specifications and do not necessarily reflect TI's views; see TI's [Terms of Use](#).

TI E2E™ Online Community *TI's Engineer-to-Engineer (E2E) Community*. Created to foster collaboration among engineers. At e2e.ti.com, you can ask questions, share knowledge, explore ideas and help solve problems with fellow engineers.

Design Support *TI's Design Support* Quickly find helpful E2E forums along with design support tools and contact information for technical support.

12.3 Trademarks

E2E is a trademark of Texas Instruments.
All other trademarks are the property of their respective owners.

12.4 Electrostatic Discharge Caution



These devices have limited built-in ESD protection. The leads should be shorted together or the device placed in conductive foam during storage or handling to prevent electrostatic damage to the MOS gates.

12.5 Glossary

[SLYZ022](#) — *TI Glossary*.

This glossary lists and explains terms, acronyms, and definitions.

13 Mechanical, Packaging, and Orderable Information

The following pages include mechanical, packaging, and orderable information. This information is the most current data available for the designated devices. This data is subject to change without notice and revision of this document. For browser-based versions of this data sheet, refer to the left-hand navigation.

PACKAGING INFORMATION

Orderable Device	Status (1)	Package Type	Package Drawing	Pins	Package Qty	Eco Plan (2)	Lead/Ball Finish (6)	MSL Peak Temp (3)	Op Temp (°C)	Device Marking (4/5)	Samples
SN74GTL2003PW	ACTIVE	TSSOP	PW	20	70	Green (RoHS & no Sb/Br)	CU NIPDAU	Level-1-260C-UNLIM	-40 to 85	GK2003	Samples
SN74GTL2003PWR	ACTIVE	TSSOP	PW	20	2000	Green (RoHS & no Sb/Br)	CU NIPDAU	Level-1-260C-UNLIM	-40 to 85	GK2003	Samples
SN74GTL2003RKS	ACTIVE	VQFN	RKS	20	3000	Green (RoHS & no Sb/Br)	CU NIPDAU	Level-1-260C-UNLIM	-40 to 85	GK2003	Samples

(1) The marketing status values are defined as follows:

ACTIVE: Product device recommended for new designs.

LIFEBUY: TI has announced that the device will be discontinued, and a lifetime-buy period is in effect.

NRND: Not recommended for new designs. Device is in production to support existing customers, but TI does not recommend using this part in a new design.

PREVIEW: Device has been announced but is not in production. Samples may or may not be available.

OBSOLETE: TI has discontinued the production of the device.

(2) Eco Plan - The planned eco-friendly classification: Pb-Free (RoHS), Pb-Free (RoHS Exempt), or Green (RoHS & no Sb/Br) - please check <http://www.ti.com/productcontent> for the latest availability information and additional product content details.

TBD: The Pb-Free/Green conversion plan has not been defined.

Pb-Free (RoHS): TI's terms "Lead-Free" or "Pb-Free" mean semiconductor products that are compatible with the current RoHS requirements for all 6 substances, including the requirement that lead not exceed 0.1% by weight in homogeneous materials. Where designed to be soldered at high temperatures, TI Pb-Free products are suitable for use in specified lead-free processes.

Pb-Free (RoHS Exempt): This component has a RoHS exemption for either 1) lead-based flip-chip solder bumps used between the die and package, or 2) lead-based die adhesive used between the die and leadframe. The component is otherwise considered Pb-Free (RoHS compatible) as defined above.

Green (RoHS & no Sb/Br): TI defines "Green" to mean Pb-Free (RoHS compatible), and free of Bromine (Br) and Antimony (Sb) based flame retardants (Br or Sb do not exceed 0.1% by weight in homogeneous material)

(3) MSL, Peak Temp. - The Moisture Sensitivity Level rating according to the JEDEC industry standard classifications, and peak solder temperature.

(4) There may be additional marking, which relates to the logo, the lot trace code information, or the environmental category on the device.

(5) Multiple Device Markings will be inside parentheses. Only one Device Marking contained in parentheses and separated by a "~" will appear on a device. If a line is indented then it is a continuation of the previous line and the two combined represent the entire Device Marking for that device.

(6) Lead/Ball Finish - Orderable Devices may have multiple material finish options. Finish options are separated by a vertical ruled line. Lead/Ball Finish values may wrap to two lines if the finish value exceeds the maximum column width.

Important Information and Disclaimer: The information provided on this page represents TI's knowledge and belief as of the date that it is provided. TI bases its knowledge and belief on information provided by third parties, and makes no representation or warranty as to the accuracy of such information. Efforts are underway to better integrate information from third parties. TI has taken and

continues to take reasonable steps to provide representative and accurate information but may not have conducted destructive testing or chemical analysis on incoming materials and chemicals. TI and TI suppliers consider certain information to be proprietary, and thus CAS numbers and other limited information may not be available for release.

In no event shall TI's liability arising out of such information exceed the total purchase price of the TI part(s) at issue in this document sold by TI to Customer on an annual basis.

TAPE AND REEL INFORMATION



QUADRANT ASSIGNMENTS FOR PIN 1 ORIENTATION IN TAPE



*All dimensions are nominal

Device	Package Type	Package Drawing	Pins	SPQ	Reel Diameter (mm)	Reel Width W1 (mm)	A0 (mm)	B0 (mm)	K0 (mm)	P1 (mm)	W (mm)	Pin1 Quadrant
SN74GTL2003RKSR	VQFN	RKS	20	3000	177.8	12.4	2.73	4.85	1.03	4.0	12.0	Q1

TAPE AND REEL BOX DIMENSIONS



*All dimensions are nominal

Device	Package Type	Package Drawing	Pins	SPQ	Length (mm)	Width (mm)	Height (mm)
SN74GTL2003RKSR	VQFN	RKS	20	3000	202.0	201.0	28.0

PW (R-PDSO-G20)

PLASTIC SMALL OUTLINE



- NOTES:
- A. All linear dimensions are in millimeters.
 - B. This drawing is subject to change without notice.
 - C. Publication IPC-7351 is recommended for alternate design.
 - D. Laser cutting apertures with trapezoidal walls and also rounding corners will offer better paste release. Customers should contact their board assembly site for stencil design recommendations. Refer to IPC-7525 for other stencil recommendations.
 - E. Customers should contact their board fabrication site for solder mask tolerances between and around signal pads.

RKS (R-PVQFN-N20)

PLASTIC QUAD FLATPACK NO-LEAD

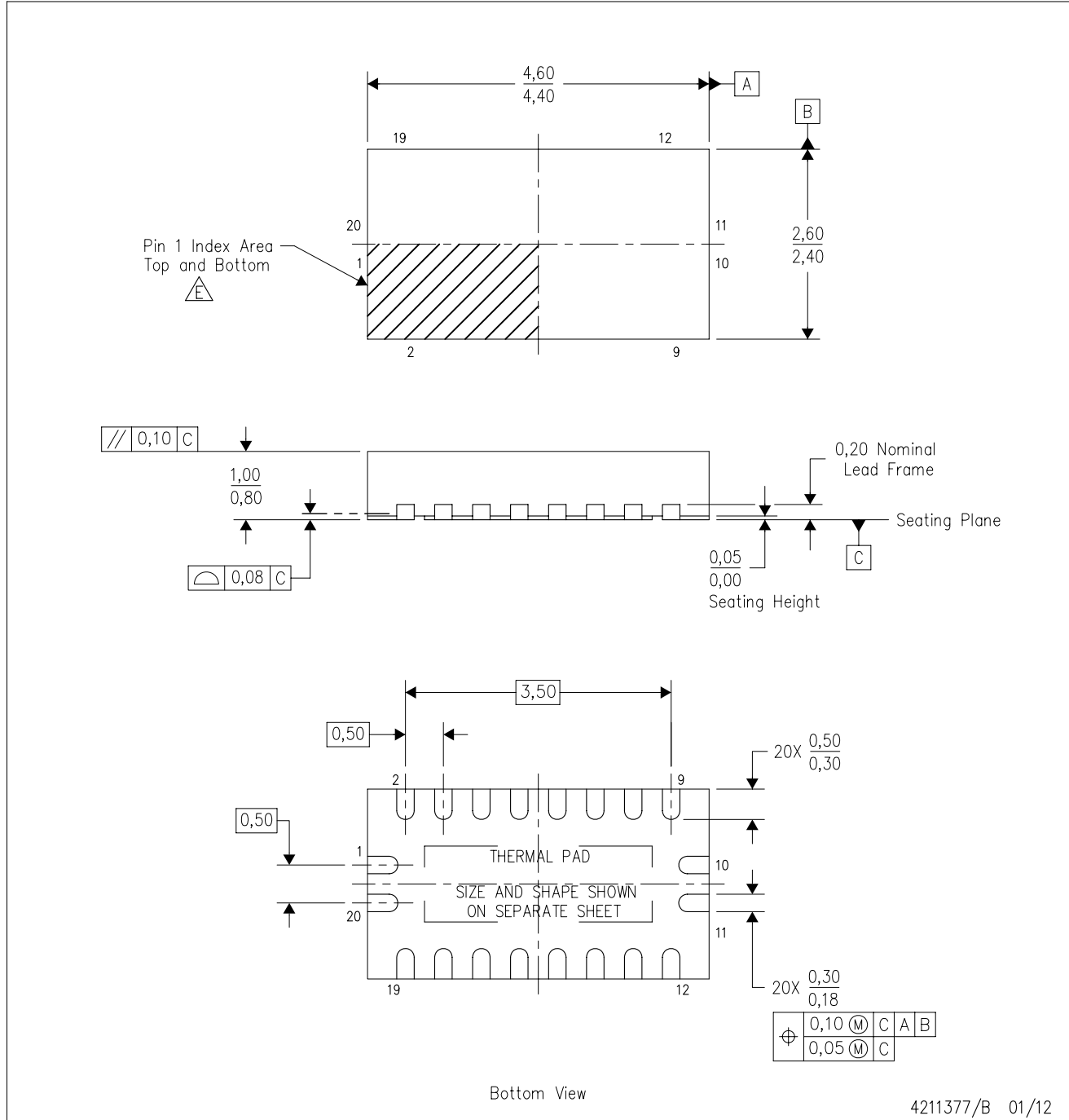

- NOTES:
- A. All linear dimensions are in millimeters. Dimensioning and tolerancing per ASME Y14.5M-1994.
 - B. This drawing is subject to change without notice.
 - C. QFN (Quad Flatpack No-Lead) package configuration.
 - D. The package thermal pad must be soldered to the board for thermal and mechanical performance.
 - E. See the additional figure in the Product Data Sheet for details regarding the exposed thermal pad features and dimensions.
- △ Pin 1 identifiers are located on both top and bottom of the package and within the zone indicated. The Pin 1 identifiers are either a molded, marked, or metal feature.

THERMAL PAD MECHANICAL DATA

RKS (R-PVQFN-N20)

PLASTIC QUAD FLATPACK NO-LEAD

THERMAL INFORMATION

This package incorporates an exposed thermal pad that is designed to be attached directly to an external heatsink. The thermal pad must be soldered directly to the printed circuit board (PCB). After soldering, the PCB can be used as a heatsink. In addition, through the use of thermal vias, the thermal pad can be attached directly to the appropriate copper plane shown in the electrical schematic for the device, or alternatively, can be attached to a special heatsink structure designed into the PCB. This design optimizes the heat transfer from the integrated circuit (IC).

For information on the Quad Flatpack No-Lead (QFN) package and its advantages, refer to Application Report, QFN/SON PCB Attachment, Texas Instruments Literature No. SLUA271. This document is available at www.ti.com.

The exposed thermal pad dimensions for this package are shown in the following illustration.

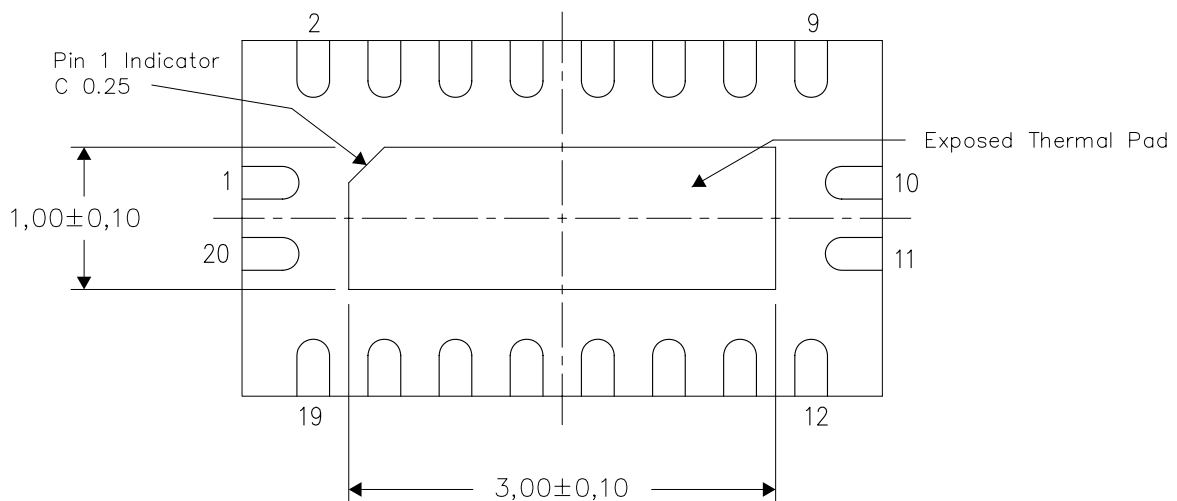

Bottom View

Exposed Thermal Pad Dimensions

4211394/B 01/12

NOTE: All linear dimensions are in millimeters

IMPORTANT NOTICE

Texas Instruments Incorporated (TI) reserves the right to make corrections, enhancements, improvements and other changes to its semiconductor products and services per JESD46, latest issue, and to discontinue any product or service per JESD48, latest issue. Buyers should obtain the latest relevant information before placing orders and should verify that such information is current and complete.

TI's published terms of sale for semiconductor products (<http://www.ti.com/sc/docs/stdterms.htm>) apply to the sale of packaged integrated circuit products that TI has qualified and released to market. Additional terms may apply to the use or sale of other types of TI products and services.

Reproduction of significant portions of TI information in TI data sheets is permissible only if reproduction is without alteration and is accompanied by all associated warranties, conditions, limitations, and notices. TI is not responsible or liable for such reproduced documentation. Information of third parties may be subject to additional restrictions. Resale of TI products or services with statements different from or beyond the parameters stated by TI for that product or service voids all express and any implied warranties for the associated TI product or service and is an unfair and deceptive business practice. TI is not responsible or liable for any such statements.

Buyers and others who are developing systems that incorporate TI products (collectively, "Designers") understand and agree that Designers remain responsible for using their independent analysis, evaluation and judgment in designing their applications and that Designers have full and exclusive responsibility to assure the safety of Designers' applications and compliance of their applications (and of all TI products used in or for Designers' applications) with all applicable regulations, laws and other applicable requirements. Designer represents that, with respect to their applications, Designer has all the necessary expertise to create and implement safeguards that (1) anticipate dangerous consequences of failures, (2) monitor failures and their consequences, and (3) lessen the likelihood of failures that might cause harm and take appropriate actions. Designer agrees that prior to using or distributing any applications that include TI products, Designer will thoroughly test such applications and the functionality of such TI products as used in such applications.

TI's provision of technical, application or other design advice, quality characterization, reliability data or other services or information, including, but not limited to, reference designs and materials relating to evaluation modules, (collectively, "TI Resources") are intended to assist designers who are developing applications that incorporate TI products; by downloading, accessing or using TI Resources in any way, Designer (individually or, if Designer is acting on behalf of a company, Designer's company) agrees to use any particular TI Resource solely for this purpose and subject to the terms of this Notice.

TI's provision of TI Resources does not expand or otherwise alter TI's applicable published warranties or warranty disclaimers for TI products, and no additional obligations or liabilities arise from TI providing such TI Resources. TI reserves the right to make corrections, enhancements, improvements and other changes to its TI Resources. TI has not conducted any testing other than that specifically described in the published documentation for a particular TI Resource.

Designer is authorized to use, copy and modify any individual TI Resource only in connection with the development of applications that include the TI product(s) identified in such TI Resource. NO OTHER LICENSE, EXPRESS OR IMPLIED, BY ESTOPPEL OR OTHERWISE TO ANY OTHER TI INTELLECTUAL PROPERTY RIGHT, AND NO LICENSE TO ANY TECHNOLOGY OR INTELLECTUAL PROPERTY RIGHT OF TI OR ANY THIRD PARTY IS GRANTED HEREIN, including but not limited to any patent right, copyright, mask work right, or other intellectual property right relating to any combination, machine, or process in which TI products or services are used. Information regarding or referencing third-party products or services does not constitute a license to use such products or services, or a warranty or endorsement thereof. Use of TI Resources may require a license from a third party under the patents or other intellectual property of the third party, or a license from TI under the patents or other intellectual property of TI.

TI RESOURCES ARE PROVIDED "AS IS" AND WITH ALL FAULTS. TI DISCLAIMS ALL OTHER WARRANTIES OR REPRESENTATIONS, EXPRESS OR IMPLIED, REGARDING RESOURCES OR USE THEREOF, INCLUDING BUT NOT LIMITED TO ACCURACY OR COMPLETENESS, TITLE, ANY EPIDEMIC FAILURE WARRANTY AND ANY IMPLIED WARRANTIES OF MERCHANTABILITY, FITNESS FOR A PARTICULAR PURPOSE, AND NON-INFRINGEMENT OF ANY THIRD PARTY INTELLECTUAL PROPERTY RIGHTS. TI SHALL NOT BE LIABLE FOR AND SHALL NOT DEFEND OR INDEMNIFY DESIGNER AGAINST ANY CLAIM, INCLUDING BUT NOT LIMITED TO ANY INFRINGEMENT CLAIM THAT RELATES TO OR IS BASED ON ANY COMBINATION OF PRODUCTS EVEN IF DESCRIBED IN TI RESOURCES OR OTHERWISE. IN NO EVENT SHALL TI BE LIABLE FOR ANY ACTUAL, DIRECT, SPECIAL, COLLATERAL, INDIRECT, PUNITIVE, INCIDENTAL, CONSEQUENTIAL OR EXEMPLARY DAMAGES IN CONNECTION WITH OR ARISING OUT OF TI RESOURCES OR USE THEREOF, AND REGARDLESS OF WHETHER TI HAS BEEN ADVISED OF THE POSSIBILITY OF SUCH DAMAGES.

Unless TI has explicitly designated an individual product as meeting the requirements of a particular industry standard (e.g., ISO/TS 16949 and ISO 26262), TI is not responsible for any failure to meet such industry standard requirements.

Where TI specifically promotes products as facilitating functional safety or as compliant with industry functional safety standards, such products are intended to help enable customers to design and create their own applications that meet applicable functional safety standards and requirements. Using products in an application does not by itself establish any safety features in the application. Designers must ensure compliance with safety-related requirements and standards applicable to their applications. Designer may not use any TI products in life-critical medical equipment unless authorized officers of the parties have executed a special contract specifically governing such use. Life-critical medical equipment is medical equipment where failure of such equipment would cause serious bodily injury or death (e.g., life support, pacemakers, defibrillators, heart pumps, neurostimulators, and implantables). Such equipment includes, without limitation, all medical devices identified by the U.S. Food and Drug Administration as Class III devices and equivalent classifications outside the U.S.

TI may expressly designate certain products as completing a particular qualification (e.g., Q100, Military Grade, or Enhanced Product). Designers agree that it has the necessary expertise to select the product with the appropriate qualification designation for their applications and that proper product selection is at Designers' own risk. Designers are solely responsible for compliance with all legal and regulatory requirements in connection with such selection.

Designer will fully indemnify TI and its representatives against any damages, costs, losses, and/or liabilities arising out of Designer's non-compliance with the terms and provisions of this Notice.

Looking for pricing, stock, or lifecycle information?

Click below to explore more details on WIN SOURCE:

 [View SN74GTL2003RKSR on WIN SOURCE](#)

 [Texas Instruments](#) Information

Optimize Your Supply Chain with WIN SOURCE Solutions

-  Global Sourcing Solution
-  Obsolete Management
-  Cost Control Management
-  Shortage Management
-  Alternative Solution
-  Excess Inventory Management