



THE DATASHEET OF FGM623S





SanKen Electric Co., Ltd.
Overseas Sales Headquarters
 Metropolitan Plaza Building, 1-11-1 Nishi-Ikebukuro
 Toshima-ku, Tokyo 171-0021, Japan
 Tel: 81-3-3986-6164
 Fax: 81-3-3986-8637

WORLDWIDE SALES OFFICES

Asia-Pacific

● **China**

SanKen Electric Hong Kong Co., Ltd.
 Suite 1026 Ocean Centre, Canton Road
 Tsimshatsui, Kowloon, Hong Kong
 Tel: 852-2735-5262
 Fax: 852-2735-5494

SanKen Electric (Shanghai) Co., Ltd.
 Room 3202, Maxdo Centre, Xingyi Road 8
 Changning District, Shanghai, China
 Tel: 86-21-5208-1177
 Fax: 86-21-5208-1757

SanKen Electric (Shanghai) Co., Ltd. Shenzhen Office
 Room 1013, Xinhua Insurance Building, Mintian Road, Futian District,
 Shenzhen City, Guangdong, China
 Tel: 86-755-8283-6685
 Fax: 86-755-8826-3053

Taiwan SanKen Electric Co., Ltd.
 Room 1801, 18th Floor, 88 Jung Shiau East Road
 Sec. 2, Taipei 100, Taiwan R.O.C.
 Tel: 886-2-2356-8161
 Fax: 886-2-2356-8261

● **Korea**

SanKen Electric Korea Co., Ltd.
 (Yeouido B/D 16F)24, Gukjegeumyung-ro 2-gil,
 Yeongdeungpo-gu, Seoul 150-734, Korea
 Tel: 82-2-714-3700
 Fax: 82-2-3272-2145

● **Singapore**

SanKen Electric Singapore Pte. Ltd.
 152 Beach Road, #10-06 The Gateway East,
 Singapore 189721
 Tel: 65-6291-4755
 Fax: 65-6297-1744

● **Malaysia**

SanKen Electric (Malaysia) Sdn. Bhd.
 Block B-20-5, Level 20, Northpoint Midvalley City,
 No.1, Medan Syed Putra Utara, 59200 Kuala Lumpur, Malaysia
 Tel: 60-3-2282-2345
 Fax: 60-3-2282-6345

Europe

● **United Kingdom**

SanKen Power Systems (UK) Ltd.
 Pencoed Technology Park
 Pencoed, Bridgend CF35 5HY, United Kingdom
 Tel: 44-1656-869-100
 Fax: 44-1656-869-162

North America

● **United States**

Allegro MicroSystems, Inc.
 115 Northeast Cutoff
 Worcester, Massachusetts 01606, U.S.A.
 Tel: 1-508-853-5000
 Fax: 1-508-853-7895

● This is notification that you, as purchaser of the products/technology, are not allowed to perform any of the following:
 1. Resell or retransfer these products/technology to any party intending to disturb international peace and security.
 2. Use these products/technology yourself for activities disturbing international peace and security.
 3. Allow any other party to use these products/technology for activities disturbing international peace and security.
 Also, as purchaser of these products/technology, you agree to follow the procedures for the export or transfer of these products/technology,
 under the Foreign Exchange and Foreign Trade Law, when you export or transfer the products/technology abroad.



H1-O03EH0-1303015ND

Bulletin No
 O03EH0
 (Mar, 2013)



SEMICONDUCTORS GENERAL CATALOG

ICs
 Transistors
 Thyristors
 Diodes
 DC/DC Power Modules

SEMICONDUCTORS GENERAL CATALOG 2013

SANKEN ELECTRIC CO., LTD.



SANKEN ELECTRIC CO., LTD.
<http://www.sanken-ele.co.jp/en/>

Warning

- The contents in this document are subject to changes, for improvement and other purposes, without notice.
- Be sure to check the delivery specifications before using these products.
- The operation and circuit examples in this document are provided for reference purposes only. Sanken assumes no liability for violation of industrial property, intellectual property, or other rights of Sanken or third parties, that stem from these examples.
- The user must take responsibility for considering and determining which objects the products in this document are used with.
- Although we will continue to improve the quality and reliability of our products, semiconductor products, by their nature, have certain fault and failure rates. The user must take responsibility for designing and checking to secure the device and system so that a part failure may not lead to human injury, fire, damages, or other losses.
- The products in this document are intended for normal electronic devices (such as home appliances, office equipment, communication terminals, or measurement devices). If you are considering using our products for a device that requires high reliability (such as transport machines and their control units, traffic light control systems, disaster prevention, and security equipment or any kind of safety equipment), make sure that you consult our sales representative.
Do not use these products for devices that require extremely high reliability (such as aerospace instruments, nuclear power control units, or life support systems).
- The products in this document are not designed to be radiation-proof.
- The contents in this document must not be transcribed or copied without our written consent.

SANKEN SEMICONDUCTORS

CONTENTS

1 ICs

1-1	Power Management ICs	6
1-1-1	Power Factor Correction (PFC) ICs	6
1-1-2	AC/DC Converter ICs	6
1-1-3	DC/DC Converter ICs	9
1-1-4	Linear Regulator ICs	70
1-2	Motor Driver ICs	92
1-2-1	2-Phase Stepper Motor Unipolar Driver ICs	96
1-2-2	5-Phase Stepper Motor Driver ICs	110
1-2-3	Brush DC Motor Driver ICs	112
1-2-4	Low Voltage 3-Phase Brushless Motor Driver ICs	114
1-2-5	High Voltage 3-Phase Brushless Motor Driver ICs	120
1-3	LED Lighting ICs	134

2 Transistors

2-1	Transistors	157
2-2	MOS FETs	167
2-3	IGBT	171
2-4	Transistors and MOS FET Arrays	174

3 Thyristors

3-1	Thyristors	194
3-2	Triacs	196

4 Diodes

4-1	Rectifier Diodes	207
4-2	Fast Recovery Diodes	208
4-3	Ultrafast Recovery Diodes	210
4-4	Schottky Barrier Diodes	213
4-5	Power Zener Diodes	216
4-6	Silicon Varistors	217

5 DC/DC Power Modules

5	DC/DC Power Modules	221
---	---------------------------	-----

Part Number Index	236
-------------------------	-----

ICs

1

Ordering Information & Standard Packing Quantities	4
1-1 Power Management ICs	6
1-1-1 Power Factor Correction (PFC) ICs	6
1-1-2 AC/DC Converter ICs	6
1-1-3 DC/DC Converter ICs	9
Selection Guide	9
Application Note	11
1-1-4 Linear Regulator ICs	70
Selection Guide	70
Application Note	71
1-2 Motor Driver ICs	92
Selection Guide	92
Application Note	95
1-2-1 2-Phase Stepper Motor Unipolar Driver ICs	96
1-2-2 5-Phase Stepper Motor Driver ICs	110
1-2-3 Brush DC Motor Driver ICs	112
1-2-4 Low Voltage 3-Phase Brushless Motor Driver ICs ..	114
1-2-5 High Voltage 3-Phase Brushless Motor Driver ICs..	120
1-3 LED Lighting ICs	134

Ordering Information

All products listed must be ordered in standard packing increments.

Series Name/ Product Name	Package	Standard Packing Quantities	
		Bulk	Taping
LC52xxD	DIP8	2500	–
LC52xxS	SOP8(Surface-mount)	–	1000
LC55xxD/LD	DIP8	2500	–
LC55xxF/LF	TO220F-7	1800	–
LC57xxS	HSOP8(Surface-mount)	–	1000
NR110K	HSOP8(Surface-mount)	–	1000
NR111E	eSOIC8(Surface-mount)	–	2500
NR117K	HSOP8(Surface-mount)	–	1000
NR119E	eSOIC8(Surface-mount)	–	2500
NR301E	eSOIC8(Surface-mount)	–	2500
NR885E	eSOIC8(Surface-mount)	–	2500
NR885K	HSOP8(Surface-mount)	–	1000
NR887D	DIP8	2500	–
SAI	PS4(Surface-mount)	–	2000
SCM1240M	DIP33Pin	LF.No.2551/2552: 250	–
SI-3000KD	TO263-5(Surface-mount)	–	800
SI-3000KF	TO220F-5	2000	–
SI-3000KS	SOP8(Surface-mount)	–	1000
SI-3000LLSL	SOP8(Surface-mount)	–	1000
SI-3000LSA	SOP8(Surface-mount)	–	1000
SI-3000LU	SOT89-5(Surface-mount)	–	1000
SI-3000ZD	TO263-5(Surface-mount)	–	800
SI-3000ZF	TO220F-5	2000	–
SI-6633C	QFN36(Surface-mount)	–	2500
SI-6633M	QFN36(Surface-mount)	–	2500
SI-7321M	HSOP44(Surface-mount)	–	2000
SI-7510	DIP30	680	–
SI-8000E	TO220F-5	2000	–
SI-8000FD	TO263-5(Surface-mount)	–	800
SI-8000FFE	TO220F-5	2000	–
SI-8000GL	DIP8	2500	–
SI-8000HD	TO263-5(Surface-mount)	–	800
SI-8000HFE	TO220F-5	2000	–
SI-8000JD	TO263-5(Surface-mount)	–	800
SI-8000JF	TO220F-5	2000	–
SI-8000Q	HSOP8(Surface-mount)	–	1000
SI-8000S	TO220F-5	2000	–
SI-8000SD	TO263-5(Surface-mount)	–	800
SI-8000TFE	TO220F-5	2000	–
SI-8000TM	TO252-5(Surface-mount)	–	3000
SI-8000W	SOP8(Surface-mount)	–	1000
SI-8000Y	TO220F-7	2000	–
SI-8100QL	DIP8	2500	–

Series Name/ Product Name	Package	Standard Packing Quantities	
		Bulk	Taping
SI-8205NHD	HSOP8(Surface-mount)	–	1000
SI-8205NHG	HSOP8(Surface-mount)	–	1000
SI-8400L	Non-package type (EI-12.5 core)	864	–
SI-8500L	Non-package type (EI-19 core)	320	–
SI-8511NVS	TSSOP24(Surface-mount)	–	2800
SIM6800M	DIP40Pin	LF.No.2971: 1080	–
SLA686xMZ	SIP24 with Fin (SLA24Pin)	LF.No.2171: 648, LF.No.2175: 540	–
SLA7022MU/ 7029M	ZIP15 with Fin (SLA15Pin)	1080	–
SLA7024M/ 7026M/7027MU	ZIP18 with Fin (SLA18Pin)	1080	–
SLA707xMR/MPR /MPRT	ZIP23 with Fin (SLA23Pin)	1080	–
SLA708xMPR	ZIP23 with Fin (SLA23Pin)	1080	–
SMA682xMH/ 686xMZ	SIP24 (SMA24Pin)	LF.No.2451: 1080, LF.No.2452: 1008	–
SMA7022MU/ 7029M	ZIP15 (SMA15Pin)	1440	–
SPI-6631M	HSOP16(Surface-mount)	–	1400
SPI-8000A	HSOP16(Surface-mount)	–	1400
SPI-8000TW	HSOP16(Surface-mount)	–	1400
SSC2000	SOP8(Surface-mount)	–	1000
SSC2100	SOP8(Surface-mount)	–	1000
SSC9512	DIP16	1250	–
SSC9522S	SOP18(Surface-mount)	–	2000
STA6940M	ZIP18(STA18Pin)	LF.No.434: 1785	–
STA713xMPR	ZIP18(STA18Pin)	LF.No.434: 1785	–
STA801M	ZIP10(STA10Pin)	100	–
STR2W100	TO220F-6	1800	–
STR3A100	DIP8	2500	–
STR-A6000	DIP8	2500	–
STR-A6100	DIP8	2500	–
STR-L400	SIP10(STA10Pin)	3300	–
STR-L6400	SIP10(STA10Pin)	3300	–
STR-V100	SIP8(STA8Pin)	4050	–
STR-V600	SIP8(STA8Pin)	4050	–
STR-W6000S	TO220F-6	1800	–
STR-W6200D	TO220F-6	1800	–
STR-W6700	TO220F-6	1800	–
STR-X6700	TO3PF-7	500	–
STR-Y6400	TO220F-7	1800	–
STR-Y6700	TO220F-7	1800	–

Series Name/ Product Name	Package	Standard Packing Quantities	
		Bulk	Taping
SX68000MH	SOP27(Surface-mount)	–	LF1890: 3000

1-1 Power Management ICs

1-1-1 Power Factor Correction (PFC) ICs

Control ICs

● Continuous Conduction Mode (CCM) PFC Control IC

For high power and high efficiency applications, with brown-in and brown-out functions

Series Name	Part Number	Oscillation Frequency	Package
SSC2000	SSC2001S	Fixed to 65kHz	SOP8

● Interleaved Discontinuous Conduction Mode (DCM) PFC Control IC

8-pin package, minimum number of discrete components, low noise, and low ripple

Series Name	Part Number	Maximum on time	Package
SSC2100	SSC2101S	15 μ s	SOP8
	SSC2102S	20.7 μ s	SOP8

1-1-2 AC/DC Converter ICs

● PWM type

<STR-3A100 Series>

- For small power applications
- Low noise, low standby power (Input power P_{IN} < 15mW at no load)

Part Number	Oscillation Frequency	MOSFET		Overvoltage and Thermal Protection Operation	Package
		V _{DSS} (MIN)	R _{DS(ON)} (MAX)		
STR3A151	67kHz	650V	4.0 Ω	Latch	DIP8
STR3A152			3.0 Ω		
STR3A153			1.9 Ω		
STR3A154			1.4 Ω		
STR3A155			1.1 Ω		
STR3A151D	67kHz	650V	4.0 Ω	Auto restart	
STR3A152D			3.0 Ω		
STR3A153D			1.9 Ω		
STR3A154D			1.4 Ω		
STR3A155D			1.1 Ω		
STR3A161HD	100kHz	700V	4.2 Ω	Auto restart	
STR3A162HD			3.2 Ω		
STR3A163HD			2.2 Ω		

<STR-A6000 Series>

- For small power applications
- Low noise, low standby power (Input power P_{IN} < 25mW at no load)
- Brown-in and brown-out functions

Part Number	Oscillation Frequency	MOSFET		Package
		V _{DSS} (MIN)	R _{DS(ON)} (MAX)	
STR-A6051M	67kHz	650V	3.95 Ω	DIP8
STR-A6052M			2.8 Ω	
STR-A6053M			1.9 Ω	
STR-A6079M			800V	
STR-A6059H	100kHz	700V	6 Ω	
STR-A6061H			3.95 Ω	
STR-A6062H			2.8 Ω	
STR-A6069H			6 Ω	
STR-A6061HD*	100kHz	700V	3.95 Ω	
STR-A6062HD*			2.8 Ω	
STR-A6063HD*			2.3 Ω	
STR-A6069HD*			6 Ω	

- In addition to normal overcurrent protection, overcurrent protection that operates in the case of a short circuit at the output coil has been added. This overcurrent protection operates during the leading edge blanking period.

<STR-V600 Series>

- Low height, at least 4 mm of creepage isolation between high and low terminal tips
- Low noise, low standby power (Input power P_{IN} < 25mW at no load)
- SIP8 package version of STR-A6000

Part Number	Oscillation Frequency	MOSFET		Package
		V _{DSS} (MIN)	R _{DS(ON)} (MAX)	
STR-V653	67kHz	650V	1.9 Ω	SIP8

<STR2W100D Series>

- Low noise, low standby power (Input power P_{IN} < 25mW at no load)

Part Number	Oscillation Frequency	MOSFET		Package
		V _{DSS} (MIN)	R _{DS(ON)} (MAX)	
STR2W152D	67kHz	650V	3.0 Ω	TO220F-6
STR2W153D			1.9 Ω	

<STR-W6000S Series>

- Low noise, low standby power (Input power $P_{IN}<30mW$ at no load)
- Brown-in and brown-out functions

Part Number	Oscillation Frequency	MOSFET		Package
		V_{DSS} (MIN)	$R_{DS(ON)}$ (MAX)	
STR-W6051S	67kHz	650V	3.95 Ω	TO220F-6
STR-W6052S			2.8 Ω	
STR-W6053S			1.9 Ω	

<STR-W6200D Series>

- Low noise, low standby power (Input power $P_{IN}<40mW$ at no load)
- External latch protection (ELP) function

Part Number	Oscillation Frequency	MOSFET		Package
		V_{DSS} (MIN)	$R_{DS(ON)}$ (MAX)	
STR-W6251D	67kHz	650V	3.95 Ω	TO220F-6
STR-W6252D			2.8 Ω	
STR-W6253D			1.9 Ω	

●Pulse ratio control (PRC) type with off-time period fixed (originated by Sanken Electric)

<STR-A6100 Series>

- For small power applications
- Low noise, low standby power

Part Number	Fixed off-time period	MOSFET		Auto standby function	Package
		V_{DSS} (MIN)	$R_{DS(ON)}$ (MAX)		
STR-A6131	8 μ s	500V	3.95 Ω	Yes	DIP8
STR-A6132			2.62 Ω		
STR-A6159		650V	6 Ω		
STR-A6151			3.95 Ω		
STR-A6169	800V	19.2 Ω	No		
STR-A6131M	650V	500V		3.95 Ω	
STR-A6159M		6 Ω			
STR-A6151M		3.95 Ω			
STR-A6153E		1.9 Ω			

<STR-V100 Series>

- Low height, at least 4 mm of creepage isolation between high and low terminal tips
- Low noise, low standby power
- SIP8 package version of STR-A6100

Part Number	Fixed off-time period	MOSFET		Package
		V_{DSS} (MIN)	$R_{DS(ON)}$ (MAX)	
STR-V152	8 μ s	650V	2.8 Ω	SIP8
STR-V153	11.5 μ s		2 Ω	

●Quasi-resonant type

<STR-Y6700 Series>

- High efficiency in full load range
- Low noise, low standby power

Part Number	MOSFET		Package
	V_{DSS} (MIN)	$R_{DS(ON)}$ (MAX)	
STR-Y6735	500V	0.8 Ω	TO220F-7
STR-Y6753	650V	1.9 Ω	
STR-Y6754		1.4 Ω	
STR-Y6763	800V	3.5 Ω	
STR-Y6765		2.2 Ω	
STR-Y6766		1.7 Ω	

<STR-Y6400 Series>

- High efficiency in full load range
- Low noise, low standby power
- Mode change delay time adjustable

Part Number	MOSFET		Package
	V_{DSS} (MIN)	$R_{DS(ON)}$ (MAX)	
STR-Y6453	650V	1.8 Ω	TO220F-7
STR-Y6456		0.73 Ω	
STR-Y6473	850V	3.6 Ω	
STR-Y6476		1.3 Ω	

1-1-2 AC/DC Converter ICs

<STR-L6400 Series>

- Low height, at least 6.5 mm of creepage isolation between high and low terminal tips
- High efficiency in full load range, low noise, and low standby power
- SIP10 package version of STR-Y6400

Part Number	MOSFET		Package
	V _{DSS} (MIN)	R _{DS(ON)} (MAX)	
STR-L6472	850V	6.5Ω	SIP10

<STR-L400 Series>

- Low height, at least 6.5 mm of creepage isolation between high and low terminal tips
- Low noise, high efficiency

Part Number	MOSFET		Package
	V _{DSS} (MIN)	R _{DS(ON)} (MAX)	
STR-L451	650V	3.95Ω	SIP10
STR-L472	900V	7.7Ω	

<STR-W6700 Series>

- High efficiency in full load range
- Low noise, undervoltage lockout (UVLO) standby function

Part Number	MOSFET		Auto burst operation	Bottom-skip QR operation	Package
	V _{DSS} (MIN)	R _{DS(ON)} (MAX)			
STR-W6734	500V	1.0Ω	Yes	Yes	TO220F-6
STR-W6735		0.57Ω			
STR-W6753		1.7Ω			
STR-W6754	650V	0.96Ω			
STR-W6756		0.73Ω			
STR-W6765	800V	1.8Ω	Yes	No	
STR-W6750F	650V	0.73Ω	No	Yes	
STR-W6723N	450V	1.4Ω			
STR-W6735N	500V	0.57Ω			
STR-W6756N	650V	0.73Ω			
STR-W6765N	800V	1.8Ω			

<STR-X6700 Series>

- High efficiency in full load range
- Low noise, undervoltage lockout (UVLO) standby function

Part Number	MOSFET		Auto burst operation	Bottom-skip QR operation	Package
	V _{DSS} (MIN)	R _{DS(ON)} (MAX)			
STR-X6737	500V	0.36Ω	Yes	Yes	TO3PF-7
STR-X6756	650V	0.73Ω			
STR-X6757		0.62Ω			
STR-X6769		800V			
STR-X6750B	650V	0.62Ω	No	No	
STR-X6759B		0.385Ω			
STR-X6769B	800V	0.66Ω	Yes	No	
STR-X6750F	650V	0.62Ω			
STR-X6759F		0.385Ω			
STR-X6729	450V	0.189Ω	No	Yes	
STR-X6737M	500V	0.36Ω			
STR-X6757N	650V	0.62Ω			
STR-X6759N		0.385Ω			
STR-X6768N		800V			1.0Ω

● Current resonance type

- Half-bridge resonance
- High efficiency, low noise
- Brown-in and brown-out functions

Part Number	Package
SSC9512	DIP16
SSC9522S	SOP18

Selection Guide

<Single Output>

Surface-Mount Type

Series Name	Output Current (A)	Output Voltage (V)				Variable (Reference Voltage) (V)			Maximum Input Voltage (V)	Oscillation Frequency (kHz)	Package	Remarks	Page
		3.3	5.0	9.0	12	0.5	0.8	1.0					
SAI	0.4				○				35	60	PS-4		12
	0.5	○	○										
SI-8000W	0.6	○	○						35	60	SOP8		14
SI-8000JD	1.5	○	○	○	○				43	125	TO263-5		16
SI-8000TM	1.5						○		43	300	TO252-5		18
NR117K	1.5						○		35	30	HSOP8	Current mode control	20
NR119E	2.0						○		35	364	eSOIC8	Current mode control	20
NR885E	3.0						○		20	350	eSOIC8	Current mode control, synchronous rectifier	22
NR885K	3.0						○		20	350	HSOP8	Current mode control, synchronous rectifier	22
SI-8205NHD	3.0						○		46	200 to 1000	HSOP8	Current mode control, synchronous rectifier	24
SI-8205NHG	3.0						○		46	300 to 1000	HSOP8	Current mode control, external synchronization	24
SI-8000SD	3.0	○	○						43*1	60	TO263-5		26
SPI-8000A	3.0							○	53	250	HSOP16		28
SI-8000Q	3.5						○		30	500	HSOP8	Current mode control	32
SI-8000FDE	3.5						○		43	300	TO263-5		34
SI-8000FDL	3.5						○		43	300	TO263-5	Active: low	34
NR110K	4.0						○		35	350	HSOP8	Current mode control	20
NR111E	4.0						○		35	350	eSOIC8	Current mode control	20
SI-8000HD	5.5						○		43	150	TO263-5		36

*1: 35V for SI-8033SD

Thru-Hole Type

Series Name	Output Current (A)	Output Voltage (V)					Variable (Reference Voltage) (V)				Maximum Input Voltage (V)	Oscillation Frequency (kHz)	Package	Remarks	Page
		3.3	5.0	9.0	12	15	0.5	0.8	1.0	1.5					
SI-8400L	0.5		○								35	60	Non-package type	With coil and built-in diode	60
SI-8000E	0.6		○								43	60	TO220F-5		38
SI-8500L	1.0		○								35	60	Non-package type	With coil and built-in diode	60
SI-8000JF	1.5	○	○		○				○		43	125	TO220F-5		40
SI-8000TFE	1.5		○					○			43	300	TO220F-5		42
SI-8000GL	1.5								○		53	250	DIP8		44
NR887D	2.0							○			20	500	DIP8	Current mode control, synchronous rectifier	46
SI-8000S	3.0	○	○	○	○	○					43*2	60	TO220F-5		48
SI-8100QL	3.5						○				30	350	DIP8	Current mode control	50
SI-8000FFE	3.5							○			43	300	TO220F-5		52
NR111D	4.0							○			35	350	DIP8	Current mode control	54
SI-8000HFE	5.5		○					○			43	150	TO220F-5		56
SI-8000Y	8.0		○						○		45	130	TO220F-7	Current mode control	58

*2: 35V for SI-8033S

<Multi Output>

Part Number		Output Current	Output Voltage	Maximum Input Voltage	Oscillation Frequency	Package	Remarks	Page
		(A)	(V)	(V)	(kHz)			
STA801M	ch1	0.5	5	43	125	ZIP10	Built-in flywheel diode	62
	ch2	0.5	Select from 9.0, 11.5, 12.1, and 15.5					
SPI-8001TW	ch1	1.5	Variable (1.0 to 16 V)	21	250	HSOP16		64
	ch2	1.5	Variable (1.0 to 16 V)					
SPI-8002TW	ch1	1.5	Variable (1.0 to 24 V)	40	250	HSOP16		64
	ch2	1.5	Variable (1.0 to 24 V)					
SPI-8003TW	ch1	1.5	Variable (1.0 to 24 V)	40	200 to 400	HSOP16	Frequency variable	64
	ch2	1.5	Variable (1.0 to 24 V)					

<Control ICs>

Series Name	Variable (Reference Voltage)	Maximum Input Voltage	Oscillation Frequency	Package	Remarks	Page
	(V)	(V)	(kHz)			
SI-8511NVS	1.1	25	100 to 400	TSSOP24	Synchronous rectifier, PRC (fixed to ton)	68

Application Note

Heat Dissipation and Reliability

The reliability of an IC is highly dependent on its operating temperature. Please be sure to apply silicone grease to the IC and to mount it to the heatsink with a proper mounting torque.

Heatsink design should pay particular attention to ensuring sufficient heat dissipation capacity.

In addition, please take into account the air convection in operation.

The reliability of discrete components such as capacitors and coils is closely related to temperature. A high operating temperature may reduce the service life. Exceeding the allowable temperature may burn the coils or damage capacitors. It is important to make sure that the temperature of output smoothing coils and input/output capacitors do not exceed their allowable levels during operation. With an adequate derating for the coils, minimize heat emission as far as possible. (For discrete components, refer to the individual user manuals.)

Internal Power Dissipation

P_D can be obtained from the following formula.

- For the device with built-in flywheel diode:

$$P_D = V_O \cdot I_O \left(\frac{100}{\eta\chi} - 1 \right)$$

- For the device with external flywheel diode:

$$P_D = V_O \cdot I_O \left(\frac{100}{\eta\chi} - 1 \right) - V_F \cdot I_O \left(1 - \frac{V_O}{V_{IN}} \right)$$

Efficiency $\eta\chi$ depends on the input/output conditions. Please refer to the efficiency characteristics of the devices. (Posted on the Web site.)

V_O : Output voltage
 V_{IN} : Input voltage
 I_O : Output current
 $\eta\chi$: Efficiency(%)
 V_F : Diode forward voltage

Thermal Design

The maximum junction temperature $T_{j(max)}$ given in the Absolute Maximum Ratings is specific to each product type and must be strictly observed. Thus, thermal design must consider the maximum power dissipation $P_{D(max)}$, which varies by the conditions of use, and the maximum ambient temperature $T_{a(max)}$.

To simplify thermal design, T_a - P_D characteristic graphs are provided herein. Please observe the following steps for heatsink design:

- Obtain the maximum ambient temperature $T_{a(max)}$.
- Obtain the maximum power dissipation $P_{D(max)}$.
- Look for the intersection point on the T_a - P_D characteristic graph and determine the size of the heatsink.

Although the heatsink size is now obtained, in actual applications, 10-to-20% derating factor is generally introduced. Moreover, the heat dissipation capacity of a heatsink highly depends on how it is mounted. Thus, it is recommended to measure the heatsink and case temperature in the actual operating environment.

Please refer to the T_a - P_D characteristic graphs for respective product types.

Mounting Torque

SI-8000E	0.588 to 0.686[N·m] (6.0 to 7.0[kgf·cm])
SI-8000JF	
SI-8000S	
SI-8000TFE	
SI-8000HFE	
SI-8000FFE	
SI-8000Y	

Recommended Silicone Grease

- Shin-Etsu Chemical Co., Ltd.: G746
- Momentive Performance Materials Inc.: YG-6260
- Dow Corning Toray Silicone Co., Ltd.: SC102

Please select proper silicone grease carefully since the oil in some grease products may penetrate the device and result in an extremely short device life.

Others

- Devices can not be operated in parallel connection aiming for a larger current.
- Not applicable for the current boost or voltage step-up use.

Rectifier Diodes for Power Supplies

To rectify the AC input using rectifier diodes in power supplies, please use SANKEN rectifier diodes shown in the following list. (Please use a center-tap or bridge configuration in using stand-alone type diodes.)

Series Name	Diodes
SAI	
SI-8000W	
SI-8000JD	
SI-8000TM	
NR117K	
NR119E	
NR885E	
NR885K	SJPM-H4 (Surface-Mount Stand-Alone Type, $V_{RM}=400V, I_O=2.0A$)
SI-8205NHD	
SI-8205NHG	
SI-8000SD	
SPI-8000A	
SI-8005Q	
SI-8001FDE	
SI-8001FDL	
SI-8008HD	
SI-8000HFE	FMM-22S,R (Center-tap Type, $V_{RM}=200V, I_O=10A$)
SI-8000Y	
SI-8400L	
SI-8000E	
SI-8500L	AM01Z (Axial Type, $V_{RM}=200V, I_O=1.0A$)
SI-8000JF	
SI-8000TFE	
SI-8000GL	
NR887D	RM10Z (Axial Type, $V_{RM}=200V, I_O=1.5A$)
SI-8000S	
NR110K	
NR111E	RM4Z (Axial Type, $V_{RM}=200V, I_O=3.0A$)
SI-8100QL	
SI-8000FFE	
STA801M	AM01Z (Axial Type, $V_{RM}=200V, I_O=1.0A$)
SPI-8000TW	SJPM-H4 (Surface-Mount Stand-Alone Type, $V_{RM}=400V, I_O=2.0A$)

SAI Series Surface-Mount, Separate Excitation Step-down Switching Mode

■Features

- Surface-mount power package
- Output current: 0.4 to 0.5A
- High efficiency: 75 to 88%
- Requires only 4 discrete components
- Internally-adjusted phase compensation and output voltage
- Built-in reference oscillator (60kHz)
- Built-in overcurrent and thermal protection circuits

■Lineup

Part Number	SAI01	SAI02	SAI03
V _o (V)	5.0	3.3	12.0
I _o (A)	0.5		0.4

■Absolute Maximum Ratings

Parameter	Symbol	Ratings	Unit
DC Input Voltage	V _{IN}	35	V
Power Dissipation	P _D	0.75	W
Junction Temperature	T _J	+125	°C
Storage Temperature	T _{stg}	-40 to +125	°C
Thermal Resistance(junction to case)	θ _{J-C}	20	°C/W

■Applications

- Power supplies for telecommunication equipment
- Onboard local power supplies

■Recommended Operating Conditions

Parameter	Symbol	Ratings			Unit
		SAI01	SAI02	SAI03	
DC Input Voltage Range	V _{IN}	7 to 33	5.3 to 28	15 to 33	V
Output Current Range	I _o	0 to 0.5			A
Operating Junction Temperature Range	T _{top}	-30 to +125			°C

■Electrical Characteristics

(T_a=25°C)

Parameter	Symbol	Ratings									Unit
		SAI01			SAI02			SAI03			
		min.	typ.	max.	min.	typ.	max.	min.	typ.	max.	
Output Voltage	V _o	4.80	5.00	5.20	3.17	3.30	3.43	11.40	12.00	12.60	V
Conditions	V _{IN} =20V, I _o =0.3A			V _{IN} =15V, I _o =0.3A			V _{IN} =24V, I _o =0.3A				
Efficiency	η	80			75			88			%
Conditions	V _{IN} =20V, I _o =0.3A			V _{IN} =15V, I _o =0.3A			V _{IN} =24V, I _o =0.3A				
Oscillation Frequency	f	60			60			60			kHz
Conditions	V _{IN} =20V, I _o =0.3A			V _{IN} =15V, I _o =0.3A			V _{IN} =24V, I _o =0.3A				
Line Regulation	ΔV _{OLINE}	80			60			100			mV
Conditions	V _{IN} =10 to 30V, I _o =0.3A			V _{IN} =8 to 28V, I _o =0.3A			V _{IN} =18 to 30V, I _o =0.3A				
Load Regulation	ΔV _{OLOAD}	30			20			70			mV
Conditions	V _{IN} =20V, I _o =0.1 to 0.4A			V _{IN} =15V, I _o =0.1 to 0.4A			V _{IN} =24V, I _o =0.1 to 0.4A				
Temperature Coefficient of Output Voltage	ΔV _o /ΔT _a	±0.5			±0.5			±1.5			mV/°C
Conditions	45			45			45				
Ripple Rejection	R _{REJ}	45			45			45			dB
Conditions	f=100 to 120Hz			f=100 to 120Hz			f=100 to 120Hz				
Overcurrent Protection Starting Current	I _{s1}	0.55			0.55			0.45			A
Conditions	V _{IN} =10V			V _{IN} =8V			V _{IN} =18V				

External Dimensions (PS4)

(Unit : mm)

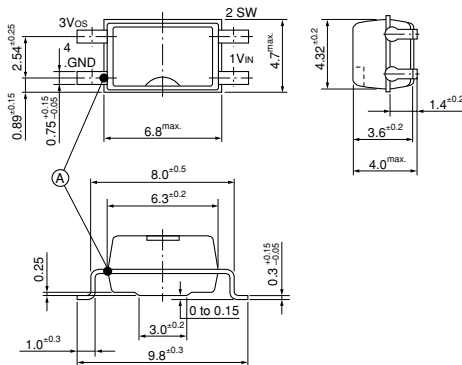

Ⓐ Case Temperature Measuring Point

Pin Assignment

- ① VIN
- ② SWOUT
- ③ Vos
- ④ GND

Plastic Mold Package Type

Flammability: UL94V-0

Product Mass: Approx. 0.22g

Block Diagram

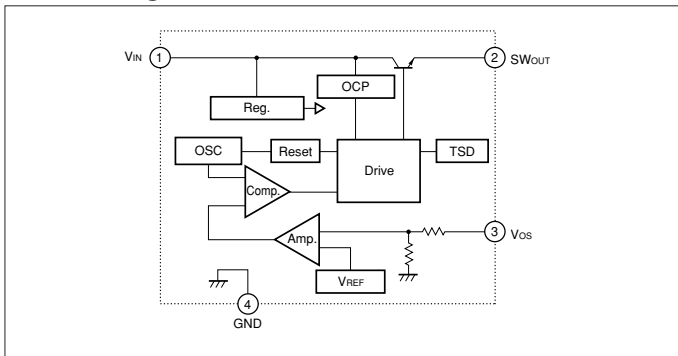

Typical Connection Diagram

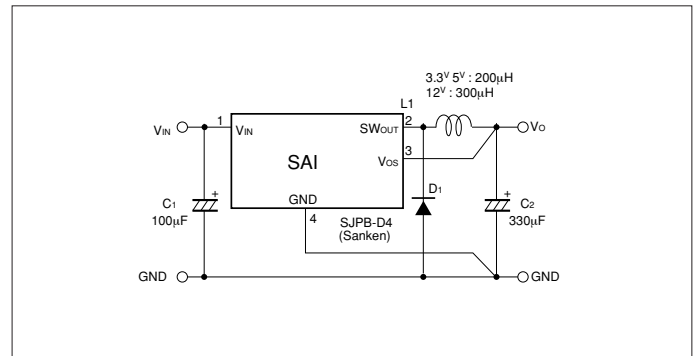

Ta-Pd Characteristics

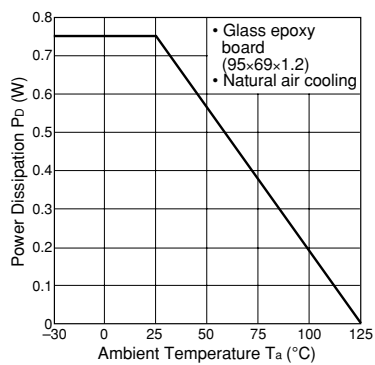

$$P_D = V_O \cdot I_O \left(\frac{100}{\eta\chi} - 1 \right) - V_F \cdot I_O \left(1 - \frac{V_O}{V_{IN}} \right)$$

The efficiency depends on the input voltage and the output current. Therefore, obtain the value from the efficiency graph and substitute the percentage in the formula above.

- Vo : Output voltage
- Io : Output current
- ηχ : Efficiency (%)
- V_F : Diode D₁ forward voltage
SJPB-D4-0.3V

Thermal design for D₁ must be considered separately.

SI-8000W Series Surface-Mount, Separate Excitation Step-down Switching Mode

■ Features

- Surface-mount package (SOP8)
- Output current: 0.6A
- High efficiency: 75 to 80%
- Requires only 4 discrete components
- Internally-adjusted phase compensation and output voltage adjustment performed internally
- Built-in reference oscillator (60kHz)
- Built-in overcurrent and thermal protection circuits

■ Absolute Maximum Ratings

Parameter	Symbol	Ratings	Unit
DC Input Voltage	V_{IN}	35	V
Power Dissipation	P_D	1	W
Junction Temperature	T_j	-30 to +125	°C
Storage Temperature	T_{stg}	-40 to +125	°C
Thermal Resistance (Junction to 7-Pin Lead)	θ_{j-L}	22	°C/W
Thermal Resistance (Junction to Ambient Air) ^{*1}	θ_{j-a}	100	°C/W

*1: Glass-epoxy board of 40 × 40mm (copper laminate area 4.3%)

■ Applications

- Power supplies for telecommunication equipment
- Onboard local power supplies

■ Recommended Operating Conditions

Parameter	Symbol	Ratings		Unit
		SI-8033W	SI-8050W	
DC Input Voltage Range	V_{IN}	5.3 to 28	7 to 33	V
Output Current Range	I_O	0 to 0.6		A
Operating Junction Temperature Range	T_{jop}	-30 to +125		°C

■ Electrical Characteristics

($T_a=25^\circ\text{C}$)

Parameter	Symbol	Ratings						Unit
		SI-8033W			SI-8050W			
		min.	typ.	max.	min.	typ.	max.	
Output Voltage	V_O	3.17	3.30	3.43	4.80	5.00	5.20	V
	Conditions	$V_{IN}=15\text{V}, I_O=0.3\text{A}$			$V_{IN}=20\text{V}, I_O=0.3\text{A}$			
Efficiency	η	75			80			%
	Conditions	$V_{IN}=15\text{V}, I_O=0.3\text{A}$			$V_{IN}=20\text{V}, I_O=0.3\text{A}$			
Oscillation Frequency	f	60			60			kHz
	Conditions	$V_{IN}=15\text{V}, I_O=0.3\text{A}$			$V_{IN}=20\text{V}, I_O=0.3\text{A}$			
Line Regulation	ΔV_{OLINE}	60			80			mV
	Conditions	$V_{IN}=8\text{ to }28\text{V}, I_O=0.3\text{A}$			$V_{IN}=10\text{ to }30\text{V}, I_O=0.3\text{A}$			
Load Regulation	ΔV_{OLOAD}	20			30			mV
	Conditions	$V_{IN}=15\text{V}, I_O=0.1\text{ to }0.4\text{A}$			$V_{IN}=20\text{V}, I_O=0.1\text{ to }0.4\text{A}$			
Temperature Coefficient of Output Voltage	$\Delta V_O/\Delta T_a$	± 0.5			± 0.5			mV/°C
Ripple Rejection	R_{REJ}	45			45			dB
	Conditions	$f=100\text{ to }120\text{Hz}$			$f=100\text{ to }120\text{Hz}$			
Overcurrent Protection Starting Current	I_{S1}	0.61			0.61			A
	Conditions	$V_{IN}=15\text{V}$			$V_{IN}=20\text{V}$			

External Dimensions (SOP8)

(Unit : mm)

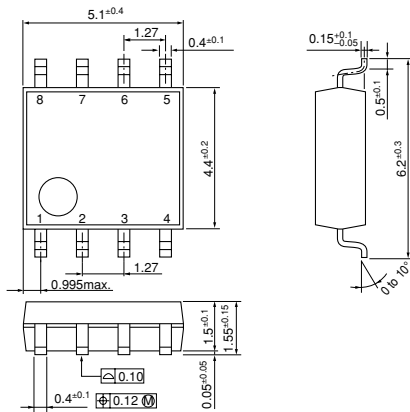

Pin Assignment

- ① VIN
- ② N.C
- ③ SW
- ④ Vos
- ⑤ GND
- ⑥ GND
- ⑦ GND
- ⑧ GND

Plastic Mold Package Type
 Flammability: UL94V-0
 Product Mass: Approx. 0.1g

Block Diagram

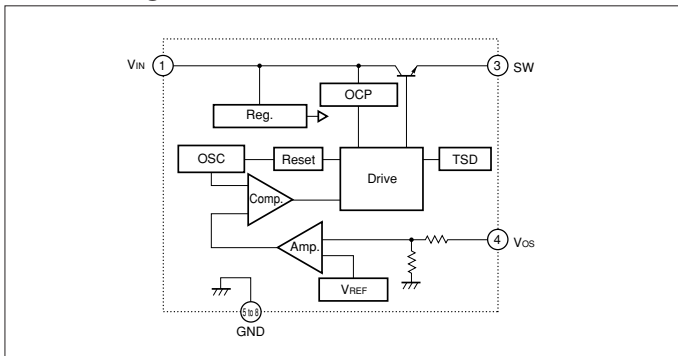

Typical Connection Diagram

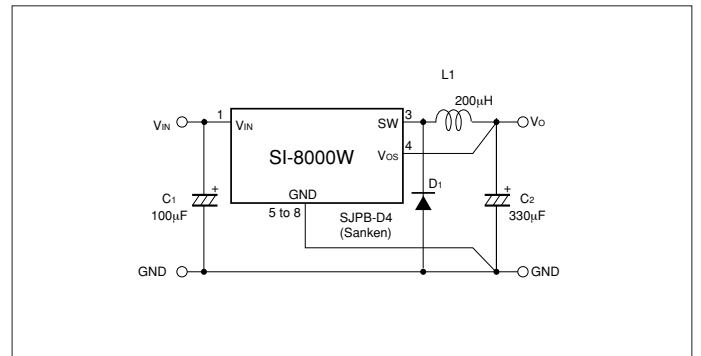

Reference Data

Copper Laminate Area vs. Power Dissipation

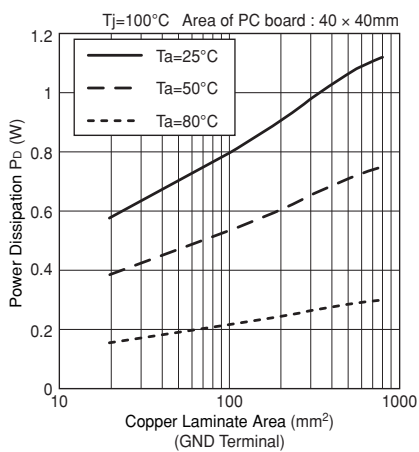

Copper Laminate Area vs. Thermal Resistance θ_{j-a}

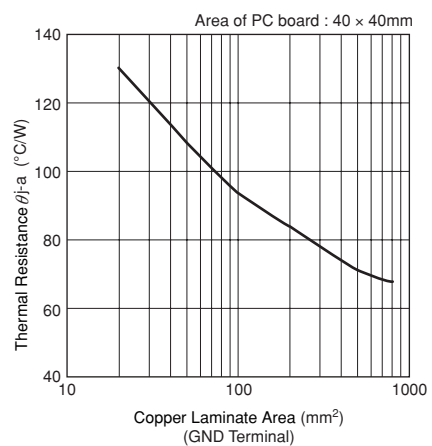

SI-8000JD Series Surface-Mount, Separate Excitation Step-down Switching Mode

■Features

- Surface-mount package (TO263-5)
- Output current: 1.5A
- High efficiency: 77 to 88%
- Requires only 4 discrete components
- Internally-adjusted phase compensation and output voltage
- Capable of downsizing a choke-coil due to IC's high switching frequency (125 kHz). (Compared with conventional Sanken devices)
- Built-in foldback-overcurrent and thermal protection circuits
- Output ON/OFF available (Circuit current at output OFF: 200μA max)
- Soft start available by ON/OFF pin Conditions

■Lineup

Part Number	SI-8033JD	SI-8050JD	SI-8090JD	SI-8120JD
Vo(V)	3.3	5.0	9.0	12.0
Io(A)	1.5			

■Absolute Maximum Ratings

Parameter	Symbol	Ratings	Unit	Conditions
DC Input Voltage	V _{IN}	43	V	
Output Current	I _o	1.5	A	
Power Dissipation*	P _d	3	W	When mounted on glass-epoxy board 40 × 40 mm (copper area 100%)
Junction Temperature	T _j	+125	°C	
Storage Temperature	T _{stg}	-40 to +125	°C	
Thermal Resistance (Junction to Case)	θ _{J-C}	3	°C/W	
Thermal Resistance (Junction to Ambient Air)	θ _{J-A}	33.3	°C/W	When mounted on glass-epoxy board 40 × 40 mm (copper area 100%)

*: Limited by thermal protection circuit

■Applications

- Power supplies for telecommunication equipment
- Onboard local power supplies, etc.

■Recommended Operating Conditions

Parameter	Symbol	Ratings				Unit	Conditions
		SI-8033JD	SI-8050JD	SI-8090JD	SI-8120JD		
DC Input Voltage Range	V _{IN1}	5.3 to 40	7 to 40	11 to 40	14 to 40	V	I _o =0 to 1A
	V _{IN2}	6.3 to 40	8 to 40	12 to 40	15 to 40		I _o =0 to 1.5A
DC Output Current Range*	I _o	0 to 1.5				A	V _{IN} ≥V _O +3V
Operating Junction Temperature Range	T _{TOP}	-30 to +125				°C	
Operating Temperature Range*	T _{OP}	-30 to +125				°C	

*: Limited by Ta-Pd characteristics

■Electrical Characteristics

(T_a=25°C)

Parameter	Symbol	Ratings												Unit
		SI-8033JD			SI-8050JD			SI-8090JD			SI-8120JD			
		min.	typ.	max.	min.	typ.	max.	min.	typ.	max.	min.	typ.	max.	
Output Voltage	V _o	3.234	3.30	3.366	4.90	5.00	5.10	8.82	9.00	9.18	11.76	12.00	12.24	V
	Conditions	V _{IN} =15V, I _o =0.5A			V _{IN} =20V, I _o =0.5A			V _{IN} =21V, I _o =0.5A			V _{IN} =24V, I _o =0.5A			
Efficiency	η	77			82			86			88			%
	Conditions	V _{IN} =15V, I _o =0.5A			V _{IN} =20V, I _o =0.5A			V _{IN} =21V, I _o =0.5A			V _{IN} =24V, I _o =0.5A			
Oscillation Frequency	f	125			125			125			125			kHz
	Conditions	V _{IN} =15V, I _o =0.5A			V _{IN} =20V, I _o =0.5A			V _{IN} =21V, I _o =0.5A			V _{IN} =24V, I _o =0.5A			
Line Regulation	ΔV _{OLINE}	25 80			40 100			50 120			60 130			mV
	Conditions	V _{IN} =8 to 30V, I _o =0.5A			V _{IN} =10 to 30V, I _o =0.5A			V _{IN} =15 to 30V, I _o =0.5A			V _{IN} =18 to 30V, I _o =0.5A			
Load Regulation	ΔV _{OLOAD}	10 30			10 40			10 40			10 40			mV
	Conditions	V _{IN} =15V, I _o =0.2 to 0.8A			V _{IN} =20V, I _o =0.2 to 0.8A			V _{IN} =21V, I _o =0.2 to 0.8A			V _{IN} =24V, I _o =0.2 to 0.8A			
Temperature Coefficient of Output Voltage	ΔV _O /ΔT _a	±0.5			±0.5			±1.0			±1.0			mV/°C
Overcurrent Protection Starting Current	I _{st}	1.6			1.6			1.6			1.6			A
	Conditions	V _{IN} =15V			V _{IN} =20V			V _{IN} =21V			V _{IN} =24V			
ON/OFF* Pin	Low Level Voltage	V _{SSL}			0.5			0.5			0.5			V
	Outflow Current at Low Voltage	I _{SSL}			100			100			100			
Quiescent Circuit Current	I _q	7			7			7			7			mA
		Conditions	V _{IN} =15V, I _o =0A			V _{IN} =20V, I _o =0A			V _{IN} =21V, I _o =0A			V _{IN} =24V, I _o =0A		
	I _{q(OFF)}	200			200			200			200			μA
		Conditions	V _{IN} =15V, V _{ON/OFF} =0.3V			V _{IN} =20V, V _{ON/OFF} =0.3V			V _{IN} =21V, V _{ON/OFF} =0.3V			V _{IN} =24V, V _{ON/OFF} =0.3V		

*: Pin 5 is the ON/OFF pin. Soft start at power on can be performed with a capacitor connected to this pin.
 The output can also be turned ON/OFF with this pin.
 The output is stopped by setting the voltage of this pin to V_{SSL} or lower.
 ON/OFF-pin voltage can be changed with an open-collector drive circuit of a transistor.
 When using both the soft-start and ON/OFF functions together, the discharge current from C₃ flows into the ON/OFF control transistor. Therefore, limit the current securely to protect the transistor if C₃ capacitance is large.
 The ON/OFF pin is pulled up to the power supply in the IC, so applying the external voltage is prohibited.

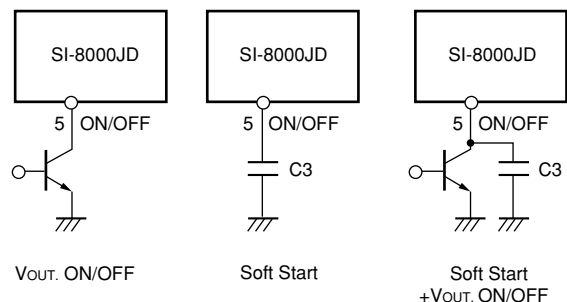

External Dimensions (TO263-5)

(Unit : mm)

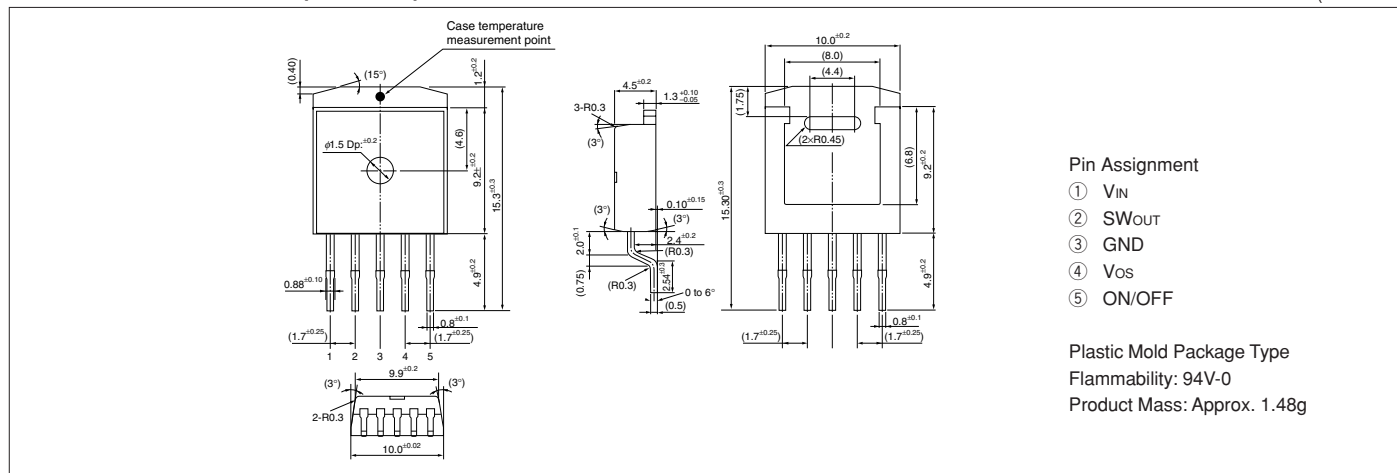

Block Diagram

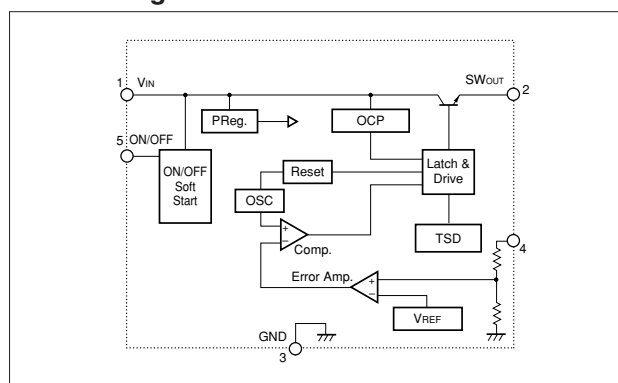

Typical Connection Diagram

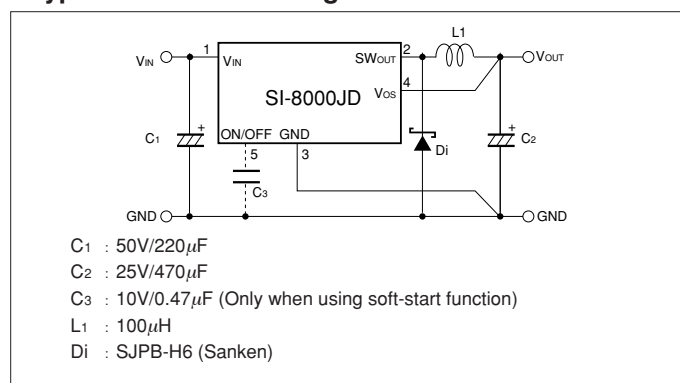

Reference Data

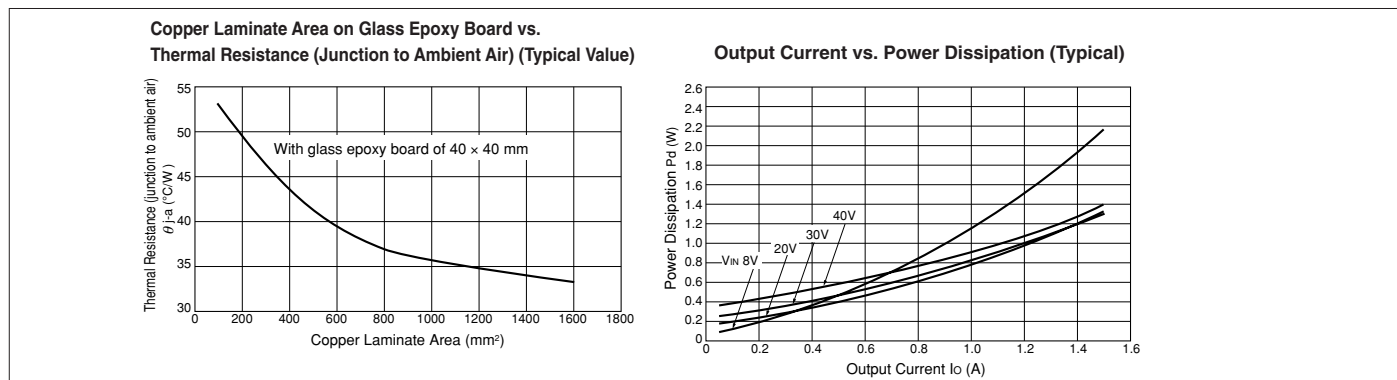

Ta-Pd Characteristics

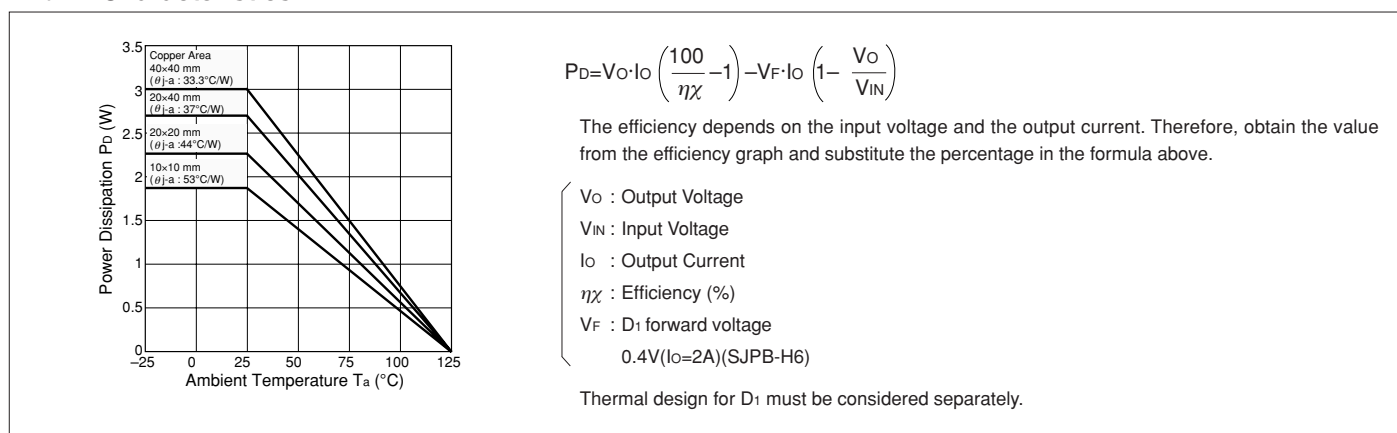

SI-8000TM Series Surface-Mount, Separate Excitation Step-down Switching Mode

Features

- Compact surface-mount package (TO252-5)
- Output current: 1.5 A
- High efficiency: 81% typ. (at $V_o = 5\text{ V}$)
- Requires only 4 discrete components
- Built-in reference oscillator (300 kHz)
- Built-in drooping-type-overcurrent and thermal protection circuits
- Output ON/OFF available (circuit current at output OFF: 200 μA typ.)
- Soft start available by ON/OFF pin

Applications

- Onboard local power supplies
- AV equipment
- OA equipment

Recommended Operating Conditions

Parameter	Symbol	Ratings		Unit
		SI-8008TM		
Input Voltage Range	V_{IN}	$V_o + 3^{*1}$ to 40		V
Output Voltage	V_o	0.8 to 24		V
Output Current Range	I_o	0 to 1.5		A
Operating Junction Temperature Range	T_{jop}	-20 to +100		$^{\circ}\text{C}$
Operating Temperature Range	T_{op}	-20 to +85		$^{\circ}\text{C}$

*1: The minimum value of an input voltage range is the higher of 4.5 V or $V_o + 3\text{ V}$.

Electrical Characteristics

($T_a = 25^{\circ}\text{C}$)

Parameter	Symbol	Rating			Unit
		SI-8008TM			
		min.	typ.	max.	
Reference Voltage	V_{ADJ}	0.784	0.800	0.816	V
	Conditions	$V_{IN} = 15\text{ V}, I_o = 0.1\text{ A}$			
Temperature Coefficient of Reference Voltage	$\Delta V_{ADJ}/\Delta T$		± 0.1		$\text{mV}/^{\circ}\text{C}$
	Conditions	$V_{IN} = 15\text{ V}, I_o = 0.1\text{ A}, T_c = 0\text{ to }100^{\circ}\text{C}$			
Efficiency	η		81		%
	Conditions	$V_{IN} = 15\text{ V}, I_o = 0.5\text{ A}$			
Oscillation Frequency	f_o		300		kHz
	Conditions	$V_{IN} = 15\text{ V}, I_o = 0.5\text{ A}$			
Line Regulation	ΔV_{OLINE}		60	80	mV
	Conditions	$V_{IN} = 10\text{ to }30\text{ V}, I_o = 0.5\text{ A}$			
Load Regulation	ΔV_{OLOAD}		10	40	mV
	Conditions	$V_{IN} = 15\text{ V}, I_o = 0.2\text{ to }1.5\text{ A}$			
Overcurrent Protection Starting Current	I_s	1.6			A
	Conditions	$V_{IN} = 15\text{ V}$			
ON/OFF Pin*	Low Level Voltage	V_{SSL}		0.5	V
	Outflow Current at Low Voltage	I_{SSL}	10	40	μA
	Conditions	$V_{SSL} = 0\text{ V}$			
Quiescent Circuit Current	I_q		6		mA
		Conditions	$V_{IN} = 15\text{ V}, I_o = 0\text{ A}$		
	$I_q(\text{OFF})$		200	400	μA
	Conditions	$V_{IN} = 15\text{ V}, V_{SS} = 0\text{ V}$			

*: Pin 5 is the SS pin. Soft start at power on can be performed with a capacitor connected to this pin. The output can also be turned ON/OFF with this pin. The output is stopped by setting the voltage of this pin to V_{SSL} or lower. SS-pin voltage can be changed with an open-collector drive circuit of a transistor. When using both the soft-start and ON/OFF functions together, the discharge current from C3 flows into the ON/OFF control transistor. Therefore, limit the current securely to protect the transistor if C3 capacitance is large. The SS pin is pulled up to the power supply in the IC, so applying the external voltage is prohibited. If the pin is not used, leave it open.

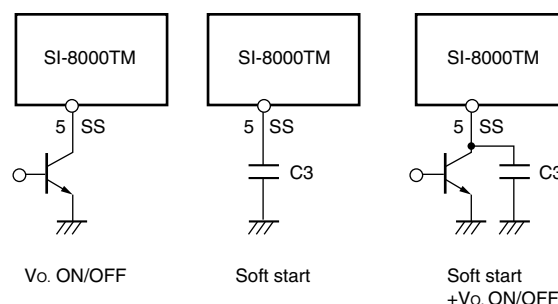

Vo. ON/OFF

Soft start

Soft start +Vo. ON/OFF

External Dimensions (TO252-5)

(Unit : mm)



Block Diagram

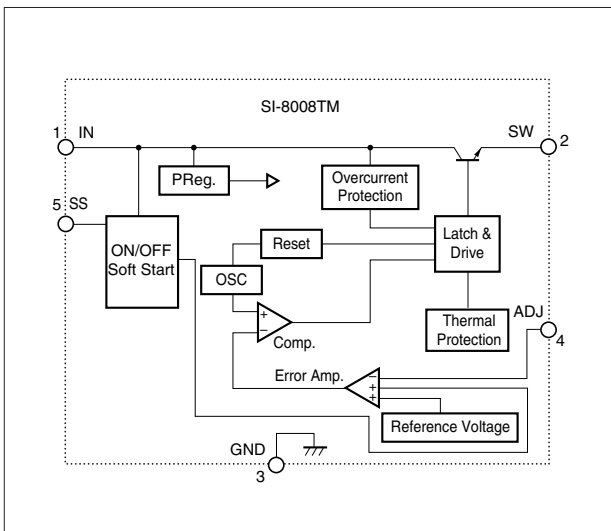

Typical Connection Diagram

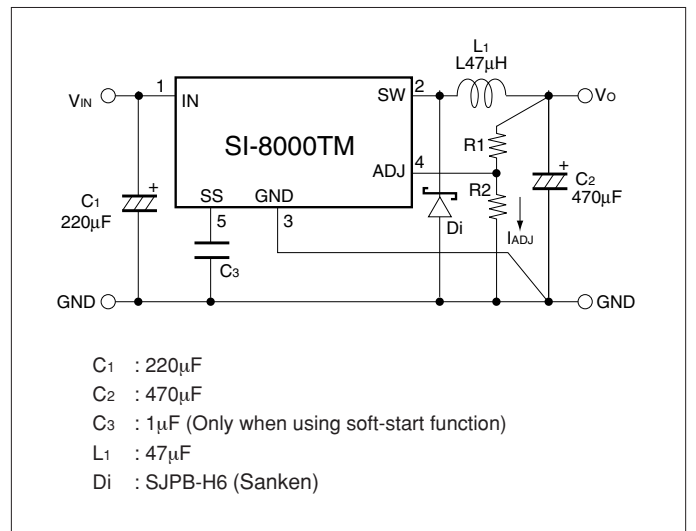

NR110E/K Surface-Mount, Current Mode Control Step-down Switching Mode

Features

- Compact surface-mount package
- Input voltage range (V_{IN}): $V_O + 3$ to 31 V
- Oscillation frequency: 30 kHz, 350 kHz, 364 kHz
- High efficiency under light load
- High efficiency: 94% or higher
- Current mode control
- Stable with low-ESR ceramic output capacitors
- Built-in phase compensation component
- Output current: 1.5 A, 2 A, 4 A
- Reference voltage and accuracy of $0.8 \text{ V} \pm 2\%$
- Overcurrent protection function that can be adjusted externally
- Output ON/OFF available
- Undervoltage lockout
- Soft start function

Applications

- Power supply for LCDTV, STB and Blu-Ray
- Power supplies for domestic appliances
- On-board local power supply
- Switching power supplies

Absolute Maximum Ratings

Parameter	Symbol	Ratings				Unit	Conditions
		NR110K	NR111E	NR117K	NR119E		
Input Voltage	V_{IN}	35	35	35	35	V	
BS Pin Voltage	V_{BS}	44	44	44	44	V	
Pin Voltage between BS and SW	V_{BS-SW}	8	8	8	8	V	
SW Pin Voltage	V_{SW}	35	35	35	35	V	
FB Pin Voltage	V_{FB}	5.5	5.5	5.5	5.5	V	
EN Pin Voltage	V_{EN}	35	35	35	35	V	
SS Pin Voltage	V_{SS}	5.5	5.5	5.5	5.5	V	
Power Dissipation	P_D	1.69	1.76	1.69	1.76	W	When mounted on $30 \times 30 \text{ mm}$ glass-epoxy board (with a $25 \times 25 \text{ mm}$ copper area)
Junction Temperature	T_J	-40 to 150	-40 to 150	-40 to 150	-40 to 150	$^{\circ}\text{C}$	
Storage Temperature	T_{stg}	-40 to 150	-40 to 150	-40 to 150	-40 to 150	$^{\circ}\text{C}$	
Thermal Resistance (Junction to Lead (4 pins))	θ_{J-C}	40	26	40	26	$^{\circ}\text{C}/\text{W}$	
Thermal Resistance (Junction to Ambient Air)	θ_{J-A}	74	71	74	71	$^{\circ}\text{C}/\text{W}$	When mounted on $30 \times 30 \text{ mm}$ glass-epoxy board (with a $25 \times 25 \text{ mm}$ copper area)

Recommended Operating Conditions

Parameter	Symbol	Ratings				Unit
		NR110K	NR111E	NR117K	NR119E	
Input Voltage Range	V_{IN}	8.0 or $V_O + 3^*$ to 31	6.5 or $V_O + 3^*$ to 31	8.0 or $V_O + 3^*$ to 31	6.5 or $V_O + 3^*$ to 31	V
Output Current Range	I_{OUT}	0 to 4.0**	0 to 4.0**	0 to 1.5**	0 to 2.0**	A
Output Voltage Range	V_O	0.8 to 24	0.8 to 24	0.8 to 24	0.8 to 24	V
Operating Temperature Range	T_{op}	-40 to 85**	-40 to 85**	-40 to 85**	-40 to 85**	$^{\circ}\text{C}$

*: The minimum value of the input voltage range is indicated value or $V_O + 3 \text{ V}$, whichever is higher.

** : The device must be used within the range indicated by the T_a -PD characteristics.

Electrical Characteristics

($T_a = 25^{\circ}\text{C}$, $V_{IN} = 12\text{V}$, $V_O = 5.0\text{V}$, and $I_O = 1\text{A}$, unless otherwise specified)

Parameter	Symbol	Ratings									Unit	Conditions	
		NR110K/NR111E			NR119E			NR117K					
		min.	typ.	max.	min.	typ.	max.	min.	typ.	max.			
Reference Voltage	V_{REF}	0.784	0.8000	0.816	0.784	0.8000	0.816	0.784	0.8000	0.816	V		
Temperature Coefficient of Reference Voltage	$\Delta V_{REF}/\Delta T$		± 0.05			± 0.05			± 0.05		$\text{mV}/^{\circ}\text{C}$	$T_a = -40^{\circ}\text{C}$ to $+85^{\circ}\text{C}$	
Oscillation Frequency	f_{sw}		350			364			30		kHz		
Line Regulation	V_{LINE}		50			50			50		mV	$V_{IN} = V_{INmin}$ to 30V	
Load Regulation	V_{Load}		50			50			50		mV	$V_{IN} = 12\text{V}$, $V_O = 5.0\text{V}$, $I_O = 0.1$ to I_{Omax}	
Overcurrent Protection	I_{s1}		1.5			0.9			0.3		A	ISET=OPEN	
Starting Current	I_{s2}		5.5			2.8			2.1		A	ISET=SHORT	
No-load Circuit Current	I_{IN}		1			1			1		mA	$V_{EN} = 10\text{k}\Omega$ pull up to V_{IN}	
Quiescent Circuit Current	$I_{IN(off)}$		1			1			1		μA	$I_O = 0\text{A}$, $V_{EN} = 0\text{V}$	
SS Pin	Outflow Current at Low Voltage	$I_{EN/SS}$	6	10	14	6	10	14	6	10	14	μA	$V_{SS} = 0\text{V}$
EN Pin	Inflow Current	I_{EN}		20	50		20	50		20	50	μA	$V_{EN} = 10\text{V}$
	On Threshold Voltage	$V_{C/EH}$	0.7	1.4	2.1	0.7	1.4	2.1	0.7	1.4	2.1	V	
ISET Pin	Open Voltage	V_{ISET}		1.5			1.5			1.5		V	
Maximum ON Duty	D_{MAX}		90			90			90		%		
Minimum ON Time	$T_{ON(MIN)}$			150			150			150		nsec	
Thermal Protection Start Temperature	TSD		151	165		151	165		151	165		$^{\circ}\text{C}$	
Thermal Protection Return Hysteresis	TSD_hys			20			20			20		$^{\circ}\text{C}$	
SW MOSFET ON Resistance	R_{onH}			85			150			150		$\text{m}\Omega$	

*: Pin 8 is the SS pin. Soft start at power on can be performed with a capacitor connected to this pin. The SS pin is pulled up to the power supply in the IC, so applying the external voltage is prohibited.

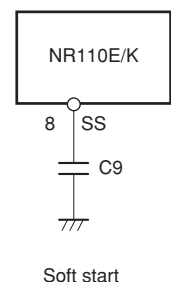

External Dimensions

(Unit : mm)

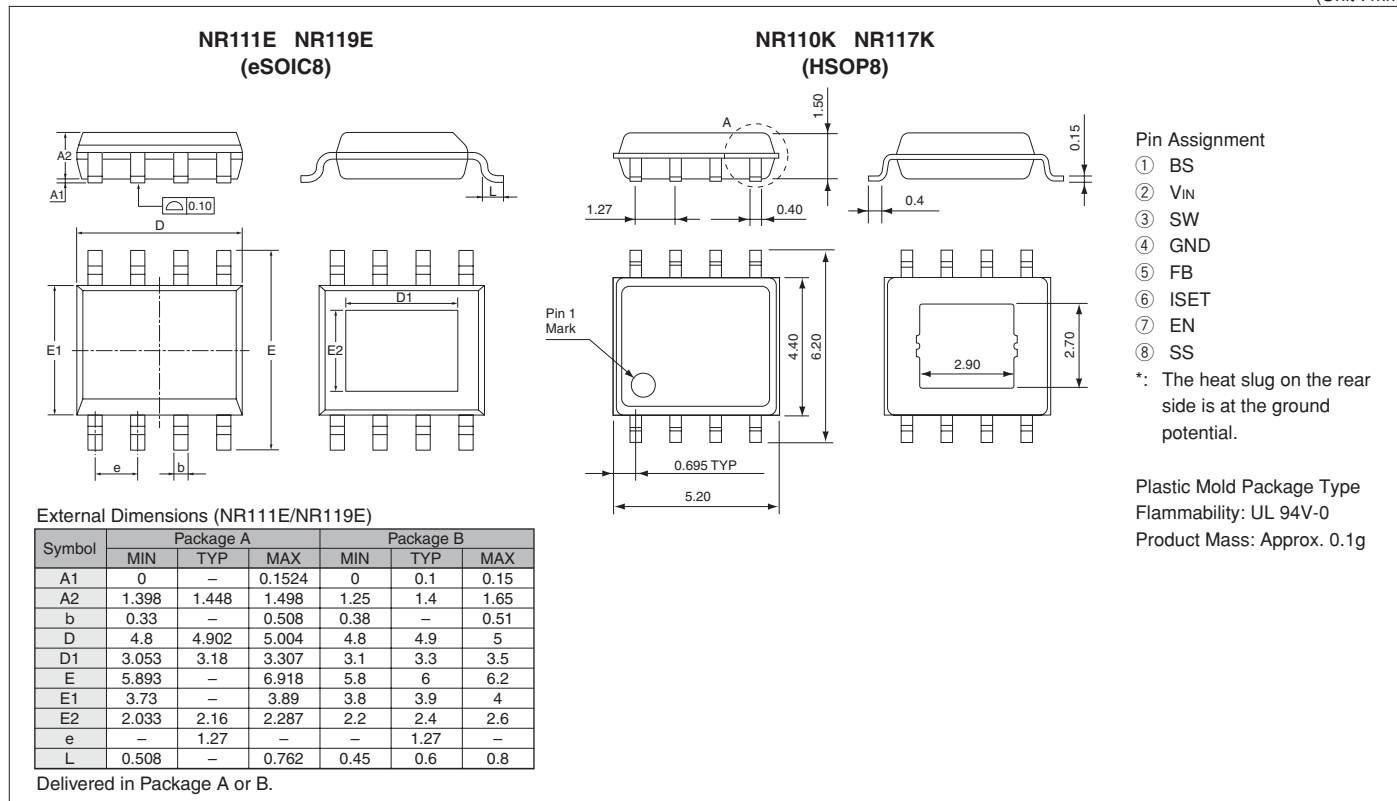

Block Diagram

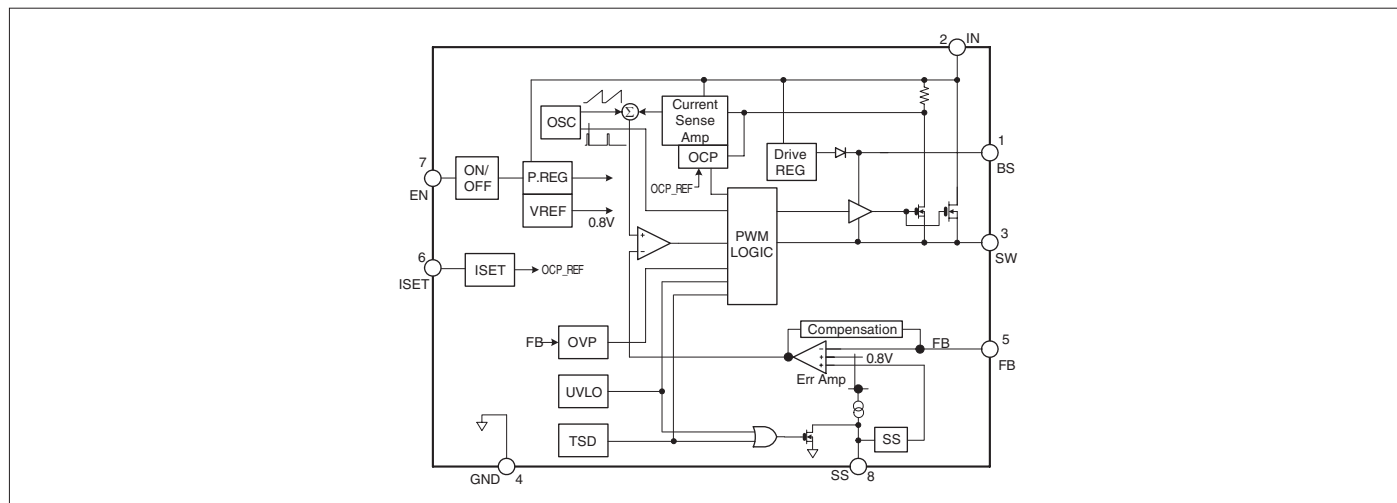

Typical Connection Diagram

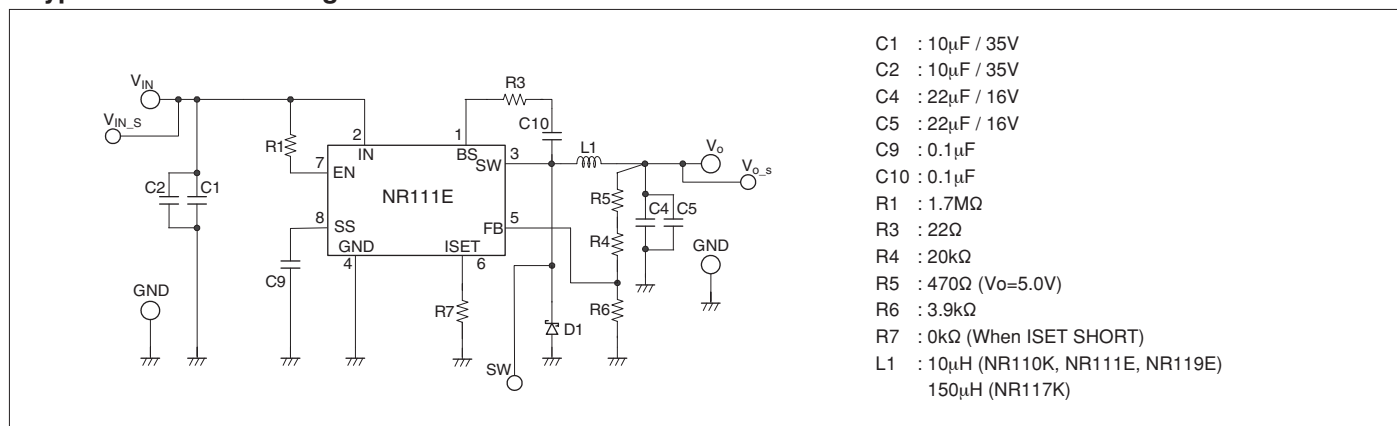

NR885K/NR885E Surface-Mount, Current Mode Control, Synchronous Rectifier Step-down Switching Mode

Features

- Compact surface-mount package
- Input voltage range (V_{IN}): $V_O + 3$ to 18 V
- Synchronous rectifier mode
- High efficiency: 90%
- Current mode control
- Stable with low-ESR ceramic output capacitors
- Built-in phase compensation component
- Output current: 3 A
- Reference voltage and accuracy of $0.8\text{ V} \pm 2\%$
- Oscillation frequency: 350 kHz
- Output ON/OFF available
- Undervoltage lockout
- Soft start function

Applications

- Power supply for LCDTV and PDP
- Power supply for DVD, BD, and STB
- On-board local power supply
- Switching power supplies

Absolute Maximum Ratings

Parameter	Symbol	Ratings		Unit	Conditions
		NR885K	NR885E		
Input Voltage	V_{IN}	20	20	V	
Power Dissipation	P_D	1.69	1.50	W	When mounted on 70×60 mm glass-epoxy board (with a 1310 mm^2 copper area)
Junction Temperature	T_J	-40 to +150	-40 to +150	$^{\circ}\text{C}$	
Storage Temperature	T_{stg}	-40 to +150	-40 to +150	$^{\circ}\text{C}$	
Thermal Resistance (Junction to Lead (4 pins))	θ_{j-c}	40	26	$^{\circ}\text{C/W}$	
Thermal Resistance (Junction to Ambient Air)	θ_{j-a}	74	71	$^{\circ}\text{C/W}$	When mounted on 70×60 mm glass-epoxy board (with a 1310 mm^2 copper area)

Recommended Operating Conditions

Parameter	Symbol	Ratings	Unit
Input Voltage Range	V_{IN}	4.5 or $V_O + 3^*$ to 18	V
Output Current Range	I_O	0 to 3.0	A
Output Voltage Range	V_O	0.8 to 14	V
Operating Temperature Range	T_{OP}	-40 to +85	$^{\circ}\text{C}$

*: The minimum value of the input voltage range is 4.5 V or $V_O + 3$ V, whichever is higher.

Electrical Characteristics

($T_a=25^{\circ}\text{C}$, $V_{IN}=12\text{V}$, $V_O=3.3\text{V}$, and $I_O=1\text{A}$, unless otherwise specified)

Parameter	Symbol	Ratings			Unit	Conditions
		min.	typ.	max.		
Reference Voltage	V_{REF}	0.784	0.800	0.816	V	
Temperature Coefficient of Reference Voltage	$\Delta V_{REF}/\Delta T$		± 0.05		mV/ $^{\circ}\text{C}$	$T_a=-40^{\circ}\text{C}$ to $+85^{\circ}\text{C}$
Efficiency	η		90		%	
Oscillation Frequency	f_o	280	350	420	kHz	
Line Regulation	V_{LINE}		50		mV	$V_{IN}=6.3\text{V}$ to 18V
Load Regulation	V_{Load}		50		mV	$I_O=0.1\text{A}$ to 3A
Overcurrent Protection Starting Current	I_S	3.1		6.0	A	
Quiescent Circuit Current 1	I_{IN}		6		mA	$V_{EN}=10\text{k}\Omega$ pull up to V_{IN}
Quiescent Circuit Current 2	$I_{IN(off)}$	0		10	μA	$I_O=0\text{A}$, $V_{EN}=0\text{V}$
SS Pin	Outflow Current at Low Voltage	$I_{EN/SS}$	6	10	μA	$V_{SS}=0\text{V}$
	Open Voltage	V_{SSH}		3.0	V	
EN Pin	Inflow Current	I_{EN}		50	μA	$V_{EN}=10\text{V}$
	On Threshold Voltage	$V_{C/EH}$	0.7	1.4	2.1	V
Maximum ON Duty	$DMAX$		90		%	
Minimum ON Time	$DMIN$		150		nsec	
Thermal Protection Start Temperature	TSD	151	165		$^{\circ}\text{C}$	
Thermal Protection Return Hysteresis	TSD_{hys}		20		$^{\circ}\text{C}$	

*: Pin 8 is the SS pin. Soft start at power on can be performed with a capacitor connected to this pin. The SS pin is pulled up to the power supply in the IC, so applying the external voltage is prohibited.

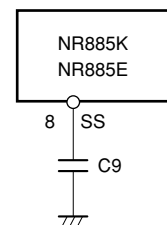

External Dimensions

(Unit : mm)

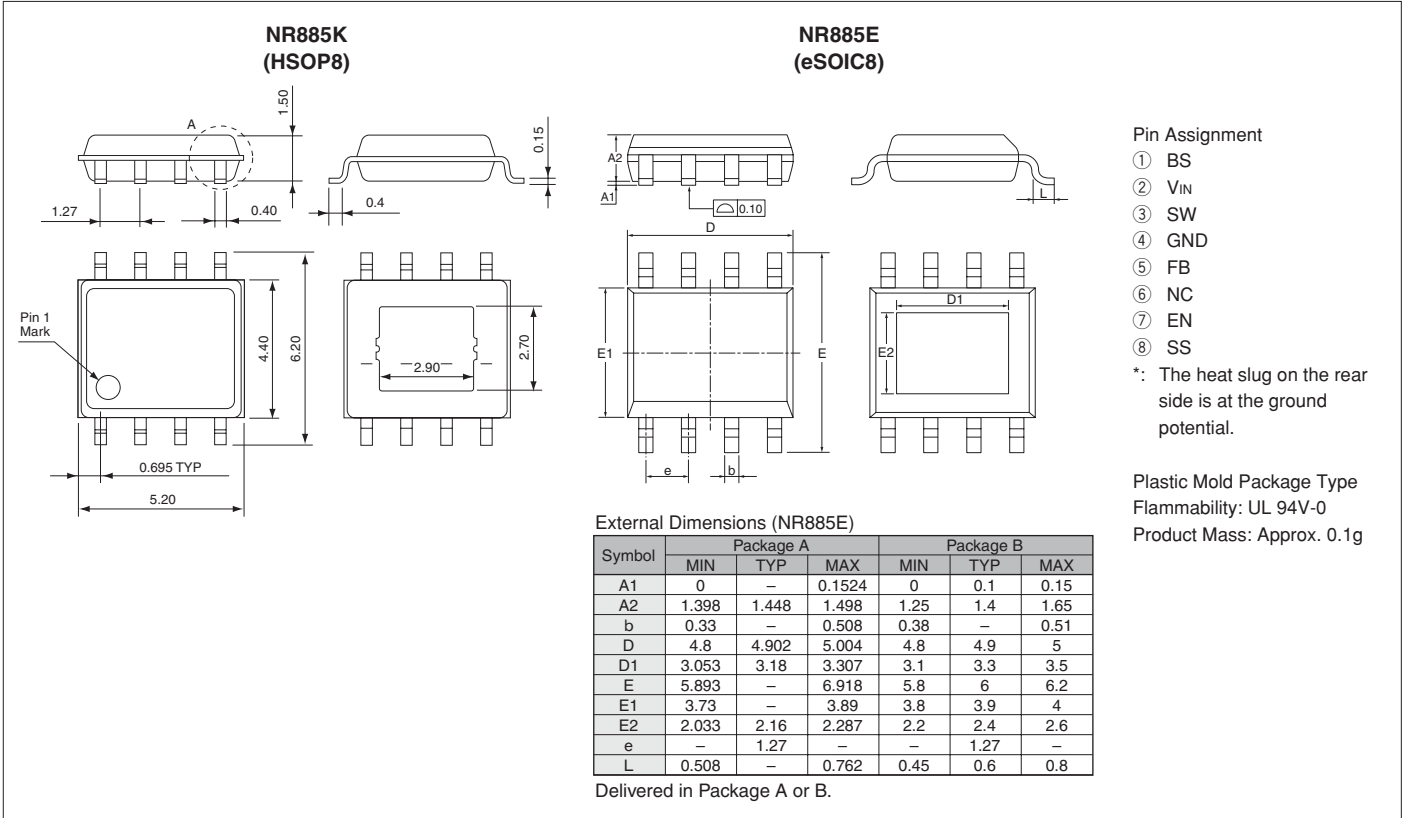

Block Diagram



Typical Connection Diagram

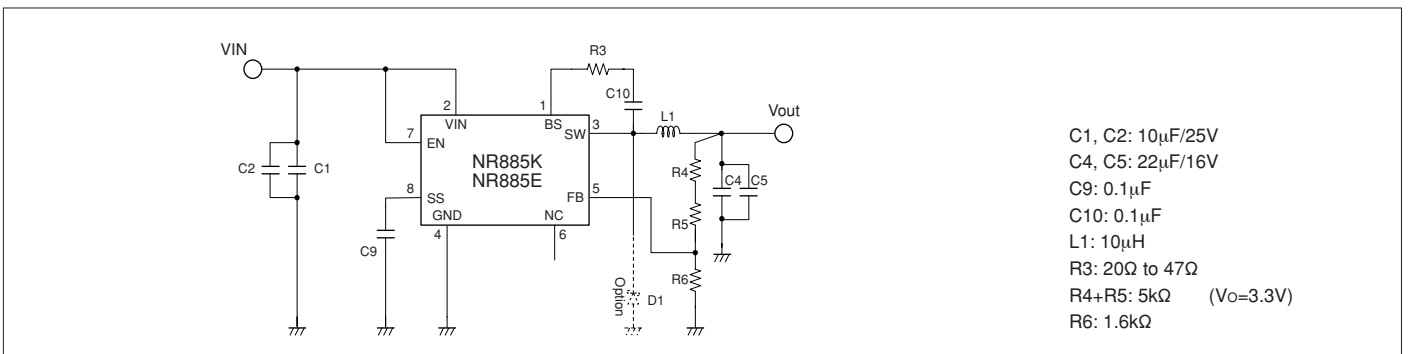

SI-8205NHD/SI-8205NHG

Surface-Mount, Current Mode Control, Synchronous Rectifier Step-down Switching Mode

■ Features

- Compact surface-mount (HSOP8) package
- Wide input voltage range (V_{IN}): $V_o + 3$ to 43 V
- Synchronous rectifier mode
- Output current: 3 A
- Reference voltage and accuracy of $0.5\text{ V} \pm 1\%$
- Oscillation frequency
SI-8205NHD
Externally adjusted frequency type: 200 kHz to 1 MHz
SI-8205NHG
Externally synchronized frequency type: 300 kHz to 1 MHz
- Stable with low-ESR ceramic output capacitors
- Output can be disabled
- Undervoltage lockout
- Soft start function

■ Applications

- Power supply for LCD module
- Power supply for notebook PC
- Onboard local power supplies
- Power supply for LBP/PPC

■ Absolute Maximum Ratings

Parameter	Symbol	Ratings		Unit	Conditions
		SI-8205NHD	SI-8205NHG		
Input Voltage (V_{IN} Pin)	V_{IN}	46	46	V	
SYNC Pin Voltage	V_{SYNC}	–	5.5	V	
Power Dissipation	P_D	1.35	1.35	W	When mounted on a 30 × 30 mm glass-epoxy board (with a 25 × 25 mm copper area)
Junction Temperature	T_j	–40 to +150	–40 to +150	°C	
Storage Temperature	T_{stg}	–40 to +150	–40 to +150	°C	
Thermal Resistance (Junction to Lead <1 pin>)	θ_{j-c}	40	40	°C/W	
Thermal Resistance (Junction to Ambient Air)	θ_{j-a}	74	74	°C/W	When mounted on a 30 × 30 mm glass-epoxy board (with a 25 × 25 mm copper area)

■ Recommended Operating Conditions

Parameter	Symbol	Ratings		Unit
		SI-8205NHD	SI-8205NHG	
Input Voltage Range	V_{IN}	8 or $V_o + 3^*$ to 43	7 or $V_o + 3^*$ to 43	V
SYNC Pin Voltage Range	V_{SYNC}	–	0 to 5	V
Output Current Range	I_{out}	0 to 3.0	0 to 3.0	A
Output Voltage Range	V_o	0.5 to 24	0.5 to 24	V
Externally Synchronized Frequency Range	f_{SYNC}	–	300 to 1000	kHz
Operating Temperature Range	T_{op}	–40 to +85	–40 to +85	°C

*: The minimum value of the input voltage range is 8 V or $V_o + 3V$, whichever is higher.

■ Electrical Characteristics

($T_a = 25^\circ\text{C}$ and $f_o = 500\text{kHz}$, unless otherwise specified)

Parameter	Symbol	Ratings						Unit	
		SI-8205NHD			SI-8205NHG				
		min.	typ.	max.	min.	typ.	max.		
Reference Voltage	V_{REF}	0.495	0.5000	0.505	0.495	0.5000	0.505	V	
Conditions		$V_{IN}=12V, I_o=1.0A$			$V_{IN}=14V, I_o=1.0A$				
Temperature Coefficient of Reference Voltage	$\Delta V_{REF}/\Delta T$		± 0.05			± 0.05		mV/°C	
Conditions		$V_{IN}=12V, I_o=1.0A, T_a=-40$ to $+85^\circ\text{C}$			$V_{IN}=14V, I_o=1.0A, T_a=-40$ to $+85^\circ\text{C}$				
Efficiency	η		90			90		%	
Conditions		$V_{IN}=12V, V_o=5V, I_o=1.0A$			$V_{IN}=14V, V_o=5V, I_o=1.0A$				
Oscillation Frequency 1	f_{o1}		200			–		kHz	
Conditions		$V_{IN}=12V, V_o=5V, I_o=1A, Rfset=375k\Omega$			–				
Oscillation Frequency 2	f_{o2}		1			–		MHz	
Conditions		$V_{IN}=12V, V_o=5V, I_o=1A, Rfset=75k\Omega$			–				
Internal Oscillation Frequency	f_o		–			250		kHz	
Conditions		–			$V_{IN}=14V, V_o=5V, I_o=1.0A, SYNC=GND$				
Line Regulation	ΔV_{oLINE}		50			50		mV	
Conditions		$V_{IN}=8$ to $43V, V_o=5V, I_o=1A$			$V_{IN}=8$ to $43V, V_o=5V, I_o=1A$				
Load Regulation	ΔV_{oLoad}		50			50		mV	
Conditions		$V_{IN}=12V, V_o=5V, I_o=0.1$ to $3.0A$			$V_{IN}=12V, V_o=5V, I_o=0.1$ to $3.0A$				
Overcurrent Protection Starting Current	I_s	3.1		6	3.1		6	A	
Conditions		$V_{IN}=12V, V_o=5V$			$V_{IN}=14V, V_o=5V$				
Quiescent Circuit Current 1	I_{IN}		8			12		mA	
Conditions		$V_{IN}=12V, V_{comp}=0V$			$V_{IN}=14V, V_{comp}=0V$				
Quiescent Circuit Current 2	$I_{IN(off)}$			40			35	μA	
Conditions		$V_{IN}=12V, V_{EN/SS}=0V$			$V_{IN}=14V, V_{EN/SS}=0V$				
EN/SS Pin	Outflow Current at Low Voltage	$I_{EN/SS}$	5			5		μA	
		Conditions	$V_{EN/SS}=0V, V_{IN}=12V$			$V_{EN/SS}=0V, V_{IN}=12V$			
	Open Voltage	V_{SSH}	3	4.5	6	3	4.5	6	V
		Conditions	$V_{IN}=12V$			$V_{IN}=14V$			
On Threshold Voltage	$V_{C/EH}$	0.6	1.3	2.0	0.6	1.3	2.0	V	
	Conditions	$V_{IN}=12V$			$V_{IN}=14V$				
SYNC Pin	Synchronization Threshold Voltage	V_{SYNC}		–		1.85		V	
		Conditions	–			$V_{IN}=14V, V_o=5V, I_o=1.0A$			
Synchronization Frequency	f_{SYNC}		–		300		1000.0	kHz	
	Conditions	–			$V_{IN}=14V, V_o=5V, I_o=1.0A$				
OVP Start Voltage	V_{ovp}	0.57	0.60	0.63		–		V	
Thermal Protection Start Temperature	T_j	151	160		151	160		°C	
Error Amplifier Voltage Gain	AEA		800			800		V/V	
Error Amplifier Transformer Conductance	GEA		800			800		$\mu\text{A}/V$	
Current Sense Amplifier Impedance	GCS		3.33			3.33		A/V	
Maximum ON Duty	$DMAX$	80	90			90		%	
	Conditions	$V_{IN}=12V$			$V_{IN}=12V$				
Minimum ON Time	$DMIN$		150			250		nsec	
	Conditions	$V_{IN}=12V$			$V_{IN}=12V$				

External Dimensions (HSOP8)

(Unit : mm)



Pin Assignment

SI-8205NHD	SI-8205NHG
① GND	① GND
② EN/SS	② EN/SS
③ VIN	③ VIN
④ FSET	④ SYNC
⑤ COMP	⑤ COMP
⑥ FB	⑥ FB
⑦ BS	⑦ BS
⑧ SW	⑧ SW

*: The heat slug on the rear side is at the ground potential.

Plastic Mold Package Type
 Flammability : UL 94V-0
 Product Mass : Approx. 0.1 g

Block Diagram

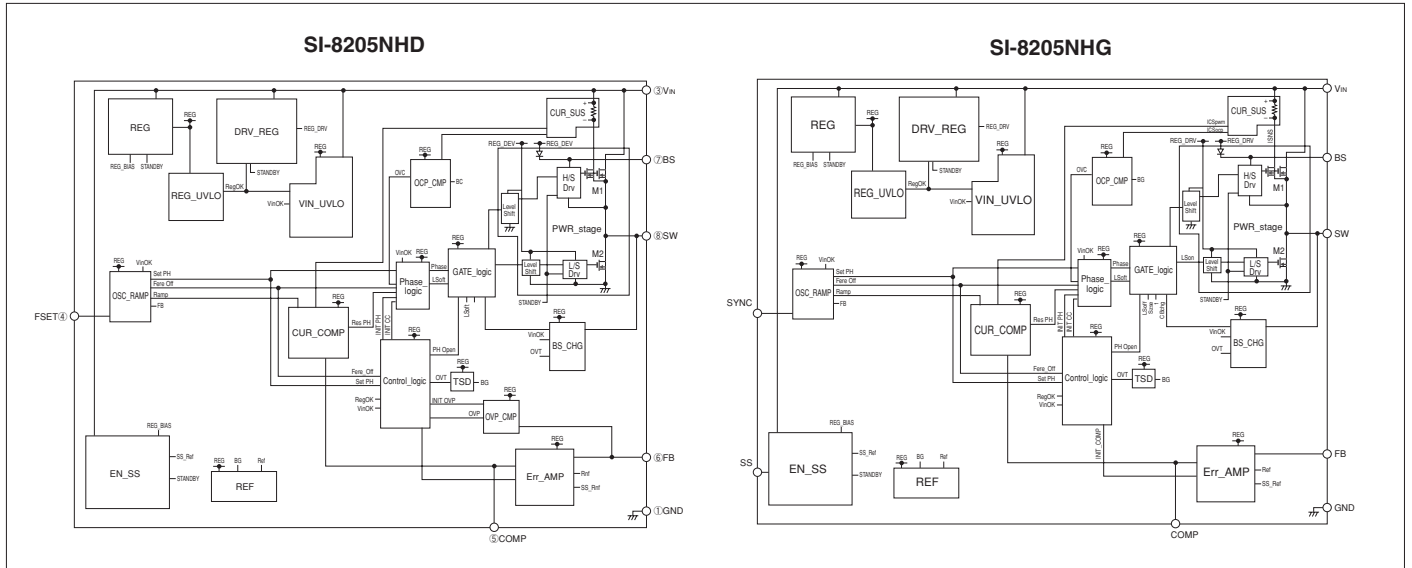

Typical Connection Diagram

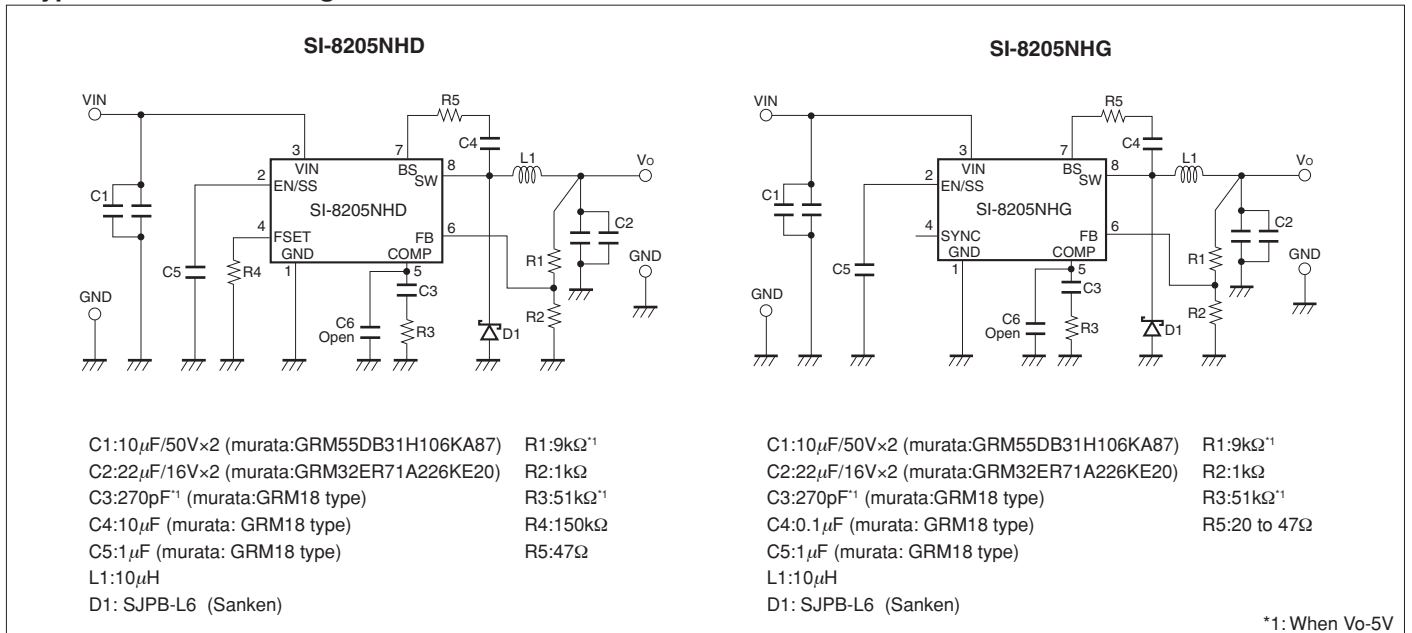

SI-8000SD Series Surface Mount, Separate Excitation Step-down Switching Mode

Features

- Surface-mount package (TO263-5)
- Output current: 3.0A
- High efficiency: 79% typ. (SI-8033SD), 84% typ. (SI-8050SD)
- Requires only 4 discrete external components
- Internally-adjusted phase compensation and output voltage
- Built-in reference oscillator (60kHz)
- Built-in overcurrent and thermal protection circuits
- Output ON/OFF available
- Soft start available by S.S pin

Lineup

Part Number	SI-8033SD	SI-8050SD
Vo (V)	3.3	5.0
Io (A)	3	

Absolute Maximum Ratings

Parameter	Symbol	Ratings	Unit	Conditions
DC Input Voltage	V _{IN}	43*1	V	
Power Dissipation*2	P _D	3	W	When mounted on glass-epoxy board 40 x 40 mm (copper area: 100%)
Junction Temperature	T _j	+125	°C	
Storage Temperature	T _{stg}	-40 to +125	°C	
Thermal Resistance (Junction to Case)	θ _{J-C}	3	°C/W	
Thermal Resistance (Junction to Ambient Air)	θ _{J-A}	33.3	°C/W	When mounted on glass-epoxy board 40 x 40 mm (copper area: 100%)

*1: 35V for SI-8033SD

*2: Limited by thermal protection circuit.

Applications

- Power supplies for telecommunication equipment
- Onboard local power supplies

Recommended Operating Conditions

Parameter	Symbol	Ratings		Unit
		SI-8033SD	SI-8050SD	
DC Input Voltage Range	V _{IN1}	5.5 to 28	7 to 40	V
Output Current Range*	I _O	0 to 3.0		A
Operating Junction Temperature Range	T _{jop}	-30 to +125		°C
Operating Temperature Range*	T _{op}	-30 to +125		°C

*: Limited by Ta-Pd characteristics.

Electrical Characteristics

(T_a=25°C)

Parameter	Symbol	Ratings						Unit	
		SI-8033SD			SI-8050SD				
		min.	typ.	max.	min.	typ.	max.		
Output Voltage	V _O	3.17	3.3	3.43	4.8	5.0	5.2	V	
	Conditions	V _{IN} =15V, I _O =1A			V _{IN} =20V, I _O =1A				
Efficiency	η		79			84		%	
	Conditions	V _{IN} =15V, I _O =1A			V _{IN} =20V, I _O =1A				
Oscillation Frequency	f		60			60		kHz	
	Conditions	V _{IN} =15V, I _O =1A			V _{IN} =20V, I _O =1A				
Line Regulation	ΔV _{OLINE}		25	80		40	100	mV	
	Conditions	V _{IN} =8 to 28V, I _O =1A			V _{IN} =10 to 30V, I _O =1A				
Load Regulation	ΔV _{OLOAD}		10	30		10	40	mV	
	Conditions	V _{IN} =15V, I _O =0.5 to 1.5A			V _{IN} =20V, I _O =0.5 to 1.5A				
Temperature Coefficient of Output Voltage	ΔV _O /ΔT _a		±0.5			±0.5		mV/°C	
Overcurrent Protection Starting Current	I _{S1}	3.1			3.1			A	
	Conditions	V _{IN} =15V			V _{IN} =20V				
Soft Start Pin*	Low-Level Voltage	V _{SSL}	0.2			0.2		V	
	Outflow Current at Low Voltage	I _{SSL}	20	30	40	20	30		40
		Conditions	V _{SSL} =0.2V						μA

* Pin 5 is a soft start pin. Soft start at power on can be performed with a capacitor connected to this pin.

The output can also be turned ON/OFF with this pin.

The output is stopped by setting the voltage of this pin to V_{SSL} or lower.

Soft-start pin voltage can be changed with an open-collector drive circuit of a transistor.

When using both the soft-start and ON/OFF functions together, the discharge current from C₃ flows into the ON/OFF control transistor. Therefore, limit the current securely to protect the transistor if C₃ capacitance is large.

The ON/OFF pin is pulled up to the power supply in the IC, so applying the external voltage is prohibited.

If this pin is not used, leave it open.



External Dimensions (TO263-5)

(Unit : mm)



Block Diagram

Reference Data

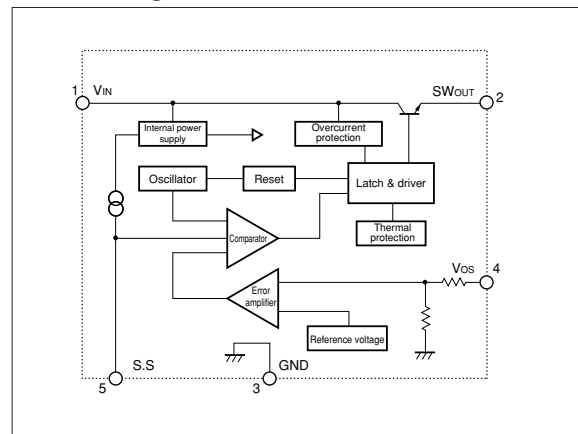

Typical Connection Diagram

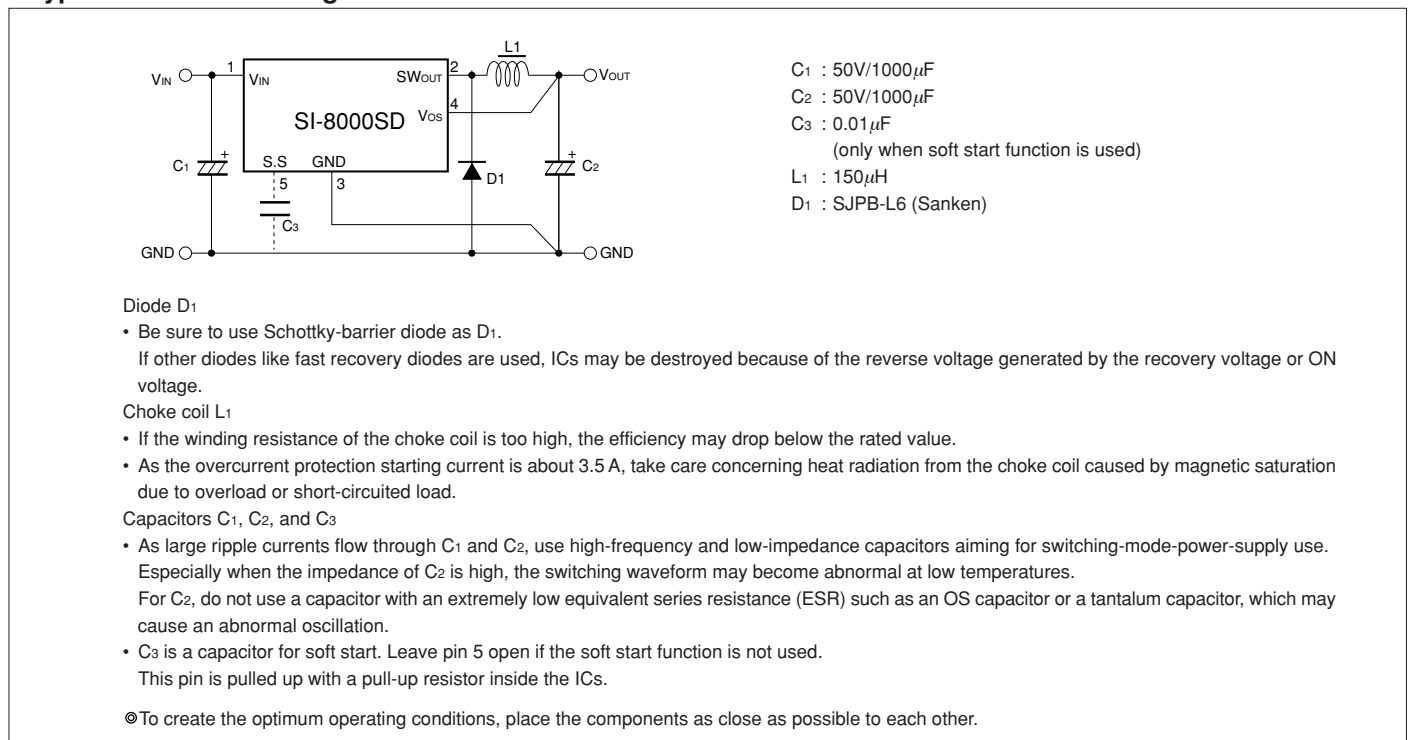

SPI-8000A Series Surface Mount, Separate Excitation Step-down Switching Mode

Features

- Surface-mount 16 pin package
- Output current: 3.0A
- High efficiency: 91% (at $V_{IN} = 10V$, $I_o = 1A$, $V_o = 5V$)
- Capable of downsizing a choke-coil due to IC's high switching frequency (250kHz). (Compared with conventional Sanken devices)
- The output-voltage-variable type can vary its output voltage from 1V to 14V because of its low reference voltage (V_{ref}) of 1V.
- Wide Input Voltage Range (8 to 50V)
- Output ON/OFF available
- Built-in overcurrent and thermal protection circuits

Absolute Maximum Ratings

($T_a=25^\circ C$)

Parameter	Symbol	Ratings	Unit
DC Input Voltage	V_{IN}	53	V
Power Dissipation	$P_D^{*1, *2}$	2.4	W
Junction Temperature	T_j	+125	$^\circ C$
Storage Temperature	T_{stg}	-40 to +125	$^\circ C$
Thermal Resistance (junction to case)	θ_{j-c}^{*2}	18	$^\circ C/W$
Thermal Resistance (junction to ambient air)	θ_{j-a}^{*2}	50	$^\circ C/W$

*1: Limited due to thermal protection.

*2: When mounted on glass-epoxy board 700cm² (copper laminate area 30.8cm²).

Applications

- Onboard local power supplies
- OA equipment
- For stabilization of the secondary-side output voltage of switching power supplies

Recommended Operating Conditions

Parameter	Symbol	Ratings		Unit
		SPI-8010A		
DC Input Voltage Range	V_{IN}	(8 or V_o+3) ^{*1} to 50		V
Output Voltage Range	V_o	1 to 14		V
Output Current Range ^{*2}	I_o	0.02 to 3.0 ^{*2}		A
Operating Junction Temperature Range	T_{jop}	-30 to +125		$^\circ C$
Operating Temperature Range	T_{op}	-30 to +125		$^\circ C$

*1: The minimum value of an input voltage range is the higher of either 8V or V_o+3V .

*2: Please be sure to let the output current run more than 20 mA. When using by less than 20 mA, there is a possibility that the output voltage becomes unstable.

Electrical Characteristics

($T_a=25^\circ C$)

Parameter	Symbol	Ratings			Unit
		SPI-8010A (Variable type)			
		min.	typ.	max.	
Reference Voltage	V_{REF}	0.97	1.00	1.03	V
	Conditions	$V_{IN}=12V, I_o=1A$			
Efficiency	Eff		86		%
	Conditions	$V_{IN}=20V, I_o=1A, V_o=5V$			
Oscillation Frequency	F_{OSC}		250		kHz
	Conditions	$V_{IN}=12V, I_o=1A$			
Line Regulation	ΔV_{OLINE}		20	40	mV
	Conditions	$V_{IN}=10$ to $30V, I_o=1A$			
Load Regulation	ΔV_{OLOAD}		10	30	mV
	Conditions	$V_{IN}=12V, I_o=0.1$ to $1.5A$			
Temperature Coefficient of Reference Voltage	$\Delta V_{REF}/\Delta T_a$		± 0.5		mV/ $^\circ C$
Overcurrent Protection Starting Current	I_s	3.1			A
	Conditions	$V_{IN}=12V$			
Quiescent Circuit Current	I_q		7		mA
	Conditions	$V_{IN}=12V, I_o=0A$			
Circuit Current at Output OFF	$I_{q(off)}$			400	μA
	Conditions	$V_{IN}=12V, V_{ON/OFF}=0.3V$			
CE/SS Terminal	Low Level Voltage	V_{SSL}		0.5	V
	Outflow Current at Low Voltage	I_{SSL}		50	μA
	Conditions	$V_{SSL}=0V$			

* Pin 4 is the CE/SS pin. Soft start at power on can be performed with a capacitor connected to this pin. The output can also be turned ON/OFF with this pin. The output is stopped by setting the voltage of this pin to V_{SSL} or lower. CE/SS-pin voltage can be changed with an open-collector drive circuit of a transistor. When using both the soft-start and ON/OFF functions together, the discharge current from C4 flows into the ON/OFF control transistor. Therefore, limit the current securely to protect the transistor if C3 capacitance is large. The CE/SS pin is pulled up to the power supply in the IC, so applying the external voltage is prohibited.



External Dimensions (HSOP16)

(Unit : mm)

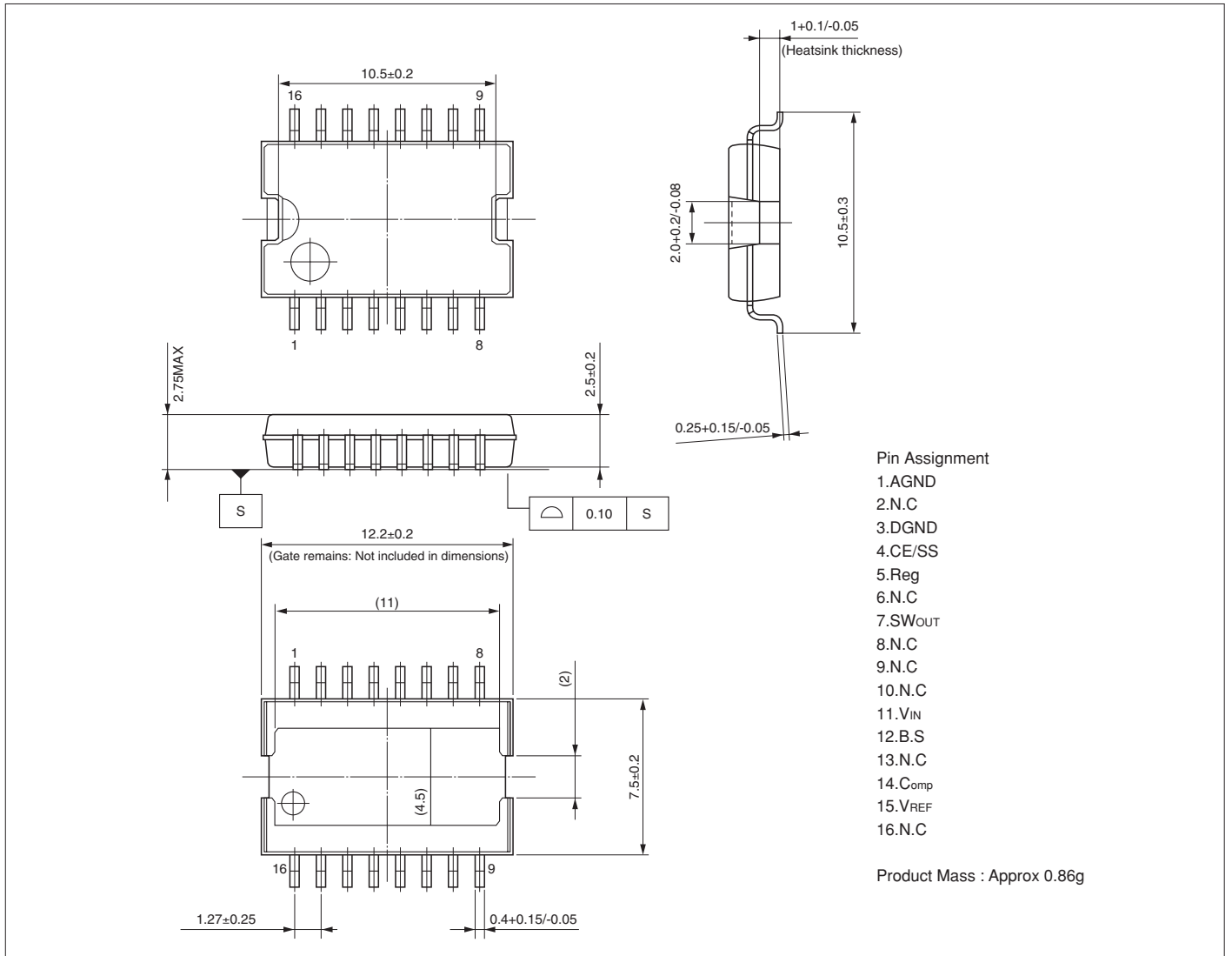

Block Diagram

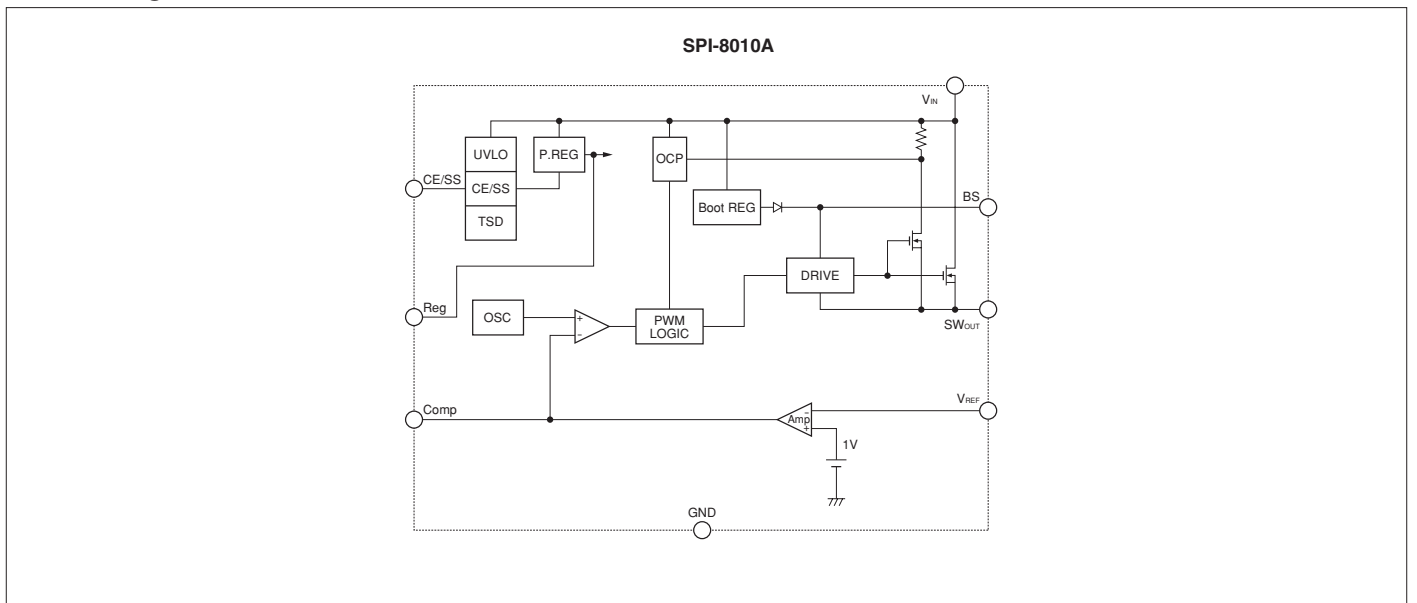

■ Typical Connection Diagram

C1: 220 μ F/63V
 C2: 470 μ F/25V
 C3: 0.1 μ F
 C4: 1000pF
 C5: 0.1 μ F
 C6: 0.047 μ F
 C7: 0.1 μ F
 C8: 0.1 μ F
 R1: 47 Ω
 L1: 47 μ H
 D1: SJPB-L6
 (Sanken)

Diode D1

- Be sure to use a Schottky-barrier diode for D1. If other diodes like fast recovery diodes are used, ICs may be destroyed because of the reverse voltage generated by the recovery voltage or ON voltage.

Choke coil L1

- If the winding resistance of the choke coil is too high, the efficiency may drop below the rated value.
- As the overcurrent protection starting current is about 4.5A, take care concerning heat radiation from the choke coil caused by magnetic saturation due to overload or short-circuited load.

Capacitors C1, C2

- As large ripple currents flow through C1 and C2, use high-frequency and low-impedance capacitors aiming for switching-mode-power-supply use. Especially when the impedance of C2 is high, the switching waveform may become abnormal at low temperatures. For C2, do not use a capacitor with an extremely low equivalent series resistance (ESR) such as an OS capacitor or a tantalum capacitor, which may cause an abnormal oscillation.

Resistors R2, R3

- R2 and R3 are the resistors to set the output voltage. Set their values so that IREF becomes approx. 2mA. Obtain R2 and R3 values by the following formula:

$$R2 = \frac{(V_{OUT} - V_{REF})}{I_{REF}} = \frac{(V_{OUT} - 1)}{2 \times 10^{-3}} (\Omega), R3 = \frac{V_{REF}}{I_{REF}} = \frac{1}{2 \times 10^{-3}} \approx 500 (\Omega)$$

©To create the optimum operating conditions, place the components as close as possible to each other.

■ Ta-Pd Characteristics

$$P_D = V_O \cdot I_O \left(\frac{100}{\eta\%} - 1 \right) - V_F \cdot I_O \left(1 - \frac{V_O}{V_{IN}} \right)$$

Note 1: The efficiency depends on the input voltage and the output current. Therefore, obtain the value from the efficiency graph and substitute the percentage in the formula above.

Note 2: Thermal design for D1 must be considered separately.

V_O : Output voltage
 V_{IN} : Input voltage
 I_O : Output current
 η% : Efficiency (%)
 V_F : Diode D1 forward voltage

SI-8000Q Series Surface Mount, Current Mode Control Step-down Switching Mode

■ Features

- Compact surface-mount package (HSOP8)
- Introduction of current mode control method
- Output current: 3.5 A
- High efficiency: 90% ($V_o = 5\text{ V}$)
- Built-in reference oscillator (500 kHz)
- A ceramic capacitor can be used for output
- Built-in drooping-type overcurrent and thermal protection circuits
- Built-in soft start circuit
- Built-in on/off function (Active Hi)
- Low current consumption during off

■ Absolute Maximum Ratings

Parameter	Symbol	Ratings	Unit	Conditions
Input Voltage	V_{IN}	30	V	
Power Dissipation ^{*1}	P_D	1.35	W	When mounted on glass-epoxy board, 30×30 mm (copper laminate area: 25×25 mm)
Junction Temperature ^{*2}	T_j	-30 to +150	°C	
Storage Temperature	T_{stg}	-40 to +150	°C	
Thermal Resistance(junction to case)	θ_{j-c}	40	°C/W	
Thermal Resistance(junction to ambient air)	θ_{j-a}	74	°C/W	When mounted on glass-epoxy board, 30×30 mm (copper laminate area: 25×25 mm)

*1: Limited by thermal protection circuit

*2: Note that the detection temperature for thermal protection is about 140°C.

■ Applications

- DVD recorder, FPD-TV
- Onboard local power supplies
- OA equipment

■ Recommended Operating Conditions

Parameter	Symbol	Ratings		Unit	Conditions
		SI-8005Q			
DC Input Voltage Range	V_{IN}	$V_o + 3^{*1}$ to 28		V	
Output Voltage Range	V_o	0.5 to 24		V	
Output Current Range	I_o	0 to 3.5		A	
Operating Junction Temperature Range	T_{jop}	-30 to +125		°C	
Operating Temperature Range	T_{op}	-30 to +85		°C	

*1: The minimum value of the input voltage range is 4.75 V or $V_o + 3\text{ V}$, whichever is higher.

■ Electrical Characteristics

($R_1=4.2\text{ k}\Omega$, $R_2=0.8\text{ k}\Omega$ when $T_a = 25^\circ\text{C}$ and $V_o=5\text{V}$)

Parameter	Symbol	Ratings			Unit
		SI-8005Q			
		min.	typ.	max.	
Reference Voltage	V_{ADJ}	0.485	0.500	0.515	V
	Conditions	$V_{IN}=12\text{V}$, $I_o=1\text{A}$			
Temperature Coefficient of Reference Voltage	$\Delta V_{ADJ}/\Delta T$		0.05		mV/°C
	Conditions	$V_{IN}=12\text{V}$, $I_o=1\text{A}$, $T_a=-40$ to $+85^\circ\text{C}$			
Efficiency	η		90		%
	Conditions	$V_{IN}=12\text{V}$, $I_o=1\text{A}$			
Oscillation Frequency	f_o	450	500	550	kHz
	Conditions	$V_{IN}=16\text{V}$, $I_o=1\text{A}$			
Line Regulation	ΔV_{OLINE}		30	60	mV
	Conditions	$V_{IN}=8$ to 28V , $I_o=1\text{A}$			
Load Regulation	ΔV_{OLOAD}		30	60	mV
	Conditions	$V_{IN}=12\text{V}$, $I_o=0.1$ to 3.5A			
Overcurrent Protection Starting Current	I_s	3.6		6.0	A
	Conditions	$V_{IN}=12\text{V}$			
Quiescent Circuit Current	I_q		18		mA
	Conditions	$V_{IN}=12\text{V}$, $I_o=0\text{A}$, $V_{EN}=\text{open}$			
	$I_{q(\text{OFF})}$			20	μA
SS Pin	Outflow Current at Low Voltage	I_{SSL}	5		μA
		Conditions	$V_{IN}=16\text{V}$, $V_{SSL}=0\text{V}$		
EN Pin	High Level Voltage	V_{CEN}	2.8		V
		Conditions	$V_{IN}=12\text{V}$		
	Low Level Voltage	V_{CEL}			2.2
Inflow Current at Low Voltage	I_{CIEH}		5		μA
	Conditions	$V_{EN}=0\text{V}$			
Error Amplifier Voltage Gain	AEA		1000		V/V
Error Amplifier Transformer Conductance	GEA		800		$\mu\text{A}/\text{V}$
Current Sense Amplifier Impedance	$1/GCS$		0.35		V/A
Maximum ON Duty	DMAX		92		%
Minimum ON Time	DMIN		100		nsec.

*: Pin 8 is the SS pin. Soft start at power on can be performed with a capacitor connected to this pin. The SS pin is pulled up to the power supply in the IC, so applying the external voltage is prohibited.

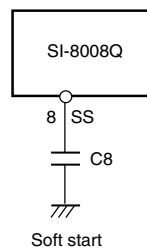

External Dimensions (HSOP8)

(Unit : mm)

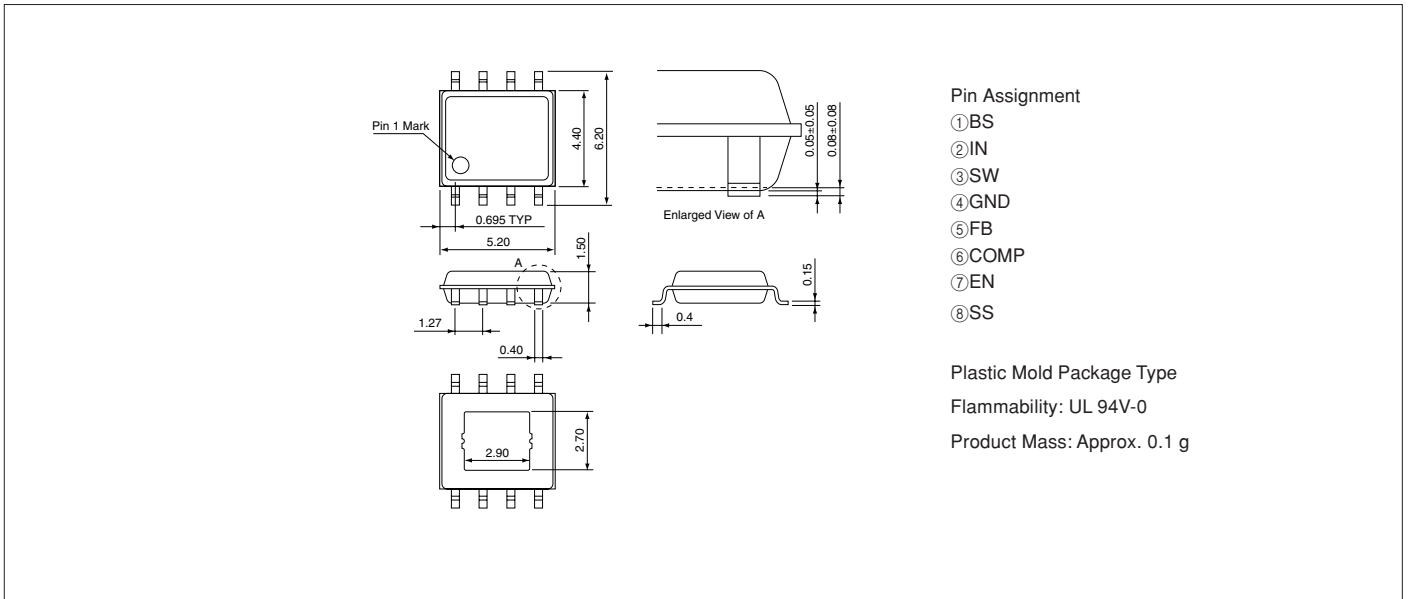

Block Diagram

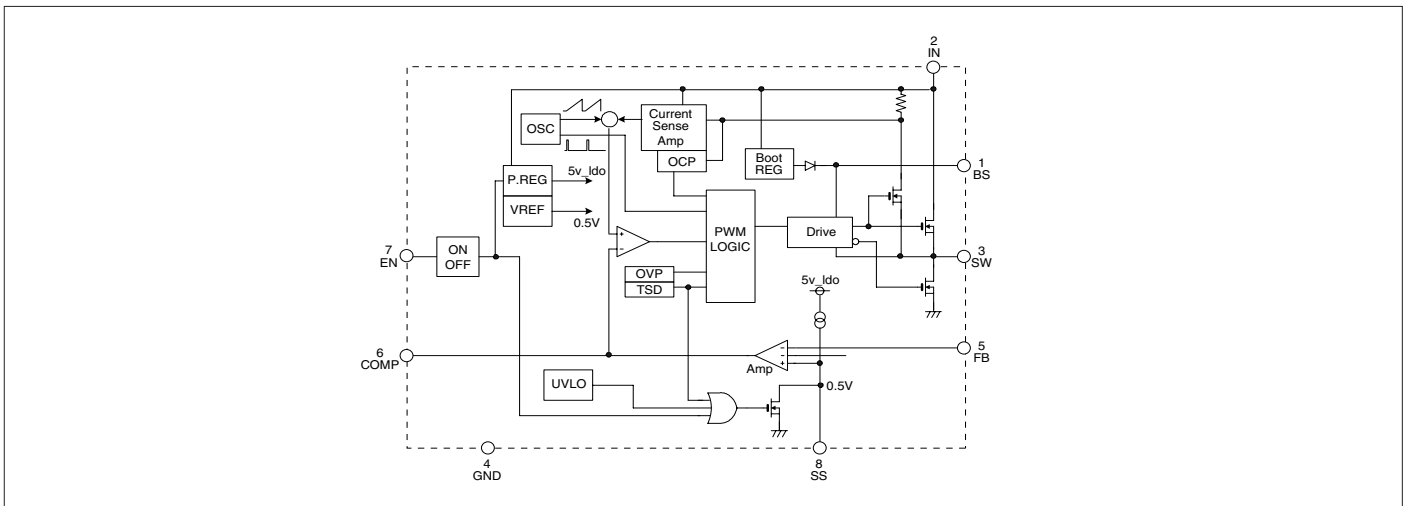

Typical Connection Diagram

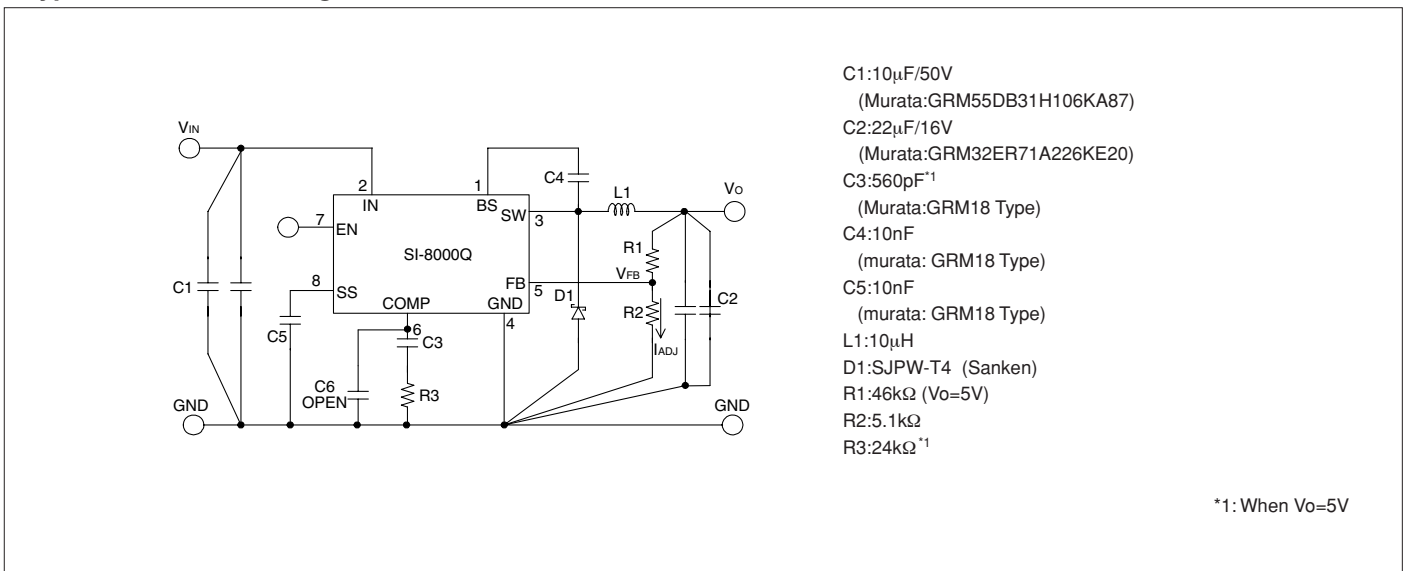

SI-8000FD Series Surface Mount, Separate Excitation Step-down Switching Mode

■Features

- Surface-mount package (TO263-5)
- Output current: 3.5 A
- High efficiency: 83% ($V_o = 5\text{ V}$, $V_{IN} = 15\text{ V}$, $I_o = 2\text{ A}$)
- Requires only 6 discrete components
- Built-in reference oscillator (300 kHz)
- Built-in drooping-type overcurrent and thermal protection circuits
- Built-in soft start circuit (Output ON/OFF available)
 - SI-8001FDE
- Built-in on/off function (active Low)
 - SI-8001FDL
- Low current consumption during off
 - SI-8001FDL

■Lineup

Part Number	SI-8001FDE	SI-8001FDL
V_o (V)	Variable(0.8 to 24)	
I_o (A)	3.5	
Function	Soft start	ON/OFF

■Absolute Maximum Ratings

Parameter	Symbol	Ratings		Unit	Conditions
		SI-8001FDE	SI-8001FDL		
Input Voltage	V_{IN}	43		V	
ON/OFF Control Voltage	V_c	—	V_{IN}	V	
Power Dissipation ^{*1}	P_D	3		W	When mounted on glass-epoxy board measuring 40x40 mm (copper laminate area: 100%)
Junction Temperature ^{*2}	T_j	+150		°C	
Storage Temperature	T_{stg}	-40 to +150		°C	
Thermal Resistance (Junction to Case)	θ_{j-c}	3 ^{*1}		°C/W	When mounted on glass-epoxy board measuring 40x40 mm (copper laminate area: 100%)
Thermal Resistance (Junction to Ambient Air)	θ_{j-a}	33.3 ^{*1}		°C/W	When mounted on glass-epoxy board measuring 40x40 mm (copper laminate area: 100%)

*1 : Limited by thermal protection circuit

*2 : This product has built-in thermal protection circuits that may activate when the junction temperature exceeds 130°C. The recommended design for the junction temperature during IC operation is below 125°C.

■Applications

- DVD recorder, FPD-TV
- OA equipment, such as printers
- Onboard local power supplies

■Recommended Operating Conditions

Parameter	Symbol	Ratings		Unit
		SI-8001FDE	SI-8001FDL	
Input Voltage Range	V_{IN}	$V_o + 3^{*1}$ to 40		V
Output Voltage Range	V_o	0.8 to 24		V
Output Current Range	I_o	0 to 3.5		A
Operating Junction Temperature Range	T_{jop}	-30 to +100		°C
Operating Temperature Range	T_{op}	-30 to +85		°C

*1: The minimum value of the input voltage range is 4.5 V or $V_o + 3\text{ V}$, whichever is higher.

■Electrical Characteristics

($R_1 = 4.2\text{ k}\Omega$, $R_2 = 0.8\text{ k}\Omega$ when $T_a = 25^\circ\text{C}$ and $V_o = 5\text{V}$)

Parameter	Symbol	Ratings						Unit
		SI-8001FDE			SI-8001FDL			
		min.	typ.	max.	min.	typ.	max.	
Reference Voltage	V_{ADJ}	0.784	0.800	0.816	0.784	0.800	0.816	V
Temperature Coefficient of Reference Voltage	$\Delta V_{ADJ}/\Delta T$	± 0.1			± 0.1			mV/°C
	Conditions	$V_{IN} = 15\text{V}$, $I_o = 0.2\text{A}$, $T_c = 0$ to 100°C			$V_{IN} = 15\text{V}$, $I_o = 0.2\text{A}$, $T_c = 0$ to 100°C			
Efficiency	η	83			83			%
	Conditions	$V_{IN} = 15\text{V}$, $I_o = 2\text{A}$			$V_{IN} = 15\text{V}$, $I_o = 2\text{A}$			
Oscillation Frequency	f_o	270	300	330	270	300	330	kHz
	Conditions	$V_{IN} = 15\text{V}$, $I_o = 2\text{A}$			$V_{IN} = 15\text{V}$, $I_o = 2\text{A}$			
Line Regulation	ΔV_{OLINE}	80			80			mV
	Conditions	$V_{IN} = 10$ to 30V , $I_o = 2\text{A}$			$V_{IN} = 10$ to 30V , $I_o = 2\text{A}$			
Load Regulation	ΔV_{LOAD}	50			50			mV
	Conditions	$V_{IN} = 15\text{V}$, $I_o = 0.2$ to 3.5A			$V_{IN} = 15\text{V}$, $I_o = 0.2$ to 3.5A			
Overcurrent Protection Starting Current	I_s	3.6			3.6			A
	Conditions	$V_{IN} = 15\text{V}$			$V_{IN} = 15\text{V}$			
SS Pin ^{*1}	Low Level Voltage	V_{SSL}		0.5	—	—	—	V
	Outflow Current at Low Voltage	I_{SSL}	6	30	—	—	—	
ON/OFF Pin ^{*2}	ON/OFF Control Voltage (Output on)	V_c , IH	—	—	—	—	0.8	V
	ON/OFF Control Voltage (Output off)	V_c , IL	—	—	2.0	—	—	
	ON/OFF Control Current (Output on)	I_c , IH	—	—	—	—	100	
Quiescent Circuit Current	I_q		6			6		mA
		Conditions	$V_{IN} = 15\text{V}$, $I_o = 0\text{A}$			$V_{IN} = 15\text{V}$, $I_o = 0\text{A}$		
	I_q (OFF)		200	600		30	200	μA
		Conditions	$V_{IN} = 15\text{V}$, $V_{SS} = 0\text{V}$			$V_{IN} = 15\text{V}$, $V_c = 2\text{V}$		

*1: Pin 5 is the SS pin. Soft start at power on can be performed with a capacitor connected to this pin. The output can also be turned ON/OFF with this pin. The output is stopped by setting the voltage of this pin to V_{SSL} or lower. SS-pin voltage can be changed with an open-collector drive circuit of a transistor. When using both the soft-start and ON/OFF functions together, the discharge current from C3 flows into the ON/OFF control transistor. Therefore, limit the current securely to protect the transistor if C3 capacitance is large. The SS pin is pulled up (3.7 V typ.) to the power supply in the IC, so applying the external voltage is prohibited. If this pin is not used, leave it open.

*2: Output is OFF when the output control terminal VC is open. Each input level is equivalent to LS-TTL. Therefore, the device can be driven directly by LS-TTLs.

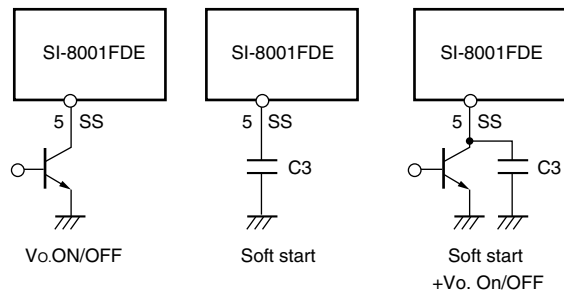

External Dimensions (TO263-5)

(Unit : mm)

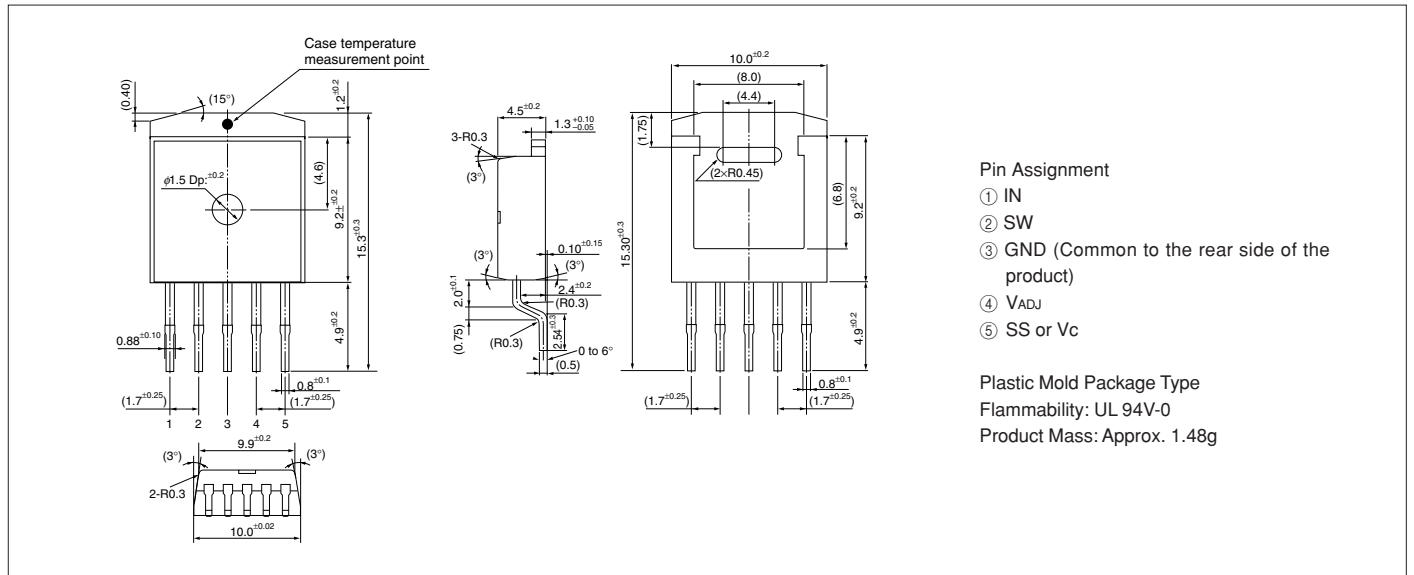

Block Diagram



Typical Connection Diagram



SI-8000HD Series Surface-Mount, Separate Excitation Step-down Switching Mode

■Features

- Surface-mount package (TO263-5)
- Output current: 5.5 A
- High efficiency: 83% (at TYP, $V_o = 5\text{ V}$)
- Requires only 5 discrete components (SI-8008HD)
- Built-in reference oscillator (150 kHz)
- Built-in drooping-type overcurrent and thermal protection circuits
- Built-in soft start circuit (Output ON/OFF available)
- Low current consumption during off

■Applications

- DVD recorder, FPD-TV
- Onboard local power supplies
- OA equipment

■Absolute Maximum Ratings

Parameter	Symbol	Ratings	Unit	Conditions
Input Voltage	V_{IN}	43	V	
Power Dissipation ^{*1}	P_D	3	W	When mounted on glass-epoxy board measuring 40×40 mm (copper laminate area: 100%)
Junction Temperature ^{*2}	T_J	+150	°C	
Storage Temperature	T_{stg}	-40 to +150	°C	
Thermal Resistance (Junction to Case)	θ_{j-c}	3	°C/W	When mounted on glass-epoxy board measuring 40×40 mm (copper laminate area: 100%)
Thermal Resistance (Junction to Ambient Air)	θ_{j-a}	33.3	°C/W	When mounted on glass-epoxy board measuring 40×40 mm (copper laminate area: 100%)

*1: Limited by thermal protection circuit

*2: This product has built-in thermal protection circuits that may activate when the junction temperature exceeds 130°C. The recommended design for the junction temperature during IC operation is below 125°C.

■Recommended Operating Conditions

Parameter	Symbol	Ratings	Unit	Conditions
		SI-8008HD		
Input Voltage Range	V_{IN}	V_o+3 ^{*1} to 40	V	
Output Voltage Range	V_o	0.8 to 24	V	
Output Current Range	I_o	0 to 5.5	A	$V_{IN} \geq V_o+3V$
Operating Junction Temperature Range	T_{jop}	-30 to +100	°C	
Operating Temperature Range	T_{op}	-30 to +85	°C	

*1: The minimum value of the input voltage range is 4.5 V or $V_o+3\text{ V}$, whichever is higher.

■Electrical Characteristics

($R1=4.2k\Omega$, $R2=0.8k\Omega$ when $T_a=25^\circ\text{C}$ and $V_o=5\text{V}$)

Parameter	Symbol	Ratings			Unit
		SI-8008HD			
		min.	typ.	max.	
Reference Voltage	V_{ADJ}	0.784	0.800	0.816	V
Temperature Coefficient of Reference Voltage	$(\Delta V_{ADJ}/\Delta T)$		+0.1		mV/°C
	Conditions	$V_{IN}=15\text{V}$, $I_o=1\text{A}$, $T_c=0$ to 100°C			
Efficiency	η		83		%
	Conditions	$V_{IN}=15\text{V}$, $I_o=3\text{A}$			
Oscillation Frequency	f_o		150		kHz
	Conditions	$V_{IN}=15\text{V}$, $I_o=3\text{A}$			
Line Regulation	ΔV_{OLINE}		60	80	mV
	Conditions	$V_{IN}=10$ to 30V , $I_o=3\text{A}$			
Load Regulation	ΔV_{OLOAD}		20	50	mV
	Conditions	$V_{IN}=15\text{V}$, $I_o=0.2$ to 5.5A			
Overcurrent Protection Starting Current	I_s	5.6	6.5	7.5	A
	Conditions	$V_{IN}=15\text{V}$			
SS Pin ^{*1}	Low Level Voltage	V_{SSL}		0.5	V
	Outflow Current at Low Voltage	I_{SSL}		10	30
Quiescent Circuit Current		I_q		6	
	Conditions		$V_{IN}=15\text{V}$, $I_o=0\text{A}$		
	$I_{q(OFF)}$		200	400	μA
		Conditions	$V_{IN}=15\text{V}$, $V_{SS}=0\text{V}$		

*1: Pin 5 is the SS pin. Soft start at power on can be performed with a capacitor connected to this pin. The output can also be turned ON/OFF with this pin.

The output is stopped by setting the voltage of this pin to V_{SSL} or lower. SS-pin voltage can be changed with an open-collector drive circuit of a transistor. When using both the soft-start and ON/OFF functions together, the discharge current from C3 flows into the ON/OFF control transistor. Therefore, limit the current securely to protect the transistor if C3 capacitance is large. The SS pin is pulled up (3.7 V typ.) to the power supply in the IC, so applying the external voltage is prohibited. If this pin is not used, leave it open.

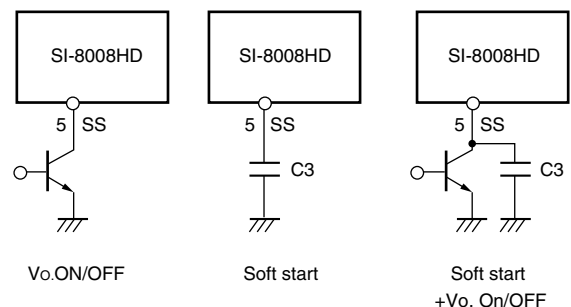

External Dimensions (TO263-5)

(Unit : mm)



Block Diagram



Typical Connection Diagram



Reference Data



SI-8000E Series Full-Mold, Separate Excitation Step-down Switching Mode

■ Features

- Compact full-mold package (equivalent to TO220)
- High efficiency: 80%
- Requires only 4 discrete components
- Internally-adjusted phase compensation and output voltage
- Built-in reference oscillator (60kHz)
- Built-in overcurrent and thermal protection circuits

■ Applications

- Power supplies for telecommunication equipment
- Onboard local power supplies

■ Lineup

Part Number	SI-8050E
Vo(V)	5.0
Io(A)	0.6

■ Absolute Maximum Ratings

Parameter	Symbol	Ratings	Unit
DC Input Voltage	V _{IN}	43	V
Power Dissipation	P _{D1}	14(With infinite heatsink)	W
	P _{D2}	1.5(Without heatsink, stand-alone operation)	W
Junction Temperature	T _J	+125	°C
Storage Temperature	T _{Stg}	-40 to +125	°C
Thermal Resistance(junction to case)	θ _{J-c}	7.0	°C/W
Thermal Resistance(junction to ambient air)	θ _{J-a}	66.7	°C/W

■ Recommended Operating Conditions

Parameter	Symbol	Ratings		Unit
		SI-8050E		
DC Input Voltage Range	V _{IN}	7 to 40		V
Output Current Range	I _O	0 to 0.6		A
Operating Junction Temperature Range	T _{JOP}	-30 to +125		°C
Operating Temperature Range	T _{OP}	-30 to +125		°C

■ Electrical Characteristics

(T_a=25°C)

Parameter	Symbol	Ratings			Unit
		SI-8050E			
		min.	typ.	max.	
Output Voltage	V _O	4.80	5.00	5.20	V
	Conditions	V _{IN} =20V, I _O =0.3A			
Efficiency	η		80		%
	Conditions	V _{IN} =20V, I _O =0.3A			
Oscillation Frequency	f		60		kHz
	Conditions	V _{IN} =20V, I _O =0.3A			
Line Regulation	ΔV _{O(LINE)}		80	100	mV
	Conditions	V _{IN} =10 to 30V, I _O =0.3A			
Load Regulation	ΔV _{O(LOAD)}		30	40	mV
	Conditions	V _{IN} =20V, I _O =0.1 to 0.4A			
Temperature Coefficient of Output Voltage	ΔV _O /ΔT _a		±0.5		mV/°C
Overcurrent Protection Starting Current	I _{SI}	0.61			A
	Conditions	V _{IN} =10V			

External Dimensions (TO220F-5)

(Unit : mm)



Block Diagram

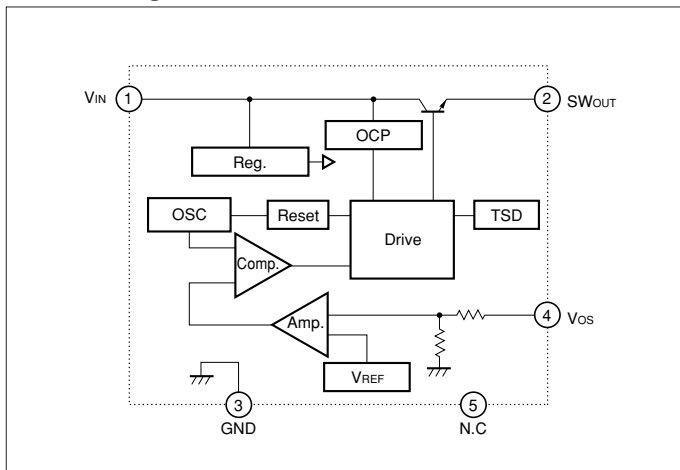

Typical Connection Diagram

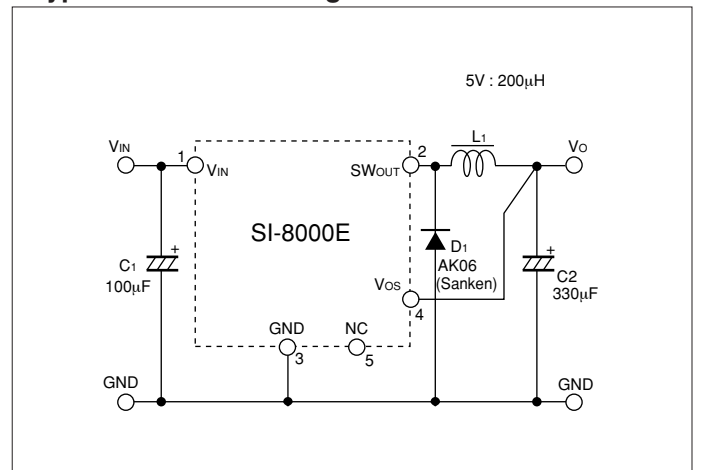

Ta-Pd Characteristics

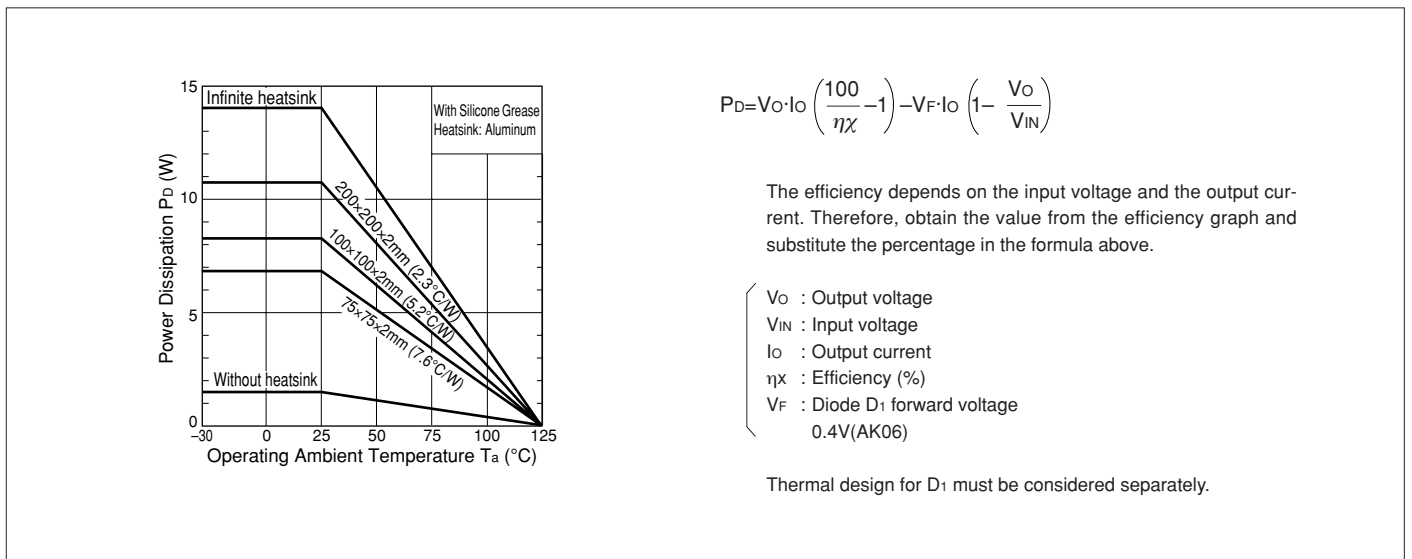

SI-8000JF Series Full-Mold, Separate Excitation Step-down Switching Mode

Features

- Compact full-mold package (equivalent to TO220)
- Output current: 1.5A
- High efficiency: 67 to 88%
- Requires only 4 discrete components
- Internally-adjusted phase compensation and output voltage
- Capable of downsize a choke-coil due to IC's high switching frequency (125kHz). (Compared with conventional Sanken devices)
- Built-in foldback-overcurrent and thermal protection circuits
- Output ON/OFF available (circuit current at output OFF: 200 μ A max.)
- Soft start available by ON/OFF pin

Lineup

Part Number	SI-8015JF	SI-8033JF	SI-8050JF	SI-8120JF
V _O (V)*	1.59	3.3	5.0	12.0
I _O (A)	1.5			

* V_{REF}(V) for SI-8015JF

Absolute Maximum Ratings

Parameter	Symbol	Ratings	Unit
DC Input Voltage	V _{IN}	43	V
Power Dissipation	P _{D1}	16.6 (with infinite heatsink)	W
	P _{D2}	1.5 (without heatsink, standalone operation)	W
Junction Temperature	T _j	+125	°C
Storage Temperature	T _{stg}	-40 to +125	°C
Thermal Resistance (Junction to Case)	θ_{j-c}	6.0	°C/W

Applications

- Power supplies for telecommunication equipment
- Onboard local power supplies

Recommended Operating Conditions

Parameter	Symbol	Ratings				Unit	Conditions
		SI-8015JF*	SI-8033JF	SI-8050JF	SI-8120JF		
DC Input Voltage Range	V _{IN1}	V _O +2 to 40	5.3 to 40	7 to 40	14 to 40	V	I _O =0 to 1A
	V _{IN2}	V _O +3 to 40	6.3 to 40	8 to 40	15 to 40	V	I _O =0 to 1.5A
Output Current Range	I _O	0 to 1.5				A	V _{IN} ≥V _O +3V
Operating Junction Temperature Range	T _{top}	-30 to +125				°C	

* SI-8015JF is a variable output voltage type. The variable output voltage range is from 2.5 V to 24 V.

Electrical Characteristics

(T_a=25°C)

Parameter	Symbol	Ratings												Unit
		SI-8015JF			SI-8033JF			SI-8050JF			SI-8120JF			
		min.	typ.	max.	min.	typ.	max.	min.	typ.	max.	min.	typ.	max.	
Output Voltage ¹	V _O ²	1.558	1.59	1.622	3.234	3.30	3.366	4.90	5.00	5.10	11.76	12.00	12.24	V
	Conditions	V _{IN} =12V, I _O =0.5A			V _{IN} =15V, I _O =0.5A			V _{IN} =20V, I _O =0.5A			V _{IN} =24V, I _O =0.5A			
Efficiency	η	67			77			82			88			%
	Conditions	V _{IN} =12V, I _O =0.5A			V _{IN} =15V, I _O =0.5A			V _{IN} =20V, I _O =0.5A			V _{IN} =24V, I _O =0.5A			
Oscillation Frequency	f	125			125			125			125			kHz
	Conditions	V _{IN} =12V, I _O =0.5A			V _{IN} =15V, I _O =0.5A			V _{IN} =20V, I _O =0.5A			V _{IN} =24V, I _O =0.5A			
Line Regulation	ΔV_{OLINE}	25 80			25 80			40 100			60 130			mV
	Conditions	V _{IN} =8 to 30V, I _O =0.5A			V _{IN} =8 to 30V, I _O =1.0A			V _{IN} =10 to 30V, I _O =1.0A			V _{IN} =18 to 30V, I _O =1.0A			
Load Regulation	ΔV_{OLOAD}	10 30			10 30			10 40			10 40			mV
	Conditions	V _{IN} =12V, I _O =0.2 to 0.8A			V _{IN} =15V, I _O =0.5 to 1.5A			V _{IN} =20V, I _O =0.5 to 1.5A			V _{IN} =24V, I _O =0.5 to 1.5A			
Temperature Coefficient of Output Voltage ³	$\Delta V_O/\Delta T_a$ ⁴	±0.5			±0.5			±0.5			±1.0			mV/°C
Overcurrent Protection Starting Current	I _{SI}	1.6			1.6			1.6			1.6			A
ON/OFF ⁵ Terminal	Low Level Voltage	V _{SSL}			0.5			0.5			0.5			V
	Outflow Current at Low Voltage	I _{SSL}			100			100			100			μ A
Quiescent Circuit Current	I _q	7			7			7			7			mA
	Conditions	V _{IN} =12V, I _O =0A			V _{IN} =15V, I _O =0A			V _{IN} =20V, I _O =0A			V _{IN} =24V, I _O =0A			
	I _{q(OFF)}	200			200			200			200			μ A
Conditions	V _{IN} =12V, V _{ON/OFF} =0.3V			V _{IN} =15V, V _{ON/OFF} =0.3V			V _{IN} =20V, V _{ON/OFF} =0.3V			V _{IN} =24V, V _{ON/OFF} =0.3V				

*1: Reference voltage for SI-8015JF

*3: Temperature Coefficient of Reference Voltage for SI-8015JF

*2: V_{REF} for SI-8015JF

*4: $\Delta V_{REF}/\Delta T_a$ for SI-8015JF

*5: Pin 5 is the ON/OFF pin. Soft start at power on can be performed with a capacitor connected to this pin.

The output can also be turned ON/OFF with this pin. The output is stopped by setting the voltage of this pin to V_{SSL} or lower. ON/OFF-pin voltage can be changed with an open-collector drive circuit of a transistor. When using both the soft-start and ON/OFF functions together, the discharge current from C₃ flows into the ON/OFF control transistor. Therefore, limit the current securely to protect the transistor if C₃ capacitance is large. The ON/OFF pin is pulled up to the power supply in the IC, so applying the external voltage is prohibited. If this pin is not used, leave it open.

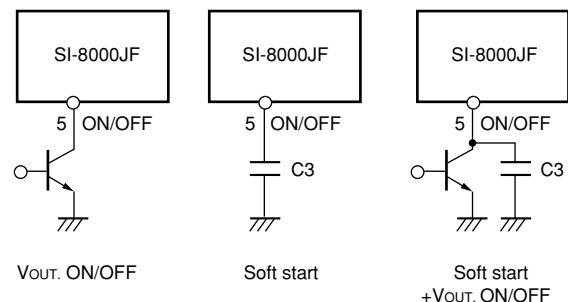

External Dimensions (TO220F-5)

(Unit : mm)

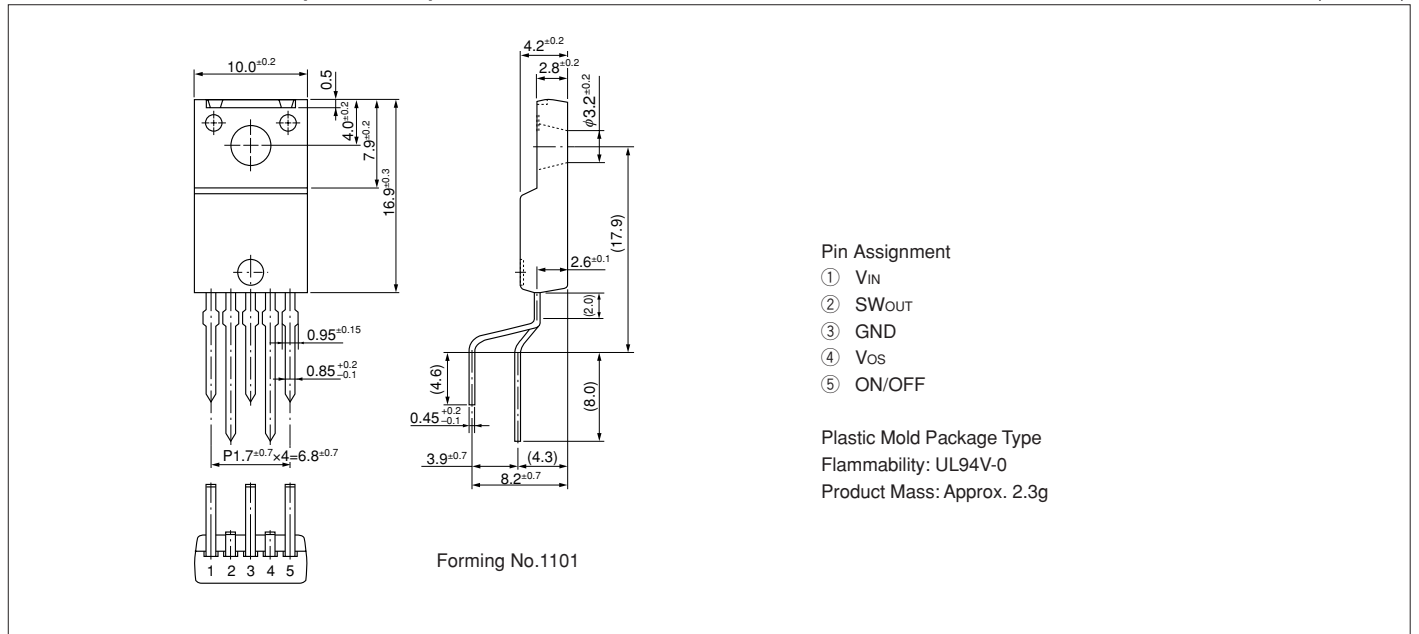

Block Diagram



Typical Connection Diagram



SI-8000TFE Series Full-Mold, Separate Excitation Step-down Switching Mode

Features

- Compact full-mold package (equivalent to TO220)
- Output current: 1.5 A
- High efficiency: 81% typ. (at $V_o = 5\text{ V}$)
- Requires only 4 discrete components
- Built-in reference oscillator (300 kHz)
- Built-in dropping-type-overcurrent and thermal protection circuits
- Output ON/OFF available (circuit current at output OFF: $200\mu\text{A}$ typ.)
- Soft start available by ON/OFF pin

Applications

- Onboard local power supplies
- AV equipment
- OA equipment

Lineup

Part Number	SI-8008TFE	SI-8050TFE
V_o (V)	Variable (0.8 to 24)	5
I_o (A)		1.5

Absolute Maximum Ratings

Parameter	Symbol	Ratings	Unit	Conditions
DC Input Voltage	V_{IN}	43	V	
Power Dissipation	P_{D1-1}	17.8 (with infinite heatsink)	W	Limited by thermal protection, $T_{jmax}=150^\circ\text{C}$
	P_{D1-2}	14.2 (with infinite heatsink)		$T_{jmax}=125^\circ\text{C}$
	P_{D2-1}	2.15 (without heat sink, standalone operation)		Limited by thermal protection, $T_{jmax}=150^\circ\text{C}$
	P_{D2-2}	1.72 (without heatsink, standalone operation)		$T_{jmax}=125^\circ\text{C}$
Junction Temperature*	T_j	-30 to +150	$^\circ\text{C}$	
Storage Temperature	T_{stg}	-40 to +150	$^\circ\text{C}$	
Thermal Resistance (Junction to Case)	θ_{j-c}	7	$^\circ\text{C}/\text{W}$	
Thermal Resistance (Junction to Ambient Air)	θ_{j-a}	58	$^\circ\text{C}/\text{W}$	

*: This product has built-in thermal protection circuits that may operate when the junction temperature rises above 130°C . The recommended design for the junction temperature during operation is below 125°C .

Recommended Operating Conditions

Parameter	Symbol	Ratings		Unit
		SI-8008TFE	SI-8050TFE	
Input Voltage Range	V_{IN}	V_o+3^1 to 40	8 to 40	V
Output Voltage Range	V_o	0.8 to 24	5.0	V
Output Current Range	I_o		0 to 1.5	A
Operating Junction Temperature Range	T_{jop}		-20 to +125	$^\circ\text{C}$
Operating Temperature Range	T_{op}		-20 to +85	$^\circ\text{C}$

*1: The minimum value of an input voltage range is the higher of 4.5 V or $V_o + 3\text{ V}$.

Electrical Characteristics

($T_a=25^\circ\text{C}$)

Parameter	Symbol	Ratings			Ratings			Unit
		SI-8008TFE			SI-8050TFE			
		min.	typ.	max.	min.	typ.	max.	
Output Voltage	V_o				4.90	5.00	5.10	V
Reference Voltage	V_{ADJ}	0.784	0.800	0.816				
	Conditions	$V_{IN}=15\text{V}, I_o=0.1\text{A}$			$V_{IN}=15\text{V}, I_o=0.1\text{A}$			
Temperature Coefficient of Output Voltage	$\Delta V_o/\Delta T$					± 0.5		$\text{mV}/^\circ\text{C}$
Temperature Coefficient of Reference Voltage	$\Delta V_{REF}/\Delta T$		± 0.1					
	Conditions	$V_{IN}=15\text{V}, I_o=0.1\text{A}, T_c=0$ to 100°C			$V_{IN}=15\text{V}, I_o=0.1\text{A}, T_c=0$ to 100°C			
Efficiency	η		81			81		%
	Conditions	$V_{IN}=15\text{V}, I_o=0.5\text{A}$			$V_{IN}=15\text{V}, I_o=0.5\text{A}$			
Oscillation Frequency	f_o		300			300		kHz
	Conditions	$V_{IN}=15\text{V}, I_o=0.5\text{A}$			$V_{IN}=15\text{V}, I_o=0.5\text{A}$			
Line Regulation	ΔV_{OLINE}		60	80		60	80	mV
	Conditions	$V_{IN}=10$ to $30\text{V}, I_o=0.5\text{A}$			$V_{IN}=10$ to $30\text{V}, I_o=0.5\text{A}$			
Load Regulation	ΔV_{OLOAD}		10	40		10	40	mV
	Conditions	$V_{IN}=15\text{V}, I_o=0.2$ to 1.5A			$V_{IN}=15\text{V}, I_o=0.2$ to 1.5A			
Overcurrent Protection Starting Current	I_s	1.6			1.6			A
	Conditions	$V_{IN}=15\text{V}$			$V_{IN}=15\text{V}$			
ON/OFF Pin*	Low Level Voltage	V_{SSL}		0.5			0.5	V
	Outflow Current at Low Voltage	I_{SSL}		10	40		10	
	Conditions	$V_{SSL}=0\text{V}$			$V_{SSL}=0\text{V}$			
Quiescent Circuit Current	I_q		6			6		mA
	Conditions	$V_{IN}=15\text{V}, I_o=0\text{A}$			$V_{IN}=15\text{V}, I_o=0\text{A}$			
	$I_{q(OFF)}$		200	400		200	400	μA
Conditions	$V_{IN}=15\text{V}, V_{SS}=0\text{V}$			$V_{IN}=15\text{V}, V_{SS}=0\text{V}$				

*: Pin 5 is the SS pin. Soft start at power on can be performed with a capacitor connected to this pin. The output can also be turned ON/OFF with this pin. The output is stopped by setting the voltage of this pin to V_{SSL} or lower. SS-pin voltage can be changed with an open-collector drive circuit of a transistor. When using both the soft-start and ON/OFF functions together, the discharge current from C3 flows into the ON/OFF control transistor. Therefore, limit the current securely to protect the transistor if C3 capacitance is large. The SS pin is pulled up to the power supply in the IC, so applying the external voltage is prohibited. If the pin is not used, leave it open.

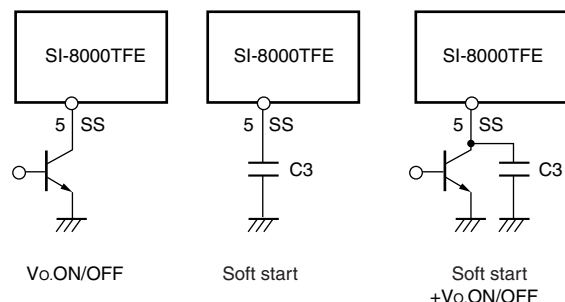

External Dimensions (TO220F-5)

(Unit : mm)

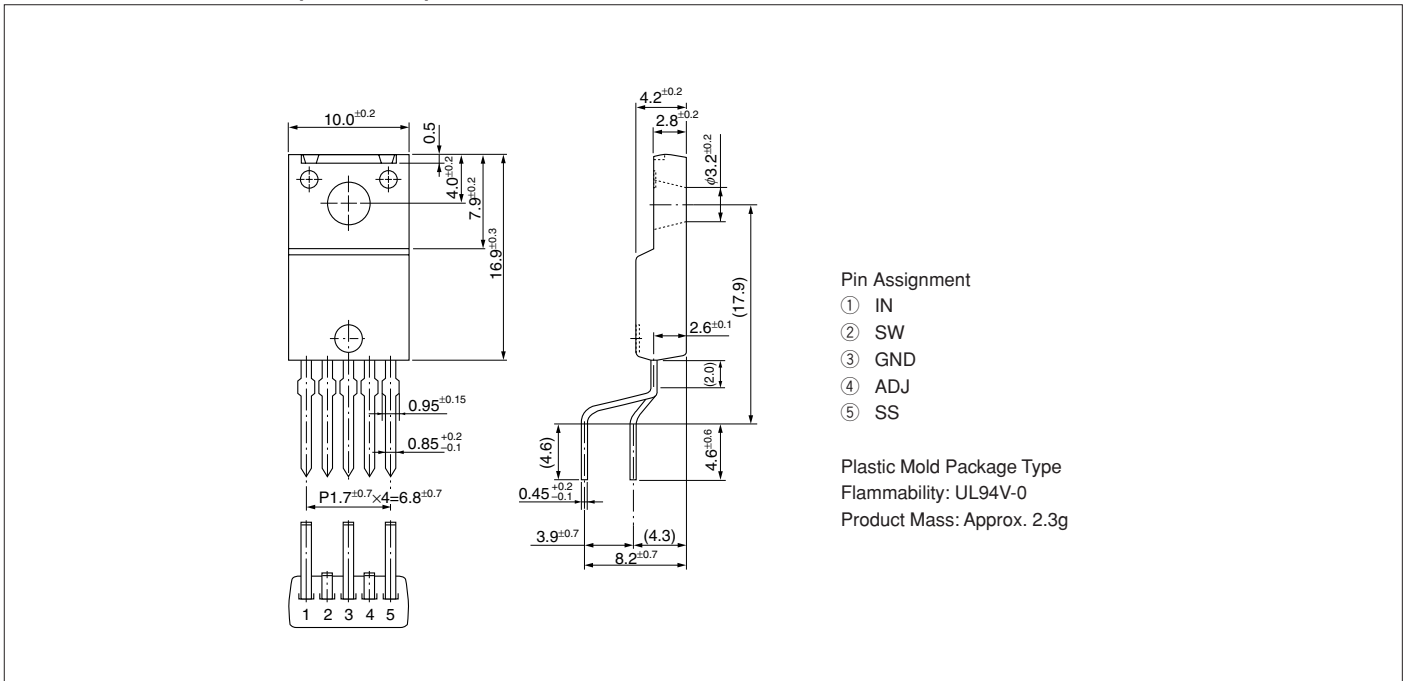

Block Diagram

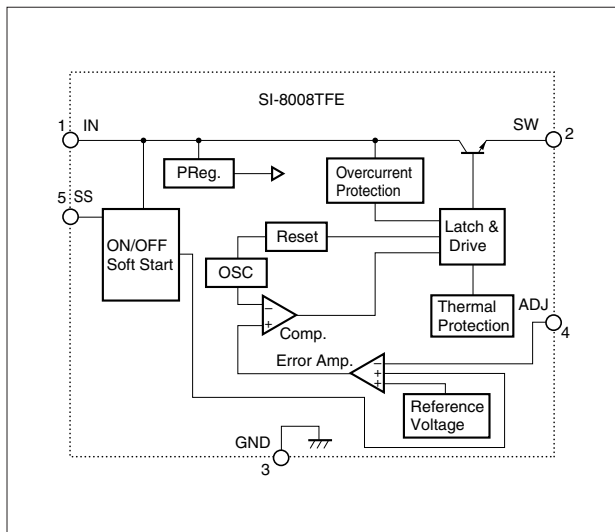

Typical Connection Diagram

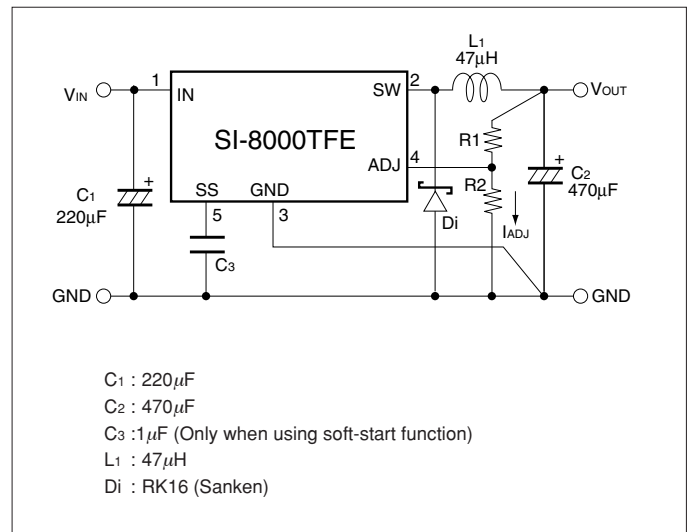

SI-8000GL Series Compact, Separate Excitation Step-down Switching Mode

Features

- DIP 8 pin package
- Output current: 1.5A
- High efficiency: 86% (at $V_{IN} = 20V$, $I_O = 1A$, $V_O = 5V$)
- Capable of downsize a choke-coil due to IC's high switching frequency (250kHz). (Compared with conventional Sanken devices)
- The output-voltage-variable type can vary its output voltage from 1V to 14V because of its low reference voltage (V_{REF}) of 1V.
- Wide Input Voltage Range (8 to 50V)
- Output ON/OFF available
- Built-in overcurrent protection and thermal protection circuits

Absolute Maximum Ratings

Parameter	Symbol	Ratings	Unit
DC Input Voltage	V_{IN}	53	V
Power Dissipation	P_D^{*1}	1	W
Junction Temperature	T_j	+125	°C
Storage Temperature	T_{stg}	-40 to +125	°C
Thermal Resistance (junction to case)	θ_{j-c}	28	°C/W
Thermal Resistance (junction to ambient air)	θ_{j-a}	100	°C/W

*1: Limited by thermal protection.

Applications

- Onboard local power supplies
- OA equipment
- For stabilization of the secondary-side output voltage of switching power supplies

Recommended Operating Conditions

Parameter	Symbol	Ratings		Unit
		SI-8010GL		
DC Input Voltage Range	V_{IN}	(8 or V_O+3) ^{*1} to 50		V
Output Voltage Range	V_O	1 to 14		V
Output Current Range ^{*2}	I_O	0.02 to 1.5 ^{*2}		A
Operating Junction Temperature Range	T_{jop}	-30 to +125		°C
Operating Temperature Range	T_{op}	-30 to +125		°C

*1: The minimum value of an input voltage range is the higher of either 8V or V_O+3V .

*2: Please be sure to let the output current run more than 20 mA. When using by less than 20 mA, there is a possibility that the output voltage becomes unstable.

Electrical Characteristics

($T_a=25^\circ\text{C}$)

Parameter	Symbol	Ratings			Unit
		SI-8010GL (Variable type)			
		min.	typ.	max.	
Reference Voltage	V_{REF}	0.97	1.00	1.03	V
	Conditions	$V_{IN}=12V, I_O=1A$			
Efficiency	Eff		86		%
	Conditions	$V_{IN}=20V, I_O=1A, V_O=5V$			
Oscillation Frequency	F_{OSC}		250		kHz
	Conditions	$V_{IN}=12V, I_O=1A$			
Line Regulation	ΔV_{OLINE}		20	40	mV
	Conditions	$V_{IN}=10$ to $30V, I_O=1A$			
Load Regulation	ΔV_{OLOAD}		10	30	mV
	Conditions	$V_{IN}=12V, I_O=0.1$ to $1.5A$			
Temperature Coefficient of Reference Voltage	$\Delta V_{REF}/\Delta T_a$		± 0.5		mV/°C
Overcurrent Protection Starting Current	I_S	1.6			A
	Conditions	$V_{IN}=12V$			
Quiescent Circuit Current	I_q		7		mA
	Conditions	$V_{IN}=12V, I_O=0A$			
Circuit Current at Output OFF	$I_{q(OFF)}$			400	μA
	Conditions	$V_{IN}=12V, V_{ON/OFF}=0.3V$			
CE/SS* Terminal	Low Level Voltage	V_{SSL}		0.5	V
	Terminal Outflow Current at Low Voltage	I_{SSL}		50	μA
		Conditions	$V_{SSL}=0V$		

*: Pin 2 is the CE/SS pin. Soft start at power on can be performed with a capacitor connected to this pin. The output can also be turned ON/OFF with this pin. The output is stopped by setting the voltage of this pin to V_{SSL} or lower. CE/SS-pin voltage can be changed with an open-collector drive circuit of a transistor.

When using both the soft-start and ON/OFF functions together, the discharge current from C_4 flows into the ON/OFF control transistor. Therefore, limit the current securely to protect the transistor if C_3 capacitance is large. The CE/SS pin is pulled up to the power supply in the IC, so applying the external voltage is prohibited.

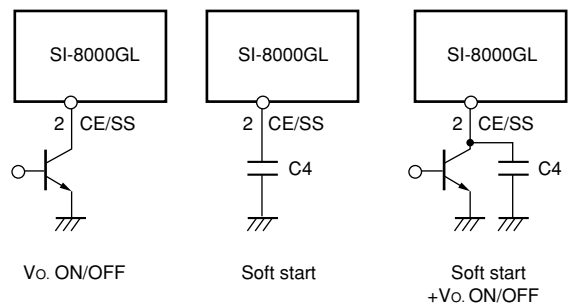

External Dimensions (DIP8)

(Unit: mm)

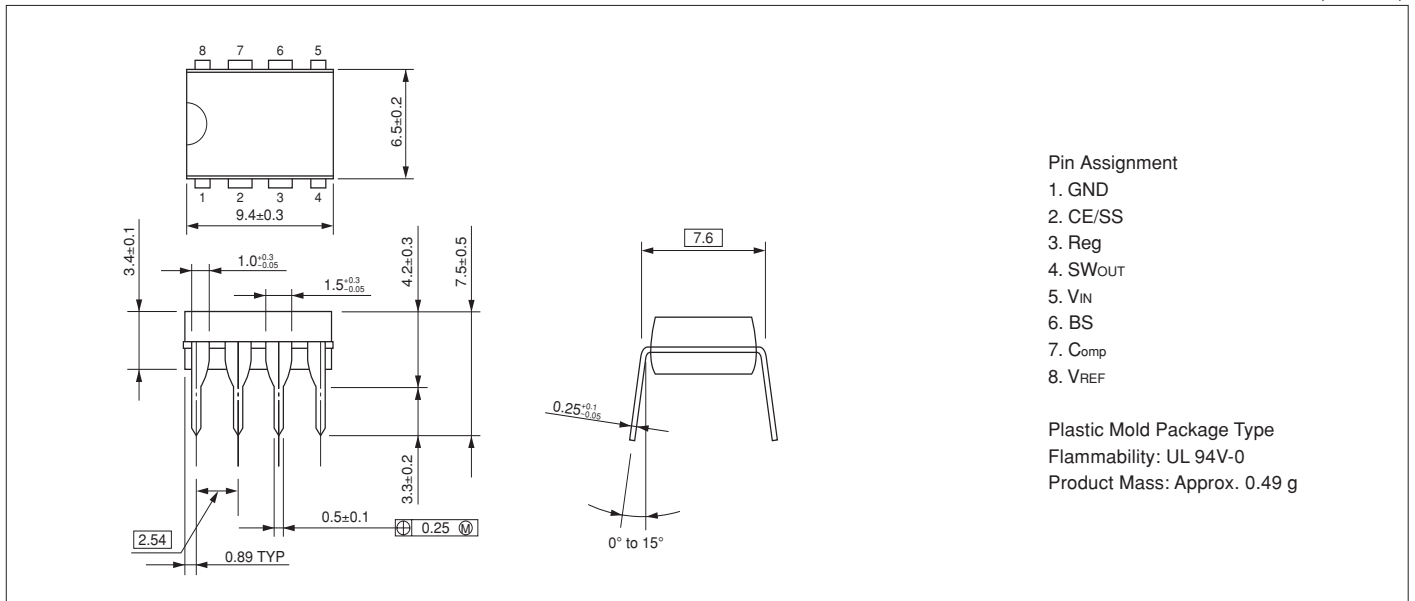

Block Diagram

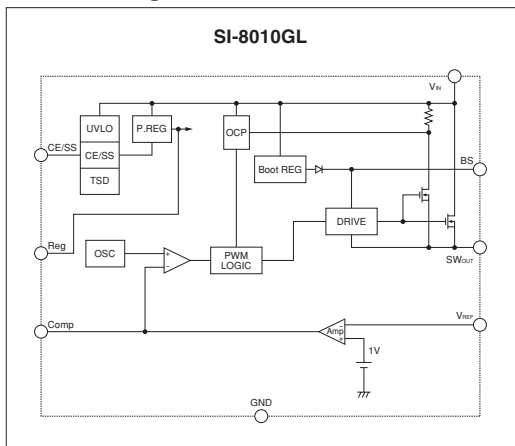

Ta-Pd Characteristics

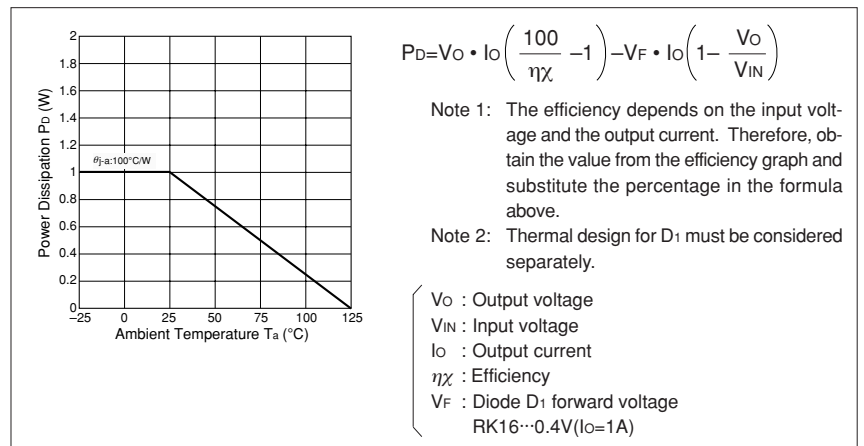

Typical Connection Diagram

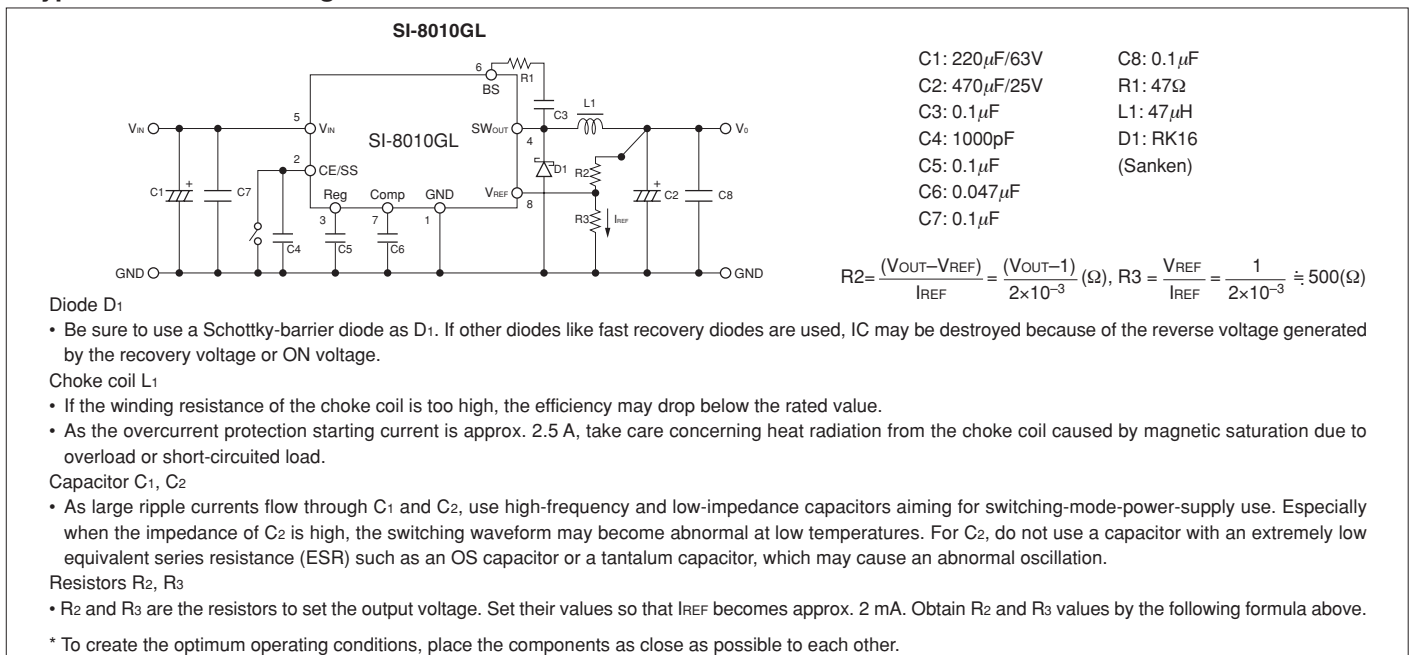

NR887D Current Mode Control, Synchronous Rectifier Step-down Switching Mode

■ Features

- DIP 8 pin package
- Input voltage range (V_{IN}): $V_O + 3$ to 18 V
- Synchronous rectifier mode
- High efficiency: 90%
- Current mode control
- Stable with low-ESR ceramic output capacitors
- Built-in phase compensation component
- Output current: 2 A
- Reference voltage and accuracy of $0.8\text{ V} \pm 2\%$
- Oscillation frequency: 500 kHz
- Output ON/OFF available
- Undervoltage lockout
- Soft start function

■ Applications

- Power supply for LCDTV and PDP
- Power supply for DVD, BD, and STB
- On-board local power supply
- Power supply for switches

■ Electrical Characteristics

($T_a=25^\circ\text{C}$, $V_{IN}=12\text{V}$, $V_O=3.3\text{V}$, and $I_O=1.0\text{A}$, unless otherwise specified)

Parameter	Symbol	Ratings			Unit	Conditions
		min.	typ.	max.		
Reference Voltage	V_{REF}	0.784	0.800	0.816	V	
Temperature Coefficient of Reference Voltage	$\Delta V_{REF}/\Delta T$		± 0.05		mV/C	$T_a=-40^\circ\text{C}$ to $+85^\circ\text{C}$
Efficiency	η		90		%	
Oscillation Frequency	f_o	400	500	600	kHz	
Line Regulation	V_{LINE}		50		mV	$V_{IN}=6.3\text{V}$ to 18V
Load Regulation	V_{Load}		50		mV	$I_O=0.1$ to 2.0A
Overcurrent Protection Starting Current	I_S	3.1		6.0	A	
Quiescent Circuit Current 1	I_{IN}		6		mA	$V_{EN}=10\Omega$ pull up to V_{IN}
Quiescent Circuit Current 2	$I_{IN(off)}$			10	μA	$I_O=0\text{A}$, $V_{EN}=0\text{V}$
SS Pin	Outflow Current at Low Voltage	6	10	14	μA	$V_{SS}=0\text{V}$
	Open Voltage		3.0		V	
EN Pin	Inflow Current		50	100	μA	$V_{EN}=10\text{V}$
	On Threshold Voltage	0.7	1.4	2.1	V	
Maximum ON Duty	$DMAX$		90		%	
Minimum ON Time	$DMIN$		150		nsec	
Thermal Protection Start Temperature	TSD	151	165		$^\circ\text{C}$	
Thermal Protection Return Hysteresis	TSD_hys		20		$^\circ\text{C}$	

*: Pin 8 is the SS pin. Soft start at power on can be performed with a capacitor connected to this pin. The SS pin is pulled up to the power supply in the IC, so applying the external voltage is prohibited.

■ Absolute Maximum Ratings

Parameter	Symbol	Ratings	Unit	Conditions
Input Voltage	V_{IN}	20	V	
Power Dissipation	P_D	1.50	W	When mounted on a 70×60 mm glass-epoxy board (with a 1310 mm^2 copper area)
Junction Temperature	T_J	-40 to $+150$	$^\circ\text{C}$	
Storage Temperature	T_{stg}	-40 to $+150$	$^\circ\text{C}$	
Thermal Resistance (Junction to Lead (4 pins))	θ_{j-c}	25	$^\circ\text{C}/\text{W}$	
Thermal Resistance (Junction to Ambient Air)	θ_{j-a}	67	$^\circ\text{C}/\text{W}$	When mounted on a 70×60 mm glass-epoxy board (with a 1310 mm^2 copper area)

■ Recommended Operating Conditions

Parameter	Symbol	Ratings	Unit
Input Voltage Range	V_{IN}	4.5 or $V_O + 3^*$ to 18	V
Output Current Range	I_O	0 to 2.0	A
Output Voltage Range	V_O	0.8 to 14	V
Operating Temperature Range	T_{op}	-40 to $+85$	$^\circ\text{C}$

*: The minimum value of the input voltage range is 4.5 V or $V_O + 3$ V, whichever is higher.

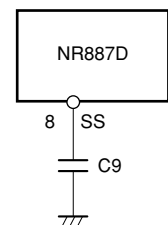

External Dimensions (DIP8)

(Unit : mm)

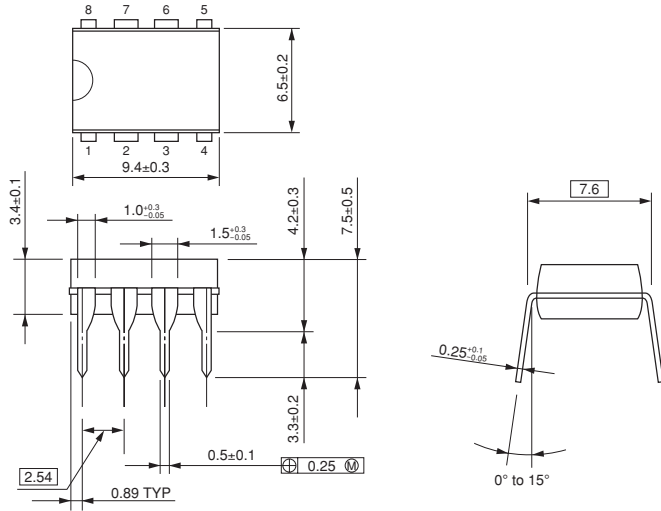

Pin Assignment

- ① BS
- ② VIN
- ③ SW
- ④ GND
- ⑤ FB
- ⑥ NC
- ⑦ EN
- ⑧ SS

Plastic Mold Package Type
 Flammability: UL 94V-0
 Product Mass: Approx. 0.49g

Block Diagram

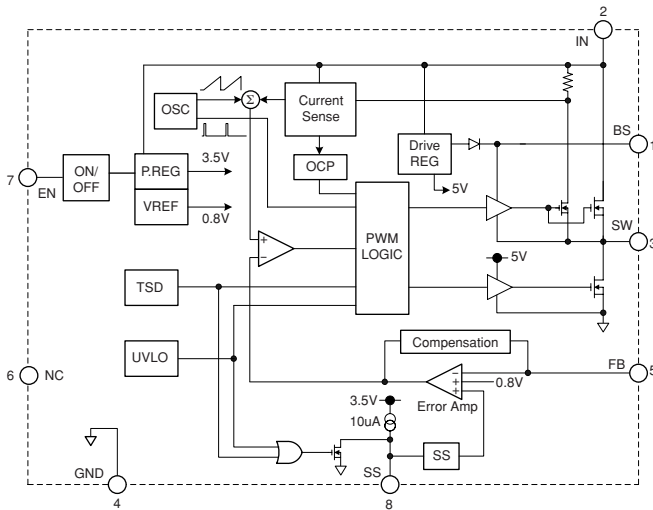

Typical Connection Diagram

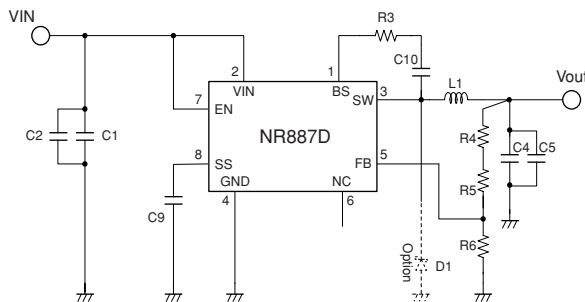

- C1, C2: 10µF/25V
- C4, C5: 22µF/16V
- C9: 0.1µF
- C10: 0.1µF
- L1: 10µH
- R3: 20Ω to 47Ω
- R4+R5: 5kΩ (Vo=3.3V)
- R6: 1.6kΩ

SI-8000S Series Full-Mold, Separate Excitation Step-down Switching Mode

Features

- Compact full-mold package (equivalent to TO220)
- Output current: 3.0A
- High efficiency: 79 to 91%
- Requires only 4 discrete components
- Internally-adjusted phase compensation and output voltage
- Built-in reference oscillator (60kHz)
- Built-in overcurrent and thermal protection circuits
- Built-in soft start circuit (Output ON/OFF available)

Lineup

Part Number	SI-8033S	SI-8050S	SI-8090S	SI-8120S	SI-8150S
Vo(V)	3.3	5.0	9.0	12.0	15.0
Io(A)	3.0				

Absolute Maximum Ratings

Parameter	Symbol	Ratings	Unit
DC Input Voltage	V _{IN}	43 ¹	V
Power Dissipation	P _{D1}	18(With infinite heatsink)	W
	P _{D2}	1.5(Without heatsink, stand-alone operation)	W
Junction Temperature	T _j	+125	°C
Storage Temperature	T _{stg}	-40 to +125	°C
SW Terminal Applied Reverse Voltage	V _{sw}	-1	V
Thermal Resistance(junction to case)	θ _{J-C}	5.5	°C/W

¹35V for SI-8033S

Applications

- Power supplies for telecommunication equipment
- Onboard local power supplies

Recommended Operating Conditions

Parameter	Symbol	Ratings					Unit
		SI-8033S	SI-8050S	SI-8090S	SI-8120S	SI-8150S	
DC Input Voltage Range	V _{IN}	5.5 to 28	7 to 40	12 to 40	15 to 40	18 to 40	V
Output Current Range	I _o	0 to 3.0					A
Operating Junction Temperature Range	T _{OP}	-30 to +125					°C

Electrical Characteristics

(T_a=25°C)

Parameter	Symbol	Ratings															Unit
		SI-8033S			SI-8050S			SI-8090S			SI-8120S			SI-8150S			
		min.	typ.	max.	min.	typ.	max.	min.	typ.	max.	min.	typ.	max.	min.	typ.	max.	
Output Voltage	SI-8000S ¹	3.17	3.30	3.43	4.80	5.00	5.20	8.55	9.00	9.45	11.50	12.00	12.50	14.25	15.00	15.75	V
	SI-8000SS	3.234	3.30	3.366	4.90	5.00	5.10										
	Conditions	V _{IN} =15V, I _o =1.0A			V _{IN} =20V, I _o =1.0A			V _{IN} =21V, I _o =1.0A			V _{IN} =24V, I _o =1.0A			V _{IN} =25V, I _o =1.0A			
Efficiency	η	79			84			88			90			91			%
	Conditions	V _{IN} =15V, I _o =1.0A			V _{IN} =20V, I _o =1.0A			V _{IN} =21V, I _o =1.0A			V _{IN} =24V, I _o =1.0A			V _{IN} =25V, I _o =1.0A			
Oscillation Frequency	f	60			60			60			60			60			kHz
	Conditions	V _{IN} =15V, I _o =1.0A			V _{IN} =20V, I _o =1.0A			V _{IN} =21V, I _o =1.0A			V _{IN} =24V, I _o =1.0A			V _{IN} =25V, I _o =1.0A			
Line Regulation	ΔV _{OLINE}	25 80			40 100			50 120			60 130			60 130			mV
	Conditions	V _{IN} =8 to 28V, I _o =1.0A			V _{IN} =10 to 30V, I _o =1.0A			V _{IN} =15 to 30V, I _o =1.0A			V _{IN} =18 to 30V, I _o =1.0A			V _{IN} =21 to 30V, I _o =1.0A			
Load Regulation	ΔV _{OLOAD}	10 30			10 40			10 40			10 40			10 40			mV
	Conditions	V _{IN} =15V, I _o =0.5 to 1.5A			V _{IN} =20V, I _o =0.5 to 1.5A			V _{IN} =21V, I _o =0.5 to 1.5A			V _{IN} =24V, I _o =0.5 to 1.5A			V _{IN} =25V, I _o =0.5 to 1.5A			
Temperature Coefficient of Output Voltage	ΔVo/ΔTa	±0.5			±0.5			±1.0			±1.0			±1.0			mV/°C
Overcurrent Protection Starting Current	I _{st}	3.1			3.1			3.1			3.1			3.1			A
	Conditions	V _{IN} =15V			V _{IN} =20V			V _{IN} =21V			V _{IN} =24V			V _{IN} =25V			
Soft Start Pin ²	Low-Level Voltage	V _{SSL}			0.2			0.2			0.2			0.2			V
	Outflow Current at Low Voltage	I _{SSL}	15	25	35	15	25	35	15	25	35	15	25	35	15	25	
	Conditions	V _{SSL} =0.2V															μA

¹:"S" may be printed to the right of the marking (except SI-8090S, SI-8120S, SI-8150S).

²:Pin 5 is a soft start pin. Soft start at power on can be performed with a capacitor connected to this pin.

The output can also be turned ON/OFF with this pin.

The output is stopped by setting the voltage of this pin to V_{SSL} or lower.

Soft-start pin voltage can be changed with an open-collector drive circuit of a transistor.

When using both the soft-start and ON/OFF functions together, the discharge current from C₃ flows into the ON/OFF control transistor. Therefore, limit the current securely to protect the transistor if C₃ capacitance is large.

The ON/OFF pin is pulled up to the power supply in the IC, so applying the external voltage is prohibited.

If this pin is not used, leave it open.



V_{OUT}. ON/OFF



Soft start



Soft start +V_{OUT}. ON/OFF

External Dimensions (TO220F-5)

(Unit : mm)



Pin Assignment

- ① VIN
- ② SWout
- ③ GND
- ④ Vos
- ⑤ S.S

Plastic Mold Package Type
 Flammability: UL94V-0
 Product Mass: Approx. 2.3g

Block Diagram



Typical Connection Diagram

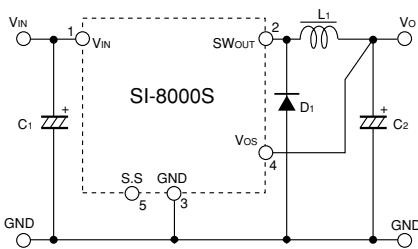

- C_{1,2} : 1000μF
- L₁ : 150μH
- D₁ : RK46(Sanken)

T_a-P_d Characteristics

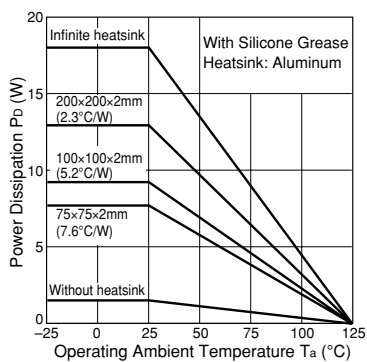

$$P_D = V_o \cdot I_o \left(\frac{100}{\eta \chi} - 1 \right) - V_F \cdot I_o \left(1 - \frac{V_o}{V_{IN}} \right)$$

The efficiency depends on the input voltage and the output current. Therefore, obtain the value from the efficiency graph and substitute the percentage in the formula above.

- V_o : Output voltage
- V_{IN} : Input voltage
- I_o : Output current
- ηχ : Efficiency (%)
- V_F : Diode D₁ forward voltage
0.5V(RK46)

Thermal design for D₁ must be considered separately.

SI-8100QL Series Current Mode Control Step-down Switching Mode

■Features

- DIP8 package
- Introduction of current mode control method
- Output current: 3.5A
- High efficiency: 90% (Vo=5V)
- Built-in reference oscillator (350kHz)
- Built-in drooping-type overcurrent and thermal protection circuits
- Built-in soft start circuit
- Built-in on/off function (Active Hi)
- Low current consumption during off

■Applications

- DVD recorder, FPD-TV
- Onboard local power supplies
- OA equipment

■Absolute Maximum Ratings

Parameter	Symbol	Ratings	Unit	Conditions
Input Voltage	V _{IN}	30	V	
Power Dissipation ^{*1}	P _D	1.56	W	When mounted on glass-epoxy board measuring 70x60 mm (copper laminate area: 1310 mm ²)
Junction Temperature ^{*2}	T _j	-30 to +150	°C	
Storage Temperature	T _{stg}	-40 to +150	°C	
Thermal Resistance (Junction to Case)	θ _{j-c}	25	°C/W	
Thermal Resistance (Junction to Ambient Air)	θ _{j-a}	64	°C/W	When mounted on glass-epoxy board measuring 70x60 mm (copper laminate area: 1310 mm ²)

*1: Limited by thermal protection circuit

*2: Note that the detect temperature for thermal protection is about 140°C.

■Recommended Operating Conditions

Parameter	Symbol	Ratings		Unit	Conditions
		SI-8105QL			
Input Voltage Range	V _{IN}	Vo+3 ^{*1} to 28		V	
Output Voltage Range	Vo	0.5 to 24		V	
Output Current Range	Io	0 to 3.5		A	
Operating Junction Temperature Range	T _{jop}	-30 to +125		°C	
Operating Temperature Range	Top	-30 to +85		°C	

*1: The minimum value of the input voltage range is 4.75 V or Vo +3 V, whichever is higher.

■Electrical Characteristics

(When Ta=25°C and Vo=5V)

Parameter	Symbol	Ratings			Unit
		SI-8105QL			
		min.	typ.	max.	
Reference Voltage	V _{ADJ}	0.485	0.500	0.515	V
	Conditions	V _{IN} =12V, I _o =1A			
Temperature Coefficient of Reference Voltage	(ΔV _{ADJ} /ΔT)		0.05		mV/°C
	Conditions	V _{IN} =12V, I _o =1A, Ta=-40 to +85°C			
Efficiency	η		90		%
	Conditions	V _{IN} =12V, I _o =1A			
Oscillation Frequency	f _o	315	350	385	kHz
	Conditions	V _{IN} =16V, I _o =1A			
Line Regulation	ΔV _{LINE}		30	60	mV
	Conditions	V _{IN} =8 to 28V, I _o =1A			
Load Regulation	ΔV _{LOAD}		30	60	mV
	Conditions	V _{IN} =12V, I _o =0.1 to 3.5A			
Overcurrent Protection Starting Current	I _s	3.6		6.0	A
	Conditions	V _{IN} =12V			
Quiescent Circuit Current	I _q		18		mA
	Conditions	V _{IN} =12V, I _o =0A, V _{EN} =open			
	I _{q(OFF)}			20	μA
Conditions	V _{IN} =12V, I _o =0A, V _{EN} =0V				
SS Pin	Outflow Current at Low Voltage	I _{SSL}	5		μA
		Conditions	V _{IN} =12V, V _{SSL} =0V		
EN Pin	High Level Voltage	V _{C/EH}	2.8		V
		Conditions	V _{IN} =12V		
	Low Level Voltage	V _{C/EL}		2.2	V
Inflow Current at Low Voltage	I _{C/EH}		5		μA
		Conditions	V _{EN} =0V		
Error Amplifier Voltage Gain	AEA		1000		V/V
Error Amplifier Transformer Conductance	GEA		800		μA/V
Current Sense Amplifier Impedance	1/GCS		0.35		V/A
Maximum ON Duty	D _{MAX}		92		%
Minimum ON Time	D _{MIN}		100		nsec.

*: Pin 8 is the SS pin. Soft start at power on can be performed with a capacitor connected to this pin. The SS pin is pulled up to the power supply in the IC, so applying the external voltage is prohibited.

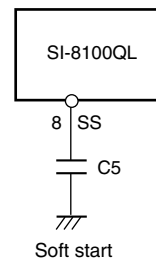

External Dimensions (DIP8)

(Unit : mm)

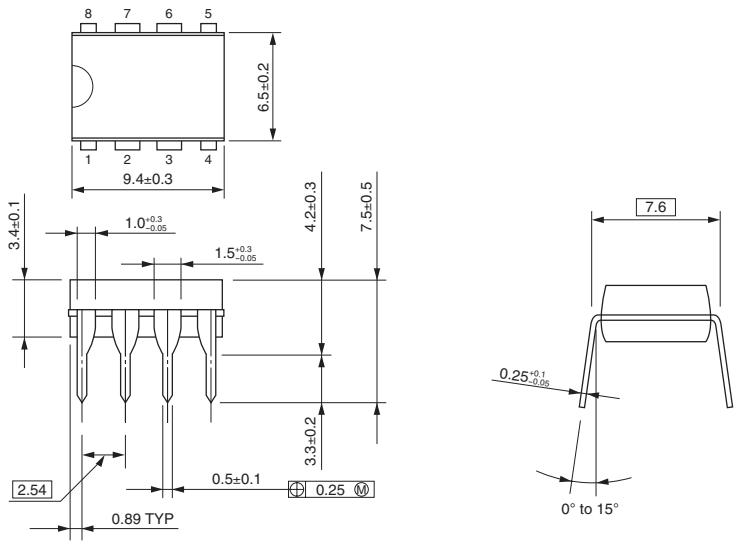

Pin Assignment

- ① BS
- ② IN
- ③ SW
- ④ GND
- ⑤ FB
- ⑥ COMP
- ⑦ EN
- ⑧ SS

Plastic Mold Package Type
 Flammability: UL 94V-0
 Product Mass: Approx. 0.49 g

Block Diagram



Typical Connection Diagram



- C1:10 μ F/50V
(Murata: GRM55DB31H106KA87)
- C2:22 μ F/16V
(Murata: GRM32ER71A226KE20)
- C3:560pF¹
(Murata: GRM18 Type)
- C4:10nF
(Murata: GRM18 Type)
- C5:10nF
(Murata: GRM18 Type)
- L1:10 μ H
- D1:SJPW-T4 (Sanken)
- R1:46k Ω (When $V_O = 5V$)
- R2:5.1k Ω
- R3:24k Ω ¹

¹: When $V_O=5V$

SI-8000FFE Series Full-Mold, Separate Excitation Step-down Switching Mode

Features

- Compact full-mold package (equivalent to TO220)
- Output current: 3.5 A
- High efficiency: 83% ($V_o = 5\text{ V}$, $V_{IN} = 15\text{ V}$, $I_o = 2\text{ A}$)
- Requires only 6 discrete components
- Built-in reference oscillator (300 kHz)
- Built-in drooping-type overcurrent and thermal protection circuits
- Built-in soft start circuit (Output ON/OFF available)

Applications

- DVD recorder, FPD-TV
- OA equipment, such as printers
- Onboard local power supplies

Lineup

Part Number	SI-8001FFE
V_o (V)	Variable (0.8 to 24)
I_o (A)	3.5
Function	Soft start

Absolute Maximum Ratings

Parameter	Symbol	Ratings		Unit	Conditions
		SI-8001FFE			
Input Voltage	V_{IN}	43		V	
Power Dissipation (With infinite heatsink)	P_{D1-1}	22.7		W	Limited by thermal protection circuit, $T_j=150^\circ\text{C}$ $T_j=125^\circ\text{C}$
	P_{D1-2}	18.2			
Power Dissipation (Without heatsink)	P_{D2-1}	2.15		W	Limited by thermal protection circuit, $T_{jmax}=150^\circ\text{C}$ $T_j=125^\circ\text{C}$
	P_{D2-2}	1.72			
Junction Temperature ¹⁾	T_j	+150		$^\circ\text{C}$	
Storage Temperature	T_{stg}	-40 to +150		$^\circ\text{C}$	
Thermal Resistance (Junction to Case)	θ_{j-c}	5.5		$^\circ\text{C}/\text{W}$	
Thermal Resistance (Junction to Ambient Air)	θ_{j-a}	58		$^\circ\text{C}/\text{W}$	

*: This product has built-in thermal protection circuits that may activate when the junction temperature exceeds 130°C . The recommended design for the junction temperature during IC operation is below 125°C .

Recommended Operating Conditions

Parameter	Symbol	Ratings		Unit
		SI-8001FFE		
Input Voltage Range	V_{IN}	V_o+3^1 to 40		V
Output Voltage Range	V_o	0.8 to 24		V
Output Current Range	I_o	0 to 3.5		A
Operating Junction Temperature Range	T_{jop}	-30 to +125		$^\circ\text{C}$
Operating Temperature Range	T_{op}	-30 to +85		$^\circ\text{C}$

*: The minimum value of the input voltage range is 4.5 V or $V_o + 3\text{ V}$, whichever is higher.

Electrical Characteristics

($R_1=4.2\text{k}\Omega$, $R_2=0.8\text{k}\Omega$ when $T_a=25^\circ\text{C}$ and $V_o=5\text{V}$)

Parameter	Symbol	Ratings			Unit
		SI-8001FFE			
		min.	typ.	max.	
Reference Voltage	V_{ADJ}	0.784	0.800	0.816	V
	Conditions	$V_{IN}=15\text{V}$, $I_o=0.2\text{A}$			
Temperature Coefficient of Reference Voltage	$\Delta V_{ADJ}/\Delta T$		± 0.1		$\text{mV}/^\circ\text{C}$
	Conditions	$V_{IN}=15\text{V}$, $I_o=0.2\text{A}$, $T_c=0$ to 100°C			
Efficiency	η		83		%
	Conditions	$V_{IN}=15\text{V}$, $I_o=2\text{A}$			
Oscillation Frequency	f_o	270	300	330	kHz
	Conditions	$V_{IN}=15\text{V}$, $I_o=2\text{A}$			
Line Regulation	ΔV_{OLINE}		55	80	mV
	Conditions	$V_{IN}=10$ to 30V , $I_o=2\text{A}$			
Load Regulation	ΔV_{OLOAD}		15	50	mV
	Conditions	$V_{IN}=15\text{V}$, $I_o=0.2$ to 3.5A			
Overcurrent Protection Starting Current	I_s	3.6			A
	Conditions	$V_{IN}=15\text{V}$			
SS Pin	Low Level Voltage	V_{SSL}		0.5	V
	Outflow Current at Low Voltage	I_{SSL}		6	μA
Quiescent Circuit Current	I_q	Conditions	6		mA
		Conditions	$V_{IN}=15\text{V}$, $I_o=0\text{A}$		
	$I_{q(OFF)}$	Conditions	200		μA
		Conditions	$V_{IN}=15\text{V}$, $V_{SS}=0\text{V}$		

*: Pin 5 is the SS pin. Soft start at power on can be performed with a capacitor connected to this pin. The output can also be turned ON/OFF with this pin.

The output is stopped by setting the voltage of this pin to V_{SSL} or lower. SS-pin voltage can be changed with an open-collector drive circuit of a transistor. When using both the soft-start and ON/OFF functions together, the discharge current from C3 flows into the ON/OFF control transistor. Therefore, limit the current securely to protect the transistor if C3 capacitance is large. The SS pin is pulled up (3.7 V typ.) to the power supply in the IC, so applying the external voltage is prohibited. If this pin is not used, leave it open.

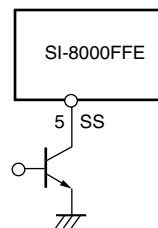

V_o .ON/OFF

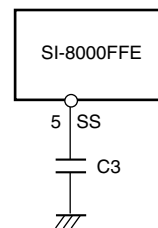

Soft start

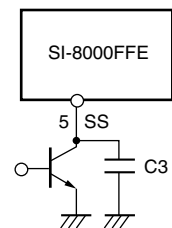

Soft start
+ V_o . ON/OFF

External Dimensions (TO220F-5)

(Unit : mm)



Block Diagram

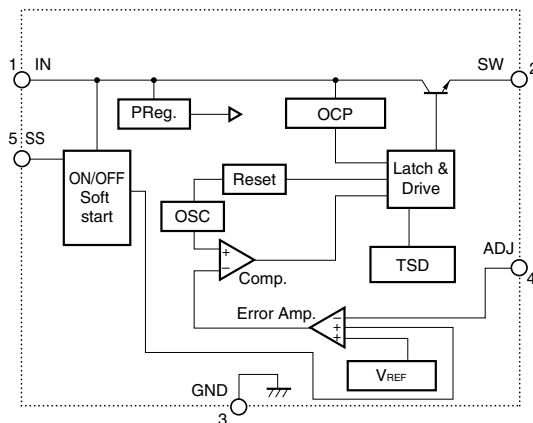

Typical Connection Diagram

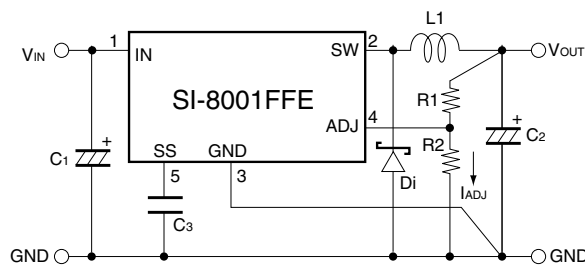

- C1 :470μF
- C2 :680μF
- C3 :0.1μF(Only when using soft-start function)
- L1 :47μH
- D1 :RK46(Sanken)

NR111D Current Mode Control Step-down Switching Mode

Features

- 8pin DIP package
- Input voltage range (V_{IN}): $V_O + 3$ to 31 V
- Oscillation frequency: 350 kHz
- High efficiency under light load
- High efficiency: 94% or higher
- Current mode control
- Stable with low-ESR ceramic output capacitors
- Built-in phase compensation component
- Output current: 4 A
- Reference voltage and accuracy of $0.8 \text{ V} \pm 2\%$
- Adjustable overcurrent threshold
- Output ON/OFF available
- Undervoltage lockout
- Soft start function

Applications

- Power supply for LCDTV, STB and Blu-Ray
- Power supplies for domestic appliances
- On-board local power supply
- Switching power supplies

Absolute Maximum Ratings

Parameter	Symbol	Ratings		Unit	Conditions
		NR111D			
Input Voltage	V_{IN}	35		V	
BS Pin Voltage	V_{BS}	44		V	
Pin Voltage between BS and SW	V_{BS-SW}	8		V	
SW Pin Voltage	V_{SW}	35		V	
FB Pin Voltage	V_{FB}	5.5		V	
EN Pin Voltage	V_{EN}	35		V	
SS Pin Voltage	V_{SS}	5.5		V	
Power Dissipation	P_D	1.47		W	When mounted on 70 × 60 mm glass-epoxy board (with a 1310 mm ² copper area)
Junction Temperature	T_J	-30 to +150		°C	
Storage Temperature	T_{stg}	-40 to +150		°C	
Thermal Resistance (Junction to Lead (4 pins))	θ_{j-c}	41		°C/W	
Thermal Resistance (Junction to Ambient Air)	θ_{j-a}	85		°C/W	When mounted on 70 × 60 mm glass-epoxy board (with a 1310 mm ² copper area)

Recommended Operating Conditions

Parameter	Symbol	Ratings		Unit
		NR111D		
Input Voltage Range	V_{IN}	6.5 or $V_O + 3^*$ to 31		V
Output Current Range	I_{OUT}	0 to 4.0**		A
Output Voltage Range	V_O	0.8 to 24		V
Operating Temperature Range	T_{op}	-40 to 85**		°C

*: The minimum value of the input voltage range is indicated value or $V_O + 3 \text{ V}$, whichever is higher.

** : The device must be used within the range indicated by the T_a - P_D characteristics.

Electrical Characteristics

($T_a=25^\circ\text{C}$, $V_{IN}=12\text{V}$, $V_O=5.0\text{V}$, and $I_O=1\text{A}$, unless otherwise specified)

Parameter	Symbol	Ratings			Unit	Conditions	
		NR111D					
		min.	typ.	max.			
Reference Voltage	V_{REF}	0.784	0.800	0.816	V		
Temperature Coefficient of Output Voltage	$\Delta V_{REF}/\Delta T$		± 0.05		mV/°C	$T_a=-40^\circ\text{C}$ to $+85^\circ\text{C}$	
Oscillation Frequency	f_{sw}		350		kHz		
Line Regulation	V_{LINE}		50		mV	$V_{IN}=V_{INmin}$ to 30V	
Load Regulation	V_{Load}		50		mV	$V_{IN}=12\text{V}$, $V_O=5.0\text{V}$, $I_O=0.1$ to I_{Omax}	
Overcurrent Protection Starting Current	I_{s1}		1.5		A	ISET=OPEN	
	I_{s2}		5.5		A	ISET=SHORT	
No-load Circuit Current	I_{IN}		1		mA	$V_{EN}=10\text{k}\Omega$ pull up to V_{IN}	
Quiescent Circuit Current	$I_{IN(off)}$		1		μA	$I_O=0\text{A}$, $V_{EN}=0\text{V}$	
SS Pin	Outflow Current at Low Voltage	$I_{EN/SS}$	6	10	14	μA	$V_{SS}=0\text{V}$
EN Pin	Inflow Current	I_{EN}		20	50	μA	$V_{EN}=10\text{V}$
	On Threshold Voltage	$V_{C/EH}$	0.7	1.4	2.1	V	
ISET Pin	Open Voltage	V_{ISET}		1.5		V	
Maximum ON Duty	D_{MAX}		90		%		
Minimum ON Time	$T_{ON(MIN)}$		150		nsec		
Thermal Protection Start Temperature	T_{SD}	151	165		°C		
Thermal Protection Return Hysteresis	T_{SD_hys}		20		°C		
SW MOSFET ON Resistance	R_{onH}		105		$\text{m}\Omega$		

*: Pin 8 is the SS pin. Soft start at power on can be performed with a capacitor connected to this pin. The SS pin is pulled up to the power supply in the IC, so applying the external voltage is prohibited.

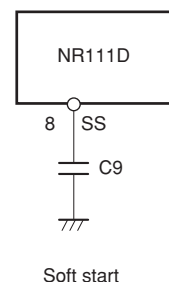

External Dimensions (DIP8)

(Unit : mm)

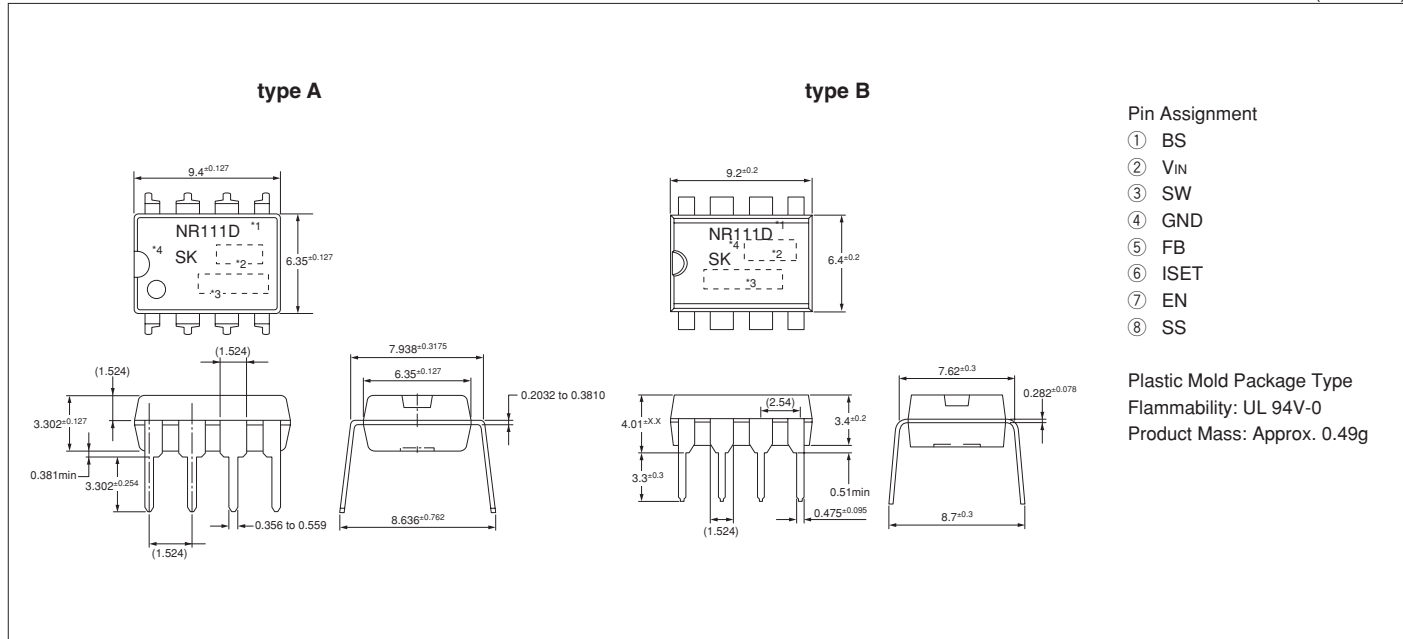

Block Diagram

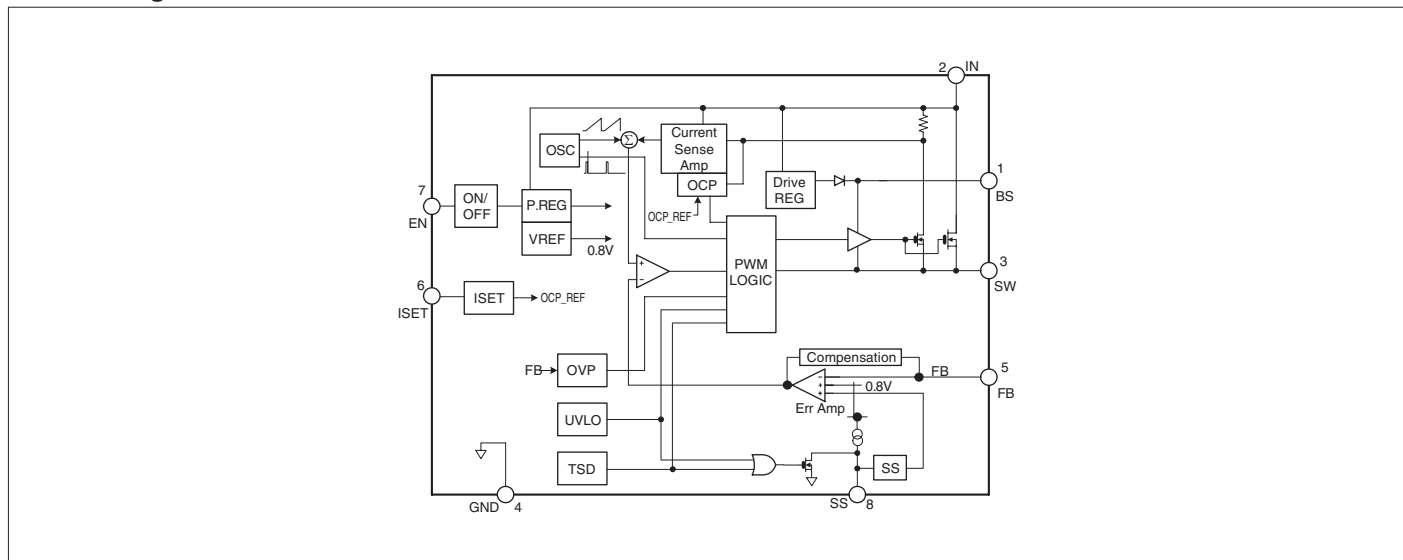

Typical Connection Diagram

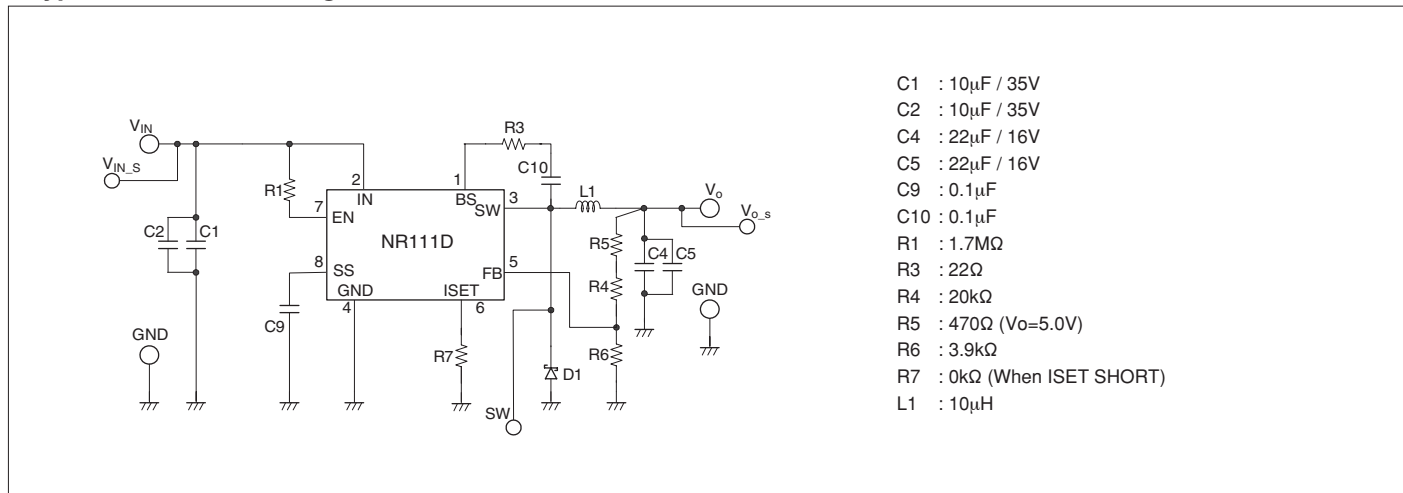

SI-8000HFE Series Full-Mold, Separate Excitation Step-down Switching Mode

■Features

- Compact full-mold package (equivalent to TO220)
- Output current: 5.5 A
- High efficiency: 83% typ. (at $V_o = 5\text{ V}$)
- Requires only 4 discrete components
- Built-in reference oscillator (150 kHz)
- Built-in drooping-type-overcurrent and thermal protection circuits
- Built-in soft start circuit (Output ON/OFF available)

■Applications

- Onboard local power supplies
- OA equipment

■Lineup

Part Number	SI-8008HFE	SI-8050HFE
V_o (V)	Variable (0.8 to 15)	5
I_o (A)		5.5

■Absolute Maximum Ratings

Parameter	Symbol	Ratings	Unit	Conditions
DC Input Voltage	V_{IN}	43	V	
Power Dissipation	P_{D1-1}	25 (with infinite heatsink)	W	Limited by thermal protection, $T_{jmax}=150^\circ\text{C}$
	P_{D1-2}	20 (with infinite heatsink)		$T_{jmax}=125^\circ\text{C}$
	P_{D2-1}	2.15 (without heat sink, standalone operation)		Limited by thermal protection, $T_{jmax}=150^\circ\text{C}$
	P_{D2-2}	1.72 (without heatsink, standalone operation)		$T_{jmax}=125^\circ\text{C}$
Junction Temperature*	T_j	+150	$^\circ\text{C}$	
Storage Temperature	T_{stg}	-40 to +150	$^\circ\text{C}$	
Thermal Resistance (Junction to Case)	θ_{j-c}	5	$^\circ\text{C/W}$	
Thermal Resistance (Junction to Ambient Air)	θ_{j-a}	58	$^\circ\text{C/W}$	

*: This product has built-in thermal protection circuits that may operate when the junction temperature rises above 130°C . The recommended design for the junction temperature during operation is below 125°C .

■Recommended Operating Conditions

Parameter	Symbol	Ratings		Unit
		SI-8008HFE	SI-8050HFE	
Input Voltage Range	V_{IN}	V_o+3^{*1} to 40	8 to 40	V
Output Voltage Range	V_o	0.8 to 24	5.0	V
Output Current Range	I_o		0 to 5.5	A
Operating Junction Temperature Range	T_{jop}		-30 to +125	$^\circ\text{C}$
Operating Temperature Range	T_{op}		-30 to +85	$^\circ\text{C}$

*1: The minimum value of an input voltage range is the higher of 4.5 V or $V_o + 3\text{ V}$.

■Electrical Characteristics

($T_a=25^\circ\text{C}$)

Parameter	Symbol	Ratings			Ratings			Unit	
		SI-8008HFE (at $V_o = 5\text{ V}$)			SI-8050HFE				
		min.	typ.	max.	min.	typ.	max.		
Output Voltage	V_o				4.90	5.00	5.10	V	
Reference Voltage	V_{ADJ}	0.784	0.800	0.816				V	
	Conditions	$V_{IN}=15\text{V}, I_o=1\text{A}$			$V_{IN}=15\text{V}, I_o=1\text{A}$				
Temperature Coefficient of Output Voltage	$\Delta V_o/\Delta T$					± 0.5		$\text{mV}/^\circ\text{C}$	
	Conditions	$V_{IN}=15\text{V}, I_o=1\text{A}, T_c=0$ to 100°C			$V_{IN}=15\text{V}, I_o=1\text{A}, T_c=0$ to 100°C				
Efficiency	η		83			83		%	
	Conditions	$V_{IN}=15\text{V}, I_o=3\text{A}$			$V_{IN}=15\text{V}, I_o=3\text{A}$				
Oscillation Frequency	f_o		150			150		kHz	
	Conditions	$V_{IN}=15\text{V}, I_o=3\text{A}$			$V_{IN}=15\text{V}, I_o=3\text{A}$				
Line Regulation	ΔV_{OLINE}		60	80		60	80	mV	
	Conditions	$V_{IN}=10$ to $30\text{V}, I_o=3\text{A}$			$V_{IN}=10$ to $30\text{V}, I_o=3\text{A}$				
Load Regulation	ΔV_{LOAD}		20	50		20	50	mV	
	Conditions	$V_{IN}=15\text{V}, I_o=0.2$ to 5.5A			$V_{IN}=15\text{V}, I_o=0.2$ to 5.5A				
Overcurrent Protection Starting Current	I_s	5.6			5.6			A	
	Conditions	$V_{IN}=15\text{V}$			$V_{IN}=15\text{V}$				
ON/OFF Pin*	Low Level Voltage	V_{SSL}		0.5			0.5	V	
	Outflow Current at Low Voltage	I_{SSL}		10	30		10	30	μA
		Conditions	$V_{SSL}=0\text{V}$			$V_{SSL}=0\text{V}$			
Quiescent Circuit Current	I_q		6			6		mA	
		Conditions	$V_{IN}=15\text{V}, I_o=0\text{A}$			$V_{IN}=15\text{V}, I_o=0\text{A}$			
	$I_{q(OFF)}$		200	400		200	400	μA	
	Conditions	$V_{IN}=15\text{V}, V_{SS}=0\text{V}$			$V_{IN}=15\text{V}, V_{SS}=0\text{V}$				

*: Pin 5 is the SS pin. Soft start at power on can be performed with a capacitor connected to this pin. The output can also be turned ON/OFF with this pin. The output is stopped by setting the voltage of this pin to V_{SSL} or lower. SS-pin voltage can be changed with an open-collector drive circuit of a transistor. When using both the soft-start and ON/OFF functions together, the discharge current from C3 flows into the ON/OFF control transistor. Therefore, limit the current securely to protect the transistor if C3 capacitance is large. The SS pin is pulled up to the power supply in the IC, so applying the external voltage is prohibited. If the pin is not used, leave it open.

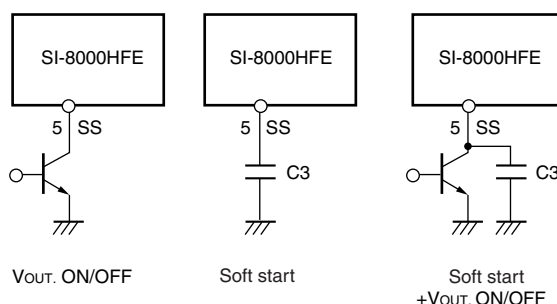

External Dimensions (TO220F-5)

(Unit : mm)



Pin Assignment

- ① VIN
- ② SW
- ③ GND
- ④ ADJ (Vos for SI-8050HFE)
- ⑤ SS

Plastic Mold Package Type
 Flammability: UL94V-0
 Product Mass: Approx. 2.3g

Block Diagram



Typical Connection Diagram



- C1 : 1500 μ F
- C2 : 1000 μ F
- C3 : 1 μ F (Only when using soft-start function)
- C4 : 4.7 μ F (RPER11H475K5 (Murata Manufacturing) recommended)
- L1 : 100 μ H
- Di : FMB-G16L (Sanken)

SI-8000Y Series Current Mode Control Step-down Switching Mode

Features

- Compact (equivalent to TO220) full-mold package
- Output current: 8.0 A
- High efficiency: 86%
- Built-in reference oscillator (130 kHz)
- Built-in drooping-type-overcurrent protection and thermal protection circuits
- Built-in soft start circuit (Output ON/OFF available)
- Low current consumption during off

Absolute Maximum Ratings

Parameter	Symbol	Ratings	Unit
Input Voltage	V_{IN}	45	V
Power Dissipation	P_{D1}	20.8(With infinite heatsink)	W
	P_{D2}	1.8(Without heatsink, stand-alone operation)	W
Junction Temperature	T_j	-30 to +150	°C
Storage Temperature	T_{stg}	-40 to +150	°C
Thermal Resistance (Junction to Case)	θ_{j-c}	6	°C/W
Thermal Resistance (Junction to Ambient Air)	θ_{j-a}	66.7	°C/W

Applications

- AV equipment
- OA equipment
- Gaming equipment
- Onboard local power supplies

Recommended Operating Conditions

Parameter	Symbol	Ratings		Unit
		SI-8010Y	SI-8050Y	
Input Voltage Range	V_{IN}	8 or V_o+3^* to 43	8 to 43	V
Output Voltage Range	V_o	1 to 15	5	V
Output Current Range	I_o	0 to 8.0		A
Operating Junction Temperature Range	T_{jop}	-30 to +135		°C
Operating Temperature Range	T_{op}	-30 to +85		°C

*: The minimum value of the input voltage range is 8 V or $V_o + 3V$, whichever is higher.

Electrical Characteristics

Parameter	Symbol	Ratings						Unit
		SI-8010Y*			SI-8050Y			
		min.	typ.	max.	min.	typ.	max.	
Output Voltage (Reference voltage for SI-8010Y)	$V_o(V_{REF})$	0.98	1.00	1.02	4.90	5.00	5.10	V
Temperature Coefficient of Output Voltage (Reference voltage temperature coefficient for SI-8010Y)	$\Delta V_o/\Delta T(\Delta V_{REF}/\Delta T)$	± 0.1			± 0.5			mV/°C
	Conditions	$V_{IN}=30V, I_o=0.1A, T_a=0 \text{ to } 100^\circ C$			$V_{IN}=30V, I_o=0.1A, T_a=0 \text{ to } 100^\circ C$			
Efficiency	η	86			86			%
	Conditions	$V_{IN}=30V, I_o=3A$			$V_{IN}=30V, I_o=3A$			
Oscillation Frequency	f_o	130			130			kHz
	Conditions	$V_{IN}=30V, I_o=3A$			$V_{IN}=30V, I_o=3A$			
Line Regulation	ΔV_{OLINE}	30			30			mV
	Conditions	$V_{IN}=10 \text{ to } 43V, I_o=3A$			$V_{IN}=10 \text{ to } 43V, I_o=3A$			
Load Regulation	ΔV_{OLOAD}	30			30			mV
	Conditions	$V_{IN}=30V, I_o=0.1 \text{ to } 8A$			$V_{IN}=30V, I_o=0.1 \text{ to } 8A$			
Overcurrent Protection Starting Current	I_s	8.1			8.1			A
	Conditions	$V_{IN}=20V$			$V_{IN}=20V$			
Quiescent Circuit Current	I_q	8			8			mA
	Conditions	$V_{IN}=30V, I_o=0A, EN/SS=open$			$V_{IN}=30V, I_o=0A, EN/SS=open$			
	$I_{q(OFF)}$	200			200			μA
Conditions	$V_{IN}=30V, EN/SS=0V$			$V_{IN}=30V, EN/SS=0V$				
EN/SS Pin*	Outflow Current at Low Voltage	I_{SSL}	10		10		30	μA
		Conditions	$V_{IN}=30V, EN/SS=0V$		$V_{IN}=30V, EN/SS=0V$			
	Low Level Voltage	V_{SSL}	0.5		0.5		V	
Conditions	$V_{IN}=30V$		$V_{IN}=30V$					
Error Amplifier Voltage Gain	AEA	300			300			V/V
Error Amplifier Transformer Conductance	GEA	800			800			$\mu A/V$
Current Sense Amplifier Impedance	1/GCS	0.16			0.16			V/A
Maximum ON Duty	DMAX	92			92			%
Minimum ON Time	DMIN	200			200			nsec

*: $R1=8k\Omega, R2=2k\Omega$ when $T_a=25^\circ C$ and $V_o=5V$

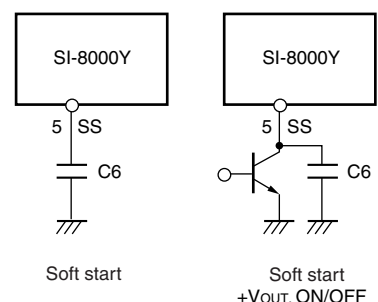

External Dimensions (TO220F-7)

(Unit : mm)



Block Diagram



Typical Connection Diagram



SI-8400L/8500L Series Separate Excitation Step-down Switching Mode with Coil

■Features

- Switching ICs/Coil combined type
- Requires only 2 discrete components
- Low switching noise
- No heatsink required
- Built-in overcurrent and thermal protection circuits
- Built-in soft start circuit (Output ON/OFF available)...SI-8500L Series

■Applications

- Telephone power supplies
- Onboard local power supplies

■Lineup

Part Number	SI-8401L	SI-8501L
V _o (V)	5.0	5.0
I _o (A)	0.5	1.0

■Absolute Maximum Ratings

Parameter	Symbol	Ratings		Unit
		SI-8400L	SI-8500L	
DC Input Voltage	V _{IN}	35		V
Power Dissipation	P _D	1.25	3	W
Junction Temperature	T _J	+100		°C
Storage Temperature	T _{stg}	-25 to +85		°C

■Recommended Operating Conditions

Parameter	Symbol	Ratings		Unit
		SI-8401L		
DC Input Voltage Range	V _{IN}	7 to 33		V
Output Current Range	I _o	0 to 0.5		A
Operating Temperature Range	T _{op}	-20 to +85		°C

Parameter	Symbol	Ratings		Unit
		SI-8501L		
DC Input Voltage Range	V _{IN}	7 to 33		V
Output Current Range	I _o	0 to 1.0		A
Operating Temperature Range	T _{op}	-20 to +85		°C

■Electrical Characteristics

(T_a=25°C)

Parameter	Symbol	Ratings			Unit
		SI-8401L			
		min.	typ.	max.	
Output Voltage	V _o	4.80	5.00	5.20	V
	Conditions	V _{IN} =20V, I _o =0.3A			
Efficiency	η	80			%
	Conditions	V _{IN} =20V, I _o =0.3A			
Oscillation Frequency	f	60			kHz
	Conditions	V _{IN} =20V, I _o =0.3A			
Line Regulation	ΔV _{OLINE}	80			mV
	Conditions	V _{IN} =10 to 30V, I _o =0.3A			
Load Regulation	ΔV _{OLOAD}	30	40		mV
	Conditions	V _{IN} =20V, I _o =0.1 to 0.4A			
Temperature Coefficient of Output Voltage	ΔV _o /ΔT _a	±0.5			mV/°C
Switching Ripple Voltage (C ₂ =470μF)	ΔV _r	20			mV _{p-p}
	Conditions	V _{IN} =20V, I _o =0.3A			
Overcurrent Protection Starting Current	I _{s1}	0.55			A
	Conditions	V _{IN} =10V			

(T_a=25°C)

Parameter	Symbol	Ratings			Unit
		SI-8501L			
		min.	typ.	max.	
Output Voltage	V _o	4.80	5.00	5.20	V
	Conditions	V _{IN} =20V, I _o =0.5A			
Efficiency	η	83			%
	Conditions	V _{IN} =20V, I _o =0.5A			
Oscillation Frequency	f	60			kHz
	Conditions	V _{IN} =20V, I _o =0.5A			
Line Regulation	ΔV _{OLINE}	70			mV
	Conditions	V _{IN} =10 to 30V, I _o =0.5A			
Load Regulation	ΔV _{OLOAD}	30	55		mV
	Conditions	V _{IN} =20V, I _o =0.2 to 0.8A			
Temperature Coefficient of Output Voltage	ΔV _o /ΔT _a	±0.5			mV/°C
Switching Ripple Voltage (C ₂ =470μF)	ΔV _r	45			mV _{p-p}
	Conditions	V _{IN} =20V, I _o =0.5A			
Overcurrent Protection Starting Current	I _{s1}	1.1			A
	Conditions	V _{IN} =18V			

External Dimensions (Non-package type [EI-12.5 core/EI-19 core])

(Unit : mm)

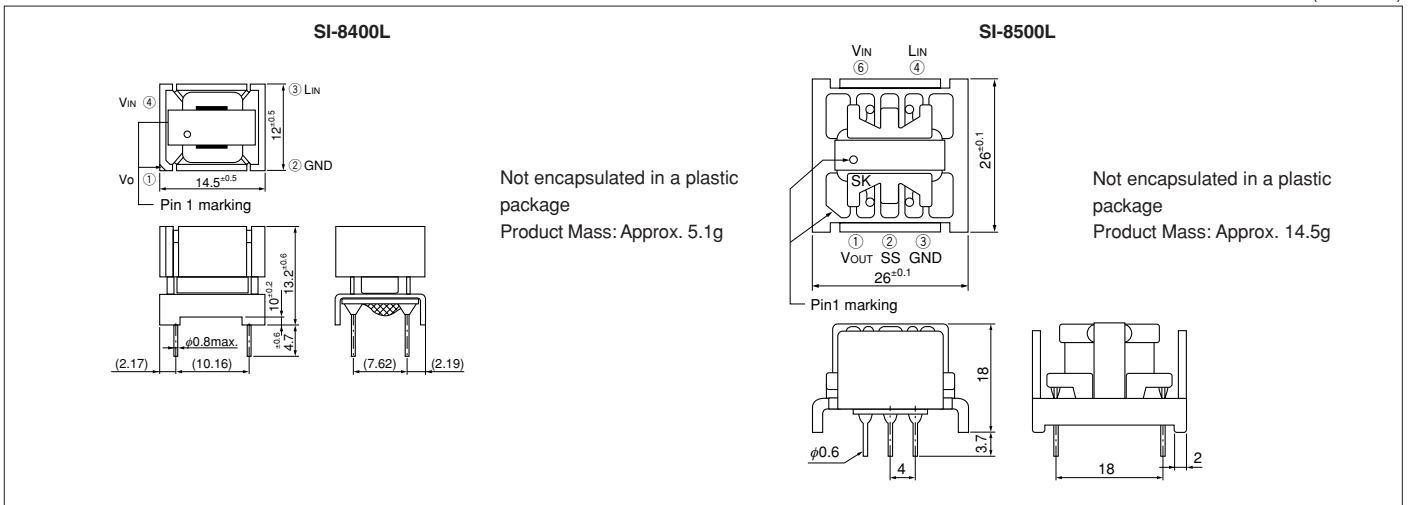

Block Diagram

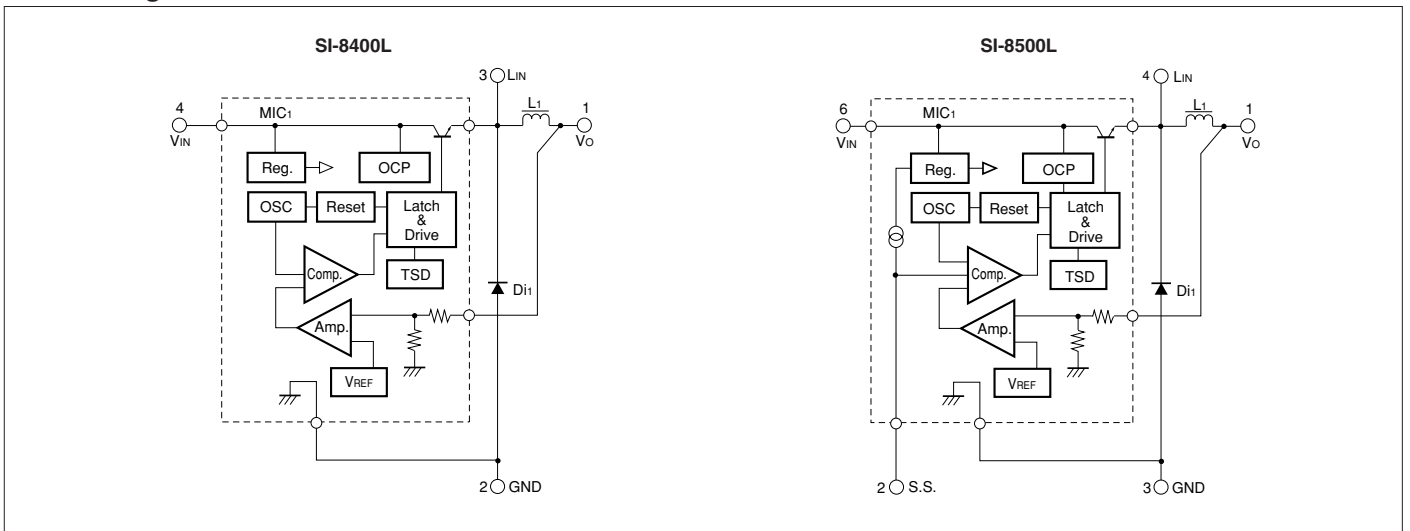

Typical Connection Diagram

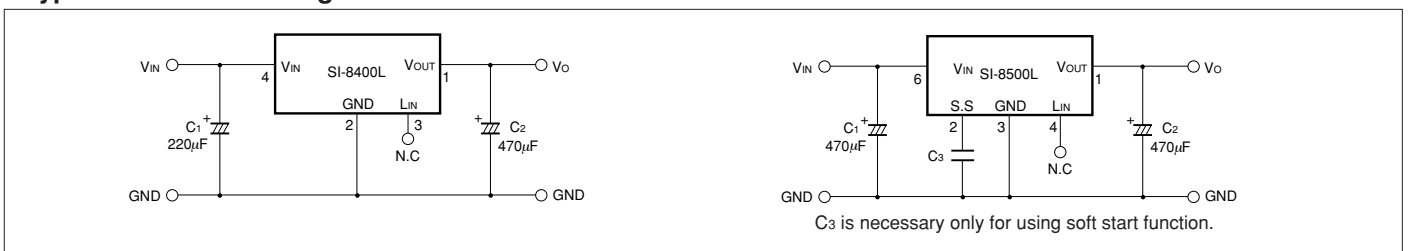

Ta-Pd Characteristics

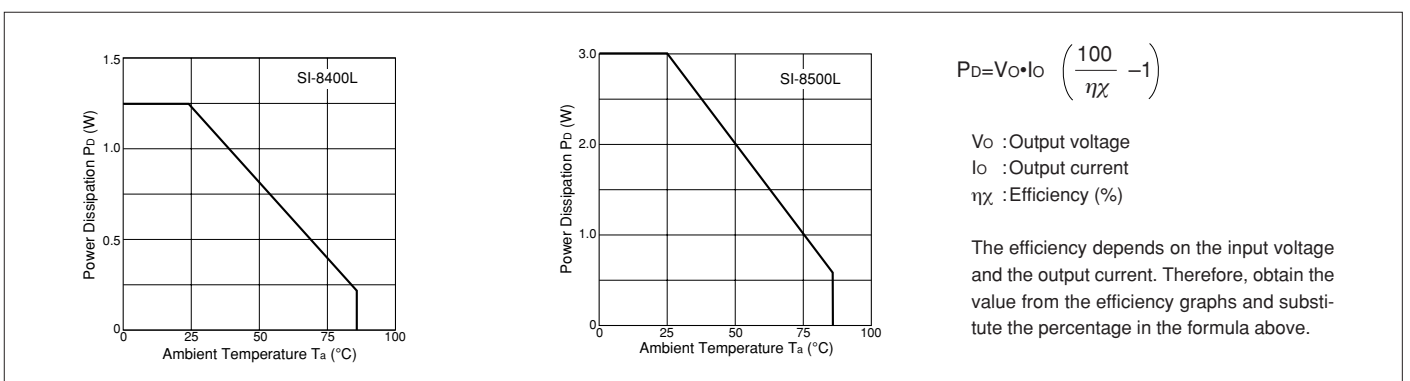

STA801M 2-Output Separate Excitation Step-down Switching Mode

Features

- 2 regulators combined in 1 package
- Compact inline package
- Output current (0.5A × 2 outputs)
- Output voltage of Ch2 selectable from 4 levels
- Built-in flywheel diode (Schottky barrier diode)
- Requires only 7 discrete components (2 outputs)
- Internally-adjusted phase compensations and output voltages
- Built-in reference oscillator (125kHz) - Enables to downsize a choke-coil due to IC's high oscillating frequency. (Compared with conventional Sanken devices)
- Built-in overcurrent and thermal protection circuits
- Built-in soft start circuits (Output ON/OFF available)

Lineup

Part Number	Output Voltage (V)	
	Ch1	Ch2(Select one output)
STA801M	5	9.0 / 11.5 / 12.1 / 15.5

Absolute Maximum Ratings

Parameter	Symbol	Ratings	Unit
DC Input Voltage	V _{IN}	43	V
Power Dissipation	P _{D1}	6.7(With infinite heatsink)	W
	P _{D2}	1.6(Without heatsink, stand-alone operation)	W
Junction Temperature	T _j	+125	°C
Storage Temperature	T _{stg}	-40 to +125	°C

Applications

- For BS and CS antenna power supplies
- For stabilization of the secondary stage of switching power supplies
- Electronic equipment

Recommended Operating Conditions

Parameter	Symbol	Ratings		Unit
		min.	max.	
DC Input Voltage Range	V _{IN}	Ch2 V _{Omax} +2	40	V
Output Current Range per Channel	I _o	0	0.5	A
Operating Temperature Range	T _{top}	-20	+125	°C

Electrical Characteristics

(T_a=25°C)

	Parameter	Symbol	Ratings			Unit
			STA801M			
			min.	typ.	max.	
Ch1	Output voltage 1	V _{O1}	4.80	5.00	5.20	V
		Conditions	V _{IN} =20V, I _o =0.3A			
	Efficiency *	η ₁		80		%
		Conditions	V _{IN} =20V, I _o =0.3A			
	Temperature Coefficient of Output Voltage	ΔV _O /ΔT _{a1}		±0.5		mV/°C
	Line Regulation	ΔV _{OLINE1}		30	90	mV
Conditions		V _{IN} =10 to 30V, I _o =0.3A				
Load Regulation	ΔV _{LOAD1}		10	40	mV	
	Conditions	V _{IN} =20V, I _o =0.1 to 0.4A				
Ch2 (Select one output)	Output voltage 2-1	V _{O2-1}	8.64	9.00	9.36	V
		Conditions	V _{IN} =20V, I _o =0.3A			
	Output voltage 2-2	V _{O2-2}	11.04	11.50	11.96	V
		Conditions	V _{IN} =20V, I _o =0.3A			
	Output voltage 2-3	V _{O2-3}	11.62	12.10	12.58	V
		Conditions	V _{IN} =20V, I _o =0.3A			
	Output voltage 2-4	V _{O2-4}	14.88	15.50	16.12	V
		Conditions	V _{IN} =20V, I _o =0.3A			
	Vo2-4	Efficiency*	η		89	%
			Conditions	V _{IN} =20V, I _o =0.3A		
		Temperature Coefficient of Output Voltage	ΔV _O /ΔT _a		±2.0	
	Line Regulation	ΔV _{OLINE}		40	130	mV
Conditions		V _{IN} =20 to 30V, I _o =0.3A				
Load Regulation	ΔV _{LOAD}		30	120	mV	
	Conditions	V _{IN} =20V, I _o =0.1 to 0.4A				
Common	No-load Circuit Current	I _{cc}		15	mA	
	Oscillation Frequency	f		125	kHz	
	Overcurrent Protection Starting Current	I _{s1}	0.51	0.7	A	

* Efficiency indicates the value when only one channel is active. The value can be calculated as shown below. 7.5mA is deducted for the no-load circuit current of $\frac{I_{cc}}{2}$ at unused output.

$$\eta = \frac{V_O \cdot I_o}{V_{IN} \cdot (I_{IN} - 0.0075)} \times 100(\%)$$

External Dimensions (SIP10 [STA 10Pin])

(Unit : mm)

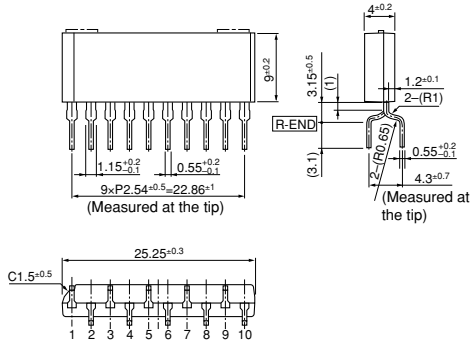

Pin Assignment

- ① Vo2 Cont
 - ② Vos1
 - ③ SS1
 - ④ SWOUT1
 - ⑤ GND
 - ⑥ VIN
 - ⑦ SWOUT2
 - ⑧ SS2
 - ⑨ Vos2-2
 - ⑩ Vos2-1
- Plastic Mold Package Type
 Flammability: UL94V-0
 Product Mass: Approx. 2.5g

Block Diagram

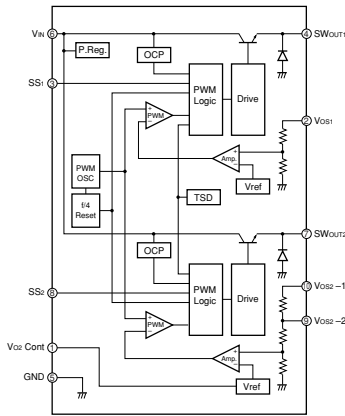

Typical Connection Diagram

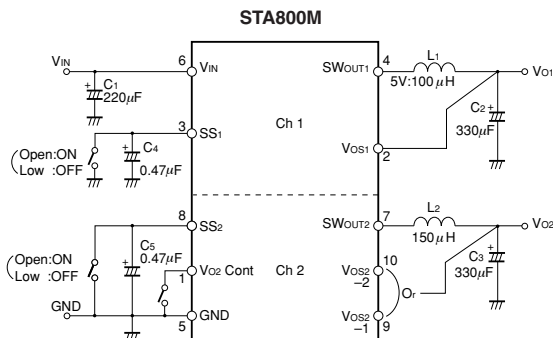

Selection of connection method and output for Vos2-1 and Vos2-2 of Channel 2

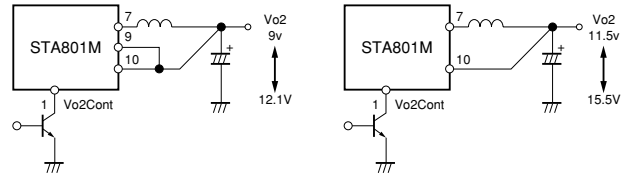

	Vo2Cont Pin	
Vo2 Sensing Pin	Open	Low
Pin 9	9V	12.1V
Pin 10	11.5V	15.5V

Ta-Pd Characteristics

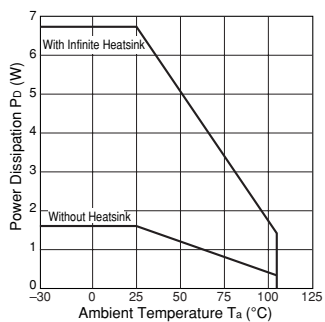

SPI-8001TW/SPI-8002TW/SPI-8003TW 2-Output, Step-down Switching Mode

■ Features

- 2 regulators combined in one package
- Output current: 1.5A × 2 (HSOP 16 Pin Surface mount package)
- High efficiency: TYP80% (SPI-8001TW), TYP78% (SPI-8002TW)
- Variable output voltage: 1.0 to 16V (SPI-8001TW), 1.0 to 24V (SPI-8002TW)
- Built-in reference oscillator (250kHz): Enables to downsize a choke-coil
- Low circuit current consumption: $\leq 1\mu\text{A}$ (at output OFF)
- High accuracy reference voltage: $\pm 1\%$
- Built-in foldback-overcurrent and thermal protection circuits
- Built-in ON/OFF circuit (soft start available) – per output

■ Applications

- Onboard local power supplies
- OA equipment
- For stabilization of the secondary-side output voltage of switching power supplies

■ Absolute Maximum Ratings*1

Parameter	Symbol	Ratings			Unit
		SPI-8001TW	SPI-8002TW	SPI-8003TW	
Input Voltage	V_{IN}	21	40	40	V
	V_{CC}	21	40	40	V
	$V_{C/E}$	21	40	40	V
Power Dissipation*2, *3	P_D	3.0			W
Junction Temperature	T_J	+135		+150	°C
Storage Temperature	T_{stg}	-40 to +135		-40 to +150	°C
Thermal Resistance (junction to case)*2	θ_{j-c}	9.0			°C/W
Thermal Resistance (junction to ambient air)*2	θ_{j-a}	35.8			°C/W

*1: Absolute maximum ratings show the destructive limit. No parameter should exceed the ratings in transient or normal operations.

*2: When mounted on glass-epoxy board 70cm² (copper laminate area 30.8cm²).

*3: Limited by thermal protection.

■ Recommended Operating Conditions*1

Parameter	Symbol	Ratings						Unit
		SPI-8001TW		SPI-8002TW		SPI-8003TW		
		min.	max.	min.	max.	min.	max.	
Input Voltage Range	V_{IN}	V_{O+3}	20	V_{O+3}	38	V_{O+3}	38	V
	V_{CC}	4.5	20	4.5	38	4.5	38	V
	$V_{C/E}$		20		38		38	V
Output Voltage Range	V_O	1	16	1	24	1	24	V
Output Current Range	I_O		1.5		1.5		1.5	A
Operating Junction Temperature Range	T_{jop}	-30	+135	-30	+135	-30	+125	°C
Operating Temperature Range	T_{op}	-30	+135	-30	+135	-30	+85	°C

*1: Recommended operating conditions show the operating conditions required for the normal circuit function described in the electrical characteristics. These conditions must be followed in actual use.

■Electrical Characteristics*1

(Ta=25°C)

Parameter	Symbol	Ratings									Unit	
		SPI-8001TW			SPI-8002TW			SPI-8003TW				
		min.	typ.	max.	min.	typ.	max.	min.	typ.	max.		
Reference Voltage	V _{REF}	0.996	1.006	1.016	0.996	1.006	1.016	0.966	1.006	1.016	V	
	Conditions	V _{IN} =10V, V _O =1V, I _O =0.1A										
Temperature Coefficient of Reference Voltage	ΔV _{REF} /ΔT		±0.1			±0.1			±0.1		mV/°C	
	Conditions	V _{IN} =10V, V _O =1V, I _O =0.1A, Ta=-30 to +135°C						V _{IN} =14V, I _O =0.1A, Ta=-30 to +125°C				
Efficiency 1 ²	Eff1		80			78			78		%	
	Conditions	V _{IN} =V _{CC} =15V, V _O =5V, I _O =0.5A, I _{IN} : including I _{CC}						V _{IN} =V _{CC} =14V, V _O =5V, I _O =0.5A, I _{IN} : including I _{CC}				
Efficiency 2 ²	Eff2		83			81			81		%	
	Conditions	V _{IN} =15V, V _O =5V, I _O =0.5A, V _{CC} =5V, I _{IN} : excluding I _{CC}						V _{IN} =14V, V _{CC} =5V, V _O =5V, I _O =0.5A, I _{IN} : excluding I _{CC}				
Oscillation Frequency	f _{osc}		250		215	250	285	200		400	kHz	
	Conditions	V _{IN} =V _{CC} =15V, V _O =5V, I _O =0.5A						V _{IN} =14V, I _O =0.1A, C _{OSC} =100pF				
Line Regulation	V _{LINE}		30	60		30	60		30	60	mV	
	Conditions	V _{IN} =V _{CC} =10 to 20V, V _O =5V, I _O =1A						V _{IN} =V _{CC} =9 to 18V, V _O =5V, I _O =1A				
Load Regulation	V _{LOAD}		10	40		10	40		10	40	mV	
	Conditions	V _{IN} =V _{CC} =15V, V _O =5V, I _O =0.2 to 1.5A						V _{IN} =V _{CC} =14V, V _O =5V, I _O =0.2 to 1.5A				
Overcurrent Protection Starting Current	I _S	1.6			1.6			1.6			A	
	Conditions	V _{IN} =V _{CC} =15V										
Quiescent Circuit Current 1	I _{IN}		4			4			4		mA	
	Conditions	V _{IN} =15V, V _{CC} =5V, I _O =0V, V _O ≤12V						V _{IN} =14V, V _{CC} =5V, I _O =0A, V _O ≤12V				
Quiescent Circuit Current 2	I _{CC}		8.5			8.5			8.5		mA	
	Conditions	V _{CC} =15V, I _O =0A										
Quiescent Circuit Current 3	I _{IN (off)}		1			1			1		μA	
	Conditions	V _{IN} =15V, V _{C/E} =0V or Open						V _{IN} =14V, V _{C/E} =0V or Open				
Quiescent Circuit Current 4	I _{CC (off)}		1			1			1		μA	
	Conditions	V _{CC} =15V, V _{C/E} =0V or Open						V _{IN} =14V, V _{C/E} =0V or Open				
Quiescent Circuit Current 5	I _{IN (ssov)}		—			—			4		mA	
	Conditions	—						V _{IN} =14V, V _{CC} =5V, I _O =0A, SS1=SS2=0V				
Quiescent Circuit Current 6	I _{CC (ssov)}		—			—			8.5		mA	
	Conditions	—						V _{CC} =14V, I _O =0V, SS1=SS2=0V				
C/E Pin	High Level Voltage	V _{C/EH}	2			2			2		V	
		Conditions	V _{IN} =V _{CC} =15V						V _{IN} =V _{CC} =14V			
	Low Level Voltage	V _{C/EL}			0.8			0.8			0.8	V
		Conditions	V _{IN} =V _{CC} =15V						V _{IN} =V _{CC} =14V			
Inflow Current at High	I _{C/EH}		95			95			95		μA	
	Conditions	V _{C/E} =20V						V _{C/E} =20V				
SS Pin ¹³	Low Level Voltage	V _{SSL}			0.5		0.5			0.5	V	
		Conditions	V _{IN} =V _{CC} =15V						V _{IN} =V _{CC} =14V			
	Inflow Current at Low	I _{SSL}		60	80		60	80		60	80	μA
		Conditions	V _{SSL} =0V, V _{IN} =V _{CC} =15V						V _{SSL} =0V, V _{IN} =V _{CC} =14V			

*1: Electrical characteristics show the characteristic ratings guaranteed when operating the ICs under the measurement conditions described in the above table.

*2: Efficiency is calculated from the following formula.

$$\eta (\%) = \frac{V_O \cdot I_O}{V_{IN} \cdot I_{IN}} \times 100$$

*3: Pin 6 and pin 11 are the SS pins. Soft start at power on can be performed with capacitors connected to these pins. The outputs can also be turned ON/OFF with these pins. The outputs are stopped by setting the voltages of these pins to V_{SSL} or lower. SS-pin voltages can be changed with open-collector drive circuits of transistors.

When using both the soft-start and ON/OFF functions together, the discharge currents from C₄ and C₅ flow into the ON/OFF control transistors respectively. Therefore, limit the currents securely to protect the transistors if C₄ and C₅ capacitances are large. The SS pins are pulled up to the power supply in the ICs, so applying the external voltages are prohibited.

External Dimensions (HSOP16)

(Unit : mm)



Block Diagram

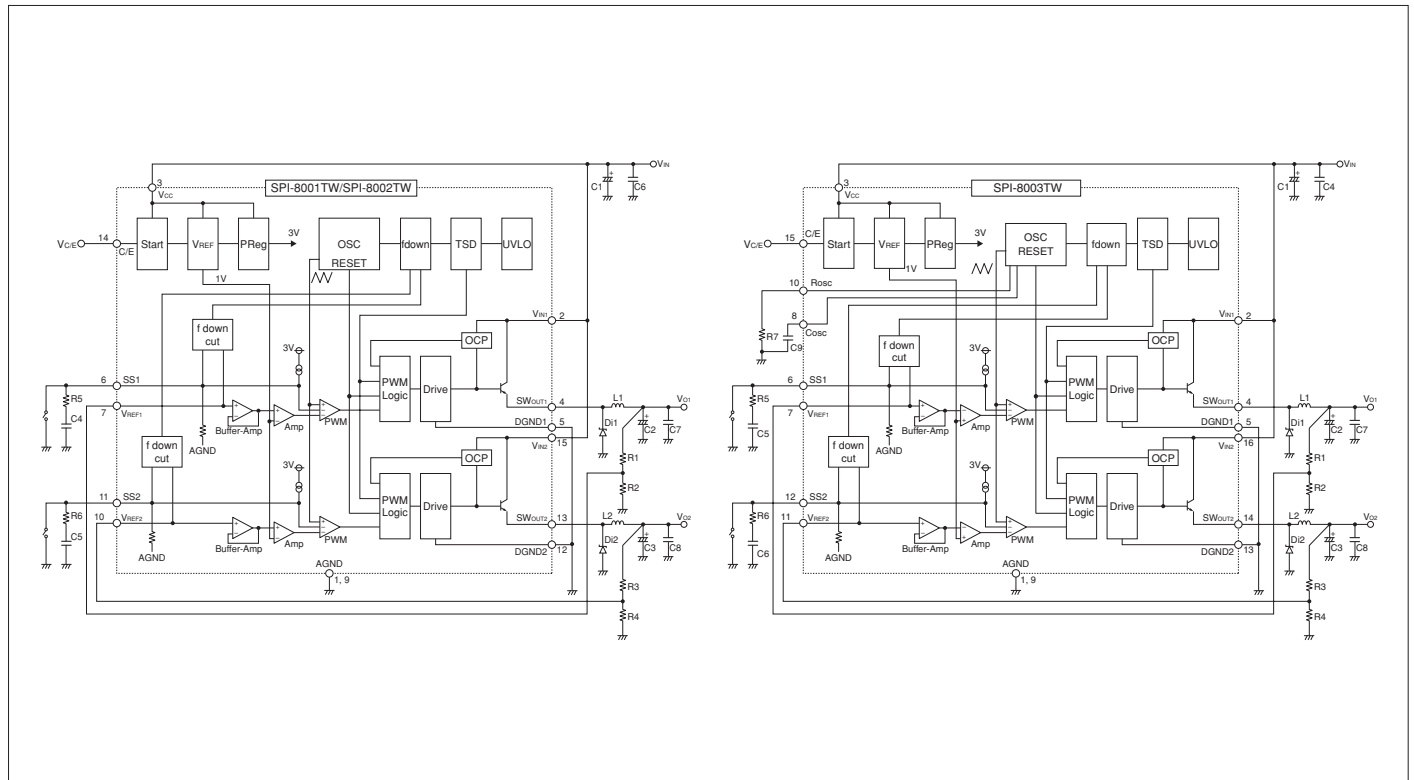

Typical Connection Diagram

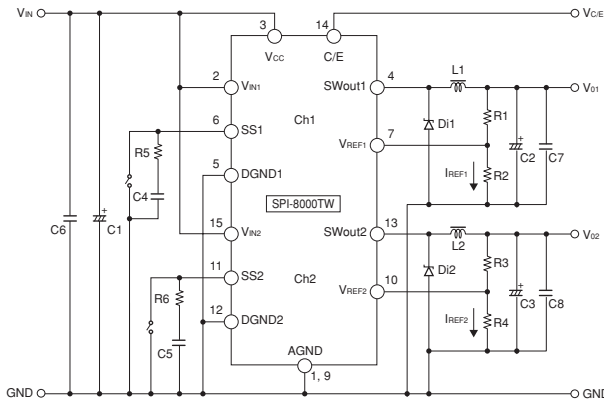

- C1 : 220 μF/50V
- C2, C3 : 470 μF/25V
- C4, C5 : 1 μF
- C6, C7, C8 : 0.1 μF
- R5, R6 : 1kΩ
- L1, L2 : 47 μH
- Di1, Di2 : SJPB-H6 (Sanken)

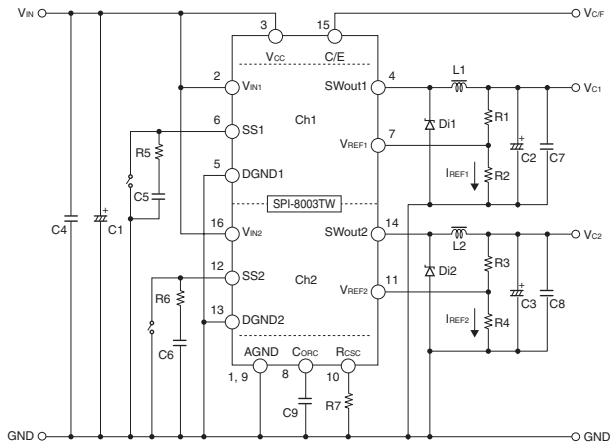

- C1 : 220 μF/50V
- C2, C3 : 470 μF/25V
- C4 : 1 μF/50V
- C5, C6 : 1 μF/10V
- C7, C8 : 0.1 μF/50V
- C9 : 100pF/10V
- L1, L2 : 47 μH
- R2, R4 : 1kΩ
- R5, R6 : 1kΩ
- Di1, Di2 : SJPB-H6 (Sanken)

Diodes Di1, Di2

- Be sure to use Schottky-barrier diodes for Di1 and Di2.
- If other diodes like fast recovery diodes are used, IC may be destroyed because of the reverse voltage generated by the recovery voltage or ON voltage.

Choke coils L1, L2

- If the winding resistance of the choke coil is too high, the efficiency may drop below the rated value.
- As the overcurrent protection starting current is about 2.0A, take care concerning heat radiation from the choke coil caused by magnetic saturation due to overload or short-circuited load.
- Use a closed-magnetic-path coil to prevent interference between the channels SWout1 and SWout2.

Capacitors C1, C2, C3

- As large ripple currents flow through C1, C2 and C3, use high-frequency and low-impedance capacitors suitable for switching mode power supplies. Especially when the impedance of C2 and C3 are high, the switching waveforms may become abnormal at low temperatures. For C2 and C3, do not use capacitors with extremely low equivalent series resistance (ESR) such as OS capacitors or tantalum capacitors, which may cause abnormal oscillation.

Resistors R1, R2, R3, R4

- R1, R2, R3 and R4 are resistors for setting output voltages. Set the resistors so that IREF is approx. 1 mA. For example, R1 and R2 can be calculated as shown below.

$$R1 = \frac{(VO1 - VREF1)}{IREF1} = \frac{(VO1 - V)}{1 \times 10^{-3}} (\Omega), R2 = \frac{VREF1}{IREF1} = \frac{1}{1 \times 10^{-3}} \approx 1(K\Omega)$$

© To create the optimum operating conditions, place the components as close as possible to each other.

Ta-Pd Characteristics



$$P_D = V_O \cdot I_O \left(\frac{100}{\eta\%} - 1 \right) - V_F \cdot I_O \left(1 - \frac{V_O}{V_{IN}} \right)$$

- VO : Output Voltage
- VIN : Input Voltage
- IO : Output Current
- η% : Efficiency (%)
- VF : D1 Forward Voltage
SJPB-H6...0.45V (IO=1A)

Note 1: The efficiency depends on the input voltage and the output current. Therefore, obtain the value from the efficiency graph and substitute the percentage in the formula above.

Note 2: Thermal design for D1 must be considered separately.

SI-8511NVS Surface-Mount, Synchronous Rectifier Step-down Switching Mode Control ICs

■ Features

- Surface-mount package (TSSOP24)
- High efficiency due to synchronous rectification: 92% (at $V_{IN} = 5V$, $I_o = 1A$, $V_o = 2.5V$)
- Capable of downsize a choke-coil due to IC's high switching frequency (400kHz typ, On Time Control). (Compared with conventional Sanken devices)
- Low reference voltage (V_{ref}) of 1.1V. The output voltage is variable from 1.1V to 6V.
- High-speed response to a load
- Compatible with low ESR capacitors
- Soft start and output ON/OFF available
- Built-in overcurrent and output-overvoltage protection circuits
- PWRGD function to indicate the output voltage status
- High precision reference voltage: $1.1V \pm 1.2\%$

■ Absolute Maximum Ratings

(Ta=25°C)

Parameter	Symbol	Ratings	Unit
Control-System DC Input Voltage	V_{CC}	7	V
DC Input Voltage	V_{IN}	25	V
Boost Block Input Voltage	V_H	30	V
EN Terminal Input Voltage	V_{EN}	V_{CC}	V
PWRGD Terminal Applied Voltage	V_{PWRGD}	7	V
Junction Temperature	T_j	+150	°C
Storage Temperature	T_{sig}	-40 to +150	°C

■ Applications

- Power supplies for notebook PCs and mobile devices
- Onboard local power supplies
- OA equipment
- For stabilization of the secondary-side output voltage of switching power supplies

■ Recommended Operating Conditions

Parameter	Symbol	Ratings	Unit
Control System Input Voltage Range	V_{CC}	4.5 to 5.5	V
Input Voltage Range	V_{IN}	3 to 18	V
Output Voltage Range	V_o	1.1 to 6	V
Operating Temperature Range	T_{op}	-20 to +85	°C

■ Electrical Characteristics

(Ta=25°C unless otherwise specified)

Parameter	Symbol	Ratings			Unit	Conditions	
		min.	typ.	max.			
Dynamic Characteristics	Output Voltage	V_o	-1.2%	1.1	+1.2%	V	$V_{IN}=5V$, $V_{CC}=5V$, $VSNS$ connected to VO , $I_o=0A$
	Temperature Coefficient of Output Voltage	$\Delta V_o/\Delta T$		± 0.03		mV/°C	$V_{IN}=5V$, $V_{CC}=5V$, $VSNS$ connected to VO , $I_o=0A$, $T_a=0$ to $85^\circ C$
Circuit Current	Circuit Current (V_{CC} Terminal)	I_{op}			6	mA	$V_{CC}=5V$, $EN=H$, $FADJ=open$
	Circuit Current (V_{IN} Terminal)	I_{op}			1	mA	$V_{IN}=5V$, $EN=H$
	Standby Current 1 (V_{CC} Terminal)	I_{std1}			100	μA	$V_{CC}=5V$, $EN=L$
	Standby Current 2 (V_{IN} Terminal)	I_{std2}			50	μA	$V_{IN}=5V$, $EN=L$
Undervoltage Lockout	UVLO Operating Voltage 1 (V_{CC} Terminal)	V_{uvlo1}	3.7		4.45	V	$V_{IN}=5V$
	UVLO Operating Voltage 2 (V_{IN} Terminal)	V_{uvlo2}	2.5		2.9	V	$V_{CC}=5V$
On Time Control	On Time	T_{on}		1.27		μS	$V_{CC}=5V$, $V_{IN}=5V$, $V_o=2.5V$
	Minimum Off Time	T_{off}		0.7		μS	$V_{CC}=5V$
	REF Terminal Voltage	V_{ref}	1.1	1.2	1.3	V	$V_{CC}=5V$
	REF Terminal Source Current	I_{ref}			100	μA	$V_{CC}=5V$
High Side Drive	On Resistance (high side)	R_{onHH}		5.5		Ω	$V_H-V_{LIN}=5V$
	On Resistance (low side)	R_{onHL}		5.5		Ω	$V_H-V_{LIN}=5V$
Low Side Drive	On Resistance (high side)	R_{onLH}		5.5		Ω	$V_{CC}=5V$
	On Resistance (low side)	R_{onLL}		5.5		Ω	$V_{CC}=5V$
Bootstrap	Bootstrap Voltage	V_H-V_{LIN}	4.5	5	5.5	V	
Protection System	Current for Current Limit Detection	I_{lim}	90	100	110	μA	$V_{CC}=5V$, $V_{IN}=5V$
	Soft Start Terminal Current	I_{ss}		± 20		μA	$V_{CC}=5V$
	EN Low Level Voltage	V_{celo}	0		0.8	V	$V_{CC}=5V$
	EN High Level Voltage	V_{cehi}	2.4		V_{CC}	V	$V_{CC}=5V$
	EN Bias Level Current	ICE			5	μA	$V_{CC}=5V$, $EN=5V$
	PWRGD Good Voltage (high side)	V_{sens}		1.32		V	$V_{CC}=5V$
	PWRGD Good Voltage (low side)	V_{sens}		0.88		V	$V_{CC}=5V$
	PWRGD Low Output Voltage	V_{pwrgrd}			0.4	V	$V_{CC}=5V$, $I_{pwrgrd}=120\mu A$
	PWRGD Terminal Current	I_{pwrgrd}			120	μA	$V_{CC}=5V$, $V_{pwrgrd}=0.4V$
	PWRGD Leakage Current	I_{pwrgrd}			5	μA	$V_{pwrgrd}=5V$

Selection Guide

Linear Regulator ICs (low dropout voltage, built-in overcurrent protection and thermal shutdown circuits)

<Single Output>

Surface-Mount Type

Series Name	Output Current (A)	Output Voltage (V)				Variable (Reference Voltage) (V)				Dropout Voltage (V)	Maximum Input Voltage (V)	Package	Can Use Low ESR Capacitor	Page
		1.8	2.5	3.3	5.0	1.0	1.1	1.25	1.28					
SI-3000LU	0.25							⊙		0.5	18	SOT89-5	Yes	72
NR301E	1.0					⊙				0.6	30	eSOIC8	Yes	74
SI-3000LSA	1.0	⊙	⊙	⊙	⊙					1.2	16	SOP8	No	76
SI-3000KS	1.0		⊙	⊙					⊙	0.6	17	SOP8	Yes	78
SI-3000KD	1.0			⊙	⊙	⊙			⊙	0.6	35*1	TO263-5	Yes*2	80
SI-3000LLSL	1.5					⊙				0.3	10	SOP8	Yes	84
SI-3000ZD	3.0			⊙			⊙			0.6	10	TO263-5	No	86

*1: For the SI-3012KD and 3033KD: 17 V

*2: The SI-3010KD and 3050KD cannot use a low ESR capacitor.

Thru-Hole Type

Series Name	Output Current (A)	Variable (Reference Voltage) (V)		Dropout Voltage (V)	Maximum Input Voltage (V)	Package	Can Use Low ESR Capacitor	Page
		1.0	1.1					
SI-3000KF	1.0	⊙		0.5	35	TO220F-5	No	88
SI-3000ZF	3.0		⊙	0.7	10	TO220F-5	No	90

Application Note

Heat dissipation and Reliability

The reliability of an IC is highly dependent on its operating temperature. Please be sure to apply silicone grease to the IC and to mount it to the heatsink with a proper mounting torque.

Heatsink design should pay particular attention to ensuring sufficient heat dissipation capacity.

In addition, please take into account the air convection in operation.

Calculating Internal Power Dissipation(P_D)

P_D is given by the following formula:

$$P_D = I_O \cdot [V_{IN(\text{mean})} - V_O]$$

Determine the size of the heatsink according to the relationship between allowable power dissipation and ambient temperature.

Setting DC Input Voltage

The following is the waveform of a DC input voltage.

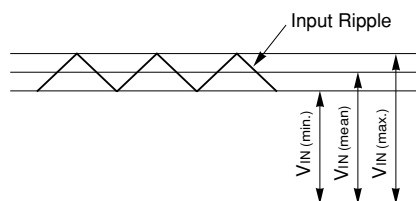

When setting the DC input voltage, please follow the instructions below:

- Make $V_{IN(\text{min})} \geq [(\text{Output voltage}) + (\text{Minimum dropout voltage})]$
- Make $V_{IN(\text{max})} \leq$ DC input voltage shown in the "Absolute Maximum Ratings"

Thermal Design

The maximum junction temperature $T_{J(\text{max})}$ given in the absolute maximum ratings is specific to each product type and must be strictly observed. Thus, thermal design must consider the maximum power dissipation $P_{D(\text{max})}$, which varies by the conditions of use, and the maximum ambient temperature $T_{a(\text{max})}$.

To simplify thermal design, T_a - P_D characteristic graphs are provided herein.

Please observe the following steps for heatsink design:

1. Obtain the maximum ambient temperature $T_{a(\text{max})}$.
2. Obtain the maximum power dissipation $P_{D(\text{max})}$.
3. Look for the intersection point on the T_a - P_D characteristic graph and determine the size of the heatsink.

Although the heatsink size is now obtained, in actual applications, 10-to-20% derating factor is generally introduced. Moreover, the heat dissipation capacity of a heatsink highly depends on how it is mounted. Thus, it is recommended to measure the heatsink and case temperature in the actual operating environment.

Please refer to the T_a - P_D characteristic graphs for respective product types.

Mounting Torque

SI-3000KF	} 0.588 to 0.686 [N•m] (6.0 to 7.0 [kgf•cm])
SI-3000ZF	

Recommended Silicone Grease

- Shin-Etsu Chemical Co., Ltd.: G746
- Momentive Performance Materials Inc.: YG-6260
- Dow Corning Toray Silicones Co., Ltd.: SC102

Please select proper silicone grease carefully since the oil in some grease products may penetrate the device and result in an extremely short device life.

Others

- Devices can not be operated in parallel connection aiming for a larger current.
- Diodes for isolation purpose are provided in between input and ground, and also in between output and ground. They may be broken down if the device is reverse biased. In this case, please clamp the device with low V_F diodes to protect them.

Rectifier Diodes for Power Supplies

To rectify the AC input voltage using rectifier diodes for power supplies, please use SANKEN rectifier diodes shown in the following list. (Please use a center-tap or bridge configuration in using stand-alone type diodes.)

Series Name	Diodes
SI-3000LU	SJPM-H4(Surface-Mount Stand-Alone Type, V_{RM} :400V, I_O :2.0A)
NR301E	
SI-3000LSA	
SI-3000KS	
SI-3000KD	
SI-3000LLSL	
SI-3000ZD	AM01Z(Axial Type, V_{RM} :200V, I_O :1.0A)
SI-3000KF	
SI-3000ZF	

SI-3000LU Series Surface-Mount, Low Current Consumption, Low Dropout Voltage

■ Features

- Compact surface-mount package (SOT89-5)
- Output current: 250 mA
- Low current consumption I_q (OFF) $\leq 1\mu\text{A}$ ($V_c = 0\text{V}$)
- Low dropout voltage: $V_{DIF} \leq 0.5\text{V}$ (at $I_o = 250\text{mA}$)
- Output voltage range (1.5V to 15V)
- Built-in drooping-type-overcurrent and thermal protection circuits

■ Absolute Maximum Ratings

(T_a=25°C)

Parameter	Symbol	Ratings	Unit
DC Input Voltage	V _{IN}	18	V
Output control terminal voltage	V _c	V _{IN}	V
DC Output Current	I _o	250	mA
Power Dissipation	P _D ^{*1}	0.75	W
Junction Temperature	T _J ^{*2}	-40 to +135	°C
Storage Temperature	T _{stg} ^{*2}	-40 to +125	°C
Thermal Resistance (Junction to Ambient Air)	θ_{ja} ^{*1}	146	°C/W

*1: When mounted on glass-epoxy board 40 × 40 mm (copper laminate area 2%).

*2: Thermal protection circuits may operate if the junction temperature exceeds 135°C.

■ Applications

- Auxiliary power supplies for PC
- Battery-driven electronic equipment

■ Recommended Operating Conditions

Parameter	Symbol	Ratings		Unit
		min.	max.	
Input Voltage	V _{IN}	*2, *3	V _O +2 ^{*1}	V
DC Output Current	I _o	0	250	mA
Operating Ambient Temperature	T _{op}	-20	85	°C

*1: V_{IN} (max) and I_o (max) are restricted by the relation P_D = (V_{IN} - V_O) × I_o.

Calculate these values referring to the reference data on next page.

*2: Refer to the Dropout Voltage parameter.

*3: For the SI-3012LU, set the input voltage to V_{IN} ≥ 2.4 V, and secure the minimum voltage as explained in "Setting DC Input Voltage" section in Linear Regulator Application Note.

■ Electrical Characteristics

(T_a=25°C, V_c=2V, unless otherwise specified)

Parameter	Symbol	Ratings			Unit	
		SI-3012LU(Variable)				
		min.	typ.	max.		
Reference Voltage	V _{ADJ} Conditions	1.210	1.250	1.290	V	
Dropout Voltage	V _{DIF} Conditions		V _{IN} =V _O +1V, I _o =10mA	0.3	V	
	Conditions		I _o =100mA(V _O =3.3V)	0.5		
	Conditions		I _o =250mA(V _O =3.3V)	0.5		
Line Regulation	ΔV_{LINE} Conditions		V _{IN} =V _O +1 to V _O +5V, I _o =10mA(V _O =3.3V)	10	mV	
Load Regulation	ΔV_{LOAD} Conditions		V _{IN} =V _O +1V, I _o =1 to 250mA(V _O =3.3V)	20	mV	
Temperature Coefficient of Reference Voltage	$\Delta V_o/\Delta T_a$ Conditions		±0.3 T _J =0 to 100°C		mV/°C	
Ripple Rejection	R _{REJ} Conditions		V _{IN} =V _O +1V, f=100 to 120Hz(V _O =3.3V)		dB	
Quiescent Circuit Current	I _q Conditions		V _{IN} =V _O +1V, I _o =0mA V _c =2V, R ₂ =100k Ω	150	μA	
Circuit Current at Output OFF	I _q (OFF) Conditions		V _{IN} =V _O +1V, V _c =0V	1	μA	
Overcurrent Protection Starting Current ^{*1}	I _{S1} Conditions	260	V _{IN} =V _O +1V		mA	
V _c Terminal	Control Voltage (Output ON) ^{*2}	V _c , IH	2.0		V	
	Control Voltage (Output OFF) ^{*2}	V _c , IL		0.8		
	Control Current (Output ON)	I _c , IH Conditions		V _c =2V	40	μA
	Control Current (Output OFF)	I _c , IL Conditions		0 V _c =0V	-5	μA

*1: I_{S1} is specified at the 5% drop point of output voltage V_O on the condition that V_{IN} = 3.3 V, and I_o = 10 mA.*2: Output is OFF when the output control terminal (V_c terminal) is open. Each input level is equivalent to LS-TTL level. Therefore, the device can be driven directly by LS-TTLs.

External Dimensions (SOT89-5)

(Unit : mm)



Pin Assignment

- ① ADJ
- ② GND
- ③ Vc
- ④ VIN
- ⑤ Vo

Plastic Mold Package Type
 Flammability: UL94V-0
 Product Mass: Approx. 0.05g

Block Diagram

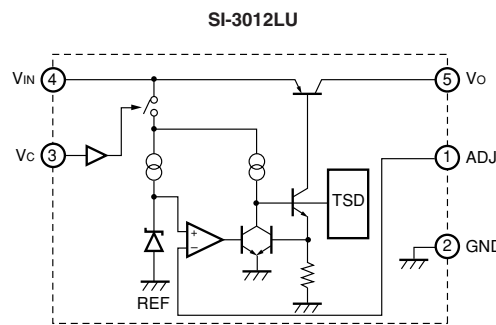

Typical Connection Diagram

SI-3012LU

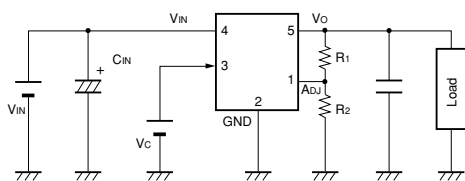

Co: Output capacitor (10 μ F or larger)

For SI-3000LU series, Co has to be a low ESR capacitor such as a ceramic capacitor.

CIN: Input capacitor (10 μ F approx.)

● Setting of SI-3012LU output voltage (recommended voltage: 1.5 V to 15 V)

R1 and R2: Resistors for output setting

The output voltage can be set by connecting R1 and R2 as shown in the diagram on the left.

R2: 100 k Ω is recommended

$$R1 = (Vo - V_{ADJ}) / (V_{ADJ} / R2)$$

Reference Data

Copper Laminate Area vs Power Dissipation
 Tj=100°C PCB size 40x40



• A monolithic ICs mounts an inner frame stage that is connected to the GND pin (pin 2). Therefore, enlarging the copper laminate area connected to the GND pin improves heat radiation effect.

• Obtaining the junction temperature
 Measure the temperature Tc at the lead part of the GND pin (pin 2) with a thermocouple, etc. Then, substitute this value in the following formula to obtain the junction temperature.

$$Tj = Pd \times \theta_j - c + Tc \quad (\theta_j - c = 5^\circ C/W)$$

NR301E Surface-Mount, Low Dropout Voltage

■ Features

- Adjustable Output voltage type
- Output current: 1 A
- $V_{DIF} (V_{IN} - V_{OUT}) \leq 0.6 \text{ V}$ (at $I_o = 1 \text{ A}$)
- Built-in protection circuits (OCP/TSD*)
 - * TSD has temperature hysteresis
- Built-in output ON/OFF function

■ Applications

- Secondary stabilized power supply (local power supply)

■ Absolute Maximum Ratings

(T_a=25°C)

Parameter	Symbol	Ratings	Unit
DC Input Voltage	V _{IN}	30	V
Output control terminal voltage	V _C	V _{IN}	V
ADJ terminal voltage	V _{ADJ}	5	V
Power Dissipation	P _D	1.4*	W
Junction to Ambient Air Thermal Resistance	θ_{j-a}	71	°C/W
Thermal Resistance (Junction to Lead (pin 4))	θ_{j-L}	26	°C/W
Junction Temperature	T _J	-30 to +125	°C
Storage Temperature	T _{stg}	-30 to +125	°C

*: When mounted on glass-epoxy board 30 × 30 mm (copper laminate area 25 × 25 mm).

■ Recommended Operating Conditions

Parameter	Symbol	Ratings		Unit
		min.	max.	
Input Voltage	V _{IN}	2.7	27*	V
DC Output Current	I _o	0	1*	A
Output Voltage Variable Range	V _{o(ADJ)}	1.1	16	V
Operating Ambient Temperature	T _{op(a)}	-30	85	°C
Operating Junction Temperature	T _{op(j)}	-20	100	°C

*: V_{IN} (max) and I_o (max) are restricted by the relation P_D = (V_{IN} - V_o) × I_o.

■ Electrical Characteristics

(T_a=25°C, V_C=2V, unless otherwise specified)

Parameter	Symbol	Ratings			Unit	Conditions
		NR301E				
		min.	typ.	max.		
Reference Voltage	V _{ADJ}	0.985	1	1.015	V	
Line Regulation	ΔV_{LINE}	–	25	50	mV	
Load Regulation	ΔV_{LOAD}	–	30	60	mV	
Dropout Voltage	ΔV_{DIF}	–	0.3	0.4	V	I _o =0.5A
		–	0.6	0.8	V	I _o =1.0A
Quiescent Circuit Current	I _q	0.5	0.9	1.6	mA	
Circuit Current at Output OFF	I _{q(off)}	–	0	1	μA	
Temperature Coefficient of Reference Voltage	$\Delta V_{ADJ}/\Delta T_a$	–	±0.1	–	mV/°C	
Ripple Rejection	R _{REJ}		55		dB	
Output Control	Output ON	V _{C(H)}	2	–	V	
Pin Voltage	Output OFF	V _{C(L)}	–	–	V	
	Output ON	I _{C(H)}	–	4	40	μA
Pin Current	Output ON	I _{C(L)}	–2	0	0.1	μA
	Output OFF	I _{S1}	1.1	–	–	A

*: I_{S1} is specified at the 5% drop point of output voltage V_o on the condition that V_{IN} = 3.3 V, and I_o = 10 mA.

External Dimensions (eSOIC8)

(Unit : mm)



External Dimensions

Symbol	Package A			Package B		
	MIN	TYP	MAX	MIN	TYP	MAX
A1	0	-	0.1524	0	0.1	0.15
A2	1.398	1.448	1.498	1.25	1.4	1.65
b	0.33	-	0.508	0.38	-	0.51
D	4.8	4.902	5.004	4.8	4.9	5
D1	3.053	3.18	3.307	3.1	3.3	3.5
E	5.893	-	6.918	5.8	6	6.2
E1	3.73	-	3.89	3.8	3.9	4
E2	2.033	2.16	2.287	2.2	2.4	2.6
e	-	1.27	-	-	1.27	-
L	0.508	-	0.762	0.45	0.6	0.8

Delivered in Package A or B.

Pin Assignment

- ① V_{OUT}
- ② ADJ
- ③ GND
- ④ NC
- ⑤ V_C
- ⑥ NC
- ⑦ NC
- ⑧ V_{IN}

Plastic Mold Package Type
 Flammability: UL94V-0
 Product Mass: Approx. 0.1g

Block Diagram

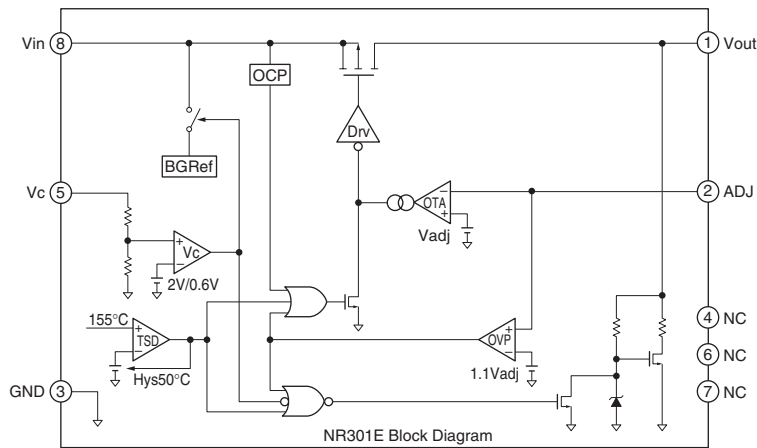

Typical Connection Diagram



C1: Input ceramic capacitor (Approx. 1μF)

Required when the input line contains inductance due to the wiring being long or for some other reason.

C2: Output oscillation prevention ceramic capacitor (Approx. 1μF)

D1: Reverse bias protection diode (This diode is required for protection against reverse biasing between the input and output.)

The output voltage can be set by connecting R1 and R2. Set R2 to 10kΩ (recommended), and calculate R1 from the following formula.

$$V_O = \frac{R1+R2}{R2} V_{ADJ}, \text{ therefore } R1 = \frac{V_O - V_{ADJ}}{V_{ADJ}} R2$$

SI-3000LSA Series Surface-Mount, Low Current Consumption, Low Dropout Voltage

Features

- Compact surface-mount package (SOP8)
- Output current: 1 A
- Low circuit current at output OFF:
 $I_{q(OFF)} \leq 1 \mu A$ ($V_C = 0 V$)
- Low dropout voltage: $V_{DIF} \leq 0.8 V$ (at $I_O = 1 A$)
 $V_{DIF} \leq 1.2 V$ ($I_O = 1 A$) for SI-3018LSA
- 4 types of output voltages (1.8 V, 2.5 V, 3.3 V, 5.0 V) available
- Output ON/OFF control terminal voltage compatible with LS-TTL
- Built-in foldback-type-overcurrent and thermal protection circuits

Absolute Maximum Ratings

($T_a = 25^\circ C$)

Parameter	Symbol	Rated	Unit
DC Input Voltage	V_{IN}	16	V
Output control terminal voltage	V_C	V_{IN}	V
DC Output Current	I_O	1	A
Power Dissipation	P_{D1}^{*1}	1.16	W
	P_{D2}^{*2}	1.1	W
Junction Temperature	T_J^{*3}	-30 to +150	$^\circ C$
Operating Ambient Temperature	T_{OP}	-30 to +150	$^\circ C$
Storage Temperature	T_{STG}	-30 to +150	$^\circ C$
Thermal Resistance (Junction to Lead (pin 8))	θ_{J-L}	36	$^\circ C/W$
Thermal Resistance (Junction to Ambient Air)	θ_{J-a}^{*2}	100	$^\circ C/W$

*1: When mounted on glass-epoxy board 56.5 × 56.5 mm (copper laminate area 100%).

*2: When mounted on glass-epoxy board 40 × 40 mm (copper laminate area 100%).

*3: Thermal protection circuits may be activated if the junction temperature exceeds 135 $^\circ C$.

Applications

- Auxiliary power supplies for PC
- Battery-driven electronic equipment

Recommended Operating Conditions

Parameter	Symbol	Ratings				Unit
		SI-3018LSA	SI-3025LSA	SI-3033LSA	SI-3050LSA	
DC Input Voltage Range	V_{IN}	3.1 to 3.5 ^{*1}	^{*2} to 3.5 ^{*1}	^{*2} to 5.2 ^{*1}	^{*2} to 8.0	V
DC Output Current Range	I_O	0 to 1				A
Operating Junction Temperature	T_{JP}	-20 to +125				$^\circ C$
Operating Ambient Temperature	T_{AP}	-30 to +85				$^\circ C$

*1: V_{IN} (max) and I_O (max) are restricted by the relation $P_D = (V_{IN} - V_O) \times I_O$.

Please calculate these values referring to the reference data on next page.

*2: Refer to the Dropout Voltage parameter.

Electrical Characteristics

($T_a = 25^\circ C$, $V_C = 2V$, unless otherwise specified)

Parameter	Symbol	Ratings												Unit
		SI-3018LSA			SI-3025LSA			SI-3033LSA			SI-3050LSA			
		min.	typ.	max.	min.	typ.	max.	min.	typ.	max.	min.	typ.	max.	
Output Voltage	V_O	1.764	1.800	1.836	2.450	2.500	2.550	3.234	3.300	3.366	4.90	5.00	5.10	V
	Conditions	$V_{IN} = 3.3V, I_O = 0.5A$			$V_{IN} = 3.3V, I_O = 0.5A$			$V_{IN} = 5V, I_O = 0.5A$			$V_{IN} = 6V, I_O = 0.5A$			
Dropout Voltage	V_{DIF}	-			0.4			0.4			0.4			V
	Conditions	-			$I_O \leq 0.5A$			$I_O \leq 0.5A$			$I_O \leq 0.5A$			
	Conditions	0.6	1.2				0.8			0.8			0.8	
Line Regulation	ΔV_{LINE}	2			2			3			3			mV
	Conditions	$V_{IN} = 3.1$ to 3.5V, $I_O = 0.3A$			$V_{IN} = 3.1$ to 3.5V, $I_O = 0.3A$			$V_{IN} = 4.5$ to 5.5V, $I_O = 0.3A$			$V_{IN} = 6$ to 7V, $I_O = 0.3A$			
Load Regulation	ΔV_{LOAD}	10			10			10			10			mV
	Conditions	$V_{IN} = 3.3V, I_O = 0$ to 1A			$V_{IN} = 3.3V, I_O = 0$ to 1A			$V_{IN} = 5V, I_O = 0$ to 1A			$V_{IN} = 6V, I_O = 0$ to 1A			
Temperature Coefficient of Output Voltage	$\Delta V_O / \Delta T_a$	± 0.3			± 0.3			± 0.3			± 0.5			mV/ $^\circ C$
	Conditions	$V_{IN} = 3.3V, I_O = 5mA, T_J = 0$ to 100 $^\circ C$			$V_{IN} = 3.3V, I_O = 5mA, T_J = 0$ to 100 $^\circ C$			$V_{IN} = 5V, I_O = 5mA, T_J = 0$ to 100 $^\circ C$			$V_{IN} = 6V, I_O = 5mA, T_J = 0$ to 100 $^\circ C$			
Ripple Rejection	R_{REJ}	60			57			55			55			dB
	Conditions	$V_{IN} = 3.3V, f = 100$ to 120Hz			$V_{IN} = 3.3V, f = 100$ to 120Hz			$V_{IN} = 5V, f = 100$ to 120Hz			$V_{IN} = 6V, f = 100$ to 120Hz			
Quiescent Circuit Current	I_q	1.7			1.7			1.7			1.7			mA
	Conditions	$V_{IN} = 3.3V, I_O = 0A$			$V_{IN} = 3.3V, I_O = 0A$			$V_{IN} = 5V, I_O = 0A$			$V_{IN} = 6V, I_O = 0A$			
Circuit Current at Output OFF	$I_{q(OFF)}$	1			1			1			1			μA
	Conditions	$V_{IN} = 3.3V, I_O = 0A, V_C = 0V$			$V_{IN} = 3.3V, I_O = 0A, V_C = 0V$			$V_{IN} = 5V, I_O = 0A, V_C = 0V$			$V_{IN} = 6V, I_O = 0A, V_C = 0V$			
Overcurrent Protection Starting Current ^{*1,3}	I_{S1}	1.2			1.2			1.2			1.2			A
	Conditions	$V_{IN} = 3.3V$			$V_{IN} = 3.3V$			$V_{IN} = 5V$			$V_{IN} = 6V$			
V_C Terminal	Control Voltage (Output ON) ^{*2}	V_C, IH	2.0		2.0		2.0		2.0		2.0		V	
	Control Voltage (Output OFF) ^{*2}	V_C, IL	0.8		0.8		0.8		0.8		0.8			
	Control Current (Output ON)	I_C, IH	40		40		40		40		40		μA	
	Conditions	$V_C = 2V$												
	Control Current (Output OFF)	I_C, IL	0		0		0		0		0		μA	
Conditions	$V_C = 0V$													

*1: I_{S1} is specified at the 5% drop point of output voltage V_O on the condition that $V_{IN} = 3.3 V$ (5 V for SI-3033LSA), and $I_O = 0.5 A$.

*2: Output is OFF when the output control terminal V_C is open. Each input level is equivalent to LS-TTL level. Therefore, the device can be driven directly by LS-TTLs.

*3: These products cannot be used in the following applications. Because these applications require a certain current at start-up and so the built-in foldback-type overcurrent protection may cause errors during start-up stage.

(1) Constant current load (2) Positive and negative power supply (3) Series-connected power supply (4) V_O adjustment by raising ground voltage

External Dimensions (SOP8)

(Unit : mm)

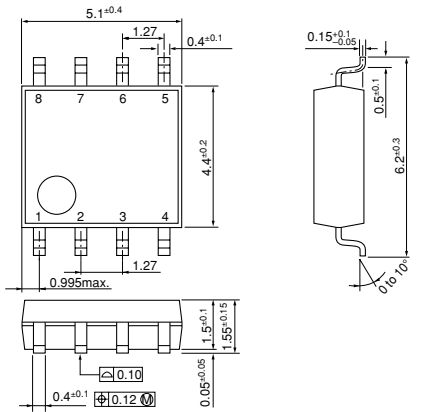

Pin Assignment

- ① VIN
- ② NC (Leave open)
- ③ VIN
- ④ Vc
- ⑤ GND
- ⑥ GND
- ⑦ Vo
- ⑧ Vo

Plastic Mold Package Type
 Flammability: UL94V-0
 Product Mass: Approx. 0.1g

Block Diagram

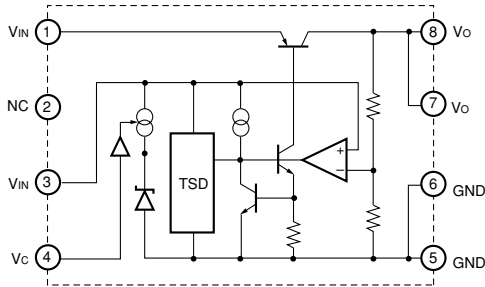

Typical Connection Diagram



Co: Output capacitor (22 μ F or larger)

CIN: Input capacitor (10 μ F)

This capacitor is required in the case of an inductive input line or long wiring.

Tantalum capacitors are recommended for CIN and Co, particularly at low temperatures.

* Leave pin 2 open.

Reference Data

PCB Copper Laminate Area vs. Junction to Ambient Air Thermal Resistance

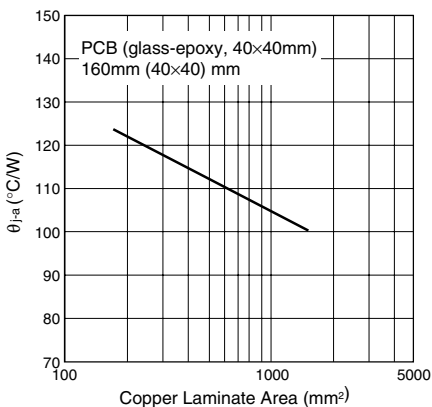

Allowable Output Current (vs. VIN-VOUT Voltage Difference) VIN-Io max

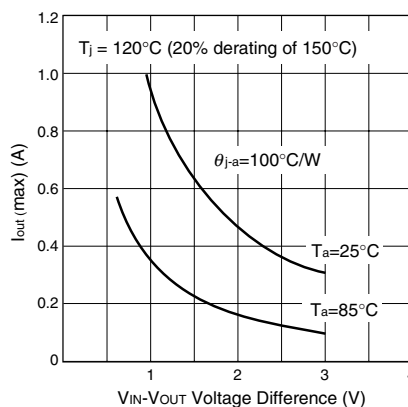

The inner frame stage, on which the PTR is mounted, is directly connected to the Vout pin.

Therefore, enlarging the copper laminate area around the Vout pin is really effective for a heat radiation.

SI-3000KS Series Surface-Mount, Low Current Consumption, Low Dropout Voltage

Features

- Compact surface-mount package (SOP8)
- Output current: 1.0 A
- Compatible with low ESR capacitor
- Low circuit current at output OFF $I_q \leq 350 \mu\text{A}$ ($I_o = 0 \text{ A}$, $V_c = 2 \text{ V}$)
- Low current consumption $I_q (\text{OFF}) \leq 1 \mu\text{A}$ ($V_c = 0 \text{ V}$)
- Low dropout voltage $V_{\text{DIF}} \leq 0.6 \text{ V}$ ($I_o = 1 \text{ A}$)
- 3 types of output voltages (2.5 V, 3.3 V, and variable type) available
- Output ON/OFF control terminal voltage compatible with LS-TTL
- Built-in drooping-type-overcurrent and thermal protection circuits

Absolute Maximum Ratings

($T_a=25^\circ\text{C}$)

Parameter	Symbol	Ratings	Unit
DC Input Voltage	V_{IN}^{*1}	17	V
Output Control Terminal Voltage	V_c	V_{IN}	V
DC Output Current	I_o^{*1}	1.0	A
Power Dissipation	$P_D^{*1, *2}$	0.76	W
Junction Temperature	T_j	-40 to +125	$^\circ\text{C}$
Storage Temperature	T_{stg}	-40 to +125	$^\circ\text{C}$
Thermal Resistance (Junction to Ambient Air)	θ_{j-a}	130	$^\circ\text{C/W}$
Thermal resistance (Junction to Lead (pin 7))	θ_{j-L}	22	$^\circ\text{C/W}$

*1: V_{IN} (max) and I_o (max) are restricted by the relation $P_D = (V_{\text{IN}} - V_o) \times I_o$. Please calculate these values referring to the Copper laminate area vs. Power dissipation data as shown hereinafter.

*2: When mounted on a glass epoxy board of 1600 mm² (copper laminate area 2%).

Applications

- Local power supplies
- Battery-driven electronic equipment

Electrical Characteristics

($T_a=25^\circ\text{C}$, $V_c=2 \text{ V}$, unless otherwise specified)

Parameter	Symbol	Ratings									Unit
		SI-3012KS (variable type)			SI-3025KS			SI-3033KS			
		min.	typ.	max.	min.	typ.	max.	min.	typ.	max.	
Input Voltage	V_{IN}	2.4			*1			*1			V
Output Voltage (Reference voltage V_{ADJ} for SI-3012KS)	$V_o (V_{\text{ADJ}})$	1.24	1.28	1.32	2.45	2.50	2.55	3.234	3.300	3.366	V
Dropout Voltage	V_{DIF}	$V_{\text{IN}}=3.3\text{V}$, $I_o=10\text{mA}$			$V_{\text{IN}}=3.3\text{V}$, $I_o=10\text{mA}$			$V_{\text{IN}}=5\text{V}$, $I_o=10\text{mA}$			V
	Conditions	$I_o=0.5\text{A}$ ($V_o=2.5\text{V}$)			$I_o=0.5\text{A}$			$I_o=0.5\text{A}$			
	Conditions	$I_o=1\text{A}$ ($V_o=2.5\text{V}$)			$I_o=1\text{A}$			$I_o=1\text{A}$			
Line Regulation	ΔV_{OLINE}			10			10			15	mV
	Conditions	$V_{\text{IN}}=3.3$ to 8V , $I_o=10\text{mA}$ ($V_o=2.5\text{V}$)			$V_{\text{IN}}=3.3$ to 8V , $I_o=10\text{mA}$			$V_{\text{IN}}=5$ to 10V , $I_o=10\text{mA}$			
Load Regulation	ΔV_{OLOAD}			40			40			50	mV
	Conditions	$V_{\text{IN}}=3.3\text{V}$, $I_o=0$ to 1A ($V_o=2.5\text{V}$)			$V_{\text{IN}}=3.3\text{V}$, $I_o=0$ to 1A			$V_{\text{IN}}=5\text{V}$, $I_o=0$ to 1A			
Quiescent Circuit Current	I_q			350			350			350	μA
	Conditions	$V_{\text{IN}}=3.3\text{V}$, $I_o=0\text{A}$, $V_c=2\text{V}$, $R_2=24\text{k}\Omega$			$V_{\text{IN}}=3.3\text{V}$, $I_o=0\text{A}$, $V_c=2\text{V}$			$V_{\text{IN}}=5\text{V}$, $I_o=0\text{A}$, $V_c=2\text{V}$			
Circuit Current at Output OFF	$I_q (\text{OFF})$			1			1			1	μA
	Conditions	$V_{\text{IN}}=3.3\text{V}$, $V_c=0\text{V}$			$V_{\text{IN}}=3.3\text{V}$, $V_c=0\text{V}$			$V_{\text{IN}}=5\text{V}$, $V_c=0\text{V}$			
Temperature Coefficient of Output Voltage	$\Delta V_o/\Delta T_a$		± 0.3			± 0.3			± 0.3		mV/ $^\circ\text{C}$
	Conditions	$T_j=0$ to 100°C ($V_o=2.5\text{V}$)			$T_j=0$ to 100°C			$T_j=0$ to 100°C			
Ripple Rejection	R_{REJ}		55			55			55		dB
	Conditions	$V_{\text{IN}}=3.3\text{V}$, $f=100$ to 120Hz ($V_o=2.5\text{V}$)			$V_{\text{IN}}=3.3\text{V}$, $f=100$ to 120Hz			$V_{\text{IN}}=5\text{V}$, $f=100$ to 120Hz			
Overcurrent Protection Starting Current ²	I_{S1}	1.2			1.2			1.2			A
	Conditions	$V_{\text{IN}}=3.3\text{V}$ ($V_o=2.5\text{V}$)			$V_{\text{IN}}=3.3\text{V}$			$V_{\text{IN}}=5\text{V}$			
V_c Terminal	Control Voltage (Output ON) ³	V_c, IH	2.0		2.0			2.0			V
	Control Voltage (Output OFF)	V_c, IL			0.8		0.8			0.8	
	Control Current (Output ON)	I_c, IH			40		40			40	μA
	Conditions	$V_c=2\text{V}$									
	Control Current (Output OFF)	I_c, IL	-5	0		-5	0		-5	0	
Conditions	$V_c=0\text{V}$										

*1: Refer to the Dropout Voltage parameter.

*2: The I_{S1} is specified at the 5% drop point of output voltage V_o on the condition that $V_{\text{IN}} = V_o + 1 \text{ V}$, and $I_o = 10 \text{ mA}$.

*3: Output is OFF when the output control terminal V_c is open. Each input level is equivalent to LS-TTL level. Therefore, the device can be driven directly by LS-TTLs.

External Dimensions (SOP8)

(Unit : mm)

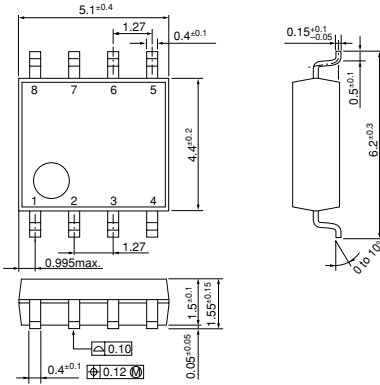

Pin Assignment

- ① V_c
- ② V_{IN}
- ③ V_O
- ④ Sense (ADJ for SI-3012KS)
- ⑤ GND
- ⑥ GND
- ⑦ GND
- ⑧ GND

Plastic Mold Package Type
 Flammability: UL 94V-0
 Product Mass: Approx. 0.1 g

Block Diagram

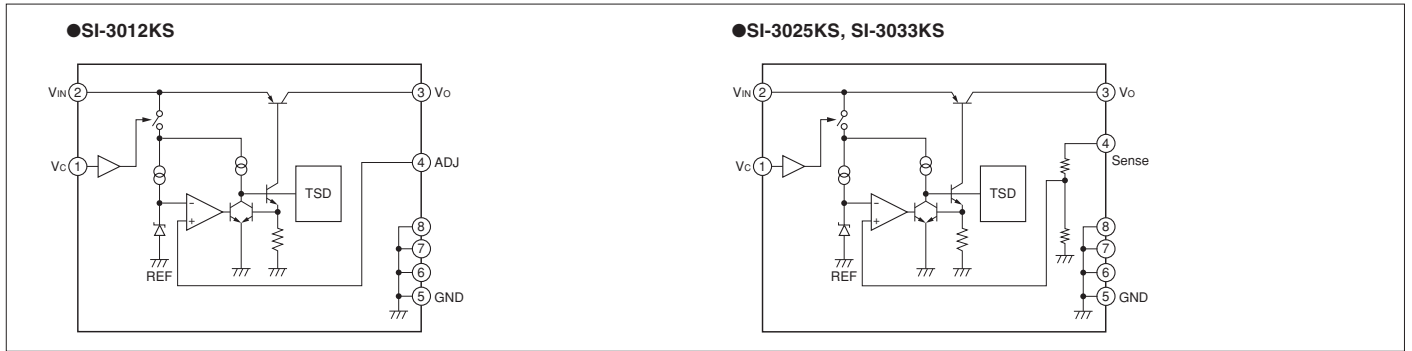

Typical Connection Diagram

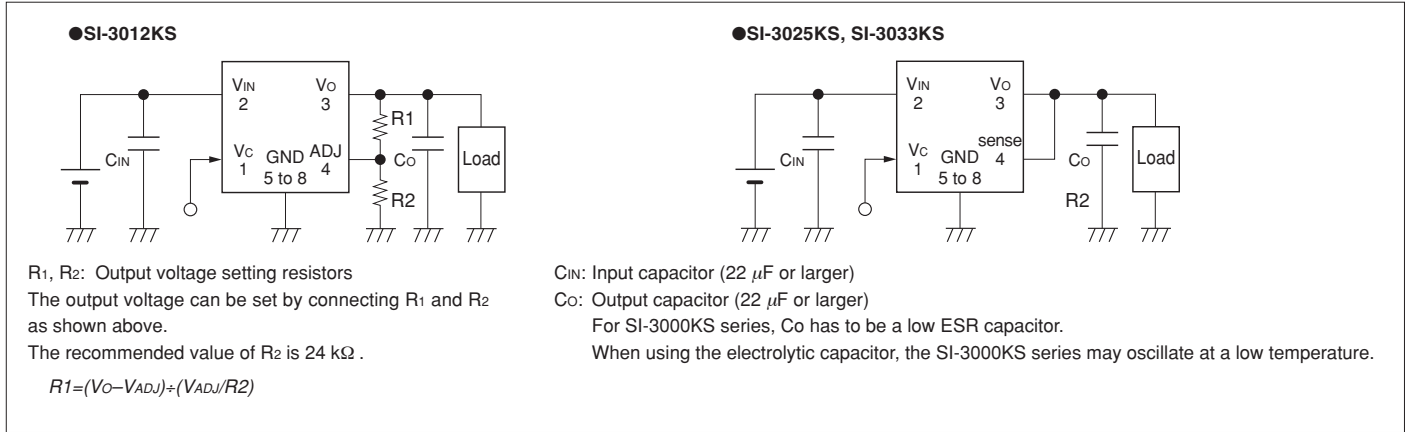

Reference Data

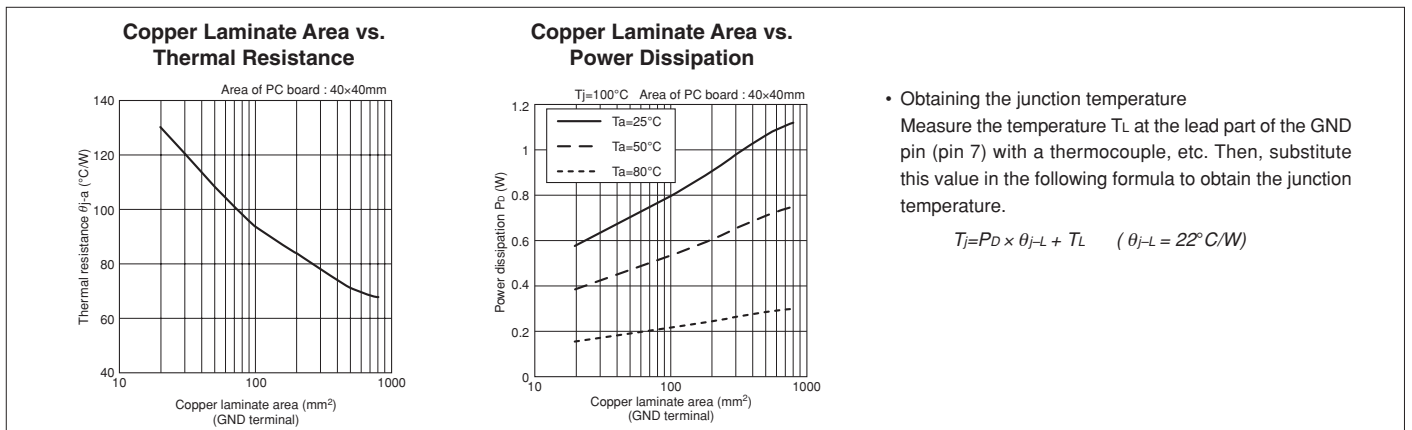

SI-3000KD Series Surface-Mount, Low Current Consumption, Low Dropout Voltage

Features

- Compact surface-mount package (TO263-5)
- Output current: 1.0A
- Low dropout voltage: $V_{DIF} \leq 0.6V$ (at $I_o = 1.0A$)
- Low circuit current consumption: $I_q \leq 350 \mu A$ (600 μA for SI-3010KD, SI-3050KD)
- Low circuit current at output OFF: $I_q (OFF) \leq 1 \mu A$
- Built-in overcurrent, thermal protection circuits
- Compatible with low ESR capacitors (SI-3012KD and SI-3033KD)

Absolute Maximum Ratings

($T_a=25^\circ C$)

Parameter	Symbol	Ratings		Unit
		SI-3012KD/3033KD	SI-3010KD/3050KD	
DC Input Voltage	V_{IN}	17	35 ^{*1}	V
Output Control Terminal Voltage	V_c	V_{IN}		V
DC Output Current	I_o	1.0		A
Power Dissipation	P_D^{*2}	3		W
Junction Temperature	T_j	-30 to +125		$^\circ C$
Storage Temperature	T_{stg}	-30 to +125		$^\circ C$
Thermal Resistance (Junction to Ambient Air)	θ_{j-a}	33.3		$^\circ C/W$
Thermal Resistance (Junction to Case)	θ_{j-c}	3		$^\circ C/W$

*1: A built-in input-overvoltage-protection circuit shuts down the output voltage at the Input Overvoltage Shutdown Voltage of the electrical characteristics.

*2: When mounted on glass-epoxy board of 1600mm² (copper laminate area 100%).

Applications

- Secondary stabilized power supply (local power supply)

Electrical Characteristics 1 (Low Input Voltage type compatible with low ESR output capacitor)

($T_a=25^\circ C, V_c=2V$, unless otherwise specified)

Parameter	Symbol	Ratings						Unit
		SI-3012KD (Variable type)			SI-3033KD			
		min.	typ.	max.	min.	typ.	max.	
Input Voltage	V_{IN}	2.4 ^{*3}		*4	*3		*4	V
Output Voltage (Reference Voltage for SI-3012KD)	$V_o (V_{ADJ})$	1.24	1.28	1.32	3.234	3.300	3.366	V
Line Regulation	ΔV_{OLINE}	$V_{IN}=3.3V, I_o=10mA$			$V_{IN}=5V, I_o=10mA$			mV
	Conditions	$V_{IN}=3.3 \text{ to } 8V, I_o=10mA (V_o=2.5V)$			$V_{IN}=5 \text{ to } 10V, I_o=10mA$			
Load Regulation	ΔV_{OLOAD}				40			mV
	Conditions	$V_{IN}=3.3V, I_o=0 \text{ to } 1A (V_o=2.5V)$			$V_{IN}=5V, I_o=0 \text{ to } 1A$			
Dropout Voltage	V_{DIF}	0.4			0.4			V
	Conditions	$I_o=0.5A (V_o=2.5V)$			$I_o=0.5A$			
	Conditions	$I_o=1A (V_o=2.5V)$			$I_o=1A$			
Quiescent Circuit Current	I_q	350			350			μA
	Conditions	$V_{IN}=3.3V, I_o=0A, V_c=2V, R_2=2.4k\Omega$			$V_{IN}=5V, I_o=0A, V_c=2V$			
Circuit Current at Output OFF	$I_q (OFF)$	1			1			μA
	Conditions	$V_{IN}=3.3V, V_c=0V$			$V_{IN}=5V, V_c=0V$			
Temperature Coefficient of Output Voltage	$\Delta V_o/\Delta T_a$	± 0.3			± 0.3			mV/ $^\circ C$
	Conditions	$T_j=0 \text{ to } 100^\circ C (V_o=2.5V)$			$T_j=0 \text{ to } 100^\circ C$			
Ripple Rejection	R_{REJ}	55			55			dB
	Conditions	$V_{IN}=3.3V, f=100 \text{ to } 120Hz, I_o=0.1A (V_o=2.5V)$			$V_{IN}=5V, f=100 \text{ to } 120Hz, I_o=0.1A$			
Overcurrent Protection Starting Current ^{*1}	I_{s1}	1.1			1.1			A
	Conditions	$V_{IN}=3.3V$			$V_{IN}=5V$			
V_c Terminal	Control Voltage (Output ON) ^{*2}	2			2			V
	Control Voltage (Output OFF)			0.8			0.8	
	Control Current (Output ON)			40			40	μA
	Conditions	$V_c=2V$			$V_c=2V$			
Control Current (Output OFF)	I_c, IL	-5	0		-5	0		μA
	Conditions	$V_c=0V$			$V_c=0V$			

*1: I_{s1} is specified at the 5% drop point of output voltage V_o under the condition of Output Voltage parameter.

*2: Output is OFF when the output control terminal (V_c terminal) is open. Each input level is equivalent to LS-TTL level. Therefore, the device can be driven directly by LS-TTLs.

*3: Refer to the Dropout Voltage parameter.

*4: $V_{IN} (max)$ and $I_o (max)$ are restricted by the relation $P_D = (V_{IN} - V_o) \times I_o$. Please calculate these values referring to the Copper laminate area vs. Power dissipation data.

■Electrical Characteristics 2 (High Input Voltage Type)

Parameter	Symbol	Ratings						Unit
		SI-3010KD (Variable type)			SI-3050KD			
		min.	typ.	max.	min.	typ.	max.	
Input Voltage	V_{IN}	2.4 ^{*1}		27 ^{*5}	^{*1}		15 ^{*5}	V
Output Voltage (Reference Voltage V_{ADJ} for SI-3010KD)	V_O (V_{ADJ})	0.98	1.00	1.02	4.90	5.00	5.10	V
	Conditions	$V_{IN}=7V, I_O=10mA$			$V_{IN}=7V, I_O=10mA$			
Line Regulation	ΔV_{OLINE}			30			30	mV
	Conditions	$V_{IN}=6$ to 11V, $I_O=10mA$ ($V_O=5V$)			$V_{IN}=6$ to 11V, $I_O=10mA$			
Load Regulation	ΔV_{OLOAD}			75			75	mV
	Conditions	$V_{IN}=7V,$ $I_O=0$ to 1A ($V_O=5V$)			$V_{IN}=7V, I_O=0$ to 1A			
Dropout Voltage	V_{DIF}			0.3			0.3	V
	Conditions	$I_O=0.5A$ ($V_O=5V$)			$I_O=0.5A$			
	Conditions	$I_O=1A$ ($V_O=5V$)			$I_O=1A$			
Quiescent Circuit Current	I_q			600			600	μA
	Conditions	$V_{IN}=7V, I_O=0A, V_C=2V$ $R_2=10k\Omega$			$V_{IN}=7V, I_O=0A,$ $V_C=2V$			
Circuit Current at Output OFF	I_q (OFF)			1			1	μA
	Conditions	$V_{IN}=7V, V_C=0V$			$V_{IN}=7V, V_C=0V$			
Temperature Coefficient of Output Voltage	$\Delta V_O/\Delta T_a$		± 0.5			± 0.5		mV/ $^{\circ}C$
	Conditions	$T_j=0$ to 100 $^{\circ}C$ ($V_O=5V$)			$T_j=0$ to 100 $^{\circ}C$			
Ripple Rejection	RREJ		75			75		dB
	Conditions	$V_{IN}=7V,$ $f=100$ to 120Hz, $I_O=0.1A$ ($V_O=5V$)			$V_{IN}=7V,$ $f=100$ to 120Hz, $I_O=0.1A$			
Overcurrent Protection Starting Current ^{*2}	I_{S1}	1.1			1.1			A
	Conditions	$V_{IN}=7V$			$V_{IN}=7V$			
Vc Terminal	Control Voltage (Output ON) ^{*3}	V_C, I_H	2.0		2.0			V
	Control Voltage (Output OFF) ^{*3}	V_C, I_L					0.8	
	Control Current (Output ON)	I_C, I_H			40			μA
	Control Current (Output OFF)	I_C, I_L	-5	0		-5	0	μA
		Conditions	$V_C=0V$			$V_C=0V$		
Input Overvoltage Shutdown Voltage	V_{OVP}	33			26			V
	Conditions	$I_O=10mA$			$I_O=10mA$			

*1: Refer to the Dropout Voltage parameter.

*2: I_{S1} is specified at the 5% drop point of output voltage V_O under the condition of Output Voltage parameter.

*3: Output is OFF when the output control terminal (Vc terminal) is open. Each input level is equivalent to LS-TTL level. Therefore, the device can be driven directly by LS-TTLs.

*4: SI-3010KD, SI-3050KD, cannot be used in the following applications because the built-in foldback-type overcurrent protection may cause errors during start-up stage.

(1) Constant current load (2) Positive and negative power supply (3) Series-connected power supply (4) V_O adjustment by raising ground voltage

*5: V_{IN} (max) and I_O (max) are restricted by the relation $P_D = (V_{IN} - V_O) \times I_O$. Please calculate these values referring to the Copper laminate area vs. Power dissipation data as shown hereinafter.

■External Dimensions (TO263-5)

(Unit : mm)

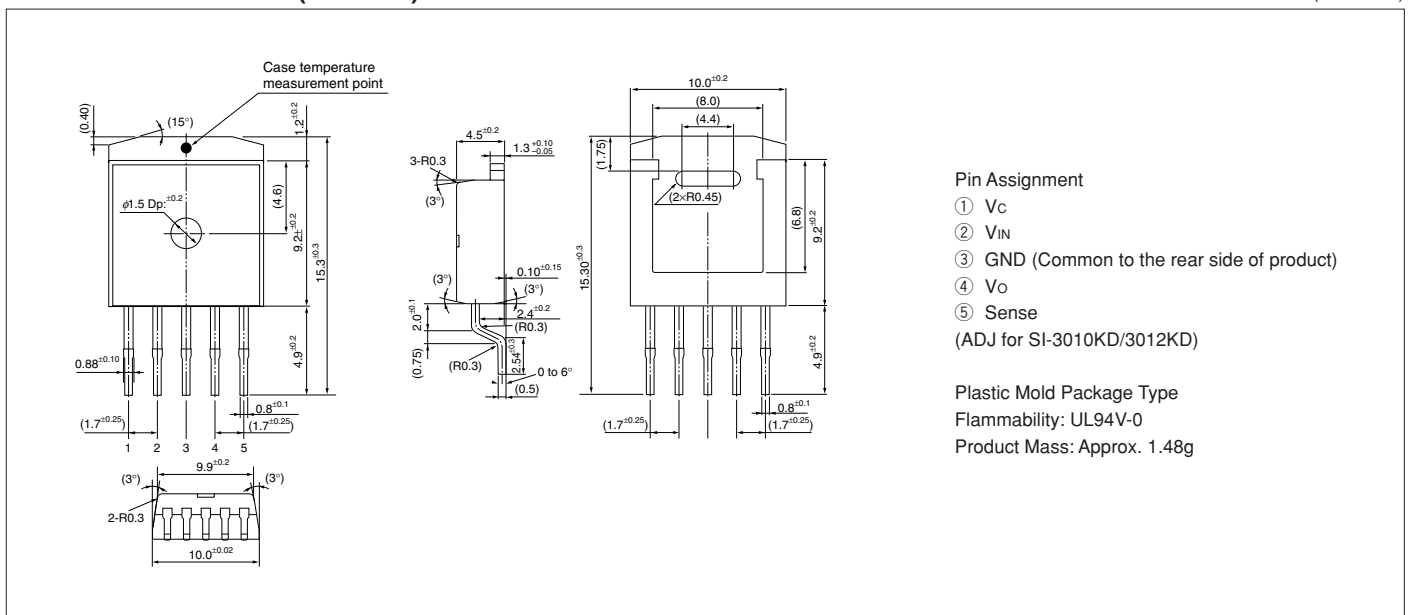

■Block Diagram



■Typical Connection Diagram

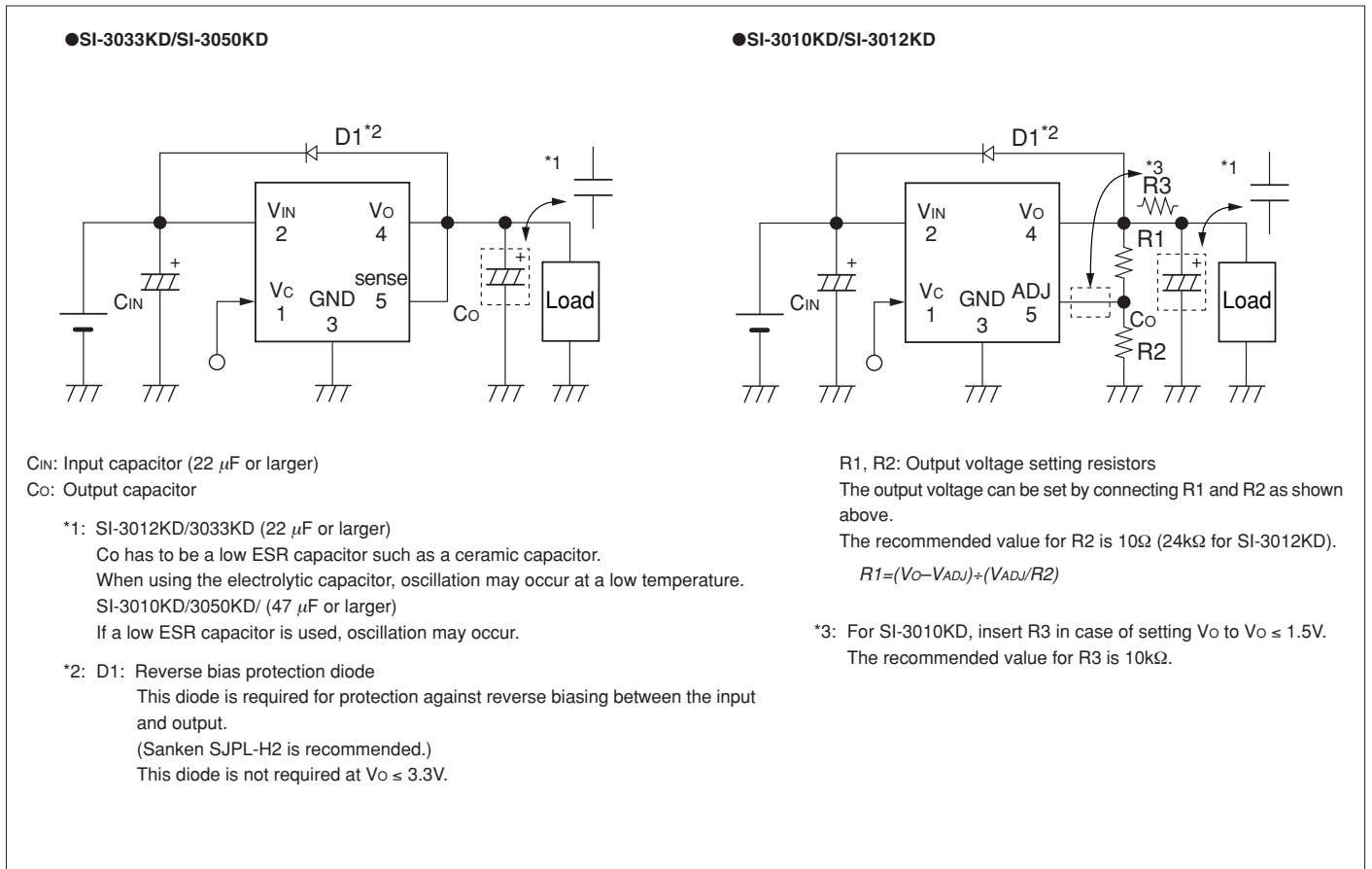

■Reference Data

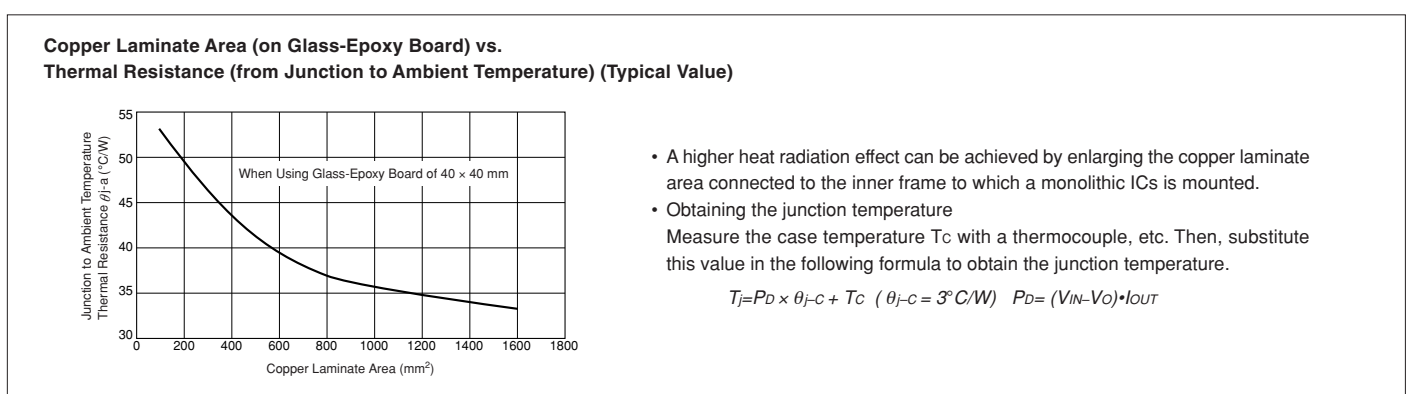

SI-3000LLSL Series Surface-Mount, Low Current Consumption, Low Dropout Voltage

■ Features

- Low input voltage (1.3V) and low output voltage (1.0V)
- Compact surface-mount package (SOP8)
- Low dropout voltage: $V_{DIF} \leq 0.3V$ (at $I_o = 1.5A$)
- Built-in overcurrent, input-overvoltage and thermal protection circuits
- Built-in ON/OFF function (OFF state circuit current: $1\mu A$ max.)
- Compatible with low ESR capacitors

■ Absolute Maximum Ratings

(T_a=25°C)

Parameter	Symbol	Ratings	Unit
DC Input Voltage	V _{IN}	10	V
DC Bias Voltage	V _B	10	V
Output Control Terminal Voltage	V _C	V _{IN}	V
DC Output Current	I _O	1.5	A
Power Dissipation	P _D ^{*1}	1.1	W
Junction Temperature	T _J	-30 to +125	°C
Operating Ambient Temperature	T _{OP}	-30 to +100	°C
Storage Temperature	T _{stg}	-30 to +125	°C
Thermal Resistance (Junction to Lead (Pin 8))	θ _(j-l)	36	°C/W
Thermal Resistance (Junction to Ambient Air)	θ _(j-a) ^{*1}	100	°C/W

*1: When mounted on glass-epoxy board of 40 × 40mm (copper laminate area 100%).

■ Applications

- On-board local power supply
- For stabilization of the secondary-side output voltage of switching power supplies

■ Recommended Operating Conditions

Parameter	Symbol	Ratings		Unit
		SI-3010LLSL		
Input Voltage	V _{IN}	1.4 to 3.6 ^{*1}		V
Bias Voltage	V _B	3.3 to 5.5		V
Output Current	I _O	0 to 1.5 ^{*1}		A
Operating Ambient Temperature	T _{OP}	-20 to +85 ^{*1}		°C

*1: V_{IN} (max) and I_O (max) are restricted by the relation P_D = (V_{IN} - V_O) × I_O.

■ Electrical Characteristics

(T_a=25°C, V_C=2V, V_{IN}=1.8V, V_B=3.3V, V_O=1.5V, unless otherwise specified)

Parameter	Symbol	Ratings			Unit	
		SI-3010LLSL				
		min.	typ.	max.		
Reference Voltage	V _{ADJ}	0.980	1.000	1.020	V	
	Conditions	I _O =10mA				
Line Regulation	ΔV _{OLINE}			10	mV	
	Conditions	V _{IN} =1.7 to 2.5V, I _O =10mA				
Load Regulation	ΔV _{OLOAD}			30	mV	
	Conditions	V _{IN} =1.8V, I _O =0 to 1.5A				
Dropout Voltage	V _{DIF}			0.3	V	
	Conditions	I _O =1.0A				
Quiescent Circuit Current	I _q		500	800	μA	
	Conditions	I _O =0A, R ₂ =10kΩ				
Circuit Current at Output OFF	I _q (OFF)			1	μA	
	Conditions	V _C =0V				
Temperature Coefficient of Output Voltage	ΔV _O /ΔT _a		±0.2		mV/°C	
	Conditions	T _J =0 to 100°C				
Overcurrent Protection Starting Current ^{*1}	I _{S1}	1.6			A	
	Conditions	V _{IN} =1.8V, V _B =3.3V				
V _C Terminal	Control Voltage (Output ON) ^{*2}	V _C , IH	2		V	
	Control Voltage (Output OFF)	V _C , IL		0.8	V	
	Control Current (Output ON)	I _C , IH			50	μA
	Control Current (Output ON)	Conditions	V _C =2.7V			
	Control Current (Output OFF)	I _C , IL			10	μA
	Control Current (Output OFF)	Conditions	V _C =0.4V			

*1: I_{S1} is specified at the 5% drop point of output voltage V_O on the condition that V_{IN} = overcurrent protection starting current, I_O = 10 mA.*2: Output is OFF when the output control terminal (V_C terminal) is open. Each input level is equivalent to LS-TTL level. Therefore, the device can be driven directly by LS-TTLs.

External Dimensions (SOP8)

(Unit : mm)



Pin Assignment

- ① Vo
- ② ADJ
- ③ Vb
- ④ Vc
- ⑤ GND
- ⑥ GND
- ⑦ Vin
- ⑧ Vin

Plastic Mold Package Type
 Flammability: UL94V-0
 Product Mass: Approx. 0.1g

Typical Connection Diagram/Block Diagram



C_{IN}, C_B: Input and bias capacitors (Approx. 0.1 to 10μF)

Required when the input line contains inductance or when the wiring is long.

C_O: Output capacitor (47μF or larger)

SI-3010LLSL is designed to use a low ESR capacitor (such as a ceramic capacitor) for the output capacitor. The recommended ESR value for an output capacitor is 500mΩ or less (at room temperature).

R1, R2: Output voltage setting resistors

The output voltage can be set by connecting R1 and R2 as shown at left.

The recommended value for R2 is 10kΩ.

$$R1 = (Vo - V_{ADJ}) / (V_{ADJ} / R2)$$

C_{SS}: Soft start capacitor

The rising time of the output voltage can be set by connecting C_{SS} between V_{OUT} and ADJ.

Reference Data

Copper Laminate Area - Power Dissipation

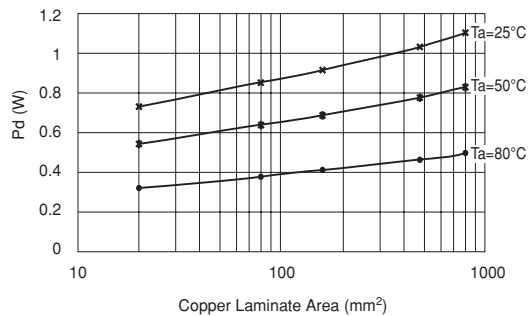

SI-3000ZD Series Surface-Mount, Low Dropout Voltage

■ Features

- Compact surface-mount package (TO263-5)
- Output current: 3.0A
- Low dropout voltage: $V_{DIF} \leq 0.6V$ (at $I_o = 3.0A$)
- Low circuit current at output OFF: $I_q (OFF) \leq 1\mu A$
- Built-in overcurrent and thermal protection circuits

■ Applications

- Secondary stabilized power supply (local power supply)

■ Absolute Maximum Ratings

($T_a=25^\circ C$)

Parameter	Symbol	Rated	Unit
DC Input Voltage	V_{IN}^{*1}	10	V
Output Control Terminal Voltage	V_c	6	V
DC Output Current	I_o^{*1}	3.0	A
Power Dissipation	P_D^{*3}	3	W
Junction Temperature	T_j	-30 to +125	$^\circ C$
Operating Ambient Temperature	T_{op}	-30 to +85	$^\circ C$
Storage Temperature	T_{stg}	-40 to +125	$^\circ C$
Thermal Resistance (Junction to Ambient Air)	θ_{ja}	33.3	$^\circ C/W$
Thermal Resistance (Junction to Case)	θ_{jc}	3	$^\circ C/W$

■ Recommended Operating Conditions

Parameter	Symbol	Rated	Unit	Remarks
Input Voltage	V_{IN}	*2 to 6^{*1}	V	
Output Current	I_o	0 to 3	A	
Operating Ambient Temperature	$T_{op(a)}$	-20 to +85	$^\circ C$	
Operating Junction Temperature	$T_{op(j)}$	-20 to +100	$^\circ C$	
Output Voltage Variable Range	V_{OAdj}	1.2 to 5	V	Only for SI-3011ZD. Refer to the block diagram.

*1: V_{IN} (max) and I_o (max) are restricted by the relation $P_D = (V_{IN} - V_o) \times I_o$.

*2: Set the input voltage to 2.4V or higher when setting the output voltage to 2.0V or lower (SI-3011ZD).

*3: When mounted on glass-epoxy board of 40 x 40mm (copper laminate area 100%).

■ Electrical Characteristics

($T_a=25^\circ C$, $V_c=2V$, unless otherwise specified)

Parameter	Symbol	Rated						Unit	
		SI-3011ZD (Variable type)			SI-3033ZD				
		min.	typ.	max.	min.	typ.	max.		
Output Voltage (Reference Voltage V_{ADJ} for SI-3011ZD)	$V_o (V_{ADJ})$	1.078	1.100	1.122	3.234	3.300	3.366	V	
	Conditions	$V_{IN}=V_o+1V, I_o=10mA$			$V_{IN}=5V, I_o=10mA$				
Line Regulation	ΔV_{OLINE}			10			10	mV	
	Conditions	$V_{IN}=3.3$ to $5V, I_o=10mA (V_o=2.5V)$			$V_{IN}=4.5$ to $5.5V, I_o=10mA$				
Load Regulation	ΔV_{LOAD}			40			40	mV	
	Conditions	$V_{IN}=3.3V, I_o=0$ to $3A (V_o=2.5V)$			$V_{IN}=5V, I_o=0$ to $3A$				
Dropout Voltage	V_{DIF}			0.6			0.6	V	
	Conditions	$I_o=3A (V_o=2.5V)$			$I_o=3A$				
Quiescent Circuit Current	I_q		1	1.5		1	1.5	mA	
	Conditions	$V_{IN}=V_o+1V, I_o=0A, V_c=2V$			$V_{IN}=5V, I_o=0A, V_c=2V$				
Circuit Current at Output OFF	$I_q (OFF)$			1			1	μA	
	Conditions	$V_{IN}=V_o+1V, V_c=0V$			$V_{IN}=5V, V_c=0V$				
Temperature Coefficient of Output Voltage	$\Delta V_o/\Delta T_a$		± 0.3			± 0.3		mV/ $^\circ C$	
	Conditions	$T_j=0$ to $100^\circ C$			$T_j=0$ to $100^\circ C$				
Ripple Rejection	R_{REJ}		60			60		dB	
	Conditions	$V_{IN}=V_o+1V, f=100$ to $120Hz, I_o=0.1A$			$V_{IN}=5V, f=100$ to $120Hz, I_o=0.1A$				
Overcurrent Protection Starting Current ^{*2}	I_{S1}	3.2			3.2			A	
	Conditions	$V_{IN}=V_o+1V$			$V_{IN}=5V$				
Vc Terminal	Control Voltage (Output ON) ^{*3}	V_c, IH	2		2			V	
	Control Voltage (Output OFF) ^{*3}	V_c, IL					0.8		
	Control Current (Output ON)	I_c, IH			100			100	μA
	Control Current (Output OFF)	I_c, IL	-5	0		-5	0		μA
	Conditions	$V_c=2.7V$			$V_c=2.7V$				
	Conditions	$V_c=0V$			$V_c=0V$				

*1: Set the input voltage to 2.4V or higher when setting the output voltage to 2.0V or lower.

*2: I_{S1} is specified at the -5% drop point of output voltage V_o under the condition of Output Voltage parameter.

*3: Output is OFF when the output control terminal (Vc terminal) is open. Each input level is equivalent to LS-TTL level. Therefore, the device can be driven directly by LS-TTLs.

*4: These products cannot be used for the following applications because the built-in foldback-type overcurrent protection may cause errors during start-up stage.

- (1) Constant current load (2) Positive and negative power supply (3) Series-connected power supply (4) V_o adjustment by raising ground voltage

External Dimensions (TO263-5)

(Unit : mm)

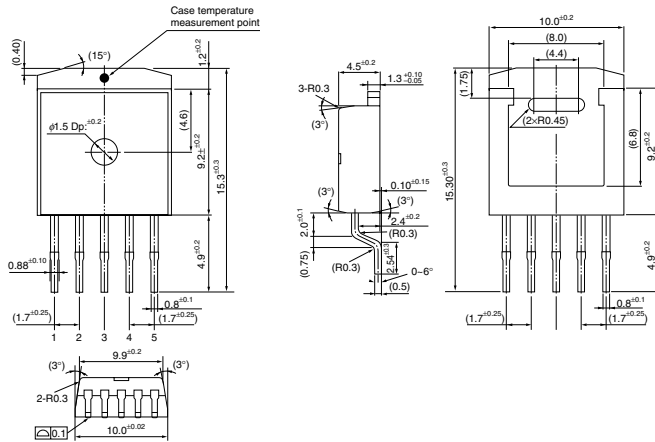

Pin Assignment

- ① Vc
 - ② VIN
 - ③ GND (Common to the rear side of product)
 - ④ VO
 - ⑤ Sense
- (ADJ for SI-3011ZD)

Plastic Mold Package Type
 Flammability: UL94V-0
 Product Mass: Approx. 1.48g

Block Diagram

SI-3011ZD



CIN: Input capacitor (Approx. 10μF)
 CO: Output capacitor (47μF or larger)
 The output voltage may oscillate if a low ESR type capacitor (such as a ceramic capacitor) is used for the output capacitor in the SI-3000ZD Series.

SI-3033ZD



R1, R2: Output voltage setting resistors
 The output voltage can be set by connecting R1 and R2 as shown at left.
 The recommended value for R2 is 10kΩ or 11kΩ.
 $R1 = (VO - V_{ADJ}) / (V_{ADJ} / R2)$
 *: Insert R3 in case of setting VO to VO ≤ 1.8V. The recommended value for R3 is 10kΩ.

Reference Data

Copper Laminate Area (on Glass-Epoxy Board) vs. Thermal Resistance (from Junction to Ambient Temperature) (Typical Value)



- A higher heat radiation effect can be achieved by enlarging the copper laminate area connected to the inner frame to which a monolithic IC is mounted.
- Obtaining the junction temperature
 Measure GND terminal temperature Tc with a thermocouple, etc. Then substitute this value in the following formula to obtain the junction temperature.

$$T_j = P_D \times \theta_{j-a} + T_c \quad P_D = (V_{IN} - V_O) \cdot I_{OUT}$$

SI-3000KF Series Low Current Consumption, Low Dropout Voltage

Features

- Compact full-mold package (equivalent to TO220)
- Output current: 1.0A
- Low dropout voltage: $V_{DIF} \leq 0.5V$ (at $I_o = 1.0A$)
- High ripple rejection: 75dB
- Low circuit current at output OFF: $I_q (OFF) \leq 1\mu A$
- Built-in overcurrent and thermal protection circuits

Applications

- Secondary stabilized power supply (local power supply)

Recommended Operating Conditions

Parameter	Symbol	Ratings		Unit
		SI-3010KF		
Input Voltage Range	V_{IN}	2.4 ² to 27 ¹		V
Output Current Range	I_o	0 to 1.0 ¹		A
Output Voltage Variable Range	$V_{O}ADJ$	1.1 to 16		V
Operating Ambient Temperature	T_{op}	-30 to +85		°C
Operating Junction Temperature	T_j	-20 to +100		°C

*1: $V_{IN} (max)$ and $I_o (max)$ are restricted by the relationship $P_D (max) = (V_{IN} - V_o) \times I_o = 16.6W$.

*2: Refer to the Dropout Voltage parameter.

Electrical Characteristics

Parameter	Symbol	Ratings			Unit	
		SI-3010KF				
		min.	typ.	max.		
Reference Voltage	V_{ADJ}	0.98	1.00	1.02	V	
	Conditions	$V_{IN}=7V, I_o=0.01A, V_C=2V, V_o=5A$				
Line Regulation	ΔV_{OLINE}			30	mV	
	Conditions	$V_{IN}=6$ to $15V, I_o=0.01A, V_C=2V, V_o=5A$				
Load Regulation	ΔV_{OLOAD}			75	mV	
	Conditions	$V_{IN}=7V, I_o=0$ to $1A, V_C=2V, V_o=5A$				
Dropout Voltage	V_{DIF}			0.3	V	
	Conditions	$I_o=0.5A, V_C=2V, V_o=5V$				
	Conditions	$I_o=1.0A, V_C=2V, V_o=5V$				
Quiescent Circuit Current	I_q			600	μA	
	Conditions	$V_{IN}=7V, I_o=0A, V_C=2V$				
Circuit Current at Output OFF	$I_q (OFF)$			1	μA	
	Conditions	$V_{IN}=7V, V_C=0V$				
Temperature Coefficient of Output Voltage	$\Delta V_o/\Delta T_a$		± 0.5		mV/°C	
	Conditions	$V_{IN}=7V, I_o=0.01A, V_C=2V, T_j=0$ to $100^\circ C, V_o=2.5V$				
Ripple Rejection	R_{REJ}		75		dB	
	Conditions	$V_{IN}=7V, I_o=0.1A, V_C=2V, f=100$ to $120Hz, V_o=5V$				
Overcurrent Protection Starting Current ³	I_{S1}	1.1			A	
	Conditions	$V_{IN}=7V, V_C=2V$				
V _C Terminal	Control Voltage (Output ON) ⁴	V_C, I_H	2		V	
		Conditions	$V_{IN}=7V$			
	Control Voltage (Output OFF)	V_C, I_L			0.8	V
		Conditions	$V_{IN}=7V$			
	Control Current (Output ON)	I_C, I_H			40	μA
		Conditions	$V_{IN}=7V, V_C=2V$			
Control Current (Output OFF)	I_C, I_L	-5	0		μA	
	Conditions	$V_{IN}=7V, V_C=0V$				
Input Overvoltage Shutdown Voltage	V_{OVP}	33			V	
	Conditions	$I_o=0.01A$				

*3: I_{S1} is specified at the 5% drop point of output voltage V_o on the condition that V_{IN} = overcurrent protection starting current, $I_o = 10$ mA.

*4: Output is OFF when the output control terminal V_C is open. Each input level is equivalent to LS-TTL level. Therefore, the device can be driven directly by LS-TTLs.

*5: SI-3000KFE cannot be used in the following applications because the built-in foldback-type overcurrent protection may cause errors during start-up stage.

(1) Constant current load (2) Positive and negative power supply (3) Series-connected power supply (4) V_o adjustment by raising ground voltage

Absolute Maximum Ratings

($T_a=25^\circ C$)

Parameter	Symbol	Ratings		Unit	Remarks
		SI-3010KF			
DC Input Voltage	V_{IN}	35 ¹		V	
Output Control Terminal Voltage	V_C	V_{IN}		V	
DC Output Current	I_o	1.0		A	
Power Dissipation	P_{D1}	16.6		W	With infinite heatsink
	P_{D2}	1.72		W	Without heatsink, stand-alone operation
Junction Temperature	T_j	-40 to +125		°C	
Storage Temperature	T_{stg}	-40 to +125		°C	
Operating Ambient Temperature	T_{op}	-40 to +100		°C	
Thermal Resistance (Junction to Case)	θ_{j-c}	6.0		°C/W	
Thermal Resistance (Junction to Ambient Air)	θ_{j-a}	58		°C/W	Without heatsink, stand-alone operation

*1: A built-in input-overvoltage-protection circuit shuts down the output voltage at the Input Overvoltage Shutdown Voltage of the electrical characteristics.

■Block Diagram



■Ta-Pd Characteristics



■Typical Connection Diagram

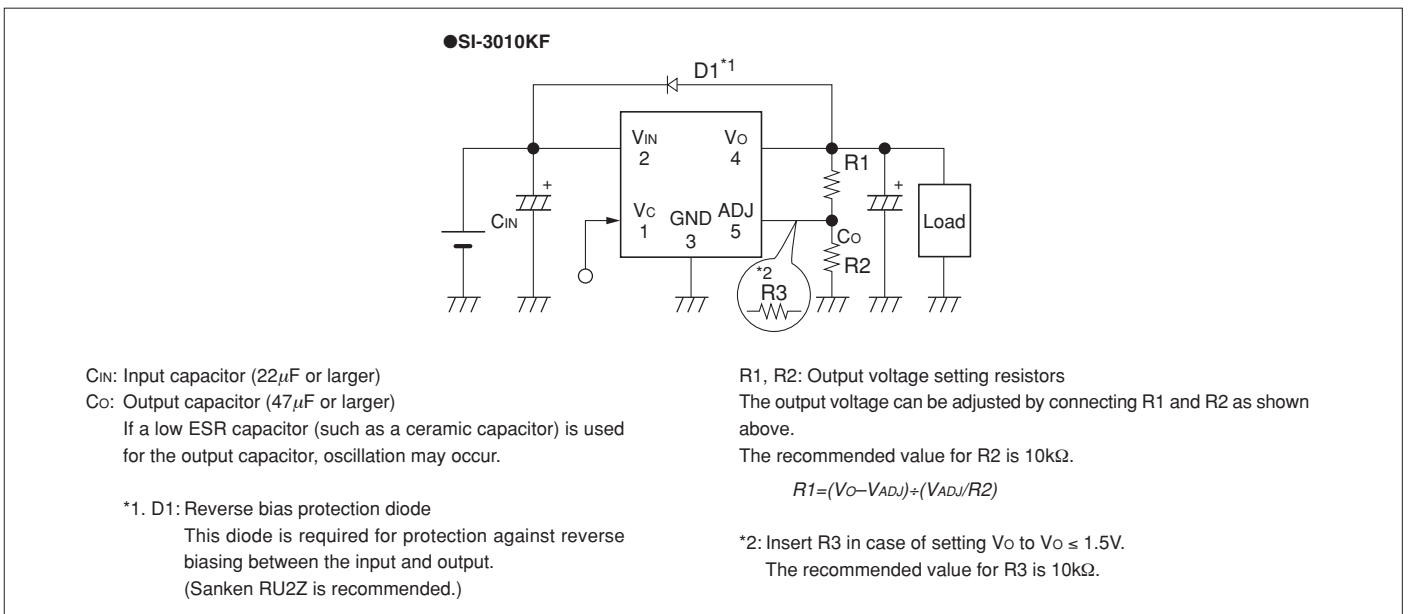

■External Dimensions (TO220F-5)

(Unit : mm)



SI-3000ZF Series 5-Terminal, Low Dropout Voltage

Features

- Compact full-mold package (equivalent to TO220)
- Output current: 3.0A
- Low dropout voltage: $V_{DIF} \leq 0.7V$ (at $I_o = 3.0A$)
- Low circuit current at output OFF: $I_q(OFF) \leq 1\mu A$
- Built-in overcurrent and thermal protection circuits

Applications

- Secondary stabilized power supply (local power supply)

Absolute Maximum Ratings

(T_a = 25°C)

Parameter	Symbol	Rated	Unit
DC Input Voltage	V _{IN} ¹	10	V
Output Control Terminal Voltage	V _C	6	V
DC Output Current	I _O ¹	3.0	A
Power Dissipation	P _{D1}	20 (With infinite heatsink)	W
		1.5 (Without heatsink, stand-alone operation)	W
Junction Temperature	T _J	-30 to +125	°C
Operating Ambient Temperature	T _{OP}	-30 to +100	°C
Storage Temperature	T _{STG}	-30 to +125	°C
Thermal Resistance (Junction to Case)	θ _{J-C}	5.0	°C/W
Thermal Resistance (Junction to Ambient Air)	θ _{J-A}	66.7 (Without heatsink, stand-alone operation)	°C/W

Recommended Operating Conditions

Parameter	Symbol	Rated	Unit
Input Voltage	V _{IN}	² to 6 ¹	V
Output Current	I _O	0 to 3	A
Operating Ambient Temperature	T _{OP (a)}	-20 to +85	°C
Operating Junction Temperature	T _{OP (j)}	-20 to +100	°C
Output Voltage Variable Range	V _{OADJ}	1.2 to 5	V

*1: V_{IN} (max) and I_O (max) are restricted by the relationship P_D = (V_{IN} - V_O) × I_O.

*2: Set the input voltage to 2.4V or higher when setting the output voltage to 2.0V or lower.

Electrical Characteristics

(T_a = 25°C, V_C = 2V, unless otherwise specified)

Parameter	Symbol	SI-3011ZF			Unit
		min.	typ.	max.	
Reference Voltage	V _{ADJ}	1.078	1.100	1.122	V
	Conditions	V _{IN} =V _O +1V, I _O =10mA			
Line Regulation	ΔV _{OLINE}			10	mV
	Conditions	V _{IN} =3.3 to 5V, I _O =10mA (V _O =2.5V)			
Load Regulation	ΔV _{OLOAD}			40	mV
	Conditions	V _{IN} =3.3V, I _O =0 to 3A (V _O =2.5V)			
Dropout Voltage	V _{DIF}			0.7	V
	Conditions	I _O =3A (V _O =2.5V)			
Quiescent Circuit Current	I _q		1	1.5	mA
	Conditions	V _{IN} =V _O +1V, I _O =0A, V _C =2V			
Circuit Current at Output OFF	I _q (OFF)			1	μA
	Conditions	V _{IN} =V _O +1V, V _C =0V			
Temperature Coefficient of Output Voltage	ΔV _O /ΔT _a		±0.3		mV/°C
	Conditions	T _J =0 to 100°C			
Ripple Rejection	R _{REJ}		60		dB
	Conditions	V _{IN} =V _O +1V, f=100 to 120Hz, I _O =0.1A			
Overcurrent Protection Starting Current ^{*2}	I _{S1}	3.2			A
	Conditions	V _{IN} =V _O +1V			
V _C Terminal	Control Voltage (Output ON) ^{*3}	2			V
	Control Voltage (Output OFF) ^{*3}			0.8	
	Control Current (Output ON)			100	μA
	Conditions	V _C =2.7V			
Control Current (Output OFF)		-5	0	μA	
Conditions	V _C =0V				

*1: Set the input voltage to 2.4V or higher when setting the output voltage to 2.0V or lower.

*2: I_{S1} is specified at the 5% drop point of output voltage V_O under the Output Voltage parameter conditions.

*3: Output is OFF when the output control terminal V_C is open. Each input level is equivalent to LS-TTL level. Therefore, the device can be driven directly by LS-TTLs.

*4: These products cannot be used in the following applications because the built-in foldback-type overcurrent protection may cause errors during start-up stage.

(1) Constant current load (2) Positive and negative power supply (3) Series-connected power supply (4) V_O adjustment by raising ground voltage

External Dimensions (TO220F-5)

(Unit : mm)



Typical Connection Diagram/Block Diagram



T_a-P_d Characteristics



1-2 Motor Driver ICs

Selection Guide

2-Phase Stepper Motor Unipolar Driver ICs

Excitation Method	Output Current (A)				Motor Supply Voltage (V)	Package	Remarks	Page
	1.0	1.5	2.0	3.0				
2-Phase Excitation	SLA7022MU	SLA7029M			to 46	ZIP15Pin with Fin		96
	SMA7022MU	SMA7029M			to 46	ZIP15Pin		
2-Phase/1-2 Phase Excitation	SLA7027MU	SLA7024M		SLA7026M	to 46	ZIP18Pin with Fin		98
	SLA7070MR	SLA7071MR	SLA7072MR	SLA7073MR	to 46	ZIP23Pin with Fin	Built-in sequencer, Current sensing resistors	100
	SLA7070MPR	SLA7071MPR	SLA7072MPR	SLA7073MPR	to 46	ZIP23Pin with Fin	Built-in sequencer, Current sensing resistors, Protection circuit	
	SLA7070MPRT	SLA7071MPRT	SLA7072MPRT	SLA7073MPRT	to 46	ZIP23Pin with Fin	Built-in sequencer, Current sensing resistors, Protection circuit, Thermal protection circuit	
	SLA7080MPR	SLA7081MPR	SLA7082MPR	SLA7083MPR	to 46	ZIP23Pin with Fin	Built-in Current sensing resistors, Protection circuit, Thermal protection circuit	102
2W 1-2 Phase Excitation μ Step Support	STA7130MPR	STA7131MPR	STA7132MPR		to 46	ZIP18Pin	Built-in sequencer, Current sensing resistors, Protection circuit, Thermal protection circuit	104
4W 1-2 Phase Excitation μ Step Support		SI-7321M			to 46	Surface-Mount 44Pin	Built-in sequencer, Protection circuit	106
	SLA7075MR	SLA7076MR	SLA7077MR	SLA7078MR	to 46	ZIP23Pin with Fin	Built-in sequencer, Current sensing resistors	108
	SLA7075MPR	SLA7076MPR	SLA7077MPR	SLA7078MPR	to 46	ZIP23Pin with Fin	Built-in sequencer, Current sensing resistors, Protection circuit	
	SLA7075MPRT	SLA7076MPRT	SLA7077MPRT	SLA7078MPRT	to 46	ZIP23Pin with Fin	Built-in sequencer, Current sensing resistors, Protection circuit, Thermal protection circuit	

5-Phase Stepper Motor Driver ICs

Excitation Method	Part Number	Power Supply Voltage(V)	Package	Remarks	Page
New Pentagon Drive	SI-7510	to 44	DIP30Pin	SLA5073+SLA5074 for Outputs	110

Brush DC Motor Driver ICs

Part Number	Output Current (A)		Power Supply Voltage (V)	Package	Remarks	Page
	Average	Maximum				
STA6940M	4.0	8.0(tw<100 μ S)	10 to 44	ZIP18Pin	Single Full Bridge	112

Low Voltage 3-Phase Brushless DC Motor Driver ICs

Part Number	Output Current (A)	Power Supply Voltage(V)	Package	Remarks	Page
SPI-6631M	3.0	13 to 33	HSOP16Pin	Pre-drive+Power	114
SI-6633M	4.0	10 to 38	QFN36	1-chip	116
SI-6633C	-	10 to 38	QFN36	Controller	118

High Voltage 3-Phase Brushless Motor Driver ICs

Part Number	Maximum Input Voltage	Output Current	Main Switch	RDS(on)/ VCE(sat)	Package	Package Type	Function*1										Main Application	Page	
							3.3V,5V	UVLO	OCP	OCL	TD	TSD	FO	3Shunt	Boot_Di	STP			Reg
SX68001MH	250V	2.0A	MOSFET	1.5Ω(max)	SOP_27Pin	Surface-mount	○	○	○	○	—	○	○	—	○	—	○	Fan motor	120
SX68002MH	500V	1.5A	MOSFET	4.0Ω(max)	SOP_27Pin	Surface-mount	○	○	○	○	—	○	○	—	○	—	○		
SX68003MH		2.5A	MOSFET	2.4Ω(max)	SOP_27Pin	Surface-mount	○	○	○	○	—	○	○	—	○	—	○		
SMA6821MH	250V	2.0A	MOSFET	1.5Ω(max)	SIP_24Pin	Full Mold	○	○	—	—	○	—	○	—	○	—	○	Fan motor	122
SMA6822MH	500V	1.5A	MOSFET	4.0Ω(max)	SIP_24Pin	Full Mold	○	○	—	—	○	—	○	—	○	—	○		
SMA6823MH		2.5A	MOSFET	2.4Ω(max)	SIP_24Pin	Full Mold	○	○	—	—	○	—	○	—	○	—	○		
SMA6862MZ	500V	1.5A	MOSFET	4.0Ω(max)	SIP_24Pin	Full Mold	—	○	○	○	—	○	○	—	○	—	—	Fan motor	124
SMA6863MZ		2.5A	MOSFET	1.7Ω(max)	SIP_24Pin	Full Mold	—	○	○	○	—	○	○	—	○	—	—		
SMA6865MZ		2.5A	MOSFET	2.4Ω(max)	SIP_24Pin	With Fin	—	○	○	○	—	○	○	—	○	—	—	Fan motor, pump	126
SLA6868MZ		3.0A	MOSFET	1.7Ω(max)	SIP_24Pin	With Fin	—	○	○	○	—	○	○	—	○	—	—		
SLA6870MZ		2.0A	MOSFET	4.0Ω(max)	DIP_40Pin	Full Mold	○	○	○	○	—	○	○	○	○	—	—	Fan motor	128
SIM6811M	2.5A	MOSFET	2.4Ω(max)	DIP_40Pin	Full Mold	○	○	○	○	—	○	○	○	○	—	—			
SIM6812M	500V	5A	IGBT	1.75V(typ)	DIP_40Pin	Full Mold	○	○	○	○	—	○	○	○	○	—	—	Fan motor, pump	130
SIM6822M		IGBT	1.75V(typ)	DIP_40Pin	Full Mold	○	○	○	○	—	○	○	○	○	○	—	—	Refrigerator compressor	
SIM6827M*2	600V	10A	IGBT	1.7V(typ)	DIP_33Pin	Full Mold	○	○	○	—	—	○	○	○	○	○	—	Air-conditioner compressor, Washing machine	130
SCM1241M		15A	IGBT	1.7V(typ)	DIP_33Pin	With Fin	○	○	○	—	—	○	○	○	○	○	—	Air-conditioner compressor, Washing machine	
SCM1243MF		20A	IGBT	1.7V(typ)	DIP_33Pin	With Fin	○	○	○	—	—	○	○	○	○	○	—	Air-conditioner compressor	
SCM1245MF		30A	IGBT	1.7V(typ)	DIP_33Pin	With Fin	○	○	○	—	—	○	○	○	○	○	—	Air-conditioner compressor	
SCM1246MF		500V	5A	MOSFET	0.8Ω(max)	DIP_33Pin	Full Mold	○	○	○	—	—	○	○	○	○	○	—	

*1: 3.3V,5V 3.3 V and 5 V input levels are supported

UVLO Under voltage lockout protection

OCP Over current protection

OCL Overcurrent limiting

TD Thermal detection

TSD Thermal shutdown

FO Fault output

3shunt 3 shunt support

Boot_Di Built-in bootstrap diode

STP Shoot through prevention

Reg Built-in regulator output

*2: SIM6827M is the low noise version of SIM6822M.

Application Note

■ Setup Precautions

- Recommended mounting torque
0.588 to 0.784 [N•m](6.0 to 8.0 [kgf•cm])
- Recommended silicone grease
Shin-Etsu Chemical Co., Ltd.: G746
Momentive Performance Materials Inc.: YG-6260
Dow Corning Toray Silicone Co., Ltd.: SC102
Please select proper silicone grease carefully since the oil in some grease products may penetrate the device and result in an extremely short device life.

■ Handling Precautions

When using the following products that use C-MOS circuits for input terminals, observe the following.

SLA707xMR, MPR, MPRT

SLA708xMPR

SLA6800M Series

SMA6800M Series

STA713xM

STA6940M

SPI-6631M

SCM1200M Series

SX68000M Series

SI-66xx Series

SIM6800M Series

- Carefully control the humidity of the room to prevent the buildup of static electricity. Since static electricity is particularly a problem during the winter, be sure to take sufficient precautions.

Take care to make sure that static electricity is not applied to the IC during wiring and assembly. Take precautions such as shorting the terminals of the printed circuit board to ensure that they are at the same electrical potential.

SLA7022MU/SLA7029M/SMA7022MU/SMA7029M 2-Phase Excitation

Absolute Maximum Ratings

(T_a=25°C)

Parameter	Symbol	Ratings				Unit
		SLA7022MU	SLA7029M	SMA7022MU	SMA7029M	
Motor Supply Voltage	V _{CC}	46				V
FET Drain-Source Voltage	V _{DSS}	100				V
Control Supply Voltage	V _S	46				V
TTL Input Voltage	V _{IN}	7				V
Reference Voltage	V _{REF}	2				V
Output Current	I _O	1	1.5	1	1.5	A
Power Dissipation	P _{D1}	4.5 (Without Heatsink)		4.0 (Without Heatsink)		W
	P _{D2}	35 (T _C =25°C)				28 (T _C =25°C)
Channel Temperature	T _{ch}	+150				°C
Storage Temperature	T _{stg}	-40 to +150				°C

Electrical Characteristics

(T_a=25°C)

Parameter	Symbol	Ratings												Unit
		SLA7022MU			SLA7029M			SMA7022MU			SMA7029M			
		min.	typ.	max.	min.	typ.	max.	min.	typ.	max.	min.	typ.	max.	
Control Supply Current	I _S	10			15			10			15			mA
	Condition	V _S =44V			V _S =44V			V _S =44V			V _S =44V			
Control Supply Voltage	V _S	10	24	44	10	24	44	10	24	44	10	24	44	V
FET Drain-Source Voltage	V _{DSS}	100			100			100			100			V
FET ON Voltage	V _{DS}	0.85			0.6			0.85			0.6			V
	Condition	I _D =1A, V _S =14V			I _D =1A, V _S =14V			I _D =1A, V _S =14V			I _D =1A, V _S =14V			
FET Drain Leakage Current	I _{DSS}	4			4			4			4			mA
Condition	V _{DSS} =100V, V _S =44V			V _{DSS} =100V, V _S =44V			V _{DSS} =100V, V _S =44V			V _{DSS} =100V, V _S =44V				
FET Diode Forward Voltage	V _{SD}	1.2			1.1			1.2			1.1			V
Condition	I _D =1A			I _D =1A			I _D =1A			I _D =1A				
TTL Input Current	I _{IH}	40			40			40			40			μA
	Condition	V _{IH} =2.4V, V _S =44V			V _{IH} =2.4V, V _S =44V			V _{IH} =2.4V, V _S =44V			V _{IH} =2.4V, V _S =44V			
	I _{IL}	-0.8			-0.8			-0.8			-0.8			mA
Condition	V _{IL} =0.4V, V _S =44V			V _{IL} =0.4V, V _S =44V			V _{IL} =0.4V, V _S =44V			V _{IL} =0.4V, V _S =44V				
TTL Input Voltage (Active High)	V _{IH}	2			2			2			2			V
	Condition	I _D =1A			I _D =1A			I _D =1A			I _D =1A			
	V _{IL}	0.8			0.8			0.8			0.8			
TTL Input Voltage (Active Low)	V _{IH}	2			2			2			2			V
	Condition	V _{DSS} =100V			V _{DSS} =100V			V _{DSS} =100V			V _{DSS} =100V			
	V _{IL}	0.8			0.8			0.8			0.8			
Switching Time	T _r	0.5			0.5			0.5			0.5			μs
	Condition	V _S =24V, I _D =0.8A			V _S =24V, I _D =1A			V _S =24V, I _D =0.8A			V _S =24V, I _D =1A			
	T _{stg}	0.7			0.7			0.7			0.7			
	Condition	V _S =24V, I _D =0.8A			V _S =24V, I _D =1A			V _S =24V, I _D =0.8A			V _S =24V, I _D =1A			
	T _f	0.1			0.1			0.1			0.1			
	Condition	V _S =24V, I _D =0.8A			V _S =24V, I _D =1A			V _S =24V, I _D =0.8A			V _S =24V, I _D =1A			

Internal Block Diagram



Typical Connection Diagram (Recommended component values)



External Dimensions (ZIP15 with Fin [SLA15Pin] /ZIP15[SMA15Pin])

(Unit:mm)



SLA7027MU/SLA7024M/SLA7026M 2-Phase/1-2 Phase Excitation

Absolute Maximum Ratings

(T_a=25°C)

Parameter	Symbol	Ratings			Unit
		SLA7027MU	SLA7024M	SLA7026M	
Motor Supply Voltage	V _{CC}	46			V
FET Drain-Source Voltage	V _{DSS}	100			V
Control Supply Voltage	V _S	46			V
Input Voltage	V _{IN}	7			V
Reference Voltage	V _{REF}	2			V
Output Current	I _O	1	1.5	3	A
Power Dissipation	P _{D1}	4.5 (Without Heatsink)			W
	P _{D2}	35 (T _C =25°C)			W
Channel Temperature	T _{ch}	+150			°C
Storage Temperature	T _{stg}	-40 to +150			°C

Electrical Characteristics

Parameter	Symbol	Ratings									Unit
		SLA7027MU			SLA7024M			SLA7026M			
		min.	typ.	max.	min.	typ.	max.	min.	typ.	max.	
Control Supply Current	I _S	10			10			15			mA
	Condition	V _S =44V			V _S =44V			V _S =44V			
Control Supply Voltage	V _S	10	24	44	10	24	44	10	24	44	V
FET Drain-Source Voltage	V _{DSS}	100			100			100			V
	Condition	V _S =44V, I _{DSS} =250μA			V _S =44V, I _{DSS} =250μA			V _S =44V, I _{DSS} =250μA			
FET ON Voltage	V _{DS}	0.85			0.6			0.85			V
	Condition	I _D =1A, V _S =14V			I _D =1A, V _S =14V			I _D =3A, V _S =14V			
FET Drain Leakage Current	I _{DSS}	4			4			4			mA
	Condition	V _{DSS} =100V, V _S =44V			V _{DSS} =100V, V _S =44V			V _{DSS} =100V, V _S =44V			
FET Diode Forward Voltage	V _{SD}	1.2			1.1			2.3			V
	Condition	I _D =1A			I _D =1A			I _D =3A			
TTL Input Current	I _{IH}	40			40			40			μA
	Condition	V _{IH} =2.4V, V _S =44V			V _{IH} =2.4V, V _S =44V			V _{IH} =2.4V, V _S =44V			
	I _{IL}	-0.8			-0.8			-0.8			mA
Condition	V _{IL} =0.4V, V _S =44V			V _{IL} =0.4V, V _S =44V			V _{IL} =0.4V, V _S =44V				
TTL Input Voltage (Active High)	V _{IH}	2			2			2			V
	Condition	I _D =1A			I _D =1A			I _D =3A			
	V _{IL}	0.8			0.8			0.8			
TTL Input Voltage (Active Low)	V _{IH}	2			2			2			V
	Condition	V _{DSS} =100V			V _{DSS} =100V			V _{DSS} =100V			
	V _{IL}	0.8			0.8			0.8			
Switching Time	T _r	0.5			0.5			0.5			μs
	Condition	V _S =24V, I _D =0.8A			V _S =24V, I _D =1A			V _S =24V, I _D =1A			
	T _{sig}	0.7			0.7			0.7			
	Condition	V _S =24V, I _D =0.8A			V _S =24V, I _D =1A			V _S =24V, I _D =1A			
	T _f	0.1			0.1			0.1			
Condition	V _S =24V, I _D =0.8A			V _S =24V, I _D =1A			V _S =24V, I _D =1A				

Internal Block Diagram



Typical Connection Diagram (Recommended component values)

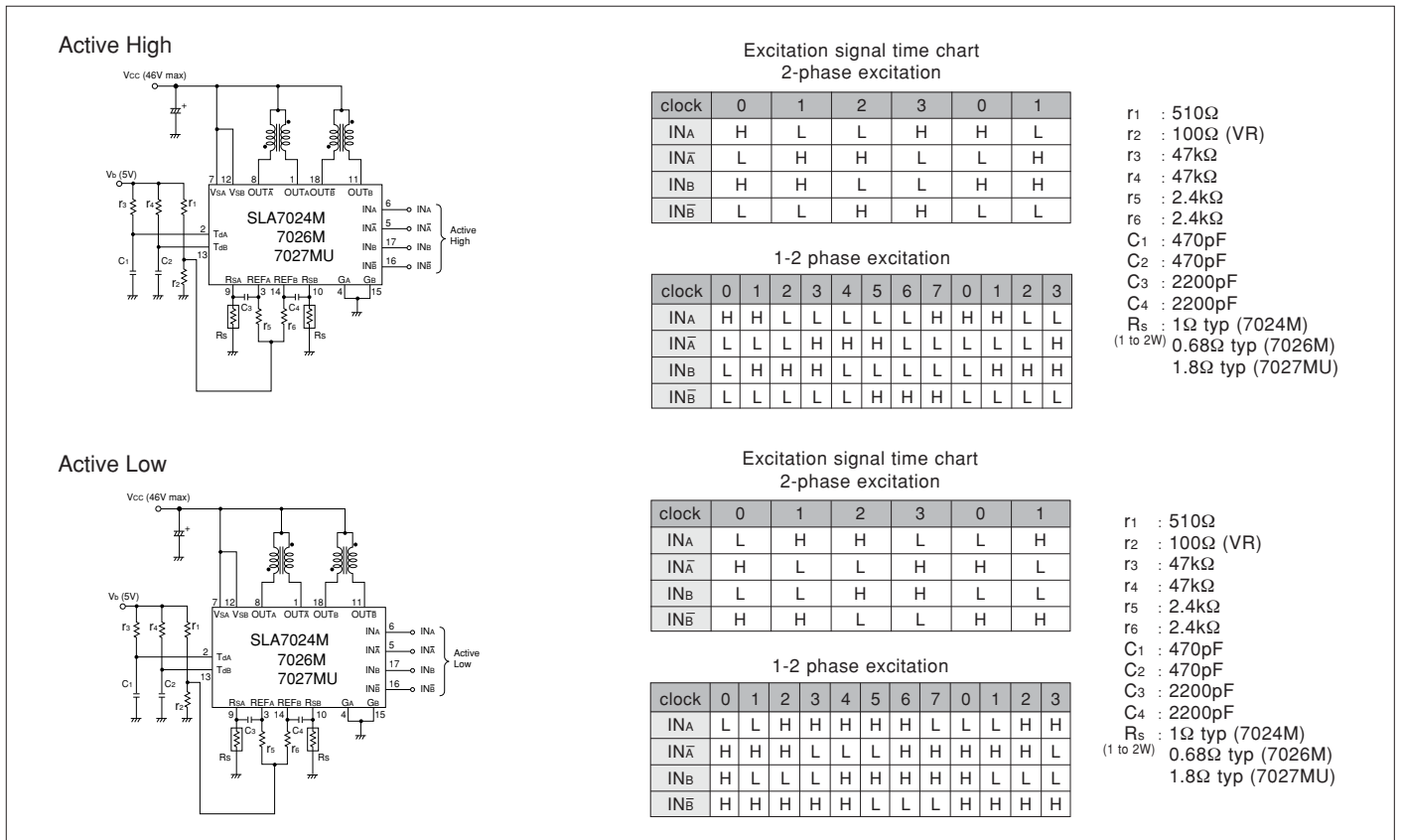

External Dimensions (ZIP18 with Fin [SLA18Pin])

(Unit : mm)



SLA7070MR, MPR, MPRT/7071MR, MPR, MPRT/7072MR, MPR, MPRT/7073MR, MPR, MPRT 2-Phase/1-2 Phase Excitation Support, Built-in Sequencer

☆ For new designs, use SLA707xMPRT.

■Features

- Lineup of built-in current sense resistor and built-in protection circuit-type
- Power supply voltages, V_{BB} : 46 V (max), 10 to 44 V normal operating range
- Logic supply voltages, V_{DD} : 3.0 to 5.5 V
- Maximum output currents: 1 A, 1.5 A, 2 A, and 3 A
- Built-in sequencer
- Self-excitation PWM current control with fixed off-time
- Synchronous PWM chopping function prevents motor noise in Hold mode
- Sleep mode for reducing the IC input current in stand-by state
- ZIP type 23-pin molded package (SLA package)

■Absolute Maximum Ratings

Parameter	Symbol	Ratings	Unit	Remarks
Motor Supply Voltage	V_M	46	V	
Driver Supply Voltage	V_{BB}	46	V	
Logic Supply Voltage	V_{DD}	6	V	
Output Current	I_O	*1	A	Mode F
Logic Input Voltage	V_{IN}	-0.3 to $V_{DD}+0.3$	V	
REF Input Voltage	V_{REF}	-0.3 to $V_{DD}+0.3$	V	
Sense Voltage	V_{RS}	± 2	V	Excluding $t_w < 1\mu s$
Power Dissipation	PD	4.7	W	When $T_a = 25^\circ C$
		17		When $T_c = 25^\circ C$
Junction Temperature	T_j	+150	$^\circ C$	
Operating Ambient Temperature	T_a	-20 to +85	$^\circ C$	
Storage Temperature	T_{stg}	-30 to +150	$^\circ C$	

*1: Output current value may be limited for the SLA7070MR, MPR, MPRT (1.0 A), SLA7071MR, MPR, MPRT (1.5 A), SLA7072MR, MPR, MPRT (2.0 A), and SA7073MR, MPR, MPRT (3.0 A), depending on the duty ratio, ambient temperature, and heating conditions.

Be sure that junction temperature of T_j is not exceeded under any circumstances.

■Recommended Operating Conditions

Parameter	Symbol	Rating		Unit	Remarks
		min.	max.		
Motor Supply Voltage	V_M		44	V	
Driver Supply Voltage	V_{BB}	10	44	V	
Logic Supply Voltage	V_{DD}	3.0	5.5	V	The V_{DD} surge voltage should be 0.5 V or lower
Case Temperature	T_C		90	$^\circ C$	Temperature at Pin-12 Lead (without heatsink)

■Electrical Characteristics

Parameter	Symbol	Ratings			Unit	Conditions
		min.	typ.	max.		
Main Supply Current	I_{BB}		15		mA	In operation
	I_{BBS}			100	μA	Sleep 1 and Sleep 2 modes
Logic Supply Current	I_{DD}			5	mA	
Output MOSFET Breakdown Voltage	$V_{(BR)DSS}$	100			V	$V_{BB}=44V, I_D=1mA$
Output MOSFET ON Resistance	$R_{DS(ON)}$		0.7	0.85	Ω	SLA7070M, $I_D=1.0A$
			0.45	0.6		SLA7071M, $I_D=1.5A$
			0.25	0.4		SLA7072M, $I_D=2.0A$
			0.18	0.24		SLA7073M, $I_D=3.0A$
Output MOSFET Diode Forward Voltage	V_F		0.85	1.1	V	SLA7070M, $I_D=1.0A$
			1.0	1.25		SLA7071M, $I_D=1.5A$
			0.95	1.2		SLA7072M, $I_D=2.0A$
			0.95	2.1		SLA7073M, $I_D=3.0A$
						When Clock Duty = 50%
Maximum Clock Frequency	F_{clock}	250			kHz	
Logic Input Voltage	V_{IL}			0.25VDD	V	
	V_{IH}	0.75VDD				
Logic Input Current	I_{IL}		± 1		μA	
	I_{IH}		± 1			
REF Input Voltage	V_{REF}		0.04	0.3	V	SLA7070M, within the current setting range
			0.04	0.45		SLA7071M, within the current setting range
			0.04	0.4		SLA7072M, within the current setting range
			0.04	0.45		SLA7073M, within the current setting range
	V_{REFS}	2		VDD		Output OFF (Sleep 1)
REF Input Current	I_{REF}		± 10		μA	
Sense Voltage	V_{SENSE}		V_{REF}		V	When step reference current ratio is 100%
Sleep-Enable Recovery Time	T_{SE}	100			μS	Sleep1&Sleep2
Switching Time	t_{con}		2.0		μS	Clock \rightarrow Out ON
	t_{off}		1.5			Clock \rightarrow Out OFF
Sense Resistance	R_S		0.296	0.305	Ω	SLA7070M, tolerance of $\pm 3\%$
			0.296	0.305		SLA7071M, tolerance of $\pm 3\%$
			0.199	0.205		SLA7072M, tolerance of $\pm 3\%$
			0.150	0.155		SLA7073M, tolerance of $\pm 3\%$
Overcurrent Sense Voltage	V_{ocp}		0.65	0.7	V	SLA7070xMPR, MPRT, when motor coil shorts out
				2.3		SLA7070MPR, MPRT/7071MPR, MPRT
Overcurrent Sense Current	I_{ocp}			3.5	A	SLA7072MPR, MPRT
				4.6		SLA7073MPR, MPRT
				140		SLA707xMPRT, Rear of case (at the saturation temperature)
Flag Output Voltage	V_{FlagL}			1.25	V	SLA707xMPR, MPRT, $I_{FlagL}=1.25mA$
	V_{FlagH}	1.25-VDD				SLA707xMPR, MPRT, $I_{FlagH}=-1.25mA$
Flag Output Current	I_{FlagL}			1.25	mA	SLA707xMPR, MPRT
	I_{FlagH}	-1.25				
Step Reference Current Ratio	ModeF		100		%	
	Mode8		70.7			
PWM Minimum ON Time	$t_{on(min)}$		3.2		μS	
PWM OFF Time	t_{off}		12		μS	

* The direction in which current flows out of the device is regarded as negative.

SLA7080MPR/7081MPR/7082MPR/7083MPR 2-Phase/1-2-Phase Excitation

■ Features

- Lineup of built-in current sense resistor and built-in protection circuit-type
- Power supply voltages, VBB: 46 V (max), 10 to 44 V normal operating range
- Logic supply voltages, VDD: 3.0 to 5.5 V
- Maximum output current I_o: 1A, 1.5A, 2A, and 3A
- Self-excitation PWM current control with fixed off time
- Synchronous PWM chopping function prevents motor noise in Hold mode
- Sleep mode for reducing the IC input current in stand-by state
- ZIP type 23-pin molded package (SLA package)

■ Absolute Maximum Ratings

(T_a=25°C)

Parameter	Symbol	Ratings	Unit	Conditions
Motor Supply Voltage	V _M	46	V	
Driver Supply Voltage	V _{BB}	46	V	
Logic Supply Voltage	V _{DD}	6	V	
Output Current	I _o	*1	A	
Logic Input Voltage	V _{IN}	-0.3 to V _{DD} +0.3	V	
REF Input Voltage	V _{REF}	-0.3 to V _{DD} +0.3	V	
Sense Voltage	V _{RS}	±2	V	Excluding t _w <1μs
Power Dissipation	P _D	4.7	W	When T _a = 25°C
		17		When T _c = 25°C
Junction Temperature	T _j	+150	°C	
Operating Ambient Temperature	T _a	-20 to +85	°C	
Storage Temperature	T _{stg}	-30 to +150	°C	

*1: Output current value may be limited for the SLA7080MPR(1.0A), SLA7081MPR(1.5A), SLA7082MPR(2.0A), SLA7083MPR(3.0A), depending on the duty ratio, ambient temperature, and heating conditions. Do not exceed junction temperature of T_j under any circumstances.

■ Recommended Operating Conditions

Parameter	Symbol	Ratings		Unit	Conditions
		min.	max.		
Motor Supply Voltage	V _M		44	V	
Driver Supply Voltage	V _{BB}	10	44	V	
Logic Supply Voltage	V _{DD}	3.0	5.5	V	The V _{DD} surge voltage should be 0.5V or lower.
REF Input Voltage	V _{REF}	0.04	0.3	V	When controlling the current for SLA7080M
			0.45		When controlling the current for SLA7081M/SLA7083M
			0.4		When controlling the current for SLA7082M
Case Temperature	T _c		90	°C	Rear center (without Fin)

■ Electrical Characteristics

(V_{DD}=5V, V_{BB}=24V, T_a=25°C, unless otherwise specified)

Parameter	Symbol	Ratings			Unit	Conditions	
		min.	typ.	max.			
Main Supply Current	I _{BB}			15	mA	In operation	
	I _{BBS}			100		Sleep Mode	
Logic Supply Current	I _{DD}			5	mA		
Output MOSFET Breakdown Voltage	V _{(BR)DSS}	100			V	V _{BB} =44V, I _D =1mA	
Output MOSFET ON Resistance	R _{DS(ON)}		0.7	0.85	Ω	SLA7080M, I _D =1.0A	
			0.45	0.6		SLA7081M, I _D =1.5A	
			0.25	0.4		SLA7082M, I _D =2.0A	
			0.18	0.24		SLA7083M, I _D =3.0A	
			0.85	1.1		SLA7080M, I _D =1.0A	
Output MOSFET Diode Forward Voltage	V _F		1.0	1.25	V	SLA7081M, I _D =1.5A	
			0.95	1.2		SLA7082M, I _D =2.0A	
			0.95	2.1		SLA7083M, I _D =3.0A	
						When Duty = 50%	
Maximum Clock Frequency	F _{clk}	250			kHz		
Logic Input Voltage	V _{IL}			0.25V _{DD}	V		
	V _{IH}	0.75V _{DD}					
Logic Input Current	I _{IL}		±1		μA		
	I _{IH}		±1				
REF Input Voltage	V _{REF}		0.04	0.3	V	SLA7080M	
			0.04	0.45		SLA7081M	
			0.04	0.4		SLA7082M	
			0.04	0.45		SLA7083M	
			V _{REFS}	2.0		V _{DD}	Sleep ("I _{BBS} ", "output: OFF")
REF Input Current	I _{REF}		±10		μA		
Sense Voltage	V _{SENSE}	V _{REF} -0.03	V _{REF}	V _{REF} +0.03	V		
Sense Resistance	R _s		0.296	0.305	Ω	Including the resistance due to the product configuration (about 5 mΩ) for SLA7080M	
			0.296	0.305		Including the resistance due to the product configuration (about 5 mΩ) for SLA7081M	
			0.199	0.205		0.211	Including the resistance due to the product configuration (about 5 mΩ) for SLA7082M
			0.150	0.155		0.160	Including the resistance due to the product configuration (about 5 mΩ) for SLA7083M
PWM Minimum ON Time (blanking time)	ton(min)		3.2		μs	B_SEL: Low	
PWM OFF Time	t _{off}		5.2		μs	B_SEL: High	
Sleep-Enable Recovery Time	T _{SE}	100			μs	Sleep	
Switching Time	t _{con}		1.5		μs	Phase IN → Out ON	
	t _{coff}		1.0			Phase IN → Out OFF	
Overcurrent Sense Voltage	V _{ocp}	0.65	0.7	0.75	V	When the motor coil shorts out	
Overcurrent Sense Current V _{ocp} +R _s	I _{ocp}		2.3		A	SLA7080MPR/7081MPR	
			3.5			SLA7082MPR	
			4.5			SLA7083MPR	
Blank time for load open	t _{opp}	1.5	2.0	2.5	μs		
Thermal Protection Temperature	T _{isd}		140		°C	Rear of case (at the saturation temperature)	
Flag Output Voltage	V _{FlagL}			1.25	V	I _{FlagL} = 1.25mA	
	V _{FlagH}	1.25V _{DD}				I _{FlagH} = -1.25mA	
Flag Output Current	I _{FlagL}			1.25	mA		
	I _{FlagH}	-1.25					

*The direction in which current flows out of the device is regarded as negative.

Internal Block Diagram

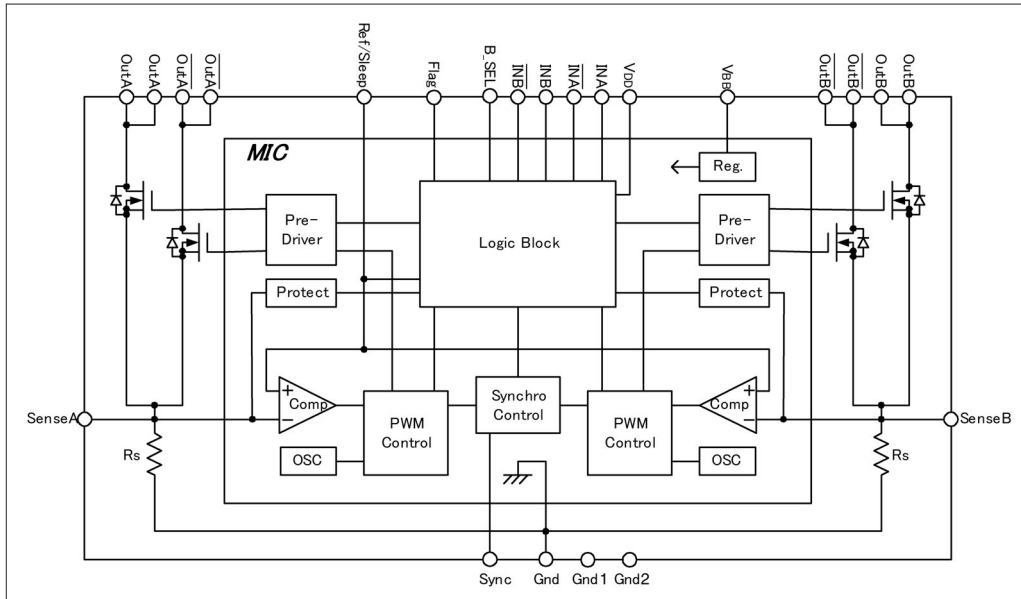

Pin Assignment

Pin No.	Symbol	Function
1		
2	Out A	Phase A output
3	/Out A	Phase A output
4	Sense A	Phase A current sense
6	B_SEL	Blanking time switching input
7	INA	Phase A switching input
8	/INA	
9	INB	Phase B switching input
10	/INB	
11	Vss	Driver supply (motor supply)
12	Gnd	Device GND
13	Ref/Sleep	Control current/Sleep setting input
14	Vdd	Logic supply
15	Gnd1	Gnd1
16	Gnd2	Gnd2
17	Sync	PWM synchronous/asynchronous switching input
18	Flag	Protection circuit monitor output
19	Sense B	Phase B current sense
20	/Out B	Phase B output
21		
22	Out B	Phase B output
23		

Typical Connection Diagram

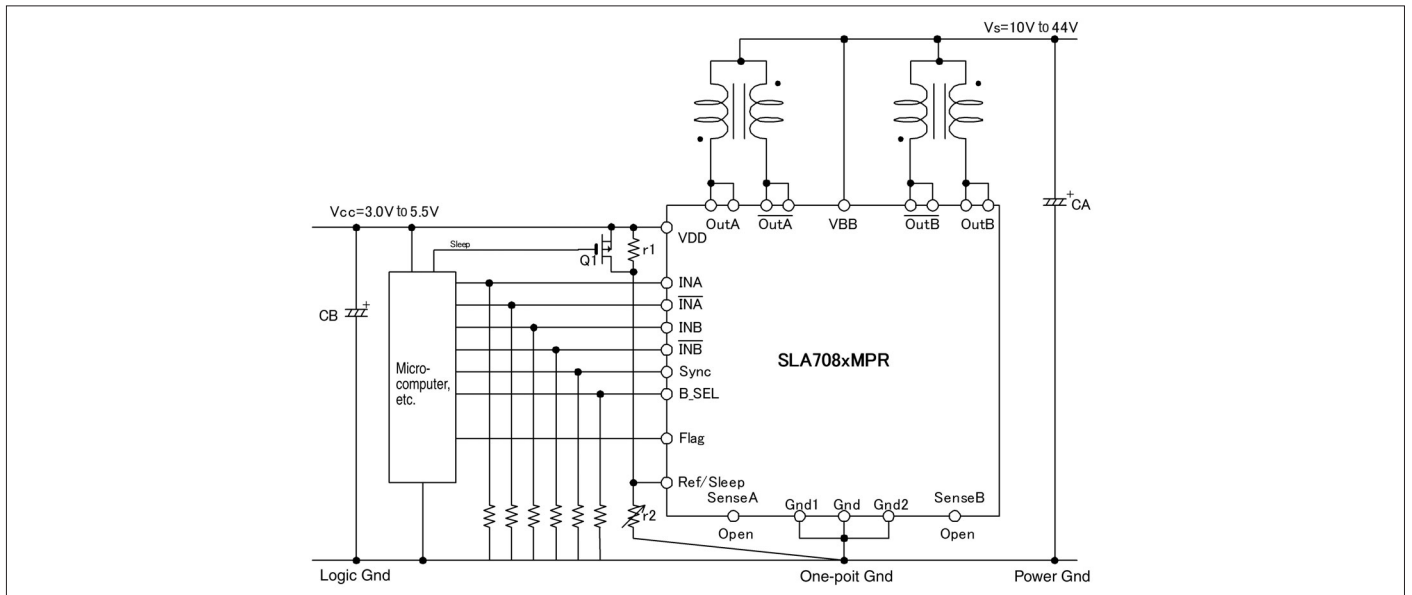

External Dimensions (ZIP23 with Fin [SLA23Pin])

(Unit : mm)

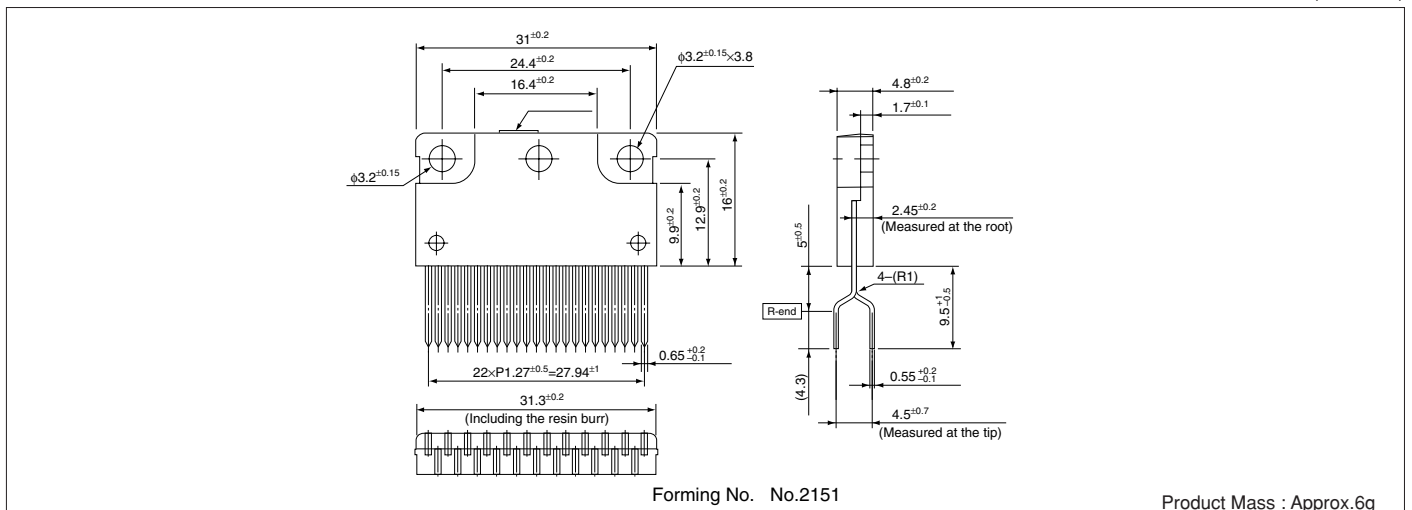

Forming No. No.2151

Product Mass : Approx.6g

STA7130MPR/7131MPR/7132MPR 2-Phase to 2W 1-2 Phase Excitation Support, Built-in Sequencer

Features

- Lineup of built-in current sense resistor and built-in protection circuit-type
- Power supply voltages, V_{BB} : 46 V (max), 10 to 44 V normal operating range
- Maximum output currents: 1 A, 1.5 A, and 2 A
- Supporting the clock-input-method micro-step drive (built-in sequencer)
- Self-excitation PWM current control with fixed off time
- Synchronous PWM chopping function prevents motor noise in Hold mode
- Sleep mode for reducing the IC input current in stand-by state
- ZIP type 18-pin molded package (STA package)

Absolute Maximum Ratings

($T_a=25^\circ\text{C}$)

Parameter	Symbol	Ratings	Unit	Remarks
Motor Supply Voltage	V_M	46	V	
Driver Supply Voltage	V_{BB}	46	V	
Output Current	I_o	*1	A	Mode F
Logic Input Voltage	V_{IN}	-0.3 to +6	V	
REF Input Voltage	V_{REF}	-0.3 to +6	V	
Sense Voltage	V_{RS}	± 0.5	V	Excluding $t_w < 1\mu\text{s}$
Power Dissipation	PD	3.5	W	When $T_a = 25^\circ\text{C}$
		12.5		When $T_c = 25^\circ\text{C}$
Junction Temperature	T_j	+150	$^\circ\text{C}$	
Operating Ambient Temperature	T_a	-20 to +80	$^\circ\text{C}$	
Storage Temperature	T_{stg}	-30 to +150	$^\circ\text{C}$	

*1: Output current value may be limited for the STA7130MPR (1.0 A), 7131MPR (1.5 A), and 7132MPR (2.0 A), depending on the duty ratio, ambient temperature, and heating conditions. Do not exceed junction temperature of T_j under any circumstances.

Recommended Operating Conditions

Parameter	Symbol	Rating		Unit	Remarks
		min.	max.		
Motor Supply Voltage	V_M		44	V	
Driver Supply Voltage	V_{BB}	10	44	V	
Case Temperature	T_c		85	$^\circ\text{C}$	Temperature at Pin-10 Lead (without Fin)

Electrical Characteristics

($V_{DD}=5V$, $V_{BB}=24V$, $T_a=25^\circ\text{C}$, unless otherwise specified)

Parameter	Symbol	Ratings			Unit	Conditions
		min.	typ.	max.		
Main Supply Current	I_{BB}			10	mA	In operation
	I_{BS}			3		Sleep 1 and Sleep 2 modes
Output MOSFET Breakdown Voltage	$V_{(BR)DSS}$	100			V	
Output MOSFET ON Resistance	$R_{DS(ON)}$		0.7	0.85	Ω	STA7130MPR
			0.25	0.4		STA7131MPR
			0.18	0.24		STA7132MPR
Output MOSFET Diode Forward Voltage	V_F		0.85	1.1	V	STA7130MPR
			0.95	1.2		STA7131MPR
			0.95	2.1		STA7132MPR
Maximum Clock Frequency	F_{clock}	250			kHz	When Clock Duty = 50%
Logic Input Voltage	V_{IL}			0.7	V	
	V_{IH}	2.3				
Logic Input Current	I_{IL}		± 10		μA	
	I_{IH}		± 10			
REF Input Voltage	V_{REF}	0		0.9	V	
	V_{REFS}	2.0		5.5		Output OFF (Sleep 1)
REF Input Current	I_{REF}		± 10		μA	
Sense Voltage	V_{SENSE}	$V_{REF}/3-0.03$	$V_{REF}/3$	$V_{REF}/3+0.03$	V	When step reference current ratio is 100%
Sleep-Enable Recovery Time	T_{SE}	100			μs	Sleep1&Sleep2
Switching Time	t_{con}		1.4		μs	Clock \rightarrow Out ON
	t_{coff}		0.7			Clock \rightarrow Out OFF
Sense Resistance	R_s		0.305		Ω	STA7130MPR
			0.205			STA7131MPR
			0.155			STA7132MPR
Overcurrent Sense Voltage	V_{ocp}	0.65	0.7	0.75	V	When motor coil shorts out
Overcurrent Sense Current $V_{ocp}+R_s$	I_{ocp}		2.3		A	STA7130MPR
			3.5			STA7131MPR
			4.5			STA7132MPR
Thermal Protection Temperature	T_{tsd}		125		$^\circ\text{C}$	Rear of case (at the saturation temperature)
Logic Output Voltage	V_{LLOL}			0.8	V	$I_{LOL} = 5\text{mA}$
Logic Output Current	I_{LOL}			5	mA	$V_{LLOL} = 0.8V$
Step Reference Current Ratio	ModeF		100		%	$V_{REF}=0.1V$ to $0.9V$
	ModeE		98.1			
	ModeC		92.4			
	ModeA		83.1			
	Mode8		70.7			
	Mode6		55.5			
	Mode4		38.2			
	Mode2		19.5			
PWM Minimum ON Time	$t_{on(min)}$		1.5		μs	
	t_{off1}		11.5			Mode 8 to F
PWM OFF Time	t_{off2}		8.5		μs	Mode 4 to 6
	t_{off3}		7			Mode 2

*The direction in which current flows out of the device is regarded as negative.

Internal Block Diagram



Pin Assignment

Pin No.	Symbol	Function
1	OutA	Phase A output
2	OutA/	Phase A output
3	SenseA	Phase A current sense
4	Mo	2 phase excitation state output monitor output
5	M1	Excitation mode setting input
6	M2	
7	Sleep2	Sleep 2 setting input
8	Clock	Step Clock input
9	VDD	Driver supply (motor supply)
10	Gnd	Device GND
11	Ref/Sleep1	Control current mode/Sleep 1 setting input
12	Reset	Internal logic reset input
13	CW/CCW	Normal/reverse control input
14	Sync	PWM control signal input
15	Flag	Coil open/shorted detection output
16	SenseB	Phase B current sense
17	OutB/	Phase B output
18	OutB	Phase B output

Typical Connection Diagram



External Dimensions (ZIP18 with Fin [STA18Pin])

(Unit : mm)



SI-7321M 2-Phase to 4W 1-2 Phase Excitation Support, Built-in Sequencer

Features

- Power supply voltages, VBB: 46 V (max), 10 to 44 V normal operating range
- Logic supply voltages, VDD: 3.0 to 5.5 V
- Output Current I_o: 1.5A
- Clock input method (built-in sequencer)
- Self-excitation PWM current control with fixed off time
- Synchronous PWM chopping function prevents motor noise in Hold mode
- Sleep mode for reducing the IC input current in stand-by state
- Selectable blanking time (1.8 us or 3.6 us)
- Selectable clock input edge (POS or POS/NEG)
- Selectable protection availability
- 44-pin surface-mount

Absolute Maximum Ratings

(T_a=25°C)

Parameter	Symbol	Ratings	Unit	Conditions
Motor Supply Voltage	V _M	46	V	
Driver Supply Voltage	V _{BB}	46	V	
Logic Supply Voltage	V _{DD}	6	V	
Output Current	I _o	1.5	A	Current ratio: Mode F
Logic Input Voltage	V _{IN}	-0.3 to V _{DD} +0.3	V	
REF Input Voltage	V _{REF}	-0.3 to V _{DD} +0.3	V	
Sense Voltage	V _{RS}	±2	V	Excluding tw<1μs
Power Dissipation	P _D	3.5	W	When T _a = 25°C
Junction Temperature	T _J	+150	°C	
Operating Ambient Temperature	T _a	-20 to +80	°C	
Storage Temperature	T _{stg}	-30 to +150	°C	

*: Output current value may be limited, depending on the duty ratio, ambient temperature, and heating conditions.

Do not exceed junction temperature of T_J under any circumstances.

Recommended Operating Conditions

Parameter	Symbol	Ratings		Unit	Conditions
		min.	max.		
Motor Supply Voltage	V _M		44	V	
Driver Supply Voltage	V _{BB}		44	V	
Logic Supply Voltage	V _{DD}	3.3	5.5	V	The V _{DD} surge voltage should be 0.5V or lower.
REF Input Voltage	V _{REF}	0.04	1.0	V	When not using protection
			0.5		When using protection
Case Temperature	T _c		85	°C	Temperature at the center of the package

Electrical Characteristics

(V_{DD}=5V, V_{BB}=24V, T_a=25°C, unless otherwise specified)

Parameter	Symbol	Ratings			Unit	Conditions
		min.	typ.	max.		
Driver Supply Current	I _{BB}			15	mA	In operation
	I _{BBSS}			100	μA	Sleep Mode
Logic Supply Current	I _{DD}			5	mA	
Output MOSFET Breakdown Voltage	V _{(BR)DSS}	100			V	V _{BB} =44V, I _D =1mA
Output MOSFET ON Resistance	R _{DS(ON)}		0.25	0.4	Ω	I _D =1.5A
Output MOSFET Diode Forward Voltage	V _F		0.95	1.2	V	I _F =1.5A
Maximum Clock Frequency	F _{clk}	250			kHz	When Duty = 50%
Logic Input Voltage	V _{IL}			0.25V _{DD}	V	
	V _{IH}	0.75V _{DD}				
Logic Input Current	I _{IL}		±1		μA	
	I _{IH}		±1			
REF Input Voltage	V _{REF}	0.04		1.5	V	When not using protection
		0.04		0.6		When using protection
	V _{REFS}	2		V _{DD}		Sleep1 Mode
REF Input Current	I _{REF}		±10		μA	V _{REF} =0 to V _{DD}
Logic Output Voltage	V _{LLOL}			1.25	V	I _{LLOL} =1.25mA
	V _{LLOH}	V _{DD} -1.25			V	I _{LLOH} =-1.25mA
Logic Output Current	I _{LLOL}			1.25	mA	
	I _{LLOH}	-1.25			mA	
Sense Voltage	V _{SENSE}		0.2		V	V _{REF} =0.2V, Mode F
Overcurrent Sense Voltage	V _{ocp}	0.65		0.75	V	against V _{sense}
Step Reference Current Ratio	Mode F		100		%	V _{REF} =0.04V to 1.5V
	Mode E		98.1		%	
	Mode D		95.7		%	
	Mode C		92.4		%	
	Mode B		88.2		%	
	Mode A		83.1		%	
	Mode 9		77.3		%	
	Mode 8		70.7		%	
	Mode 7		63.4		%	
	Mode 6		55.5		%	
	Mode 5		47.1		%	
	Mode 4		38.2		%	
	Mode 3		29.0		%	
Mode 2		19.5		%		
Mode 1		9.8		%		
Sleep-Enable Recovery Time	T _{SE}	100			μS	Sleep1&Sleep2
Switching Time	tp _{don1}		2.0		μS	Clock → Out ON
			1.5		μS	Clock → Out OFF
PWM Minimum ON Time	ton(min)		1.8		μS	B_SEL: L
			3.6		μS	B_SEL: H
PWM OFF Time	toff1		13		μS	Mode8 to F
			9.5		μS	Mode4 to 7
			7.5		μS	Mode1 to 3
Blank time for load open	topp	1.5	2	2.5	μS	Starts when the PWM is turned off.

The direction in which current flows out of the device is regarded as negative.

Internal Block Diagram

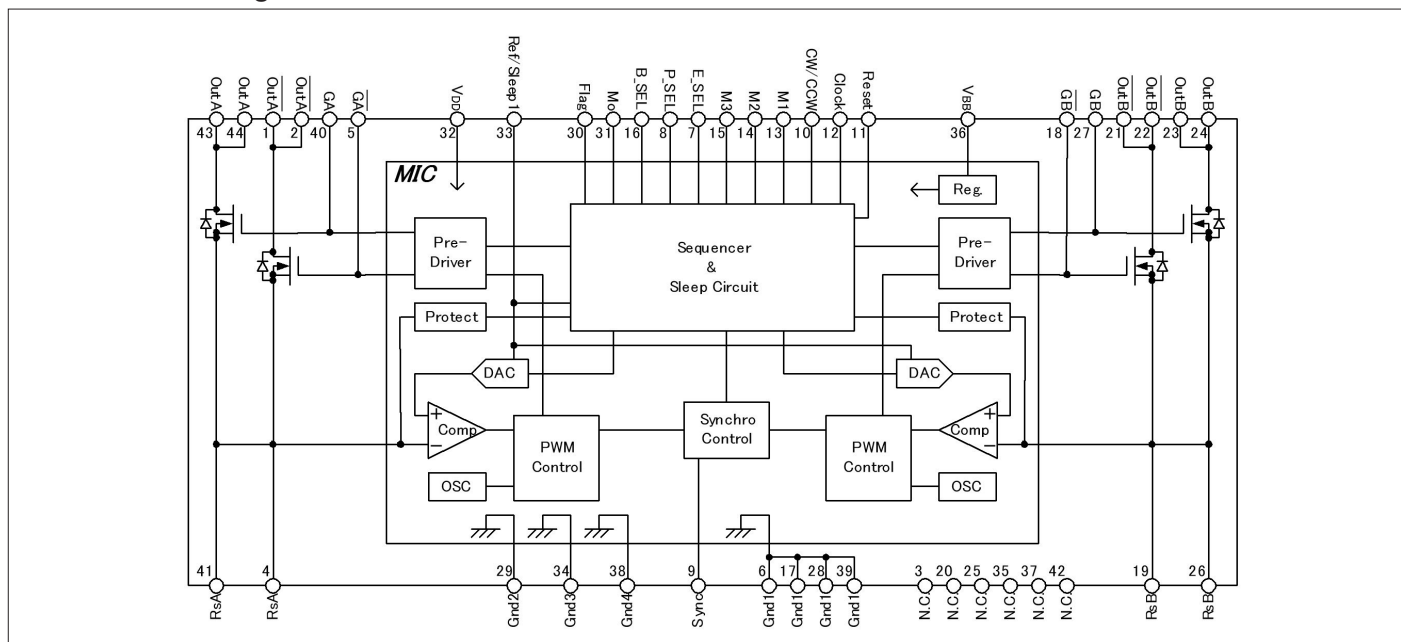

Typical Connection Diagram



Pin Assignment

Pin No.	Symbol	Function
1	Out/A	Phase A output
2	Out/A	Phase A output
3	N.C.	No connection
4	RsA	Connection terminal for phase A sense resistor
5	G/A	Phase A MOSFET gate
6	Gnd1	Device Gnd1
7	E_SEL	Edge selection input
8	P_SEL	Protection use selection input
9	Sync	PWM control signal input
10	CW/CCW	Normal/reverse control input
11	Reset	Internal logic reset input
12	Clock	Step clock input
13	M1	Excitation mode/Sleep 2 setting input
14	M2	
15	M3	
16	B_SEL	Blanking time selection input
17	Gnd1	Device Gnd1
18	G/B	Phase B MOSFET gate
19	RsB	Connection terminal for phase B sense resistor
20	N.C.	No connection
21	Out/B	Phase B output
22	Out/B	Phase B output
23	OutB	Phase B output
24	OutB	Phase B output
25	N.C.	No connection
26	RsB	Connection terminal for phase B sense resistor
27	GB	Phase B MOSFET gate
28	Gnd1	Device Gnd1
29	Gnd2	Device Gnd2
30	Flag	Protection circuit monitor output
31	Mo	2-phase excitation state monitor output
32	VDD	Logic supply
33	Ref/Sleep1	Control current mode/Sleep 1 setting input
34	Gnd3	Device Gnd3
35	N.C.	No connection
36	VBB	Driver supply (motor supply)
37	N.C.	No connection
38	Gnd4	Device Gnd4
39	Gnd1	Device Gnd1
40	G/A	Phase A MOSFET gate
41	RsA	Connection terminal for phase A sense resistor
42	N.C.	No connection
43	Out A	Phase A output
44	Out A	Phase A output

External Dimensions (HSOP44)

(Unit : mm)

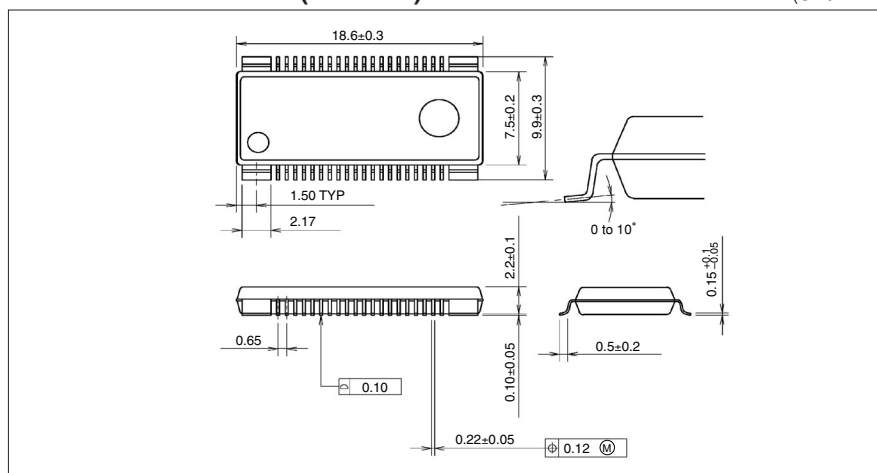

SLA7075MR, MPR, MPRT/7076MR, MPR, MPRT/7077MR, MPR, MPRT/7078MR, MPR, MPRT 2-Phase to 4W 1-2 Phase Excitation Support, Built-in Sequencer

☆ For new designs, use SLA707xMPRT.

Features

- Lineup of built-in current sense resistor and built-in protection circuit-type
- Power supply voltages, V_{BB} : 46 V (max), 10 to 44 V normal operating range
- Logic supply voltages, V_{DD} : 3.0 to 5.5 V
- Maximum output currents: 1 A, 1.5 A, 2 A, and 3 A
- Clock input method (built-in sequencer)
- Self-excitation PWM current control with fixed off-time
- Synchronous PWM chopping function prevents motor noise in Hold mode
- Sleep mode for reducing the IC input current in stand-by state
- ZIP type 23-pin molded package (SLA package)

Absolute Maximum Ratings

Parameter	Symbol	Ratings	Unit	Remarks
Motor Supply Voltage	V_M	46	V	
Driver Supply Voltage	V_{BB}	46	V	
Logic Supply Voltage	V_{DD}	6	V	
Output Current	I_O	*1	A	$V_{ref} = -0.4V$, Mode F
Logic Input Voltage	V_{IN}	-0.3 to $V_{DD} + 0.3$	V	
REF Input Voltage	V_{REF}	-0.3 to $V_{DD} + 0.3$	V	
Sense Voltage	V_{RS}	± 2	V	Excluding $t_w < 1\mu s$
Power Dissipation	PD	4.7	W	When $T_a = 25^\circ C$
		17		When $T_c = 25^\circ C$
Junction Temperature	T_j	+150	$^\circ C$	
Operating Ambient Temperature	T_a	-20 to +85	$^\circ C$	
Storage Temperature	T_{stg}	-30 to +150	$^\circ C$	

*1: Output current value may be limited for the SLA7075MR, MPR, MPRT (1.0 A), SLA7076MR, MPR, MPRT (1.5 A), SLA7077MR, MPR, MPRT (2.0 A), and SA7078MR, MPR, MPRT (3.0 A), depending on the duty ratio, ambient temperature, and heating conditions.

Do not exceed junction temperature of T_j under any circumstances.

Recommended Operating Conditions

Parameter	Symbol	Rating		Unit	Remarks
		min.	max.		
Motor Supply Voltage	V_M		44	V	
Driver Supply Voltage	V_S	10	44	V	
Logic Supply Voltage	V_{DD}	3.0	5.5	V	The V_{cc} surge voltage should be 0.5 V or lower
Case Temperature	T_C		90	$^\circ C$	Temperature at Pin-12 Lead (without heatsink)

Electrical Characteristics

Parameter	Symbol	Ratings			Unit	Conditions
		min.	typ.	max.		
Main Supply Current	I_{BB}			15	mA	In operation Sleep 1 and Sleep 2 modes
	I_{BBS}			100		
Logic Supply Current	I_{DD}			5	mA	
Output MOSFET Breakdown Voltage	$V_{(BR)DSS}$	100			V	$V_{BB} = 44V$, $I_O = 1mA$
Output MOSFET ON Resistance	$R_{DS(ON)}$		0.7	0.85	Ω	SLA7075M, $I_D = 1.0A$
			0.45	0.6		SLA7076M, $I_D = 1.5A$
			0.25	0.4		SLA7077M, $I_D = 2.0A$
			0.18	0.24		SLA7078M, $I_D = 3.0A$
Output MOSFET Diode Forward Voltage	V_F		0.85	1.1	V	SLA7075M, $I_D = 1.0A$
			1.0	1.25		SLA7076M, $I_D = 1.5A$
			0.95	1.2		SLA7077M, $I_D = 2.0A$
			0.95	2.1		SLA7078M, $I_D = 3.0A$
Maximum Clock Frequency	F_{clock}	250			kHz	When Clock Duty = 50%
Logic Input Voltage	V_{IL}			$0.25V_{DD}$	V	
	V_{IH}	$0.75V_{DD}$				
Logic Input Current	I_{IL}		± 1		μA	
	I_{IH}		± 1			
REF Input Voltage	V_{REF}	0.04		0.3	V	SLA7075M, within the specified current limit
		0.04		0.45		SLA7076M, within the specified current limit
		0.04		0.4		SLA7077M, within the specified current limit
		0.04		0.45		SLA7078M, within the specified current limit
	V_{REFS}	2		V_{DD}		Output (OFF) Sleep 1
REF Input Current	I_{REF}		± 10		μA	
SENSE Sense Voltage	V_{SENSE}		V_{REF}		V	When step reference current ratio is 100%
Sleep-Enable Recovery Time	T_{SE}	100			μs	Sleep1 & Sleep2
Switching Time	t_{con}		2.0		μs	Clock \rightarrow Out ON
	t_{coff}		1.5			Clock \rightarrow Out OFF
Sense Resistance	R_S	0.296	0.305	0.314	Ω	SLA7075M, tolerance of $\pm 3\%$
		0.296	0.305	0.314		SLA7076M, tolerance of $\pm 3\%$
		0.199	0.205	0.211		SLA7077M, tolerance of $\pm 3\%$
		0.150	0.155	0.160		SLA7078M, tolerance of $\pm 3\%$
Overcurrent Sense Voltage	V_{ocp}	0.65	0.7	0.75	V	SLA707xMPR, MPRT, when motor coil shorts out
			2.3			SLA7075MPR, MPRT/7076MPR, MPRT
Overcurrent Sense Current	I_{ocp}		3.5		A	SLA7077MPR, MPRT
			4.6			SLA7078MPR, MPRT
			140			SLA707xMPRT, Rear of case (at the saturation temperature)
Logic Output Voltage	V_{LOL}			1.25	V	SLA707xMPR, MPRT, $I_{FlagL} = 1.25mA$
	V_{LOH}	$V_{DD} - 1.25$				SLA707xMPR, MPRT, $I_{FlagH} = -1.25mA$
Logic Output Current	I_{LOL}			1.25	mA	SLA707xMPR, MPRT
	I_{LOH}	-1.25				
Step Reference Current Ratio	ModeF		100		%	
	ModeE		98.1		%	
	ModeD		95.7		%	
	ModeC		92.4		%	
	ModeB		88.2		%	
	ModeA		83.1		%	
	Mode9		77.3		%	
	Mode8		70.7		%	
	Mode7		63.4		%	
	Mode6		55.5		%	
	Mode5		47.1		%	
	Mode4		38.2		%	
	Mode3		29.0		%	
PWM Minimum ON Time	$t_{on(min)}$		1.7		μs	
	t_{off1}		12			Mode 8 to F
	t_{off2}		9			Mode 4 to 7
PWM OFF Time	t_{off3}		7		μs	Mode 1 to 3

Internal Block Diagram



The protect circuit is deleted and the flag pin is N.C. for SLA7075MR, 7076MR, 7077MR, and 7078MR.

Pin Assignment

Pin No.	Symbol	Function
1		
2	OutA	Phase A output
3		
4	OutA/	Phase A output
5	SenseA	Phase A current sense
6	Mo	2 phase excitation state output monitor output
7	M1	Excitation mode/Sleep 2 setting input
8	M2	
9	M3	
10	Clock	Step Clock input
11	VDD	Driver supply (motor supply)
12	GND	Device GND
13	Ref/Sleep1	Control current mode/Sleep 1 setting input
14	VDD	Logic supply
15	Reset	Internal logic reset input
16	CW/CCW	Normal/reverse control input
17	Sync	PWM control signal input
18	Flag ¹	Protection circuit monitor output ¹
19	SenseB	Phase B current sense
20		
21	OutB/	Phase B current output
22		
23	OutB	Phase B current output

*1: N.C. pin for SLA7075MR, 7076MR, 7077MR, and 7078MR.

Typical Connection Diagram



* There is no Flag pin (pin 18) for SLA7075MR, 7076MR, 7077MR, and 7078MR.

External Dimensions (ZIP23 with Fin [SLA23Pin])

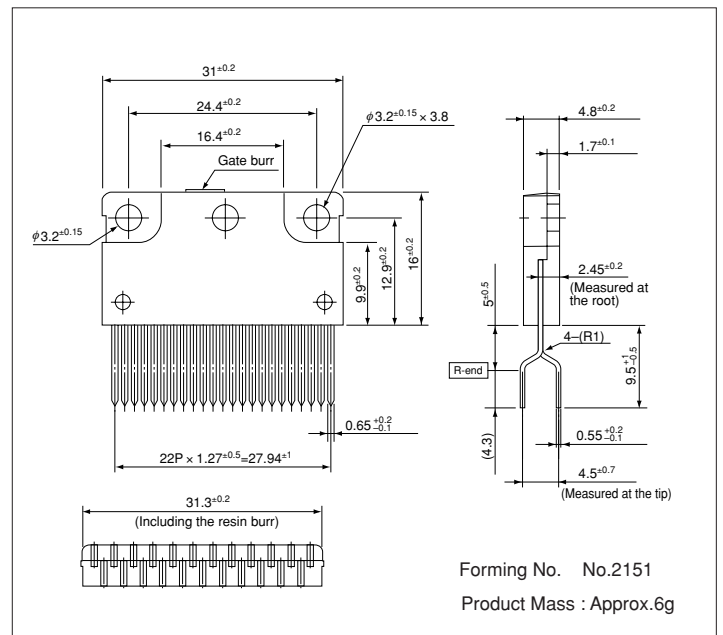

Forming No. No.2151
Product Mass : Approx.6g

SI-7510 New Pentagon Connection

Absolute Maximum Ratings

Parameter	Symbol	Ratings	Unit	Remarks
Main Supply Voltage	V _{CC1}	44	V	
Logic Supply Voltage	V _{CC2}	7	V	
Logic Input Voltage	V _{IN}	-0.3 to V _{CC2}	V	
REF Input Voltage	V _{REF}	-0.3 to V _{CC2}	V	
Sense Input Voltage	V _{SENSE}	2	V	Except when $t_w < 1\mu s$
Charge Pump Output Voltage	V _{MC3}	48	V	
Power Dissipation	P _D	1.6	W	
Operating Ambient Temperature	T _a	-10 to 80	°C	
Storage Temperature	T _{stg}	-20 to 150	°C	
Junction Temperature	T _j	150	°C	

Recommended Operating Ranges

Parameter	Symbol	Operating Ranges	Unit
Main Supply Voltage	V _{CC1}	10 to 42*	V
Logic Supply Voltage	V _{CC2}	3 to 5.5	V
REF Input Voltage	V _{REF}	0.1 to 1	V

*: Insert a 5V Zener diode between V_{CC1} and V_{MC3} when using with V_{CC1} of 35 V or more.

Electrical Characteristics

(T_a=25°C, V_{CC1}=24V, V_{CC2}=5V, unless otherwise specified)

Parameter	Symbol	Ratings			Unit	Conditions
		min.	typ.	max.		
Main Supply Current	I _{CC1}			25	mA	
Logic Supply Current	I _{CC2}			10	mA	
Logic Input Voltage	V _{IL}			1.25	V	
	V _{IH}	3.75			V	
Logic Input Current	I _{IL}	-20		20	μA	V _{IL} =0V
	I _{IH}	-20		20	μA	V _{IH} =5.5V
ENA Input Current	I _{ENA}	-100		20	μA	V _{ENA} =0V
REF Input Current	I _{REF}	-20		20	μA	V _{REF} =0 to 5.5V
SENSE Voltage	V _{SENSE}		1		V	V _{REF} =1V
SENSE Current	I _{SENSE}	-20		20	μA	V _{SENSE} =0V, 2V
MO Output Voltage	V _{MOL}			1	V	I _{MOL} =1mA
	V _{MOH}	4			V	I _{MOH} =-1mA
RC Pin Threshold Voltage	V _{RCL}		0.5		V	
	V _{RCH}		1.5		V	
RC Pin Outflow Current	I _{RC}		300		μA	V _{RC} =0V
Charge Pump Output Voltage	V _{MC3}		V _{CC1} +9		V	
High Side Output Voltage (between gate sources)	V _{HGSL}			1	V	Without Zener diode
	V _{HGSH}		8.5		V	
Low Side Output Voltage	V _{LGL}			1	V	
	V _{LGH}		7.5		V	
Maximum CL Frequency	f _{ck}	100			KHz	
Maximum Input CL Width (on)	T _{CON}	1			μs	
Power-on Reset time	PTW		1.5		μs	
Output Delay Time	T _{IO}		2		μs	
CW/CCW, F/H Input Data Setup Time	T _{ICS}	500			μs	Against CL ↑
CW/CCW, F/H Input Data Hold Time	T _{ICH}	500			μs	

Internal Block Diagram

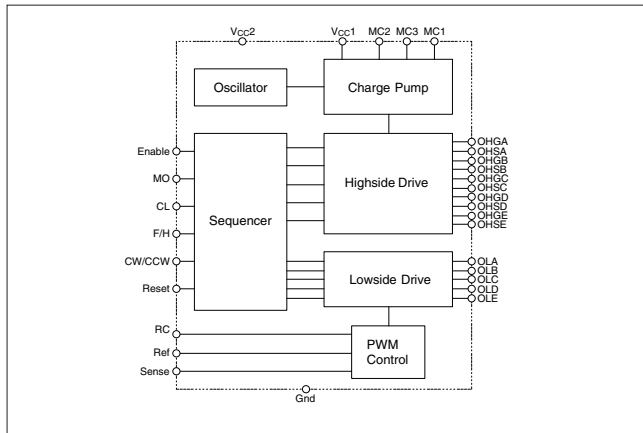

Typical Connection Diagram

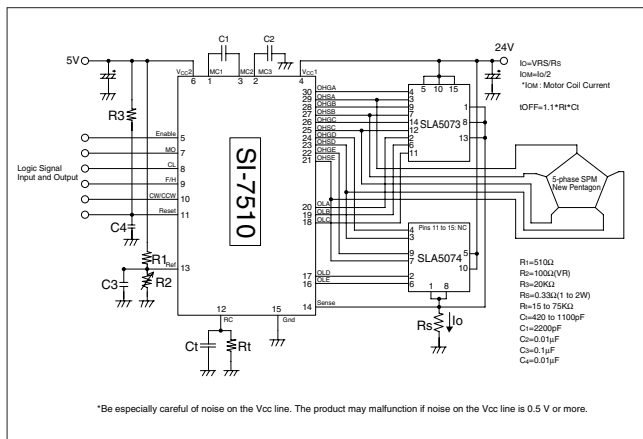

Input and Output Timing Chart

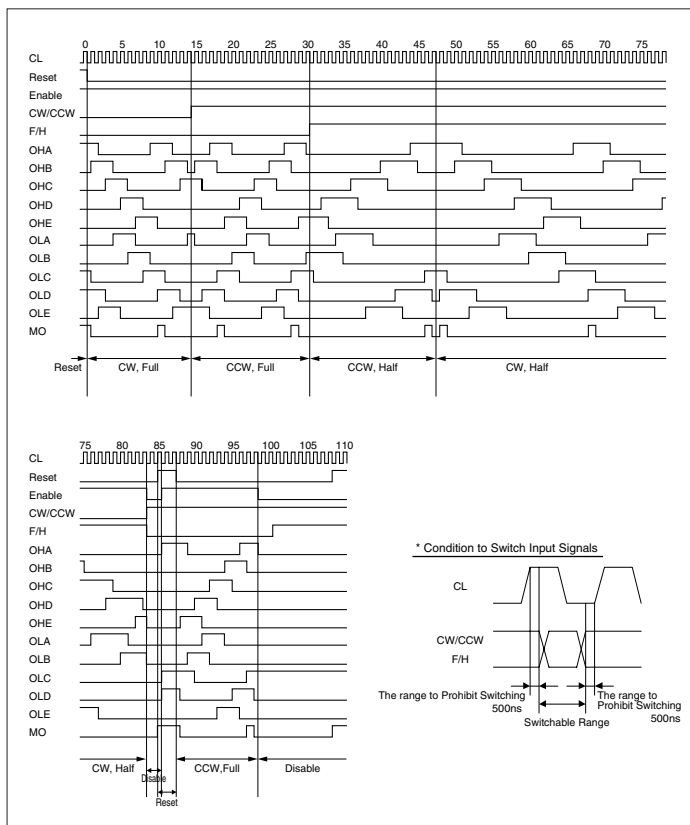

Pin Assignment and Function Table

Pin No.	Symbol	Function
1	MC1	Capacitor Connection Terminal for Charge Pump (for MC2)
2	MC3	Capacitor Connection Terminal for Charge Pump (for Gnd)
3	MC2	Capacitor Connection Terminal for Charge Pump (for MC1)
4	Vcc1	Main Supply Voltage Input
5	Enable	Output OFF
6	Vcc2	Logic Voltage Input
7	MO	Monitor to Detect Motor Position
8	CL	Clock
9	F/H	4-phase, 4-5 phase switching
10	CW/CCW	Switching Between Forward and Backward Rotation
11	Reset	Reset
12	RC	RC Connection for Chopping Off Time Setting
13	Ref	Reference Voltage Input for Motor Current Setting
14	Sense	For Motor Current Detection
15	Gnd	Gnd
16	VOLE	Low Side MOSFET Gate Connection Pin (E-phase)
17	VOLD	Low Side MOSFET Gate Connection Pin (D-phase)
18	VOLC	Low Side MOSFET Gate Connection Pin (C-phase)
19	VOLB	Low Side MOSFET Gate Connection Pin (B-phase)
20	VOLA	Low Side MOSFET Gate Connection Pin (A-phase)
21	VOHSE	High Side MOSFET Source Connection Pin (E-phase)
22	VOHGE	High Side MOSFET Gate Connection Pin (E-phase)
23	VOHSD	High Side MOSFET Source Connection Pin (D-phase)
24	VOHGD	High Side MOSFET Gate Connection Pin (D-phase)
25	VOHSC	High Side MOSFET Source Connection Pin (C-phase)
26	VOHGC	High Side MOSFET Gate Connection Pin (C-phase)
27	VOHSB	High Side MOSFET Source Connection Pin (B-phase)
28	VOHGB	High Side MOSFET Gate Connection Pin (B-phase)
29	VOHSA	High Side MOSFET Source Connection Pin (A-phase)
30	VOHGA	High Side MOSFET Gate Connection Terminal (A-phase)

Truth Table

Pin Name	Low Level	High Level
Clock		Positive Edge
CW/CCW	Forward Rotation (CW)	Backward Rotation (CCW)
Full/Half	4-phase excitation	4-5 phase excitation
Enable	Disable	Enable
Reset	Enable	Reset

External Dimensions (DIP30)

(Unit : mm)

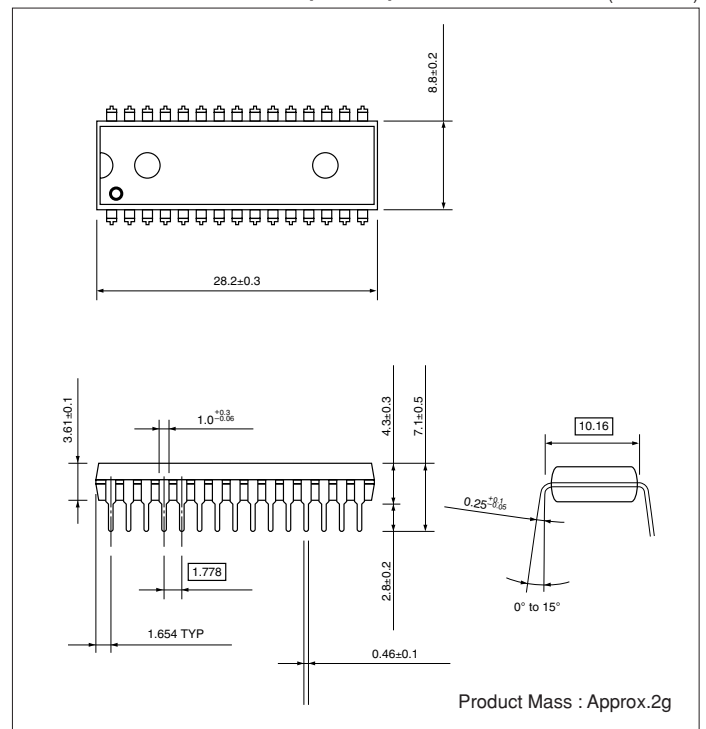

STA6940M

■ Features

- Output current: 4A (peak: 8A)
- Power supply voltage: $V_{BB} = 10$ to 40V
- Logic supply voltage: $V_{DD} = 3.0$ to 5.5V
- Built-in UVLO, OCP, and TSD protection
- Built-in diag output function
- STA 18-pin package

■ Absolute Maximum Ratings

Parameter	Symbol	Ratings	Unit	Conditions
Driver Supply Voltage	V_{BB}	44	V	
Logic Supply Voltage	V_{DD}	6	V	
Output Current	I_o	8	A	100 μ s or less
Logic Input Voltage	V_{IN}	-0.3 to $V_{DD}+0.3$	V	
PWM REF Input Voltage	V_{PREF}	-0.3 to $V_{DD}+0.3$	V	
OCP REF Input Voltage	V_{OREF}	-0.3 to $V_{DD}+0.3$	V	
Sense Voltage	V_{RS}	-1 to 2	V	
Power Dissipation	P_D	2.7	W	DC control ($T_a = 25^\circ\text{C}$)
		3.0	W	PWM control ($T_a = 25^\circ\text{C}$) at Slow Decay
		3.2	W	PWM control ($T_a = 25^\circ\text{C}$) at Fast Decay
Junction Temperature	T_j	150	$^\circ\text{C}$	
Operating Ambient Temperature	T_a	-20 to 85	$^\circ\text{C}$	
Storage Temperature	T_{stg}	-30 to 150	$^\circ\text{C}$	

*: Output current value may be limited, depending on the duty ratio, ambient temperature, and heating conditions. Do not exceed junction temperature of T_j under any circumstances.

■ Recommended Operating Conditions

Parameter	Symbol	Ratings		Unit	Conditions
		min.	max.		
Main Supply Voltage	V_{BB}	10	40	V	
Output Current	I_o		4.0	A	
Logic Supply Voltage	V_{DD}	3.0	5.5	V	
PWM REF Input Voltage	V_{PREF}		1	V	When operating current control
OCP REF Input Voltage	V_{OREF}		2	V	When operating overcurrent control
Case Temperature	T_c		85	$^\circ\text{C}$	Rear center (without Fin)

■ Electrical Characteristics

($V_{DD}=5V$, $V_{BB}=24V$, $T_a=25^\circ\text{C}$, unless otherwise specified)

Parameter	Symbol	Ratings			Unit	Conditions
		min.	typ.	max.		
Main Supply Current	I_{BB}			20	mA	In operation
Logic Supply Current	I_{DD}			5	mA	
Charge Pump Voltage	V_{CP}		$V_{BB}+5$		V	$V_{BB}=10V$ to 40V
Charge Pump Oscillation Frequency	F_{CP}		360		kHz	
Low Driver Supply Voltage Protection Voltage	V_{UVBL}		7		V	
	V_{UVBH}		7.8		V	
Low Logic Supply Voltage Protection Voltage	V_{UVDL}		2.3		V	
	V_{UVDH}		2.5		V	
Low Charge Pump Voltage Protection Voltage	$V_{UVC L}$		3.8		V	against V_{BB}
	$V_{UVC H}$		4		V	
Output MOSFET Breakdown Voltage	$V_{(BR)DS}$	60			V	$I_D=250\mu\text{A}$
Output MOSFET ON Resistance	$R_{DS(ON)}$		0.1	0.13	Ω	$I_D=4.0A$
Output MOSFET Diode Forward Voltage	V_F		0.95	2.1	V	$I_F=4.0A$
Logic Input Voltage	V_{LIL}			0.25 V_{DD}	V	
	V_{LIH}	0.75 V_{DD}			V	
Logic Input Current	I_{LIL}		± 1		μA	
	I_{LIH}		± 1		μA	
Maximum Logic Input Clock Frequency	f_{CLK}	100			kHz	duty=50%
PWM REF Input Voltage	V_{PREF}	0.1		1	V	When controlling the current
PWM REF Input Current	I_{PREF}		± 10		μA	$V_{REF}=0$ to V_{DD}
OCP REF Input Voltage	V_{OREF}	0.1		2	V	When controlling the current
OCP REF Input Current	I_{OREF}		± 10		μA	$V_{REF}=0$ to V_{DD}
PWM Sense Voltage	V_{PSEN}	V_{PREF}	V_{PREF}	V_{PREF}	V	
		-0.045	-0.015	+0.015		
Overcurrent Sense Voltage	V_{OSEN}	V_{OREF}	V_{OREF}	V_{OREF}	V	
		-0.045	-0.015	+0.015		
Sense Input Current	I_{SENSE}		± 20		μA	
Diag Output Voltage	V_{LOL}			1.25	V	$I_{LOL}=1.25\text{mA}$
	V_{LOH}	$V_{DD}-1.25$			V	$I_{LOL}=-1.25\text{mA}$
Diag Output Current	I_{LOL}			1.25	mA	$V_{LOL}=1.25V$
	I_{LOH}	-1.25			mA	$V_{LOH}=V_{DD}-1.25$
Diag Output Frequency	f_{DIAG}		90		kHz	
PWM Minimum ON Time	$t_{pon(min)}$		5		μs	During PWM operation
PWM OFF Time	t_{POFF}		35		μs	
OCP Minimum ON Time	$t_{oon(min)}$		5		μs	During OCP operation
OCP OFF Time	t_{OOFF}		142		μs	
Crossover Current Delay Time	t_{COCD}	150		750	ns	
Switching Time	t_{con}		3		μs	IN \rightarrow Out ON
	t_{coff}		2.7		μs	IN \rightarrow Out OFF
Thermal Protection Activation Temperature	T_{tsdon}		140		$^\circ\text{C}$	Temperature of rear of package (at saturation)
Thermal Protection Deactivation Temperature	T_{tsdoff}		115		$^\circ\text{C}$	

Internal Block Diagram

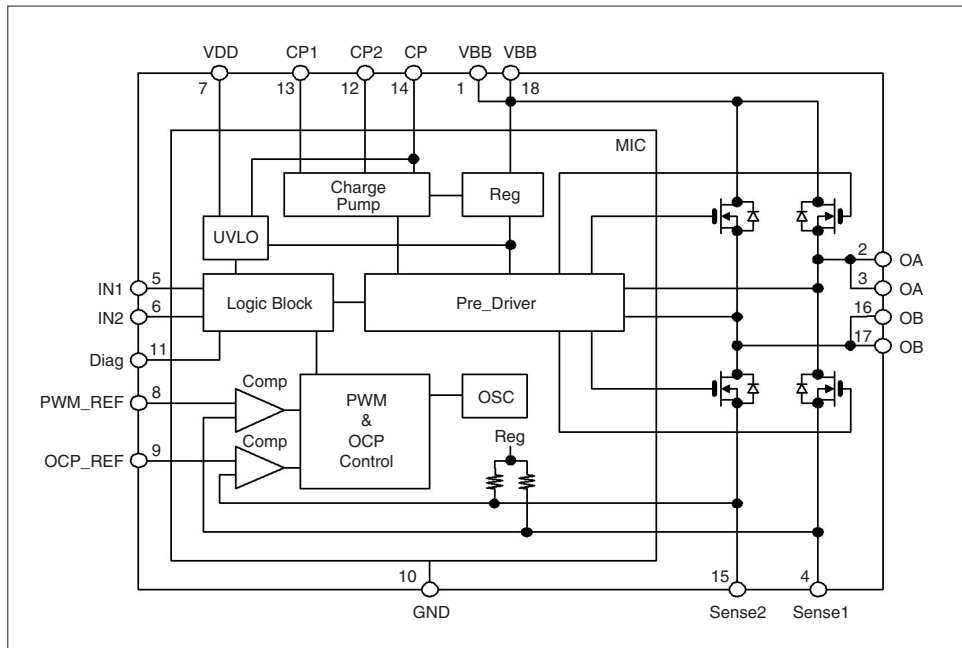

Pin Assignment

Pin No.	Symbol	Function
1	V _{BB}	Main supply
2,3	OA	Output terminal A
4	Sense 1	Constant current sense terminal
5	IN1	Output setting terminal
6	IN2	
7	V _{DD}	Logic supply
8	PWM_REF	Constant current setting input terminal
9	OCP_REF	Overcurrent setting input terminal
10	Gnd	Device Gnd
11	Diag	Monitor terminal
12	CP2	Capacitor connection terminal for charge pump
13	CP1	
14	CP	
15	Sense 2	Overcurrent sense terminal
16,17	OB	Output terminal B
18	V _{BB}	Driver supply

Typical Connection Diagram

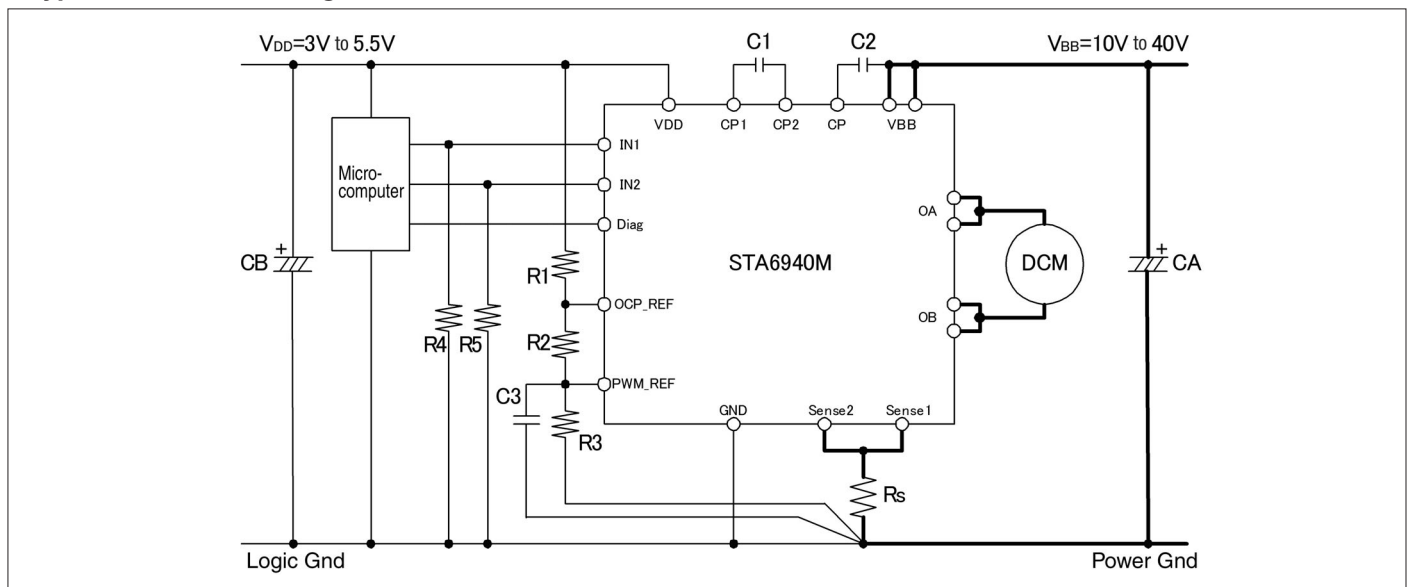

External Dimensions (ZIP18 [STA18Pin])

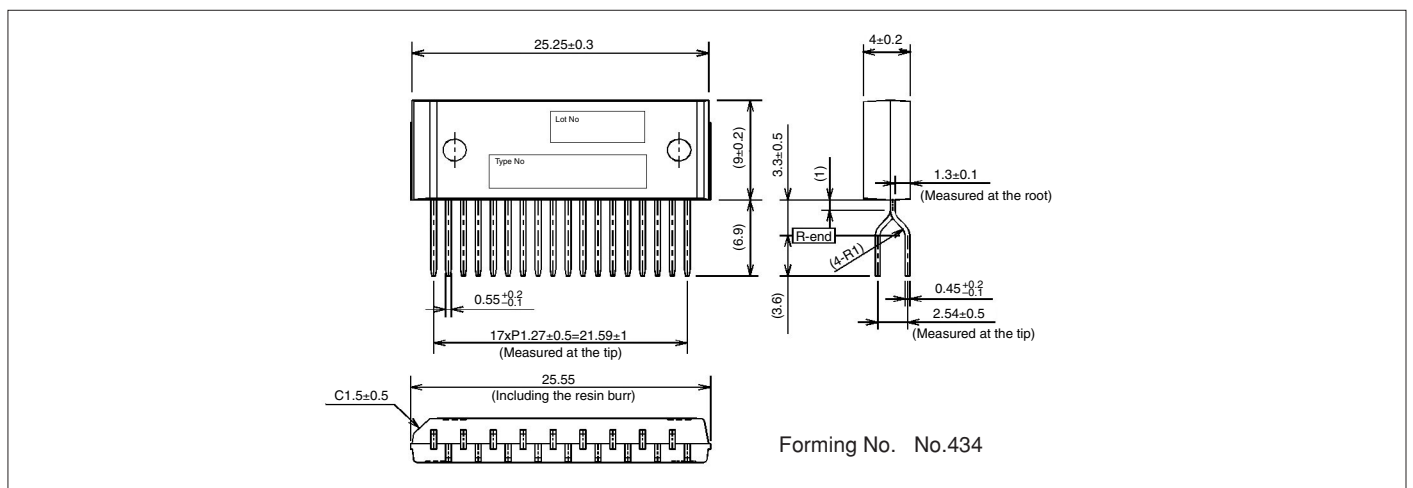

SPI-6631M

■ Features

- Power supply voltages, V_{BB} : 13 V to 33 V
- Signal power supply configuration
- Output current I_{out} : 3 A (max)... repetitive current (normal-operation current)
- Built-in current recirculation diode
- Built-in UVLO, TSD and OCP protection
- Built-in dead time function that prevents through current upon phase switching
- Built-in error sense flag output
- HSOP16-pin package

■ Absolute Maximum Ratings

Parameter	Symbol	Ratings	Unit	Conditions
Main Supply Voltage	V_{BB}	35	V	
MOSFET Output Breakdown Voltage	V_{DSS}	35	V	DutyCycle=100%*
Output Current	I_{out}	±3	A	
Input Voltage	V_{IN}	-0.3 to 6.5	V	
S Terminal Voltage	V_{SEN}	-2 to 2	V	
Alarm Terminal Voltage	V_{ALARM}	6.5	V	
Alarm Input Current	I_{ALARM}	1	mA	
Power Dissipation	P_D	2.6	W	When using a Sanken evaluation board
Junction Temperature	T_J	150	°C	
Storage Temperature	T_{STG}	-30 to 150	°C	
Operating Ambient Temperature	T_A	-20 to 85	°C	

*: Output current value may be limited, depending on the duty ratio, ambient temperature, and heating conditions. Do not exceed the rated current or maximum junction temperature ($T_J = 150^\circ\text{C}$).

■ Electrical Characteristics

($T_A=25^\circ\text{C}$, $V_{BB}=24\text{V}$, unless otherwise specified)

Parameter	Symbol	Ratings			Unit	Conditions
		min.	typ.	max.		
Main Supply Voltage	V_{BB}	13	–	33	V	In operation
Main Supply Current	I_{BB}	–	–	20	mA	
Maximum Clock Pulse Width	t_w	–	–	3	μs	
Input Voltage	V_{IL}	–	–	0.8	V	
	V_{IH}	2.0	–	–	V	
Input Current	I_{IL}	–	±8	–	μA	$V_{IN(0)}$, $V_{IN}=0.8\text{V}$
	I_{IH}	–	±20	–	μA	$V_{IN(1)}$, $V_{IN}=2.0\text{V}$
Crossover Dead Time	T_{delay}	100	500	1200	ns	
VB Terminal Breakdown Voltage	V_B	–	$V_{BB}+5$	–	V	Breakdown voltage between VB and GND
VB-OUT Breakdown Voltage	V_{B-OUT}	–	5	–	V	
VB Terminal Current	I_B	–	–	3	mA	$V_{B-OUT}=5\text{V}$
Output Leakage Current	I_{DSS}	–	–	800	μA	$V_{OUT}=V_{BB}=35\text{V}$
		-800	–	–	μA	$V_{OUT}=0\text{V}$
MOSFET ON Resistance	$R_{DS(ON)}$	–	0.4	0.7	Ω	$I_{out}=-1\text{A}$, Between V_{BB} and OUT $I_{out}=1\text{A}$, Between OUT and S
MOSFET Diode Forward Voltage	V_{SD}	–	–	2.2	V	$I_{SD}=1\text{A}$
Overcurrent Sense Current	I_{OCP}	7	–	–	A	Short between Out and Out
Overcurrent Protection Blank Time	t_{blank}	0.7	1.2	4	μs	
Overcurrent Protection Delay Time	t_{ocp}	0.5	1	2.2	ms	
Thermal Protection Operation Temperature	T_J	–	170	–	°C	
Thermal Protection Hysteresis	ΔT_J	–	15	–	°C	
Low Voltage Protection Operation Voltage	UVLO	4.0	4.5	5.0	V	V_{BB} voltage
Low Voltage Protection Hysteresis	ΔUVLO	0.4	0.45	0.5	V	
Alarm Output Voltage	V_{ALARM}	–	–	0.5	V	$I=1\text{mA}$

Internal Block Diagram

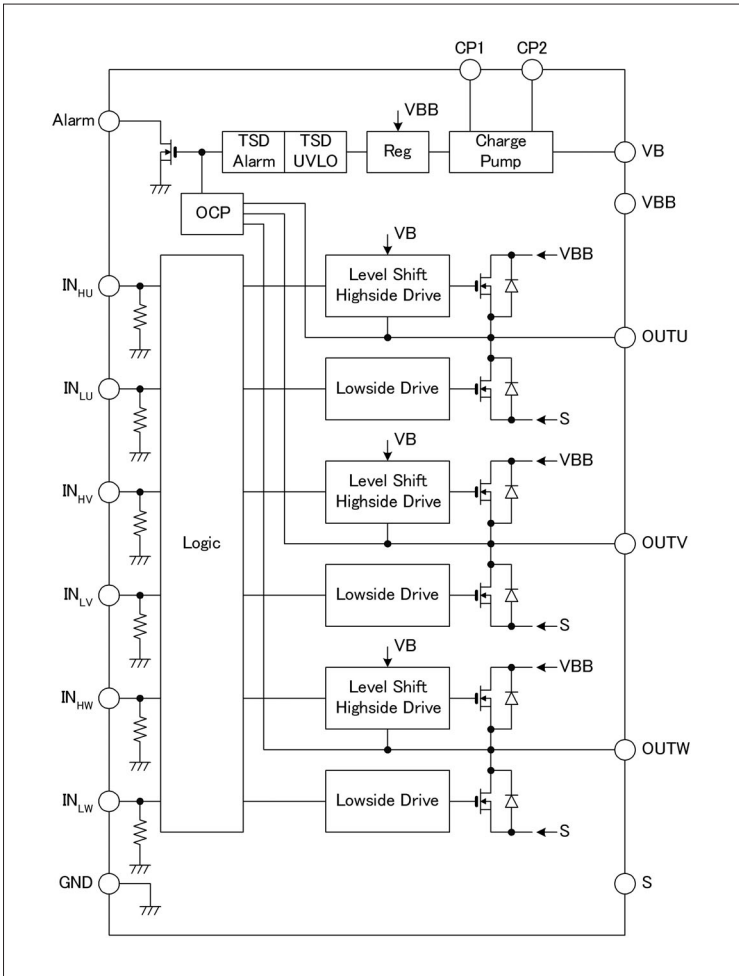

Pin Assignment

Pin No.	Symbol	Function
1	CP2	Capacitor terminal for charge pump 2
2	CP1	Capacitor terminal for charge pump 1
3	OUTU	DMOSFET phase U output
4	S	Sense terminal (lower arm source output)
5	OUTV	DMOSFET phase V output
6	OUTW	DMOSFET phase W output
7	Alarm	Alarm output
8	GND	Ground
9	IN _{LW}	Phase W lower arm input
10	IN _{HW}	Phase W upper arm input
11	IN _{LV}	Phase V lower arm input
12	IN _{HV}	Phase V upper arm input
13	VBB	Driver supply terminal
14	IN _{LU}	Phase U lower arm input
15	IN _{HU}	Phase U upper arm input
16	VB	Capacitor terminal for charging up charge pump

External Dimensions (HSOP16)

(Unit : mm)

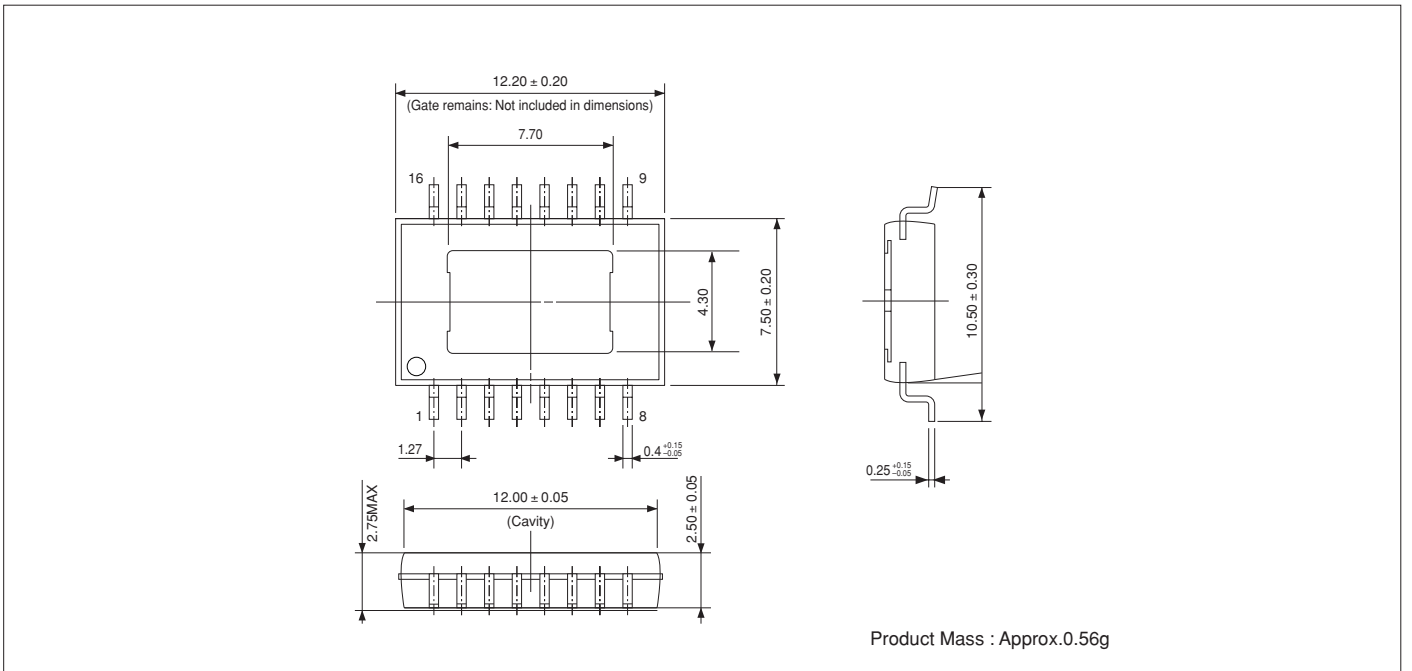

Product Mass : Approx.0.56g

SI-6633M

Features

- Built-in power element, normal operation rated output current $I_{out} = 2A$ (DC)/4A (peak)
- Hall element input
- Provides the following current control functions:
 - Peak current control fixed frequency PWM (internal PWM)
 - PWM control (external PWM) based on speed control signal (analog signal)
 - PWM control (logic PWM) based on logic input
- Protection functions
 - Overcurrent protection, overvoltage protection
 - Thermal protection, undervoltage lockout protection
 - Motor lock detection
- Provides alarm output pin for protection function operation
- Provides pin (FG) to output rotation signal generated by state transition of Hall input
- Built-in synchronous rectifier function that reduces power dissipation
- Built-in switching function for synchronous rectifier operation (Active/Passive)
- Standby mode

Absolute Maximum Ratings

($T_a=25^\circ\text{C}$)

Parameter	Symbol	Ratings	Unit	Conditions
Supply Voltage	V_{BB}	-0.3 to 38	V	
Output Voltage	V_{OUT}	V_{BB}	V	
Output Current*	$I_{OUT(Ave)}$	± 2	A	$t_w < 10\text{msec}$
	$I_{OUT(Peak)}$	± 4	A	
Logic Input Voltage	$V_{IN(Logic)}$	-0.3 to 5.5	V	
Analog Input Voltage	$V_{IN(Analog)}$	-0.3 to 6	V	
Detection Voltage	V_{SENSE}	± 0.5	V	
Package Power Dissipation	P_D	2.9	W	Sanken Evaluation Board
Maximum Junction Temperature	T_J	150	$^\circ\text{C}$	
Storage Temperature	T_{stg}	-40 to 150	$^\circ\text{C}$	
Operating Ambient Temperature	T_a	-20 to 85	$^\circ\text{C}$	

*: The output current value may be limited, depending on the duty ratio, ambient temperature, and heating conditions. Be sure to perform sufficient evaluation and verification by referring to the thermal design data and application notes so that other ratings will not be exceeded under any circumstances.

Recommended Operating Conditions

Parameter	Symbol	Ratings	Unit	Conditions
Supply Voltage	V_{BB}	10 to 30	V	During normal operation
Logic Input Voltage	$V_{IN(Logic)}$	0 to 5.5	V	
Analog Input Voltage	$V_{IN(Analog)}$	0 to 5.5	V	Excluding REF
REF Input Voltage	V_{Ref}	0.5 to 5.5	V	The control current precision degrades significantly at 0.5V or lower.
Detection Voltage	V_{SEN}	± 0.5	V	
Package Temperature	T_C	105	$^\circ\text{C}$	
Operating Ambient Temperature	T_a	-20 to 85	$^\circ\text{C}$	

Electrical Characteristics

($T_a=25^\circ\text{C}$, $V_{BB}=24\text{V}$, $V_{DD}=5\text{V}$, unless otherwise specified)

Parameter	Symbol	Ratings			Unit	Conditions
		min.	typ.	max.		
Driver Supply Voltage Range	V_{BB}	10	-	V_{BBov}	V	During motor driving
Charge Pump Output Voltage	V_{CP}	6	7.5	9	V	Output disabled, CP-VBB voltage
Charge Pump Oscillation Frequency	f_{CP}	90	120	150	kHz	
Main Supply Current	I_{BB}	5	10	15	mA	Output disabled
	I_{BBSTBY}	-	100	500	μA	$V_{STBY}=2.5\text{V}$
Output Pin Leakage Current	I_{OLKL}	-200	-100	-50	μA	$V_{BB}=38\text{V}$, $V_{OUT}=0\text{V}$
	I_{OLKH}	50	100	200	μA	$V_{BB}=V_{OUT}=38\text{V}$
Output MOSFET ON Resistance	$R_{DS(on)}$	0.1	0.2	0.3	Ω	$I_{DS}=2.0\text{A}$, S pin connected to GND
Output MOSFET Diode Forward Voltage	V_{SD}	0.8	1.1	1.4	V	$I_{SD}=2.0\text{A}$
STBY Pin Input Voltage	V_{STBYL}	0	-	0.8	V	
	V_{STBYH}	2.5	-	V_{DD}	V	
	ΔV_{STBY}	0.1	0.25	0.4	V	Hysteresis width
STBY Pin Input Current	I_{STBYL}	0	± 1	± 10	μA	
	I_{STBYH}	20	50	100	μA	$V_{STBY}=5\text{V}$
Logic Input Voltage	V_{INPL}	0	-	0.8	V	
	V_{INPH}	3.5	-	V_{DD}	V	
	ΔV_{INP}	1	1.5	2	V	Hysteresis width
Logic Input Current	I_{INPL}	0	± 1	± 10	μA	$V_{IN}=0\text{V}$
	I_{INPH}	0	± 1	± 10	μA	$V_{IN}=5.5\text{V}$
REF Pin Input Current	I_{REF}	-5	-0.5	1	μA	$V_{REF}=0$ to 5.5V
REF Pin Input Voltage Range	V_{REF}	0.5	-	5.5	V	
SEN Pin Input Current	I_{SEN}	0	± 2.5	± 10	μA	$V_{SEN}=0$ to 0.5V
Current Detection Voltage Ratio	V_{SEN}/V_{REF}	-10	-	10	%	$V_{REF}=5.5\text{V}$
Current Detection Filter Time	t_{LPFSEN}	0.6	1.8	3	μs	
CPWM Pin Threshold Voltage	V_{CPWML}	1.1	1.5	1.9	V	
	V_{CPWMH}	3	3.5	4	V	
CPWM Pin Oscillation Frequency	f_{CPWM}	15	25	35	kHz	$C_{PWM}=1000\text{pF}$
CLD Pin Oscillation Frequency	f_{CLD}	54	64	74	Hz	$C_{LD}=0.1\mu\text{F}$
AIN Pin Input Current	I_{AIN}	-1	-0.5	1	μA	AINP, AINN pin, $V_{AIN}=0$ to 5.5V
AOUT Pin Enable Threshold Voltage	V_{AOENA}	-	1.2	V_{CPWML}	V	When AOUT pin voltage rises
	$V_{AOENahys}$	0.05	0.1	0.15	V	Hysteresis width
AOUT Pin Maximum Output Voltage	V_{AOUTH}	V_{CPWMH}	4	4.45	V	During output PWM operation
AOUT Pin Externally Applied Voltage Range	V_{AOUTEI}	4.5	-	5.5	V	Output 100% ON
AOUT Pin Maximum Output Current	I_{AOUT}	7.5	-	-	mA	$V_{AOUT}=0\text{V}$
AOUT Pin Pull-down Resistance	R_{AOUT}	25	32.5	40	k Ω	$V_{AOUT}=2.5\text{V}$
Flag Output Pin ON Voltage	$V_{FLAG(ON)}$	0.1	0.2	0.5	V	$I_{FLAG}=2\text{mA}$
Flag Output Pin Leakage Current	$I_{FLAG(OFF)}$	0	-	20	μA	$V_{FLAG}=5.5\text{V}$
FG Output Pin ON Voltage	$V_{FG(ON)}$	0.1	0.2	0.5	V	$I_{FG}=2\text{mA}$
FG Output Pin Leakage Current	$I_{FG(OFF)}$	0	-	20	μA	$V_{FG}=5.5\text{V}$
VBB Low Voltage Protection Threshold Voltage	V_{BBUVH}	7	7.5	9	V	When V_{BB} voltage rises
	$V_{BBUVhys}$	0.1	0.3	0.5	V	Hysteresis width
Overvoltage Protection Starting Voltage	V_{BBOV}	34	35	37.5	V	When V_{BB} voltage rises
	$V_{BBOVhys}$	1.5	2	2.5	V	Hysteresis width
Overcurrent Detection Voltage	V_{OCPLS}	1	1.3	1.5	V	OUT-GND voltage, low side detection
	V_{OCPHS}	0.7	1	1.3	V	V_{BB} -OUT voltage, high side detection
Overcurrent Detection Filter Time	t_{LPFOC}	-	0.6	t_{LPFSEN}	μs	
Thermal Protection Operation Temperature	T_{TSD}	150	165	-	$^\circ\text{C}$	When temperature rises
	ΔT_{TSD}	-	50	-	$^\circ\text{C}$	Hysteresis width
Thermal Alarm Operation Temperature	T_{TA}	-	120	-	$^\circ\text{C}$	When temperature rises
	ΔT_{TA}	-	10	-	$^\circ\text{C}$	Hysteresis width
Propagation Delay Time between Input and Output	t_{PDON}	-	2.3	-	μs	HALL input \rightarrow Output ON
	$t_{PD OFF}$	-	2.1	-	μs	HALL input \rightarrow Output OFF
	$t_{PDPWMON}$	-	1.1	-	μs	PWM input \rightarrow Output ON
	$t_{PDPWMOFF}$	-	0.9	-	μs	PWM input \rightarrow Output OFF
OUT Pin Dead Time	t_{DEAD}	100	300	800	ns	
Hall Input Current	I_{HALL}	-2	-0.5	1	μA	$V_{IN}=0.2$ to 4.2V
Common Mode Input Voltage Range	V_{CMR}	0.2	-	3.5	V	
AC Input Voltage Range	V_{HALL}	60	-	-	mV	
Hysteresis	V_{HYS}	-	20	V_{HALL}	mV	Design assurance level
Pulse Removal Filter	t_{pulse}	1	2	3	μs	

*: Use typ. data for design. The direction in which current flows out of the device is regarded as negative.

Internal Block Diagram



External Dimensions (QFN36)



Pin Assignment Diagram



SI-6633C

Control IC

Features

- Drives 6-element N-channel MOSFET
- Supports Hall element input
- Provides the following current control functions:
 - Peak current control fixed frequency PWM (internal PWM)
 - PWM control (logic PWM) based on logic input
- Protection functions
 - Overcurrent protection, overvoltage protection
 - Thermal protection, undervoltage lockout protection
 - Motor lock detection
- Provides alarm output pin for protection function operation
- Provides pin (FG) to output rotation signal generated by state transition of Hall input
- Built-in synchronous rectifier function that reduces power dissipation
- Built-in switching function for synchronous rectifier operation (Active/Passive)
- Standby mode

Absolute Maximum Ratings

Parameter	Symbol	Ratings	Unit	Conditions
Supply Voltage	V _{BB}	-0.3 to 38	V	
Output Voltage	V _{OUT}	-1 to 38	V	
Logic Input Voltage	V _{IN(Logic)}	-0.3 to 6	V	
Hall Input Voltage	V _{HALL}	-0.3 to 6	V	
REF Input Voltage	V _{Ref}	-0.3 to 6	V	
Detection Voltage	V _{SENSE}	±0.5	V	
Maximum Junction Temperature	T _{j(max)}	150	°C	
Storage Temperature	T _{stg}	-40 to 150	°C	
Operating Ambient Temperature	T _a	-20 to 85	°C	
Package Thermal Resistance	R _{θja}	43	°C/W	With Sanken Evaluation Board (2-layer board; 60mm×77mm)

Recommended Operating Conditions

Parameter	Symbol	Ratings	Unit	Conditions
Supply Voltage	V _{BB}	10 to 30	V	
Control Supply Voltage	V _{DD}	3 to 5.5	V	
Logic Input Voltage	V _{IN(Logic)}	0 to 5.5	V	
REF Input Voltage	V _{Ref}	0.5 to 5.5	V	The control current precision degrades significantly at 0.5V or lower.
Hall Input Voltage	V _{HALL}	0.2 to 4	V	
Detection Voltage	V _{SENSE}	±0.5	V	
Package Temperature	T _c	105	°C	
Operating Ambient Temperature	T _a	-20 to 85	°C	

Electrical Characteristics

(T_a=25°C, V_{BB}=24V, V_{DD}=5V, unless otherwise specified)

Parameter	Symbol	Ratings			Unit	Conditions
		min.	typ.	max.		
Output Drivers						
V _{BB} Voltage Range	V _{BB}	10	-	V _{BBov}	V	During operation
Main Supply Current	I _{BB}		10	20	mA	Operating (output is OFF)
		50	-	200	μA	Standby mode
Control Logic						
V _{DD} Voltage Range	V _{DD}	3	-	5.5	V	During operation
V _{DD} Pin Current	I _{DD}		0.5	3	mA	Operating (output is OFF)
		100	180	500	μA	Standby mode
Logic Input Voltage	V _{IN(0)}	0	-	V _{DD} ×0.25	V	
	V _{IN(1)}	V _{DD} ×0.75	-	V _{DD}	V	
Logic Input Current	I _{IN(0)}	-1	-	1	μA	V _{IN(0)} , V _{IN} =0V
	I _{IN(1)}	-1	-	1	μA	V _{IN(1)} , V _{IN} =5V
Input Pin Filter	t _{LOGIC}	0.3	0.5	0.95	μs	f _{in} =50kHz, Duty=50%
Maximum Response Frequency	f _{PWM}	(100)	-	-	kHz	PWM pin, Duty=50%
COSC Pin Oscillation Frequency	f _{OSC}	19	25	32	KHz	C _{OSC} =330pF
Gate Drive						
High Side Output Voltage	V _{GS(H)}	6	-	9	V	I _{GATE} =2mA For V _{BB} . I _{GATE} =2mA
Low Side Output Voltage	V _{GS(L)}	6	-	9	V	I _{GATE} =2mA
Drive Current	I _{GATE}	20	30	60	mA	GH=GL=4V, V _{CP} =V _{BB} +TBD
Dead Time	t _{dead}		1000		ns	
Internal PWM						
REF Pin Input Current	I _{ref}	-5	-0.1	1	μA	
REF Pin Input Voltage Range	V _{Ref}	0.5	-	5.5	V	
SEN Pin Input Current	I _{Sen}	-5	-0.1	1	μA	V _{Sen} =0 to 1V
Detection Voltage	V _{Sen}	V _{REF} ×0.095	V _{REF} ×0.1	V _{REF} ×0.12	V	V _{Ref} =1 to 5V
Current Detection Filter Time	t _{LPFSen}	1	2	4	μs	Design assurance level
Protection						
FL Output Saturation Voltage	V _{FI(ON)}	0.2	0.4	0.7	V	I _{FG} =2mA
FL Output Pin ON Current	I _{FI(ON)}	5	7.5	15	mA	V _{FI} =2V
FL Output Leakage Current	I _{FI(OFF)}	0	-	50	μA	V _{FG} =5.5V
Overcurrent Detection Voltage	V _{OCP}	1.4	1.5	1.65	V	Low-side MOSFET detection (between OUT and GND)
Overcurrent Detection Filter Time	t _{FLT OCP}	0.75	1.5	3	μs	Design assurance level
OCP Output OFF Timer Count	N _{OCP_OFF}	256	256	256		
V _{BB} Overvoltage Protection Threshold Voltage	V _{BBov}	33	35	37	V	
V _{BB} Overvoltage Protection Hysteresis	V _{BBovhys}	1.25	2	3.5	V	
CLD Pin Oscillation Frequency	f _{LD}	100	128	164	Hz	C _{LD} =0.1μF
Lock Detection Timer Count	N _{LD}	256	256	256		
Thermal Protection Operation Temperature	T _{JTSD}	151	170	185	°C	When temperature rises, design assurance level
Thermal Protection Hysteresis	T _{JTSDhys}	10	15	20	°C	
V _{DD} Low Voltage Protection Release Voltage	V _{DDUV}	2.65	2.8	2.95	V	When V _{DD} voltage rises
V _{DD} Low Voltage Protection Hysteresis	V _{DDUVhys}	0.1	0.15	0.25	V	
V _{BB} Low Voltage Protection Release Voltage	V _{BBUV}	9	9	9.9	V	When V _{BB} voltage rises
V _{BB} Low Voltage Protection Hysteresis	V _{BBUVhys}		0.3		V	
FG						
FG Output Saturation Voltage	V _{FG(sat)}	0.2	0.4	0.7	V	I _{FG} =2mA
FG Output Leakage Current	I _{FGlk}	0	-	50	μA	V _{FG} =5.5V
Hall Logic						
Hall Input Current	I _{HALL}	-5	-0.1	1	μA	V _{IN} =0.2 to 4V
Common Mode Input Voltage Range	V _{CMR}	0.2	-	4	V	
AC Input Voltage Range	V _{HALL}	60	-	-	mV _{p-p}	
Hysteresis	V _{HYS}	25	40	V _{HALL}	mV	Design assurance level
Pulse Removal Filter	t _{pulse}	1	2	4	μs	

*: Use typ. data for design. The direction in which current flows out of the device is regarded as negative.

Internal Block Diagram



External Dimensions (QFN36)

(Unit : mm)



Pin Assignment Diagram



SX6800MH Series Surface-Mount, Built-in Overcurrent Protection, Thermal Shutdown, and Overcurrent Limiting Circuits

Features

- A package of 6 MOSFET units for 3-phase bridge and pre-drive (HVIC, LVIC)
- Best for driving the fan motor (built-in motor) of air conditioner, etc.
- Built-in boot diode with limited resistance
- Built-in undervoltage lock out (UVLO) circuit
- Built-in overcurrent protection circuit (OCP)
- Built-in Thermal Shut Down (TSD) function
- Built-in current limiter function (OCL)
- Error (FO) terminal with shutdown input function
- 7.5V regulator output function (35mA max.)

Absolute Maximum Ratings

(T_a=25°C)

Parameter	Symbol	Ratings			Unit	Conditions
		SX68001MH	SX68002MH	SX68003MH		
MOSFET Output Breakdown Voltage	V _{DSS}	250	500	500	V	V _{CC} =15V, V _{IN} =0V
Control Supply Voltage	V _{CC}	20	20	20	V	Between V _{CC} and COM
Control Supply Voltage (Bootstrap)	V _{BS}	20	20	20	V	Between V _B and HS (U, V, W)
Output Current (continuous)	I _O	2.0	1.5	2.5	A	
Output Current (pulse)	I _{OP}	3.0	2.25	3.75	A	PW≤100μs, duty=1%
Input Voltage	V _{IN}	-0.5 to +7	-0.5 to +7	-0.5 to +7	V	
Thermal Resistance (Junction to Case)	θ _{J-C}	15	15	15	°C/W	*1
Thermal Resistance (Junction to Ambient Air)	θ _{J-A}	41.7	41.7	41.7	°C/W	*1
Operating Case Temperature	T _{OP}	-20 to +100	-20 to +100	-20 to +100	°C	
Junction Temperature (Power part)	T _{CH}	+150	+150	+150	°C	
Storage Temperature	T _{STG}	-40 to +150	-40 to +150	-40 to +150	°C	

*1: When mounted on a board (1.6 mm, 35μm copper layer, CEM-3, moldless, natural air cooling)

Recommended Operating Conditions

Parameter	Symbol	Ratings						Unit	Conditions			
		SX68001MH			SX68002MH					SX68003MH		
		min.	typ.	max.	min.	typ.	max.	min.	typ.	max.		
Main Supply Voltage	V _{BS}	-	150	200	-	300	400	-	300	400	V	Between V _{BS} and LS
Control Supply Voltage	V _{CC}	13.5	-	16.5	13.5	-	16.5	13.5	-	16.5	V	Between V _{CC} and COM
Input Signal Dead Time	t _{dead}	1.5	-	-	1.5	-	-	1.5	-	-	μs	
Minimum Input Pulse Width	t _w	0.5	-	-	0.5	-	-	0.5	-	-	μs	

Electrical Characteristics

(T_a=25°C)

Parameter	Symbol	Ratings									Unit	Conditions
		SX68001MH			SX68002MH			SX68003MH				
		min.	typ.	max.	min.	typ.	max.	min.	typ.	max.		
Control Supply Current	I _{CC}	-	4.6	8.5	-	4.6	8.5	-	4.6	8.5	mA	V _{CC1,2} =15V, I _{REG} =0A
Boot Supply Current	I _{BS}	-	140	400	-	140	400	-	140	400	μA	V _B *HS=15V, H _{IN} =5V, per phase, T _C =20°C to 125°C
Input Voltage	V _{IH}	-	2.0	2.5	-	2.0	2.5	-	2.0	2.5	V	V _{CC} =15V, Output:ON
	V _{IL}	1.0	1.5	-	1.0	1.5	-	1.0	1.5	-	V	V _{CC} =15V, Output:OFF
Input Voltage Hysteresis Width	V _H	-	0.5	-	-	0.5	-	-	0.5	-	V	V _{CC} =15V
Input Current	I _{ih}	-	230	500	-	230	500	-	230	500	μA	V _{CC} =15V, V _{IN} =5V
Undervoltage Lock Out (high side)	U _{VHL}	9.0	-	11.0	9.0	-	11.0	9.0	-	11.0	V	Between V _{BS} and U(V, W)
	U _{VHH}	9.5	-	11.5	9.5	-	11.5	9.5	-	11.5	V	Between V _{BS} and U(V, W)
Undervoltage Lock Out (low side)	U _{VLL}	10.0	-	12.0	10.0	-	12.0	10.0	-	12.0	V	Between V _{CC} and COM
	U _{VLLH}	10.5	-	12.5	10.5	-	12.5	10.5	-	12.5	V	Between V _{CC} and COM
FO Terminal Output Voltage	V _{FOL}	-	-	0.5	-	-	0.5	-	-	0.5	V	V _{CC} =15V, V _{FO} =5V, R _{FO} =10kΩ
	V _{FOH}	4.8	-	-	4.8	-	-	4.8	-	-	V	V _{CC} =15V, V _{FO} =5V, R _{FO} =10kΩ
OCL Output Voltage	V _{OCLL}	-	-	0.5	-	-	0.5	-	-	0.5	V	V _{CC} =15V
	V _{OCLH}	4.5	-	5.5	4.5	-	5.5	4.5	-	5.5	V	V _{CC} =15V
Current Limiter Reference Voltage	V _{LIM}	0.6175	0.65	0.6825	0.6175	0.65	0.6825	0.6175	0.65	0.6825	V	V _{CC} =15V
Overcurrent Protection Trip Voltage	V _{TRIP}	0.9	1.0	1.1	0.9	1.0	1.1	0.9	1.0	1.1	V	V _{CC} =15V
Overcurrent Protection Retention Time	t _p	20	25	-	20	25	-	20	25	-	μs	V _{CC} =15V
OCP Blanking Time	t _{bk(ocp)}	-	2	-	-	2	-	-	2	-	μs	V _{CC} =15V
SD Terminal Blanking Time	t _{bk(ocl)}	-	3.3	-	-	3.3	-	-	3.3	-	μs	V _{CC} =15V
Thermal Protection and Release Threshold	T _{DH}	135	150	165	135	150	165	135	150	165	°C	V _{CC} =15V
	T _{DL}	105	120	135	105	120	135	105	120	135	°C	V _{CC} =15V
	T _{Dhys}	-	30	-	-	30	-	-	30	-	°C	V _{CC} =15V
Regulator Output Voltage	V _{REG}	6.75	7.5	8.25	6.75	7.5	8.25	6.75	7.5	8.25	V	I _{REG} =35mA
MOSFET Output Breakdown Voltage	V _{DSS}	250	-	-	500	-	-	500	-	-	V	V _{CC} =15V, I _D =100μA, V _{IN} =0V
MOSFET Output Leakage Current	I _{DSS}	-	-	100	-	-	100	-	-	100	μA	V _{CC} =15V, V _{DSS} =500V (250 V for SX68001MH), V _{IN} =0V
MOSFET DC ON Resistance	R _{DS(on)}	-	1.25	1.5	-	3.2	4.0	-	2.0	2.4	Ω	V _{CC} =15V, I _D =1A(0.75 A for SX68002MH or 1.25 A for SX68003MH), V _{IN} =5V
Diode Forward Voltage	V _{SD}	-	1.1	1.5	-	1.0	1.5	-	1.0	1.5	V	V _{CC} =15V, I _{SD} =1A(0.75 A for SX68002MH or 1.25 A for SX68003MH), V _{IN} =0V
Boot Diode Leakage Current	I _{IB}	-	-	10	-	-	10	-	-	10	μA	V _R =500V(250 V for SX68001MH)
Boot Diode Forward Voltage	V _{FB}	-	1.0	1.3	-	1.0	1.3	-	1.0	1.3	V	I _F =0.15A
Boot Diode Series Resistance	R _{BD}	-	60	-	-	60	-	-	60	-	Ω	
High Side Switching Time	td(on)	-	800	-	-	810	-	-	940	-	ns	V _{CC} =300V(150V for SX68001MH), V _{CC} =15V, I _D =1A(0.75 A for SX68002MH or 1.25 A for SX68003MH), V _{IN} =0 to 5V, Inductive load
	tr	-	45	-	-	60	-	-	100	-	ns	
	trr	-	75	-	-	120	-	-	135	-	ns	
	td(off)	-	720	-	-	815	-	-	975	-	ns	
	tf	-	40	-	-	40	-	-	45	-	ns	
Low Side Switching Time	td(on)	-	750	-	-	760	-	-	900	-	ns	
	tr	-	50	-	-	60	-	-	105	-	ns	
	trr	-	70	-	-	110	-	-	135	-	ns	
	td(off)	-	660	-	-	750	-	-	905	-	ns	
	tf	-	20	-	-	30	-	-	35	-	ns	

Internal Block Diagram

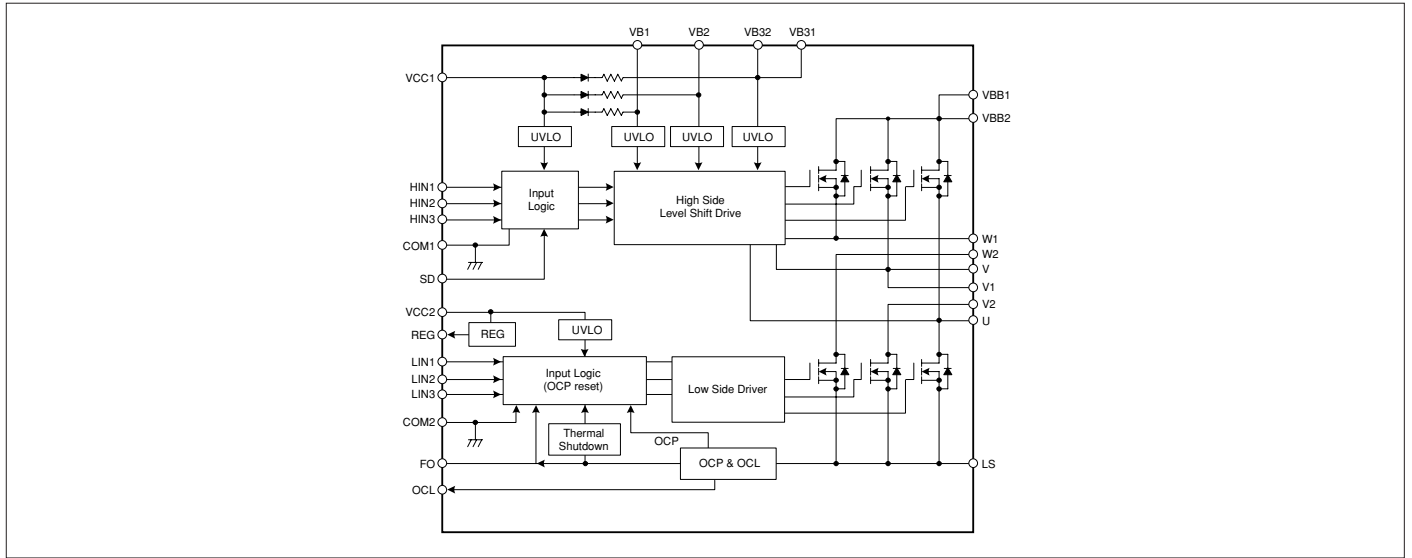

Typical Connection Diagram

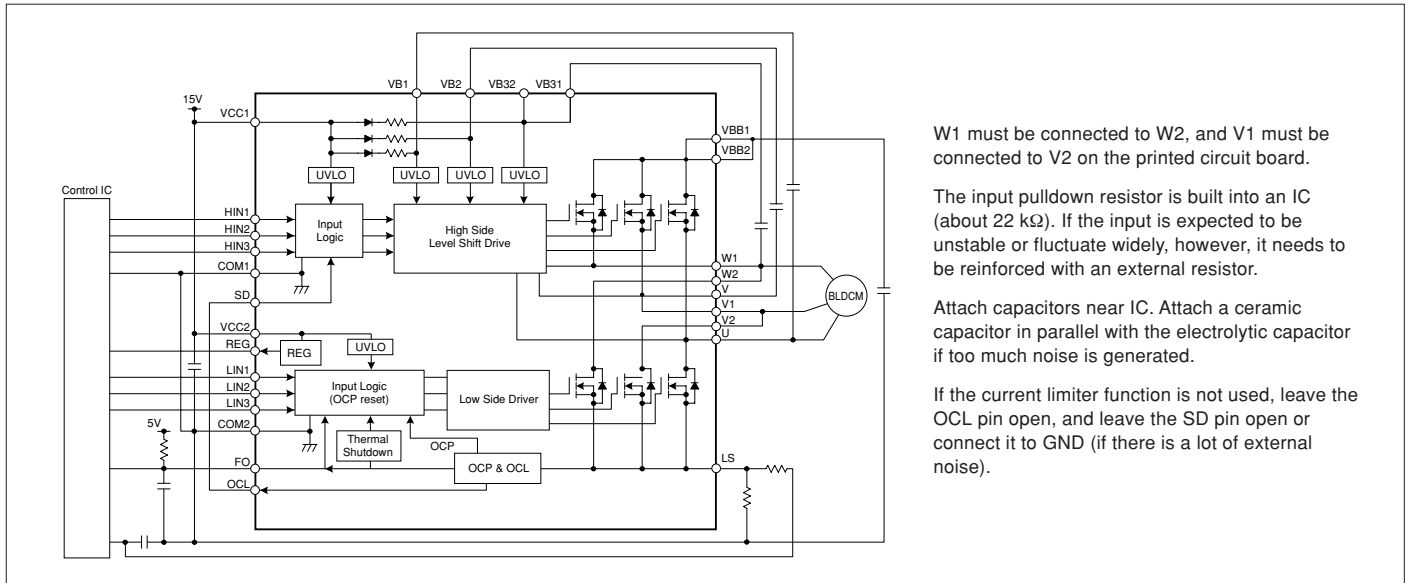

External Dimensions (SOP27)

(Unit : mm)

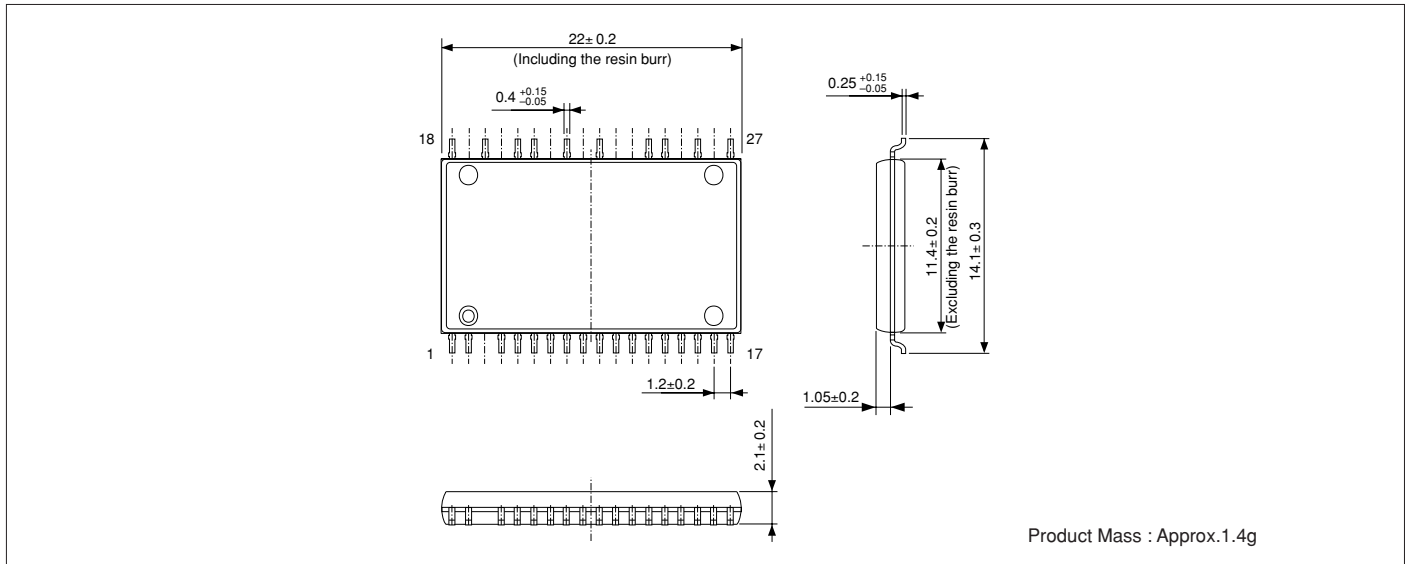

SMA6820MH Series Built-in Thermal detection and 7.5 V Regulator

Features

- A package of 6 MOSFET units for 3-phase bridge, pre-drive (HVIC, LVIC) and boot diode
- Best for fan motor inverter control
- High side drive of bootstrap method has been employed.
- Built-in undervoltage lock out (auto regression)
- Built-in Thermal detection circuit (no stopping)
- Built-in fail signal output function (for when the overheat detection circuit and UVLO)
- Built-in 7.5 V regulator output (35 mA, max.)
- Supports CMOS (3.3 and 5.0 V) input levels

Absolute Maximum Ratings

(Ta=25°C)

Parameter	Symbol	Ratings			Unit	Conditions
		SMA6821MH	SMA6822MH	SMA6823MH		
MOSFET Output Breakdown Voltage	VDSS	250	500	500	V	Vcc=15V, VIN=0V
Control Supply Voltage	Vcc	20	20	20	V	Between Vcc and COM
Control Supply Voltage (Bootstrap)	Vbs	20	20	20	V	Between VB and HS (U, V, W)
Output Current (continuous)	Io	2.0	1.5	2.5	A	
Output Current (pulse)	Iop	3	2.25	3.75	A	PW 100µs, duty=1%
Regulator Output Current	IREG	35	35	35	mA	
Input Voltage	VIN	-0.5 to +7	-0.5 to +7	-0.5 to +7	V	
Thermal Resistance (Junction to Case)	θj-c	4.46	4.46	4.46	°C/W	When all elements operating
Thermal Resistance (Junction to Ambient Air)	θj-a	31.25	31.25	31.25	°C/W	When all elements operating
Operating Case Temperature	Top	-20 to +100	-20 to +100	-20 to +100	°C	
Junction Temperature (Power part)	Tch	+150	+150	+150	°C	
Storage Temperature	Tstg	-40 to +150	-40 to +150	-40 to +150	°C	

Recommended Operating Conditions

Parameter	Symbol	Ratings									Unit	Conditions
		SMA6821MH			SMA6822MH			SMA6823MH				
		min.	typ.	max.	min.	typ.	max.	min.	typ.	max.		
Main Supply Voltage	VBS	-	140	200	-	300	400	-	300	400	V	Between VBS and LS
Control Supply Voltage	VCC	13.5	-	16.5	13.5	-	16.5	13.5	-	16.5	V	Between VCC and COM
Input Signal Dead Time	tdead	1.5	-	-	1.5	-	-	1.5	-	-	µs	
Minimum Input Pulse Width	tw	0.5	-	-	0.5	-	-	0.5	-	-	µs	

Electrical Characteristics

(Ta=25°C)

Parameter	Symbol	Ratings									Unit	Conditions
		SMA6821MH			SMA6822MH			SMA6823MH				
		min.	typ.	max.	min.	typ.	max.	min.	typ.	max.		
Control Supply Current	Icc	-	4	6	-	4	6	-	4	6	mA	Vcc=15V
Input Voltage	Vih	-	2	2.5	-	2	2.5	-	2	2.5	V	Vcc=15V, Output:ON
	Vil	1	1.5	-	1	1.5	-	1	1.5	-		Vcc=15V, Output:OFF
Input Current	Iih	-	50	100	-	50	100	-	50	100	µA	Vcc=15V, VIN=5V
	Iil	-	-	2	-	-	2	-	-	2		Vcc=15V, VIN=0V
Undervoltage Lock Out (high side)	UVHL	9.0	10.0	11.0	9.0	10.0	11.0	9.0	10.0	11.0	V	Between VB and U (V, W)
	UVHH	9.5	10.5	11.5	9.5	10.5	11.5	9.5	10.5	11.5		
Undervoltage Lock Out (low side)	UVLL	10.0	11.0	12.0	10.0	11.0	12.0	10.0	11.0	12.0	V	Between VCC and COM
	UVLH	10.5	11.5	12.5	10.5	11.5	12.5	10.5	11.5	12.5		
FO Pin Output Voltage	VFOH	0	-	1.0	0	-	1.0	0	-	1.0	V	Vcc=15V
	VFOH	4.0	-	5.5	4.0	-	5.5	4.0	-	5.5		
Overheat detection threshold	TDH	135	150	165	135	150	165	135	150	165	°C	Vcc=15V
Overheat detection release threshold	TDL	105	120	135	105	120	135	105	120	135	°C	Vcc=15V
Regulator output voltage	VREG	-	7.5	-	-	7.5	-	-	7.5	-	V	IREG=35mA
Boot Diode Forward Voltage	VFB	-	1.1	1.3	-	1.1	1.3	-	1.1	1.3	V	If=0.15A
Boot Diode Series Resistance	RBD	-	22	-	-	22	-	-	22	-	Ω	
MOSFET Output Breakdown Voltage	Voss	250	-	-	500	-	-	500	-	-	V	Vcc=15V, Id=100µA, VIN=0V
MOSFET Output Leakage Current	Ioss	-	-	100	-	-	100	-	-	100	µA	Vcc=15V, Vbs=500V (250V for SMA6821MH), VIN=0V
MOSFET DC On Resistance	Rds(ON)	-	1.25	1.5	-	3.6	4.0	-	2.0	2.4	Ω	Vcc=15V, Id=1.0A (0.75A for SMA6822MH, 1.25A for SMA6823MH), VIN=5V
Diode Forward Voltage	VSD	-	1.1	1.5	-	1.1	1.5	-	1.1	1.5	V	Vcc=15V, IsD=1.0A (0.75A for SMA6822MH, 1.25A for SMA6823MH), VIN=0V
High Side Switching Time	td(on)	-	430	-	-	485	-	-	665	-	ns	VBS=300V (150V for SMA6821MH), VCC=15V, Id=1A (0.75A for SMA6822MH, 1.25A for SMA6823MH), 0V≤VIN≤5V Inductive load
	tr	-	55	-	-	85	-	-	145	-		
	trr	-	90	-	-	120	-	-	150	-		
	td(off)	-	355	-	-	420	-	-	545	-		
	tf	-	20	-	-	30	-	-	40	-		
Low Side Switching Time	td(on)	-	405	-	-	520	-	-	720	-	ns	
	tr	-	60	-	-	100	-	-	175	-		
	trr	-	90	-	-	120	-	-	150	-		
	td(off)	-	395	-	-	485	-	-	605	-		
	tf	-	20	-	-	25	-	-	45	-		

Internal Block Diagram

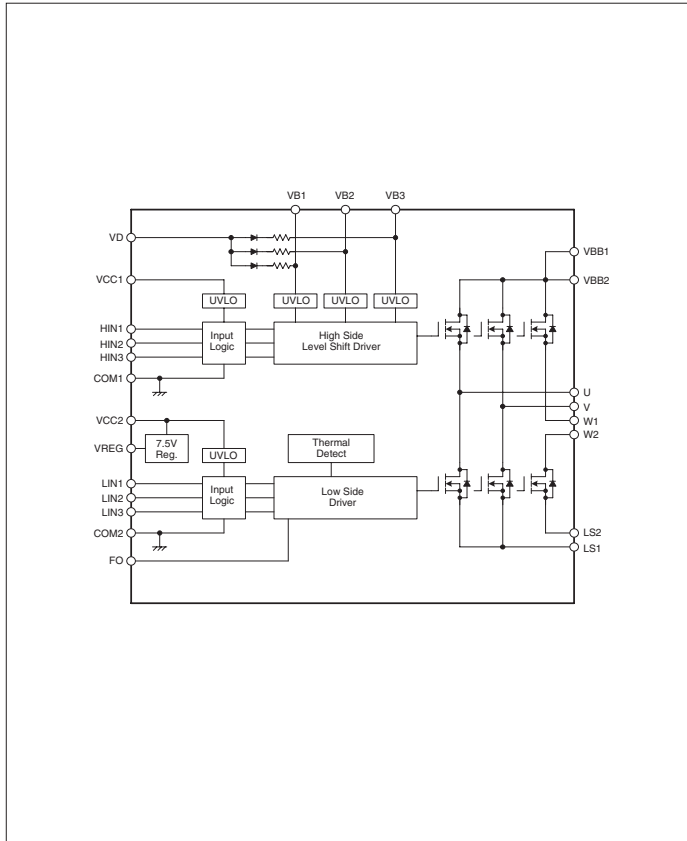

Typical Connection Diagram

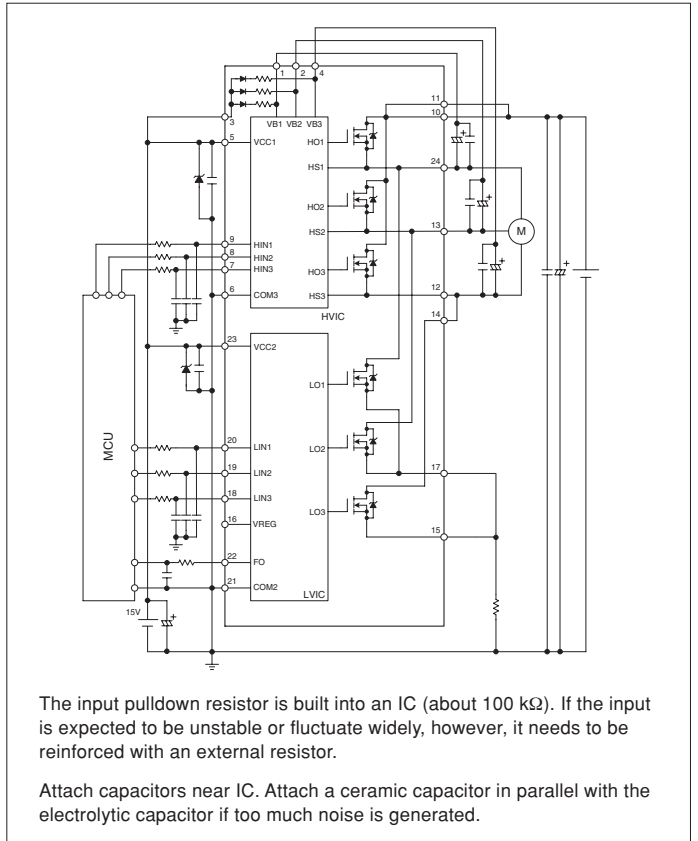

The input pull-down resistor is built into an IC (about 100 kΩ). If the input is expected to be unstable or fluctuate widely, however, it needs to be reinforced with an external resistor.

Attach capacitors near IC. Attach a ceramic capacitor in parallel with the electrolytic capacitor if too much noise is generated.

External Dimensions (ZIP24 [SMA24Pin])

(Unit : mm)

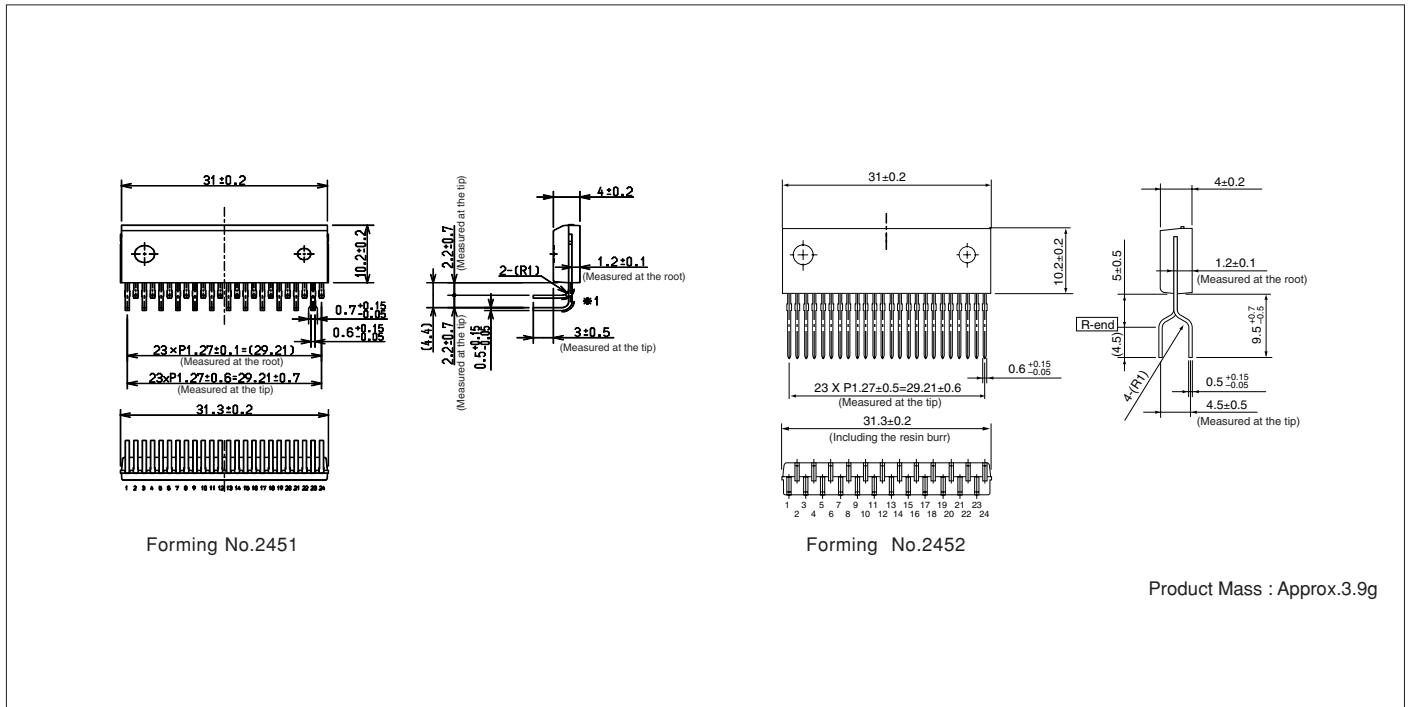

Forming No.2451

Forming No.2452

Product Mass : Approx.3.9g

SMA6860MZ Series

Built-in Overcurrent Protection, Thermal Shutdown, and Overcurrent Limiting Circuits

Features

- Built-in boot diode with 210Ω limiting resistor
- Built-in overcurrent protection circuit (OCP)
- Overcurrent protection with off-time period adjustable by an external capacitor
- Overcurrent limiting operation
- Built-in thermal shutdown (TSD) circuit
- Externally controllable shutdown operation

Absolute Maximum Ratings

(T_a=25°C)

Parameter	Symbol	Ratings			Unit	Conditions
		SMA6862MZ	SMA6863MZ	SMA6865MZ		
MOSFET Output Breakdown Voltage	V _{DSS}	500			V	V _{CC} =15V, I _D =100μA, V _{IN} =0V
Control Supply Voltage (V _{CC})	V _{CC}	20			V	Between V _{CC} and COM
Control Supply Voltage (Bootstrap)	V _{BS}	20			V	Between V _B and HS (U, V, W)
Output Current (continuous)	I _O	1.5	2.5	2.5	A	
Output Current (pulse)	I _{OP}	2.25	3.75	3.75	A	PW≤100μs, duty=1%
Input Voltage	V _{IN}	-0.5 to +7			V	H _{IN1} to H _{IN3} , L _{IN1} to L _{IN3}
Thermal Resistance (Junction to Case)	θ _{J-C}	4.46			°C/W	All elements operating
Thermal Resistance (Junction to Ambient Air)	θ _{J-A}	31.25			°C/W	All elements operating
Operating Case Temperature	T _C	-20 to +100			°C	
Junction Temperature (Power part)	T _J	150			°C	
Storage Temperature	T _{STG}	-40 to +150			°C	

Recommended Operating Conditions

Parameter	Symbol	Ratings									Unit	Conditions
		SMA6862MZ			SMA6863MZ			SMA6865MZ				
		min.	typ.	max.	min.	typ.	max.	min.	typ.	max.		
Main Supply Voltage	V _{BB}	-	300	400	-	300	400	-	300	400	V	Between V _{BB} and LS
Control Supply Voltage	V _{CC}	13.5	-	16.5	13.5	-	16.5	13.5	-	16.5	V	Between V _{CC} and COM
RC Pull-up Resistor	RR	33	-	390	33	-	390	33	-	390	kΩ	V _{RC} =5V
RC Noise Eliminating Capacitor	CC	1	-	4.7	1	-	4.7	1	-	4.7	nF	V _{RC} =5V
SD1 Pull-up Resistor	RL	3.3	-	10	3.3	-	10	3.3	-	10	kΩ	V _L =5V
SD1 Noise Eliminating Capacitor	CL	1	-	10	1	-	10	1	-	10	nF	V _L =5V
SD2 Pull-up Resistor	R _{UP2}	3.3	-	10	3.3	-	10	3.3	-	10	kΩ	V _{UP2} =5V
SD2 Noise Eliminating Capacitor	C _{SD2}	1	-	10	1	-	10	1	-	10	nF	V _{UP2} =5V
Input Signal Dead Time	t _{DEAD}	1.5	-	-	1.5	-	-	1.5	-	-	μs	T _J =-20°C to +150°C
Minimum Input Pulse Width	T _w	0.5	-	-	0.5	-	-	0.5	-	-	μs	

Electrical Characteristics

(T_a=25°C)

Parameter	Symbol	Ratings									Unit	Conditions
		SMA6862MZ			SMA6863MZ			SMA6865MZ				
		min.	typ.	max.	min.	typ.	max.	min.	typ.	max.		
Control Supply Current	I _{CC}	-	4.2	7	-	4.2	7	-	4.2	7	mA	V _{CC} =15V
Boot Supply Current	I _B	-	135	380	-	135	380	-	135	380	μA	V _B =15V, H _{IN} =5V
Input Voltage	V _{IH}	-	2.9	3.4	-	2.9	3.4	-	2.9	3.4	V	V _{CC} =15V
	V _{IL}	1.6	2.1	-	1.6	2.1	-	1.6	2.1	-	V	V _{CC} =15V
Undervoltage Lock Out	UV _{HL}	9.0	10.0	11.0	9.0	10.0	11.0	9.0	10.0	11.0	V	Between V _B and U (V, W)
	UV _{HH}	9.5	10.5	11.5	9.5	10.5	11.5	9.5	10.5	11.5	V	Between V _{CC} and COM
Undervoltage Lock Out	UV _{LL}	10.0	11.0	12.0	10.0	11.0	12.0	10.0	11.0	12.0	V	Between V _{CC} and COM
	UV _{LH}	10.5	11.5	12.5	10.5	11.5	12.5	10.5	11.5	12.5	V	Between V _{CC} and COM
Thermal Protection and Release Threshold	T _{DH}	120	135	150	120	135	150	120	135	150	°C	V _{CC} =15V
	T _{DL}	100	115	130	100	115	130	100	115	130	°C	V _{CC} =15V
Overcurrent Protection Trip Voltage	V _{TRIP}	-	1.0	-	-	1.0	-	-	1.0	-	V	V _{CC} =15V
Current Limiting Reference Voltage	V _{LIM}	-	0.53	-	-	0.53	-	-	0.53	-	V	V _{CC} =15V
Overcurrent Protection Retention Time	t _P	-	2	-	-	2	-	-	2	-	ms	V _{RC} =5V, RR=360kΩ, CC=0.0047μF
Boot Diode Leakage Current	I _{LBD}	-	-	10	-	-	10	-	-	10	μA	V _R =500V
Boot Diode Forward Voltage	V _{FB}	-	0.8	1.3	-	0.8	1.3	-	0.8	1.3	V	I _F =0.05A
Boot Diode Series Resistance	R _{SD}	-	210	-	-	210	-	-	210	-	Ω	
MOSFET Output Breakdown Voltage	V _{DSS}	500	-	-	500	-	-	500	-	-	V	V _{CC} =15V, I _D =100μA, V _{IN} =0V
MOSFET Output Leakage Current	I _{DSS}	-	-	100	-	-	100	-	-	100	μA	V _{CC} =15V, V _{DS} =500V, V _{IN} =0V
MOSFET DC ON Resistance	R _{DS(ON)}	-	3.6	4.0	-	2.0	2.4	-	1.4	1.7	Ω	V _{CC} =15V, I _D =1.25A (0.75A for the SMA6862MZ), V _{IN} =5V
MOSFET Diode Forward Voltage	V _{SD}	-	1.1	1.5	-	1.1	1.5	-	1.0	1.5	V	V _{CC} =15V, I _{SD} =1.25A (0.75A for the SMA6862MZ), V _{IN} =0V
High Side Switching Time	td(on)	-	720	-	-	820	-	-	750	-	ns	V _{BB} =300V, V _{CC} =15V, I _D =1.5A (2.5A for the SMA6863MZ and SMA6865MZ), V _{IN} =0 to 5V Inductive load
	tr	-	60	-	-	100	-	-	60	-	ns	
	ttr	-	110	-	-	120	-	-	100	-	ns	
	td(off)	-	690	-	-	740	-	-	680	-	ns	
	tf	-	30	-	-	30	-	-	20	-	ns	
Low Side Switching Time	td(on)	-	670	-	-	790	-	-	640	-	ns	V _{BB} =300V, V _{CC} =15V, I _D =1.5A (2.5A for the SMA6863MZ and SMA6865MZ), V _{IN} =0 to 5V Inductive load
	tr	-	70	-	-	110	-	-	65	-	ns	
	ttr	-	120	-	-	130	-	-	100	-	ns	
	td(off)	-	590	-	-	700	-	-	560	-	ns	
	tf	-	30	-	-	30	-	-	20	-	ns	

Internal Block Diagram



Typical Connection Diagram



When the current limiter function is used (OCL and SD1 are connected)

External Dimensions (ZIP24 [SMA24Pin])

(Unit : mm)

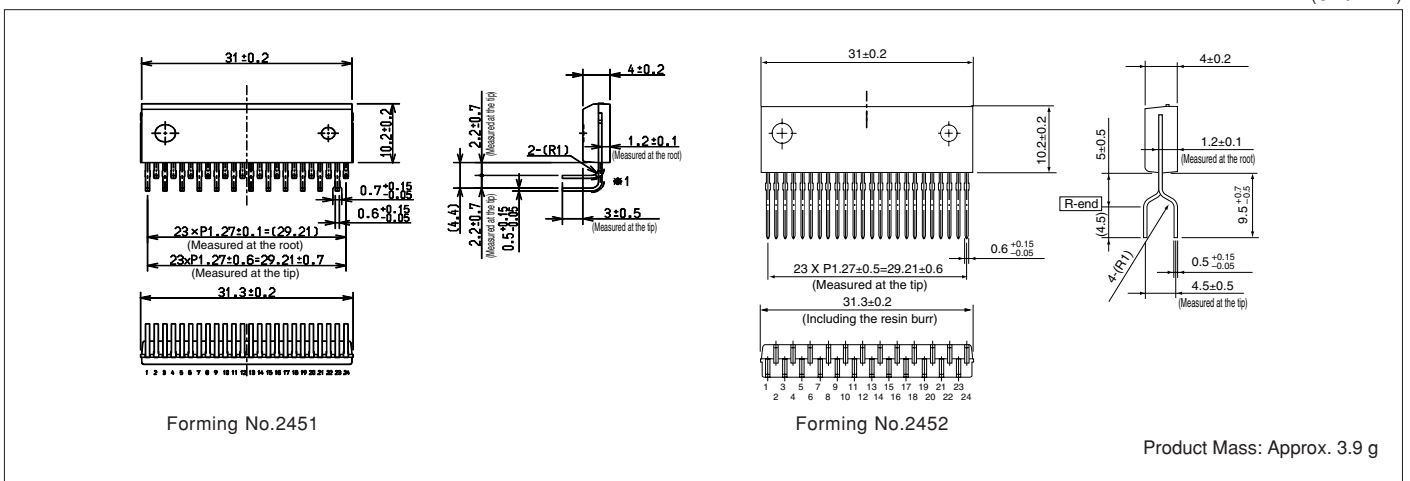

Forming No.2451

Forming No.2452

Product Mass: Approx. 3.9 g

SLA6860MZ Series

Built-in Overcurrent Protection, Thermal Shutdown, and Overcurrent Limiting Circuits

Features

- Built-in boot diode with 210Ω limiting resistor
- Built-in overcurrent protection circuit (OCP)
- Overcurrent protection with off-time period adjustable by an external capacitor
- Overcurrent limiting operation
- Built-in thermal shutdown (TSD) circuit
- Externally controllable shutdown operation

Absolute Maximum Ratings

(T_a=25°C)

Parameter	Symbol	Ratings		Unit	Conditions
		SLA6868MZ	SLA6870MZ		
MOSFET Output Breakdown Voltage	V _{DSS}	500		V	V _{CC} =15V, I _D =100μA, V _{IN} =0V
Control Supply Voltage (V _{CC})	V _{CC}	20		V	Between V _{CC} and COM
Control Supply Voltage (Bootstrap)	V _{BS}	20		V	Between V _B and HS (U, V, W)
Output Current (continuous)	I _O	2.5	3.0	A	
Output Current (pulse)	I _{OP}	3.75	4.5	A	PW≤100μs, duty=1%
Input Voltage	V _{IN}	-0.5 to +7		V	H _{IN1} to H _{IN3} , L _{IN1} to L _{IN3}
Thermal Resistance (Junction to Case)	θ _{J-C}	3.8		°C/W	All elements operating
Thermal Resistance (Junction to Ambient Air)	θ _{J-A}	25		°C/W	All elements operating
Operating Case Temperature	T _C	-20 to +100		°C	
Junction Temperature (Power part)	T _J	150		°C	
Storage Temperature	T _{STG}	-40 to +150		°C	

Recommended Operating Conditions

Parameter	Symbol	Ratings						Unit	Conditions
		SLA6868MZ			SLA6870MZ				
		min.	typ.	max.	min.	typ.	max.		
Main Supply Voltage	V _{BB}	–	300	400	–	300	400	V	Between V _{BB} and LS
Control Supply Voltage	V _{CC}	13.5	–	16.5	13.5	–	16.5	V	Between V _{CC} and COM
RC Pull-up Resistor	RR	33	–	390	33	–	390	kΩ	V _{RC} =5V
RC Noise Eliminating Capacitor	CC	1	–	4.7	1	–	4.7	nF	V _{RC} =5V
SD1 Pull-up Resistor	RL	3.3	–	10	3.3	–	10	kΩ	V _L =5V
SD1 Noise Eliminating Capacitor	CL	1	–	10	1	–	10	nF	V _L =5V
SD2 Pull-up Resistor	R _{UP2}	3.3	–	10	3.3	–	10	kΩ	V _{UP2} =5V
SD2 Noise Eliminating Capacitor	C _{SD2}	1	–	10	1	–	10	nF	V _{UP2} =5V
Input Signal Dead Time	t _{DEAD}	1.5	–	–	1.5	–	–	μs	T _J =-20°C to +150°C
Minimum Input Pulse Width	T _W	0.5	–	–	0.5	–	–	μs	

Electrical Characteristics

(T_a=25°C)

Parameter	Symbol	Ratings						Unit	Conditions	
		SLA6868MZ			SLA6870MZ					
		min.	typ.	max.	min.	typ.	max.			
Control Supply Current	I _{CC}	–	4.2	7	–	4.2	7	mA	V _{CC} =15V	
Boot Supply Current	I _B	–	135	380	–	135	380	μA	V _B =15V, H _{IN} =5V	
Input Voltage	V _{IH}	–	2.9	3.4	–	2.9	3.4	V	V _{CC} =15V	
	V _{IL}	1.6	2.1	–	1.6	2.1	–			
Undervoltage Lock Out	UV _{HL}	9.0	10.0	11.0	9.0	10.0	11.0	V	Between V _B and U(V,W)	
	UV _{HH}	9.5	10.5	11.5	9.5	10.5	11.5			
Undervoltage Lock Out	UV _{LL}	10.0	11.0	12.0	10.0	11.0	12.0	V	Between V _{CC} and COM	
	UV _{LH}	10.5	11.5	12.5	10.5	11.5	12.5			
Thermal Protection and Release Threshold	T _{DH}	120	135	150	120	135	150	°C	V _{CC} =15V	
	T _{DL}	100	115	130	100	115	130			
Overcurrent Protection Trip Voltage	V _{TRIP}	–	1.0	–	–	1.0	–	V	V _{CC} =15V	
Current Limiting Reference Voltage	V _{LIM}	–	0.53	–	–	0.53	–	V	V _{CC} =15V	
Overcurrent Protection Retention Time	t _P	–	2	–	–	2	–	ms	V _{RC} =5V, RR=360kΩ, CC=0.0047μF	
Boot Diode Leakage Current	I _{LBD}	–	–	10	–	–	10	μA	V _R =500V	
Boot Diode Forward Voltage	V _{FB}	–	0.8	1.3	–	0.8	1.3	V	I _F =0.05A	
Boot Diode Series Resistance	R _{BD}	–	210	–	–	210	–	Ω		
MOSFET Output Breakdown Voltage	V _{DSS}	500	–	–	500	–	–	V	V _{CC} =15V, I _D =100μA, V _{IN} =0V	
MOSFET Output Leakage Current	I _{DSS}	–	–	100	–	–	100	μA	V _{CC} =15V, V _{DS} =500V, V _{IN} =0V	
MOSFET DC ON Resistance	R _{DS(ON)}	–	2.0	2.4	–	1.4	1.7	Ω	V _{CC} =15V, I _D =1.25A (1.5A for SLA6870MZ), V _{IN} =5V	
MOSFET Diode Forward Voltage	V _{SD}	–	1.1	1.5	–	1.0	1.5	V	V _{CC} =15V, I _D =1.25A (1.5A for SLA6870MZ), V _{IN} =0V	
High Side Switching Time	td(on)	–	820	–	–	755	–	ns	V _{BB} =300V, V _{CC} =15V, I _D =2.5A (3.0A for SLA6870MZ), V _{IN} =0 to 5V Inductive load	
	tr	–	100	–	–	65	–			
	trr	–	120	–	–	100	–			
	td(off)	–	740	–	–	680	–			
	tf	–	30	–	–	15	–			
Low Side Switching Time	td(on)	–	790	–	–	645	–	ns		V _{BB} =300V, V _{CC} =15V, I _D =2.5A (3.0A for SLA6870MZ), V _{IN} =0 to 5V Inductive load
	tr	–	110	–	–	70	–			
	trr	–	130	–	–	105	–			
	td(off)	–	700	–	–	560	–			
	tf	–	30	–	–	20	–			

Internal Block Diagram



Typical Connection Diagram

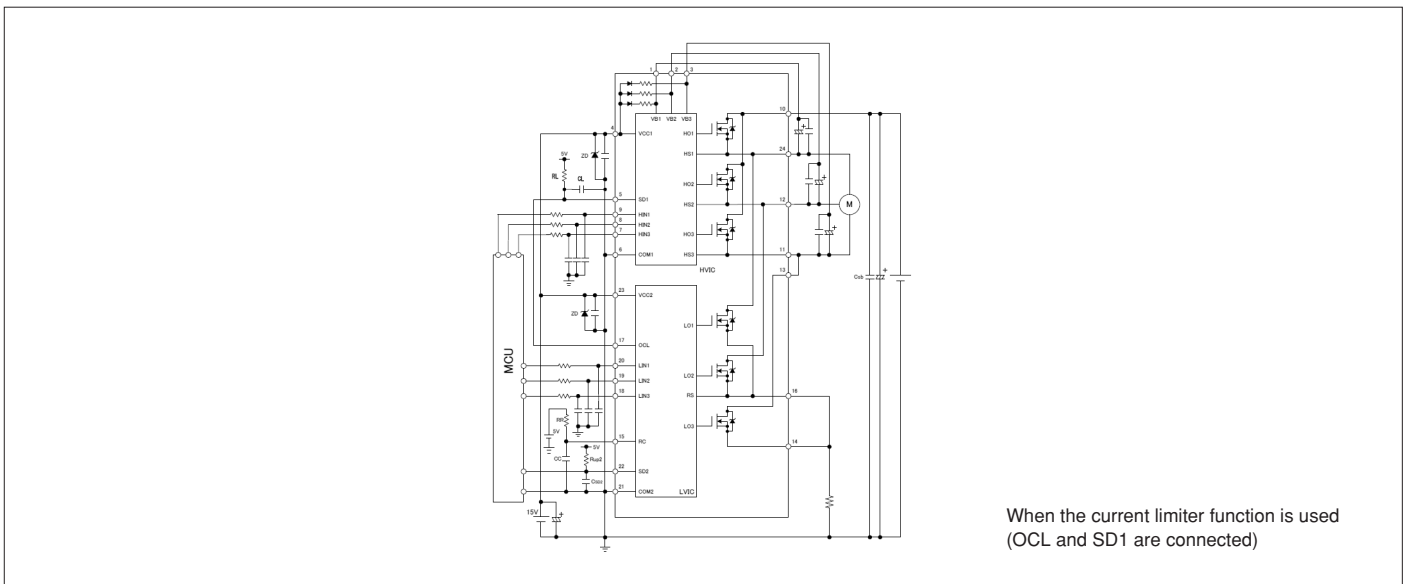

When the current limiter function is used (OCL and SD1 are connected)

External Dimensions (ZIP24 with Fin [SLA24Pin])

(Unit : mm)

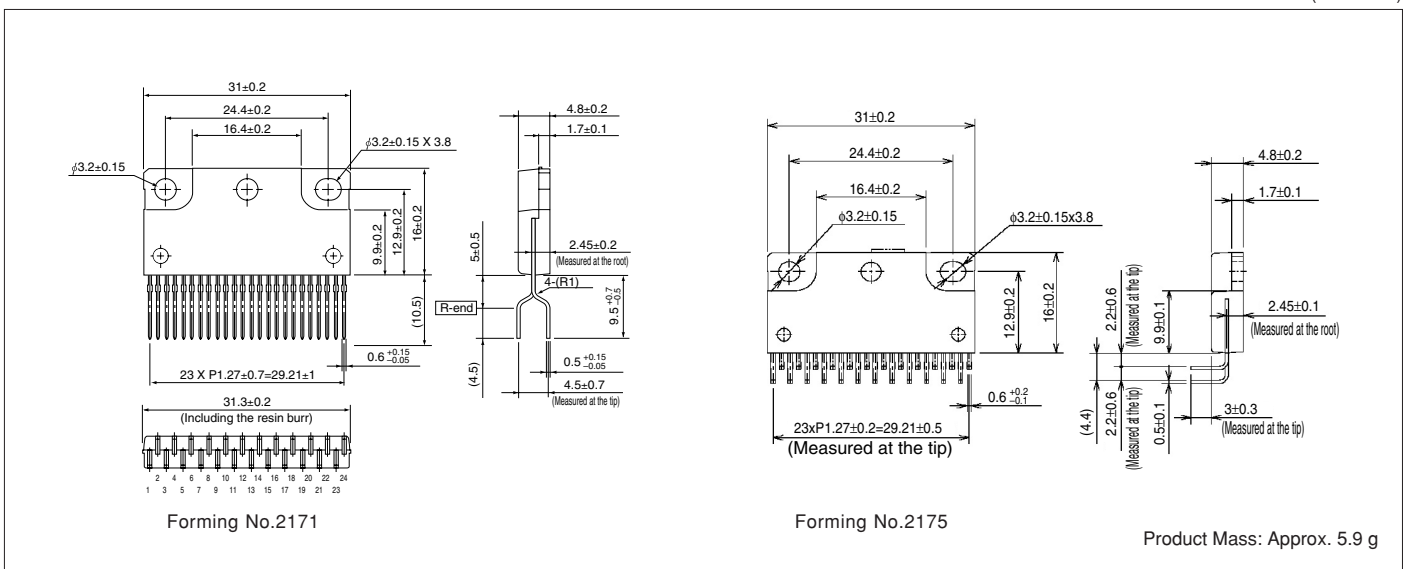

SIM6800M Series Overcurrent Protection, Thermal Shutdown, Built-in Current Limiting Function, 3 Shunt Support, DIP Package

Features

- Ideal for driving refrigerator compressors and the fan motor (built-in motor) of air conditioners
- Six MOSFETs for 3-phase bridge and pre-drive circuits (HVIC, LVIC) incorporated in single package
(For SIM6822M and SIM68227M, the 6 MOSFETs are replaced by 6 IGBTs and 6 FRDs)
- New package (DIP-40) that separates control signal pins and high voltage pins
- 3-shunt configuration allows configuration of vector control
- Built-in boot diode with limiting resistor
- Built-in undervoltage lockout (UVLO) circuit
- Built-in overcurrent protection circuit (OCP)
- Built-in thermal shutdown (TSD) function
- Built-in current limiter function (OCL)
- Error (FO) pin with shutdown input function

Absolute Maximum Ratings

(Ta=25°C)

Parameter	Symbol	Ratings				Unit	Conditions
		SIM6811M	SIM6812M	SIM6822M	SIM6827M		
MOSFET Output Breakdown Voltage	V _{DSS}	500	500	600	600	V	V _{CC} =15V, V _{IN} =0V
Control Supply Voltage	V _{CC}	20	20	20	20	V	Between V _{CC} and COM
Control Supply Voltage (Bootstrap)	V _{BS}	20	20	20	20	V	Between V _B and HS(U, V, W)
Output Current (continuous)	I _o	2.0	2.5	5.0	5.0	A	
Output Current (pulse)	I _{op}	3.0	3.75	7.5	7.5	A	PW≤100μs, duty=1%
Input Voltage	V _{IN}	-0.5 to +7	-0.5 to +7	-0.5 to +7	-0.5 to +7	V	
Thermal Resistance (MOSFET or IGBT (Junction to Case))	θ _{j-c}	3.6	3.6	3.6	3.6	°C/W	All elements operating
Thermal Resistance (MOSFET or IGBT (Junction to Ambient Air))	θ _{j-a}	25	25	25	25	°C/W	All elements operating
Operating Case Temperature	T _{op}	-20 to +100	-20 to +100	-20 to +100	-20 to +100	°C	
Junction Temperature (Power part)	T _{ch}	+150	+150	+150	+150	°C	
Storage Temperature	T _{stg}	-40 to +150	-40 to +150	-40 to +150	-40 to +150	°C	

Recommended Operating Conditions

Parameter	Symbol	Ratings												Unit	Conditions
		SIM6811M			SIM6812M			SIM6822M			SIM6827M				
		min.	typ.	max.	min.	typ.	max.	min.	typ.	max.	min.	typ.	max.		
Main Supply Voltage	V _{BB}	-	-	400	-	-	400	-	-	400	-	-	400	V	Between V _{BB} and LS
Control Supply Voltage	V _{CC}	13.5	15	16.5	13.5	15	16.5	13.5	15	16.5	13.5	15	16.5	V	Between V _{CC} and COM
Input Signal Dead Time	t _{dead}	1.5	-	-	1.5	-	-	1.5	-	-	1.5	-	-	μs	
Minimum Input Pulse Width	t _w	0.5	-	-	0.5	-	-	0.5	-	-	0.5	-	-	μs	
Bootstrap Capacitor Capacitance	C _{boot}	1	-	-	1	-	-	1	-	-	1	-	-	μF	
FO Pull-up Resistor	R _{FO}	3.3	-	10	3.3	-	10	3.3	-	10	3.3	-	10	kΩ	
FO Capacitor Capacitance	C _{FO}	0.001	-	0.01	0.001	-	0.01	0.001	-	0.01	0.001	-	0.01	μF	

Electrical Characteristics

(Ta=25°C)

Parameter	Symbol	Ratings												Unit	Conditions
		SIM6811M			SIM6812M			SIM6822M			SIM6827M				
		min.	typ.	max.	min.	typ.	max.	min.	typ.	max.	min.	typ.	max.		
Control Supply Current	I _{CC}	-	3.2	4.5	-	3.2	4.5	-	3.2	4.5	-	3.2	4.5	mA	V _{CC} =15V
Boot Supply Current	I _B	-	140	400	-	140	400	-	140	400	-	140	400	μA	V _B =15V, I _{IN} =5V, per phase
Input Voltage	V _{IH}	-	2	2.5	-	2	2.5	-	2	2.5	-	2	2.5	V	V _{CC} =15V, Output:ON
	V _{IL}	1	1.5	-	1	1.5	-	1	1.5	-	1	1.5	-	V	V _{CC} =15V, Output:OFF
FO Input Threshold Voltage	V _{IH}	-	2	2.5	-	2	2.5	-	2	2.5	-	2	2.5	V	V _{CC} =15V, Fo:Passive
	V _{IL}	1	1.5	-	1	1.5	-	1	1.5	-	1	1.5	-	V	V _{CC} =15V, Fo:Active
Input Current	I _{IH}	-	230	500	-	230	500	-	230	500	-	230	500	μA	V _{CC} =15V, V _{IN} =5V
	I _{IL}	-	-	2	-	-	2	-	-	2	-	-	2	μA	V _{CC} =15V, V _{IN} =0V
Undervoltage Lock Out (high side)	UV _{HL}	9.0	10.0	11.0	9.0	10.0	11.0	9.0	10.0	11.0	9.0	10.0	11.0	V	Between V _B and U(V, W)
	UV _{HH}	9.5	10.5	11.5	9.5	10.5	11.5	9.5	10.5	11.5	9.5	10.5	11.5	V	
Undervoltage Lock Out (low side)	UV _{LL}	10.0	11.0	12.0	10.0	11.0	12.0	10.0	11.0	12.0	10.0	11.0	12.0	V	Between V _{CC} and COM
	UV _{LH}	10.5	11.5	12.5	10.5	11.5	12.5	10.5	11.5	12.5	10.5	11.5	12.5	V	
FO Pin Output Voltage	V _{FOL}	0	-	0.5	0	-	0.5	0	-	0.5	0	-	0.5	V	V _{CC} =15V, V _{FO} =5V, R _{FO} =10kΩ
	V _{FOH}	4.8	-	-	4.8	-	-	4.8	-	-	4.8	-	-	V	
OCL Pin Output Voltage	V _{OCLL}	0	-	0.5	0	-	0.5	0	-	0.5	0	-	0.5	V	V _{CC} =15V
	V _{OCLH}	4.5	-	5.5	4.5	-	5.5	4.5	-	5.5	4.5	-	5.5	V	
Current Limiting Reference Voltage	V _{LIM}	-	0.65	-	-	0.65	-	-	0.65	-	-	0.65	-	V	V _{CC} =15V
Overcurrent Protection Trip Voltage	V _{TRIP}	-	1.0	-	-	1.0	-	-	1.0	-	-	1.0	-	V	V _{CC} =15V
Overcurrent Protection Retention Time	T _p	-	25	-	-	25	-	-	25	-	-	25	-	μs	V _{CC} =15V
OCP Blanking Time	T _{bK(OCP)}	-	2.0	-	-	2.0	-	-	2.0	-	-	2.0	-	μs	V _{CC} =15V
OCL Blanking Time	T _{bK(OCL)}	-	2.0	-	-	2.0	-	-	2.0	-	-	2.0	-	μs	V _{CC} =15V
Terminal Protection and Release Threshold	T _{DH}	135	150	165	135	150	165	135	150	165	135	150	165	°C	V _{CC} =15V, No FIN
	T _{DL}	105	120	135	105	120	135	105	120	135	105	120	135	°C	
Boot Diode Forward Voltage	V _{FB}	-	1.0	1.3	-	1.0	1.3	-	1.0	1.3	-	1.0	1.3	V	I _F =0.15A
Boot Diode Series Resistance	R _{Bd}	-	60	-	-	60	-	-	60	-	-	60	-	Ω	
MOSFET Output Breakdown Voltage	V _{DSS}	500	-	-	500	-	-	-	-	-	-	-	-	V	V _{CC} =15V, I _D =100μA, V _{IN} =0V
IGBT Output Breakdown Voltage	V _{CES}	-	-	-	-	-	-	-	-	-	-	-	-	V	V _{CC} =15V, I _{CE} =1mA, V _{IN} =0V
MOSFET Output Leakage Current	I _{DSS}	-	-	100	-	-	100	-	-	-	-	-	-	μA	V _{CC} =15V, V _{DS} =500V, V _{IN} =0V
IGBT Output Leakage Current	I _{CES}	-	-	-	-	-	-	-	-	1	-	-	1	mA	V _{CC} =15V, V _{CE} =600V, V _{IN} =0V
MOSFET DC ON Resistance	R _{DS(ON)}	-	3.2	4.0	-	2.0	2.4	-	-	-	-	-	-	Ω	V _{CC} =15V, I _D =1.0A (1.25A for the SIM6812M), V _{IN} =5V
IGBT Output Saturation Voltage	V _{CE(sat)}	-	-	-	-	-	-	1.75	2.2	-	1.75	2.2	-	V	V _{CC} =15V, I _C =5.0A, V _{IN} =5V
Diode Forward Voltage	V _{SD}	-	1.0	1.5	-	1.0	1.5	-	2.0	2.4	-	2.0	2.4	V	V _{CC} =15V, I _{SD} =1.0A (1.25A for the SIM6812M, I _{EC} =5A for the SIM6822M, 27M), V _{IN} =0V
High Side Switching Time	t _{d(on)}	-	770	-	-	910	-	-	740	-	-	1030	-	ns	V _{BB} =300V, V _{CC} =15V, I _D =1.0A, (1.25A for the SIM6812M, I _C =5A for the SIM6822M, 27M), V _{IN} =0 to 5V, Inductive load
	t _r	-	70	-	-	100	-	-	70	-	-	180	-		
	t _{rr}	-	150	-	-	140	-	-	80	-	-	100	-		
	t _{d(off)}	-	690	-	-	700	-	-	570	-	-	590	-		
	t _f	-	30	-	-	40	-	-	100	-	-	150	-		
Low Side Switching Time	t _{d(on)}	-	690	-	-	875	-	-	690	-	-	1030	-	ns	
	t _r	-	90	-	-	110	-	-	100	-	-	240	-		
	t _{rr}	-	150	-	-	155	-	-	80	-	-	100	-		
	t _{d(off)}	-	650	-	-	775	-	-	540	-	-	540	-		
	t _f	-	50	-	-	35	-	-	100	-	-	150	-		

Internal Block Diagram

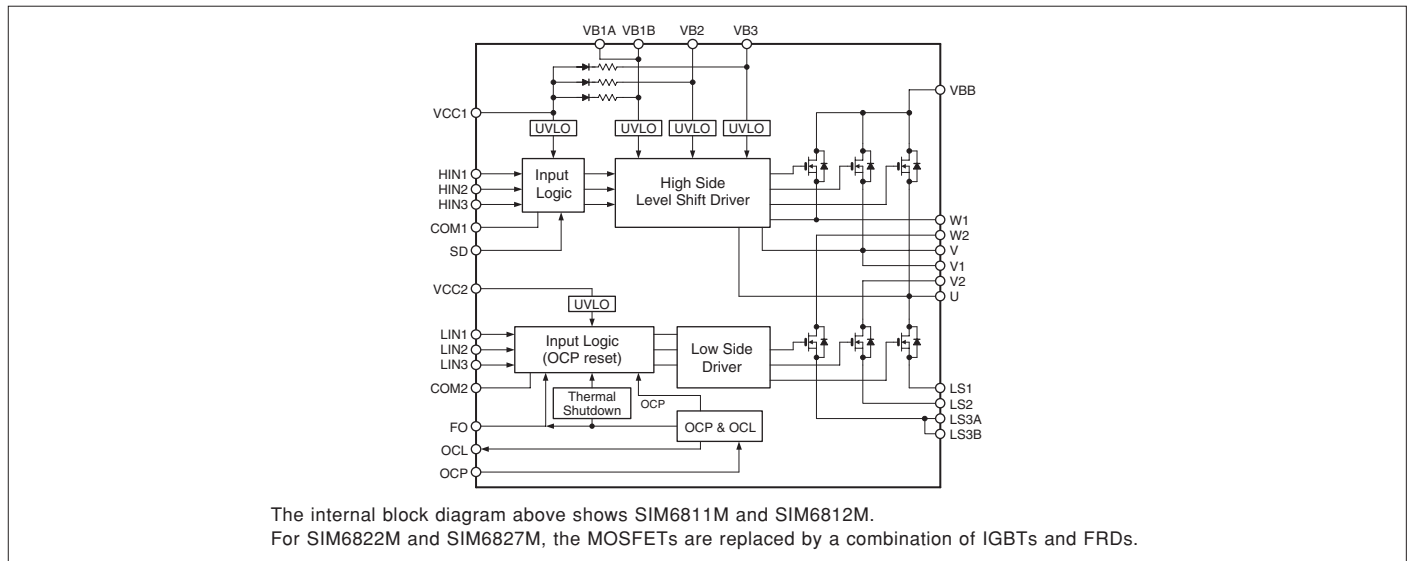

Typical Connection Diagram

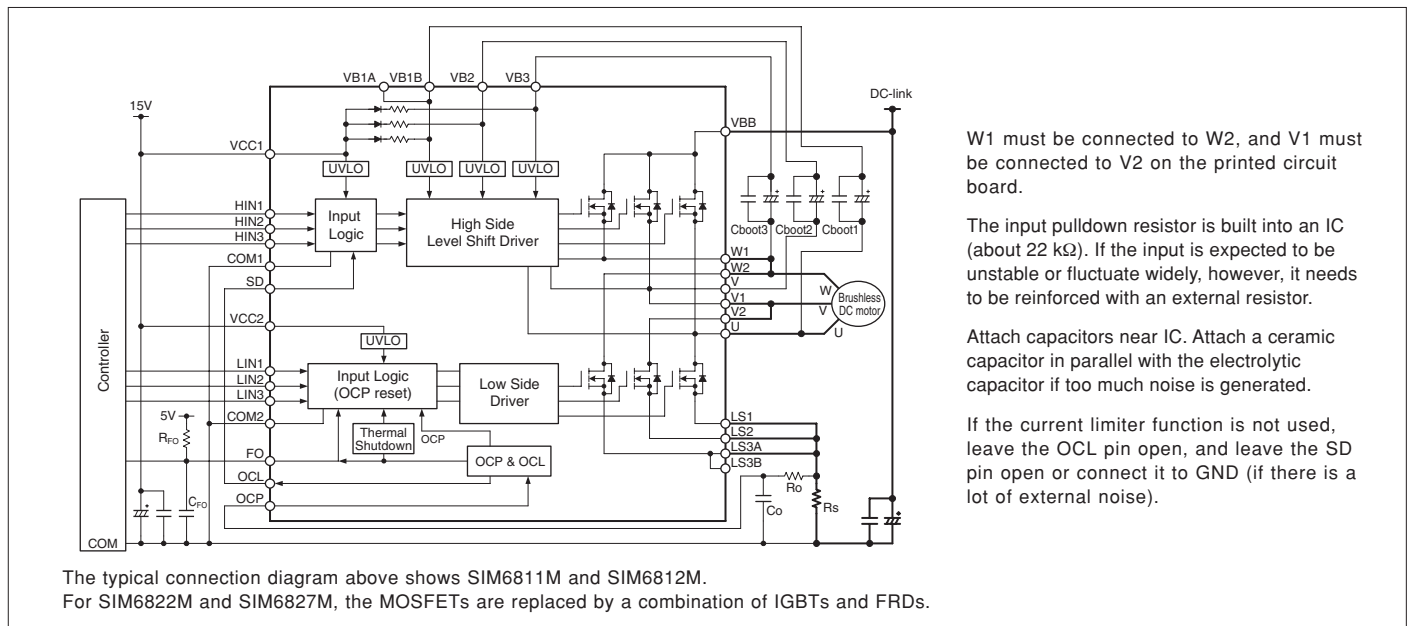

External Dimensions

(Unit : mm)

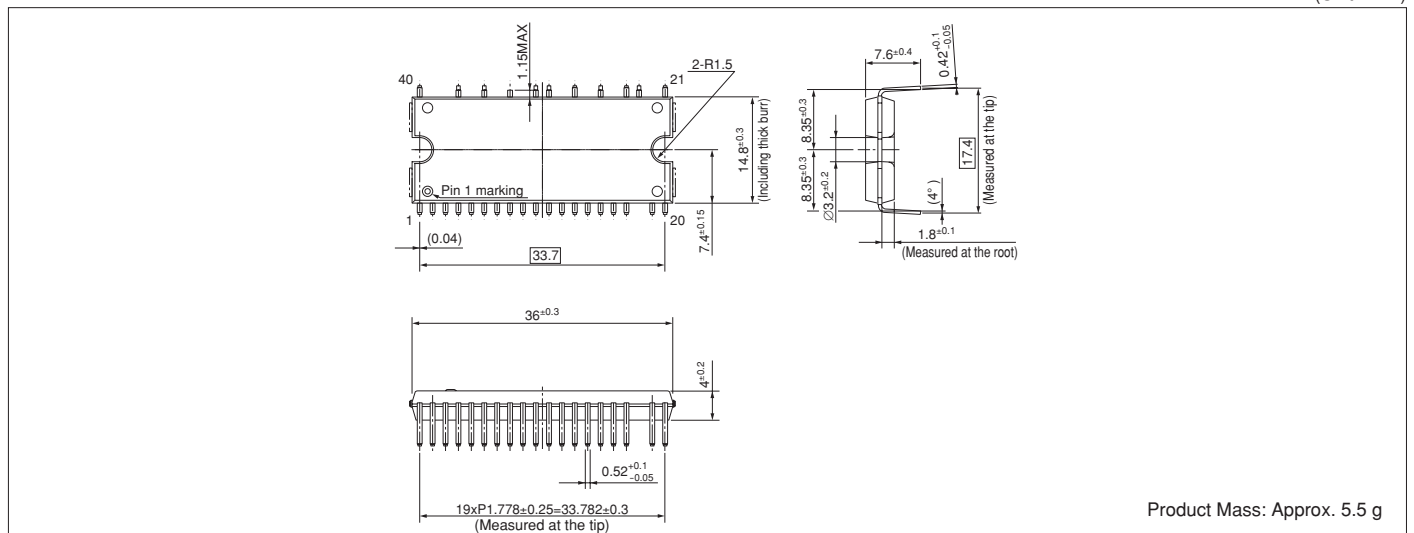

SCM1240M Series IGBT Output Element, Built-in Thermal Shutdown, Overcurrent Protection, and Shoot Through Prevention Circuits

■ Features

- Six IGBTs and six FRDs for the 3-phase bridge, a pre-drive IC, and a boot diode are integrated into a single package (For SCM1248M, the 6 IGBTs and 6 FRDs are replaced with 6 MOSFETs)
- Best for driving air conditioner compressors, washing machine drums, and refrigerator compressors
- Built-in shoot through prevention (STP) circuit (when the ON signal is input simultaneously)
- All IGBTs can be shut down when commonly connected to the FO pin.
- Three built-in boot diodes with limiting resistors
- Built-in undervoltage lock out (UVLO) circuit
- Built-in overcurrent protection (OCP) circuit
- Built-in thermal shut down (TSD) circuit
- Fail signal output during operation of the UVLO (low side only), OCP, or STP circuit
- Supports CMOS (3.3 and 5 V) input levels

■ Absolute Maximum Ratings

(T_a=25°C)

Parameter	Symbol	Ratings					Unit	Conditions
		SCM1241M	SCM1243MF	SCM1245MF	SCM1246MF	SCM1248M		
Supply Voltage	V _{DC}	450	450	450	450	400	V	Between V _{BB} and LS1 to LS3
Supply Voltage (Surge)	V _{DC(Surge)}	500	500	500	500	450	V	Between V _{BB} and LS1 to LS3
IGBT Output Breakdown Voltage	V _{CE(S)}	600	600	600	600	—	V	V _{CC} =15V, I _C =1mA, V _{IN} =0V
MOSFET Output Breakdown Voltage	V _{DSS}	—	—	—	—	500	V	V _{CC} =15V, I _D =1mA, V _{IN} =0V
Control Supply Voltage	V _{CC}	20	20	20	20	20	V	Between V _{CC} and COM
Control Supply Voltage (Bootstrap)	V _{BS}	20	20	20	20	20	V	Between V _{BS} and HS (U, V, W)
Output Current (continuous)	I _O	10	15	20	30	5	A	T _C =25°C
Output Current (pulse)	I _{OP}	20	30	30	45	7.5	A	PW≤1ms (100μs for the SCM1248M), Duty=1%, T _C =25°C
Input Voltage	V _{IN}	-0.5 to +7.0	-0.5 to +7.0	-0.5 to +7.0	-0.5 to +7.0	-0.5 to +7.0	V	Hin, Lin, OCP
Fo Pin Voltage	V _{FO}	7	7	7	7	7	V	Between Fo and COM
OCP Pin Voltage	V _{OCP}	-10 to +5.0	-10 to +5.0	-10 to +5.0	-10 to +5.0	-10 to +5.0	V	Between OCP and COM
Thermal Resistance IGBT or MOSFET (Junction to Case)	θ _{J-C,O} / θ _{J-C,F}	6.0 / 6.5	3.0 / 4.0	3.0 / 4.0	3.0 / 4.0	5.5 / —	°C/W	Per element in operation
Operating Case Temperature	T _{OP}	-20 to +100	-20 to +100	-20 to +100	-20 to +100	-20 to +100	°C	
Junction Temperature (Power part)	T _J	150	150	150	150	150	°C	
Storage Temperature	T _{STG}	-40 to +150	-40 to +150	-40 to +150	-40 to +150	-40 to +150	°C	
Insulation Breakdown Voltage	V _{ISO}	2,000	2,000	2,000	2,000	2,000	V	Between rear and lead pins, AC one minute

■ Recommended Operating Conditions

Parameter	Symbol	Ratings															Unit	Conditions
		SCM1241M			SCM1243MF			SCM1245MF			SCM1246MF			SCM1248M				
		min.	typ.	max.	min.	typ.	max.	min.	typ.	max.	min.	typ.	max.	min.	typ.	max.		
Main Supply Voltage	V _{BB}	—	300	400	—	300	400	—	300	400	—	300	400	—	300	400	V	Between V _{BB} and LS
Control Supply Voltage	V _{CC,VBS}	13.5	15	16.5	13.5	15	16.5	13.5	15	16.5	13.5	15	16.5	13.5	15	16.5	V	Between V _{CC} and COM
Minimum Input Pulse Width	t _{INmin(on)}	0.5	—	—	0.5	—	—	0.5	—	—	0.5	—	—	0.5	—	—	μs	ON pulse
	t _{INmin(off)}	0.5	—	—	0.5	—	—	0.5	—	—	0.5	—	—	0.5	—	—	μs	OFF pulse
Input Signal Dead Time	t _{DEAD}	1.0	—	—	1.0	—	—	1.0	—	—	1.0	—	—	1.0	—	—	μs	
FO Pull-up Voltage	V _{FO}	3.0	—	5.5	3.0	—	5.5	3.0	—	5.5	3.0	—	5.5	3.0	—	5.5	V	
FO Pull-up Resistance	R _{FO}	1.0	—	22	1.0	—	22	1.0	—	22	1.0	—	22	1.0	—	22	kΩ	
FO Noise Eliminating Capacitor	C _{FO}	0.001	—	0.01	0.001	—	0.01	0.001	—	0.01	0.001	—	0.01	0.001	—	0.01	μF	
Boot Capacitor	C _{BOOT}	10	—	220	10	—	220	10	—	220	10	—	220	10	—	220	μF	
Shunt resistor	R _S	27	—	—	18	—	—	18	—	—	12	—	—	67	—	—	mΩ	I _C <I _{OP} (I _D <I _{OP} for the SCM1248M)
RC filter resistor	R _O	—	—	100	—	—	100	—	—	100	—	—	100	—	—	100	Ω	
RC filter capacitor	C _O	—	—	2200	—	—	2200	—	—	2200	—	—	2200	—	—	2200	pF	
PWM Carrier Frequency	f _C	—	—	20	—	—	20	—	—	20	—	—	20	—	—	20	kHz	

■Electrical Characteristics

(T_a=25°C)

Parameter	Symbol	Ratings															Unit	Conditions	
		SCM1241M			SCM1243MF			SCM1245MF			SCM1246MF			SCM1248M					
		min.	typ.	max.	min.	typ.	max.	min.	typ.	max.	min.	typ.	max.	min.	typ.	max.			
Control Supply Current	I _{CC}	–	3	–	–	3	–	–	3	–	–	3	–	–	3	–	mA	V _{CC} =15V, 3circuit total	
Boot Supply Current	I _{BS}	–	140	–	–	140	–	–	140	–	–	140	–	–	140	–	μA	V _{B-HS} =15V, 1 circuit, V _{IN} =5V	
Input Voltage	V _{IH}	–	2.0	2.5	–	2.0	2.5	–	2.0	2.5	–	2.0	2.5	–	2.0	2.5	V	V _{CC} =15V, Output:ON	
	V _{IL}	1.0	1.5	–	1.0	1.5	–	1.0	1.5	–	1.0	1.5	–	1.0	1.5	–		V _{CC} =15V, Output:OFF	
Input Current	I _{IH}	–	230	500	–	230	500	–	230	500	–	230	500	–	230	500	μA	V _{CC} =15V, V _{IN} =5V	
Undervoltage Lock Out (high side)	UV _{HL}	10.0	11.0	12.0	10.0	11.0	12.0	10.0	11.0	12.0	10.0	11.0	12.0	10.0	11.0	12.0	V	Between V _{BS} and HS(U, V, W)	
	UV _{HH}	10.5	11.5	12.5	10.5	11.5	12.5	10.5	11.5	12.5	10.5	11.5	12.5	10.5	11.5	12.5			
Undervoltage Lock Out (low side)	UV _{LL}	10.0	11.0	12.0	10.0	11.0	12.0	10.0	11.0	12.0	10.0	11.0	12.0	10.0	11.0	12.0	V	Between V _{CC} and COM	
	UV _{LH}	10.5	11.5	12.5	10.5	11.5	12.5	10.5	11.5	12.5	10.5	11.5	12.5	10.5	11.5	12.5			
FO Pin Output Voltage	V _{FOL}	–	–	0.5	–	–	0.5	–	–	0.5	–	–	0.5	–	–	0.5	V	V _{CC} =15V, V _{FO} =5V, R _{FO} =10kΩ	
	V _{FOH}	4.8	–	–	4.8	–	–	4.8	–	–	4.8	–	–	4.8	–	–			
Overcurrent Protection Trip Voltage	V _{TRIP}	0.46	0.5	0.54	0.46	0.5	0.54	0.46	0.5	0.54	0.46	0.5	0.54	0.46	0.5	0.54	V	V _{CC} =15V	
Overcurrent Protection Retention Time	t _p	–	26	–	–	26	–	–	26	–	–	26	–	–	26	–	μs	V _{CC} =15V	
OCP Blanking Time	t _{bk}	–	1.65	–	–	1.65	–	–	1.65	–	–	1.65	–	–	1.65	–	μs	V _{CC} =15V	
Thermal Protection and Release Threshold	T _{DH}	–	150	–	–	150	–	–	150	–	–	150	–	–	150	–	°C	V _{CC} =15V	
	T _{DL}	–	120	–	–	120	–	–	120	–	–	120	–	–	120	–			
IGBT Output Breakdown Voltage	V _{CES}	600	–	–	600	–	–	600	–	–	600	–	–	–	–	–	V	V _{CC} =15V, I _C =1mA, V _{IN} =0V	
MOSFET Output Breakdown Voltage	V _{DSS}	–	–	–	–	–	–	–	–	–	–	–	500	–	–	–	V	V _{CC} =15V, I _D =1mA, V _{IN} =0V	
IGBT Output Leakage Current	I _{CES}	–	–	1	–	–	1	–	–	1	–	–	1	–	–	–	mA	V _{CC} =15V, V _{CE} =600V, V _{IN} =0V	
MOSFET Output Leakage Current	I _{DSS}	–	–	–	–	–	–	–	–	–	–	–	–	–	–	1	mA	V _{CC} =15V, V _{DS} =500V, V _{IN} =0V	
IGBT Output Saturation Voltage	V _{CE(sat)}	–	1.7	2.2	–	1.7	2.2	–	1.7	2.2	–	1.7	2.2	–	–	–	V	V _{CC} =15V, I _C =I _O (Rated Current), V _{IN} =5V	
MOSFET DC ON Resistance	R _{DS(ON)}	–	–	–	–	–	–	–	–	–	–	–	–	0.55	0.8	–	Ω	V _{CC} =15V, I _D =2.5A, V _{IN} =5V	
Diode Forward Voltage	V _{SD}	–	1.7	2.2	–	1.75	2.2	–	1.9	2.4	–	1.5	2.0	–	0.9	1.4	V	V _{CC} =15V, I _{EC} =I _O (Rated Current), I _{SD} =2.5A (SCM1248M), V _{IN} =0V	
Boot Diode Forward Voltage	V _{FB}	–	1.1	1.3	–	1.1	1.3	–	1.1	1.3	–	1.1	1.3	–	1.1	1.3	V	I _F =0.15A	
Boot Diode Series Resistance	R _B	–	22	–	–	22	–	–	22	–	–	22	–	–	22	–	Ω		
High Side Switching Time	td(on)	–	590	–	–	600	–	–	695	–	–	660	–	–	820	–	ns	V _{CC} =300V, V _{CC} =15V, I _C =I _D =I _O (Rated Current), V _{IN} =0 to 5V, Inductive load	
	t _r	–	80	–	–	70	–	–	95	–	–	110	–	–	90	–			
	t _{rr}	–	60	–	–	70	–	–	75	–	–	60	–	–	130	–			
	td(off)	–	550	–	–	620	–	–	675	–	–	700	–	–	700	–			
	t _f	–	90	–	–	60	–	–	55	–	–	50	–	–	20	–			
Low Side Switching Time	td(on)	–	570	–	–	600	–	–	715	–	–	660	–	–	830	–	ns		
	t _r	–	100	–	–	100	–	–	135	–	–	150	–	–	90	–			
	t _{rr}	–	70	–	–	80	–	–	115	–	–	70	–	–	140	–			
	td(off)	–	560	–	–	600	–	–	670	–	–	690	–	–	710	–			
	t _f	–	100	–	–	70	–	–	50	–	–	50	–	–	20	–			

Internal Block Diagram (One of three phases)

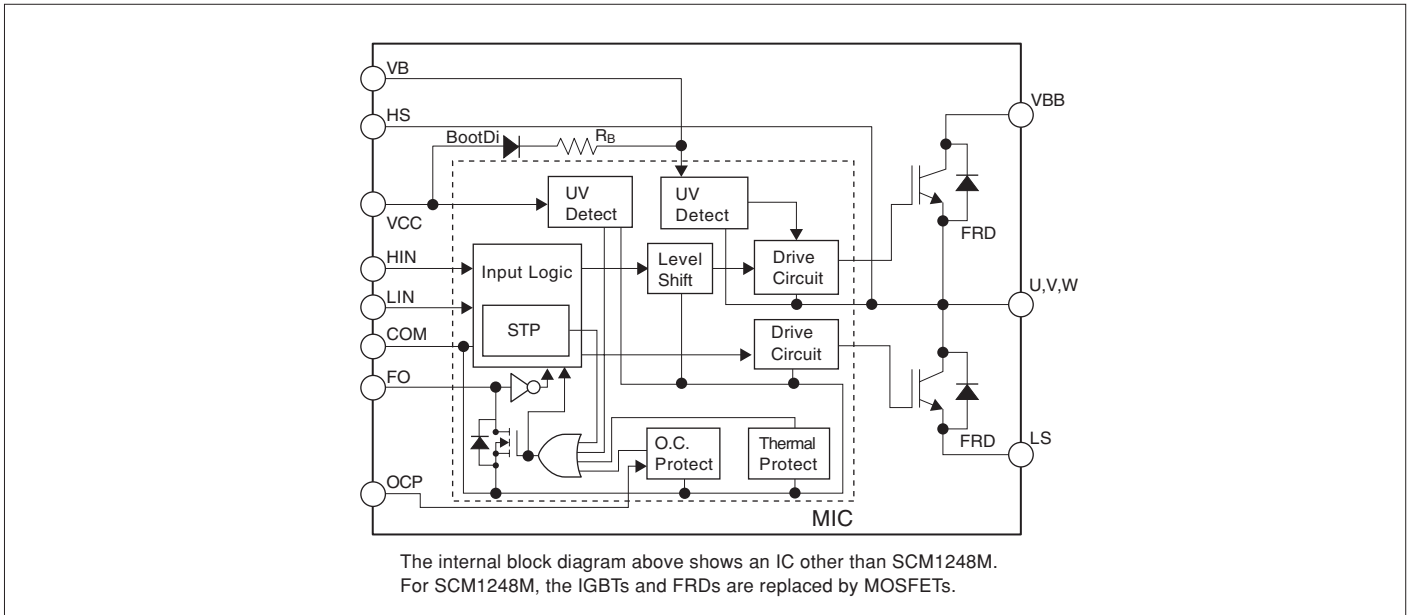

Typical Connection Diagram

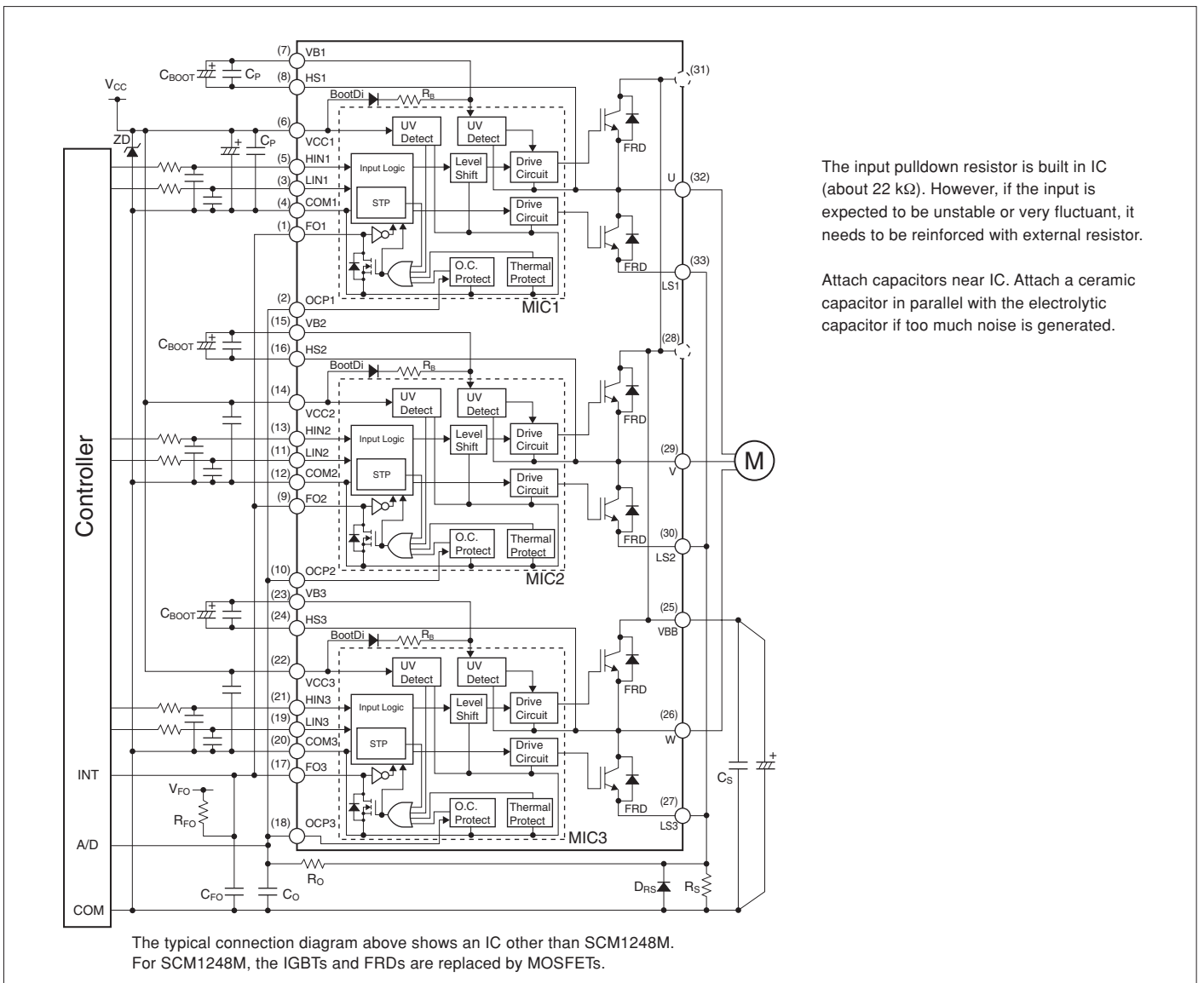

The input pulldown resistor is built in IC (about 22 kΩ). However, if the input is expected to be unstable or very fluctuant, it needs to be reinforced with external resistor.

Attach capacitors near IC. Attach a ceramic capacitor in parallel with the electrolytic capacitor if too much noise is generated.

External Dimensions (DIP33)

(Unit : mm)

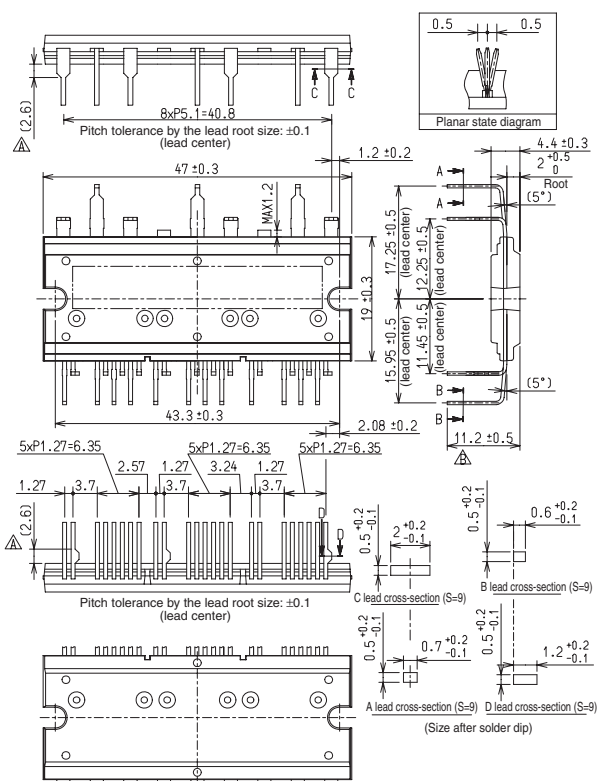

Without Fin
(SCM1240M)

Forming No. 2551
Product Mass: Approx. 10.8g

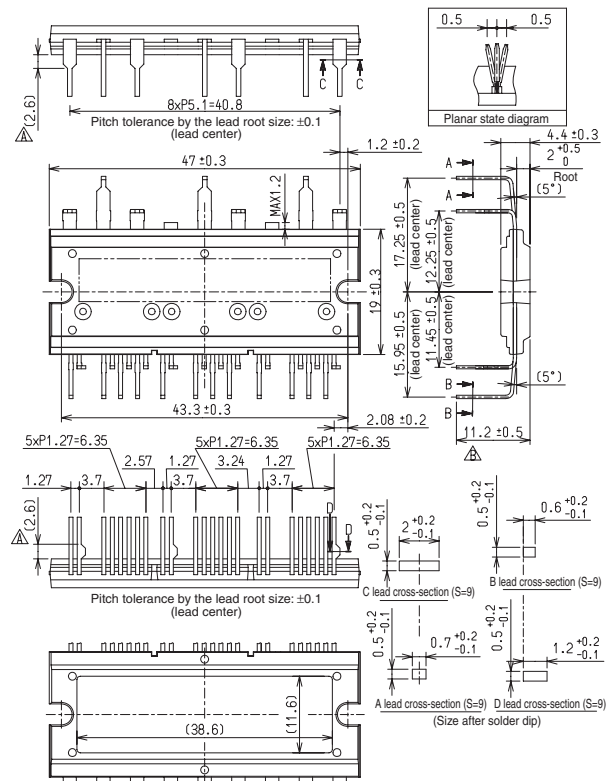

With Fin
(SCM1240MF)

Forming No. 2552
Product Mass: Approx. 11.8g

Selection Guide

<AC/DC>

Non-isolated Type

Series Name	Part Number	Output Current	Input Voltage	R _{DS(ON)} (Max)	Package	Circuit Type	Features	Applications	Page
LC5200	LC5202D	0.5A	250V	2.2Ω	DIP8	Buck	<ul style="list-style-type: none"> • Low component count • Power factor correction • Built-in analog dimming function • OCP: Latch shutdown • TSD: Auto restart 	LED light bulbs, etc.	136
	LC5205D		450V	6.0Ω					
	LC5202S		250V	2.2Ω	SOP8				
	LC5205S		450V	6.0Ω					
	LC5203D	1.0A	250V	1.3Ω	DIP8				
	LC5210D		450V	3.0Ω					
LC5220	LC5222D	0.5A	250V	2.2Ω	DIP8	Buck/ Buck-boost	<ul style="list-style-type: none"> • Low component count • Power factor correction • Built-in analog dimming function • External latch function • OCP/OPP: Latch shutdown • TSD: Auto restart 	LED light bulbs, etc.	138
	LC5225D		450V	6.0Ω					
	LC5222S		250V	2.2Ω	SOP8				
	LC5225S		450V	6.0Ω					
	LC5223D	1.0A	250V	1.3Ω	DIP8				
	LC5226D		450V	3.0Ω					
LC5550	LC5555LD	2.5A	650V	3.95Ω	DIP8	Buck	<ul style="list-style-type: none"> • Power factor correction • Harmonics standard compliant (Class C) • High efficiency • Universal input • OCP: Pulse by pulse • OVP/OLP/TSD: Latch shutdown 	LED light bulbs LED downlights LED straight tube lamps, etc.	140
	LC5556LD	4.0A		1.9Ω					
LC5510	LC5511D	–	650V	3.95Ω	DIP8	Flyback	<ul style="list-style-type: none"> • Power factor correction • Harmonics standard compliant (Class C) • High efficiency • Universal input • OCP: Pulse by pulse • OVP/OLP: Auto restart • TSD: Latch shutdown 	LED downlights LED straight tube lamps, etc.	142
	LC5513D	–		1.9Ω					
LC5560	LC5565LD	–	650V	3.95Ω	DIP8	Flyback	<ul style="list-style-type: none"> • Power factor correction • Harmonics standard compliant (Class C) with light load • High efficiency • Universal input • Built-in analog dimming function • OCP: Pulse by pulse • OVP/OLP/TSD: Latch shutdown 	LED light bulbs LED downlights LED straight tube lamps, etc.	144
	LC5566LD	–		1.9Ω					

Isolated type

Series Name	Part Number	MOSFET		Package	Circuit Type	Features	Applications	Page
		V _{DSS}	R _{DS(ON)} (Max)					
LC5520	LC5521D	650V	3.95Ω	DIP8	Flyback	<ul style="list-style-type: none"> • Power factor correction • Harmonics standard compliant (Class C) • High efficiency • Universal input • OCP: Pulse by pulse • OVP/OLP: Auto restart • TSD: Latch shutdown 	LED downlights LED straight tube lamps, etc.	146
	LC5523D	650V	1.9Ω					
	LC5523F	650V	1.9Ω	TO220F-7	Flyback		Ceiling lights Street lights, etc.	
	LC5525F	650V	1.1Ω					
LC5540	LC5545LD	650V	3.95Ω	DIP8	Flyback	<ul style="list-style-type: none"> • Power factor correction • Harmonics standard compliant with light load (Class C) • High efficiency • Universal input • Analog dimming • OCP: Pulse by pulse • OVP/OLP/TSD: Latch shutdown 	LED downlights LED straight tube lamps, etc.	148
	LC5546LD	650V	1.9Ω					
	LC5548LD	800V	3.5Ω					
	LC5546LF	650V	1.9Ω	TO220F-7	Flyback		Ceiling lights Street lights, etc.	
	LC5547LF	650V	1.1Ω					
	LC5549LF	800V	1.7Ω					

<DC/DC>

Series Name	Part Number	Input Voltage Range	Output Current	Package	Features	Applications	Page
LC5700	LC5720S	8.5 to 50V	2A	HSOP8	Current mode PWM control Buck, Boost, Buck-Boost operations PWM dimming OCP/OVP/TSD	DC input LED lighting RGB LED lighting	150

LC5200 Series LED Driver ICs

Features

- Buck converter operations
- High breakdown voltage supply input: 250V (MAX), 450V (MAX)
- Built-in constant current control circuit
Built-in PWM type constant current control circuit
Output current can be controlled by REF pin input voltage
- Supports external PWM signal
Inputting PWM signal to PWM pin enables dimming control
Inputting Low signal to PWM pin enables turning off of all LED loads
- Protection functions
Undervoltage lockout function (UVLO)
Overcurrent protection function (OCP)...Latch shutdown
Thermal shutdown function (TSD)...Auto restart

Applications

- LED light bulbs
- LED lighting equipment

Lineup

Part Number	Output Current	Input Voltage	R _{DS(ON)} (Max)	Package
LC5202D	0.5A	250V	2.2Ω	DIP8
LC5205D		450V	6.0Ω	
LC5202S		250V	2.2Ω	
LC5205S	1.0A	450V	6.0Ω	SOP8
LC5203D		250V	1.3Ω	
LC5210D		450V	3.0Ω	

Absolute Maximum Ratings

(T_a = 25°C)

Parameter	Symbol	Ratings					Unit	Remarks	
		LC5202D	LC5202S	LC5205D	LC5205S	LC5203D			LC5210D
Output Current*1	I _o	0.5			1.0		A	Excluding when tw is less than 1μs	
Main Supply Voltage	V _{BB}	250		450		250	450	V	
Output Breakdown Voltage	V _{O(BR)}	250		450		250	450	V	
PWM Pin Voltage*2	V _{PWM}	-0.3 to V _Z					V		
REF Pin Voltage	V _{REF}	-0.3 to +V _{REG} +0.3					V		
SEN Pin Voltage	V _{SEN}	-0.3 to +4.0					V	Excluding when tw is less than 1μs	
Power Dissipation*3	P _D	1.73	0.85	1.73	0.85	1.73		W	Sanken Evaluation Board
Operating Ambient Temperature	T _a	-40 to +105					°C		
Storage Temperature	T _{stg}	-40 to +150					°C		
Junction Temperature	T _J	+150					°C		

- *1: The output current value may be limited, depending on the duty ratio, ambient temperature, and heating conditions. Do not exceed the junction temperature T_J under any circumstances.
 *2: There is a built-in zener diode between the PWM pin and GND. V_Z is the breakdown voltage of this internal zener diode, and V_Z = 6.3V (TYP). The maximum value of the inflow current is 1mA.
 *3: The power dissipation P_D varies depending on the pattern layout of the circuit board used. Refer to the Ta-PD characteristics curve.

Recommended Operating Conditions

Parameter	Symbol	Ratings								Unit
		LC5202D/S		LC5203D		LC5205D/S		LC5210D		
		min.	max.	min.	max.	min.	max.	min.	max.	
Supply Voltage	V _{BB}	25*1	200	25*1	200	25*1	400	25*1	400	V
Output Current (Average)	I _{O(AVG)}	-	0.4	-	0.8	-	0.4	-	0.8	A
REF Pin Voltage	V _{REF}	-	0.8	-	0.8	-	0.8	-	0.8	V
Case Temperature*2	T _c	-	105	-	105	-	105	-	105	°C

The recommended operating conditions show the operating conditions required to maintain normal circuit functions as shown in the electrical characteristics. In actual operation, the device must be used within the recommended operating conditions.

- *1: The minimum voltage depends on the LED used.
 *2: Defined at the center of the package. The junction temperature T_J is assumed to be 150°C or lower.

Electrical Characteristics

(T_a = 25°C, V_{BB} = 140V, unless otherwise specified)

Parameter	Symbol	Measurement Conditions	Ratings			Unit	Remarks
			min.	typ.	max.		
Supply Current	I _{BS}	When output is OFF	-	0.8	1.2	mA	
	I _B	During operation	-	2	-	mA	
Output MOSFET Breakdown Voltage	V _{DS(BR)}	I _D =1mA	250	-	-	V	LC5202D/S, LC5203D
			450	-	-	V	LC5205D/S, LC5210D
Output MOSFET ON Resistance	R _{DS(ON)}	I _D =0.5A	-	1.2	2.2	Ω	LC5202D/S
		I _D =1.0A	-	0.7	1.3	Ω	LC5203D
		I _D =0.5A	-	3.5	6	Ω	LC5205D/S
		I _D =1.0A	-	1.7	3	Ω	LC5210D
Output MOSFET Body Diode Forward Voltage	V _F	I _F =0.5A	-	0.8	1	V	LC5202D/S
		I _F =1.0A	-	0.75	1.2	V	LC5203D
		I _F =0.5A	-	0.8	0.9	V	LC5205D/S
		I _F =1.0A	-	0.88	1	V	LC5210D
UVLO Release Voltage	V _{UVLO(ON)}		-	14	-	V	V _{BB} pin voltage
UVLO Operation Voltage	V _{UVLO(OFF)}		-	13	-	V	V _{BB} pin voltage
REG Pin Output Voltage	V _{REG}	I _{REG} =-0.1mA	11.5	12	12.5	V	
REG Pin Output Current	I _{REG}	V _{REG} =11V	-	-	-2	mA	
REF Pin Input Voltage	V _{REF}		0	-	1	V	
REF Pin Inflow Current	I _{REF}		-10	-	10	μA	
Current Control Detection Voltage	V _{SEN}		V _{REF} -0.03	V _{REF}	V _{REF} +0.03	V	
OCP Detection Voltage	V _{OCP}		-	3	-	V	
SEN Pin Inflow Current	I _{SEN}		-10	-	10	μA	
PWM Blanking Time	t _{BLK}		-	400	-	ns	
PWM Oscillation Frequency	f _{PWM}	Duty=50%	-	-	200	kHz	
Output MOSFET Rising Time	t _r	I _o =0.4A	-	20	-	ns	
Output MOSFET Falling Time	t _f	I _o =0.4A	-	50	-	ns	
TSD Operating Temperature*	T _{TSD}		-	150	-	°C	
TSD Temperature Hysteresis*	T _{TSD(HYS)}		-	55	-	°C	
Thermal Resistance	θ _{J-a}	Sanken Evaluation Board	-	-	72	°C/W	LC52xxD
			-	-	147	°C/W	LC52xxS

For the polarity of current values, the sink is defined as "positive" and the source is defined as "negative" with respect to the IC.
 *: Control IC chip temperature (T_J)

External Dimensions

(Unit : mm)

LC52xxD (DIP8)

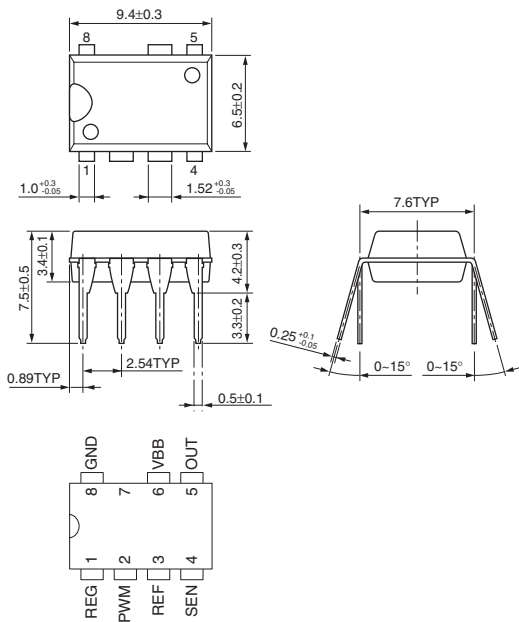

LC52xxS (SOP8)

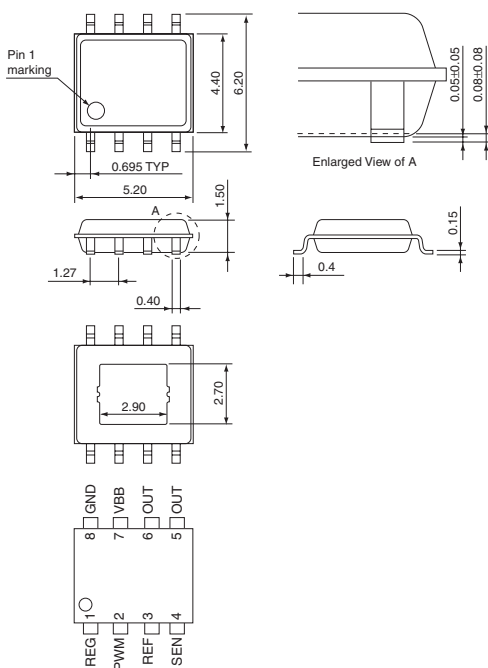

Pin Functions

Symbol	Pin No.		Function
	LC52xxD (DIP8)	LC52xxS (SOP8)	
REG	1	1	Output of the built-in regulator. Supplies current to the internal and external circuits. Connect a 0.1μF bypass capacitor near the pin.
PWM	2	2	Connect CR for OFF time setting when using the internal PWM method. Functions as the input pin for PWM signals when using the external PWM method.
REF	3	3	OUT pin (output MOSFET) for the internal PWM method Input pin for peak current setting Set a peak current based on the REF pin voltage.
SEN	4	4	Pin for detecting output current Connect the current detection resistor RS. Used for peak current detection and overcurrent detection when using the internal PWM method.
OUT	5	5,6	Pin connected to the load. Connected to the drain pin of the built-in MOSFET.
VBB	6	7	Main power input pin. Internal power is supplied from this pin via the internal regulator.
-	7	-	Pin removed LC52xxD (DIP8) has been removed to secure the insulating distance of the high voltage pins. For LC52xxS (SOP8), the design criteria of the customer must be considered.
GND	8	8	GND pin

Ta-Pd Characteristics

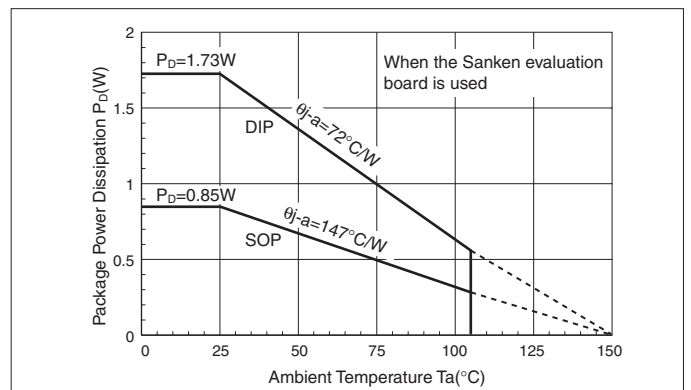

Block Diagram

If the pin number differs in the DIP8 and SOP8 packages, the pin number for SOP8 is indicated in parentheses.

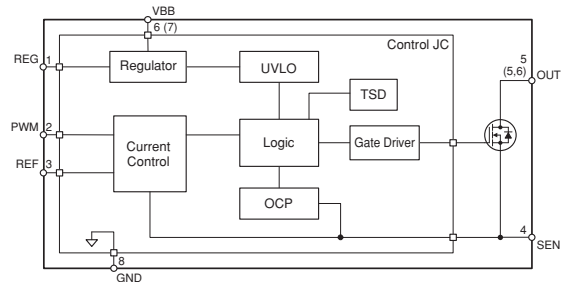

Typical Connection Diagram



LC5220 Series LED Driver ICs

Features

- Buck and buck-boost converter operations
- Built-in reference voltage for current setting
Realizes high precision and easy current setting
- SLEEP function
Output is latched to off when REF pin input voltage $\geq V_{SLP}$
- ENABLE function
All LED loads can be turned off by reducing REF pin input voltage
- High breakdown voltage supply input: 250V (MAX), 450V (MAX)
- Built-in constant current control circuit
Built-in PWM type constant current control circuit
Output current can be controlled by REF pin input voltage
- Supports external PWM dimming
- Protection functions
Flywheel diode open protection (OPP)
function...Latch shutdown
Undervoltage lockout function (UVLO)
Variable type overcurrent protection function (OCP)...Latch shutdown
Thermal shutdown function (TSD)...Auto restart

Applications

- LED light bulbs
- LED lighting equipment

Lineup

Part Number	Output Current	Input Voltage	R _{DS(ON)} (Max)	Package
LC5222D	0.5A	250V	2.2Ω	DIP8
LC5225D		450V	6.0Ω	
LC5222S		250V	2.2Ω	
LC5225S	1.0A	450V	6.0Ω	SOP8
LC5223D		250V	1.3Ω	
LC5226D		450V	3.0Ω	

Absolute Maximum Ratings

(T_a = 25°C)

Parameter	Symbol	Ratings					Unit	Remarks
		LC5222D	LC5222S	LC5225D	LC5225S	LC5223D		
Output Current*1	I _o	0.5		1.0			A	Excluding when t _w is less than 1μs
Main Supply Voltage	V _{BB}	250		450	250	450	V	
Output Breakdown Voltage	V _{O(BR)}	250		450	250	450	V	
PWM Pin Voltage*2	V _{PWM}	-0.3 to V _Z					V	
REF Pin Voltage*2	V _{REF}	-0.3 to V _Z					V	
SEN Pin Voltage	V _{SEN}	-0.3 to +4.0					V	Excluding when t _w is less than 1μs
Power Dissipation*3	P _D	1.73	0.85	1.73	0.85	1.73	W	Sanken Evaluation Board
Operating Ambient Temperature	T _a	-40 to +105					°C	
Storage Temperature	T _{stg}	-40 to +150					°C	
Junction Temperature	T _j	+150					°C	

*1: The output current value may be limited, depending on the duty ratio, ambient temperature, and heating conditions. Do not exceed the junction temperature T_j under any circumstances.

*2: There is a built-in zener diode between the PWM pin and GND. V_Z is the breakdown voltage of this internal zener diode, and V_Z = 6.3V (TYP). The maximum value of the inflow current is 1mA.

*3: The power dissipation P_D varies depending on the pattern layout of the circuit board used. Refer to the T_a-P_D characteristics curve.

Recommended Operating Conditions

Parameter	Symbol	Ratings								Unit
		LC5222D/S		LC5223D		LC5225D/S		LC5226D		
		min.	max.	min.	max.	min.	max.	min.	max.	
Supply Voltage	V _{BB}	25*1	200	25*1	200	25*1	400	25*1	400	V
Output Current (Average)	I _{O(AVG)}	—	0.4	—	0.8	—	0.4	—	0.8	A
REF Pin Voltage	V _{REF}	0.2	2.5	0.2	2.5	0.2	2.5	0.2	2.5	V
Case Temperature*2	T _c	—	105	—	105	—	105	—	105	°C

The recommended operating conditions show the operating conditions required to maintain normal circuit functions as shown in the electrical characteristics.

In actual operation, the device must be used within the recommended operating conditions.

*1: The minimum voltage depends on the LED used.

*2: Defined at the center of the package. The junction temperature T_j is assumed to be 150°C or lower.

Electrical Characteristics

(T_a = 25°C, V_{BB} = 140V, unless otherwise specified)

Parameter	Symbol	Measurement Conditions	Ratings			Unit	Remarks
			min.	typ.	max.		
Supply Current	I _{BBs}	When output is OFF	—	1	1.5	mA	
	I _{BB}	During operation	—	2.5	4	mA	
Output MOSFET Breakdown Voltage	V _{(BR)DSS}	I _D =1mA	250	—	—	V	LC5222D/S, LC5223D
			450	—	—	V	LC5225D/S, LC5226D
Output MOSFET ON Resistance	R _{DS(ON)}	I _D =0.5A	—	1.2	2.2	Ω	LC5222D/S
		I _D =1.0A	—	0.7	1.3	Ω	LC5223D
		I _D =0.5A	—	3.5	6	Ω	LC5225D/S
		I _D =1.0A	—	1.7	3	Ω	LC5226D
Output MOSFET Body Diode Forward Voltage	V _F	I _F =0.5A	—	0.8	1	V	LC5222D/S
		I _F =1.0A	—	0.75	1.2	V	LC5223D
		I _F =0.5A	—	0.8	0.9	V	LC5225D/S
		I _F =1.0A	—	0.88	1	V	LC5226D
UVLO Release Voltage	V _{UVLO(ON)}		—	14	—	V	V _{BB} pin voltage
UVLO Operation Voltage	V _{UVLO(OFF)}		—	12	—	V	V _{BB} pin voltage
REG Output Voltage	V _{REG}	I _{REG} =0mA	9.6	10	10.4	V	
REG Output Current	I _{REG}	V _{REG} =9V	-2	—	—	mA	
ENABLE Voltage	V _{ENB}		—	0.15	0.19	V	REF pin Voltage
SLEEP Voltage	V _{SLP}		2.85	3	—	V	REF pin Voltage
REF Pin Inflow Current	I _{REF}		-10	—	10	μA	
Current Control Detection Voltage	V _{SEN}	V _{REF} =0.2 to 2.0V	0.4×V _{REF} -0.03	0.4×V _{REF}	0.4×V _{REF} +0.03	V	
		V _{REF} =2.0 to 3.0V	0.77	0.8	0.83	V	
OCP Detection Voltage	V _{OCP}	V _{REF} =0.2 to 2.0V	—	0.4×V _{REF} +0.7	—	V	
		V _{REF} =2.0 to 3.0V	—	1.5	—	V	
SEN Pin Inflow Current	I _{SEN}		-10	—	10	μA	
PWM Pin Low Voltage	V _{PWM(L)}		—	2	—	V	
PWM Pin High Voltage	V _{PWM(H)}		—	3	—	V	
PWM Pin Output Current	I _{PWM}		—	-20	—	μA	
PWM Blanking Time	t _{BLK(P)}		—	0.3	—	μs	
OCP Blanking Time	t _{BLK(O)}		—	0.2	—	μs	
PWM Oscillation Frequency	f _{PWM}	Duty=50%	—	—	200	kHz	
PWM OFF Time	t _{OFF}	C _{PWM} =100pF	—	17	—	μs	
Output MOSFET Rising Time	t _r	I _o =0.4A	—	25	—	ns	
Output MOSFET Falling Time	t _f	I _o =0.4A	—	50	—	ns	
TSD Operating Temperature*	T _{TSD}		—	150	—	°C	
TSD Temperature Hysteresis*	T _{TSD(HYS)}		—	55	—	°C	
Thermal Resistance	θ _{ja}	Sanken Evaluation Board	—	—	72	°C/W	LC522xD
			—	—	147	°C/W	LC522xS

For the polarity of current values, the sink is defined as "positive" and the source is defined as "negative" with respect to the IC.
*: Control IC chip temperature (T_j)

External Dimensions

(Unit : mm)

LC522xD (DIP8)

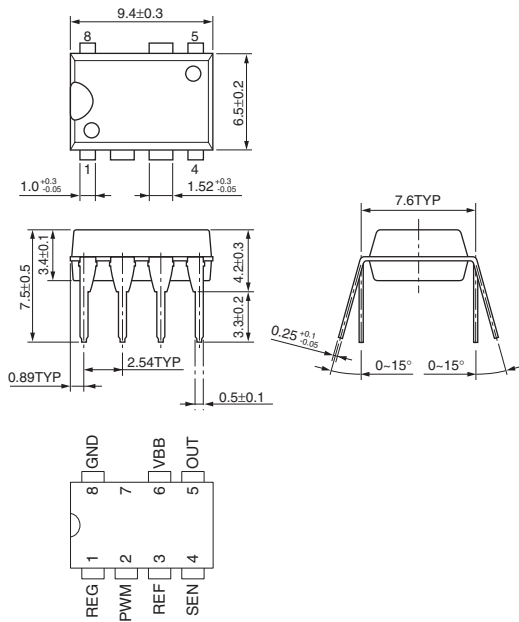

LC522xS (SOP8)

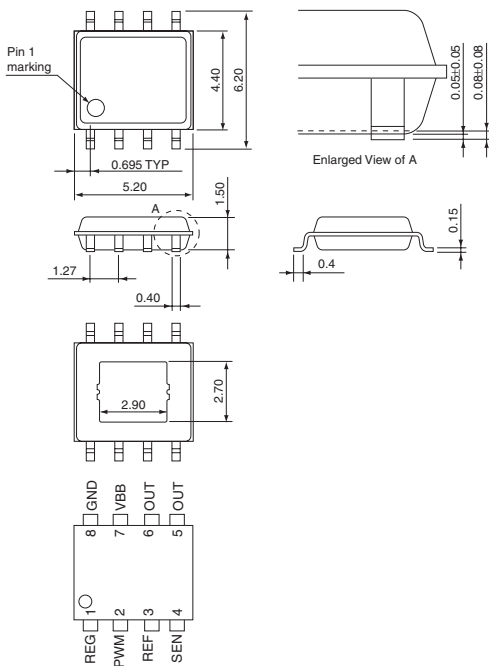

Pin Functions

Symbol	Pin No.		Function
	LC522xD (DIP8)	LC522xS (SOP8)	
REG	1	1	Output of the built-in regulator. Supplies current to the internal and external circuits. Connect a 0.1μF bypass capacitor near the pin.
PWM	2	2	Connect CR for OFF time setting when using the internal PWM method. Functions as the input pin for PWM signals when using the external PWM method.
REF	3	3	Input pin for OUT pin (output MOSFET) peak current setting when using the internal PWM method. Set a peak current based on the REF pin voltage. Also, signal input pin for turning the OUT pin (ENABLE function) on and off, and latching the OUT pin to off (SLEEP function).
SEN	4	4	Pin for detecting output current. For internal PWM, connect a detection resistor. Used as a peak current detection and overcurrent detection pin.
OUT	5	5,6	Pin connected to the load. Connected to the drain pin of the built-in output MOSFET.
VBB	6	7	Main power input pin. Internal power is supplied from this pin via the internal regulator.
-	7	-	Pin removed. LC52xD (DIP8) has been removed to secure the insulating distance of the high voltage pins. For LC52xS (SOP8), the design criteria of the customer must be considered.
GND	8	8	GND pin

Ta-Pd Characteristics

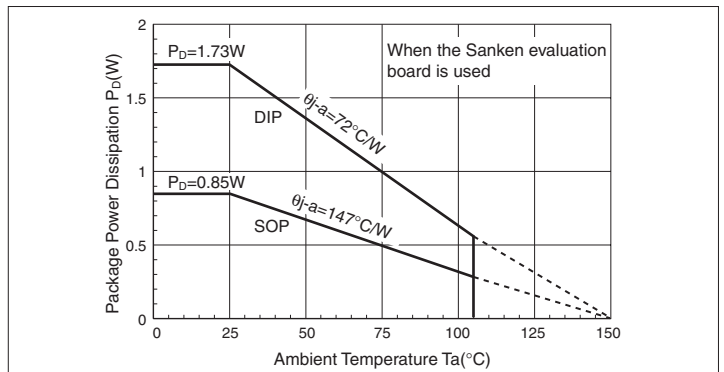

Block Diagram

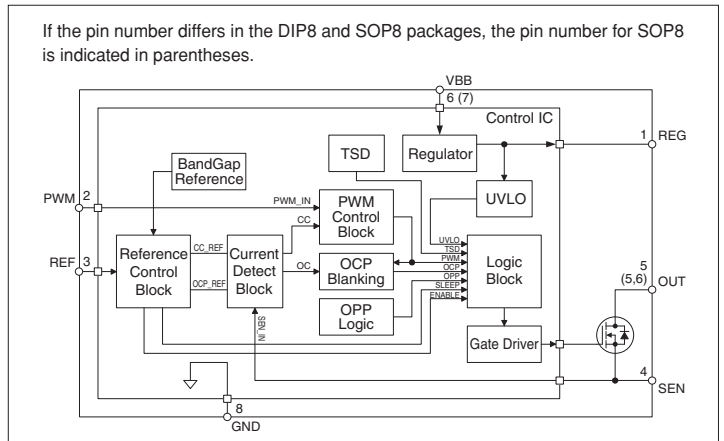

Typical Connection Diagram

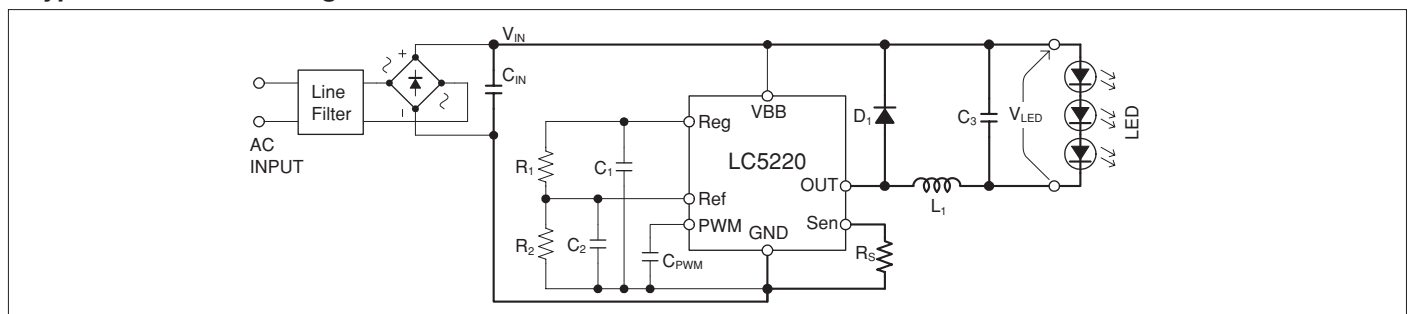

LC5550 Series High Efficiency, High Power Factor LED Driver ICs

Features

- Buck converter operations
- Supports PWM type and Quasi-resonant type control
- Built-in ON time control circuit
(Average current control enables high power factor)
- Built-in soft start function
(Reduces load on power MOSFET and secondary side rectifier diodes at power-on)
- Built-in bias assist function
(Improves startup, suppresses VCC voltage drop during operation, lowers capacitance of VCC capacitor, and enables backup of the control circuit supply by using a ceramic capacitor)
- Built-in leading edge blanking function
- Built-in maximum ON time control circuit
- Protection function
Overcurrent protection (OCP)...Pulse by pulse
Overvoltage protection (OVP)...Latch shutdown
Overload protection (OLP)...Latch shutdown
Thermal shutdown (TSD)...Latch shutdown

Lineup

Part Number	MOSFET		PWM Oscillation Frequency f_{osc} (TYP)	Maximum ON Time $t_{ON(MAX)}$ (TYP)	P_{OUT}^* AC230V / Universal
	V_{DSS} (MIN)	$R_{DS(ON)}$ (MAX)			
LC5555LD	650V	3.95 Ω	72kHz	9.3 μ s	13W / 10W
LC5556LD		1.9 Ω	60kHz	11.2 μ s	20W / 16W

*: The output power values are based on the rated temperature. Output at 120 to 140% of the rated temperature is possible for the maximum output power. Note, however, that the output power may be limited by a low output voltage and by the ON duty specified during transformer design.

Absolute Maximum Ratings

(T_a = 25°C)

Parameter	Symbol	Ratings		Unit	Remarks
		LC5555D	LC5556D		
Drain Current	I_{DPEAK}	2.5	4.0	A	
Avalanche Energy Capacity	E_{AS}	47 ($I_{LPEAK}=2.0A$)	86 ($I_{LPEAK}=2.7A$)	mJ	
Control Supply Voltage	V_{CC}	35		V	
OCP Pin Voltage	V_{OCP}	-2.0 to +5.0		V	
COMP Pin Voltage	V_{COMP}	-0.3 to +7.0		V	
ISENSE Pin Voltage	V_{SEN}	-0.3 to +5.0		V	
MOSFET Power Dissipation	P_D	0.97		W	Board size when mounted on board 15mm×15mm
Operating Ambient Temperature	T_{op}	-55 to +125		°C	
Storage Temperature	T_{stg}	-55 to +125		°C	
Channel Temperature	T_{ch}	150		°C	

Applications

- LED light bulbs
- LED lighting equipment

Electrical Characteristics

(T_a = 25°C, V_{CC} = 20V, unless otherwise specified)

Parameter	Symbol	Ratings			Unit	Remarks
		min.	typ.	max.		

Power Supply Startup Operation

Operation Startup Voltage	$V_{CC(ON)}$	13.8	15.1	17.3	V	
Operation Stop Voltage	$V_{CC(OFF)}$	8.4	9.4	10.7	V	
Circuit Current During Operation	$I_{CC(ON)}$	–	–	4.7	mA	
Startup Circuit Operation Voltage	$V_{STARTUP}$	18	21	24	V	
Startup Current	$I_{CC(STARTUP)}$	–8.5	–4.0	–1.5	mA	V _{CC} =13V
Startup Current Supply Threshold Voltage	$V_{CC(BIAS)}$	9.5	11	12.5	V	

Normal Operation

PWM Oscillation Frequency	f_{osc}	60	72	84	kHz	LC5555LD
		50	60	70		LC5556LD
Maximum ON Time	$t_{ON(MAX)}$	8.0	9.3	11.2	μ s	LC5555LD
		9.0	11.2	13.4		LC5556LD
COMP Pin Control Lower Voltage	$V_{COMP(MIN)}$	0.30	0.55	0.80	V	
Error Amplifier Reference Voltage	$V_{SEN(TH)}$	–0.21	–0.2	–0.19	V	
Error Amplifier Source Current	$I_{SEN(SOURCE)}$	–36	–24	–12	μ A	
Error Amplifier Sink Current	$I_{SEN(SINK)}$	12	24	36	μ A	
Leading Edge Blanking Time	$t_{ON(LEB)}$	–	600	–	ns	
Quasi-Resonant Operation Threshold Voltage 1	$V_{BD(TH1)}$	0.14	0.24	0.34	V	
Quasi-Resonant Operation Threshold Voltage 2	$V_{BD(TH2)}$	0.11	0.16	0.21	V	

Protection Operation

Overcurrent Detection Threshold Voltage	V_{OCP}	–0.92	–0.8	–0.68	V	
OCP Pin Outflow Current	I_{OCP}	–120	–40	–10	μ A	
OCP Pin OVP Threshold Voltage	$V_{BD(OVP)}$	2.2	2.6	3.0	V	
OLP Threshold Voltage	$V_{COMP(OLP)}$	4.1	4.5	4.9	V	
VCC Pin OVP Threshold Voltage	$V_{CC(OVP)}$	28.5	31.5	34.0	V	
TSD Operating Temperature	$T_{J(TSD)}$	135	–	–	°C	

MOSFET

Drain-Source Voltage	V_{DSS}	650	–	–	V	
Drain Leakage Current	I_{DSS}	–	–	300	μ A	
ON Resistance	$R_{DS(ON)}$	–	–	3.95	Ω	LC5555D
		–	–	1.9		LC5556D
Switching Time	t_t	–	–	250	ns	LC5555D
		–	–	400		LC5556D
Thermal Resistance	θ_{ch-c}	–	–	42	°C/W	LC5555D
		–	–	35.5		LC5556D

For the polarity of current values, the sink is defined as "positive" and the source is defined as "negative" with respect to the IC.

External Dimensions (DIP8)

(Unit : mm)

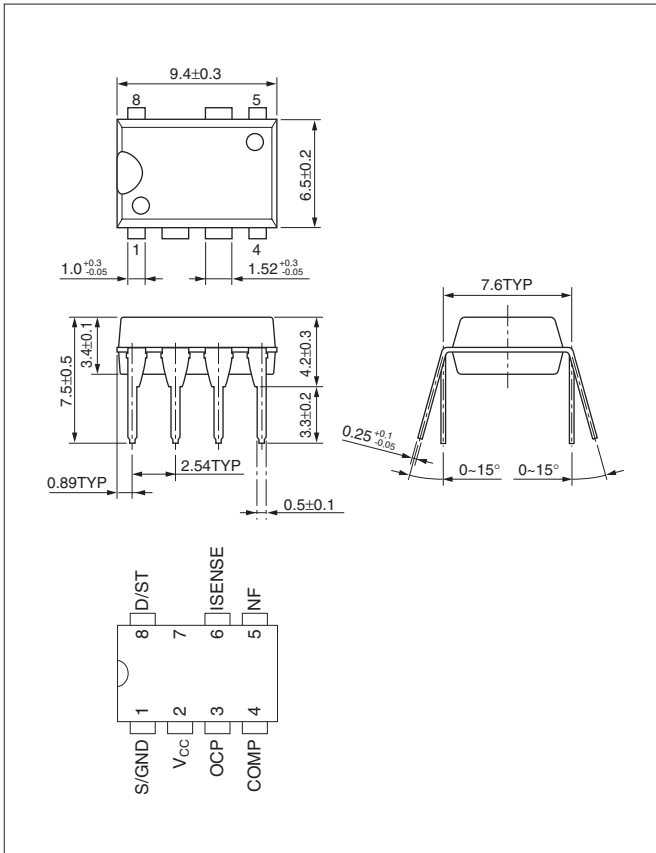

Pin Functions

Pin No.	Symbol	Function
1	S/GND	MOSFET source and GND for control
2	V _{CC}	Control circuit power input and Overvoltage protection signal input
3	OCP	Overcurrent protection and Quasi-resonant signal input and Overvoltage protection signal input
4	COMP	Feedback phase compensation
5	NF	(No function*)
6	ISENSE	Feedback current detection
7	-	(Pin removed)
8	D/ST	MOSFET drain and Startup current input

*: NF (pin 5) connects to the stable potential S/GND pattern (pin 1 potential) via the shortest distance for stable operation.

Block Diagram

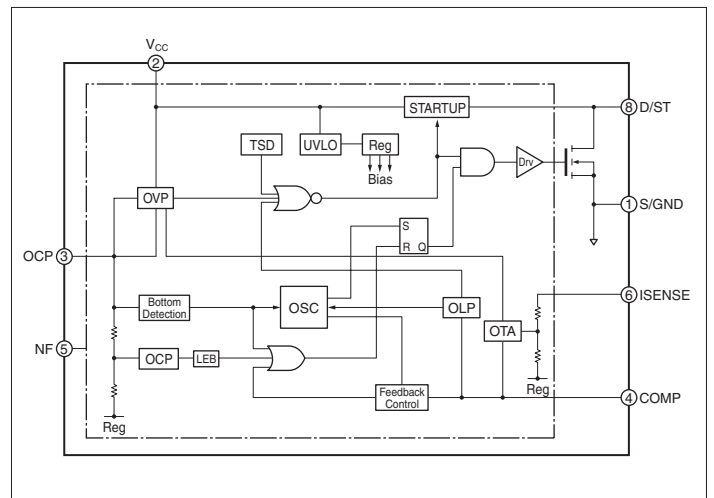

Typical Connection Diagram



LC5510 Series LED Driver ICs with Harmonics Standard (ICE61000-3-2 Class C) at all load condition

■Features

- Non-isolated type
- Built-in ON time control circuit
(Average current control enables high power factor)
- Built-in soft start function
(Reduces load on power MOSFET and secondary side rectifier diodes at power-on)
- Built-in bias assist function
(Improves startup, suppresses VCC voltage drop during operation, lowers capacitance of VCC capacitor, and enables backup of the control circuit supply by using a ceramic capacitor)
- Built-in leading edge blanking function
- Built-in maximum ON time control circuit
- Protection function
Overcurrent protection (OCP)...Pulse by pulse
Overvoltage protection (OVP)...Auto restart
Overload protection (OLP)...Auto restart
Thermal shutdown (TSD)...Latch shutdown

■Lineup

Part Number	MOSFET		P _{OUT} * AC230V / Universal
	V _{DSS} (MIN)	R _{DS(ON)} (MAX)	
LC5511D	650V	3.95Ω	13W / 10W
LC5513D		1.9Ω	20W / 16W

*: The output power values are based on the rated temperature. Output at 120 to 140% of the rated temperature is possible for the maximum output power. Note, however, that the output power may be limited by a low output voltage and by the ON duty specified during transformer design.

■Absolute Maximum Ratings

(T_a = 25°C)

Parameter	Symbol	Ratings		Unit	Remarks
		LC5511D	LC5513D		
Drain Current	I _{DPEAK}	2.5	4.0	A	Single Pulse
Avalanche Energy Capacity	E _{AS}	47 (I _{LPEAK} =2.0A)	86 (I _{LPEAK} =2.7A)	mJ	Single Pulse, V _{DD} =99V, L=20mH
Control Supply Voltage	V _{CC}	35		V	
OCP Pin Voltage	V _{OCP}	-2.0 to +5.0		V	
COMP Pin Voltage	V _{COMP}	-0.3 to +7.0		V	
ISENSE Pin Voltage	V _{SEN}	-0.3 to +5.0		V	
MOSFET Power Dissipation	P _D	0.97		W	Board size when mounted on board 15mm×15mm
Operating Ambient Temperature	T _{OP}	-55 to +125		°C	
Storage Temperature	T _{STG}	-55 to +125		°C	
Channel Temperature	T _{CH}	150		°C	

■Applications

- LED light bulbs
- LED lighting equipment

■Electrical Characteristics

(T_a = 25°C, V_{CC} = 20V, unless otherwise specified)

Parameter	Symbol	Ratings			Unit	Remarks
		min.	typ.	max.		

Power Supply Startup Operation

Operation Startup Voltage	V _{CC(ON)}	13.8	15.1	17.3	V	
Operation Stop Voltage*1	V _{CC(OFF)}	8.4	9.4	10.7	V	
Circuit Current During Operation	I _{CC(ON)}	–	–	3.7	mA	
Startup Circuit Operation Voltage	V _{STARTUP}	42	57	72	V	
Startup Current	I _{CC(STARTUP)}	–5.5	–3.0	–1.0	mA	V _{CC} =13V
Startup Current Supply Threshold Voltage 1*1	V _{CC(BIAS)1}	9.5	11	12.5	V	
Startup Current Supply Threshold Voltage 2	V _{CC(BIAS)2}	14.4	16.6	18.8	V	

Normal Operation

PWM Oscillation Frequency	f _{OSC}	11.0	14.0	18.0	kHz	
Maximum ON Time	t _{ON(MAX)}	30.0	40.0	50.0	μs	
COMP Pin Control Lower Voltage	V _{COMP(MIN)}	0.55	0.90	1.25	V	
Error Amplifier Reference Voltage	V _{SEN(TH)}	0.27	0.30	0.33	V	
Error Amplifier Source Current	I _{SEN(SOURCE)}	–11	–7	–3	μA	
Error Amplifier Sink Current	I _{SEN(SINK)}	3	7	11	μA	
Leading Edge Blanking Time	t _{ON(LEB)}	–	500	–	ns	
Quasi-Resonant Operation Threshold Voltage 1	V _{BD(TH1)}	0.14	0.24	0.34	V	
Quasi-Resonant Operation Threshold Voltage 2	V _{BD(TH2)}	0.12	0.17	0.22	V	

Protection Operation

Overcurrent Detection Threshold Voltage	V _{OCP}	–0.66	–0.60	–0.54	V	
OCP Pin Outflow Current	I _{OCP}	–120	–40	–10	μA	
OCP Pin OVP Threshold Voltage	V _{BD(OVP)}	2.2	2.6	3.0	V	
OLP Threshold Voltage	V _{COMP(OLP)}	4.1	4.5	4.9	V	
VCC Pin OVP Threshold Voltage	V _{CC(OVP)}	28.5	31.5	34.0	V	
TSD Operating Temperature	T _{J(TSD)}	135	–	–	°C	

MOSFET

Drain-Source Voltage	V _{DSS}	650	–	–	V	
Drain Leakage Current	I _{DSS}	–	–	300	μA	
ON Resistance	R _{DS(ON)}	–	–	3.95	Ω	LC5511D
		–	–	1.9		LC5513D
Switching Time	t _f	–	–	250	ns	LC5511D
		–	–	400		LC5513D
Thermal Resistance*2	θ _{ch-c}	–	–	42	°C/W	LC5511D
		–	–	35.5		LC5513D

For the polarity of current values, the sink is defined as "positive" and the source is defined as "negative" with respect to the IC.

*1: The relationship V_{CC(BIAS)1} > V_{CC(OFF)} holds true for all products.

*2: Thermal resistance between the MOSFET channel and the case. The case temperature T_c is determined by the temperature at the center of the marking surface.

External Dimensions (DIP8)

(Unit : mm)



Pin Functions

Pin No.	Symbol	Function
1	S/GND	MOSFET source and GND for control
2	Vcc	Control circuit power input and Overvoltage protection signal input
3	OCP	Overcurrent protection and Quasi-resonant signal input and Overvoltage protection signal input
4	COMP	Feedback phase compensation
5	NF	(No function*)
6	ISENSE	Feedback current detection and Overvoltage protection signal input
7	-	(Pin removed)
8	D/ST	MOSFET drain and Startup current input

*: NF (pin 5) connects to the stable potential S/GND pattern (pin 1 potential) via the shortest distance for stable operation.

Block Diagram

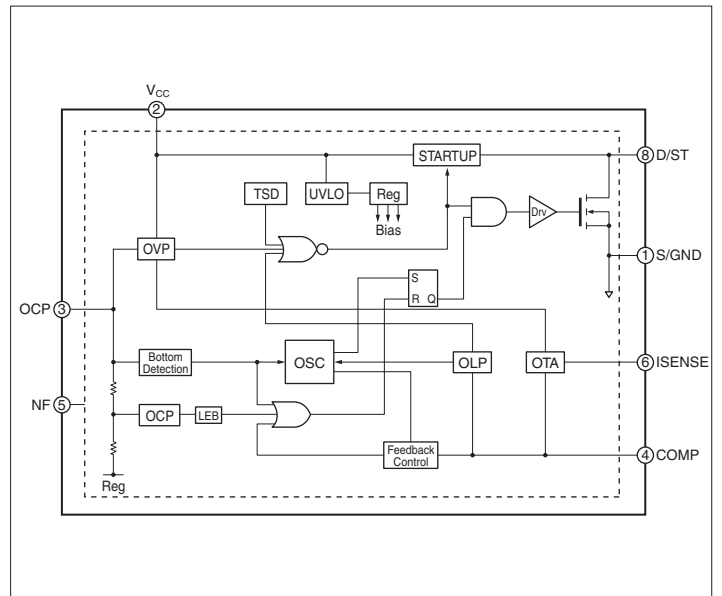

Typical Connection Diagram

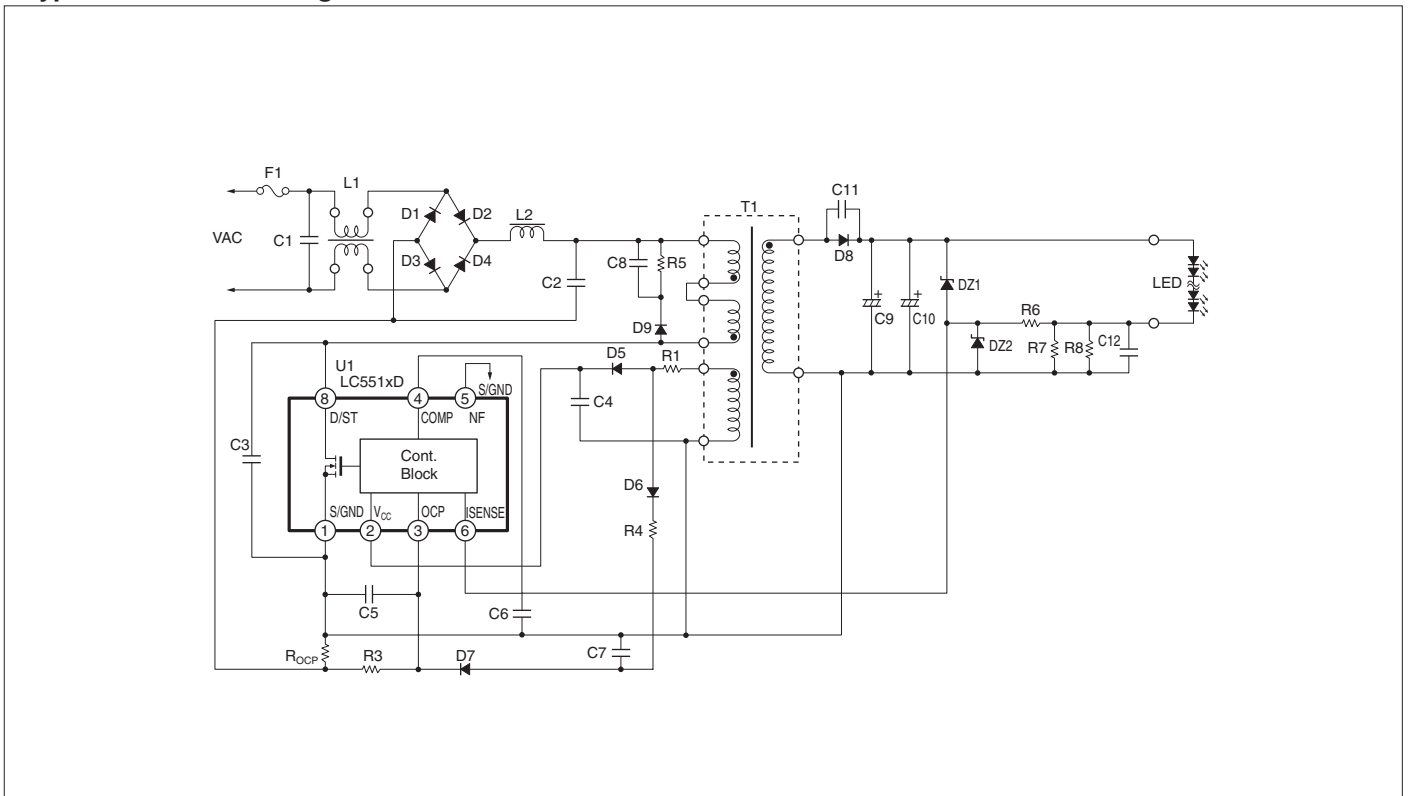

LC5560 Series High Power Factor LED Driver ICs with Harmonics Standard (ICE61000-3-2 Class C) at all load condition

Features

- Non-isolated type
- Built-in ON time control circuit
(Average current control enables high power factor)
- Built-in soft start function
(Reduces load on power MOSFET and secondary side rectifier diodes at power-on)
- Built-in bias assist function
(Improves startup, suppresses VCC voltage drop during operation, lowers capacitance of VCC capacitor, and enables backup of the control circuit supply by using a ceramic capacitor)
- Built-in leading edge blanking function
- Built-in maximum ON time control circuit
- Protection function
Overcurrent protection (OCP)...Pulse by pulse
Overvoltage protection (OVP)...Latch shutdown
Overload protection (OLP)...Latch shutdown
Thermal shutdown (TSD)...Latch shutdown

Lineup

Part Number	MOSFET		PWM Oscillation Frequency f_{osc} (TYP)	Maximum ON Time $t_{ON(MAX)}$ (TYP)	P_{OUT}^* AC230V / Universal
	V_{DSS} (MIN)	$R_{DS(ON)}$ (MAX)			
LC5565LD	650V	3.95 Ω	72kHz	9.3 μ s	13W / 10W
LC5566LD		1.9 Ω	60kHz	11.2 μ s	20W / 16W

*: The output power values are based on the rated temperature. Output at 120 to 140% of the rated temperature is possible for the maximum output power. Note, however, that the output power may be limited by a low output voltage and by the ON duty specified during transformer design.

Absolute Maximum Ratings

(Ta = 25°C)

Parameter	Symbol	Ratings		Unit	Remarks
		LC5565LD	LC5566LD		
Drain Current	I_{DPEAK}	2.5	4.0	A	Single Pulse
Avalanche Energy Capacity	EAS	47 ($I_{LPEAK}=2.0A$)	86 ($I_{LPEAK}=2.7A$)	mJ	Single Pulse, $V_{DD}=99V$, $L=20mH$
Control Supply Voltage	V_{CC}	35		V	
OCP Pin Voltage	V_{OCP}	-2.0 to +5.0		V	
COMP Pin Voltage	V_{COMP}	-0.3 to +7.0		V	
V_{REF} Pin Voltage	V_{REF}	-0.3 to +5.0		V	
ISENSE Pin Voltage	V_{SEN}	-0.3 to +5.0		V	
MOSFET Power Dissipation	P_D	0.97		W	Board size when mounted on board 15mm \times 15mm
Operating Ambient Temperature	Top	-55 to +125		°C	
Storage Temperature	Tstg	-55 to +125		°C	
Channel Temperature	Tch	150		°C	

Applications

- LED light bulbs
- LED lighting equipment

Electrical Characteristics

(Ta = 25°C, Vcc = 20V, unless otherwise specified)

Parameter	Symbol	Ratings			Unit	Remarks
		min.	typ.	max.		

Power Supply Startup Operation

Operation Startup Voltage	$V_{CC(ON)}$	13.8	15.1	17.3	V	
Operation Stop Voltage*1	$V_{CC(OFF)}$	8.4	9.4	10.7	V	
Circuit Current During Operation	$I_{CC(ON)}$	-	-	4.7	mA	
Startup Circuit Operation Voltage	$V_{STARTUP}$	18	21	24	V	
Startup Current	$I_{CC(STARTUP)}$	-8.5	-4.0	-1.5	mA	$V_{CC}=13V$
Startup Current Supply Threshold Voltage*1	$V_{CC(BIAS)}$	9.5	11.0	12.5	V	

Normal Operation

PWM Oscillation Frequency	f_{osc}	60	72	84	kHz	LC5565LD
		50	60	70		LC5566LD
Maximum ON Time	$t_{ON(MAX)}$	8.0	9.3	11.2	μ s	LC5565LD
		9.0	11.2	13.4		LC5566LD
COMP Pin Control Lower Voltage	$V_{COMP(MIN)}$	0.30	0.55	0.80	V	
Error Amplifier Reference Voltage	$V_{SEN(TH)}$	0.312	0.335	0.358	V	
Error Amplifier Source Current	$I_{SEN(SOURCE)}$	-22	-14	-6	μ A	
Error Amplifier Sink Current	$I_{SEN(SINK)}$	6	14	22	μ A	
Leading Edge Blanking Time	$t_{ON(LEB)}$	-	600	-	ns	
Quasi-Resonant Operation Threshold Voltage 1	$V_{BD(TH1)}$	0.14	0.24	0.34	V	
Quasi-Resonant Operation Threshold Voltage 2	$V_{BD(TH2)}$	0.11	0.16	0.21	V	

Protection Operation

Overcurrent Detection Threshold Voltage	V_{OCP}	-0.66	-0.60	-0.54	V	
OCP Pin Outflow Current	I_{OCP}	-120	-40	-10	μ A	
OCP Pin OVP Threshold Voltage	$V_{BD(OVP)}$	2.2	2.6	3.0	V	
OLP Threshold Voltage	$V_{COMP(OLP)}$	4.1	4.5	4.9	V	
VCC Pin OVP Threshold Voltage	$V_{CC(OVP)}$	28.5	31.5	34.0	V	
TSD Operating Temperature	$T_{j(TSD)}$	135	-	-	°C	

MOSFET

ON Resistance	$R_{DS(ON)}$	-	-	3.95	Ω	LC5565LD
		-	-	1.9		LC5566LD
Switching Time	t_f	-	-	250	ns	LC5565LD
		-	-	400		LC5566LD
Thermal Resistance*2	θ_{ch-c}	-	-	42	°C/W	LC5565LD
		-	-	35.5		LC5566LD

For the polarity of current values, the sink is defined as "positive" and the source is defined as "negative" with respect to the IC.

*1: The relationship $V_{CC(BIAS)1} > V_{CC(OFF)}$ holds true for all products.

*2: Thermal resistance between the MOSFET channel and the case. The case temperature T_c is determined by the temperature at the center of the marking surface.

External Dimensions (DIP8)

(Unit : mm)



Pin Functions

Pin No.	Symbol	Function
1	S/GND	MOSFET source and GND for control
2	Vcc	Control circuit power input and Overvoltage protection signal input
3	OCP	Overcurrent protection and Quasi-resonant signal input and Overvoltage protection signal input
4	COMP	Feedback phase compensation
5	VREF	Dimmer signal input
6	ISENSE	Feedback current detection and Overvoltage protection signal input
7	-	(Pin removed)
8	D/ST	MOSFET drain and Startup current input

Block Diagram

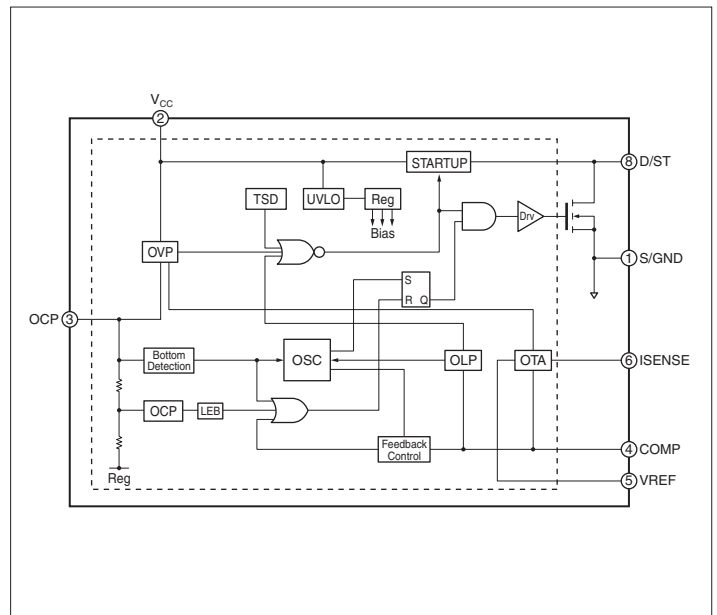

Typical Connection Diagram

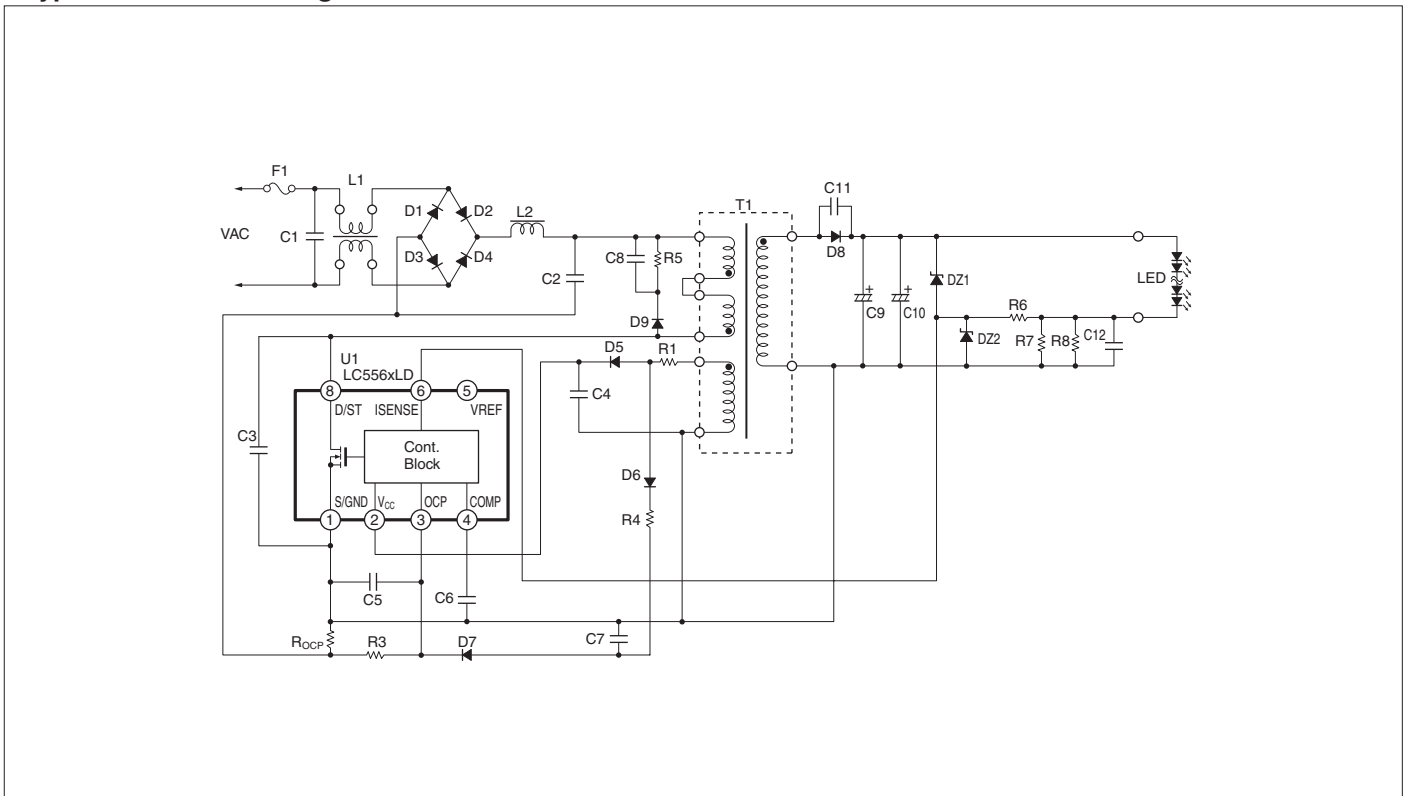

LC5520 Series LED Driver ICs with Harmonics Standard (ICE61000-3-2 Class C) at all load condition

■Features

- Isolated type
- Built-in ON time control circuit
(Average current control enables high power factor)
- Built-in soft start function
(Reduces load on power MOSFET and secondary side rectifier diodes at power-on)
- Built-in bias assist function
(Improves startup, suppresses VCC voltage drop during operation, lowers capacitance of VCC capacitor, and enables backup of the control circuit supply by using a ceramic capacitor)
- Built-in leading edge blanking function
- Built-in maximum ON time control circuit
- Protection function
Overcurrent protection (OCP)...Pulse by pulse
Overvoltage protection (OVP)...Auto restart
Overload protection (OLP)...Auto restart
Thermal shutdown (TSD)...Latch shutdown

■Applications

- LED light bulbs
- LED lighting equipment

■Lineup

Part Number	MOSFET		P _{out} * AC230V / Universal	Package
	V _{DSS} (MIN)	R _{DS(ON)} (MAX)		
LC5521D	650V	3.95Ω	13W / 10W	DIP8
LC5523D		1.9Ω		
LC5523F	650V	1.9Ω	60W / 40W	TO220F-7
LC5525F		1.1Ω		

*: The output power values are based on the rated temperature. Output at 120 to 140% of the rated temperature is possible for the maximum output power. Note, however, that the output power may be limited by a low output voltage and by the ON duty specified during transformer design.

■Absolute Maximum Ratings

(T_a = 25°C)

Parameter	Symbol	Ratings				Unit	Remarks
		LC5521D	LC5523D	LC5523F	LC5525F		
Drain Current	I _{DPEAK}	2.5	4.0	9.2	13.0	A	Single Pulse
Avalanche Energy Capacity	E _{AS}	47 (I _{LPEAK} =2.0A)	86 (I _{LPEAK} =2.7A)	99 (I _{LPEAK} =2.9A)	233 (I _{LPEAK} =4.4A)	mJ	Single Pulse, V _{DD} =99V, L=20mH
Control Supply Voltage	V _{CC}	35				V	
OCP Pin Voltage	V _{OCP}	-2.0 to +5.0				V	
FB Pin Voltage	V _{FB}	-0.3 to +7.0				V	
OVP Pin Voltage	V _{OVP}	-0.3 to +5.0				V	
MOSFET Power Dissipation	P _D	0.97		1.8		W	
	P _{D2}	-		20.2	23.6	W	With infinite heatsink
Operating Ambient Temperature	T _{OP}	-55 to +125				°C	
Storage Temperature	T _{STG}	-55 to +125				°C	
Channel Temperature	T _{CH}	150				°C	

■Electrical Characteristics

(T_a = 25°C, V_{CC} = 20V, unless otherwise specified)

Parameter	Symbol	Ratings			Unit	Remarks
		min.	typ.	max.		

Power Supply Startup Operation

Operation Startup Voltage	V _{CC(ON)}	13.8	15.1	17.3	V	
Operation Stop Voltage*1	V _{CC(OFF)}	8.4	9.4	10.7	V	
Circuit Current During Operation	I _{CC(ON)}	-	-	3.7	mA	
Startup Circuit Operation Voltage	V _{STARTUP}	42	57	72	V	
Startup Current	I _{CC(STARTUP)}	-5.5	-3.0	-1.0	mA	V _{CC} =13V
Startup Current Supply Threshold Voltage*1	V _{CC(BIAS)}	9.5	11.0	12.5	V	

Normal Operation

PWM Oscillation Frequency	f _{OSC}	11.0	14.0	18.0	kHz	
Maximum ON Time	t _{ON(MAX)}	30.0	40.0	50.0	μs	
FB Pin Control Lower Voltage	V _{FB(MIN)}	0.55	0.90	1.25	V	
Maximum Feedback Current	I _{FB(MAX)}	-40	-25	-10	μA	
Leading Edge Blanking Time	t _{ON(LEB)}	-	500	-	ns	
Quasi-Resonant Operation Threshold Voltage 1	V _{BD(TH1)}	0.14	0.24	0.34	V	
Quasi-Resonant Operation Threshold Voltage 2	V _{BD(TH2)}	0.12	0.17	0.22	V	

Protection Operation

Overcurrent Detection Threshold Voltage	V _{OCP}	-0.66	-0.60	-0.54	V	
OCP Pin Outflow Current	I _{OCP}	-120	-40	-10	μA	
OCP Pin OVP Threshold Voltage	V _{BD(OVP)}	2.2	2.6	3.0	V	
OLP Threshold Voltage	V _{COMP(OLP) 1}	5.0	5.5	6.0	V	
	V _{COMP(OLP) 2}	4.1	4.5	4.9		
OVP Pin OVP Threshold Voltage	V _{OVP(OVP)}	1.6	2.0	2.4	V	
VCC Pin OVP Threshold Voltage	V _{CC(OVP)}	28.5	31.5	34.0	V	
TSD Operating Temperature	T _{I(TSD)}	135	-	-	°C	

MOSFET

Drain-Source Voltage	V _{DSS}	650	-	-	V	
Drain Leakage Current	I _{DSS}	-	-	300	μA	
ON Resistance	R _{DS(ON)}	-	-	3.95	Ω	LC5521D
		-	-	1.9		LC5523D
		-	-	1.9		LC5523F
		-	-	1.1		LC5535F
Switching Time	t _t	-	-	250	ns	LC5521D
		-	-	400		LC5523D
		-	-	400		LC5523F
		-	-	400		LC5535F
Thermal Resistance*2	θ _{ch-c}	-	-	42	°C/W	LC5521D
		-	-	35.5		LC5523D
		-	-	3.1		LC5523F
		-	-	2.2		LC5535F

For the polarity of current values, the sink is defined as "positive" and the source is defined as "negative" with respect to the IC.

*1: The relationship V_{CC(BIAS) 1} > V_{CC(OFF)} holds true for all products.

*2: Thermal resistance between the MOSFET channel and the case. The case temperature T_c is determined by the temperature at the center of the marking surface.

External Dimensions

(Unit : mm)

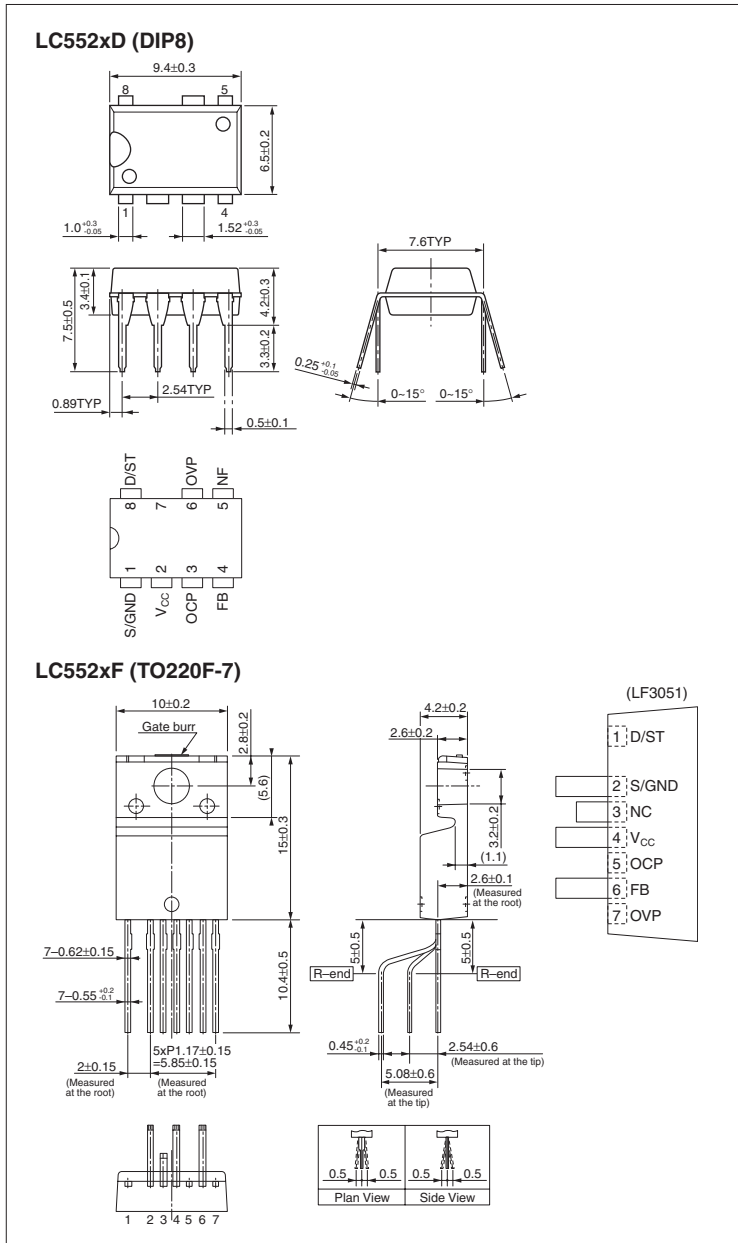

Pin Functions

LC552xD (DIP8)

Pin No.	Symbol	Function
1	S/GND	MOSFET source and GND for control
2	Vcc	Control circuit power input and Overvoltage protection signal input
3	OCP	Overcurrent protection and Quasi-resonant signal input and Overvoltage protection signal input
4	FB	Feedback signal input and Overload protection signal input
5	NF	(No function*)
6	OVP	Overvoltage protection signal input
7	-	(Pin removed)
8	D/ST	MOSFET drain and Startup current input

*: NF (pin 5) connects to the stable potential S/GND pattern (pin 1 potential) via the shortest distance for stable operation.

LC552xF (TO220F-7)

Pin No.	Symbol	Function
1	D/ST	MOSFET drain and Startup current input
2	S/GND	MOSFET source and GND for control
3	NC	-
4	Vcc	Control circuit power input and Overvoltage protection signal input
5	OCP	Overcurrent protection and Quasi-resonant signal input and Overvoltage protection signal input
6	FB	Feedback signal input and Overload protection signal input
7	OVP	Overvoltage protection signal input

Block Diagram

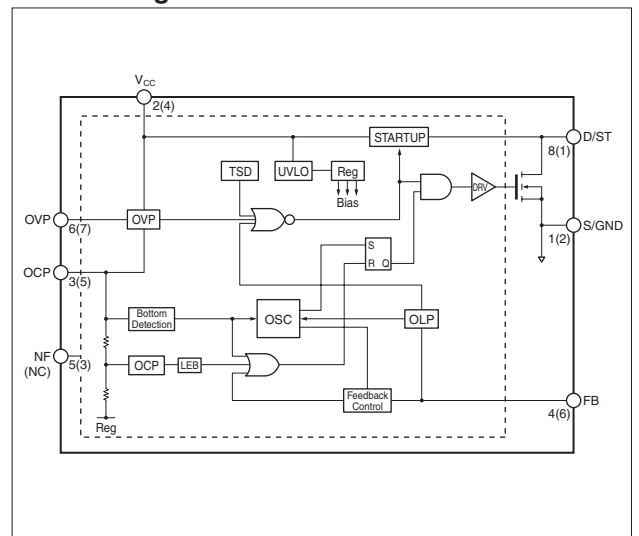

Typical Connection Diagram

The pin number for DIP8 is indicated. The pin number for TO220F-7 is indicated in parentheses.

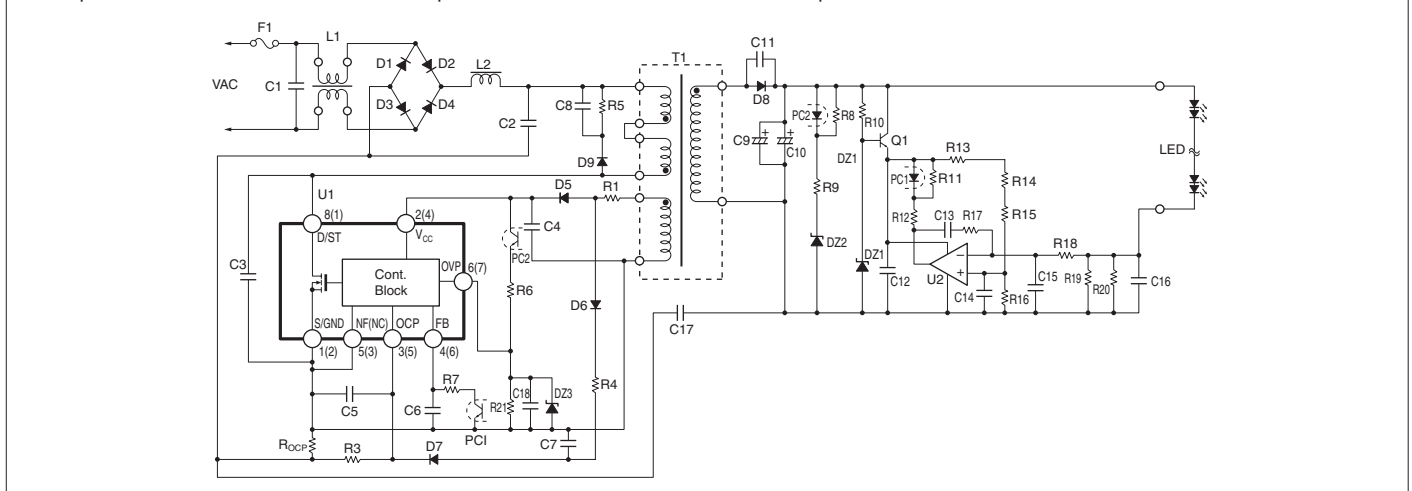

LC5540 Series LED Driver ICs with Harmonics Standard (ICE61000-3-2 Class C) at all load conditon

Features

- Isolated type
- Built-in ON time control circuit (Average current control enables high power factor)
- Built-in soft start function (Reduces load on power MOSFET and secondary side rectifier diodes at power-on)
- Built-in bias assist function (Improves startup, suppresses VCC voltage drop during operation, lowers capacitance of VCC capacitor, and enables backup of the control circuit supply by using a ceramic capacitor)
- Built-in leading edge blanking function
- Built-in maximum ON time control circuit
- Avalanche energy capacity guaranteed (Enables simplification of the surge absorption circuit.)
- Protection function
Overcurrent protection (OCP)...Pulse by pulse
Overvoltage protection (OVP)...Latch shutdown
Overload protection (OLP)...Latch shutdown
Thermal shutdown (TSD)...Latch shutdown

Applications

- LED light bulbs
- LED lighting equipment

Lineup

Part Number	MOSFET		PWM Oscillation Frequency fosc (TYP)	Maximum ON Time ton(MAX) (TYP)	Pout* AC230V / Universal	Package
	Vdss (MIN)	Rds(ON) (MAX)				
LC5545LD	650V	3.95Ω	72kHz	9.3μs	13W / 10W	DIP8
LC5546LD		1.9Ω	60kHz			
LC5548LD	800V	3.5Ω	72kHz	9.3μs	13W / 10W	
LC5546LF	650V	1.9Ω	40kHz	17.5μs	60W / 40W	TO220F-7
LC5547LF		1.1Ω			80W / 55W	
LC5549LF	800V	1.7Ω			60W / 40W	

*: The output power values are based on the rated temperature. Output at 120 to 140% of the rated temperature is possible for the maximum output power. Note, however, that the output power may be limited by a low output voltage and by the ON duty specified during transformer design.

Absolute Maximum Ratings

(Ta = 25°C)

Parameter	Symbol	Ratings					Unit	Remarks	
		LC5545LD	LC5546LD	LC5548LD	LC5546LF	LC5547LF			LC5549LF
Drain Current	IDPEAK	2.5	4.0	2.6	9.2	13.0	10.5	A	Single Pulse
Avalanche Energy Capacity	EAS	47 (ILPEAK=2.0A)	86 (ILPEAK=2.7A)	56 (ILPEAK=2.3A)	99 (ILPEAK=2.9A)	233 (ILPEAK=4.4A)	92 (ILPEAK=2.8A)	mJ	Single Pulse, VDD=99V, L=20mH
Control Supply Voltage	VCC	35					V		
OCP Pin Voltage	VOCP	-2.0 to +5.0					V		
FB Pin Voltage	VFB	-0.3 to +7.0					V		
OVP Pin Voltage	VOVP	-0.3 to +5.0					V		
MOSFET Power Dissipation	PD	0.97		1.8			W		
	PD2	-		20.2	23.6		W	With infinite heatsink	
Operating Internal Frame Temperature	TF	-					-20 to +115	°C	
Operating Ambient Temperature	Top	-55 to +125			-55 to +115		°C		
Storage Temperature	Tstg	-55 to +125					°C		
Channel Temperature	Tch	150					°C		

Electrical Characteristics

(Ta = 25°C, Vcc = 20V, unless otherwise specified)

Parameter	Symbol	Ratings			Unit	Remarks
		min.	typ.	max.		
Power Supply Startup Operation						
Operation Startup Voltage	VCC(ON)	13.8	15.1	17.3	V	
Operation Stop Voltage	VCC(OFF)	8.4	9.4	10.7	V	
Circuit Current During Operation	ICC(ON)	-	-	4.7	mA	
Startup Circuit Operation Voltage	VSTARTUP	18	21	24	V	
Startup Current	ICC(STARTUP)	-8.5	-4.0	-1.5	mA	Vcc=13V
Startup Current Supply Threshold Voltage	VCC(BIAS)	9.5	11	12.5	V	
Normal Operation						
PWM Oscillation Frequency	fosc	60	72	84	kHz	LC5545LD/48L
		50	60	70		LC5546LD
		33	40	47		LC554xLF
Maximum ON Time	ton(MAX)	8.0	9.3	11.2	μs	LC5545LD/48L
		9.0	11.2	13.4		LC5546LD
		14	17.5	21		LC554xLF
FB Pin Control Lower Voltage	VFB(MIN)	0.50	0.85	1.20	V	
Maximum Feedback Current	IFB(MAX)	-40	-25	-10	μA	
Leading Edge Blanking Time	ton(LEB)	-	600	-	ns	
Quasi-Resonant Operation Threshold Voltage 1	VBD(TH1)	0.14	0.24	0.34	V	
Quasi-Resonant Operation Threshold Voltage 2	VBD(TH2)	0.11	0.16	0.21	V	
Protection Operation						
Overcurrent Detection Threshold Voltage	VOCP	-0.66	-0.60	-0.54	V	
OCP Pin Outflow Current	IOCP	-120	-40	-10	μA	
OCP Pin OVP Threshold Voltage	VBD(OVP)	2.2	2.6	3.0	V	
OLP Threshold Voltage	VCOMP(OLP)	4.1	4.5	4.9	V	
OVP Pin OVP Threshold Voltage	VOVP(OVP)	1.6	2.0	2.4	V	
VCC Pin OVP Threshold Voltage	VCC(OVP)	28.5	31.5	34.0	V	
TSD Operating Temperature	Tj(TSD)	135	-	-	°C	
MOSFET						
ON Resistance	Rds(ON)	-	-	3.95	Ω	LC5545LD
		-	-	1.9		LC5546LD
		-	-	3.5		LC5548LD
		-	-	1.9		LC5546LF
		-	-	1.1		LC5547LF
Switching Time	tr	-	-	1.7	ns	LC5549LF
		-	-	250		LC5545LD
		-	-	400		LC5546LD
		-	-	400		LC5548LD
		-	-	400		LC5546LF
Thermal Resistance*3	θch-c	-	-	42*2	°C/W	LC5545LD
		-	-	35.5*2		LC5546LD
		-	-	40*2		LC5548LD
		-	-	3.1*3		LC5546LF
		-	-	2.2*3		LC5547LF
Thermal Resistance*3	θch-F	-	-	2.2*3	°C/W	LC5549LF
		-	-	2.2*3		

For the polarity of current values, the sink is defined as "positive" and the source is defined as "negative" with respect to the IC.

*1: The relationship VCC(BIAS)1 > VCC(OFF) holds true for all products.

*2: Thermal resistance between the MOSFET channel and the case. The case temperature Tc is determined by the temperature at the center of the marking surface.

*3: Thermal resistance between the MOSFET channel and the internal frame

External Dimensions

(Unit : mm)

LC554xLD (DIP8)

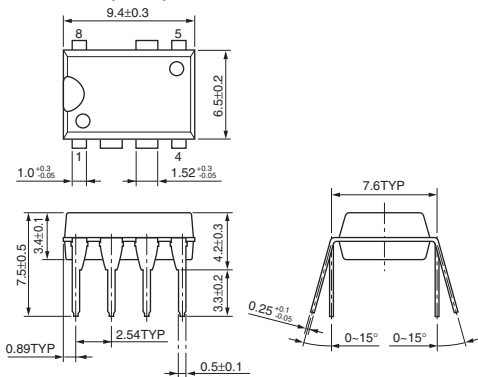

LC554xLF (TO220F-7)

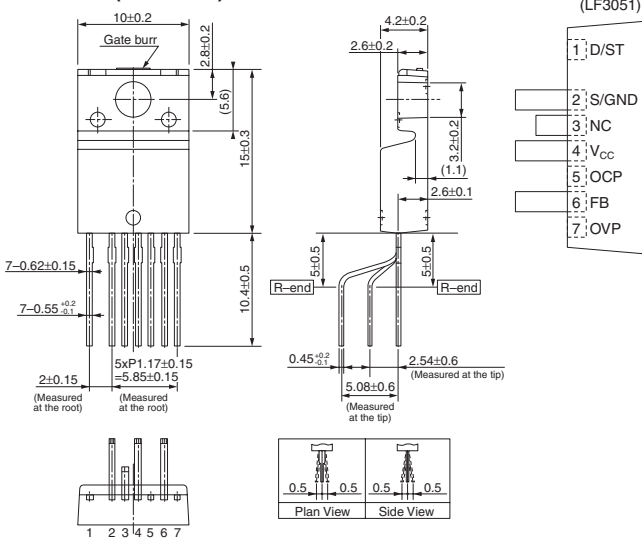

Pin Functions

LC554xLD (DIP8)

Pin No.	Symbol	Function
1	S/GND	MOSFET source and GND for control
2	Vcc	Control circuit power input and Overvoltage protection signal input
3	OCP	Overcurrent protection and Quasi-resonant signal input and Overvoltage protection signal input
4	FB	Feedback signal input and Overload protection signal input
5	NF	(No function*)
6	OVP	Overvoltage protection signal input
7	-	(Pin removed)
8	D/ST	MOSFET drain and Startup current input

*: NF (pin 5) connects to the stable potential S/GND pattern (pin 1 potential) via the shortest distance for stable operation.

LC554xLF (TO220F-7)

Pin No.	Symbol	Function
1	D/ST	MOSFET drain and Startup current input
2	S/GND	MOSFET source and GND for control
3	Vcc	Control circuit power input and Overvoltage protection signal input
4	OCP	Overcurrent protection and Quasi-resonant signal input and Overvoltage protection signal input
5	FB	Feedback signal input and Overload protection signal input
6	NC	-
7	OVP	Overvoltage protection signal input

Block Diagram

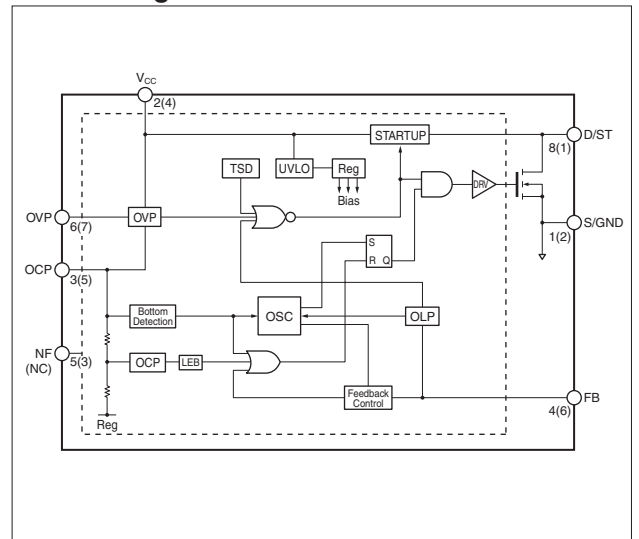

Typical Connection Diagram

The pin number for DIP8 is indicated. The pin number for TO220F-7 is indicated in parentheses.

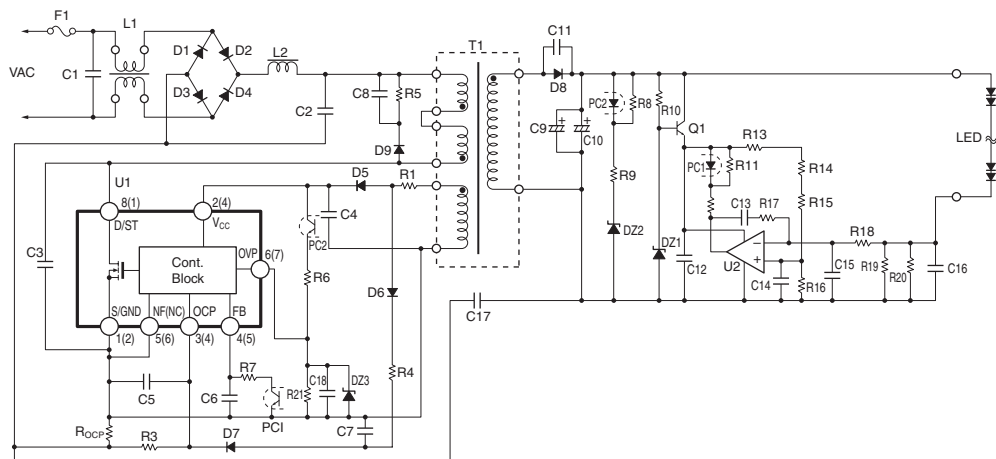

LC5720S Series Current Mode PWM Control LED Lighting IC

■ Features

- HSOP8 package
- Input voltage range (VIN): 8.5 to 50V
- High efficiency of at least 90%
- Current mode PWM control
- Buck, Boost, Buck-Boost operations
- PWM dimming
- Output current: 2A
- Oscillation frequency: 500kHz
- Protection functions
 - Overcurrent protection (OCP)
 - Overvoltage protection (OVP)
 - Thermal shutdown (TSD)

■ Applications

- DC input LED lighting
- Indoor/outdoor LED lighting
- LED spotlights
- RGB LED lighting

■ Absolute Maximum Ratings

(Ta = 25°C)

Parameter	Symbol	Ratings	Unit	Conditions
VIN Pin Voltage	VIN	-0.3 to 50	V	
SW Pin Voltage	Vsw	-0.3 to 50	V	
CSP Pin Voltage	Vcsp	-0.3 to 50	V	
CSN Pin Voltage	Vcsn	-0.3 to 50	V	
CSP/CSN Pin Differential Voltage	Vcsp-csn	-0.3 to 5.5	V	
COMP Pin Voltage	Vcomp	-0.3 to 5.5	V	
DIM Pin Voltage	Vdim	-0.3 to 5.5	V	
Power Dissipation	Pd	1.35	W	Measured on a 30×30mm glass-epoxy board (with a 625mm ² copper area)
Junction Temperature	Tj	125	°C	
Storage Temperature	Tstg	-40 to 150	°C	
Thermal Resistance (Junction to Ambient Air)	θj-a	74	°C/W	Measured on a 30×30mm glass-epoxy board (with a 625mm ² copper area)

■ Recommended Operating Conditions

Parameter	Symbol	Ratings	Unit
Input Voltage Range	VIN	9 to 46	V
Output Current Range	IOUT	Up to 2.0	A
PK- PK Inductor Ripple Current	ΔIL	Up to 0.8	A
PWM Dimmer Signal Frequency Range	fPWM	32 to 20000	Hz
Operating Temperature Range	TOP	-40 to 85	°C

*: Exceeding these ratings may damage the device.

■ Electrical Characteristics

(Ta = 25°C, VIN = 15V, unless otherwise specified)

Parameter	Symbol	Ratings			Unit	Conditions
		min.	typ.	max.		
Operation Startup Voltage	VIN (ON)	7.7	8.5	9.4	V	
Operation Stop Voltage	VIN (OFF)	7.2	8.0	8.9	V	
Operation Startup/Stop Hysteresis	VIN (HYS)	0.1	0.3	0.5	V	
Supply Current (Operating)	IIN (ON)			7.0	mA	
Supply Current (Shutdown)	IIN (OFF)			1000	μA	VIN=6.5V
Oscillation Frequency	fosc	420	500	570	kHz	
Minimum ON Time	ton (MIN)	35	75	100	nsec	VCOMP=0V
Maximum ON Duty	DMAX	89	94	98	%	VCOMP=4V
ON Time 1	ton (1)	300	600	800	nsec	VCOMP=0.7V
ON Time 2	ton (2)	0.85	1.4	1.8	usec	VCOMP=1.2V
Current Sense Voltage	VCS	95	100	105	mV	
CSP Pin Input Current	Icsp	85	130	175	μA	
CSN Pin Input Current	Icsn	40	65	95	μA	
CSP Pin Operation Voltage	Vcsp (OPR)	4.75		50	V	
COMP Pin Source Current	Icomp (SO)	-95	-60	-38	μA	VCS=20mV, VCOMP=2V
COMP Pin Sink Current	Icomp (SI)	38	60	95	μA	VCS=180mV, VCOMP=2V
OVP Threshold	VCS (OVP)	200	240	280	mV	
SW Pin Leakage Current	ISW (LEAK)			100	μA	
DIM Pin Voltage During LED ON	Vdim (ON)	1.2	1.4	1.7	V	
DIM Pin Voltage During LED OFF	Vdim (OFF)	0.75	1.0	1.2	V	
DIM Pin Hysteresis	Vdim (HYS)	0.3	0.5	0.7	V	
Error Amplifier Conductance	Gm		750		μS	
SW ON Resistance	Rsw (L)		215		mΩ	ISW=1A
SW Pin Limiting Current	ISW (LIM)		3.5		A	
Thermal Shutdown	TSD		160		°C	
Thermal Shutdown Hysteresis	TSD_hys		15		°C	

External Dimensions (HSOP8)

(Unit : mm)

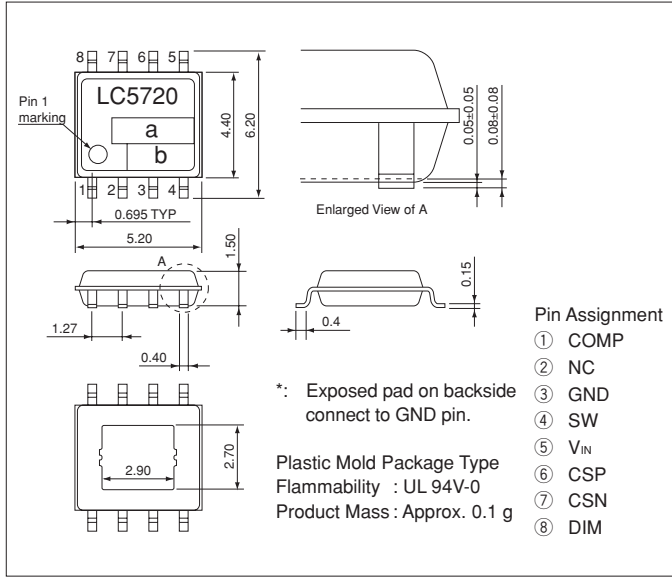

Block Diagram



Typical Connection Diagram

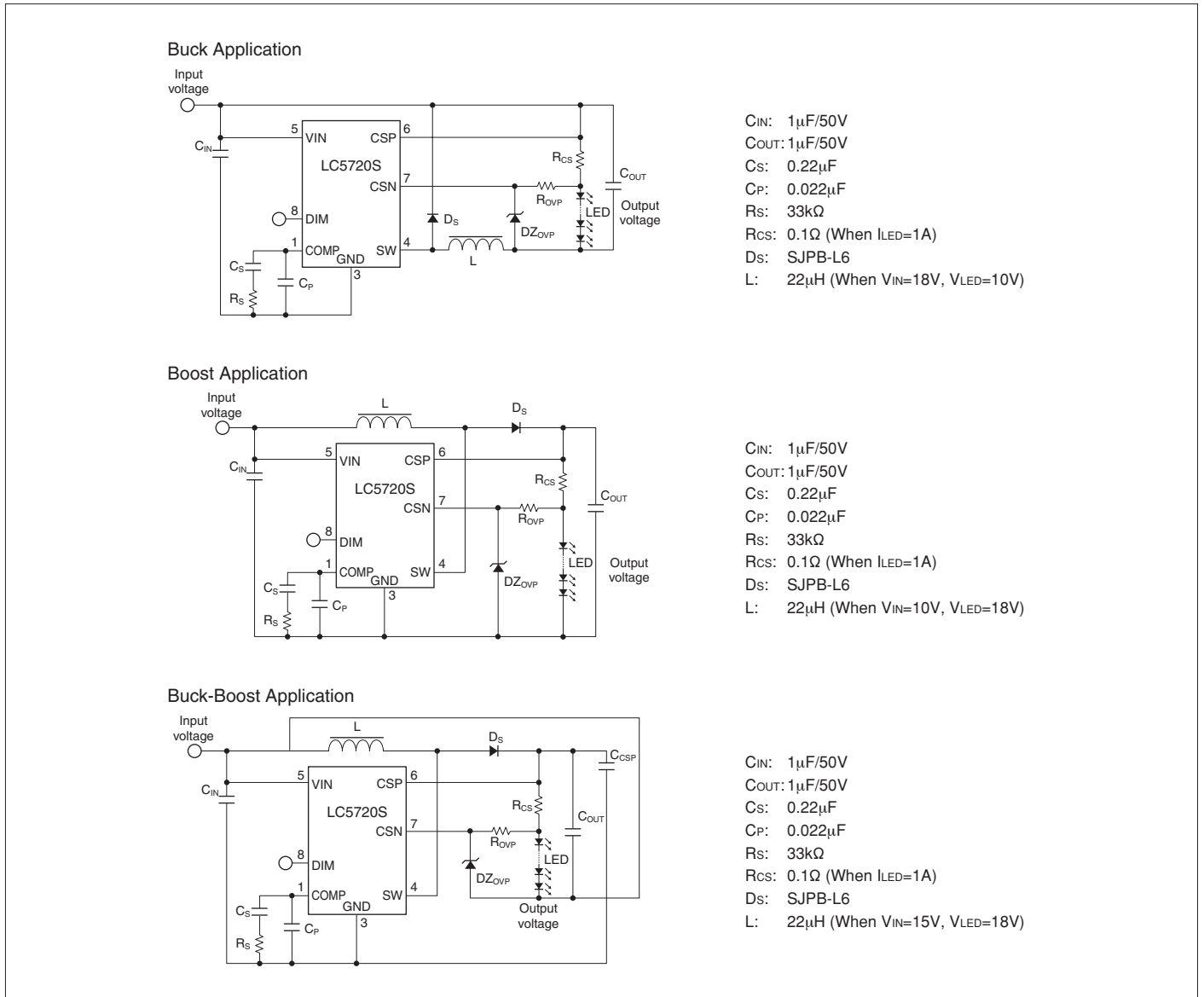

Transistors

Ordering Information & Standard Packing Quantities	154
Application Note	156
2-1 Transistors	157
Selection Guide	157
• VCEO-IC	157
• Audio Transistors	158
• Switching Transistors	159
Specifications List by Part Number	160
2-2 MOS FETs	167
Selection Guide	167
• By VDSS	167
Specifications List by Part Number	168
2-3 IGBT	171
Selection Guide	171
• By VCES	171
Specifications List by Part Number	172
2-4 Transistor and MOS FET Arrays	174
Specifications List by Part Number	174
Specifications List by Application	176
• Sink Driver Arrays	176
• Source Driver Arrays	178
• Motor Driver Arrays	180
• Partial switching PFC Arrays	184
Part Number List by Application	186
Package Type (Dimensions)	189

Ordering Information

All products listed must be ordered in standard packing increments.

Series Name/ Product Name	Package	Standard Packing Quantities	
		Bulk	Taping
2SA1186	TO3P	500(Box)/1080(Stick)	–
2SA1215	MT200	250(Box)	–
2SA1216	MT200	250(Box)	–
2SA1294	TO3P	500(Box)/1080(Stick)	–
2SA1295	MT200	250(Box)	–
2SA1303	TO3P	500(Box)/1080(Stick)	–
2SA1386	TO3P	500(Box)/1080(Stick)	–
2SA1386A	TO3P	500(Box)/1080(Stick)	–
2SA1488	TO220F	1000(Box)/3750(Stick)	–
2SA1488A	TO220F	1000(Box)/3750(Stick)	–
2SA1492	TO3P	500(Box)/1080(Stick)	–
2SA1493	MT200	250(Box)	–
2SA1494	MT200	250(Box)	–
2SA1567	TO220F	1000(Box)/3750(Stick)	–
2SA1568	TO220F	1000(Box)/3750(Stick)	–
2SA1667	TO220F	1000(Box)/3750(Stick)	–
2SA1668	TO220F	1000(Box)/3750(Stick)	–
2SA1673	TO3PF	500(Box)/1080(Stick)	–
2SA1693	TO3P	500(Box)/1080(Stick)	–
2SA1694	TO3P	500(Box)/1080(Stick)	–
2SA1695	TO3P	500(Box)/1080(Stick)	–
2SA1725	TO220F	1000(Box)/3750(Stick)	–
2SA1746	TO3PF	500(Box)/1080(Stick)	–
2SA1859	TO220F	1000(Box)/3750(Stick)	–
2SA1859A	TO220F	1000(Box)/3750(Stick)	–
2SA1860	TO3PF	500(Box)/1080(Stick)	–
2SA1907	TO3PF	500(Box)/1080(Stick)	–
2SA1908	TO3PF	500(Box)/1080(Stick)	–
2SA1909	TO3PF	500(Box)/1080(Stick)	–
2SA2151	TO3P	500(Box)/1080(Stick)	–
2SA2151A	TO3P	500(Box)/1080(Stick)	–
2SA2223	TO3P	500(Box)/1080(Stick)	–
2SB1257	TO220F	1000(Box)/3750(Stick)	–
2SB1258	TO220F	1000(Box)/3750(Stick)	–
2SB1259	TO220F	1000(Box)/3750(Stick)	–
2SB1351	TO220F	1000(Box)/3750(Stick)	–
2SB1382	TO3PF	500(Box)/1080(Stick)	–
2SB1383	TO3P	500(Box)/1080(Stick)	–
2SB1420	TO3P	500(Box)/1080(Stick)	–
2SB1559	TO3P	500(Box)/1080(Stick)	–
2SB1560	TO3P	500(Box)/1080(Stick)	–
2SB1570	MT200	250(Box)	–
2SB1587	TO3PF	500(Box)/1080(Stick)	–
2SB1588	TO3PF	500(Box)/1080(Stick)	–
2SB1647	TO3P	500(Box)/1080(Stick)	–
2SB1648	MT200	250(Box)	–
2SB1649	TO3PF	500(Box)/1080(Stick)	–
2SC2837	TO3P	500(Box)/1080(Stick)	–
2SC2921	MT200	250(Box)	–
2SC2922	MT200	250(Box)	–
2SC3263	TO3P	500(Box)/1080(Stick)	–
2SC3264	MT200	250(Box)	–

Series Name/ Product Name	Package	Standard Packing Quantities	
		Bulk	Taping
2SC3284	TO3P	500(Box)/1080(Stick)	–
2SC3519	TO3P	500(Box)/1080(Stick)	–
2SC3519A	TO3P	500(Box)/1080(Stick)	–
2SC3835	TO3P	500(Box)/1080(Stick)	–
2SC3851	TO220F	1000(Box)/3750(Stick)	–
2SC3851A	TO220F	1000(Box)/3750(Stick)	–
2SC3852	TO220F	1000(Box)/3750(Stick)	–
2SC3852A	TO220F	1000(Box)/3750(Stick)	–
2SC3856	TO3P	500(Box)/1080(Stick)	–
2SC3857	MT200	250(Box)	–
2SC3858	MT200	250(Box)	–
2SC3927	TO3P	500(Box)/1080(Stick)	–
2SC4024	TO220F	1000(Box)/3750(Stick)	–
2SC4131	TO3PF	500(Box)/1080(Stick)	–
2SC4138	TO3P	500(Box)/1080(Stick)	–
2SC4140	TO3P	500(Box)/1080(Stick)	–
2SC4153	TO220F	1000(Box)/3750(Stick)	–
2SC4300	TO3PF	500(Box)/1080(Stick)	–
2SC4301	TO3PF	500(Box)/1080(Stick)	–
2SC4304	TO220F	1000(Box)/3750(Stick)	–
2SC4381	TO220F	1000(Box)/3750(Stick)	–
2SC4382	TO220F	1000(Box)/3750(Stick)	–
2SC4388	TO3PF	500(Box)/1080(Stick)	–
2SC4445	TO3PF	500(Box)/1080(Stick)	–
2SC4466	TO3P	500(Box)/1080(Stick)	–
2SC4467	TO3P	500(Box)/1080(Stick)	–
2SC4468	TO3P	500(Box)/1080(Stick)	–
2SC4495	TO220F	1000(Box)/3750(Stick)	–
2SC4511	TO220F	1000(Box)/3750(Stick)	–
2SC4518	TO220F	1000(Box)/3750(Stick)	–
2SC4518A	TO220F	1000(Box)/3750(Stick)	–
2SC4546	TO220F	1000(Box)/3750(Stick)	–
2SC4706	TO3P	500(Box)/1080(Stick)	–
2SC4883	TO220F	1000(Box)/3750(Stick)	–
2SC4883A	TO220F	1000(Box)/3750(Stick)	–
2SC4886	TO3PF	500(Box)/1080(Stick)	–
2SC5071	TO3P	500(Box)/1080(Stick)	–
2SC5099	TO3PF	500(Box)/1080(Stick)	–
2SC5100	TO3PF	500(Box)/1080(Stick)	–
2SC5101	TO3PF	500(Box)/1080(Stick)	–
2SC5130	TO220F	1000(Box)/3750(Stick)	–
2SC5287	TO3P	500(Box)/1080(Stick)	–
2SC6011	TO3P	500(Box)/1080(Stick)	–
2SC6011A	TO3P	500(Box)/1080(Stick)	–
2SC6145	TO3P	500(Box)/1080(Stick)	–
2SD1785	TO220F	1000(Box)/3750(Stick)	–
2SD1796	TO220F	1000(Box)/3750(Stick)	–
2SD2014	TO220F	1000(Box)/3750(Stick)	–
2SD2015	TO220F	1000(Box)/3750(Stick)	–
2SD2016	TO220F	1000(Box)/3750(Stick)	–
2SD2017	TO220F	1000(Box)/3750(Stick)	–
2SD2045	TO3PF	500(Box)/1080(Stick)	–

Series Name/ Product Name	Package	Standard Packing Quantities	
		Bulk	Taping
2SD2081	TO220F	1000(Box)/3750(Stick)	–
2SD2082	TO3PF	500(Box)/1080(Stick)	–
2SD2083	TO3P	500(Box)/1080(Stick)	–
2SD2141	TO220F	1000(Box)/3750(Stick)	–
2SD2389	TO3P	500(Box)/1080(Stick)	–
2SD2390	TO3P	500(Box)/1080(Stick)	–
2SD2401	MT200	250(Box)	–
2SD2438	TO220F	1000(Box)/3750(Stick)	–
2SD2439	TO3PF	500(Box)/1080(Stick)	–
2SD2560	TO3P	500(Box)/1080(Stick)	–
2SD2561	MT200	250(Box)	–
2SD2562	TO3PF	500(Box)/1080(Stick)	–
2SD2641	TO3P	500(Box)/1080(Stick)	–
2SD2642	TO220F	1000(Box)/3750(Stick)	–
2SD2643	TO3PF	500(Box)/1080(Stick)	–
2SK2420	TO220F	3750(Stick)	–
2SK2701A	TO220F	3750(Stick)	–
2SK2803	TO220F	3750(Stick)	–
2SK2848	TO220F	3750(Stick)	–
2SK2943	TO220F	3750(Stick)	–
2SK3003	TO220F	3750(Stick)	–
2SK3004	TO220F	3750(Stick)	–
2SK3199	TO220F	3750(Stick)	–
2SK3710	TO220S(Surface-mount)	–	1000
2SK3711	TO3P	1080(Stick)	–
2SK3800	TO220S(Surface-mount)	–	1000
2SK3801	TO3P	1080(Stick)	–
EKG1020	TO220	4000(Stick)	–
EKH04100	TO220	4000(Stick)	–
EKH06100	TO220	4000(Stick)	–
EKH1070	TO220	4000(Stick)	–
EKV550	TO220	1000(Stick)	–
FGM603	TO3PF	1080(Stick)	–
FGM622S	TO3PF	1080(Stick)	–
FGM623S	TO3PF	1080(Stick)	–
FKG1020	TO220F-A	4000(Stick)	–
FKH0470	TO220F-A	4000(Stick)	–
FKH0660	TO220F-A	4000(Stick)	–
FKH1040	TO220F-A	4000(Stick)	–
FKP202	TO220F	3750(Stick)	–
FKP250A	TO3PF	1080(Stick)	–
FKP252	TO220F	3750(Stick)	–
FKP253	TO220F	3750(Stick)	–
FKP280A	TO3PF	1080(Stick)	–
FKP300A	TO3PF	1080(Stick)	–
FKP330C	TO3PF	1080(Stick)	–
FKV460S	TO220S(Surface-mount)	–	1000
FKV550N	TO220F	3750(Stick)	–
FKV575	TO220F	3750(Stick)	–
FKV660S	TO220S(Surface-mount)	–	1000
MGD623N	TO3P	1080(Stick)	–
MGD623S	TO3P	1080(Stick)	–

Series Name/ Product Name	Package	Standard Packing Quantities	
		Bulk	Taping
MKS5015	TO3P	1440(Stick)	–
MKS5020	TO3P	1440(Stick)	–
SKH04100	TO263(Surface-mount)	–	6400
SKH06100	TO263(Surface-mount)	–	6400
SKH1070	TO263(Surface-mount)	–	6400
SKP202	TO263(Surface-mount)	–	6400
SKP253	TO263(Surface-mount)	–	6400
SLA4xxx	SLA12Pin	250(Box)/1080(Stick)	–
SLA4xxx	SLA21Pin	250(Box)/1080(Stick)	–
SLA5xxx	SLA12Pin	250(Box)/1080(Stick)	–
SLA5xxx	SLA15Pin	250(Box)/1080(Stick)	–
SLA6xxx	SLA12Pin	250(Box)/1080(Stick)	–
SMA4xxx	SMA12Pin	1440(Stick)	–
SMA5xxx	SMA12Pin	1440(Stick)	–
SMA5xxx	SMA15Pin	1440(Stick)	–
SMA6xxx	SMA12Pin	1440(Stick)	–
STAxxx	STA8Pin	1000(Box)/4050(Stick)	–
STAxxx	STA10Pin	3200(Box)/3300(Stick)	–
STD01N	TO3P-5	500(Box)/1080(Stick)	–
STD01P	TO3P-5	500(Box)/1080(Stick)	–
STD03N	TO3P-5	500(Box)/1080(Stick)	–
STD03P	TO3P-5	500(Box)/1080(Stick)	–

Application Note

Since reliability can be affected adversely by improper storage environment or handling methods during Characteristic tests, please observe the following cautions.

■ Cautions for Storage

- Ensure that storage conditions comply with the normal temperature (5 to 35°C) and the normal relative humidity (around 40 to 75%), and avoid storage locations that experience high temperature and humidity, or extreme changes in temperature or humidity.
- Avoid locations where dust or harmful gases are present, and avoid direct sunlight.
- Reinspect the devices for rust in leads and solderability after stored for a long time.

■ Cautions for Characteristic Tests and Handling

On characteristics test at incoming inspection, etc, take good care to avoid the surge voltages from the test equipment, the short circuit at terminals, or the wrong connection.

■ Silicone Grease

When using a heatsink, please coat thinly and evenly the back surface of the device and both surfaces of the insulating plate with silicone grease to lower the thermal resistance between the device and the heatsink. Please select proper silicone grease carefully since the oil in some grease products may penetrate the device and result in an extremely short device life.

Recommended Silicone Grease

- G-746 (Shin-Etsu Chemical)
- YG6260 (Momentive Performance Materials Inc.)
- SC102 (Dow Corning Toray Silicone)

■ Mounting Torque

When mounting torque is insufficient, thermal resistance increases, and so heat radiation effect is decreased. When the torque is excessive, the screw may be broken, the heatsink may be deformed, and the device frame may be distorted, resulting in the device damage. Recommended mounting torque per package is as follows:

● Mounting Torque Table

Package	Screw Torque
TO-220	0.490 to 0.686 N·m (5 to 7kgf·cm)
TO-220F (FM20)	
TO-3P (MT-100)	0.686 to 0.882 N·m (7 to 9kgf·cm)
TO-3PF(FM100)	
MT-200 (fixed at two points)	
SIP with Fin (SLA)	0.588 to 0.784 N·m (6 to 8kgf·cm)

* When the surface of a heatsink where Full Mold package is to be mounted is not flat due to the burred metal bracket for screwing around the mounting hole of the heatsink, the resin of the package might be cracked even if the torque is lower than the recommended value.

* When a screw is fastened with an air driver for the Full Mold package, a large impact is generated at the time of stop, and the resin may crack even if the torque is lower than the recommended value. An electric driver, therefore, should be used instead of an air driver.

■ Heatsink

A larger contact area between the device and the heatsink is required for more effective heat radiation. To ensure a larger contact area, minimize mounting holes. And select a heatsink with a surface smooth enough and free from burrs and slivers.

■ Soldering Temperature

In general, the device mounted on a printed circuit board is subjected to high temperatures from flow solder in a solder bath, or, from a soldering iron at hand soldering.

The testing method and test conditions for a device's heat resistance to soldering are:

At a distance of 1.5mm from the device's main body, apply 260°C for 10 seconds, and 350°C for 3 seconds.

Please observe these limits and finish soldering in as short a time as possible.

■ Antistatic Measure for Power MOS FET Arrays

- When handling the device, body grounding is necessary. Wear a wrist strap with a 1 MΩ resistor close to the body in the wrist strap to prevent electric shock.
- Use a conductive tablemat and a floor mat at the device-handling workbench and ground them properly.
- When using a curve tracer or other measuring equipment, ground them as well.
- In soldering, ground the soldering iron tip and the solder bath to prevent a leakage voltage from damaging the device.
- As an antistatic measure for device containers, use Sanken shipping containers or a conductive containers, or use aluminum foils. Since reliability can be affected adversely by improper storage environment or handling methods during Characteristic tests, please observe the following cautions.

Selection Guide

$V_{CEO}-I_c$

Collector-Emitter Voltage $V_{CEO}(V)$	800		C4304 C4445		C4300		C4301									
	600										C4706					
	550					C4518 C4518A C5287			C3927							
	400					C5130		C4546		C4138	C5071				C4140	
	380						D2141									
	250						D2017									
	230												A1294 C3263 A2151A C6011A A2223 C6145		A1295 C3264	
	200	A1668 C4382	D2016										A1493 C3857 A2151 C6011		A1494 C3858	
	180	A1859A C4883A											A1386A A1492 A1673 C3519A C3856 C4388		A1216 C2922	
	160												A1215 A1386 C2921 C3519			
	150	A1667 A1859 C4381 C4883						B1559 B1587 D2389 D2438	A1186 B1560 B1588 C2837 D2390 D2439	B1570 D2401	A1303 A1860 C3284 C4886		B1647 B1649 D2560 D2562		B1648 D2561	
	140								A1695 A1909 C4468 C5101							
	120			D2015		D1785 D2045	C3835 C4153	A1694 A1908 C4467 C5100	B1259 D2081					B1382 B1420 D2082		B1383 D2083
	110					D2641 D2642 D2643										
	100					B1258										
	80		C3852A	A1488A C3851A D2014		A1693 A1725 A1907 C4466 C4511 C5099										
60		C3852	A1488 B1257 C3851 D1796							A1568 B1351						
50		C4495						C4024		A1567 A1746		C4131				
		2	3	4	5	6	7	8	10	12	14	15	16	17	18	25
		Collector Current $I_c(A)$														

Audio Transistors

Output Transistors

P _c (W)	I _c (A)	V _{CE0} (V)	Chip						Package
			Single Transistors				Darlington		
			General		LAPT				
30	6	80	2SA1725	2SC4511					TO-220F (FM20)
60	6	80	2SA1693	2SC4466					TO-3P (MT-100)
	6	80	2SA1907	2SC5099					TO-3PF (FM100)
75	8	120	2SA1908	2SC5100					TO-3PF (FM100)
	8	150					2SB1587	2SD2438	TO-3PF (FM100)
80	8	120	2SA1694	2SC4467					TO-3P (MT-100)
	10	140	2SA1909	2SC5101					TO-3PF (FM100)
	8	150					2SB1559	2SD2389	TO-3P (MT-100)
	10	150					2SB1588	2SD2439	TO-3PF (FM100)
85	14	150			2SA1860	2SC4886			TO-3PF (FM100)
	15	150					2SB1649	2SD2562	TO-3PF (FM100)
	15	180	2SA1673	2SC4388					TO-3PF (FM100)
100	10	140	2SA1695	2SC4468					TO-3P (MT-100)
	10	150			2SA1186	2SC2837			TO-3P (MT-100)
	10	150					2SB1560	2SD2390	TO-3P (MT-100)
125	14	150			2SA1303	2SC3284			TO-3P (MT-100)
130	15	150					2SB1647	2SD2560	TO-3P (MT-100)
	15	160			2SA1386	2SC3519			TO-3P (MT-100)
	15	180	2SA1492	2SC3856					TO-3P (MT-100)
	15	180			2SA1386A	2SC3519A			TO-3P (MT-100)
	15	230			2SA1294	2SC3263			TO-3P (MT-100)
150	12	150					2SB1570	2SD2401	MT-200 (fixed at two points)
	15	160			2SA1215	2SC2921			MT-200 (fixed at two points)
	15	200	2SA1493	2SC3857					MT-200 (fixed at two points)
160	15	200	2SA2151	2SC6011					TO-3P (MT-100)
	15	230	2SA2151A	2SC6011A					TO-3P (MT-100)
	15	230	2SA2223	2SC6145					TO-3P (MT-100)
200	17	150					2SB1648	2SD2561	MT-200 (fixed at two points)
	17	180			2SA1216	2SC2922			MT-200 (fixed at two points)
	17	200	2SA1494	2SC3858					MT-200 (fixed at two points)
	17	230			2SA1295	2SC3264			MT-200 (fixed at two points)

LAPT (Linear Amplified Power Transistor): Multi-Emitter Transistor for High-Frequency

Output Transistors with Temperature Compensating Function (Refer to our Web site for applications)

Part Number	P _c (W)	I _c (A)	V _{CE0} (V)	Package
STD01P	100	10	150	TO3P-5pin
STD03P	160	15	160	TO3P-5pin

Driver and Temperature Compensating Transistors

Part Number	P _c (W)	V _{CE0} (V)	I _c (A)	h _{FE} (min)	f _T (MHz)	Package	Remarks
2SC4495	25	50	3	500	40	TO-220F (FM20)	For temperature compensation
2SA1859	20	150	2	60	60/120	TO-220F (FM20)	Driver
2SA1859A	20	180	2	60	60/120	TO-220F (FM20)	Driver
2SA1667	25	150	2	60	20/15	TO-220F (FM20)	Driver
2SA1668	25	200	2	60	20/15	TO-220F (FM20)	Driver

Refer to our Web site for the h_{FE} ranks.

Switching Transistors

■DC-DC Converter

Part Number	V _{CB0} (V)	V _{CE0} (V)	I _c (A)	P _c (W)	Package
2SC4024	100	50	10	35	TO-220F
2SC4131			15	60	TO-3PF
2SC4153	200	120	7	30	TO-220F
2SC3835				70	TO-3P

■For AC100V Input

Part Number	V _{CB0} (V)	V _{CE0} (V)	I _c (A)	P _c (W)	Package
2SC4138	500	400	10	80	TO-3P
2SC5071			12	100	TO-3P
2SC4140			18	130	TO-3P
2SC5130	600	400	5	30	TO-220F
2SC4546			7	30	TO-220F

■For AC200V Input

Part Number	V _{CB0} (V)	V _{CE0} (V)	I _c (A)	P _c (W)	Package	
2SC4518	900	550	5	35	TO-220F	
2SC5287				80	TO-3P	
2SC3927			10	120	TO-3P	
2SC4706		600	14	130	TO-3P	
2SC4304		800	800	3	35	TO-220F
2SC4445				60	TO-3PF	
2SC4300				5	75	TO-3PF
2SC4301				7	80	TO-3PF
2SC4518A		1000	550	5	35	TO-220F

Specifications List by Part Number

Part Number	Applications	Absolute Maximum Ratings				I _{CBO}		h _{FE}		Conditions	
		V _{CBO}	V _{CEO}	I _C	P _c	I _{CBO} (μA)	V _{CB} (V)	min	max	Conditions	
		(V)	(V)	(A)	(W)					V _{CE} (V)	I _C (A)
2SA1186	Audio, general-purpose	-150	-150	-10	100	-100	-150	50	180	-4	-3
2SA1215	Audio, general-purpose	-160	-160	-15	150	-100	-160	50	180	-4	-5
2SA1216	Audio, general-purpose	-180	-180	-17	200	-100	-180	30	180	-4	-8
2SA1294	Audio, general-purpose	-230	-230	-15	130	-100	-230	50	140	-4	-5
2SA1295	Audio, general-purpose	-230	-230	-17	200	-100	-230	50	140	-4	-5
2SA1303	Audio, general-purpose	-150	-150	-14	125	-100	-150	50	180	-4	-5
2SA1386	Audio, general-purpose	-160	-160	-15	130	-100	-160	50	180	-4	-5
2SA1386A	Audio, general-purpose	-180	-180	-15	130	-100	-180	50	180	-4	-5
2SA1488	Audio, general-purpose	-60	-60	-4	25	-100	-60	40		-4	-1
2SA1488A	Audio, general-purpose	-80	-80	-4	25	-100	-80	40		-4	-1
2SA1492	Audio, general-purpose	-180	-180	-15	130	-100	-180	50	180	-4	-3
2SA1493	Audio, general-purpose	-200	-200	-15	150	-100	-200	50	180	-4	-5
2SA1494	Audio, general-purpose	-200	-200	-17	200	-100	-200	50	180	-4	-8
2SA1567	DC motor driver, chopper regulator, general-purpose	-50	-50	-12	35	-100	-50	50		-1	-6
2SA1568	DC motor driver, chopper regulator, general-purpose	-60	-60	±12	35	-100	-60	50		-1	-6
2SA1667	TV vertical output, audio output driver, general-purpose	-150	-150	-2	25	-10	-150	60		-10	-0.7
2SA1668	TV vertical output, audio output driver, general-purpose	-200	-200	-2	25	-10	-200	60		-10	-0.7
2SA1673	Audio, general-purpose	-180	-180	-15	85	-10	-180	50	180	-4	-3
2SA1693	Audio, general-purpose	-80	-80	-6	60	-10	-80	50	180	-4	-2
2SA1694	Audio, general-purpose	-120	-120	-8	80	-10	-120	50	180	-4	-3
2SA1695	Audio, general-purpose	-140	-140	-10	100	-10	-140	50	180	-4	-3
2SA1725	Audio, general-purpose	-80	-80	-6	30	-10	-80	50	180	-4	-2
2SA1746	Chopper regulator, switch, general-purpose	-70	-50	-12 (Pulse -20)	60	-10	-70	50		-1	-5
2SA1859	Audio output driver, TV velocity modulation	-150	-150	-2	20	-10	-150	60	240	-10	-0.7
2SA1859A	Audio output driver, TV velocity modulation	-180	-180	-2	20	-10	-180	60	240	-10	-0.7
2SA1860	Audio, general-purpose	-150	-150	-14	80	-100	-150	50	180	-4	-5
2SA1907	Audio, general-purpose	-80	-80	-6	60	-10	-80	50	180	-4	-2
2SA1908	Audio, general-purpose	-120	-120	-8	75	-10	-120	50	180	-4	-3
2SA1909	Audio, general-purpose	-140	-140	-10	80	-10	-140	50	180	-4	-3
2SA2151	Audio, general-purpose	-200	-200	-15	160	-10	-200	50	180	-4	-3
2SA2151A	Audio, general-purpose	-230	-230	-15	160	-10	-230	50	180	-4	-3
2SA2223	Audio, general-purpose	-230	-230	-15	160	-10	-230	40	140	-4	-5
2SB1257	Solenoid/relay/motor driver, general-purpose	-60	-60	-4 (Pulse -6)	25	-10	-60	2000		-4	-3
2SB1258	Solenoid/relay/motor driver, general-purpose	-100	-100	-6 (Pulse -10)	30	-10	-100	1000		-2	-3
2SB1259	Solenoid/relay/motor driver, general-purpose	-120	-120	-10 (Pulse -15)	30	-10	-120	2000		-4	-5
2SB1351	Printer head/solenoid/relay/motor driver, general-purpose	-60	-60	-12 (Pulse -20)	30	-10	-60	2000		-4	-10
2SB1382	Chopper regulator, DC motor driver, general-purpose	-120	-120	-16 (Pulse -26)	75	-10	-120	2000		-4	-8
2SB1383	Chopper regulator, DC motor driver, general-purpose	-120	-120	-25 (Pulse -40)	120	-10	-120	2000		-4	-12
2SB1420	Chopper regulator, DC motor driver, general-purpose	-120	-120	-16 (Pulse -26)	80	-10	-120	2000		-4	-8
2SB1559	Audio, series regulator, general-purpose	-160	-150	-8	80	-100	-160	5000	30000	-4	-6
2SB1560	Audio, series regulator, general-purpose	-160	-150	-10	100	-100	-160	5000	30000	-4	-7
2SB1570	Audio, series regulator, general-purpose	-160	-150	-12	150	-100	-160	5000	30000	-4	-7
2SB1587	Audio, series regulator, general-purpose	-160	-150	-8	75	-100	-160	5000	30000	-4	-6
2SB1588	Audio, series regulator, general-purpose	-160	-150	-10	80	-100	-160	5000	30000	-4	-7
2SB1647	Audio, series regulator, general-purpose	-150	-150	-15	130	-100	-150	5000	30000	-4	-10
2SB1648	Audio, series regulator, general-purpose	-150	-150	-17	200	-100	-150	5000	30000	-4	-10
2SB1649	Audio, series regulator, general-purpose	-150	-150	-15	85	-100	-150	5000	30000	-4	-10

Electrical Characteristics													Complementary	Package	Mass (g)
V _{CE (sat)} (V) max	V _{BE (sat)} (V) max	Conditions		f _T MHz	Conditions		Switching Time			C _{ob} (pF)					
		I _c (A)	I _B (A)		V _{CE} (V)	I _E (A)	t _{on} (μS)	t _{stg} (μS)	t _f (μS)						
-2.0		-5	-0.5	60	-12	1	0.25typ	0.8typ	0.2typ	110typ	2SC2837	TO-3P (MT-100)			
-2.0		-5	-0.5	50	-12	2	0.25typ	0.85typ	0.2typ	400typ	2SC2921	MT-200	18.4		
-2.0		-8	-0.8	40	-12	2	0.3typ	0.7typ	0.2typ	500typ	2SC2922	MT-200	18.4		
-2.0		-5	-0.5	35	-12	2	0.35typ	1.5typ	0.3typ	500typ	2SC3263	TO-3P (MT-100)	6.0		
-2.0		-5	-0.5	35	-12	2	0.35typ	1.5typ	0.3typ	500typ	2SC3264	MT-200	18.4		
-2.0		-5	-0.5	50	-12	2	0.25typ	0.85typ	0.2typ	400typ	2SC3284	TO-3P (MT-100)	6.0		
-2.0		-5	-0.5	40	-12	2	0.3typ	0.7typ	0.2typ	500typ	2SC3519	TO-3P (MT-100)	6.0		
-2.0		-5	-0.5	40	-12	2	0.3typ	0.7typ	0.2typ	500typ	2SC3519A	TO-3P (MT-100)	6.0		
-0.5		-2	-0.2	15	-12	0.2	0.25typ	0.75typ	0.25typ	90typ	2SC3851	TO-220F (FM20)	2.0		
-0.5		-2	-0.2	15	-12	0.2	0.25typ	0.75typ	0.25typ	90typ	2SC3851A	TO-220F (FM20)	2.0		
-2.0		-5	-0.5	20	-12	0.5	0.6typ	0.9typ	0.2typ	500typ	2SC3856	TO-3P (MT-100)	6.0		
-3.0		-10	-1	20	-12	0.5	0.3typ	0.9typ	0.2typ	400typ	2SC3857	MT-200	18.4		
-2.5		-10	-1	20	-12	1	0.6typ	0.9typ	0.2typ	500typ	2SC3858	MT-200	18.4		
-0.35		-6	-0.3	40	-12	0.5	0.4typ	0.4typ	0.2typ	330typ		TO-220F (FM20)	2.0		
-0.35		-6	-0.3	40	-12	0.5	0.4typ	0.4typ	0.2typ	330typ		TO-220F (FM20)	2.0		
-1.0		-0.7	-0.07	20	-12	0.2	0.4typ	1.5typ	0.5typ	60typ	2SC4381	TO-220F (FM20)	2.0		
-1.0		-0.7	-0.07	20	-12	0.2	0.4typ	1.5typ	0.5typ	60typ	2SC4382	TO-220F (FM20)	2.0		
-2.0		-5	-0.5	20	-12	0.5	0.6typ	0.9typ	0.2typ	500typ	2SC4388	TO-3PF (FM100)	6.5		
-1.5		-2	-0.2	20	-12	0.5	0.18typ	1.1typ	0.21typ	150typ	2SC4466	TO-3P (MT-100)	6.0		
-1.5		-3	-0.3	20	-12	0.5	0.14typ	1.4typ	0.21typ	300typ	2SC4467	TO-3P (MT-100)	6.0		
-0.5		-5	-0.5	20	-12	0.5	0.17typ	1.86typ	0.27typ	400typ	2SC4468	TO-3P (MT-100)	6.0		
-0.5		-2	-0.2	20	-12	0.5	0.18typ	1.1typ	0.21typ	150typ	2SC4511	TO-220F (FM20)	2.0		
-0.5	-1.2	-5	-0.08	25	-12	1	0.5typ	0.6typ	0.3typ	400typ		TO-3PF (FM100)	6.5		
-1.0		-0.7	-0.07	60	-12	0.7	0.5typ	1typ	0.5typ	30typ	2SC4883	TO-220F (FM20)	2.0		
-1.0		-0.7	-0.07	60	-12	0.7	0.5typ	1typ	0.5typ	30typ	2SC4883A	TO-220F (FM20)	2.0		
-2.0		-5	-0.5	50	-12	2	0.25typ	0.85typ	0.2typ	400typ	2SC4886	TO-3PF (FM100)	6.5		
-0.5		-12	-0.2	20	-12	0.5	0.18typ	1.1typ	0.21typ	150typ	2SC5099	TO-3PF (FM100)	6.5		
-0.5		-3	-0.3	20	-12	0.5	0.14typ	1.4typ	0.21typ	300typ	2SC5100	TO-3PF (FM100)	6.5		
-0.5		-5	-0.5	20	-12	0.5	0.17typ	1.86typ	0.27typ	400typ	2SC5101	TO-3PF (FM100)	6.5		
-0.5		-5	-0.5	20	-12	-0.5	-	-	-	450typ	2SC6011	TO-3P (MT-100)	6.0		
-0.5		-5	-0.5	20	-12	-0.5	-	-	-	450typ	2SC6011A	TO-3P (MT-100)	6.0		
-0.5		-5	-0.5	35	-12	2	-	-	-	500typ	2SC6145	TP-3P (MT-100)	6.0		
-1.5	-2.0	-3	-0.006	200	-12	0.2	0.4typ	0.8typ	0.6typ	75typ	2SD2014	TO-220F (FM20)	2.0		
-1.5	-2.0	-3	-0.006	100	-12	0.2	0.6typ	1.6typ	0.5typ	100typ	2SD1785	TO-220F (FM20)	2.0		
-1.5	-2.0	-5	-0.01	100	-12	0.2	0.6typ	1.6typ	0.5typ	145typ	2SD2081	TO-220F (FM20)	2.0		
-1.5	-2.0	-10	-0.02	130	-12	1	0.7typ	1.5typ	0.6typ	170typ		TO-220F (FM20)	2.0		
-1.5	-2.5	-8	-0.016	50	-12	1	0.8typ	1.8typ	1typ	350typ	2SD2082	TO-3PF (FM100)	6.5		
-1.8	-2.5	-12	-0.024	50	-12	1	1typ	3typ	1typ	230typ	2SD2083	TO-3P (MT-100)	6.0		
-1.5	-2.5	-8	-0.016	50	-12	1	1typ	3typ	1typ	350typ		TO-3P (MT-100)	6.0		
-2.5	-3.0	-6	-0.006	65	-12	1	0.7typ	3.6typ	0.9typ	160typ	2SD2389	TO-3P (MT-100)	6.0		
-2.5	-3.0	-7	-0.007	50	-12	2	0.8typ	3typ	1.2typ	230typ	2SD2390	TO-3P (MT-100)	6.0		
-2.5	-3.0	-7	-0.007	50	-12	2	0.8typ	3typ	1.2typ	230typ	2SD2401	MT-200	18.4		
-2.5	-3.0	-6	-0.006	65	-12	1	0.7typ	3.6typ	0.9typ	160typ	2SD2438	TO-3PF (FM100)	6.5		
-2.5	-3.0	-7	-0.007	50	-12	2	0.8typ	3typ	1.2typ	230typ	2SD2439	TO-3PF (FM100)	6.5		
-2.5	-3.0	-10	-0.01	45	-12	2	0.7typ	1.6typ	1.1typ	320typ	2SD2560	TO-3P (MT-100)	6.0		
-2.5	-3.0	-10	-0.01	45	-12	2	0.7typ	1.6typ	1.1typ	320typ	2SD2561	MT-200	18.4		
-2.5	-3.0	-10	-0.01	45	-12	2	0.7typ	1.6typ	1.1typ	320typ	2SD2562	TO-3PF (FM100)	6.5		

Part Number	Applications	Absolute Maximum Ratings						I _{CBO}		h _{FE}			
		V _{CB0}	V _{CE0}	I _c	P _c	I _{CBO} (μ A)	Conditions V _{CB} (V)	min	max	Conditions			
		(V)	(V)	(A)	(W)					V _{CE}	I _c		
										(V)	(A)		
2SC2837	Audio, general-purpose	150	150	10	100	100	150	50	180	4	3		
2SC2921	Audio, general-purpose	160	160	15	150	100	160	50	180	4	5		
2SC2922	Audio, general-purpose	180	180	17	200	100	180	30	180	4	8		
2SC3263	Audio, general-purpose	230	230	15	130	100	230	50	140	4	5		
2SC3264	Audio, general-purpose	230	230	17	200	100	230	50	140	4	5		
2SC3284	Audio, general-purpose	150	150	14	125	100	150	50	180	4	5		
2SC3519	Audio, general-purpose	160	160	15	130	100	160	50	180	4	5		
2SC3519A	Audio, general-purpose	180	180	15	130	100	180	50	180	4	5		
2SC3835	Humidifier, DC-DC converter, general-purpose	200	120	7 (Pulse 14)	70	100	200	70	220	4	3		
2SC3851	Audio, PPC high voltage power supply, general-purpose	80	60	4	25	100	80	40	320	4	1		
2SC3851A	Audio, PPC high voltage power supply, general-purpose	100	80	4	25	100	100	40	320	4	1		
2SC3852	Solenoid/motor driver/series regulator, general-purpose	80	60	3	25	10	80	500		4	0.5		
2SC3852A	Solenoid/motor driver/series regulator, general-purpose	100	80	3	25	10	100	500		4	0.5		
2SC3856	Audio, general-purpose	200	180	15	130	100	200	80	180	4	3		
2SC3857	Audio, general-purpose	200	200	15	150	100	200	50	180	4	5		
2SC3858	Audio, general-purpose	200	200	17	200	100	200	50	180	4	8		
2SC3927	Switching regulator, general-purpose	900	550	10 (Pulse 15)	120	100	800	10	28	4	5		
2SC4024	DC-DC converter, emergency lamp inverter, general-purpose	100	50	10	35	100	100	300	1600	4	1		
2SC4131	DC-DC converter, emergency lamp inverter, general-purpose	100	50	15 (Pulse 20)	60	10	100	60	360	1	5		
2SC4138	Switching regulator, general-purpose	500	400	10 (Pulse 20)	80	100	500	10	30	4	6		
2SC4140	Switching regulator, general-purpose	500	400	18 (Pulse 36)	130	100	500	10	30	4	10		
2SC4153	Humidifier, DC-DC converter, general-purpose	200	120	7 (Pulse 14)	30	100	200	70	220	4	3		
2SC4300	Switching regulator, general-purpose	900	800	5 (Pulse 10)	75	100	800	10	30	4	2		
2SC4301	Switching regulator, lighting inverter, general-purpose	900	800	7 (Pulse 14)	80	100	800	10	30	4	3		
2SC4304	Switching regulator, general-purpose	900	800	3 (Pulse 6)	35	100	800	10	30	4	0.7		
2SC4381	TV vertical output, audio output driver, general-purpose	150	150	2	25	10	150	60		10	0.7		
2SC4382	TV vertical output, audio output driver, general-purpose	200	200	2	25	10	200	60		10	0.7		
2SC4388	Audio, general-purpose	200	180	15	85	10	200	50	180	4	3		
2SC4445	Switching regulator, general-purpose	900	800	3 (Pulse 6)	60	100	800	10	30	4	0.7		
2SC4466	Audio, general-purpose	120	80	6	60	10	120	50	180	4	2		
2SC4467	Audio, general-purpose	160	120	8	80	10	160	50	180	4	3		
2SC4468	Audio, general-purpose	200	140	10	100	10	200	50	180	4	3		
2SC4495	For audio temperature compensation, general-purpose	80	50	3	25	10	80	500		4	0.5		
2SC4511	Audio, general-purpose	120	80	6	30	10	120	50	180	4	2		
2SC4518	Switching regulator, lighting inverter, general-purpose	900	550	5 (Pulse 10)	35	100	800	10	25	4	1.8		
2SC4518A	Switching regulator, lighting inverter, general-purpose	1000	550	5 (Pulse 10)	35	100	800	10	25	4	1.8		
2SC4546	Switching regulator, lighting inverter, general-purpose	600	400	7 (Pulse 14)	30	100	600	10	25	4	3		
2SC4706	Switching regulator, general-purpose	900	600	14 (Pulse 28)	130	100	800	10	25	4	7		
2SC4883	Audio output driver, TV velocity modulation	150	150	2	20	10	150	60	240	10	0.7		
2SC4883A	Audio output driver, TV velocity modulation	180	180	2	20	10	180	60	240	10	0.7		
2SC4886	Audio, general-purpose	150	150	14	80	100	150	50	180	4	5		
2SC5071	Switching regulator, general-purpose	500	400	12 (Pulse 24)	100	100	500	10	30	4	7		
2SC5099	Audio, general-purpose	120	80	6	60	10	120	50	180	4	2		
2SC5100	Audio, general-purpose	160	120	8	75	10	160	50	180	4	3		
2SC5101	Audio, general-purpose	200	140	10	80	10	200	50	180	4	3		
2SC5130	Switching regulator, general-purpose	600	400	5 (Pulse 10)	30	100	500	10	30	4	1.5		
2SC5287	Switching regulator, general-purpose	900	550	5 (Pulse 10)	80	100	800	10	25	4	1.8		
2SC6011	Audio, general-purpose	200	200	15	160	10	200	50	180	4	3		
2SC6011A	Audio, general-purpose	230	230	15	160	10	230	50	180	4	3		
2SC6145	Audio, general-purpose	230	230	15	160	10	230	40	140	4	5		

Electrical Characteristics												Complementary	Package	Mass (g)
V _{CE} (sat)	V _{BE} (sat)	Conditions			f _T		Switching Time			C _{ob}				
(V)	(V)	I _c	I _b	MHz	V _{CE}	I _E	t _{on}	t _{stg}	t _r					
max	max	(A)	(A)		(V)	(A)	(μs)	(μs)	(μs)	(pF)				
2.0		5	0.5	70	12	-1	0.2typ	1.4typ	0.35typ	60typ	2SA1186	TO-3P (MT-100)	6.0	
2.0		5	0.5	60	12	-2	0.2typ	1.5typ	0.35typ	200typ	2SA1215	MT-200	18.4	
2.0		8	0.8	50	12	-2	0.2typ	1.3typ	0.45typ	250typ	2SA1216	MT-200	18.4	
2.0		5	0.5	60	12	-2	0.3typ	2.4typ	0.5typ	250typ	2SA1294	TO-3P (MT-100)	6.0	
2.0		5	0.5	60	12	-2	0.3typ	2.4typ	0.5typ	250typ	2SA1295	MT-200	18.4	
2.0		5	0.5	60	12	-2	0.2typ	1.5typ	0.35typ	200typ	2SA1303	TO-3P (MT-100)	6.0	
2.0		5	0.5	50	12	-2	0.2typ	1.3typ	0.45typ	250typ	2SA1386	TO-3P (MT-100)	6.0	
2.0		5	0.5	50	12	-2	0.2typ	1.3typ	0.45typ	250typ	2SA1386A	TO-3P (MT-100)	6.0	
0.5	1.2	3	0.3	30	12	-0.5	0.5max	3max	0.5max	110typ		TO-3P (MT-100)	6.0	
0.5		2	0.2	15	12	-0.2	0.2typ	1typ	0.3typ	60typ	2SA1488	TO-220F (FM20)	2.0	
0.5		2	0.2	15	12	-0.2	0.2typ	1typ	0.3typ	60typ	2SA1488A	TO-220F (FM20)	2.0	
0.5		2	0.05	15	12	-0.2	0.8typ	3typ	1.2typ	50typ		TO-220F (FM20)	2.0	
0.5		2	0.05	15	12	-0.2	0.8typ	3typ	1.2typ	50typ		TO-220F (FM20)	2.0	
2.0		5	0.5	20	12	-0.5	0.5typ	1.8typ	0.6typ	300typ	2SA1492	TO-3P (MT-100)	6.0	
3.0		10	1	20	12	-0.5	0.3typ	2.4typ	0.4typ	250typ	2SA1493	MT-200	18.4	
2.5		10	1	20	12	-1	0.5typ	1.8typ	0.6typ	300typ	2SA1494	MT-200	18.4	
0.5	1.2	5	1	6	12	-1	1max	5max	0.5max	105typ		TO-3P (MT-100)	6.0	
0.5		5	0.1	24	12	-0.5	0.5typ	2typ	0.5typ	150typ		TO-220F (FM20)	2.0	
0.5	1.2	5	0.08	18	12	-1	0.5typ	2typ	0.4typ	210typ		TO-3PF (FM100)	6.5	
0.5	1.3	6	1.2	10	12	-0.7	1max	3max	0.5max	85typ		TO-3P (MT-100)	6.0	
0.5	1.3	10	2	10	12	-2.0	1max	3max	0.5max	165typ		TO-3P (MT-100)	6.0	
0.5	1.2	3	0.3	30	12	-0.5	0.5max	3max	0.5max	110typ		TO-220F (FM20)	2.0	
0.5	1.2	2	0.4	6	12	-0.5	1max	5max	1max	75typ		TO-3PF (FM100)	6.5	
0.5	1.2	3	0.6	6	12	-1	1max	5max	1max	105typ		TO-3PF (FM100)	6.5	
0.5	1.2	7	0.14	15	12	-0.3	0.7max	4max	0.7max	50typ		TO-220F (FM20)	2.0	
1.0		7	0.07	15	12	-0.2	1typ	3typ	1.5typ	35	2SA1667	TO-220F (FM20)	2.0	
1.0		7	0.07	15	12	-0.2	1typ	3typ	1.5typ	35	2SA1668	TO-220F (FM20)	2.0	
2.0		5	0.5	20	12	-0.5	0.5max	1.8max	0.6max	300	2SA1673	TO-3PF (FM100)	6.5	
0.5	1.2	0.7	0.14	15	12	-0.3	0.7max	4max	0.7max	50		TO-3PF (FM100)	6.5	
1.5		2	0.2	20	12	-0.5	0.16typ	2.6typ	0.34typ	110	2SA1693	TO-3P (MT-100)	6.0	
1.5		3	0.3	20	12	-0.5	0.13typ	3.5typ	0.32typ	200	2SA1694	TO-3P (MT-100)	6.0	
0.5		5	0.5	20	12	-0.5	0.24typ	4.32typ	0.4typ	250	2SA1695	TO-3P (MT-100)	6.0	
0.5		4	0.02	40	12	-0.1	0.45typ	1.6typ	0.85typ	30		TO-220F (FM20)	2.0	
0.5		2	0.2	20	12	-0.5	0.16typ	2.6typ	0.34typ	110	2SA1725	TO-220F (FM20)	2.0	
0.5	1.2	1.8	0.36	6	12	-0.35	0.7max	4max	0.5max	50		TO-220F (FM20)	2.0	
0.5	1.2	1.8	0.36	6	12	-0.35	0.7max	4max	0.5max	50		TO-220F (FM20)	2.0	
0.7	1.3	3	0.6	10	12	-0.5	0.5max	2max	0.15max	55		TO-220F (FM20)	2.0	
0.5	1.2	7	1.4	6	12	-1.5	1max	5max	0.7max	160		TO-3P (MT-100)	6.0	
1.0		0.7	0.07	120	12	-0.7	0.5typ	1.5typ	0.5typ	30	2SA1859	TO-220F (FM20)	2.0	
1.0		0.7	0.07	120	12	-0.7	0.5typ	1.5typ	0.5typ	30	2SA1859A	TO-220F (FM20)	2.0	
2.0		5	0.5	60	12	-2	0.26typ	1.5typ	0.35typ	200	2SA1860	TO-3PF (FM100)	6.5	
0.5	1.3	7	1.4	10	12	-1	1max	3max	0.5max	105		TO-3P (MT-100)	6.0	
0.5		2	0.2	20	12	-0.5	0.16typ	2.6typ	0.34typ	110	2SA1907	TO-3PF (FM100)	6.5	
0.5		3	0.3	20	12	-0.5	0.13typ	3.5typ	0.32typ	200	2SA1908	TO-3PF (FM100)	6.5	
0.5		5	0.5	20	12	-0.5	0.24typ	4.32typ	0.4typ	250	2SA1909	TO-3PF (FM100)	6.5	
0.5	1.3	1.5	0.3	20	12	-0.3	1max	2max	0.3max	30		TO-220F (FM20)	2.0	
0.5	1.2	1.8	0.36	6	12	-0.35	0.7max	4max	0.5max	50		TO-3P (MT-100)	6.0	
0.5		5	0.5	20	12	-0.5	-	-	-	270	2SA2151	TO-3P (MT-100)	6.0	
0.5		5	0.5	20	12	-0.5	-	-	-	270	2SA2151A	TO-3P (MT-100)	6.0	
0.5		5	0.5	60	12	-2	-	-	-	250	2SA2223	TP-3P (MT-100)	6.0	

Part Number	Applications	Absolute Maximum Ratings				I _{CBO}		h _{FE}		Conditions	
		V _{CB0}	V _{CE0}	I _c	P _c	I _{CBO} (μ A)	Conditions V _{CB} (V)	min	max	Conditions	
		(V)	(V)	(A)	(W)					V _{CE} (V)	I _c (A)
2SD1785	Solenoid/relay/motor driver/series regulator, general-purpose	120	120	6 (Pulse 10)	30	10	120	2000		2	3
2SD1796	Solenoid/relay/motor driver, general-purpose	60 \pm 10	60 \pm 10	4	25	10	50	2000		4	3
2SD2014	Solenoid/relay/motor driver/series regulator, general-purpose	120	80	4	25	10	120	2000		2	3
2SD2015	Solenoid/relay/motor driver, general-purpose	150	120	4	25	10	150	2000		2	2
2SD2016	Igniter, relay, general-purpose	200	200	3	25	10	200	1000	15000	4	1
2SD2017	Solenoid/relay/motor driver, general-purpose	300	250	6	35	100	300	2000		2	2
2SD2045	Solenoid/motor driver, general-purpose	120	120	6 (Pulse 10)	50	10	120	2000		2	3
2SD2081	Solenoid/motor driver, general-purpose	120	120	10 (Pulse 15)	30	10	120	2000		4	5
2SD2082	Solenoid/motor driver, general-purpose	120	120	16 (Pulse 26)	75	10	120	2000		4	8
2SD2083	Solenoid/motor driver, general-purpose	120	120	25 (Pulse 40)	120	10	120	2000		4	12
2SD2141	Igniter, solenoid, motor driver, general-purpose	380 \pm 50	380 \pm 50	6 (Pulse 10)	35	10	330	1500		2	3
2SD2389	Audio, series regulator, general-purpose	160	150	8	80	100	160	5000	30000	4	6
2SD2390	Audio, series regulator, general-purpose	160	150	10	100	100	160	5000	30000	4	7
2SD2401	Audio, series regulator, general-purpose	160	150	12	150	100	160	5000	30000	4	7
2SD2438	Audio, series regulator, general-purpose	160	150	8	75	100	160	5000	30000	4	6
2SD2439	Audio, series regulator, general-purpose	160	150	10	80	100	160	5000	30000	4	7
2SD2560	Audio, series regulator, general-purpose	150	150	15	130	100	150	5000	30000	4	10
2SD2561	Audio, series regulator, general-purpose	150	150	17	200	100	150	5000	30000	4	10
2SD2562	Audio, series regulator, general-purpose	150	150	15	85	100	150	5000	30000	4	10
2SD2641	Series regulator, general-purpose	110	110	6	60	100	110	5000	30000	4	5
2SD2642	Series regulator, general-purpose	110	110	6	30	100	110	5000	30000	4	5
2SD2643	Series regulator, general-purpose	110	110	6	60	100	110	5000	30000	4	5
STD01N	Audio	150	150	10	100	100	150	5000	20000	4	6
STD01P	Audio	-150	-150	-10	100	-100	-150	5000	20000	-4	-6
STD03N	Audio	160	160	15	160	100	160	5000	20000	4	10
STD03P	Audio	-160	-160	-15	160	-100	-160	5000	20000	-4	-10

Electrical Characteristics													Complementary	Package	Mass (g)
V _{CE (sat)} (V) max	V _{BE (sat)} (V) max	Conditions		f _T MHz	Conditions		Switching Time			C _{ob} (pF)					
		I _c (A)	I _B (A)		V _{CE} (V)	I _E (A)	t _{on} (μS)	t _{stg} (μS)	t _f (μS)						
											2	3mA			
1.5		3	10mA	60	12	-0.2					45		TO-220F (FM20)	2.0	
1.5	2.0	3	3mA	75	12	-0.1					45	2SB1257	TO-220F (FM20)	2.0	
1.5	2.0	2	2mA	40	12	-0.1					40		TO-220F (FM20)	2.0	
1.5	2.0	1	1.5mA	90	12	-0.1					40		TO-220F (FM20)	2.0	
1.5	2.0	2	2mA	20	12	-1					65		TO-220F (FM20)	2.0	
1.5	2.0	3	3mA	50	12	-1					70		TO-3PF (FM100)	6.5	
1.5	2.0	5	5mA	60	12	-0.5					95	2SB1259	TO-220F (FM20)	2.0	
1.5	2.5	8	16mA	20	12	-1					210	2SB1382	TO-3PF (FM100)	6.5	
1.8	2.5	12	24mA	20	12	-1					340	2SB1383	TO-3P (MT-100)	6.0	
1.5		4	20mA	20	12	-0.5					95		TO-220F (FM20)	2.0	
2.5	3.0	6	6mA	80	12	-1					85	2SB1559	TO-3P (MT-100)	6.0	
2.5	3.0	7	7mA	55	12	-2					95	2SB1560	TO-3P (MT-100)	6.0	
2.5	3.0	7	7mA	55	12	-2					95	2SB1570	MT-200	18.4	
2.5	3.0	6	6mA	80	12	-1					85	2SB1587	TO-3PF (FM100)	6.5	
2.5	3.0	7	7mA	55	12	-2					95	2SB1588	TO-3PF (FM100)	6.5	
2.5	3.0	10	10mA	70	12	-2					120	2SB1647	TO-3P (MT-100)	6.0	
2.5	3.0	10	10mA	70	12	-2					120	2SB1648	MT-200	18.4	
2.5	3.0	10	10mA	70	12	-2					120	2SB1649	TO-3PF (FM100)	6.5	
2.5	3.0	5	5mA	60	12	-2					55		TO-3P (MT-100)	6.0	
2.5	3.0	5	5mA	60	12	-0.5					55		TO-220F (FM20)	2.0	
2.5	3.0	5	5mA	60	12	-0.5					55		TO-3PF (FM100)	6.5	
2.0	2.5	6	6mA									STD01P	TO3P-5Pin	6.2	
-2.0	-2.5	-6	-6mA									STD01N	TO3P-5Pin	6.2	
2.0	2.5	10	10mA									STD03P	TO-3P-5pin	6.2	
-2.0	-2.5	-10	-10mA									STD03N	TO-3P-5pin	6.2	

Selection Guide

By V_{DSS}

V_{DSS} (V)	$R_{DS(ON)}$ (Ω) max	I_D (A)	P_D (W)	Part Number	Package
40	3.6m	± 100	100	SKH04100	TO263 (Surface-mount)
	3.8m	± 100	100	EKH04100	TO220
	3.8m	± 70	40	FKH0470	TO220F-A
	6.0m	± 70	80	2SK3800	TO220S (Surface-mount)
	6.0m	± 70	100	2SK3801	TO3P (MT100)
50	9m	± 60	60	FKV460S	TO220S (Surface-mount)
	10m	± 75	40	FKV575	TO220F (FM20)
	15m	± 50	35	FKV550N	TO220F (FM20)
60	15m	± 50	85	EKV550	TO220
	4.8m	± 100	100	SKH06100	TO263 (Surface-mount)
	5.0m	± 100	100	EKH06100	TO220
	5.0m	± 60	40	FKH0660	TO220F-A
	6.0m	± 70	90	2SK3710	TO220S (Surface-mount)
	6.0m	± 70	130	2SK3711	TO3P (MT100)
100	14m	± 60	60	FKV660S	TO220S (Surface-mount)
	28m	± 30	40	2SK2420	TO220F (FM20)
	11.3m	± 70	100	SKH1070	TO263 (Surface-mount)
	11.5m	± 70	100	EKH1070	TO220
	11.5m	± 40	40	FKH1040	TO220F-A
200	52m	± 20	55	EKG1020	TO220
	52m	± 20	40	FKG1020	TO220F-A
	53m	± 45	40	FKP202	TO220F (FM20)
	53m	± 45	95	SKP202	TO263 (Surface-mount)
250	0.175	± 18	35	2SK3003	TO220F (FM20)
	43m	± 50	85	FKP250A	TO3PF (FM100)
	75m	± 25	40	FKP252	TO220F (FM20)
	95m	± 20	40	FKP253	TO220F (FM20)
	95m	± 20	90	SKP253	TO263 (Surface-mount)
280	0.25	± 18	35	2SK3004	TO220F (FM20)
300	53m	± 40	85	FKP280A	TO3PF (FM100)
330	65m	± 30	85	FKP300A	TO3PF (FM100)
450	63m	± 30	85	FKP330C	TO3PF (FM100)
	1.1	± 7	35	2SK2701A	TO220F (FM20)
500	2.8	± 3	30	2SK2803	TO220F (FM20)
	0.27	± 20	150	MKS5020	TO3P
	0.4	± 15	150	MKS5015	TO3P
600	1.5	± 5	30	2SK3199	TO220F (FM20)
	3.8	± 2	30	2SK2848	TO220F (FM20)
900	5.0	± 3	30	2SK2943	TO220F (FM20)

Specifications List by Part Number

Part Number	Absolute Maximum Ratings						I _{GSS}		I _{BSS}		V _{TH}				
	V _{DSS}	V _{GSS}	I _D	I _{D (pulse)}	P _D	E _{AS}	Conditions	Conditions	min	max	min	max	Conditions		
	(V)	(V)	(A)	(A)	(W)	(mJ)							(nA)	(V _{GSS})	(V)
							max	(V)						(V)	(μA)
2SK2420	60	±20	±30	±120	40	38	±100	±20		100	60	2.0	4.0	10	250
2SK2701A	450	±30	±7	±28	35	130	±100	±30		100	450	2.0	4.0	10	1m
2SK2803	450	±30	±3	±12	30	30	±100	±30		100	450	2.0	4.0	10	1m
2SK2848	600	±30	±2	±8	30	10	±100	±30		100	600	2.0	4.0	10	250
2SK2943	900	±30	±3	±12	30	60	±100	±30		100	900	2.0	4.0	10	1m
2SK3003	200	±20	±18	±72	35	120	±100	±20		100	200	2.0	4.0	10	1m
2SK3004	250	±20	±18	±72	35	120	±100	±20		100	250	2.0	4.0	10	1m
2SK3199	500	±30	±5	±20	30	35	±100	±30		100	500	2.0	4.0	10	1m
2SK3710	60	±20	±70	±140	90	468	±10μ	±15		100	60	2.0	4.0	10	1m
2SK3711	60	±20	±70	±140	130		±10μ	+15		100	60	2.0	4.0	10	1m
2SK3800	40	±20	±70	±140	80	400	±10	±15		100	40	2.0	4.0	10	1m
2SK3801	40	±20	±70	±140	100	400	±10	±15		100	40	2.0	4.0	10	1m
EKG1020	100	±20	±20	±60	55	50	±10μ	±20		100	100	1.5	2.5	10	1m
EKH04100	40	±20	±100	±200	100	300	±20μ	±15		100	40	2.0	4.0	10	1m
EKH06100	60	±20	±100	±200	100	300	±20μ	±15		100	60	2.0	4.0	10	1m
EKH1070	100	±20	±70	±200	100	300	±20μ	±15		100	100	2.0	4.0	10	1m
EKV550	50	±20	±50	±150	85	150	±10μ	±20		100	50	3.0	4.2	10	250
FKG1020	100	±20	±20	±60	40	50	±10μ	±20		100	100	1.5	2.5	10	1m
FKH0470	40	±20	±70	±200	40	300	±20μ	±15		100	40	2.0	4.0	10	1m
FKH0660	60	±20	±60	±200	40	300	±20μ	±15		100	60	2.0	4.0	10	1m
FKH1040	100	±20	±40	±200	40	300	±20μ	±15		100	100	2.0	4.0	10	1m
FKP202	200	±30	±45	±180	40	200	±100	±30		100	200	3.0	4.5	10	1m
FKP250A	250	±30	±50	±200	85	400	±100	±30		100	250	3.0	4.5	10	1m
FKP252	250	±30	±25	±100	40	200	±100	±30		100	250	3.0	4.5	10	1m
FKP253	250	±30	±20	±80	40	160	±100	±30		100	250	3.0	4.5	10	1m
FKP280A	280	±30	±40	±160	85	400	±100	±30		100	280	3.0	4.5	10	1m
FKP300A	300	±30	±30	±120	85	400	±100	±30		100	300	3.0	4.5	10	1m
FKP330C	330	±30	±30	±120	85	500	±100	±30		100	330	3.0	4.5	10	1m
FKV460S	40	+20, -10	±60	±180	60		+10, -5μ	+20, -10		100	40	1.0	2.5	10	250
FKV550N	50	±20	±50	±150	35	150	±10μ	±20		100	50	3.0	4.2	10	250
FKV575	50	±20	±75	±200	40	300	±100	±20		100	50	3.0	4.5	10	250
FKV660S	60	+20, -10	±60	±180	60		+10, -5μ	+20, -10		100	60	1.0	2.5	10	250
MKS5015	500	±30	±15	±30	150	125	±100	±30		100	500	2.0	4.0	10	1m
MKS5020	500	±30	±20	±40	150	200	±100	±30		100	500	2.0	4.0	10	1m
SKH04100	40	±20	±100	±200	100	300	±20μ	±15		100	40	2.0	4.0	10	1m
SKH06100	60	±20	±100	±200	100	300	±20μ	±15		100	60	2.0	4.0	10	1m
SKH1070	100	±20	±70	±200	100	300	±20μ	±15		100	100	2.0	4.0	10	1m
SKP202	200	±30	±45	±180	95	200	±100	±30		100	200	3.0	4.5	10	1m
SKP253	250	±30	±20	±80	40	160	±100	±30		100	250	3.0	4.5	10	1m

Electrical Characteristics																	Package	Mass (g)
R _e (yfs)		Conditions		C _{iss} (pF)	C _{rss} (pF)	Conditions		R _{DS(ON)}										
								(S)		(Ω)		Conditions		(Ω)		Conditions		
min	typ	V _{DS} (V)	I _D (A)	typ	typ	V _{GS} (V)	V _{DS} (V)	typ	max	V _{GS} (V)	I _D (A)	typ	max	V _{GS} (V)	I _D (A)			
13	20	10	15	2200		0	25	21m	28m	10	15					TO220F(FM20)	2.0	
3.5	5	20	3.5	720	62	0	10	0.84	1.1	10	3.5					TO220F(FM20)	2.0	
1.5	2.1	20	1.5	340	26	0	10	2.1	2.8	10	1.5					TO220F(FM20)	2.0	
1.2	1.7	20	1	290	30	0	10	3	3.8	10	1					TO220F(FM20)	2.0	
1.8	2.8	20	1.5	600	40	0	10	4	5	10	1.5					TO220F(FM20)	2.0	
7	11	10	9	850	250	0	10	130m	175m	10	9					TO220F(FM20)	2.0	
7	11	10	9	850	250	0	10	0.2	0.25	10	9					TO220F(FM20)	2.0	
3.5	5.2	20	2.5	650	110	0	10	1.2	1.5	10	2.5					TO220F(FM20)	2.0	
30	80	10	35	8000	1000	0	10	5m	6m	10	35					TO220S(Surface-mount)	1.5	
30	80	10	35	8000	1000	0	10	5m	6m	10	35					TO3P(MT100)	6.0	
30	50	10	35	5100	860	0	10	5m	6m	10	35					TO220S(Surface-mount)	1.5	
30	50	10	35	5100	860	0	10	5m	6m	10	35					TO3P(MT100)	6.0	
9		10	10	2200	210	0	10	41m	52m	10	10	45m	49m	4.5	10	TO220	2.0	
	140	10	50	11500	1800	0	10	3m	3.8m	10	50					TO220	2.0	
	140	10	50	11500	1100	0	10	3.8m	5m	10	50					TO220	2.0	
	120	10	35	11500	780	0	10	8.8m	11.5m	10	35					TO220	2.0	
17		10	25	2000	500	0	10	12m	15m	10	25					TO220	2.0	
9		10	10	2200	210	0	10	41m	52m	10	10	45m	49m	4.5	10	TO220F-A	2.0	
	140	10	50	11500	1800	0	10	3m	3.8m	10	50					TO220F-A	2.0	
	140	10	50	11500	1100	0	10	3.8m	5m	10	50					TO220F-A	2.0	
	120	10	35	11500	780	0	10	8.8m	11.5m	10	35					TO220F-A	2.0	
18	28	10	22	2000	80	0	25	45m	53m	10	22					TO220F(FM20)	2.0	
30	42	10	25	3800	210	0	25	37m	43m	10	25					TO3PF(FM100)	6.5	
13	21	10	12	2000	70	0	25	68m	75m	10	12					TO220F(FM20)	2.0	
8	17	10	10	1600	50	0	25	86m	95m	10	10					TO220F(FM20)	2.0	
25	38	10	20	3800	190	0	25	46m	53m	10	20					TO3PF(FM100)	6.5	
20	33	10	15	3800	180	0	25	57m	65m	10	15					TO3PF(FM100)	6.5	
23	37	10	15	4600	220	0	25	50m	63m	10	15					TO3PF(FM100)	6.5	
20		10	25	2800	600	0	10	7m	9m	10	25					TO220S(Surface-mount)	1.5	
17		10	25	2000	500	0	10	12m	15m	10	25					TO220F(FM20)	2.0	
30		10	37	3200	750	0	10	7m	10m	10	37					TO220F(FM20)	2.0	
20		10	25	2500	150	0	10	11m	14m	10	25					TO220S(Surface-mount)	1.5	
4		10	7.5	2000	900	0	10	0.3	0.4	10	7.5					TO3P	6.0	
4		10	10	3300	1500	0	10	0.21	0.27	10	10					TO3P	6.0	
	140	10	50	11500	1800	0	10	2.8m	3.6m	10	50					TO263(Surface-mount)	1.5	
	140	10	50	11500	1100	0	10	3.6m	4.8m	10	50					TO263(Surface-mount)	1.5	
	120	10	35	11500	780	0	10	8.6m	11.3m	10	35					TO263(Surface-mount)	1.5	
18	28	10	22	2000	80	0	25	45m	53m	10	22					TO263(Surface-mount)	1.5	
8	17	10	10	1600	50	0	25	86m	95m	10	10					TO263(Surface-mount)	1.5	

Selection Guide

By V_{CES}

V_{CES} (V)	I_C (A)	P_C (W)	Part Number	Package
600	25	60	FGM622S	TO3PF(FM100)
	30	60	FGM603	TO3PF(FM100)
	30	60	FGM623S	TO3PF(FM100)
	50	150	MGD623N	TO3P(MT100)
	50	150	MGD623S	TO3P(MT100)

Specifications List by Part Number

Part Number	Absolute Maximum Ratings (Ta=25°C)																							
	V _{CES} (V)	V _{GE} (V)	I _c (A)	I _{c(pulse)} (A)	P _c (Ta=25°C) (W)	I _{GES}		I _{CES}		V _{GE(th)}				V _{CE(sat)}				C _{ies}	C _{oes}	C _{res}	Conditions			
						(nA)	V _{GE} (V)	(μA)	V _{CE} (V)	(V)	I _c (mA)	V _{CE} (V)	(V)	I _c (A)	V _{GE} (V)	(pF)	(pF)	(pF)	V _{CE} (V)	V _{GE} (V)				
																					max	max	min	max
FGM603	600	±20	30	90	60	±100	±20	100	600	4	7	1	10	1.6	2.0	30	15	4600	110	80	20	0		
FGM622S	600	±30	25	75	60	±500	±30	100	600	4	7	1	10	1.7	1.9	25	15	1300	80	40	20	0		
FGM623S	600	±30	30	100	60	±500	±30	100	600	3	6	1	10	1.5	1.7	30	15	2500	150	80	20	0		
MGD623N	600	±30	50	100	150	±100	±30	100	600	3	6	1	10	1.7	2.3	50	15	2500	150	80	20	0		
MGD623S	600	±30	50	100	150	±100	±30	100	600	3	6	1	10	1.8	2.4	50	15	2500	150	80	20	0		

Electrical Characteristics (Ta=25°C)																				Package	Mass (g)	
td(on)	tr	td(off)	tf	Conditions			Qg	Qge	Qgc	Conditions			VF		Conditions	trr			Package			Mass (g)
(ns)	(ns)	(ns)	(ns)	Ic	VCE		(nC)	(nC)	(nC)	Ic	VCE	VGE	(V)		IF	(μs)	IF	di/dt				
typ	typ	typ	typ	(A)	(V)		typ	typ	typ	(A)	(V)	(V)	typ	max	(A)	typ	(A)	(A/μs)				
130	70	340	200	30	300	L Load	120	30	30	30	300	15								TO3PF(FM100)	6.5	
50	60	200	120	25	300	L Load	40	10	10	25	300	15								TO3PF(FM100)	6.5	
100	80	300	120	30	300	L Load	65	20	20	30	300	15								TO3PF(FM100)	6.5	
75	70	250	200	50	300	L Load	65	15	20	50	300	15	1.2	1.6	30	0.3	30	100		TO3P(MT100)	6.0	Built-in Di
75	70	250	120	50	300	L Load	65	15	20	50	300	15	1.2	1.6	30	0.3	30	100		TO3P(MT100)	6.0	Built-in Di

2-4 Transistor and MOS FET Arrays

Specifications List by Part Number

Part Number	Category	Circuit Count	$V_{CE0} \cdot V_{DSS} \cdot V_{CES}$ (V)	$I_C \cdot I_D$ (A)	hFE (min)	$R_{DS(ON)}$ max(Ω)	Package	Mass (g)
SLA4030	For sink driver	4	100	4	2000		SIP12 with Fin (SLA12Pin)	6.0
SLA4031	For sink driver	4	120	4	2000		SIP12 with Fin (SLA12Pin)	6.0
SLA4036	For sink driver	6	120	2	2000		SIP15 with Fin (SLA15Pin)	6.0
SLA4041	For sink driver	4	200	3	1000		SIP12 with Fin (SLA15Pin)	6.0
SLA4051	For sink driver	9	120	2	2000		SIP21 with Fin (SLA21Pin)	6.0
SLA4052	For sink driver	9	120	3	2000		SIP21 with Fin (SLA21Pin)	6.0
SLA4060	For sink driver	4	120	5	2000		SIP12 with Fin (SLA12Pin)	6.0
SLA4061	For sink driver	4	120	5	2000		SIP12 with Fin (SLA12Pin)	6.0
SLA4070	For source driver	4	-100	-5	1000		SIP12 with Fin (SLA12Pin)	6.0
SLA4071	For source driver	4	-100	-5	2000		SIP12 with Fin (SLA12Pin)	6.0
SLA4390	H bridge	4	± 100	± 5	2000		SIP12 with Fin (SLA12Pin)	6.0
SLA5037	For sink driver	4	100	10		0.08	SIP12 with Fin (SLA12Pin)	6.0
SLA5041	For sink driver	4	200	10		0.175	SIP12 with Fin (SLA12Pin)	6.0
SLA5059	For 3-phase motor driver	6	± 60	± 4		0.55	SIP12 with Fin (SLA12Pin)	6.0
SLA5060	For 3-phase motor driver	6	± 60	± 6		0.22	SIP12 with Fin (SLA12Pin)	6.0
SLA5061	For 3-phase motor driver	6	± 60	± 10		0.14	SIP12 with Fin (SLA12Pin)	6.0
SLA5064	For 3-phase motor driver	6	± 60	± 10		0.14	SIP12 with Fin (SLA12Pin)	6.0
SLA5065	For 5-phase motor driver	4	60	7		0.1	SIP15 with Fin (SLA15Pin)	6.0
SLA5068	For 5-phase motor driver	6	60	7		0.1	SIP15 with Fin (SLA15Pin)	6.0
SLA5073	For 5-phase motor driver	6	60	5		0.3	SIP15 with Fin (SLA15Pin)	6.0
SLA5074	For 5-phase motor driver	4	60	5		0.3	SIP15 with Fin (SLA15Pin)	6.0
SLA5075	For 3-phase motor driver	6	500	± 5		1.4	SIP15 with Fin (SLA15Pin)	6.0
SLA5085	For sink driver	5	60	5		0.22	SIP12 with Fin (SLA12Pin)	6.0
SLA5086	For source driver	5	-60	-5		0.22	SIP12 with Fin (SLA12Pin)	6.0
SLA5096	For 3-phase motor driver	6	55	8		0.08	SIP15 with Fin (SLA15Pin)	6.0
SLA5201	For 3-phase motor driver	6	600	7		1.85Vtyp($V_{CE(sat)}$)	SIP15 with Fin (SLA15Pin)	6.0
SLA5212	For 3-phase motor driver	6	35	± 8		0.07	SIP15 with Fin (SLA15Pin)	6.0
SLA5222	For Partial switching PFC	1+Di \times 4	600	30		1.3Vtyp($V_{CE(sat)}$)	SIP12 with Fin (SLA12Pin)	6.0
SLA5227	For Partial switching PFC	1+Di \times 4	600	30		1.3Vtyp($V_{CE(sat)}$)	SIP12 with Fin (SLA12Pin)	6.0
SLA6012	For 3-phase motor driver	6	± 60	± 4	2000		SIP12 with Fin (SLA12Pin)	6.0
SLA6020	For 3-phase motor driver	6	± 100	± 5	2000		SIP12 with Fin (SLA12Pin)	6.0
SLA6022	For 3-phase motor driver	6	± 80	± 5	2000		SIP12 with Fin (SLA12Pin)	6.0
SLA6023	For 3-phase motor driver	6	± 60	± 6	2000		SIP12 with Fin (SLA12Pin)	6.0
SLA6024	For 3-phase motor driver	6	± 60	± 8	2000		SIP12 with Fin (SLA12Pin)	6.0
SLA6026	For 3-phase motor driver	6	± 60	± 10	2000		SIP12 with Fin (SLA12Pin)	6.0

Part Number	Category	Circuit Count	$V_{CE0} \cdot V_{DSS} \cdot V_{CES}$ (V)	$I_C \cdot I_D$ (A)	hFE (min)	$R_{DS(ON)}$ max(Ω)	Package	Mass (g)
SMA4020	For source driver	4	-60	-4	2000		SIP12 (SMA12Pin)	4.0
SMA4021	For source driver	4	-60	-3	2000		SIP12 (SMA12Pin)	4.0
SMA4030	For sink driver	4	100	3	2000		SIP12 (SMA12Pin)	4.0
SMA4032	For sink driver	4	100	3	2000		SIP12 (SMA12Pin)	4.0
SMA4033	For sink driver	4	100	2	2000		SIP12 (SMA12Pin)	4.0
SMA4036	For sink driver	6	120	2	2000		SIP15 (SMA15Pin)	4.0
SMA4038	For sink driver	6	120	3	2000		SIP15 (SMA15Pin)	4.0
SMA5106	For sink driver	4	100	4		0.55	SIP12 (SMA12Pin)	4.0
SMA5112	For 3-phase motor driver	6	250	7		0.5	SIP12 (SMA12Pin)	4.0
SMA5117	For 3-phase motor driver	6	250	7		0.25	SIP12 (SMA12Pin)	4.0
SMA5118	For 3-phase motor driver	6	500	± 5		1.4	SIP12 (SMA12Pin)	4.0
SMA5125	For 3-phase motor driver	6	± 60	± 10		0.14	SIP12 (SMA12Pin)	4.0
SMA5127	For 3-phase motor driver	6	± 60	± 4		0.55	SIP12 (SMA12Pin)	4.0
SMA5130	For 3-phase motor driver	6	250	2.5	2000	0.9	SIP15 (SMA15Pin)	4.0
SMA5131	For 3-phase motor driver	6	250	2		1.8	SIP12 (SMA12Pin)	4.0
SMA5132	For 3-phase motor driver	6	500	1.5		4	SIP12 (SMA12Pin)	4.0
SMA5133	For 3-phase motor driver	6	500	2.5		2	SIP12 (SMA12Pin)	4.0
SMA6010	For 3-phase motor driver	6	± 60	± 4	2000		SIP12 (SMA12Pin)	4.0
SMA6080	For 3-phase motor driver	6	± 60	± 2	2000		SIP12 (SMA12Pin)	4.0
SMA6511	For driving stepping motor with two supplies	5	$100 \pm 15 / -60$	$1.5 / -3$	2000		SIP12 (SMA12Pin)	4.0
STA301A	For sink driver	3	60 ± 10	4	1000		SIP8 (STA8Pin)	2.0
STA302A	For source driver/3-phase motor driver	3	-50	-4	1000		SIP8 (STA8Pin)	2.0
STA303A	For sink driver/3-phase motor driver	3	100	4	1000		SIP8 (STA8Pin)	2.0
STA322A	For source driver	3	-50	-3	100		SIP8 (STA8Pin)	2.0
STA401A	For sink driver	4	60 ± 10	4	1000		SIP10 (STA10Pin)	2.6
STA402A	For source driver	4	-50	-4	1000		SIP10 (STA10Pin)	2.6
STA403A	For sink driver	4	100	4	1000		SIP10 (STA10Pin)	2.6
STA404A	For sink driver	4	200	3	1000		SIP10 (STA10Pin)	2.6
STA406A	For sink driver	4	60 ± 10	6	2000		SIP10 (STA10Pin)	2.6
STA408A	For source driver	4	-120	-4	2000		SIP10 (STA10Pin)	2.6
STA412A	For sink driver	4	60	3	300		SIP10 (STA10Pin)	2.6
STA413A	For sink driver	4	35 ± 5	3	500		SIP10 (STA10Pin)	2.6
STA421A	For source driver	4	-60	-3	40		SIP10 (STA10Pin)	2.6
STA431A	H bridge	4	± 60	± 3	40		SIP10 (STA10Pin)	2.6
STA434A	H bridge	4	± 60	± 4	1000		SIP10 (STA10Pin)	2.6
STA457C	H bridge	4	± 60	± 4	2000		SIP10 (STA10Pin)	2.6
STA460C	For sink driver	2	60 ± 10	6	700		SIP10 (STA10Pin)	2.6
STA471A	For sink driver	4	60 ± 10	2	2000		SIP10 (STA10Pin)	2.6
STA472A	For source driver	4	-60	-2	2000		SIP10 (STA10Pin)	2.6
STA473A	For sink driver	4	100	2	2000		SIP10 (STA10Pin)	2.6
STA475A	For sink driver	4	100 ± 15	2	2000		SIP10 (STA10Pin)	2.6
STA481A	For sink driver	4	60 ± 10	1	2000		SIP10 (STA10Pin)	2.6
STA485A	For sink driver	4	100 ± 15	1	2000		SIP10 (STA10Pin)	2.6

Specifications List by Application Sink Driver Arrays

● Built-in Avalanche Diodes, between Collector and Base

Part Number	Circuit Count	V _{CE0} (V)/ V _{DSS} (V)	I _C (A)/ I _D (A)	h _{FE} (min)	R _{DS(ON)} max (Ω)	Equivalent Circuit	Package
STA460C	2	60±10	6	700		1	SIP10 (STA10Pin)
STA301A	3	60±10	4	1000		2	SIP8 (STA8Pin)
STA413A	4	35±5	3	500		3	SIP10 (STA10Pin)
STA481A	4	60±10	1	2000		4	SIP10 (STA10Pin)
STA471A	4	60±10	2	2000		4	SIP10 (STA10Pin)
STA401A	4	60±10	4	1000		4	SIP10 (STA10Pin)
STA406A	4	60±10	6	2000		4	SIP10 (STA10Pin)
STA485A	4	100±15	1	2000		4	SIP10 (STA10Pin)
STA475A	4	100±15	2	2000		4	SIP10 (STA10Pin)

● Built-in Flywheel Diodes

Part Number	Circuit Count	V _{CE0} (V)/ V _{DSS} (V)	I _C (A)/ I _D (A)	h _{FE} (min)	R _{DS(ON)} max (Ω)	Equivalent Circuit	Package
SMA4033	4	100	2	2000		6	SIP12 (SMA12Pin)
SMA4032	4	100	3	2000		6	SIP12 (SMA12Pin)
SMA5106	4	100	4		0.55	5	SIP12 (SMA12Pin)
SLA4031	4	120	4	2000		6	SIP12 with Fin (SLA12Pin)
SLA4061	4	120	5	2000		6	SIP12 with Fin (SLA12Pin)
SLA4041	4	200	3	1000		6	SIP12 with Fin (SLA12Pin)
SMA4036	6	120	2	2000		7	SIP15 (SMA15Pin)
SLA4036	6	120	2	2000		7	SIP15 with Fin (SLA15Pin)
SMA4038	6	120	3	2000		7	SIP15 (SMA15Pin)
SLA4051	9	120	2	2000		8	SIP12 with Fin (SLA12Pin)
SLA4052	9	120	3	2000		8	SIP12 with Fin (SLA12Pin)

● General-Purpose

Part Number	Circuit Count	V _{CE0} (V)/ V _{DSS} (V)	I _C (A)/ I _D (A)	h _{FE} (min)	R _{DS(ON)} max (Ω)	Equivalent Circuit	Package
STA303A	3	100	4	100		9	SIP8 (STA8Pin)
STA412A	4	60	3	300		10	SIP10 (STA10Pin)
STA473A	4	100	2	2000		14	SIP10 (STA10Pin)
SMA4030	4	100	3	2000		12	SIP12 (SMA12Pin)
STA403A	4	100	4	1000		14	SIP10 (STA10Pin)
SLA4030	4	100	4	2000		12	SIP12 with Fin (SLA12Pin)
SLA5037	4	100	10		0.08	11	SIP12 with Fin (SLA12Pin)
SLA4060	4	120	5	2000		12	SIP12 with Fin (SLA12Pin)
STA404A	4	200	3	1000		14	SIP10 (STA10Pin)
SLA5041	4	200	10		0.175	11	SIP12 with Fin (SLA12Pin)
SLA5085	5	60	5		0.22	13	SIP12 with Fin (SLA12Pin)

●Equivalent Circuit (for Sink Driver)

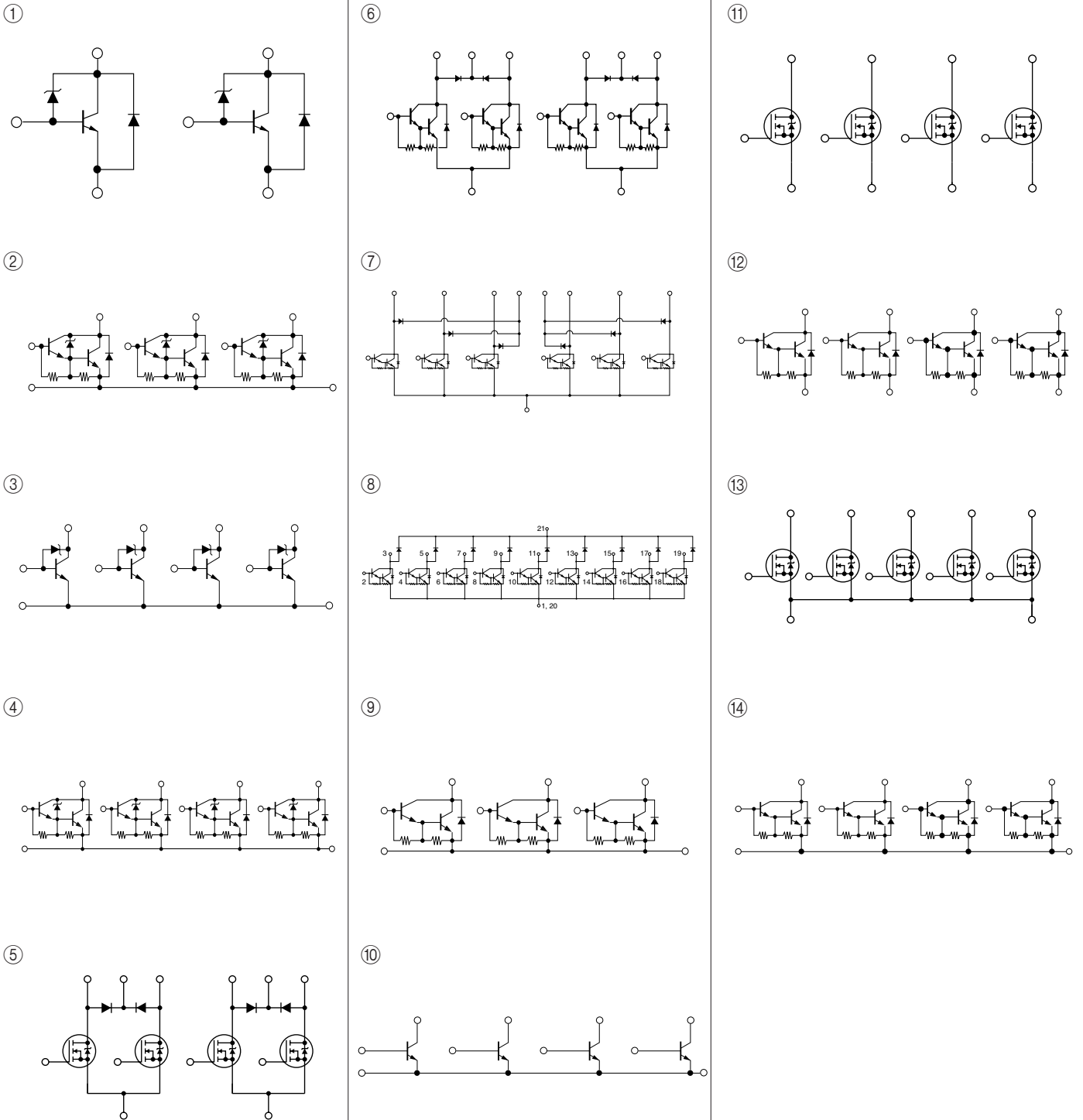

Specifications List by Application Source Driver Arrays

●Built-in Flywheel Diodes

Part Number	Circuit Count	V _{CEO} (V)/ V _{DSS} (V)	I _c (A)/ I _D (A)	h _{FE} (min)	R _{DS(ON)} max (Ω)	Equivalent Circuit	Package
SMA4021	4	-60	-3	2000		1	SIP12 (SMA12Pin)
SLA4071	4	-100	-5	2000		1	SIP12 with Fin (SLA12Pin)

●General-Purpose

Part Number	Circuit Count	V _{CEO} (V)/ V _{DSS} (V)	I _c (A)/ I _D (A)	h _{FE} (min)	R _{DS(ON)} max (Ω)	Equivalent Circuit	Package
STA322A	3	-50	-3	100		2	SIP8 (STA8Pin)
STA302A	3	-50	-4	1000		3	SIP8 (STA8Pin)
STA402A	4	-50	-4	1000		4	SIP10 (STA10Pin)
STA472A	4	-60	-2	2000		4	SIP10 (STA10Pin)
STA421A	4	-60	-3	40		6	SIP10 (STA10Pin)
SMA4020	4	-60	-4	2000		5	SIP12 (SMA12Pin)
SLA4070	4	-100	-5	1000		5	SIP12 with Fin (SLA12Pin)
STA408A	4	-120	-4	2000		7	SIP10 (STA10Pin)
SLA5086	5	-60	-5		0.22	8	SIP12 with Fin (SLA12Pin)

●Equivalent Circuit (for Source Driver)

①

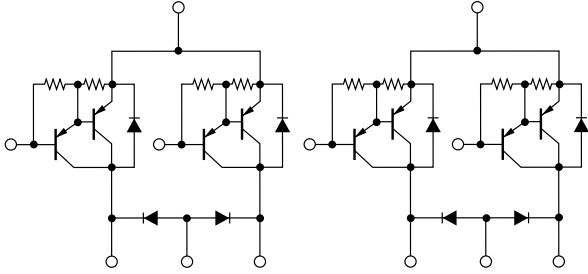

②

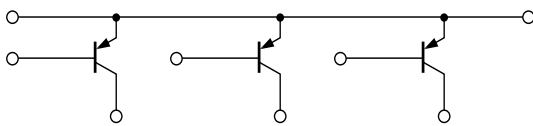

③



④

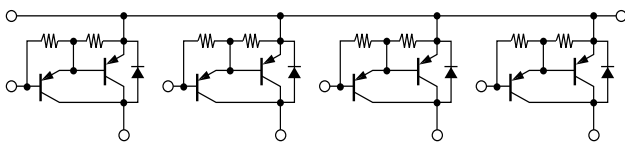

⑤

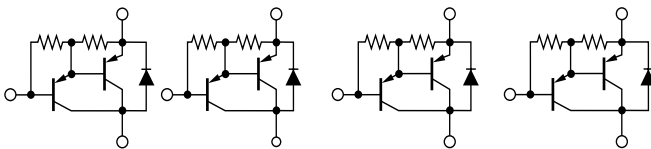

⑥



⑦



⑧



Specifications List by Application *Motor Driver Arrays*
●H Bridge

Part Number	Circuit Count	V _{CE0} (V)/ V _{DSS} (V)	I _C (A)/ I _D (A)	h _{FE} (min)	R _{DS(ON)} max (Ω)	Equivalent Circuit	Package
STA431A	4	±60	±3	40		1	SIP10 (STA10Pin)
STA434A	4	±60	±4	1000		2	SIP10 (STA10Pin)
STA457C	4	±60	±4	2000		3	SIP10 (STA10Pin)
SLA4390	4	±100	±5	2000		2	SIP12 with Fin (SLA12Pin)

●Equivalent Circuit (for Motor Driver)

①



②



③



●For 3-Phase Motor Drivers

Part Number	Circuit Count	V _{CE0} (V)/ V _{DSS} (V)/ V _{CEs} (V)	I _c (A)/ I _D (A)	h _{FE} (min)	R _{Ds(ON)} max (Ω)	Equivalent Circuit	Package
STA303A	3	100	4	1000		4	SIP8 (STA8Pin)
STA302A	3	-50	-4	1000		5	SIP8 (STA8Pin)
SLA5212	6	35	±8		70m	13	SIP15 with Fin (SLA15Pin)
SLA5096	6	55	±8		80m	13	SIP15 with Fin (SLA15Pin)
SLA5059	6	60	±4		0.55	6	SIP12 with Fin (SLA12Pin)
SLA5060	6	60	±6		0.22	6	SIP12 with Fin (SLA12Pin)
SLA5061	6	60	±10		0.14	6	SIP12 with Fin (SLA12Pin)
SLA5064	6	60	±10		0.14	7	SIP12 with Fin (SLA12Pin)
SMA6080	6	±60	±2	2000		9	SIP12 (SMA12Pin)
SMA6010	6	±60	±4	2000		9	SIP12 (SMA12Pin)
SLA6012	6	±60	±4	2000		8	SIP12 with Fin (SLA12Pin)
SMA5127	6	±60	±4		0.55	10	SIP12 (SMA12Pin)
SLA6023	6	±60	±6	2000		8	SIP12 with Fin (SLA12Pin)
SLA6024	6	±60	±8	2000		8	SIP12 with Fin (SLA12Pin)
SLA6026	6	±60	±10	2000		8	SIP12 with Fin (SLA12Pin)
SMA5125	6	±60	±10		0.14	7	SIP12 (SMA12Pin)
SLA6022	6	±80	±5	2000		8	SIP12 with Fin (SLA12Pin)
SLA6020	6	±100	±5	2000		9	SIP12 with Fin (SLA12Pin)
SMA5130	6	±250	±2.5	2000	0.9	15	SIP15 (SMA15Pin)
SMA5131	6	250	2		1.8	12	SIP12 (SMA12Pin)
SMA5112	6	250	7		0.5	12	SIP12 (SMA12Pin)
SMA5117	6	250	7		0.25	12	SIP12 (SMA12Pin)
SMA5132	6	500	1.5		4	12	SIP12 (SMA12Pin)
SMA5133	6	500	2.5		2	12	SIP12 (SMA12Pin)
SLA5075	6	500	±5		1.4	11	SIP15 with Fin (SLA15Pin)
SMA5118	6	500	±5		1.4	12	SIP12 (SMA12Pin)
SLA5201	6	600	7			14	SIP15 with Fin (SLA15Pin)

●For Driving Stepping Motor with Two Supplies

Part Number	Circuit Count	V _{CE0} (V)/ V _{DSS} (V)	I _c (A)/ I _D (A)	h _{FE} (min)	R _{Ds(ON)} max (Ω)	Equivalent Circuit	Package
SMA6511	5	100±15/-60	1.5/-3	2000		16	SIP12 (SMA12Pin)

●For 5-Phase Motor Drive

Part Number	Circuit Count	V _{CE0} (V)/ V _{DSS} (V)	I _c (A)/ I _D (A)	h _{FE} (min)	R _{Ds(ON)} max (Ω)	Equivalent Circuit	Package
SLA5074	4	60	5		0.3	17	SIP15 with Fin (SLA15Pin)
SLA5065	4	60	7		0.1	17	SIP15 with Fin (SLA15Pin)
SLA5073	6	60	5		0.3	13	SIP15 with Fin (SLA15Pin)
SLA5068	6	60	7		0.1	13	SIP15 with Fin (SLA15Pin)

●Equivalent Circuit (for Motor Driver)

④

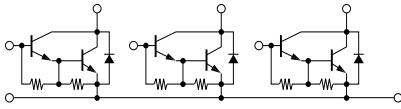

⑤

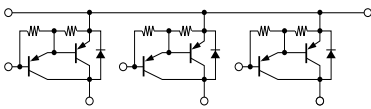

⑥

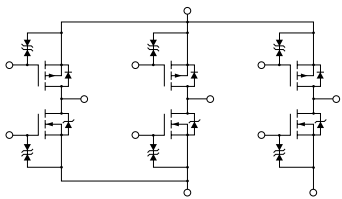

⑦

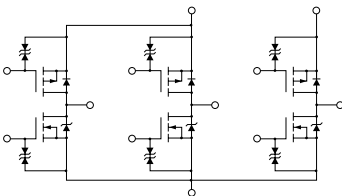

⑧

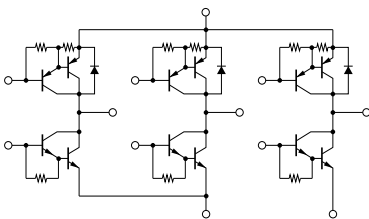

⑨

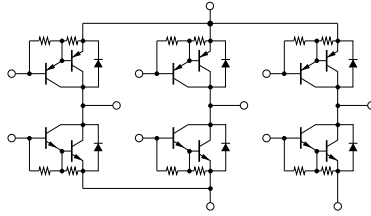

⑩

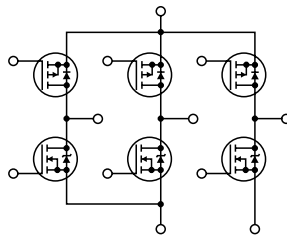

⑪



⑫

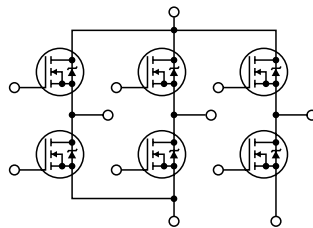

⑬

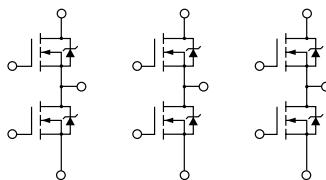

⑭

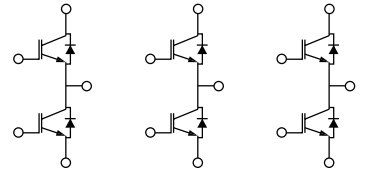

⑮

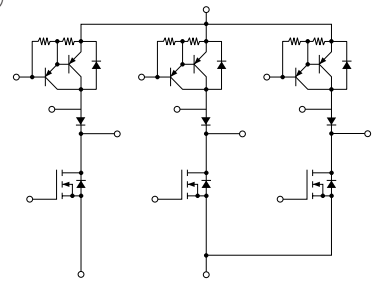

⑯

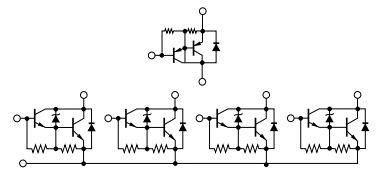

⑰

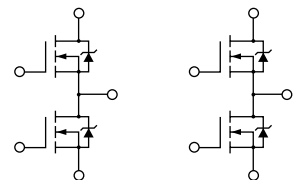

Specifications List by Application Partial switching PFC Arrays

●For Partial switching PFC

Part Number	Circuit Count	V _{CE(s)} (V)	I _c (A)	V _{CE(sat)} (V)	Equivalent Circuit	Package
SLA5222	1+Di X 4	600	30	1.3typ	1	SIP12 with Fin (SLA12Pin)
SLA5227	1+Di X 4	600	30	1.3typ	2	SIP12 with Fin (SLA12Pin)

●Equivalent Circuit (for Partial switching PFC)

①



②



Part Number List by Application

Applications	Typical Connection Diagram	Part Number		
		Transistors		MOS FETs
		Darlington	Single	
<ul style="list-style-type: none"> ● Solenoid ● Relay 		STA301A STA401A STA406A STA471A STA475A STA481A STA485A	STA460C STA413A	
		SLA4031 SLA4041 SLA4060 SMA4032 SMA4033 SMA4036		SMA5106
		SLA4071 SMA4021		
		STA302A STA402A STA408A STA472A SLA4070 SMA4020	STA322A STA421A	

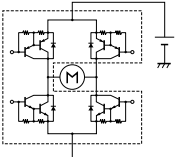
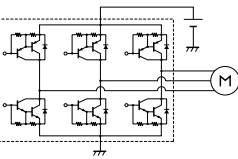
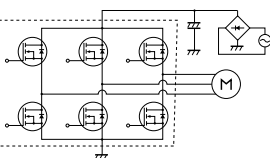
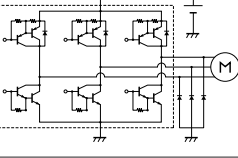
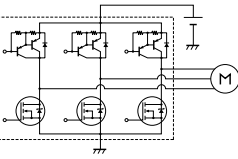
Applications		Typical Connection Diagram	Part Number									
			Transistors		MOS FETs							
			Darlington	Single								
●DC Motor	Normal/Reverse Rotation Control		STA434A STA457C SLA4390	STA431A STA474A								
●3-Phase DC Brushless Motor	AC100V Direct Driver		STA302A+STA303A SMA6010 SLA6020 SMA6080									
						AC200V Direct Driver				SLA5075 SMA5112 SMA5117 SMA5118 SMA5131 SMA5132 SMA5133		
	PWM Control		SLA6012 SLA6022 SLA6023 SLA6024 SLA6026									
											SMA5130	

Applications		Typical Connection Diagram	Part Number		
			Transistors		MOS FETs
			Darlington	Single	
●Stepping Motor	Constant Voltage Driver		STA401A STA406A STA435A STA471A STA475A STA481A STA485A SLA4010	STA460C STA413A	
	Two Supplies Driver		SMA6511		
	Bipolar Driver		STA473A STA472A STA408A STA404A STA403A STA402A SMA4030 SMA4020 SLA4070 SLA4060 SLA4030	STA421A STA412A	

Applications	Typical Connection Diagram	Part Number	
		N-CH	P-CH
●5-Phase Motor		SLA5065+SLA5068 SLA5073+SLA5074 SLA5085	SLA5086

• SIP 8 (STA8Pin)



• SIP 10 (STA10Pin)

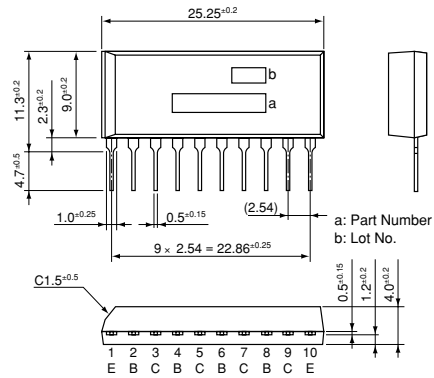

• SIP 12 (SMA12Pin)

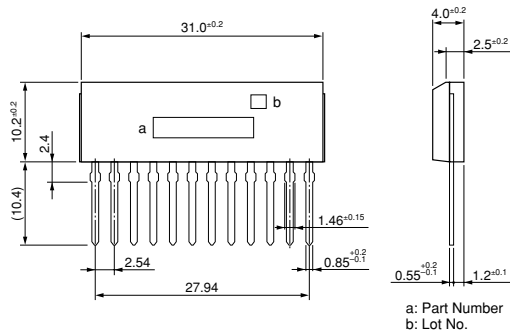

• SIP 15 (SMA15Pin)

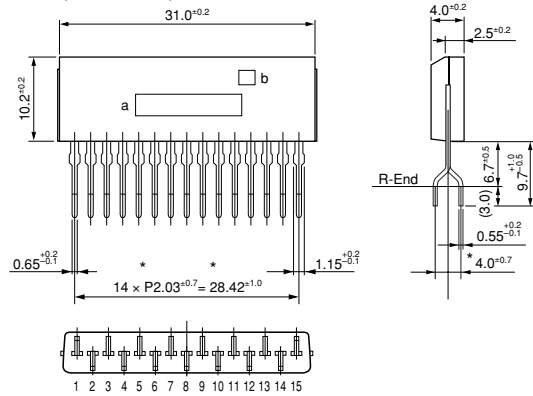

• SIP 12 with Fin (SLA12Pin)



• SIP 15 with Fin (SLA15Pin)

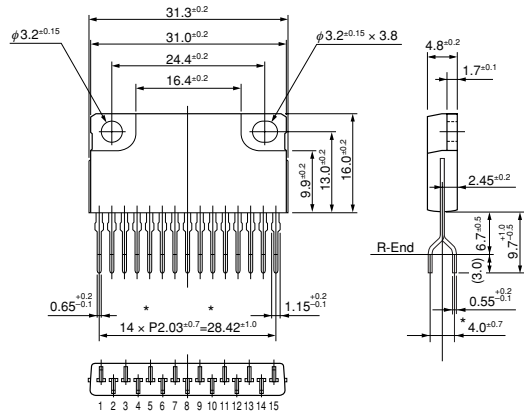

• SIP 15 with Fin (SLA15Pin)



(Unit:mm)

Thyristors

Ordering Information & Standard Packing Quantities	192
Application Note	193
3-1 Thyristors	194
3-2 Triacs	196
Package Type (Dimensions).....	198

Ordering Information

All products listed must be ordered in standard packing increments.

Product Name	Package	Standard Packing Quantities (Bulk)
TFC563D	TO220S(Straight)	600(Stick)
TF541S-A	TO220F	1000(Box)/3750(Stick)
TF561S-A	TO220F	1000(Box)/3750(Stick)
TFA37S	TO220F	1000(Box)/3750(Stick)
TFA38S	TO220F	1000(Box)/3750(Stick)
TFA57S	TO220F	1000(Box)/3750(Stick)
TFA58S	TO220F	1000(Box)/3750(Stick)
TFA87S	TO220F	1000(Box)/3750(Stick)
TFA88S	TO220F	1000(Box)/3750(Stick)
TFA107S	TO220F	1000(Box)/3750(Stick)
TFA108S	TO220F	1000(Box)/3750(Stick)
TMA104S-L	TO220F	1000(Box)/3750(Stick)
TMA106G-L	TO220	4000(Stick)
TMA106H-L	TO220F-A	4000(Stick)
TMA106S-L	TO220F	1000(Box)/3750(Stick)
TMA124S-L	TO220F	1000(Box)/3750(Stick)
TMA126G-L	TO220	4000(Stick)
TMA126H-L	TO220F-A	4000(Stick)
TMA126S-L	TO220F	1000(Box)/3750(Stick)
TMA164B-L	TO3PF	500(Box)/1080(Stick)
TMA164P-L	TO3P	500(Box)/1080(Stick)
TMA164S-L	TO220F	1000(Box)/3750(Stick)
TMA166B-L	TO3PF	500(Box)/1080(Stick)
TMA166G-L	TO220	4000(Stick)
TMA166H-L	TO220F-A	4000(Stick)
TMA166P-L	TO3P	500(Box)/1080(Stick)
TMA166S-L	TO220F	1000(Box)/3750(Stick)
TMA204S-L	TO220F	1000(Box)/3750(Stick)
TMA206S-L	TO220F	1000(Box)/3750(Stick)
TMA254B-L	TO3PF	500(Box)/1080(Stick)
TMA256B-L	TO3PF	500(Box)/1080(Stick)
TMA34S-L	TO220F	1000(Box)/3750(Stick)
TMA36G-L	TO220	4000(Stick)
TMA36H-L	TO220F-A	4000(Stick)
TMA36S-L	TO220F	1000(Box)/3750(Stick)
TMA54S-L	TO220F	1000(Box)/3750(Stick)
TMA56G-L	TO220	4000(Stick)
TMA56H-L	TO220F-A	4000(Stick)
TMA56S-L	TO220F	1000(Box)/3750(Stick)
TMA84S-L	TO220F	1000(Box)/3750(Stick)
TMA86G-L	TO220	4000(Stick)
TMA86H-L	TO220F-A	4000(Stick)
TMA86S-L	TO220F	1000(Box)/3750(Stick)
TMB166S-L	TO220F	1000(Box)/3750(Stick)
TMB206S-L	TO220F	1000(Box)/3750(Stick)

Application Note

Since reliability can be affected adversely by improper storage environment or handling methods during Characteristic tests, please observe the following cautions.

■ Cautions for Storage

- Ensure that storage conditions comply with the normal temperature (5 to 35°C) and the normal relative humidity (around 40 to 75%), and avoid storage locations that experience high temperature and humidity, or extreme changes in temperature or humidity.
- Avoid locations where dust or harmful gases are present, and avoid direct sunlight.
- Reinspect the devices for rust in leads and solderability after stored for a long time.

■ Cautions for Characteristic Tests and Handling

On characteristics test at incoming inspection, etc, take good care to avoid the surge voltages from the test equipment, the short circuit at terminals, or the wrong connection.

■ Silicone Grease

When using a heatsink, please coat thinly and evenly the back surface of the device and both surfaces of the insulating plate with silicone grease to lower the thermal resistance between the device and the heatsink.

Please select proper silicone grease carefully since the oil in some grease products may penetrate the device and result in an extremely short device life.

Recommended Silicone Grease

- G-746 (Shin-Etsu Chemical)
- YG6260 (Momentive Performance Materials Inc.)
- SC102 (Dow Corning Toray Silicone)

■ Mounting Torque

When mounting torque is insufficient, thermal resistance increases, and so heat radiation effect is decreased. When the torque is excessive, the screw may be broken, the heatsink may be deformed, and the device frame may be distorted, resulting in the device damage. Recommended mounting torque per package is as follows:

● Mounting Torque Table

Package	Screw Torque
TO220	0.490 to 0.686 N•m (5 to 7kgf•cm)
TO220F-A, TO220F (FM20)	
TO3P (MT100)	
TO3PF (FM100)	0.686 to 0.882 N•m (7 to 9kgf•cm)

- * When the surface of a heatsink where Full Mold package is to be mounted is not flat due to the burred metal bracket for screwing around the mounting hole of the heatsink, the resin of the package might be cracked even if the torque is lower than the recommended value.
- * When a screw is fastened with an air driver for the Full Mold package, a large impact is generated at the time of stop, and the resin may crack even if the torque is lower than the recommended value. An electric driver, therefore, should be used instead of an air driver.

■ Heatsink

A larger contact area between the device and the heatsink is required for more effective heat radiation. To ensure a larger contact area, minimize mounting holes. And select a heatsink with a surface smooth enough and free from burrs and slivers.

■ Soldering Temperature

In general, the device mounted on a printed circuit board is subjected to high temperatures from flow solder in a solder bath, or, from a soldering iron at hand soldering.

The testing method and test conditions for a device's heat resistance to soldering are:

At a distance of 1.5mm from the device's main body, apply 260°C for 10 seconds, and 350°C for 3 seconds.

Please observe these limits and finish soldering in as short a time as possible.

Since reliability can be affected adversely by improper storage environment or handling methods during Characteristic tests, please observe the following cautions.

3-1 Thyristors

Thyristors

Part Number	Absolute Maximum Ratings												I _{RRM} I _{DRM} (mA) max	Conditions T _j (°C)
	V _{RSM} V _{DSM} (V)	V _{RRM} V _{DRM} (V)	I _T (AV) (A)	Conditions T _c (°C)	I _T (RMS) (50Hz) (A)	I _{TSM} 50Hz Single Half Sine Wave, Default T _j =125°C (A)	P _{GM} (W)	P _G (AV) (W)	V _{RGM} (V)	I _{FGM} (A)	T _j (°C)	T _{stg} (°C)		
TF541S-A	500	400	5.0	88	7.8	80	5.0	0.5	5.0	2.0	-40 to +125	2.0	125	
TF561S-A	700	600	5.0	88	7.8	80	5.0	0.5	5.0	2.0	-40 to +125	2.0	125	
TFA37S	-	700	3.0	127	4.7	60	5.0	0.5	5.0	2.0	-40 to +150	2.0	150	
TFA57S	-	700	5.0	115	7.8	80	5.0	0.5	5.0	2.0	-40 to +150	2.0	150	
TFA87S	-	700	8.0	98	12.6	120	5.0	0.5	5.0	2.0	-40 to +150	2.0	150	
TFA107S	-	700	10	86	15.7	160	5.0	0.5	5.0	2.0	-40 to +150	2.0	150	
TFA38S	-	800	3.0	50	4.7	60	5.0	0.5	5.0	2.0	-40 to +150	2.0	150	
TFA58S	-	800	5.0	50	7.8	80	5.0	0.5	5.0	2.0	-40 to +150	2.0	150	
TFA88S	-	800	8.0	50	12.6	120	5.0	0.5	5.0	2.0	-40 to +150	2.0	150	
TFA108S	-	800	10	50	15.7	160	5.0	0.5	5.0	2.0	-40 to +150	2.0	150	

3-Pin Reverse Conducting Thyristors for HID Lamp Ignition

Part Number	Absolute Maximum Ratings										I _{DRM} (mA) max	Conditions T _j (°C)	V _{TM} (V) max	Conditions	
	V _{DRM} (V)	I _{TRM} *1 (A)	di/dt*1 (A/μs)	P _{GM} (W)	P _G (AV) (W)	V _{RGM} (V)	I _{FGM} *2 (A)	I _{FRM} (A)	T _j (°C)	T _{stg} (°C)				T _c (°C)	I _{TM} (A)
TFC563D	600	500	1500	5.0	0.5	5.0	2.0	450	-40 to +125	1.0	125	1.4	25	10	

*1: T_c≤100°C, V_D≤430V, W_p≤1.0μs, I_G≥70mA, dig/dt≥0.5A/μs, 100kcycles

*2: T_c≤100°C, V_D≤430V, W_p≤1.0μs, 100kcycles

Electrical Characteristics																	Package	Mass g
V _{TM} (V) max	Conditions T _c (°C) I _{TM} (A)		V _{GT} (V)		I _{GT} (mA)		Conditions T _c (°C)	V _{GD} (V) min	T _j (°C)	Conditions V _D (V)	dv/dt (V/μs) typ	Conditions T _j (°C)	V _D (V)	I _H (mA) typ	R _{th} (°C/W) max			
		typ	max	typ	max	typ	max											
1.4	25	10		1.5	0.03	0.2	25	0.1	125	1/2V _{DRM}	20	125	1/2V _{DRM}	4.0	4.0	TO220F	2.0	
1.4	25	10		1.5	0.03	0.2	25	0.1	125	1/2V _{DRM}	20	125	1/2V _{DRM}	4.0	4.0	TO220F	2.0	
1.5	25	10	—	1.0	7.0	15	25	0.2	125	1/2V _{DRM}	300	125	1/2V _{DRM}	15	4.1	TO220F	2.0	
1.5	25	15	—	1.0	7.0	15	25	0.2	125	1/2V _{DRM}	300	125	1/2V _{DRM}	15	3.8	TO220F	2.0	
1.4	25	20	—	1.0	7.0	15	25	0.2	125	1/2V _{DRM}	300	125	1/2V _{DRM}	20	3.5	TO220F	2.0	
1.35	25	20	—	1.0	7.0	15	25	0.2	125	1/2V _{DRM}	300	125	1/2V _{DRM}	20	3.4	TO220F	2.0	
1.5	25	10	—	1.0	—	15	25	0.2	125	1/2V _{DRM}	300	125	1/2V _{DRM}	15	4.1	TO220F	2.0	
1.5	25	15	—	1.0	—	15	25	0.2	125	1/2V _{DRM}	300	125	1/2V _{DRM}	15	3.8	TO220F	2.0	
1.5	25	20	—	1.0	—	15	25	0.2	125	1/2V _{DRM}	300	125	1/2V _{DRM}	20	3.5	TO220F	2.0	
1.35	25	20	—	1.0	—	15	25	0.2	125	1/2V _{DRM}	300	125	1/2V _{DRM}	20	3.4	TO220F	2.0	

Electrical Characteristics												Package	Mass (g)
V _{GT} (V)		I _{GT} (mA)		Conditions T _c (°C)	V _{GD} (V) min	Conditions T _j (°C) V _D (V)		I _H (mA) typ	R _{th} (°C/W) max	V _F (V) max	Conditions IF (A)		
typ	max	typ	max										
	1.5		30	25	0.1	125	480	12	4.0	1.4	10	TO-220S	1.5

3-2 Triacs

Triacs

Part Number	Absolute Maximum Ratings										IDRM1		IDRM2		V _{TM}	
	V _{DRM}	I _{T (RMS)}	Conditions T _c (°C)	I _{TSM}	Conditions	P _{GM}	P _{G (AV)}	I _{GM}	T _J	T _{stg}	(mA) max	Conditions	(mA) max	Conditions	V _{TM} (V) max	Conditions I _{TM} (A)
	(V)	(A)		(A)		(W)	(W)	(A)	(°C)	(°C)						
TMA34S-L	400	3	109	30	125	3	0.3	0.5	-40 to +125		0.1		2		1.5	4.5
TMA54S-L	400	5	102	50	125	5	0.5	2	-40 to +125		0.1		2		1.5	7
TMA84S-L	400	8	92	80	125	5	0.5	2	-40 to +125		0.1		2		1.5	12
TMA104S-L	400	10	85	100	125	5	0.5	2	-40 to +125		0.1		2		1.5	14
TMA124S-L	400	12	77	120	125	5	0.5	2	-40 to +125		0.1		2		1.5	17
TMA164S-L	400	16	66	160	125	5	0.5	2	-40 to +125		0.1		2		1.45	20
TMA164P-L	400	16	108	160	125	5	0.5	2	-40 to +125		0.1		2		1.4	20
TMA164B-L	400	16	98	160	125	5	0.5	2	-40 to +125		0.1		2		1.4	20
TMA204S-L	400	20	53	190	125	5	0.5	2	-40 to +125		0.1		2		1.4	20
TMA254B-L	400	25	83	250	125	5	0.5	2	-40 to +125		0.1		2		1.3	20
TMA36S-L	600	3	109	30	125	3	0.3	0.5	-40 to +125		0.1		2		1.5	4.5
TMA36G-L	600	3	115	30	25	3	0.5	0.5	-40 to +125		0.1		2		1.5	4.5
TMA36H-L	600	3	109	30	25	3	0.5	0.5	-40 to +125		0.1		2		1.5	4.5
TMA56S-L	600	5	102	50	125	5	0.5	2	-40 to +125		0.1		2		1.5	7
TMA56G-L	600	5	111	50	25	5	0.5	2	-40 to +125		0.1		2		1.5	7
TMA56H-L	600	5	101	50	25	5	0.5	2	-40 to +125		0.1		2		1.5	7
TMA86S-L	600	8	92	80	125	5	0.5	2	-40 to +125		0.1	25°C	2	125°C	1.5	12
TMA86G-L	600	8	107	80	25	5	0.5	2	-40 to +125		0.1		2		1.5	12
TMA86H-L	600	8	91	80	25	5	0.5	2	-40 to +125		0.1		2		1.5	12
TMA106S-L	600	10	85	100	125	5	0.5	2	-40 to +125		0.1		2		1.5	14
TMA106G-L	600	10	105	100	25	5	0.5	2	-40 to +125		0.1		2		1.5	14
TMA106H-L	600	10	83	100	25	5	0.5	2	-40 to +125		0.1		2		1.5	14
TMA126S-L	600	12	77	120	125	5	0.5	2	-40 to +125		0.1		2		1.5	17
TMA126G-L	600	12	103	120	25	5	0.5	2	-40 to +125		0.1		2		1.5	17
TMA126H-L	600	12	78	120	25	5	0.5	2	-40 to +125		0.1		2		1.5	17
TMA166S-L	600	16	66	160	125	5	0.5	2	-40 to +125		0.1		2		1.45	20
TMA166G-L	600	16	100	160	25	5	0.5	2	-40 to +125		0.1		2		1.45	20
TMA166H-L	600	16	65	160	25	5	0.5	2	-40 to +125		0.1		2		1.45	20
TMA166P-L	600	16	108	160	125	5	0.5	2	-40 to +125		0.1		2		1.4	20
TMA166B-L	600	16	98	160	125	5	0.5	2	-40 to +125		0.1		2		1.4	20
TMB166S-L	600	16	94	160	125	5	0.5	2	-40 to +150		0.1		2		1.45	20
TMA206S-L	600	20	53	190	125	5	0.5	2	-40 to +125		0.1		2		1.4	20
TMB206S-L	600	20	85	200	125	5	0.5	2	-40 to +150		0.1		2		1.4	20
TMA256B-L	600	25	83	250	125	5	0.5	2	-40 to +125		0.1		2		1.3	20

Electrical Characteristics (T_j = 25°C, unless otherwise specified)

	V _{GT}			Conditions		I _{GT}			Conditions		V _{GD}		(dv/dt) _c		R _{th(j-c)} (°C/W) max	Package	Mass (g)		
	Mode I (T2+, G+) (V) max	Mode II (T2+, G-) (V) max	Mode III (T2-, G-) (V) max	V _D (V)	R _L (Ω)	Mode I (T2+, G+) (mA) max	Mode II (T2+, G-) (mA) max	Mode III (T2-, G-) (mA) max	V _D (V)	R _L (Ω)	T _j (°C)	V _O (V)	(V/us) min	Conditions (dv/dt) _c (-A/ms)				T _j (°C)	
	1.5	1.5	1.5	12	20	20	20	20	12	20	0.2	125	1/2V _{DRM}	5	1.5	125	4.5	TO220F	2.0
	1.5	1.5	1.5	12	20	20	20	20	12	20	0.2	125	1/2V _{DRM}	5	2.5	125	4	TO220F	2.0
	1.5	1.5	1.5	12	20	30	30	30	12	20	0.2	125	1/2V _{DRM}	10	4	125	3.7	TO220F	2.0
	1.5	1.5	1.5	12	20	30	30	30	12	20	0.2	125	1/2V _{DRM}	10	5	125	3.6	TO220F	2.0
	1.5	1.5	1.5	12	20	30	30	30	12	20	0.1	125	1/2V _{DRM}	10	6	125	3.5	TO220F	2.0
	1.5	1.5	1.5	12	20	30	30	30	12	20	0.2	125	1/2V _{DRM}	10	8	125	3.3	TO220F	2.0
	1.5	1.5	1.5	12	20	30	30	30	12	20	0.2	125	1/2V _{DRM}	10	8	125	1.2	TO3P	6.0
	1.5	1.5	1.5	12	20	30	30	30	12	20	0.2	125	1/2V _{DRM}	10	8	125	1.8	TO3PF	6.5
	1.5	1.5	1.5	12	20	30	30	30	12	20	0.2	125	1/2V _{DRM}	10	10	125	3.2	TO220F	2.0
	1.5	1.5	1.5	12	20	30	30	30	12	20	0.2	125	1/2V _{DRM}	10	12	125	1.6	TO3PF	6.5
	1.5	1.5	1.5	12	20	15/20	15/20	15/20	12	20	0.2	125	1/2V _{DRM}	5	1.5	125	4.5	TO220F	2.0
	1.5	1.5	1.5	12	20	30	30	30	12	20	0.2	125	1/2V _{DRM}	5	1.5	125	3	TO220	2.5
	1.5	1.5	1.5	12	20	30	30	30	12	20	0.2	125	1/2V _{DRM}	5	1.5	125	4.6	TO220F-A	2.0
	1.5	1.5	1.5	12	20	15/20	15/20	15/20	12	20	0.2	125	1/2V _{DRM}	5	2.5	125	4	TO220F	2.0
	1.5	1.5	1.5	12	20	30	30	30	12	20	0.2	125	1/2V _{DRM}	5	2.5	125	2.5	TO220	2.5
	1.5	1.5	1.5	12	20	30	30	30	12	20	0.2	125	1/2V _{DRM}	5	2.5	125	4.2	TO220F-A	2.0
	1.5	1.5	1.5	12	20	20/30	20/30	20/30	12	20	0.2	125	1/2V _{DRM}	10	4	125	3.7	TO220F	2.0
	1.5	1.5	1.5	12	20	30	30	30	12	20	0.2	125	1/2V _{DRM}	10	4	125	2	TO220	2.5
	1.5	1.5	1.5	12	20	30	30	30	12	20	0.2	125	1/2V _{DRM}	10	4	125	3.8	TO220F-A	2.0
	1.5	1.5	1.5	12	20	20/30	20/30	20/30	12	20	0.2	125	1/2V _{DRM}	10	5	125	3.6	TO220F	2.0
	1.5	1.5	1.5	12	20	30	30	30	12	20	0.2	125	1/2V _{DRM}	10	5	125	1.8	TO220	2.5
	1.5	1.5	1.5	12	20	30	30	30	12	20	0.2	125	1/2V _{DRM}	10	5	125	3.7	TO220F-A	2.0
	1.5	1.5	1.5	12	20	20/30	20/30	20/30	12	20	0.2	125	1/2V _{DRM}	10	6	125	3.5	TO220F	2.0
	1.5	1.5	1.5	12	20	30	30	30	12	20	0.2	125	1/2V _{DRM}	10	6	125	1.6	TO220	2.5
	1.5	1.5	1.5	12	20	30	30	30	12	20	0.2	125	1/2V _{DRM}	10	6	125	3.5	TO220F-A	2.0
	1.5	1.5	1.5	12	20	20/30	20/30	20/30	12	20	0.2	125	1/2V _{DRM}	10	8	125	3.3	TO220F	2.0
	1.5	1.5	1.5	12	20	30	30	30	12	20	0.2	125	1/2V _{DRM}	10	8	125	1.4	TO220	2.5
	1.5	1.5	1.5	12	20	30	30	30	12	20	0.2	125	1/2V _{DRM}	10	8	125	3.3	TO220F-A	2.0
	1.5	1.5	1.5	12	20	30	30	30	12	20	0.2	125	1/2V _{DRM}	10	8	125	1.2	TO3P	6.0
	1.5	1.5	1.5	12	20	30	30	30	12	20	0.2	125	1/2V _{DRM}	10	8	125	1.8	TO3PF	6.5
	1.5	1.5	1.5	12	20	30	30	30	12	20	0.2	125	1/2V _{DRM}	10	10	125	3.0	TO220F	2.0
	1.5	1.5	1.5	12	20	20/30	20/30	20/30	12	20	0.2	125	1/2V _{DRM}	10	10	125	3.2	TO220F	2.0
	1.5	1.5	1.5	12	20	30	30	30	12	20	0.2	125	1/2V _{DRM}	10	10	125	2.7	TO220F	2.0
	1.5	1.5	1.5	12	20	30	30	30	12	20	0.2	125	1/2V _{DRM}	10	12	125	1.6	TO3PF	6.5

Package Type (Dimensions)

• TO-220

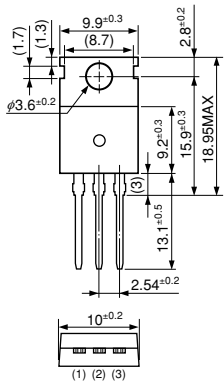

• TO-220F-A

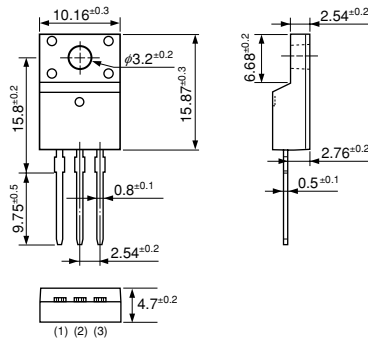

• TO-220F

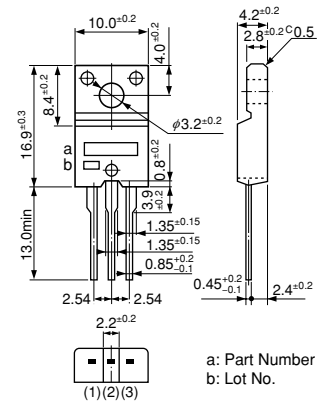

Pin No.	
(1)	Cathode (T ₁)
(2)	Anode (T ₂)
(3)	Gate (G)
()	Triacs

• TO-3P

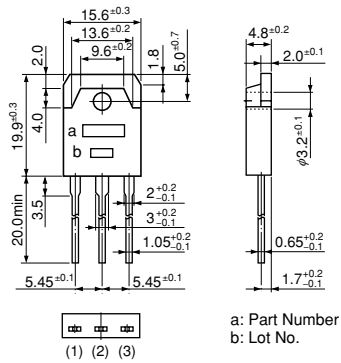

• TO-3PF

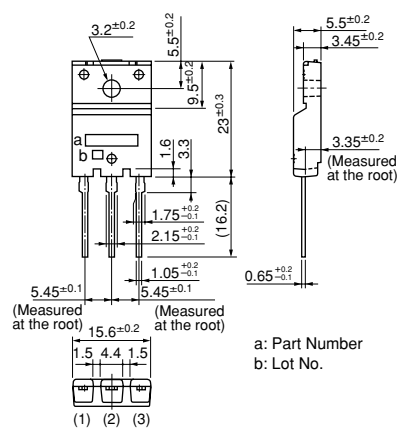

• TO-220S Straight

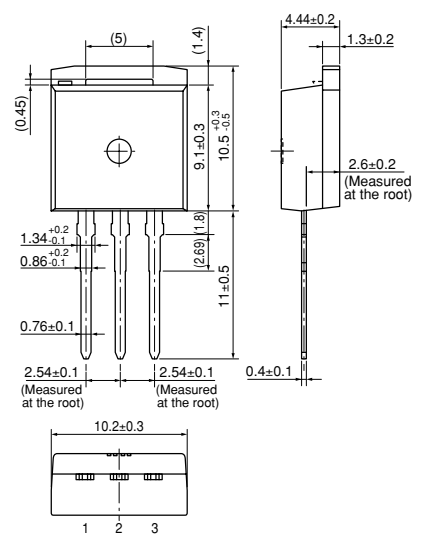

(Unit: mm)

Diodes

Ordering Information & Standard Packing Quantities	200
Taping Specifications	202
Application Note	205
Marking Guide	206
4-1 Rectifier Diodes	207
Surface-Mount	207
Thru-Hole	207
4-2 Fast Recovery Diodes	208
Thru-Hole	208
4-3 Ultrafast Recovery Diodes	210
Surface-Mount	210
Thru-Hole	210
4-4 Schottky Barrier Diodes	213
Standard	213
• Surface-Mount	213
• Thru-Hole	213
Low VF "A Series"	214
• Surface-Mount	214
• Thru-Hole	214
Low IR "E Series"	215
• Surface-Mount	215
• Thru-Hole	215
Low VF/Low IR Balance "J Series"	215
• Surface-Mount	215
• Thru-Hole	215
4-5 Power Zener Diodes	216
4-6 Silicon Varistors	217
Package Type (Dimensions)	218

Series Name/Product Name	Package	Standard Packing Quantities			
		Bulk	Taping		
SJPA-xx	SJP	–	V:1800(Reel)		
SJPB-xx	SJP	–	V:1800(Reel)		
SJPE-xx	SJP	–	V:1800(Reel)		
SJPJ-xx	SJP	–	V:1800(Reel)		
SJPL-xx	SJP	–	V:1800(Reel)		
SJPM-xx	SJP	–	V:1800(Reel)		
SJPW-xx	SJP	–	V:1800(Reel)		
SJPX-xx	SJP	–	V:1800(Reel)		
SJPZ-xx	SJP	–	V:1800(Reel)		
SZ-10xx	SZ-10(Surface-mount)	–	VL:750(Reel)	VR:750(Reel)	
FMC-2xU	TO220F(2-element)	500	–		
FM2-2202	TO220F(Center-tap)	500	–		
FMB-2x	TO220F(Center-tap)	500	–		
FMEN-2x	TO220F(Center-tap)	500	–		
FMG-1x	TO220F(Center-tap)	500	–		
FMG-2x	TO220F(Center-tap)	500	–		
FMJ-2x	TO220F(Center-tap)	500	–		
FML-1x	TO220F(Center-tap)	500	–		
FML-2x	TO220F(Center-tap)	500	–		
FMM-2x	TO220F(Center-tap)	500	–		
FMU-1x	TO220F(Center-tap)	500	–		
FMU-2x	TO220F(Center-tap)	500	–		
FMW-2x	TO220F(Center-tap)	500	–		
FMX-1x	TO220F(Center-tap)	500	–		
FMX-2x	TO220F(Center-tap)	500	–		
FMXA-2x	TO220F(Center-tap)	500	–		
FMB-G1x	TO220F-2Pin	500	–		
FMB-G2x	TO220F-2Pin	500	–		
FMC-G2x	TO220F-2Pin	500	–		
FMD-G2x	TO220F-2Pin	500	–		
FMG-G2x	TO220F-2Pin	500	–		
FML-G1x	TO220F-2Pin	500	–		
FML-G2x	TO220F-2Pin	500	–		
FMN-G1x	TO220F-2Pin	500	–		
FMN-1x	TO220F-2Pin	500	–		
FMU-G1x	TO220F-2Pin	500	–		
FMU-G2x	TO220F-2Pin	500	–		
FMXA-1x	TO220F-2Pin	500	–		
FMX-G1x	TO220F-2Pin	500	–		
FMX-G2x	TO220F-2Pin	500	–		
FMC-2xUA	TO220F-2Pin(2-element)	500	–		
MPE-2x	TO220S(Surface-mount)	–	VR:1000(Reel)		
MPL-102S	TO220S(Surface-mount)	–	VR:1000(Reel)		
MPEN-2x	TO263(Surface-mount)	–	VL:800(Reel)	VR:800(Reel)	
MPL-1036S	TO220S(Surface-mount)	–	VL:800(Reel)	VR:800(Reel)	
FMD-4x	TO3PF(Center-tap)	500	–		
FMXA-4x	TO3PF(Center-tap)	500	–		
FML-4x	TO3PF(Center-tap)	500	–		
FMW-4x	TO3PF(Center-tap)	500	–		
FMN-3x	TO3PF-2Pin	500	–		

Taping Specifications

Taping Name	Taping Type, Dimensions (mm)	Packing Dimensions (mm) and Packing Note	Quantity
<p>V</p> <p>To specify the taping type, add a suffix [V]</p>	<p>Axial taping</p> 	<p>Reel</p> 	<p>5,000 pcs/reel (2.7φ body) 3,000 pcs/reel (4φ body)</p>
<p>V1</p> <p>To specify the taping type, add a suffix [V1]</p>	<p>Axial taping</p> 	<p>Ammunition (Ammo) pack</p> 	<p>2,000 pcs/box (2.7φ body) 3,000 pcs/box (2.4φ body) 1,000 pcs/box (4φ body)</p>
<p>V0</p> <p>To specify the taping type, add a suffix [V0]</p>	<p>Axial taping</p> 	<p>Ammunition (Ammo) pack</p> 	<p>2,000 pcs/box (2.7φ body) 3,000 pcs/box (2.4φ body)</p>

Taping Name	Taping Type, Dimensions (mm)	Packing Dimensions (mm) and Packing Note	Quantity
<p>W</p> <p>To specify the taping type, add a suffix [W]</p>	<p>Radial taping</p>	<p>Ammunition (Ammo) pack</p>	<p>4,000 pcs/box (2.7φ body) (0.6φ lead only)</p>
<p>WS</p> <p>To specify the taping type, add a suffix [WS]</p>	<p>Radial taping (for A0 series)</p>	<p>Ammunition (Ammo) pack</p>	<p>2,500 pcs/box (2.4φ body)</p>
<p>WK</p> <p>To specify the taping type, add a suffix [WK]</p>	<p>Radial taping (for A0 series)</p>		<p>2,500 pcs/box (2.4φ body)</p>

Surface-Mount Taping Specifications

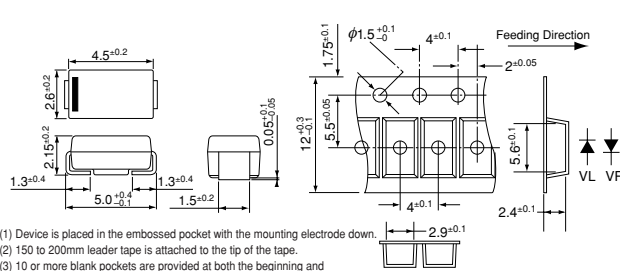
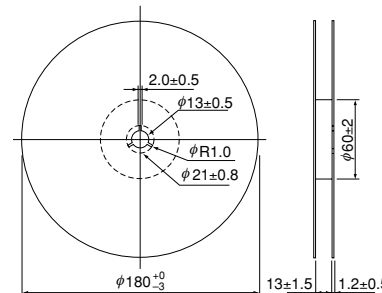
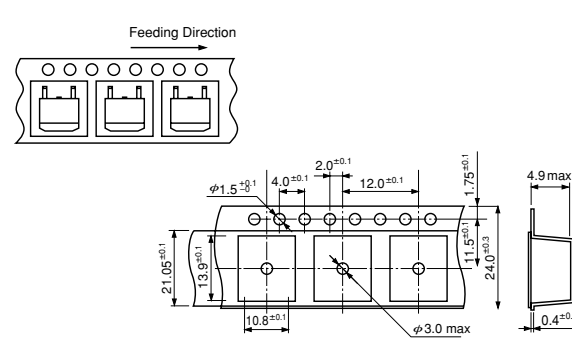
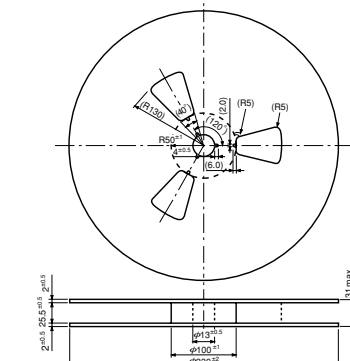
Taping Name	Taping Type, Dimensions (mm)	Packing Dimensions (mm) and Packing Note	Quantity
SJP VL VR	Emboss Taping  <p>(1) Device is placed in the embossed pocket with the mounting electrode down. (2) 150 to 200mm leader tape is attached to the tip of the tape. (3) 10 or more blank pockets are provided at both the beginning and the end of the tape.</p>	Reel 	1800 pcs/reel
TO-220 VR			1000 pcs/reel

Power Zener Surface-Mount Taping Specifications

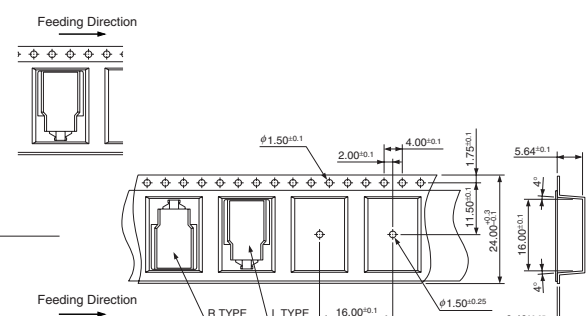
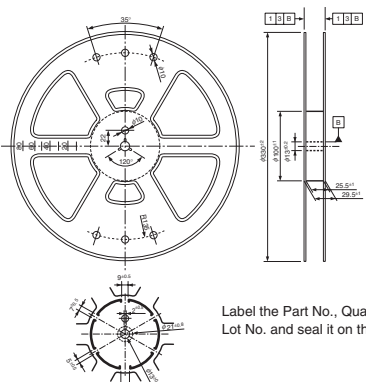
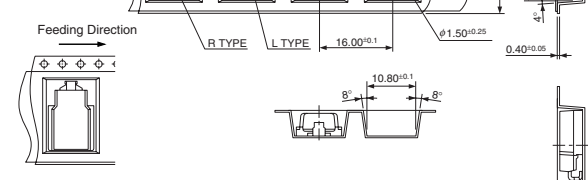
Taping Name	Taping Type, Dimensions (mm)	Packing Dimensions (mm) and Packing Note	Quantity
VL		 <p>Label the Part No., Quantity, Lot No. and seal it on the reel</p>	750 pcs/reel
VR			750 pcs/reel

Application Note

General Description

(1) Lead Forming

When forming leads, hold the lead wire on the main body's side so as to prevent stress from being applied to the main body.



(2) Mounting

To mount a frame-type diode on a heatsink, use its screw hole. Do not fix its resin body as the silicon chip may get broken.

(3) Temperature Measurement

For an axial type diode, measure the temperature of the lead wire on the main body side. The thermocouple to be used must be as thin as possible (approximately $\phi 0.125\text{mm}$).

(4) Temperature Rise Consideration

A diode's temperature increases due to losses from forward current, reverse current and reverse recovery time. In normal use, losses are mainly attributable to forward current and voltage. However, in high frequency circuits such as switching power supplies, losses due to reverse recovery time also occurs. Moreover, in diodes having large reverse currents like Schottky barrier diode losses due to reverse current cannot be disregarded. Forward loss tends to decrease at high temperatures. However, reverse loss tends to increase at high temperatures. Therefore, it is necessary to consider the ambient temperature when verifying operation.

(5) Inrush Current

In a capacitor-input type rectifier circuit, inrush current flows when the power supply is switched on. The peak value of this inrush current shall be set less than peak forward surge current I_{FSM} (I^2t can also be obtained but set the minimum pulse width to 1 msec). The value of I_{FSM} is guaranteed for a single shot only. If the inrush current is repeated within a short period of time, the derating has to be taken into account.

(6) Peak Value Current

Considering normal use, limit of the peak value current must be set to 10 times of the average current I_F (AV). If the peak value increases, the diode's forward loss also increases. In this case, check the temperature rise.

- Carefully study the mounting method when the usage environment is prone to creeping discharge.

Surface-Mount Diodes

(Part Number Type: SJP)

Soldering (common to flow and reflow)

- Use rosin based flux. Never use acidic fluxes.
- To prevent a large thermal stress, preheat within 1 to 2 minutes at 150°C and solder within the usable range shown below.



- For using a soldering iron, use the following references:
Temperature of soldering iron tip:

Lower than 300°C
(Power of the soldering iron: 30W or lower)
The soldering tip must be as thin as possible.

Soldering time: Less than 10 seconds

Reference SJP Series Copper Laminate Pattern

(Unit : mm)

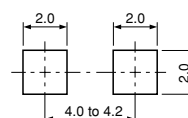

Marking Guide

1 Axial (A0)



- ① Part Number (abbreviation)
The AM01 is indicated as "M."
- ② Class
Z: 200V None: 400V A: 600V
B: 800V C: 1000V
- ③ Manufacturing date
First letter: Year (Last digit of year)
Second letter: Month (1 to 9, O, N, D)
- ④ Cathode band: Continuous band
Color of the band: White (Yellow for AU02 series)

2 Axial (E0, E1)



- ① Part Number (abbreviation)
EM01, EM2, EM1 are indicated as MO, M2 and M1, respectively.
- ② Class
Z: 200V None: 400V A: 600V
B: 800V C: 1000V F: 1500V
But EU02A is indicated as A2 and EU2YX as Y.
- ③ Manufacturing date
First letter: Year (Last digit of year)
Second letter: Month (1 to 9, O, N, D)
- ④ Manufacturing period
• First 10 days of month
•• Middle 10 days of month
••• Last 10 days of month

3 Axial (R1, R2, R3, R4)



- ① Part Number: 2 set marking
- ② Manufacturing date and period: 2 set marking
First letter: Year (Last digit of year)
Second letter: Month (1 to 9, O, N, D)
• First 10 days of month
•• Middle 10 days of month
••• Last 10 days of month
- ③ Cathode band
Color of the band:

White:	For Power Supply and SBD
Yellow:	For Medium speed
Red:	For Fast and ultrafast

4 TO-220F type

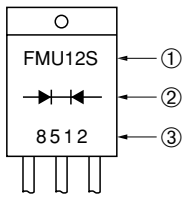

- ① Part Number
FMU-12S is indicated as "FMU12S."
- ② Polarity: Rectifier Symbol
- ③ Lot No.
First letter: Year (Last digit of year)
Second letter: Month (1 to 9, O, N, D)
Third and fourth letters: Day
Laser marking or White ink marking

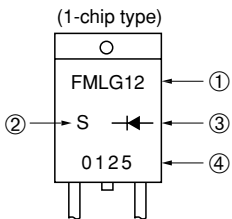

- ① Part Number: Excluding last letter
FML-G12S is indicated as "FML-G12."
- ② Last letter of Part Number
- ③ Polarity: Rectifier Symbol
- ④ Lot No.
First letter: Year (Last digit of year)
Second letter: Month (1 to 9, O, N, D)
Third and fourth letters: Day
Laser marking or White ink marking

5 TO-3PF, FM100 type



- ① Part Number: Full name
- ② Polarity: Rectifier Symbol
- ③ Lot No.
First letter: Year (Last digit of year)
Second letter: Month (1 to 9, O, N, D)
Third and fourth letters: Day
Laser marking or White ink marking

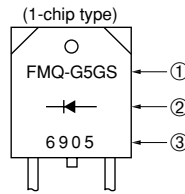

6 Surface-Mount (SJP)



- ① Part Number
- ② Polarity: Rectifier Symbol
- ③ Lot No.
First letter: Year (Last digit of year)
Second letter: Month (1 to 9, O, N, and D)
Third and fourth letters: Day

7 Surface-Mount (TO-220S)

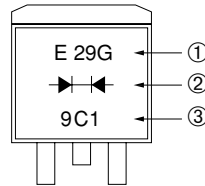

- ① Part Number
- ② Polarity: Rectifier Symbol
- ③ Lot No.
First letter: Year (Last digit of year)
Second letter: Month (A to M except I)
Third letter: Week

8 SZ-10 Series



- ① Part Number
- ② Lot No.
First letter: Year (Last digit of year)
Second letter: Month (1 to 9, O, N, and D)
Third letter: Day

9 Silicon Varistors

Refer to P217

4-1 Rectifier Diodes

●Surface-Mount

V _{RM} (V)	I _F (AV) (A) <small>Values in parentheses are for the products with heatsinks</small>	Package	Part Number	I _{FSM} (A)	T _J (°C)	T _{stg} (°C)	V _F (V) max	I _F (A)	I _R (μA)	I _{R(H)} (μA)	T _J (°C)	R _{th(j-l)} R _{th(j-c)} (°C/W)	Mass (g)
				50Hz <small>Single Half Sine Wave</small>					V _R =V _{RM} max	V _R =V _{RM} max			
400	2.0	Surface-Mount (SJP)	SJPM-H4	45	-40 to +150		1.1	2.0	10	50	150	20	0.072

●Thru-Hole

V _{RM} (V)	I _F (AV) (A) <small>Values in parentheses are for the products with heatsinks</small>	Package Axial <small>(Body Diameter/Lead Diameter)</small>	Part Number	I _{FSM} (A)	T _J (°C)	T _{stg} (°C)	V _F (V) max	I _F (A)	I _R (μA)	I _{R(H)} (μA)	T _J (°C)	R _{th(j-l)} R _{th(j-c)} (°C/W)	Mass (g)
				50Hz <small>Single Half Sine Wave</small>					V _R =V _{RM} max	V _R =V _{RM} max			
100	1.0	Axial(φ2.7/φ0.78)	EM 1Y	45	-40 to +150		0.97	1.0	10	500	150	17	0.3
	3.0	Axial(φ6.5/φ1.4)	RM 4Y	200	-40 to +150		0.95	3.0	10	50	150	8.0	1.2
200	1.0	Axial(φ2.4/φ0.6)	AM01Z	35	-40 to +150		0.98	1.0	10	50	100(Ta)	22	0.13
	1.0	Axial(φ2.7/φ0.6)	EM01Z	45	-40 to +150		0.97	1.0	10	50	100	20	0.2
	1.0	Axial(φ2.7/φ0.78)	EM 1Z	45	-40 to +150		0.97	1.0	10	500	150	17	0.3
	1.0	Axial(φ4.0/φ0.78)	RM 1Z	50	-40 to +150		0.95	1.0	5.0	50	100	15	0.4
	1.2	Axial(φ4.0/φ0.98)	RO 2Z	80	-40 to +150		0.92	1.5	10	50	100(Ta)	12	0.61
	1.2	Axial(φ4.0/φ0.98)	RM 2Z	100	-40 to +150		0.91	1.5	10	50	100	12	0.6
	1.5	Axial(φ4.0/φ0.78)	RM 10Z	120	-40 to +150		0.91	1.5	10	50	100(Ta)	15	0.4
	3.0	Axial(φ6.5/φ1.4)	RM 4Z	200	-40 to +150		0.95	3.0	10	50	100(Ta)	8.0	1.2
10	TO-220F(Center-tap)	FMM-22S, R	100	-40 to +150		1.1	5.0	10	100	150	4.0	2.1	
400	1.0	Axial(φ2.4/φ0.6)	AM01	35	-40 to +150		0.98	1.0	10	50	100(Ta)	22	0.13
	1.0	Axial(φ2.7/φ0.6)	EM01	45	-40 to +150		0.97	1.0	10	50	100(Ta)	20	0.2
	1.0	Axial(φ2.7/φ0.78)	EM 1	45	-40 to +150		0.97	1.0	10	500	150	17	0.3
	1.0	Axial(φ4.0/φ0.78)	RM 1	50	-40 to +150		0.95	1.0	5.0	50	100(Ta)	15	0.4
	1.2	Axial(φ2.7/φ0.78)	EM 2	80	-40 to +150		0.92	1.2	10	500	150	17	0.3
	1.2	Axial(φ4.0/φ0.98)	RO 2	80	-40 to +150		0.92	1.5	10	50	100(Ta)	12	0.61
	1.2	Axial(φ4.0/φ0.98)	RM 2	100	-40 to +150		0.91	1.5	10	50	100	12	0.6
	1.2	Axial(φ4.0/φ0.78)	RM 10	150	-40 to +150		0.91	1.5	10	50	100	15	0.4
	3.0	Axial(φ6.5/φ1.4)	RM 4	200	-40 to +150		0.95	3.0	10	50	150	8.0	1.2
	10	TO-220F(Center-tap)	FMM-24S, R	100	-40 to +150		1.1	5.0	10	100	150	4.0	2.1
600	1.0	Axial(φ2.4/φ0.6)	AM01A	35	-40 to +150		0.98	1.0	10	50	100(Ta)	22	0.13
	1.0	Axial(φ2.7/φ0.6)	EM01A	45	-40 to +150		0.97	1.0	10	50	100(Ta)	20	0.2
	1.0	Axial(φ2.7/φ0.78)	EM 1A	45	-40 to +150		0.97	1.0	10	500	150	17	0.3
	1.0	Axial(φ4.0/φ0.78)	RM 1A	50	-40 to +150		0.95	1.0	5.0	50	100	15	0.4
	1.2	Axial(φ2.7/φ0.78)	EM 2A	80	-40 to +150		0.92	1.2	10	50	100	17	0.3
	1.2	Axial(φ4.0/φ0.78)	RM 11A	100	-40 to +150		0.92	1.5	10	50	100	15	0.4
	1.2	Axial(φ4.0/φ0.98)	RM 2A	100	-40 to +150		0.91	1.5	10	50	100	12	0.6
	1.2	Axial(φ4.0/φ0.78)	RM 10A	150	-40 to +150		0.91	1.5	10	50	100	15	0.4
	3.0	Axial(φ6.5/φ1.4)	RM 4A	200	-40 to +150		0.95	3.0	10	50	150	8.0	1.2
	3.2	Axial(φ6.5/φ1.4)	RM 4AM	350	-40 to +150		0.92	3.5	10	50	100	8.0	1.2
10	TO-220F(Center-tap)	FMM-26S, R	100	-40 to +150		1.1	5.0	10	100	150	4.0	2.1	
800	0.8	Axial(φ4.0/φ0.78)	RM 1B	40	-40 to +150		1.2	1.0	5.0	50	100(Ta)	15	0.4
	1.0	Axial(φ2.7/φ0.78)	EM 1B	35	-40 to +150		1.05	1.0	20	200	150	17	0.3
	1.2	Axial(φ2.7/φ0.78)	EM 2B	80	-40 to +150		0.92	1.2	10	500	150	17	0.3
	1.2	Axial(φ4.0/φ0.78)	RM 11B	100	-40 to +150		0.92	1.5	10	50	100(Ta)	15	0.4
	1.2	Axial(φ4.0/φ0.98)	RM 2B	100	-40 to +150		0.91	1.5	10	50	100	12	0.6
	1.2	Axial(φ4.0/φ0.78)	RM 10B	150	-40 to +150		0.91	1.5	10	50	100(Ta)	15	0.4
1000	0.8	Axial(φ4.0/φ0.78)	RM 1C	40	-40 to +150		1.2	1.0	5.0	100	100(Ta)	15	0.4
	1.0	Axial(φ2.7/φ0.78)	EM 1C	35	-40 to +150		1.05	1.0	20	200	150	17	0.3
	1.2	Axial(φ4.0/φ0.98)	RO 2C	80	-40 to +150		0.92	1.5	10	50	100(Ta)	12	0.61
	1.2	Axial(φ4.0/φ0.78)	RM 11C	100	-40 to +150		0.92	1.5	10	50	100	15	0.4
	1.2	Axial(φ4.0/φ0.98)	RM 2C	100	-40 to +150		0.91	1.5	10	50	100	12	0.6
	3.0	Axial(φ6.5/φ1.4)	RM 4C	150	-40 to +150		0.97	3.0	10	50	100	8.0	1.2

4-2 Fast Recovery Diodes

●Thru-Hole

V _{RM} (V)	I _F (AV) (A) <small>Values in parentheses are for the products with heatsinks</small>	Package Axial <small>Body Diameter/Lead Diameter</small>	Part Number	I _{FSM} (A) <small>50Hz Single Half Sine Wave</small>	T _j (°C)	T _{stg} (°C)	V _F (V) max	I _F (A)	I _R (μA)	I _R (H) (μA)	T _j (°C)	trr ⁽¹⁾ (μs)	I _F /I _{RP} (mA)	trr ⁽²⁾ (μs)	I _F /I _{RP} (mA)	R _{th(j-l)} R _{th(j-c)} (°C/W)	Mass (g)
									V _R =V _{RM} max	V _R =V _{RM} max							
200	0.5	Axial(φ2.7/φ0.6)	EU01Z	15	-40 to +150	1.0	0.5	10	150	100(Ta)	0.4	10/10	0.18	10/20	20	0.2	
	0.5	Axial(φ2.7/φ0.78)	EU 1Z	15	-40 to +150	1.0	0.5	10	150	100(Ta)	0.4	10/10	0.18	10/20	17	0.3	
	0.5	Axial(φ2.4/φ0.6)	AU01Z	15	-40 to +150	1.7	0.5	10	150	100(Ta)	0.4	10/10	0.18	10/20	22	0.13	
	0.6	Axial(φ4.0/φ0.78)	RH 1Z	35	-40 to +150	1.3	0.6	5.0	70	150(Ta)	4.0	10/10	1.3	10/20	15	0.4	
	0.7	Axial(φ2.7/φ0.78)	ES 1Z	30	-40 to +150	2.5	0.8	10	200	100(Ta)	1.5	10/10	0.6	10/20	17	0.3	
	0.8	Axial(φ2.4/φ0.6)	AU02Z	25	-40 to +150	1.3	0.8	10	250	100	0.4	10/10	0.18	10/20	22	0.13	
	1.0	Axial(φ2.7/φ0.6)	EU02Z	15	-40 to +150	1.4	1.0	10	300	100	0.4	10/10	0.18	10/20	20	0.2	
	1.0	Axial(φ2.7/φ0.78)	EU 2Z	15	-40 to +150	1.4	1.0	10	3000	150	0.4	10/10	0.18	10/20	17	0.3	
	1.0	Axial(φ4.0/φ0.78)	RU 2Z	20	-40 to +150	1.5	1.0	10	300	100(Ta)	0.4	10/10	0.18	10/20	15	0.4	
	3.5	Axial(φ6.5/φ1.4)	RU 4Z	70	-40 to +150	1.3	3.5	10	300	100	0.4	10/10	0.18	10/20	8.0	1.2	
	5.0	TO-220F(Center-tap)	FMU-12S, R	30	-40 to +150	1.5	2.5	50	500	100(Ta)	0.4	100/100	0.18	100/200	4.0	2.1	
10	TO-220F(Center-tap)	FMU-22S, R	40	-40 to +150	1.5	5.0	50	3000	150	0.4	100/100	0.18	100/200	4.0	2.1		
400	0.25	Axial(φ2.7/φ0.6)	EU01	15	-40 to +150	2.5	0.25	10	150	100(Ta)	0.4	10/10	0.18	10/20	20	0.2	
	0.25	Axial(φ2.7/φ0.78)	EU 1	15	-40 to +150	2.5	0.25	10	150	100(Ta)	0.4	10/10	0.18	10/20	17	0.3	
	0.25	Axial(φ4.0/φ0.78)	RU 1	15	-40 to +150	2.5	0.25	10	200	100(Ta)	0.4	10/10	0.18	10/20	15	0.4	
	0.5	Axial(φ2.4/φ0.6)	AU01	15	-40 to +150	1.7	0.5	10	150	100(Ta)	0.4	10/10	0.18	10/20	22	0.13	
	0.6	Axial(φ2.4/φ0.6)	AS01	20	-40 to +150	1.5	0.6	10	50	100	1.5	10/10	0.6	10/20	22	0.13	
	0.6	Axial(φ2.7/φ0.78)	EH 1	30	-40 to +150	1.35	0.6	10	200	100(Ta)	4.0	10/10	1.3	10/20	17	0.3	
	0.7	Axial(φ2.7/φ0.78)	ES 1	30	-40 to +150	2.5	0.8	10	200	100(Ta)	1.5	10/10	0.6	10/20	17	0.3	
	0.8	Axial(φ2.4/φ0.6)	AU02	25	-40 to +150	1.3	0.8	10	250	100	0.4	10/10	0.18	10/20	22	0.13	
	1.0	Axial(φ2.7/φ0.6)	EU02	15	-40 to +150	1.4	1.0	10	300	100	0.4	10/10	0.18	10/20	20	0.2	
	1.0	Axial(φ2.7/φ0.78)	EU 2	15	-40 to +150	1.4	1.0	10	300	100	0.4	10/10	0.18	10/20	17	0.3	
	1.1	Axial(φ4.0/φ0.78)	RU 2M	20	-40 to +150	1.2	1.1	10	300	100	0.4	10/10	0.18	10/20	15	0.4	
	1.5	Axial(φ4.0/φ0.98)	RU 3	20	-40 to +150	1.5	1.5	10	400	100	0.4	10/10	0.18	10/20	12	0.6	
	1.5	Axial(φ4.0/φ0.98)	RU 3M	50	-40 to +150	1.1	1.5	10	350	100	0.4	10/10	0.18	10/20	12	0.6	
	1.5(3.0)	Axial(φ6.5/φ1.4)	RU 4	50	-40 to +150	1.5	3.0	10	300	100(Ta)	0.4	10/10	0.18	10/20	8.0	1.2	
	2.0(3.5)	Axial(φ6.5/φ1.4)	RU 4M	70	-40 to +150	1.3	3.5	10	300	100	0.4	100/100	0.18	100/200	8.0	1.2	
5.0	TO-220F(Center-tap)	FMU-14S, R	30	-40 to +150	1.5	2.5	50	500	100(Ta)	0.4	100/100	0.18	100/200	4.0	2.1		
10	TO-220F(Center-tap)	FMU-24S, R	40	-40 to +150	1.5	5.0	50	3000	150	0.4	100/100	0.18	100/200	4.0	2.1		
600	0.25	Axial(φ4.0/φ0.78)	RU 1A	15	-40 to +150	2.5	0.25	10	150	100	0.4	10/10	0.18	10/20	15	0.4	
	0.5	Axial(φ2.4/φ0.6)	AU01A	15	-40 to +150	1.7	0.5	10	150	100(Ta)	0.4	10/10	0.18	10/20	22	0.13	
	0.6	Axial(φ4.0/φ0.78)	RF 1A	15	-40 to +150	2.0	0.6	10	200	100(Ta)	0.4	10/10	0.18	10/20	15	0.4	
	0.6	Axial(φ2.4/φ0.6)	AS01A	20	-40 to +150	1.5	0.6	10	50	100	1.5	10/10	0.6	10/20	22	0.13	
	0.6	Axial(φ4.0/φ0.78)	RH 1A	35	-40 to +150	1.3	0.6	5.0	70	150(Ta)	4.0	10/10	1.3	10/20	15	0.4	
	0.7	Axial(φ2.7/φ0.6)	ES01A	20	-40 to +150	3.0	0.8	10	200	100(Ta)	1.5	10/10	0.6	10/20	20	0.2	
	0.7	Axial(φ4.0/φ0.78)	RS 1A	30	-40 to +150	2.5	0.8	10	2000	150	1.5	10/10	0.6	10/20	15	0.4	
	0.8	Axial(φ2.4/φ0.6)	AU02A	25	-40 to +150	1.3	0.8	10	250	100(Ta)	0.4	10/10	0.18	10/20	22	0.13	
	1.0	Axial(φ2.7/φ0.6)	EU02A	15	-40 to +150	1.4	1.0	10	300	100	0.4	10/10	0.18	10/20	20	0.2	
	1.0	Axial(φ2.7/φ0.78)	EU 2A	15	-40 to +150	1.4	1.0	10	300	100(Ta)	0.4	10/10	0.18	10/20	17	0.3	
	1.0	Axial(φ4.0/φ0.78)	RU 2	20	-40 to +150	1.5	1.0	10	300	100(Ta)	0.4	10/10	0.18	10/20	15	0.4	
	1.1	Axial(φ4.0/φ0.78)	RU 2AM	20	-40 to +150	1.2	1.1	10	300	100	0.4	10/10	0.18	10/20	15	0.4	
	1.5	Axial(φ4.0/φ0.98)	RU 3A	20	-40 to +150	1.5	1.5	10	400	100	0.4	10/10	0.18	10/20	12	0.6	
	1.5	Axial(φ4.0/φ0.78)	RU 20A	50	-40 to +150	1.1	1.5	10	350	100	0.4	10/10	0.18	10/20	15	0.4	
	1.5	Axial(φ4.0/φ0.98)	RU 3AM	50	-40 to +150	1.1	1.5	10	350	100	0.4	10/10	0.18	10/20	12	0.6	
	1.5(3.0)	Axial(φ6.5/φ1.4)	RU 4A	50	-40 to +150	1.5	3.0	10	300	100(Ta)	0.4	10/10	0.18	10/20	8	1.2	
	3.0	Axial(φ4.0/φ0.98)	RY 2A	50	-40 to +150	1.15	3.0	10	1000	150	0.2	100/100	0.1	100/200	12	0.6	
	3.0	TO-220F2Pin	FMU-1036S	50	-40 to +150	1.15	3.0	10	1000	150	0.2	100/100	0.1	100/200	4.0	2.1	
	5.0	TO-220F2Pin	FMU-G16S	30	-40 to +150	1.25	5.0	50	500	100(Ta)	0.4	100/100	0.18	100/200	4.0	2.1	
	5.0	TO-220F(Center-tap)	FMU-16S, R	30	-40 to +150	1.5	2.5	50	500	100(Ta)	0.4	100/100	0.18	100/200	4.0	2.1	
10	TO-220F(Center-tap)	FMU-26S, R	40	-40 to +150	1.5	5.0	50	3000	150	0.4	100/100	0.18	100/200	4.0	2.1		
10	TO-220F2Pin	FMU-G26S	40	-40 to +150	1.35	10	50	500	150	0.4	100/100	0.18	100/200	4.0	2.1		
10	TO-220F2Pin	FMU-1106S	180	-40 to +150	1.15	10	30	3000	150	0.2	100/100	0.1	100/200	4.0	2.1		
20	TO-220F(Center-tap)	FMU-2206S*	180	-40 to +150	1.15	10	30	3000	150	0.2	100/100	0.1	100/200	4.0	2.1		

*Under development

V _{RM} (V)	I _F (AV) (A) <small>Values in parentheses are for the products with heatsinks</small>	Package Axial <small>Body Diameter/Lead Diameter</small>	Part Number	I _{FSM} (A)	T _j (°C)	T _{stg} (°C)	V _F (V) max	I _F (A)	I _R (μA) V _R =V _{RM} max	I _R (H) (μA) V _R =V _{RM} max	T _j (°C)	trr ⁽¹⁾ (μs)	I _F /I _{RP} (mA)	trr ⁽²⁾ (μs)	I _F /I _{RP} (mA)	R _{th(j-l)} R _{th(j-c)} (°C/W)	Mass (g)
				50Hz Single Half Sine Wave													
800	0.25	Axial(φ4.0/φ0.78)	RU 1B	15	-40 to +150	2.5	0.25	10	200	100(Ta)	0.4	10/10	0.18	10/20	15	0.4	
	0.6	Axial(φ4.0/φ0.78)	RF 1B	15	-40 to +150	2.0	1.0	10	200	100	0.4	10/10	0.18	10/20	15	0.4	
	0.6	Axial(φ4.0/φ0.78)	RH 1B	35	-40 to +150	1.3	0.6	5.0	70	150(Ta)	4.0	10/10	1.3	10/20	15	0.4	
	0.7	Axial(φ4.0/φ0.78)	RS 1B	30	-40 to +150	2.5	0.8	10	2000	150	1.5	10/10	0.6	10/20	15	0.4	
	1.0	Axial(φ4.0/φ0.78)	RU 2B	20	-40 to +150	1.5	1.0	10	300	100	0.4	10/10	0.18	10/20	15	0.4	
	1.1	Axial(φ4.0/φ0.98)	RU 3B	20	-40 to +150	1.5	1.0	10	400	100	0.4	10/10	0.18	10/20	12	0.6	
	1.5(3.0)	Axial(φ6.5/φ1.4)	RU 4B	50	-40 to +150	1.6	3.0	10	500	100(Ta)	0.4	10/10	0.18	10/20	8.0	1.2	
1000	0.2	Axial(φ4.0/φ0.78)	RU 1C	15	-40 to +150	3.0	0.25	10	250	100	0.4	10/10	0.18	10/20	15	0.4	
	0.6	Axial(φ4.0/φ0.78)	RH 1C	35	-40 to +150	1.3	0.6	5.0	70	150(Ta)	4.0	10/10	1.3	10/20	15	0.4	
	0.8	Axial(φ4.0/φ0.78)	RU 2C	20	-40 to +150	1.5	1.0	10	300	100(Ta)	0.4	10/10	0.18	10/20	15	0.4	
	1.5	Axial(φ4.0/φ0.98)	RU 3C	20	-40 to +150	2.5	1.5	10	400	100	0.4	10/10	0.18	10/20	12	0.6	
	1.5(2.5)	Axial(φ6.5/φ1.4)	RU 4C	50	-40 to +150	1.6	3.0	50	500	100	0.4	100/100	0.18	100/200	8.0	1.2	
1300	1.5	Axial(φ6.5/φ1.4)	RU 4D	50	-40 to +150	1.8	1.5	50	500	100	0.4	500/500	0.18	500/1000	8.0	1.2	
	1.5(2.5)	Axial(φ6.5/φ1.4)	RU 4DS	50	-40 to +150	1.6	3.0	10	500	100	0.4	500/500	0.18	500/1000	8.0	1.2	
1500	0.5	Axial(φ2.7/φ0.6)	ES01F	15	-40 to +150	2.0	0.5	10	200	100(Ta)	1.5	10/10	0.6	10/20	20	0.2	
	0.5	Axial(φ2.7/φ0.78)	ES 1F	20	-40 to +150	2.0	0.5	10	200	100(Ta)	1.5	10/10	0.6	10/20	17	0.3	
	1.5(2.5)	Axial(φ6.5/φ1.4)	RS 4FS	50	-40 to +150	1.5	3.0	50	500	100	1.0	100/100	0.4	100/200	8.0	1.2	
2000	0.2	Axial(φ4.0/φ0.78)	RC 2	20	-40 to +150	2.0	0.2	10	300	100	4.0	10/10	1.3	10/20	15	0.4	

4-3 Ultrafast Recovery Diodes

●Surface-Mount

V _{RM} (V)	I _F (AV) (A) <small>Values in parentheses are for the products with heatsinks</small>	Package	Part Number	I _{FSM} (A) 50Hz <small>Single Half Sine Wave</small>	T _j (°C)	T _{stg} (°C)	V _F (V) max	I _R		T _j (°C)	trr ⁽¹⁾ (ns)	trr ⁽²⁾		R _{th(j-l)} (°C/W)	Mass (g)	
								I _F (A)	I _R (μA) V _R =V _{RM} max			I _R (H) (mA) V _R =V _{RM} max	I _F /I _{RP} (mA)			I _F /I _{RP} (mA)
200	1.0	Surface-Mount (SJP)	SJPL-D2	25	-40 to +150	0.98	1.0	25	0.1	150	50	100/100	35	100/200	20	0.072
	1.5	Surface-Mount (SJP)	SJPX-F2	30	-40 to +150	0.98	1.5	10	2.0	150	30	100/100	25	100/200	20	0.072
	2.0	Surface-Mount (SJP)	SJPL-H2	25	-40 to +150	0.98	2.0	50	0.2	150	50	100/100	35	100/200	20	0.072
	3.0	Surface-Mount (SJP)	SJPL-L2	60	-40 to +150	0.98	3.0	50	0.3	150	50	100/100	35	100/200	20	0.072
	10	Surface-Mount (TO220S)	MPL-102S	65	-40 to +150	0.98	5.0	100	0.2	150(Ta)	40	100/100	30	100/200	2.5	1.4
300	2.0	Surface-Mount (SJP)	SJPX-H3	20	-40 to +150	1.3	2.0	50	3.0	150	30	100/100	25	100/200	20	0.072
400	1.5	Surface-Mount(SJP)	SJPL-F4	25	-40 to +150	1.3	1.5	10	0.05	150(Ta)	50	100/100	35	100/200	20	0.072
	3.0	Surface-Mount(SJP)	SJPL-L4	30	-40 to +150	1.3	3.0	50	0.1	150	50	100/100	35	100/200	20	0.072
500	1.0	Surface-Mount(SJP)	SJPD-D5*	20	-40 to +150	1.4	1.0	10	0.1	150	40	100/100	30	100/200	20	0.072
	3.0	Surface-Mount(SJP)	SJPD-L5	50	-40 to +150	1.4	3.0	15	0.15	150	50	100/100	35	100/200	20	0.072
600	2.0	Surface-Mount (SJP)	SJPL-H6	30	-40 to +150	1.5	2.0	50	0.1	150	50	100/100	35	100/200	20	0.072
	2.0	Surface-Mount (SJP)	SJPX-H6	20	-40 to +150	1.5	2.0	10	3.0	150	30	100/100	20	100/200	20	0.072
	3.0	Surface-Mount (TO220S)	MPL-1036S	50	-40 to +150	1.75	3.0	50	0.1	150	50	100/100	-	-	2.5	1.4

*Under development

●Thru-Hole

V _{RM} (V)	I _F (AV) (A) <small>Values in parentheses are for the products with heatsinks</small>	Package Axial <small>(Body Diameter/Lead Diameter)</small>	Part Number	I _{FSM} (A) 50Hz <small>Single Half Sine Wave</small>	T _j (°C)	T _{stg} (°C)	V _F (V) max	I _R		T _j (°C)	trr ⁽¹⁾ (ns)	trr ⁽²⁾		R _{th(j-l)} (°C/W)	Mass (g)	
								I _F (A)	I _R (μA) V _R =V _{RM} max			I _R (H) (mA) V _R =V _{RM} max	I _F /I _{RP} (mA)			I _F /I _{RP} (mA)
200	1.0	Axial (φ 2.4/ φ 0.6)	AL01Z	25	-40 to +150	0.98	1.0	50	0.1	100	50	100/100	35	100/200	22	0.13
	1.5	Axial (φ 2.7/ φ 0.6)	EN01Z	50	-40 to +150	0.92	1.5	10	2.0	150	100	100/100	50	100/200	20	0.2
	1.5	Axial (φ 2.7/ φ 0.78)	EL 1Z	25	-40 to +150	0.98	1.5	50	0.1	100	50	100/100	35	100/200	17	0.3
	1.5	Axial (φ 2.7/ φ 0.6)	EL02Z	25	-40 to +150	0.98	1.5	50	0.1	100	40	100/100	30	100/200	20	0.2
	1.5	Axial (φ 4.0/ φ 0.78)	RN 1Z	60	-40 to +150	0.92	1.5	20	3.0	150	100	100/100	50	100/200	15	0.4
	2.0	Axial (φ 4.0/ φ 0.78)	RX 10Z	30	-40 to +150	0.98	2.0	50	3.0	150	30	100/100	25	100/200	15	0.4
	2.0	Axial (φ 4.0/ φ 0.78)	RL 10Z	30	-40 to +150	0.98	2.0	50	0.1	100(Ta)	50	100/100	35	100/200	15	0.4
	2.0	Axial (φ 4.0/ φ 0.98)	RL 2Z	30	-40 to +150	0.98	2.0	50	0.1	150	50	100/100	35	100/200	12	0.6
	2.0	Axial (φ 4.0/ φ 0.98)	RN 2Z	70	-40 to +150	0.92	2.0	50	4.0	150	100	100/100	50	100/200	12	0.6
	3.5	Axial (φ 6.5/ φ 1.4)	RL 4Z	80	-40 to +150	0.95	3.5	150	0.5	150	50	100/100	35	100/200	8.0	1.2
	3.5	Axial (φ 6.5/ φ 1.4)	RN 4Z	120	-40 to +150	0.92	3.5	50	6.0	150	100	100/100	50	100/200	8.0	1.2
	5.0	TO-220F (Center-tap)	FML-12S	35	-40 to +150	0.98	2.5	50	0.1	150	40	100/100	30	100/200	4.0	2.1
	5.0	TO-220F (Center-tap)	FMX-12S	35	-40 to +150	0.98	2.5	50	10	150	30	100/100	25	100/200	4.0	2.1
	5.0	TO-220F2Pin	FML-G12S	65	-40 to +150	0.98	5.0	100	0.2	150	40	100/100	30	100/200	4.0	2.1
	5.0	TO-220F2Pin	FMX-G12S	65	-40 to +150	0.98	5.0	100	20	150	30	100/100	25	100/200	4.0	2.1
	5.0	TO-220F2Pin	FMN-G12S	100	-40 to +150	0.92	5.0	100	10	150(Ta)	100	100/100	50	100/200	4.0	2.1
	10	TO-220F (Center-tap)	FMXA-2102ST	100	-40 to +150	1.2	5.0	100	20	150	25	500/500	-	-	4.0	2.1
	10	TO-220F (Center-tap)	FML-22S	65	-40 to +150	0.98	5.0	100	0.2	150	40	100/100	30	100/200	4.0	2.1
	10	TO-220F (Center-tap)	FMX-22S	65	-40 to +150	0.98	5.0	100	20	100(Ta)	30	100/100	25	100/200	4.0	2.1
	10	TO-220F2Pin	FML-G22S	150	-40 to +150	0.98	10	200	0.4	150	40	500/500	30	500/1000	4.0	2.1
	10	TO-220F2Pin	FMX-G22S	150	-40 to +150	0.98	10	200	50	100(Ta)	30	500/500	25	500/1000	4.0	2.1
	15	TO-220F (Center-tap)	FMX-22SL	100	-40 to +150	0.98	7.5	150	30	150	30	500/500	25	500/1000	4.0	2.1
	20	TO-220F (Center-tap)	FM2-2202	110	-40 to +150	0.98	10	200	0.4	150	50	100/100	35	100/200	4.0	2.1
	20	TO-220F (Center-tap)	FMXA-2202S	100	-40 to +150	1.2	10	100	30	150	25	500/500	-	-	4.0	2.1
	20	TO-3PF (Center-tap)	FML-4202S	150	-40 to +150	0.98	10	10	0.4	150	40	500/500	30	500/1000	2.0	6.5
20	TO-3PF (Center-tap)	FMX-4202S	150	-40 to +150	0.98	10	200	50	150	30	500/500	25	500/1000	2.0	6.5	
20	TO-3PF (Center-tap)	FMXA-4202S*	100	-40 to +150	1.2	10	100	30	150	25	500/500	-	-	2.0	6.5	
20	TO-3PF (Center-tap)	FMXS-4202S	150	-40 to +150	1.05	10	50	30	150	30	500/500	25	500/1000	2.0	6.5	
300	5.0	TO-220F (Center-tap)	FML-13S	40	-40 to +150	1.3	2.5	50	0.25	100(Ta)	50	100/100	35	100/200	4.0	2.1
	5.0	TO-220F2Pin	FML-G13S	70	-40 to +150	1.3	5.0	100	0.2	100(Ta)	50	100/100	35	100/200	4.0	2.1
	10	TO-220F (Center-tap)	FML-23S	75	-40 to +150	1.3	5.0	100	0.2	150	50	100/100	30	100/200	4.0	2.1
	10	TO-220F (Center-tap)	FMX-23S	65	-40 to +150	1.3	5.0	50	15	150	30	100/100	25	100/200	4.0	2.1
	15	TO-220F (Center-tap)	FMXA-2153S	75	-40 to +150	1.3	7.5	75	23	150	25	500/500	-	-	4.0	2.1
	20	TO-220F (Center-tap)	FMX-2203	100	-40 to +150	1.3	10	100	30	150(Ta)	30	500/500	25	500/1000	4.0	2.1
	20	TO-3PF (Center-tap)	FMX-4203S	100	-40 to +150	1.3	10	100	30	150	30	500/500	25	500/1000	2.0	6.5
	20	TO-220F (Center-tap)	FMXA-2203S	100	-40 to +150	1.3	10	100	30	150	25	500/500	-	-	4.0	2.1
20	TO-3PF (Center-tap)	FMXA-4203S	100	-40 to +150	1.3	10	100	30	150	25	500/500	-	-	2.0	6.5	

*Under development

V _{RM} (V)	I _F (AV) (A) <small>Values in parentheses are for the products with heatsinks</small>	Package Axial (Body Diameter/Lead Diameter)	Part Number	I _{FSM} (A)	T _J (°C)	T _{stg} (°C)	V _F (V) max	I _F (A)	I _R (μA) V _R =V _{RM} max	I _R (H) (mA) V _R =V _{RM} max	T _J (°C)	trr ^① (ns)	I _F /I _{RP} (mA)	trr ^② (ns)	I _F /I _{RP} (mA)	R _{th(j-l)} (°C/W)	Mass (g)
				50Hz <small>Single Half Sine Wave</small>													
400	0.7	Axial (φ 2.4/ f 0.6)	AG01	15	-40 to +150	1.8	0.7	100	0.5	100(Ta)	100	100/100	50	100/200	22	0.13	
	0.7	Axial (φ 2.7/ f 0.6)	EG01	15	-40 to +150	2.0	0.7	50	0.3	100	100	100/100	50	100/200	20	0.2	
	0.8	Axial (φ 2.7/ f 0.78)	EG 1	15	-40 to +150	1.8	0.8	50	0.3	100	100	100/100	50	100/200	17	0.3	
	1.0	Axial (φ 2.4/ f 0.6)	AL01	20	-40 to +150	1.4	1.0	10	0.05	150	50	100/100	35	100/200	22	0.13	
	1.2	Axial (φ 4.0/ f 0.78)	RG 10	50	-40 to +150	1.8	1.5	500	2.5	150	100	100/100	50	100/200	15	0.4	
	1.2	Axial (φ 4.0/ f 0.98)	RG 2	50	-40 to +150	1.8	1.5	500	2.5	150	100	100/100	50	100/200	12	0.6	
	1.5	Axial (φ 2.7/ f 0.78)	EL 1	40	-40 to +150	1.3	1.5	10	0.05	150	50	100/100	35	100/200	17	0.3	
	2.0	Axial (φ 4.0/ f 0.98)	RL 2	40	-40 to +150	1.3	2.0	10	0.1	150	50	100/100	35	100/200	12	0.6	
	5.0	TO-220F2Pin	FMXA-1054S	50	-40 to +150	1.5	5.0	50	15	150	20	500/500	-	-	4.0	2.1	
	5.0	TO-220F (Center-tap)	FMG-14S, R	35	-40 to +150	2.0	2.5	500	1.5	100	100	100/100	50	100/200	4.0	2.1	
	5.0	TO-220F (Center-tap)	FML-14S	40	-40 to +150	1.3	2.5	50	0.1	100(Ta)	50	100/100	35	100/200	4.0	2.1	
	5.0	TO-220F2Pin	FMX-G14S	70	-40 to +150	1.3	5.0	50	15	150	30	100/100	25	100/200	4.0	2.1	
	5.0	TO-220F2Pin	FML-G14S	70	-40 to +150	1.3	5.0	100	0.2	150	50	100/100	35	100/200	4.0	2.1	
	5.0	TO-220F2Pin	FMN-G14S	70	-40 to +150	1.0	5.0	50	10	150	100	100/100	50	100/200	4.0	2.1	
	8.0	TO-220F (Center-tap)	FMG-24S, R	65	-40 to +150	2.0	5.0	500	2.5	150	100	100/100	50	100/200	4.0	2.1	
	10	TO-220F (Center-tap)	FML-24S	70	-40 to +150	1.3	5.0	100	0.2	100(Ta)	50	100/100	35	100/200	4.0	2.1	
	10	TO-220F2Pin	FMXA-1104S	100	-40 to +150	1.5	10	100	30	150	25	500/500	-	-	4.0	2.1	
	20	TO-3PF (Center-tap)	FML-4204S	100	-40 to +150	1.3	10	50	0.4	150	50	500/500	35	500/1000	2.0	6.5	
	20	TO-3PF (Center-tap)	FMXA-4204S*	100	-40 to +150	1.5	10	100	30	150	25	500/500	-	-	2.0	6.5	
	20	TO-3PF (Center-tap)	FMD-4204S	100	-40 to +150	1.4	10	20	0.2	150	50	500/500	30	500/1000	2.0	6.5	
600	0.5	Axial (φ 2.7/ φ 0.6)	EG01A	10	-40 to +150	2.0	0.5	100	0.5	100	100	100/100	50	100/200	20	0.2	
	0.5	Axial (φ 2.4/ φ 0.6)	AG01A	15	-40 to +150	1.8	0.5	100	0.5	100(Ta)	100	100/100	50	100/200	22	0.13	
	0.6	Axial (φ 2.7/ φ 0.78)	EG 1A	10	-40 to +150	2.0	0.6	100	0.5	100	100	100/100	50	100/200	17	0.3	
	1.0	Axial (φ 4.0/ φ 0.78)	RG 10A	50	-40 to +150	2.0	1.0	500	1.0	150	100	100/100	50	100/200	15	0.4	
	1.0	Axial (φ 4.0/ φ 0.98)	RG 2A	50	-40 to +150	2.0	1.0	500	1.0	150	100	100/100	50	100/200	12	0.6	
	1.2	Axial (φ 4.0/ φ 0.98)	RD 2A	30	-40 to +150	1.55	1.2	50	0.1	150	50	100/100	35	100/200	12	0.6	
	3.0	TO-220F (Two elements)	FMC-26U	50	-40 to +150	2.0	3.0	500	3.0	150	70	500/500	35	500/1000	4.0	2.1	
	3.0	Axial (φ 6.5/ φ 1.4)	RL 4A	80	-40 to +150	1.5	3.0	50	0.1	150	50	500/500	35	500/1000	8.0	1.2	
	3.0	Axial (φ 6.5/ φ 1.4)	RN 4A	50	-40 to +150	1.3	3.0	50	5.0	150	100	100/100	50	100/200	8.0	1.2	
	4.0	TO-220F2Pin	FMG-G26S	50	-40 to +150	2.5	4.0	500	3.0	100(Ta)	100	100/100	50	100/200	4.0	2.1	
	5.0	TO-220F2Pin	FMX-G16S	50	-40 to +150	1.5	5.0	50	15	150	30	100/100	25	100/200	4.0	2.1	
	5.0	TO-220F2Pin	FML-G16S	50	-40 to +150	1.5	5.0	100	0.5	150	50	500/500	35	500/1000	4.0	2.1	
	5.0	TO-220F2Pin	FMN-1056S	60	-40 to +150	1.3	5.0	50	5.0	150	100	100/100	50	100/200	4.0	2.1	
	5.0	TO-220F2Pin	FMD-1056S*	90	-40 to +150	1.7	5.0	10	0.1	150	50	500/500	35	500/1000	4.0	2.1	
	6.0	TO-220F (Center-tap)	FMG-26S, R	50	-40 to +150	2.2	3.0	500	3.0	150	100	100/100	50	100/200	4.0	2.1	
	8.0	TO-220F2Pin	FMXK-1086S	100	-40 to +150	1.75	8.0	30	6.0	150	27	500/500	-	-	4.0	2.1	
	10	TO-220F2Pin	FMX-1106S	50	-40 to +150	1.5	5.0	50	15	150	30	100/100	25	100/200	4.0	2.1	
	10	TO-220F2Pin	FMX-G26S	100	-40 to +150	1.5	10	100	20	150(Ta)	30	100/100	25	100/200	4.0	2.1	
	10	TO-220F2Pin	FMD-G26S	100	-40 to +150	1.7	10	100	0.3	100(Ta)	50	500/500	30	500/1000	4.0	2.1	
	10	TO-220F2Pin	FMXA-1106S	100	-40 to +150	1.98	10	100	30	150	28	500/500	-	-	4.0	2.1	
	10	TO-220F2Pin	FMNS-1106S	100	-40 to +150	1.3	10	100	10	150	100	100/100	50	100/200	4.0	2.1	
	10	TO-220F2Pin	FMN-1106S	150	-40 to +150	1.3	10	100	10	150	100	100/100	50	100/200	4.0	2.1	
	10	TO-220F2Pin	FMD-1106S*	180	-40 to +150	1.7	10	20	0.2	150	50	500/500	35	500/1000	4.0	2.1	
	10	TO-220F2Pin	FMXK-1106S	100	-40 to +150	1.75	10	100	10	150	27	500/500	-	-	4.0	2.1	
	20	TO-220F2Pin	FMN-1206S	150	-40 to +150	1.3	20	200	20	150	150	500/500	100	500/1000	4.0	2.1	
	20	TO-220F (Center-tap)	FMN-2206S	150	-40 to +150	1.3	10	100	10	150	100	100/100	50	100/200	4.0	2.1	
	20	TO-220F (Center-tap)	FMXK-2206S	100	-40 to +150	1.75	10	100	10	150	27	500/500	-	-	4.0	2.1	
	20	TO-220F (Center-tap)	FMXS-2206S	100	-40 to +150	1.6	10	50	15	150	30	500/500	25	500/1000	4.0	2.1	
	20	TO-3PF (Center-tap)	FMD-4206S	100	-40 to +150	1.7	10	100	0.3	150	50	500/500	30	500/1000	2.0	6.5	
	20	TO-3PF (Center-tap)	FMX-4206S*	100	-40 to +150	1.5	10	100	20	150	30	500/500	-	-	2.0	6.5	
20	TO-3PF (Center-tap)	FMXA-4206S*	100	-40 to +150	1.98	10	100	30	150	28	500/500	-	-	2.0	6.5		
30	TO-3PF2Pin	FMN-3306S	150	-40 to +150	1.3	30	200	20	150	150	500/500	100	500/1000	2.0	6.5		
30	TO-3PF (Center-tap)	FMN-4306S	150	-40 to +150	1.5	15	100	10	150	100	100/100	50	100/200	2.0	6.5		

*Under development

4-3 Ultrafast Recovery Diodes

V _{RM} (V)	I _F (AV) (A) <small>Values in parentheses are for the products with heatsinks</small>	Package Axial <small>(Body Diameter/Lead Diameter)</small>	Part Number	I _{FSM} (A)	T _j (°C)	T _{stg} (°C)	V _F (V) max	I _F (A)	I _R (μA) V _R =V _{RM} max	I _R (H) (mA) V _R =V _{RM} max	T _j (°C)	trr ^① (ns)	I _F /I _{RP} (mA)	trr ^② (ns)	I _F /I _{RP} (mA)	R _{th(j-l)} (°C/W)	Mass (g)
				50Hz <small>Single Half Sine Wave</small>													
800	0.5	Axial (φ 2.4/ φ 0.6)	AB01B	10	-40 to +150	2.0	0.5	10	0.2	150	200	100/100	80	100/200	22	0.13	
	3.0	TO-220F (Two elements)	FMC-28U	50	-40 to +150	3.0	3.0	100	0.5	150	70	500/500	35	500/1000	4.0	2.1	
	3.0	TO-220F2Pin	FMC-G28S	50	-40 to +150	3.0	3.0	100	1.0	150	70	500/500	35	500/1000	4.0	2.1	
	5.0	TO-220F2Pin	FMC-G28SL	60	-40 to +150	3.0	5.0	200	2.0	150	70	500/500	35	500/1000	4.0	2.1	
1000	0.2	Axial (φ 2.4/ φ 0.6)	AP01C	5.0	-40 to +150	4.0	0.2	100	0.5	100	200	100/100	80	100/200	22	0.13	
	0.2	Axial (φ 2.7/ φ 0.6)	EP01C	5.0	-40 to +150	4.0	0.2	5.0	0.05	100(Ta)	200	100/100	80	100/200	20	0.2	
	0.4	Axial (φ 4.0/ φ 0.78)	RU 1P	10	-40 to +150	4.0	0.4	5.0	0.5	150	100	100/100	50	100/200	15	0.4	
	0.5	Axial (φ 2.7/ φ 0.6)	EG01C	10	-40 to +150	3.3	0.5	50	0.5	100(Ta)	100	100/100	50	100/200	20	0.2	
	0.7	Axial (φ 4.0/ φ 0.78)	RG 1C	10	-40 to +150	3.3	0.7	20	0.25	150	100	100/100	50	100/200	15	0.4	
	2.0	Axial (φ 6.5/ φ 1.4)	RG 4C	60	-40 to +150	3.0	2.0	500	2.5	100	100	500/500	50	500/1000	8.0	1.2	
	3.0	TO-220F2Pin	FMG-G2CS	30	-40 to +150	4.0	3.0	50	0.3	100	100	500/500	50	500/1000	4.0	2.1	
1200	3.0	TO-220F2Pin (Two elements)	FMC-26UA	50	-40 to +150	4.0	3.0	500	3.0	150	70	500/500	35	500/1000	4.0	2.1	
1600	3.0	TO-220F2Pin (Two elements)	FMC-28UA	50	-40 to +150	6.0	3.0	100	0.5	150	70	500/500	35	500/1000	4.0	2.1	
2000	0.1	Axial (φ 4.0/ φ 0.78)	RP 1H	5.0	-40 to +150	7.0	0.1	2.0	0.01	100	100	10/20	50	10/20	15	0.4	

4-4 Schottky Barrier Diodes

Standard

●Surface-Mount

V _{RM} (V)	I _F (AV) (A)	Package	Part Number	I _{FSM} (A)	T _j (°C)	T _{stg} (°C)	V _F (V) max	I _F (A)	I _R (mA)	I _{R(H)} (mA)	T _j (°C)	R _{th(j-l)} R _{th(j-c)} (°C/W)	Mass (g)
				50Hz Single Half Sine Wave					V _R =V _{RM} max	V _R =V _{RM} max			
40	1.0	Surface-Mount (SJP)	SJPB-D4	30	-40 to +150	0.55	1.0	0.1	35	150	20	0.072	
	2.0	Surface-Mount (SJP)	SJPB-H4	50	-40 to +150	0.55	2.0	0.2	70	150	20	0.072	
	3.0	Surface-Mount (SJP)	SJPB-L4	60	-40 to +150	0.55	3.0	0.3	100	150	20	0.072	
	5.0	Surface-Mount (SJP)	SJPW-T4	80	-40 to +150	0.55	5.0	0.5	150	150	20	0.072	
60	1.0	Surface-Mount (SJP)	SJPB-D6	20	-40 to +150	0.68	1.0	0.1	30	150	20	0.072	
	1.5	Surface-Mount (SJP)	SJPW-F6	25	-40 to +150	0.70	1.5	1.0	70	150	20	0.072	
	2.0	Surface-Mount (SJP)	SJPB-H6	40	-40 to +150	0.69	2.0	0.2	55	150	20	0.072	
	3.0	Surface-Mount (SJP)	SJPB-L6	50	-40 to +150	0.70	3.0	0.3	70	150	20	0.072	
90	1.0	Surface-Mount (SJP)	SJPB-D9	20	-40 to +150	0.85	1.0	0.1	30	150	20	0.072	
	2.0	Surface-Mount (SJP)	SJPB-H9	40	-40 to +150	0.85	2.0	0.2	55	150	20	0.072	
100	20	Surface-Mount (TO220S)Center-tap	MPE-220A	120	-40 to +150	0.85	10	1.0	100	150	2.5	1.04	

●Thru-Hole

V _{RM} (V)	I _F (AV) (A)	Package Axial (Body Diameter/Lead Diameter)	Part Number	I _{FSM} (A)	T _j (°C)	T _{stg} (°C)	V _F (V) max	I _F (A)	I _R (mA)	I _{R(H)} (mA)	T _j (°C)	R _{th(j-l)} R _{th(j-c)} (°C/W)	Mass (g)
				50Hz Single Half Sine Wave					V _R =V _{RM} max	V _R =V _{RM} max			
40	1.0	Axial(φ2.4/φ0.6)	AK 04	25	-40 to +150	0.55	1.0	5.0	35	150	22	0.13	
	1.0	Axial(φ2.7/φ0.6)	EK 04	40	-40 to +150	0.55	1.0	5.0	35	150	20	0.3	
	1.5	Axial(φ2.7/φ0.78)	EK 14	40	-40 to +150	0.55	1.5	5.0	50	150	17	0.3	
	1.7	Axial(φ4.0/φ0.78)	RK 14	60	-40 to +150	0.55	2.0	5.0	70	150	15	0.45	
	2.5	Axial(φ4.0/φ0.98)	RK 34	50	-40 to +150	0.55	2.5	5.0	100	150	12	0.6	
	3.0	TO-220F2Pin	FMB-G14	60	-40 to +150	0.60	3.0	2.0	70	150	4.0	2.1	
	3.0	Axial(φ6.5/φ1.4)	RK 44	80	-40 to +150	0.55	3.0	5.0	100	150	8.0	1.2	
	4.0	TO-220F(Center-tap)	FMB-24	50	-40 to +150	0.55	2.0	5.0	250	150	4.0	2.1	
	5.0	Axial(φ6.5/φ1.4)	RW54	120	-40 to +150	0.55	5.0	1.0	150	150	8.0	1.2	
	5.0	TO-220F2Pin	FMB-G14L	60	-40 to +150	0.55	5.0	5.0	175	150	4.0	2.1	
	6.0	TO-220F(Center-tap)	FMB-24M	60	-40 to +150	0.55	3.0	5.0	100	150	4.0	2.1	
	10	TO-220F(Center-tap)	FMB-24L	60	-40 to +150	0.55	5.0	5.0	175	150	4.0	2.1	
	10	TO-220F(Center-tap)	FMW-24L	100	-40 to +150	0.55	5.0	0.5	175	150	4.0	2.1	
	10	TO-220F2Pin	FMB-G24H	150	-40 to +150	0.55	10	10	350	150	4.0	2.1	
	15	TO-220F(Center-tap)	FMB-24H	100	-40 to +150	0.55	7.5	7.5	250	150	4.0	2.1	
	15	TO-220F(Center-tap)	FMW-24H	120	-40 to +150	0.55	7.5	7.5	250	150	4.0	2.1	
	20	TO-220F(Center-tap)	FMB-2204	150	-40 to +150	0.55	10	10	350	150	4.0	2.1	
	20	TO-220F(Center-tap)	FMW-2204	120	-40 to +150	0.55	10	1.0	350	150	4.0	2.1	
	30	TO-220F(Center-tap)	FMB-2304	150	-40 to +150	0.55	15	15	500	150	4.0	2.1	
	30	TO-3PF(Center-tap)	FMW-4304	150	-40 to +150	0.55	15	1.5	500	150	2.0	6.5	

4-4 Schottky Barrier Diodes

V _{RM} (V)	I _F (AV) (A)	Package Axial (Body Diameter/Lead Diameter)	Part Number	I _{FSM} (A)	T _J (°C)	T _{stg} (°C)	V _F (V) max	I _F (A)	I _R (mA)	I _{R(H)} (mA)	T _J (°C)	R _{th(j-l)} R _{th(j-c)} (°C/W)	Mass (g)
				50Hz Single Half Sine Wave					V _R =V _{RM} max	V _R =V _{RM} max			
60	0.7	Axial(φ2.4/φ0.6)	AK 06	10	-40 to +150		0.62	0.7	1.0	30	150	22	0.13
	0.7	Axial(φ2.7/φ0.6)	EK 06	10	-40 to +150		0.62	0.7	1.0	30	150	20	0.3
	1.5	Axial(φ2.7/φ0.78)	EK 16	25	-40 to +150		0.62	1.5	1.0	55	150	17	0.3
	1.5	Axial(φ4.0/φ0.78)	RK 16	25	-40 to +150		0.62	1.5	1.0	55	150	15	0.45
	2.0	Axial(φ4.0/φ0.98)	RK 36	40	-40 to +150		0.62	2.0	2.0	70	150	12	0.6
	3.5	Axial(φ6.5/φ1.4)	RK 46	70	-40 to +150		0.62	3.5	3.0	125	150	8.0	1.2
	4.0	TO-220F(Center-tap)	FMB-26	40	-40 to +150		0.62	2.0	2.0	70	150	4.0	2.1
	6.0	TO-220F2Pin	FMB-G16L	50	-40 to +150		0.72	6.0	5.0	200	150	4.0	2.1
	10	TO-220F(Center-tap)	FMW-2106	100	-40 to +150		0.70	5.0	3.0	125	150	4.0	2.1
	15	TO-220F(Center-tap)	FMW-2156	100	-40 to +150		0.70	7.5	5.0	175	150	4.0	2.1
	20	TO-220F(Center-tap)	FMW-2206	120	-40 to +150		0.70	10	1.0	250	150	4.0	2.1
	30	TO-220F(Center-tap)	FMB-2306	150	-40 to +150		0.70	15	8.0	400	150	4.0	2.1
30	TO-3PF(Center-tap)	FMW-4306	150	-40 to +150		0.70	15	3.0	350	150	2.0	6.5	
90	0.7	Axial(φ2.4/φ0.6)	AK 09	10	-40 to +150		0.81	0.7	1.0	30	150	22	0.13
	0.7	Axial(φ2.7/φ0.6)	EK 09	10	-40 to +150		0.81	0.7	1.0	30	150	20	0.3
	1.5	Axial(φ2.7/φ0.78)	EK 19	40	-40 to +150		0.81	1.5	2.0	55	150	17	0.3
	1.5	Axial(φ4.0/φ0.78)	RK 19	40	-40 to +150		0.81	1.5	2.0	55	150	15	0.45
	2.0	Axial(φ4.0/φ0.98)	RK 39	50	-40 to +150		0.81	2.0	3.0	70	150	12	0.6
	3.5	Axial(φ6.5/φ1.4)	RK 49	60	-40 to +150		0.81	3.5	5.0	125	150	8.0	1.2
	4.0	TO-220F(Center-tap)	FMB-29	50	-40 to +150		0.81	2.0	3.0	55	150	4.0	2.1
	4.0	TO-220F2Pin	FMB-G19L	60	-40 to +150		0.81	4.0	5.0	125	150	4.0	2.1
8.0	TO-220F(Center-tap)	FMB-29L	60	-40 to +150		0.81	4.0	5.0	125	150	4.0	2.1	

Low V_F "A Series"

●Surface-Mount

V _{RM} (V)	I _F (AV) (A)	Package	Part Number	I _{FSM} (A)	T _J (°C)	T _{stg} (°C)	V _F (V) max	I _F (A)	I _R (mA)	I _{R(H)} (mA)	T _J (°C)	R _{th(j-l)} R _{th(j-c)} (°C/W)	Mass (g)
				50Hz Single Half Sine Wave					V _R =V _{RM} max	V _R =V _{RM} max			
30	1.0	Surface-Mount (SJP)	SJPA-D3	30	-40 to +125		0.36	1.0	1.5	70	100	20	0.072
	2.0	Surface-Mount (SJP)	SJPA-H3*	40	-40 to +125		0.36	2.0	3.0	140	100	20	0.072
	3.0	Surface-Mount (SJP)	SJPA-L3	70	-40 to +125		0.36	3.0	4.5	210	100	20	0.072

*Under development

●Thru-Hole

V _{RM} (V)	I _F (AV) (A)	Package Axial (Body Diameter/Lead Diameter)	Part Number	I _{FSM} (A)	T _J (°C)	T _{stg} (°C)	V _F (V) max	I _F (A)	I _R (mA)	I _{R(H)} (mA)	T _J (°C)	R _{th(j-l)} R _{th(j-c)} (°C/W)	Mass (g)
				50Hz Single Half Sine Wave					V _R =V _{RM} max	V _R =V _{RM} max			
30	2.0	Axial(φ4.0/φ0.78)	RA 13	50	-40 to +125		0.36	2.0	3.0	140	100	15	0.45

Low IR "E Series"

●Surface-Mount

V _{RM} (V)	I _F (AV) (A)	Package Axial (Body Diameter/Lead Diameter)	Part Number	I _{FSM} (A)	T _j (°C)	T _{stg} (°C)	V _F (V) max	I _F (A)	I _R (mA)	I _{R(H)} (mA)	T _j (°C)	R _{th(j-l)} R _{th(j-c)} (°C/W)	Mass (g)
				50Hz Single Half Sine Wave					V _R =V _{RM} max	V _R =V _{RM} max			
30	2.0	Surface-Mount (SJP)	SJPE-H3*	40	-40 to +150		0.55	2.0	0.2	70	150	20	0.072
40	2.0	Surface-Mount (SJP)	SJPE-H4	40	-40 to +150		0.6	2.0	0.05	20	150	20	0.072

*Under development

●Thru-Hole

V _{RM} (V)	I _F (AV) (A)	Package	Part Number	I _{FSM} (A)	T _j (°C)	T _{stg} (°C)	V _F (V) max	I _F (A)	I _R (mA)	I _{R(H)} (mA)	T _j (°C)	R _{th(j-l)} R _{th(j-c)} (°C/W)	Mass (g)
				50Hz Single Half Sine Wave					V _R =V _{RM} max	V _R =V _{RM} max			
80	20	TO-220F(Center-tap)	FMEN-2208	120	-40 to +150		0.76	10	0.2	100	150	4.0	2.1
	30	TO-220F(Center-tap)	FMEN-2308	150	-40 to +150		0.765	15	0.3	150	150	4.0	2.1
100	10	TO-220F(Center-tap)	FMEN-210A	100	-40 to +150		0.85	5.0	0.1	50	150	4.0	2.1
	15	TO-220F(Center-tap)	FMEN-215A*	100	-40 to +150		0.85	7.5	0.15	75	150	4.0	2.1
	20	TO-220F(Center-tap)	FMEN-220A	120	-40 to +150		0.85	10	0.2	100	150	4.0	2.1
	20	TO-3PF(Center-tap)	FMEN-420A*	120	-40 to +150		0.85	10	0.2	100	150	2.0	6.5
	30	TO-220F(Center-tap)	FMEN-230A	150	-40 to +150		0.85	15	0.3	150	150	4.0	2.1
	30	TO-262	MPEN-230AF	150	-40 to +150		0.90	15	0.25	125	150	1.5	1.55
	30	TO-3PF(Center-tap)	FMEN-430A	150	-40 to +150		0.85	15	0.3	150	150	2.0	6.5
150	10	TO-220F(Center-tap)	FMEN-210B	100	-40 to +150		0.92	5.0	0.1	25	150	4.0	2.1
	20	TO-220F(Center-tap)	FMEN-220B	120	-40 to +150		0.92	10	0.2	50	150	4.0	2.1
	20	TO-3PF(Center-tap)	FMEN-420B*	120	-40 to +150		0.85	10	0.2	100	150	2.0	6.5
	30	TO-220F(Center-tap)	FMEN-230B	150	-40 to +150		0.92	15	0.3	75	150	4.0	2.1

*Under development

Low V_F/Low I_R Balance "J Series"

●Surface-Mount

V _{RM} (V)	I _F (AV) (A)	Package	Part Number	I _{FSM} (A)	T _j (°C)	T _{stg} (°C)	V _F (V) max	I _F (A)	I _R (mA)	I _{R(H)} (mA)	T _j (°C)	R _{th(j-l)} R _{th(j-c)} (°C/W)	Mass (g)
				50Hz Single Half Sine Wave					V _R =V _{RM} max	V _R =V _{RM} max			
30	1.0	Surface-Mount (SJP)	SJPJ-D3	30	-40 to +150		0.45	1.0	0.1	35	150	20	0.072
	2.0	Surface-Mount (SJP)	SJPJ-H3*	50	-40 to +150		0.45	2.0	0.2	70	150	20	0.072
	3.0	Surface-Mount (SJP)	SJPJ-L3	60	-40 to +150		0.45	3.0	0.3	150	150	20	0.072

*Under development

●Thru-Hole

V _{RM} (V)	I _F (AV) (A)	Package Axial (Body Diameter/Lead Diameter)	Part Number	I _{FSM} (A)	T _j (°C)	T _{stg} (°C)	V _F (V) max	I _F (A)	I _R (mA)	I _{R(H)} (mA)	T _j (°C)	R _{th(j-l)} R _{th(j-c)} (°C/W)	Mass (g)
				50Hz Single Half Sine Wave					V _R =V _{RM} max	V _R =V _{RM} max			
30	3.0	Axial(φ6.5/φ1.4)	RJ 43	50	-40 to +150		0.45	3.0	3.0	100	150	8.0	1.2
	10	TO-220F(Center-tap)	FMJ-23L	100	-40 to +150		0.45	5.0	5.0	175	150	4.0	2.1
	30	TO-220F(Center-tap)	FMJ-2303	150	-40 to +150		0.48	15	15	500	150	4.0	2.1

4-5 Power Zener Diodes

P (W)	VZ 1mA (V)	PR (W)	Package	Part Number	VDC (V)	I _{ZSM} (A)	Conditions	T _j T _{stg} (°C)	IR (μA) max	Mass(g)
1	28±3	50 (5ms)	Surface-Mount(SJP)	SJPZ-K28	20	2	5ms rectangular wave	-55 to +150	10	0.07
1	18.8 to 21.2	95 (500 μs)	Surface-Mount(SJP)	SJPZ-E20	15	–	–	-55 to +150	10	0.07
1	31.0 to 35.0		Surface-Mount(SJP)	SJPZ-E33	25	–	–	-55 to +150	10	0.07
2	16.8 to 19.1	500 (500 μs)	Surface-Mount(SJP)	SJPZ-N18	13	–	–	-55 to +150	1	0.07
2	25.1 to 28.9		Surface-Mount(SJP)	SJPZ-N27	20	–	–	-55 to +150	1	0.07
2	31.0 to 35.0		Surface-Mount(SJP)	SJPZ-N33	25	–	–	-55 to +150	1	0.07
2	37.8 to 42.2		Surface-Mount(SJP)	SJPZ-N40*	30	–	–	-55 to +150	1	0.07
5	24 to 30	–	Surface-Mount(SZ-10)	SZ-10N27	22	70	Fig.1	-55 to +175	10	2.55
5	36 to 44	–	Surface-Mount(SZ-10)	SZ-10N40*	22	40	Fig.1	-55 to +175	10	2.55
6	24 to 30	–	Surface-Mount(SZ-10)	SZ-10NN27	22	90	Fig.1	-55 to +175	10	2.55
6	36 to 44	–	Surface-Mount(SZ-10)	SZ-10NN40	22	55	Fig.1	-55 to +175	10	2.55

*Under development

Figure1

I_{ZSM} Condition



4-6 Silicon Varistors

●Symmetrical

V _F (V)	I _F (mA)	Part Number	I _F (μ A) max	V _F (V)	I _{rsm} (A)	T _j (°C)	T _{stg} (°C)	R _{th(j-l)} (°C/W)	Mass (g)	Package
					50Hz Single Half Sine Wave					
1.5max	1000	VR-60SS	20	0.2	15	-40 to +100		20	0.3	Axial(ϕ 2.7/ ϕ 0.6)
2.3 \pm 0.25	1	VR-61SS			7.5	-40 to +100		20	0.3	Axial(ϕ 2.7/ ϕ 0.6)
2.75 \pm 0.25	10									
3.1 \pm 0.25	70									
2.0max	100	SV-3SS	50	0.6		-40 to +100		20	0.3	Axial(ϕ 2.7/ ϕ 0.6)
1.8 \pm 0.2	1	SV-4SS	50	0.9		-40 to +100		20	0.3	Axial(ϕ 2.7/ ϕ 0.6)
2.15 \pm 0.2	10									
2.4 \pm 0.25	30									

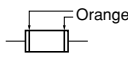
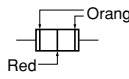
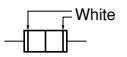
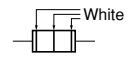
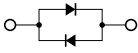
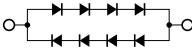
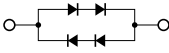
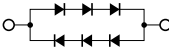
Part Number	VR-60SS	VR-61SS	SV-3SS	SV-4SS
Display Color				
Internal Connection				

Package Type (Dimensions)

• No. 1 Surface-Mount (SJP)

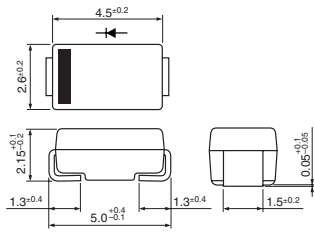

• No. 2 Surface-Mount (TO263)

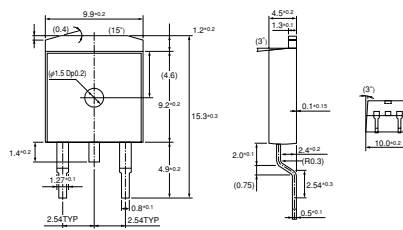

• No. 3 Surface-Mount (TO220S)
MPL-102S, MP2-202S, MPL-1036

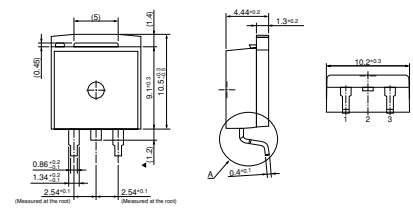

• No. 4 Surface-Mount (TO220S)

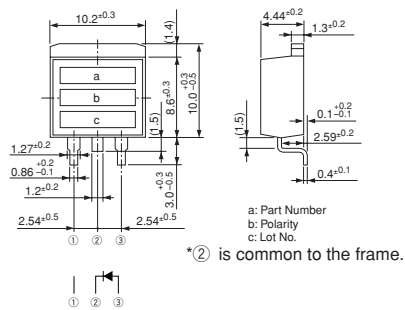

• No. 5 Surface-Mount (TO220S) Center-tap

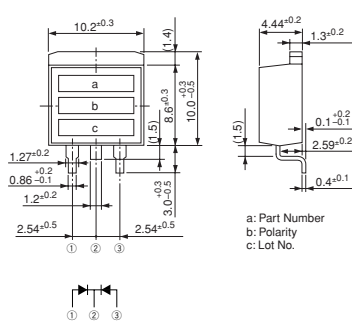

• No. 6 Surface-Mount (SZ-10)

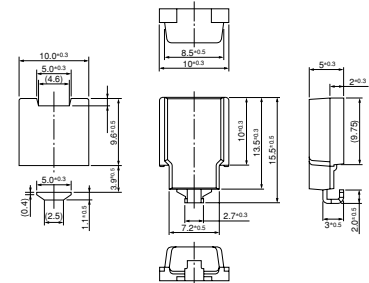

• No. 7 Axial ($\phi 2.4/\phi 0.6$)

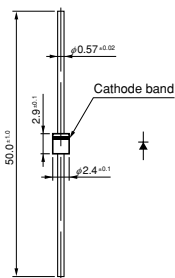

• No. 8 Axial ($\phi 2.7/\phi 0.6$)

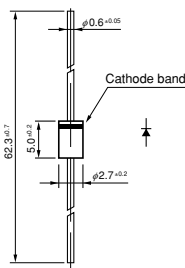

• No. 9 Axial ($\phi 2.7/\phi 0.6$)
Silicon Varistors (Symmetrical)

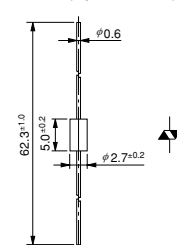

• No. 10 Axial ($\phi 2.7/\phi 0.78$)

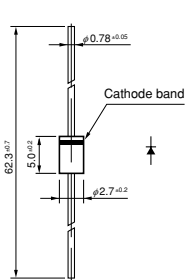

• No. 11 Axial ($\phi 4.0/\phi 0.78$)

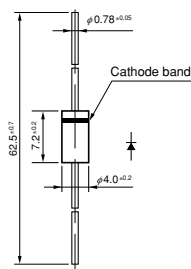

• No. 12 Axial ($\phi 4.0/\phi 0.98$)

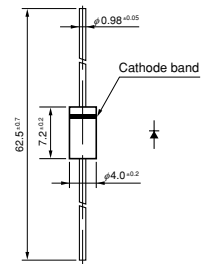

• No. 13 Axial ($\phi 6.5/\phi 1.4$)

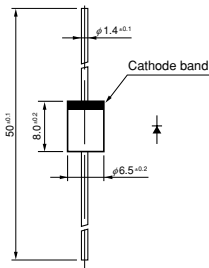

• No. 14 TO-220F (Two Elements)

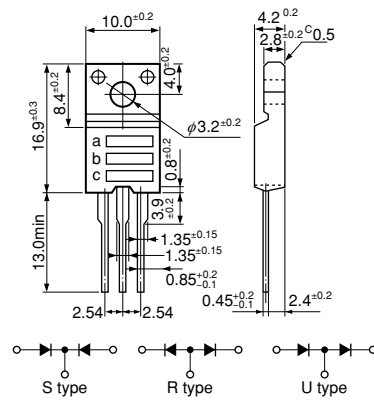

a: Part Number
b: Polarity
c: Lot No.

• No. 15 TO-220F (Center-tap)

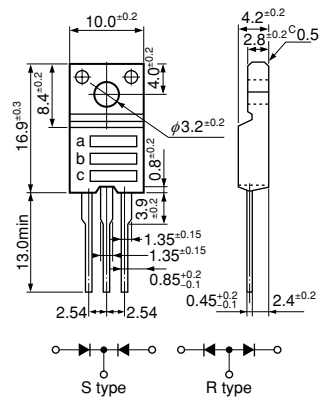

a: Part Number
b: Polarity
c: Lot No.

• No. 16 TO-220F2Pin

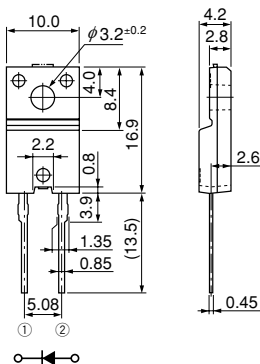

• No. 17 TO-220F2Pin (Two Elements)

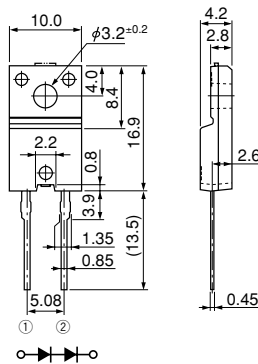

• No. 18 TO-3PF

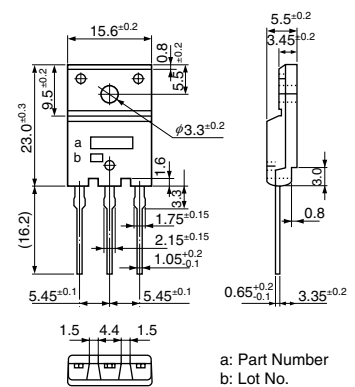

a: Part Number
b: Lot No.

• No. 19 TO-3PF2Pin

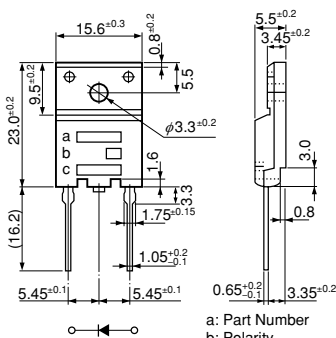

a: Part Number
b: Polarity
c: Lot No.

DC/DC Power Modules



Ordering Information	222
Selection Guide	222
Application Note	223
DC/DC Power Modules	224



Ordering Information

All products listed must be ordered in standard packing increments.

Product Name	Package	Standard Packing Quantities (Bulk)	Standard Packing Quantities (Taping)
MPM01	ZIP 9	50	–
MPM04	ZIP 9	50	–
BR200	Board surface-mount type	42	–
BR201	Board surface-mount type	42	–
BR202	Board surface-mount type	30	–
BR203	Board surface-mount type	30	–
BR204	Board surface-mount type	42	–
BR205	Board surface-mount type	42	–
BR206	Board surface-mount type	30	–
BR300	Board lead type	50	–
BR301	Board lead type	50	–

Selection Guide

Mold type

Part Number	Package	Size (L×W×H)	Input Voltage	Output Voltage	Output Current	Oscillation Frequency	Remarks	Page
		[mm]	[V]	[V]	[A]	[kHz]		
MPM01	ZIP9	24×23×5.5	9 to 40	1.8 to 12	3	250		224
MPM04	ZIP9	24×23×5.5	16 to 40	12 to 24	3	250		224

Board Surface-Mount Type

Part Number	Size (L×W)	Height	Input Voltage	Output Voltage	Output Current	Oscillation Frequency	Remarks	Page
	[mm]	[mm]	[V]	[V]	[A]	[kHz]		
BR200	20.32×11.43	4.2	12±10%	0.75 to 1.65	10	300		226
BR201	20.32×11.43	4.2	12±10%	1.60 to 3.63	10	600		
BR202	33.02×13.46	4.2	12±10%	0.75 to 1.65	20	300		228
BR203	33.02×13.46	4.2	12±10%	1.60 to 3.63	20	400		
BR204	20.32×11.43	4.2	12±10%	1.60 to 5.50	10	600		226
BR205	20.32×11.43	4.2	4.5 to 7.0	0.75 to 3.63	10	600		230
BR206	33.02×13.46	4.2	4.5 to 7.0	0.75 to 3.63	20	500		232

Board lead type

Part Number	Size (L×W)	Height	Input Voltage	Output Voltage	Output Current	Oscillation Frequency	Remarks	Page
	[mm]	[mm]	[V]	[V]	[A]	[kHz]		
BR300	14×14	4.2	8 to 30	5.0	1.0	350		234
BR301	14×14	4.2	8 to 30	3.3	1.0	350		

Application Note

<Mold Type>

■ Heat Dissipation and Reliability

Generally, the service life of electronic parts becomes shorter as the temperature increases. Electronic parts can be used without fins, depending on the input and output conditions, but suppressing increases in temperature is the most effective way to enable longer use. The package temperature can be reduced by derating the output current. To get the desired expected service life, implement cooling techniques such as attaching heatsinks or carrying out forced air cooling by using fans. Pay attention to heat dissipation. When mounting the module power supply on the heatsink, make sure to apply silicone grease and attach it securely. Allow sufficient margins in heatsink design. To thoroughly dissipate the heat, consider implementing air convection.

The reliability of input/output capacitors is related to temperature. A high operating temperature may reduce the service life. Only use the capacitors in applications recommended by the capacitor manufacturer.

■ Internal Power Dissipation

P_D can be obtained from the following formula.

$$P_D = P_{in} - P_o \\ = V_{in} \times I_{in} - V_o \times I_o$$

Or, if Efficiency η is known,

$$P_D = P_o \times (\frac{1}{\eta} - 1) - P_o$$

P_D : Internal power dissipation
 P_{in} : Input power
 P_o : Output power
 V_{in} : Input voltage
 I_{in} : Input current
 V_o : Output voltage
 I_o : Output current
 η : Efficiency

■ Thermal Design

The maximum junction temperature $T_{j(max)}$ given in the Absolute Maximum Ratings is specific to each product type and must be strictly observed. Thus, thermal design must consider the maximum power dissipation $P_{D(max)}$, which varies according to the conditions of use, and the maximum ambient temperature $T_{a(max)}$.

To simplify thermal design, T_a - P_D characteristic graphs are provided herein. Please observe the following steps for heatsink design:

1. Obtain the maximum ambient temperature $T_{a(max)}$.
2. Obtain the maximum power dissipation $P_{D(max)}$.
3. Look for the intersection point on the T_a - P_D characteristic graph and determine the size of the heatsink.

Although the heatsink size is now obtained, in actual applications, derating factor of 10-to-20% is generally used. Moreover, the heat dissipation capacity of a heatsink highly depends on how it is mounted. Thus, it is recommended to measure the heatsink and case temperature in the actual operating environment.

For details, refer to the T_a - P_D characteristic graphs for each product type.

■ Mounting Torque

MPM01/04 0.588 to 0.785[N·m]

■ Recommended Silicone Grease

- Shin-Etsu Chemical Co., Ltd.: G746
- Momentive Performance Materials Inc.: YG-6260
- Dow Corning Toray Silicone Co., Ltd.: SC102

Be sure to select proper silicone grease carefully since the oil in some grease products may penetrate the device, resulting in an extremely short device life.

■ Other notes

- Devices cannot be operated connected in parallel in order to obtain a larger current.
- Module power supplies cannot be used for current boosting or voltage step-up applications.

MPM Series Step-down Synchronous Rectifier Type DC/DC Converter Module

■Features

- Switch element, coil, control circuit and peripheral components incorporated in single package
- Fewer external parts: Only 3 components required: Cin, Co, and RFB
- Oscillation frequency: 250kHz
- Synchronous rectifier type
- High efficiency: 91% typ (VIN=33V, Vo=12V, Io=3A)
- Built-in H/S (40mΩ typ.), L/S (26mΩ typ.) ON resistance switching MOSFETs
- Full mold, stand-alone, IC type package: SIP9 (resin dimensions 24×23×5.5mm)

■Applications

- FA equipment, communication equipment
- Consumer equipment, gaming equipment
- Other

■Absolute Maximum Ratings

Parameter	Symbol	Ratings	Unit	Remarks
VIN Pin Voltage	VIN	-0.3 to 41	V	
FB Pin Voltage	VFB	-0.3 to 6	V	
Vo Pin Voltage	Vo	-0.3 to 13	V	MPM01
Vo Pin Voltage	Vo	-0.3 to 28.8	V	MPM04
VIN-SW Voltage	VVIN-SW	55	V	
Junction Temperature*1	Tj	-20 to 150	°C	
Storage Temperature	Tstg	-20 to 120	°C	
Thermal Resistance (Between MIC Junction and Frame)	θj-f	7.7	°C/W	

*1: Limited by thermal protection circuit. The thermal protection detection temperature is approx. 160°C.

■Recommended Operating Conditions

Parameter	Symbol	Ratings		Unit	Conditions
		min.	max.		
Input Voltage Range (MPM01)	VIN	Vo+4*4	40	V	
Input Voltage Range (MPM04)	VIN	Vo+4	40	V	When Vo=12 to 18V
		30	40	V	When Vo=20V
		36	40	V	When Vo=24V
Output Current Range*3	Io	0	3	A	
Operating Junction Temperature	Tjop	-20	125	°C	
Operating Ambient Temperature Range*3	Ta	-20	85	°C	With derating

*2: The recommended operating conditions show the operating conditions required to maintain normal circuit functions as shown in the electrical characteristics.

In actual operation, the device must be used within the recommended operating conditions.

*3: But the device must be used within the derating curve.

*4: The minimum value of the input voltage range is the higher of 9V or Vo+4V.

■Electrical Characteristics

(Ta = 25°C)

Parameter	Symbol	Ratings			Unit	Conditions
		min.	typ.	max.		
Reference Voltage	VFBref	0.490	0.500	0.510	V	VIN=33V, Io=1A
Efficiency*6	η	-	91	-	%	VIN=33V, Vo=12V, Io=3A
Oscillation Frequency	fo	212	250	288	kHz	VIN=33V, Vo=12V, Io=3A
Line Regulation*7	Vline	-	-	±2	%	VIN=16 to 40V, Vo=12V, Io=1A
Load Regulation*7	Vload	-	-	±3	%	VIN=33V, Vo=12V, Io=0 to 3A
Overcurrent Protection Starting Current	Is	3.2	5.60	7.0	A	VIN=33V, Vo=12V, Drooping/Auto restore*8
Circuit Current	Iin	-	12	-	mA	VIN=33V, Io=0A, VFB=1V
MIC Thermal Protection Start Temperature*9	Tj	151	160	-	°C	VIN=16V to 40V
Input Voltage Undervoltage Protection	UVLO	-	7.3	8.0	V	
Startup Delay Time	Tstart	-	50	-	ms	VIN=16 to 40V. Time from VIN application to when Vo reaches constant voltage precision

*5: The electrical characteristics are characteristic values guaranteed when the IC is operated under the measurement conditions shown for each of the items in the table above.

*6: The efficiency is calculated by Formula 1.

$$\eta (\%) = \frac{V_o \times I_o}{V_{IN} \times I_{in}} \times 100 \dots\dots\dots \text{Formula 1}$$

*7: The line/load regulations do not include the setting deviation of the output voltage. The output voltage setting deviation is affected by the precision of the external RFB.

*8: When an output voltage of other than Vo=12V is set, the OCP operation point may fluctuate compared to the point when Vo=12V because the inductance of the built-in coil is constant and the frequency is constant for the specified output voltage.

*9: Auto restore is used for thermal protection.

External Dimensions (ZIP9)

(Unit : mm)

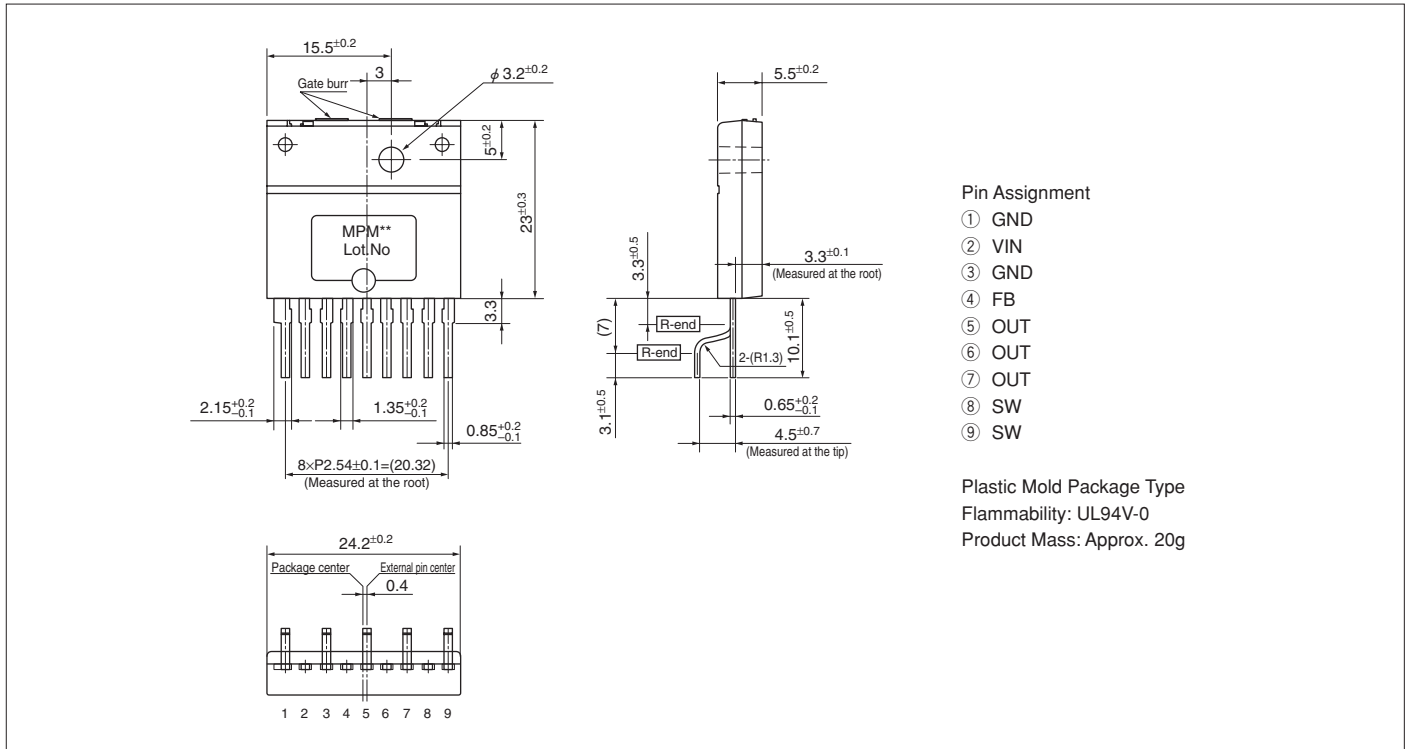

Block Diagram



Typical Connection Diagram



BR200 Series 12V System, For Intermediate Bus, Output 10A Type POL Converter Module

■Features

- Industry standard footprint
- Solderability improved by adopting cut through holes
- Low height: 4.2mm
- High power
- High efficiency
BR200: 89.9%typ. (Vin=12.0V, Vo=1.5V, Io=7A)
BR201: 93.8%typ. (Vin=12.0V, Vo=3.3V, Io=7A)
BR204: 95.5%typ. (Vin=12.0V, Vo=5.0V, Io=7A)
- Downsizing achieved by using high frequency switching technology
External dimensions 20.3mm×11.4mm×4.2mmH

■Applications

- Communication equipment
- Servers
- Other

■Lineup

Product Name	Vo[V]	Io[A]
BR200	0.75 to 1.65	10
BR201	1.60 to 3.63	10
BR204	1.60 to 5.50	10

■Environmental Conditions

Operating Temperature Range	-40 to 85°C	With derating curve
Operating Humidity Range	20 to 85%	Non condensing
Storage Temperature Range	-40 to 85°C	
Storage Humidity Range	10 to 95%	Non condensing

■Absolute Maximum Ratings

(Ta = 25°C, unless otherwise specified)

Pin	Symbol	Ratings	Unit	Remarks
1	ON/OFF	7	V	
9	PG	7	V	
		7	mA	Sink current

■Electrical Characteristics

(Ta = 25°C, unless otherwise specified)

Parameter	Symbol	Ratings			Unit	Remarks	
		min.	typ.	max.			
Input Voltage Range	Vin	10.8	12.0	13.2	V		
Output Voltage	BR200	Vout	0.75	–	1.65	V	Adjusted by Rtrim
	BR201	Vout	1.60	–	3.63	V	Adjusted by Rtrim
	BR204	Vout	1.60	–	5.50	V	Adjusted by Rtrim
Output Current	Io	0	–	10	A	With temperature derating	
Output Voltage Precision	Vo tol	-2.0	–	2.0	%	Vin=10.8 to 13.2V, 0 to Iomax, Operating temperature range, Rtrim=1% precision	
Ripple Voltage	BR200	Vrip	–	–	50	mVp-p	Vout=1.2V* ¹
	BR201		–	–	50		Vout=3.3V* ²
	BR204		–	–	50		Vout=5.0V* ²
Efficiency	BR200	Eff	–	85.5	–	%	Vin=12V, Io=10A, Vo=1.5V
	BR201	Eff	–	93.2	–		Vin=12V, Io=10A, Vo=3.3V
	BR204	Eff	–	95.0	–		Vin=12V, Io=10A, Vo=5.0V
Oscillation Frequency	BR200	frq	–	300	–	kHz	
	BR201		–	600	–		
	BR204		–	600	–		
Overcurrent Protection	OCP	–	24.5	–	A	Hiccup	
Rising Time	BR200	Tr	–	1.5	–	ms	Vo=10 to 90%
	BR201		–	1.0	–		
	BR204		–	0.7	–		

*1: BW=20MHz, Iout=0 to 10A, Cout=400μF

*2: BW=20MHz, Iout=0 to 10A, Cout=100μF

External Dimensions

(Unit : mm)

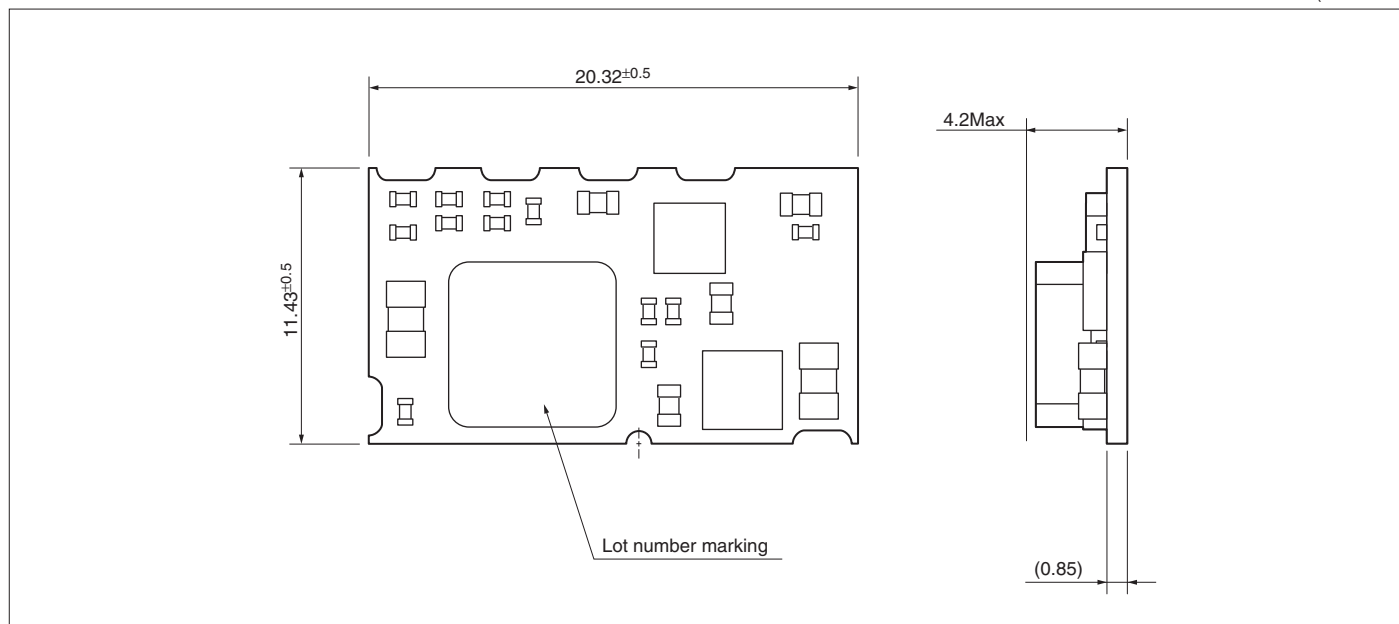

Typical Connection Diagram

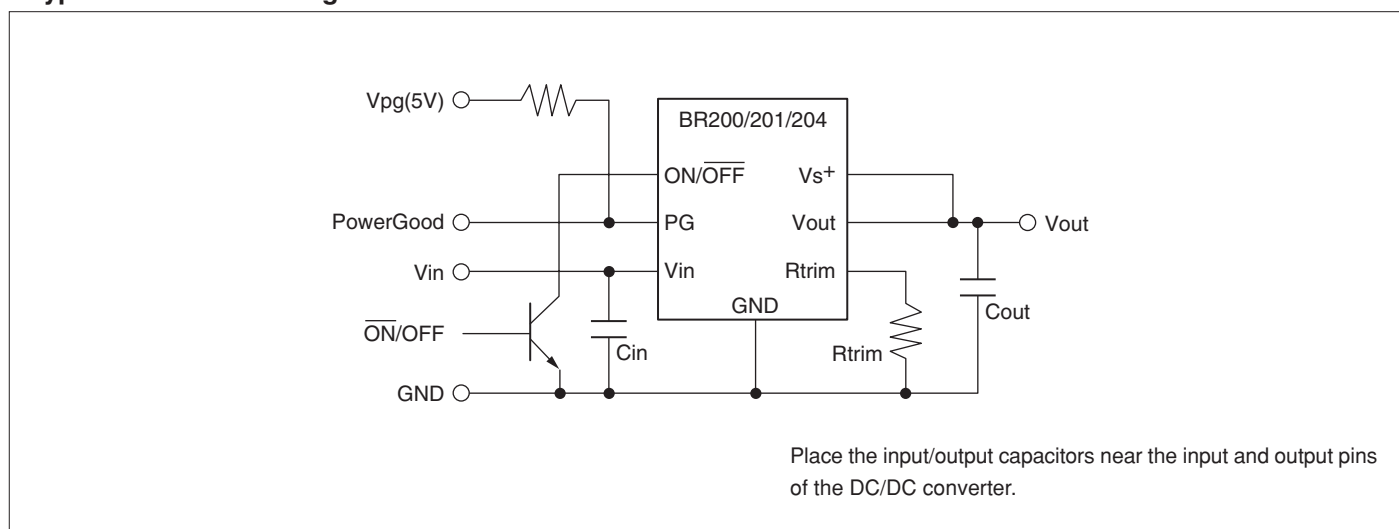

Reference Data

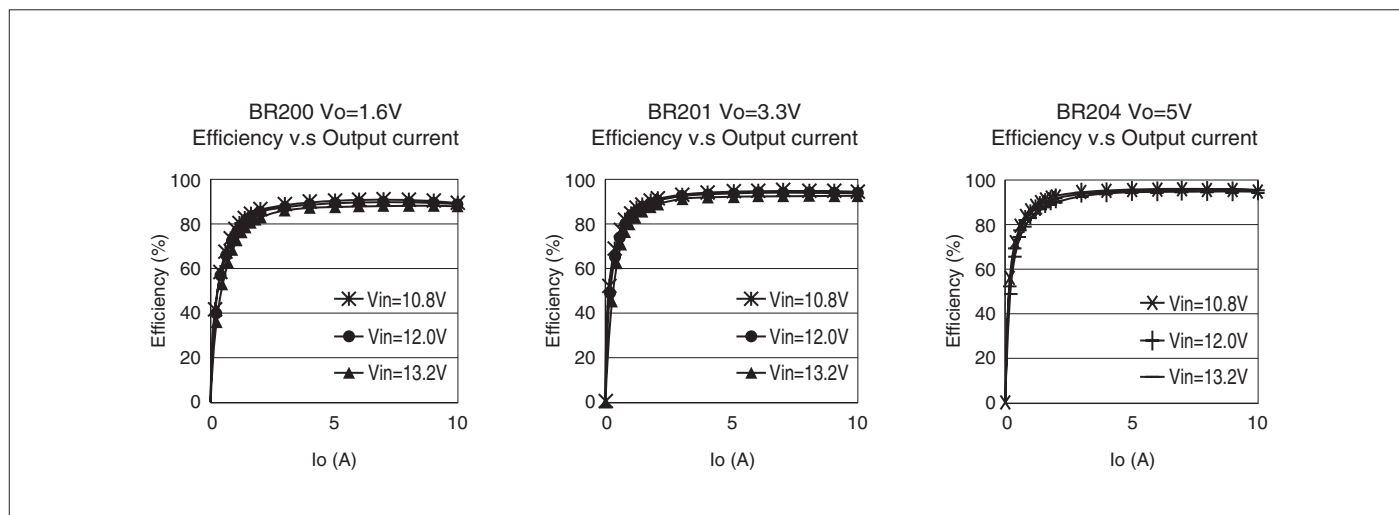

BR200 Series 12V System, For Intermediate Bus, Output 20A Type POL Converter Module

■Features

- Industry standard footprint
- Solderability improved by adopting cut through holes
- Low height: 4.2mm
- High power
- High efficiency
BR202: 88.5%typ. (Vin=12.0V, Vo=1.2V, Io=11A)
BR203: 93.4%typ. (Vin=12.0V, Vo=3.3V, Io=12A)
- Downsizing achieved by using high frequency switching technology
External dimensions 33.02mm×13.46mm×4.2mmH

■Applications

- Communication equipment
- Servers
- Other

■Lineup

Product Name	Vo[V]	Io[A]
BR202	0.75 to 1.65	20
BR203	1.60 to 3.63	20

■Environmental Conditions

Operating Temperature Range	-40 to 85°C	With derating curve
Operating Humidity Range	20 to 85%	Non condensing
Storage Temperature Range	-40 to 85°C	
Storage Humidity Range	10 to 95%	Non condensing

■Absolute Maximum Ratings

(Ta = 25°C, unless otherwise specified)

Pin	Symbol	Ratings	Unit	Remarks
1	ON/OFF	7	V	
9	PG	7	V	
		7	mA	Sink current

■Electrical Characteristics

(Ta = 25°C, unless otherwise specified)

Parameter	Symbol	Ratings			Unit	Remarks	
		min.	typ.	max.			
Input Voltage Range	Vin	10.8	12.0	13.2	V		
Output Voltage	BR202	Vout	0.75	–	1.65	V	Adjusted by Rtrim
	BR203	Vout	1.60	–	3.63	V	Adjusted by Rtrim
Output Current	Io	0	–	20	A	With temperature derating	
Output Voltage Precision	Vo tol	-2.0	–	2.0	%	Vin=10.8 to 13.2V, 0 to Iomax, Operating temperature range, Rtrim=1% precision	
Ripple Voltage	BR202	Vrip	–	15	100	mVp-p	Vout=1.2V*1
	BR203	Vrip	–	25	100		Vout=3.3V*1
Efficiency	BR202	Eff	–	86.1	–	%	Vin=12V, Io=20A, Vo=1.2V
	BR203	Eff	–	92.3	–		Vin=12V, Io=20A, Vo=3.3V
Oscillation Frequency	BR202	frq	–	300	–	kHz	
	BR203	frq	–	400	–		
Overcurrent Protection	OCF	–	30	–	A	Hiccup	
Rising Time	BR202	Tr	–	2.0	–	ms	Vo=10 to 90%
	BR203	Tr	–	1.5	–		

*1: BW=20MHz, Iout=0 to 20A, Cout=400μF

External Dimensions

(Unit : mm)

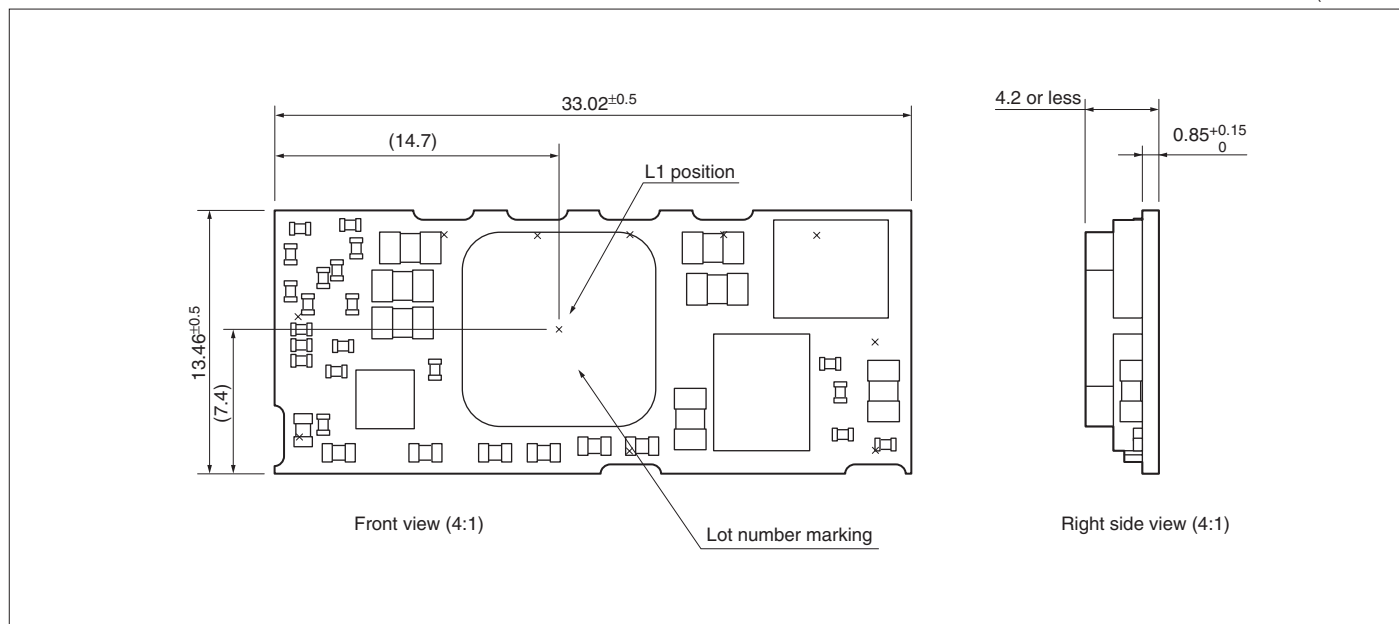

Typical Connection Diagram

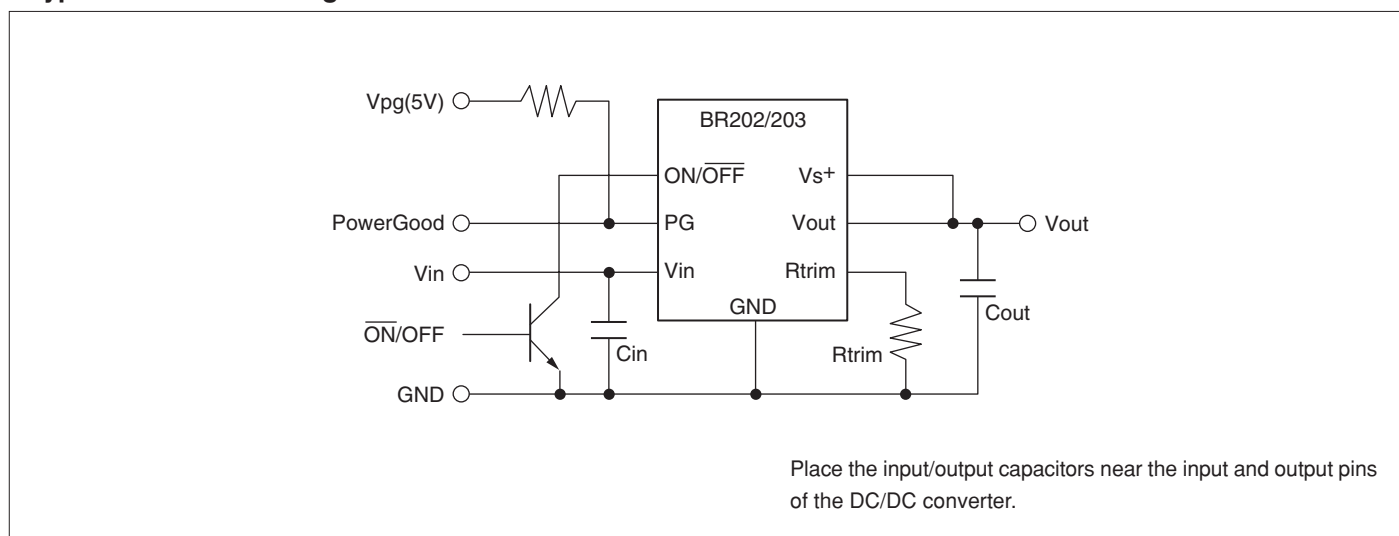

Reference Data

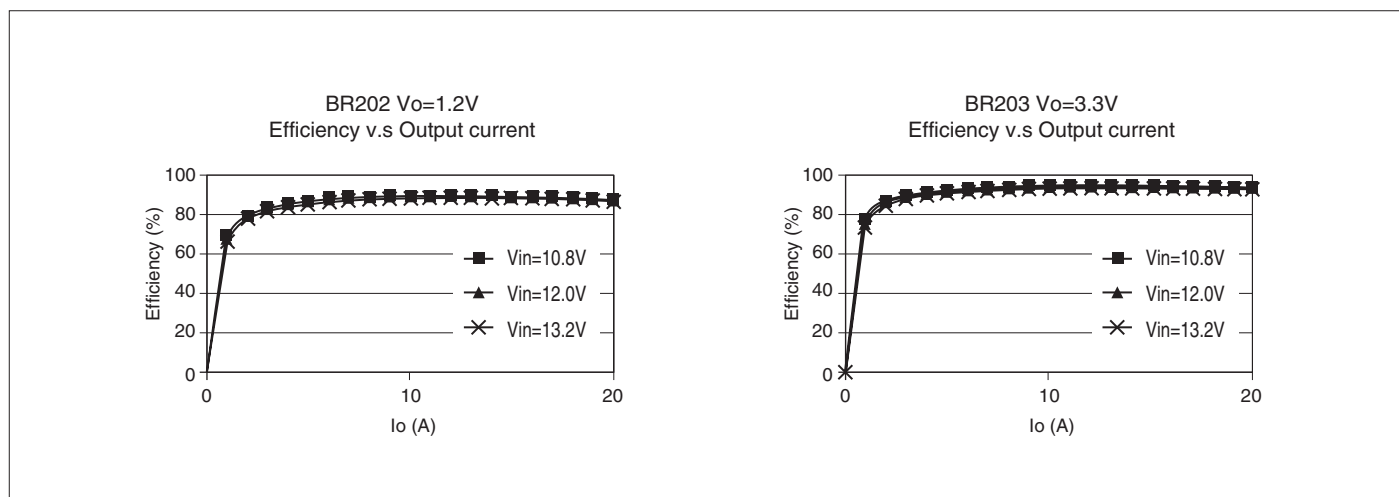

BR200 Series 5V System, For Intermediate Bus, Output 10A Type POL Converter Module

■ Features

- Industry standard footprint
- Solderability improved by adopting cut through holes
- Low height: 4.2mm
- High power
- High efficiency
BR205: 96.4%typ. (Vin=5.0V, Vo=3.3V, Io=5A)
- Downsizing achieved by using high frequency switching technology
External dimensions 20.3mm×11.4mm×4.2mmH

■ Applications

- Communication equipment
- Servers
- Other

■ Lineup

Product Name	Vo[V]	Io[A]
BR205	0.75 to 3.63	10

■ Environmental Conditions

Operating Temperature Range	-40 to 85°C	With derating curve
Operating Humidity Range	20 to 85%	Non condensing
Storage Temperature Range	-40 to 85°C	
Storage Humidity Range	10 to 95%	Non condensing

■ Absolute Maximum Ratings

(Ta = 25°C, unless otherwise specified)

Pin	Symbol	Ratings	Unit	Remarks
1	ON/OFF	7	V	
9	PG	7	V	
		7	mA	Sink current

■ Electrical Characteristics

(Ta = 25°C, unless otherwise specified)

Parameter	Symbol	Ratings			Unit	Remarks
		min.	typ.	max.		
Input Voltage Range	Vin	4.5	5.0	7.0	V	
Output Voltage	Vout	0.75	–	3.63	V	Adjusted by Rtrim
Output Current	Io	0	–	10	A	With temperature derating
Output Voltage Precision	Vo tol	-2.0	–	2.0	%	Vin=4.5 to 7.0V, 0 to Iomax, Operating temperature range, Rtrim=1% precision
Ripple Voltage	Vrip	–	–	50	mVp-p	Vout=1.2V* ¹
Efficiency	Eff	–	94.5	–	%	Vin=5.0V, Io=10A, Vo=3.3V
		–	87.8	–		Vin=5.0V, Io=10A, Vo=1.5V
Oscillation Frequency	frq	–	600	–	kHz	
Overcurrent Protection	OCP	–	24.5	–	A	Hiccup
Rising Time	Tr	–	0.5	–	ms	Vo=10 to 90%

*1: BW=20MHz, Iout=0 to 10A, Cout=400μF

External Dimensions

(Unit : mm)

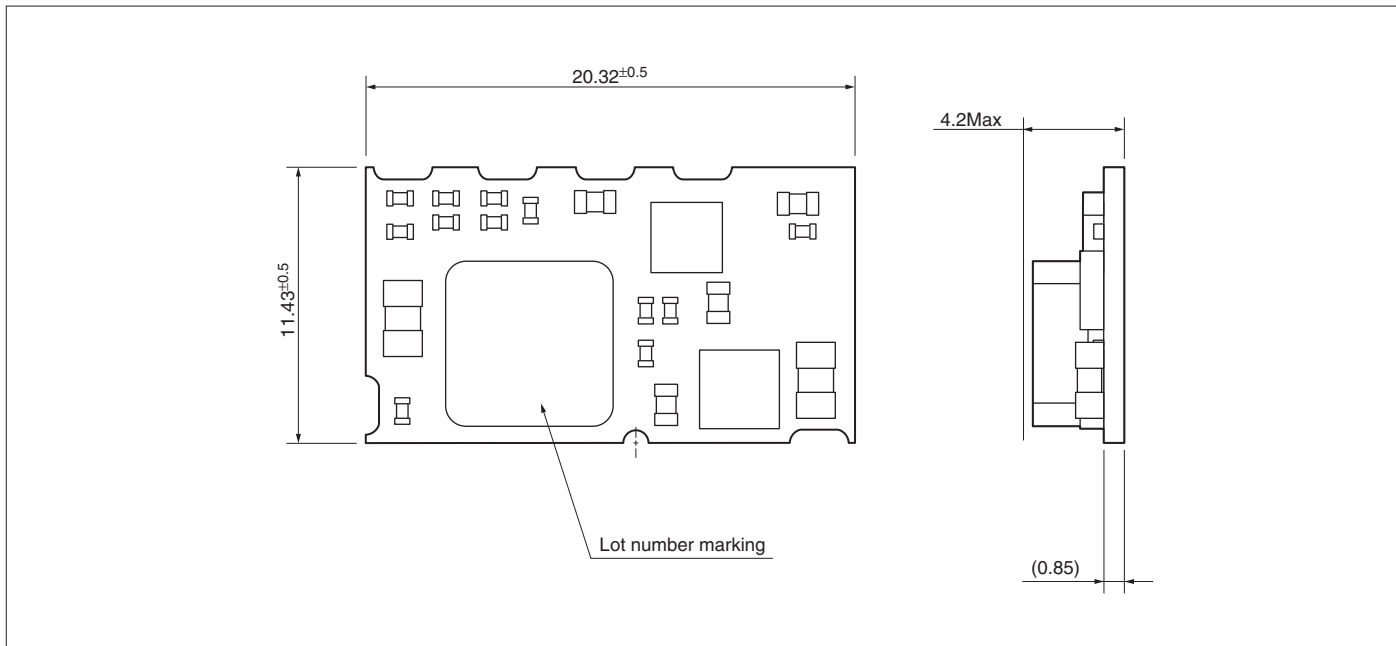

Typical Connection Diagram

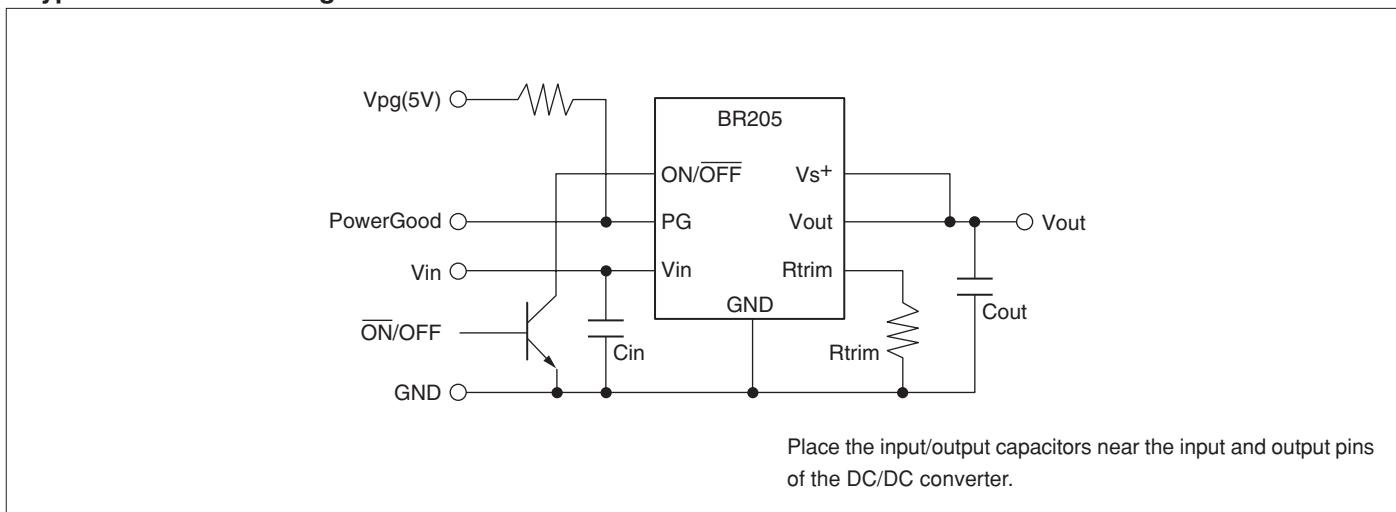

Reference Data

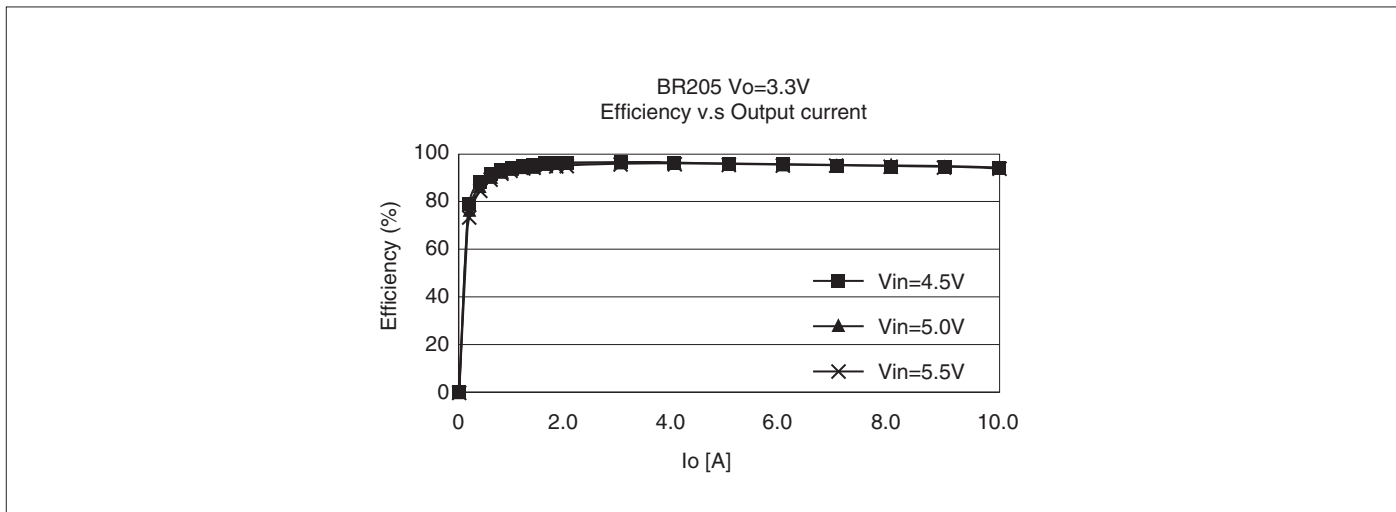

BR200 Series 5V System, For Intermediate Bus, Output 20A Type POL Converter Module

■ Features

- Industry standard footprint
- Solderability improved by adopting cut through holes
- Low height: 4.2mm
- High power
- High efficiency
BR206: 95.2%typ. (Vin=5.0V, Vo=3.3V, Io=14A)
- Downsizing achieved by using high frequency switching technology
External dimensions 30.02mm×13.46mm×4.2mmH

■ Applications

- Communication equipment
- Servers
- Other

■ Lineup

Product Name	Vo[V]	Io[A]
BR206	0.75 to 3.63	20

■ Environmental Conditions

Operating Temperature Range	-40 to 85°C	With derating curve
Operating Humidity Range	20 to 85%	Non condensing
Storage Temperature Range	-40 to 85°C	
Storage Humidity Range	10 to 95%	Non condensing

■ Absolute Maximum Ratings

(Ta = 25°C, unless otherwise specified)

Pin	Symbol	Ratings	Unit	Remarks
1	ON/OFF	7	V	
9	PG	7	V	
		7	mA	Sink current

■ Electrical Characteristics

(Ta = 25°C, unless otherwise specified)

Parameter	Symbol	Ratings			Unit	Remarks
		min.	typ.	max.		
Input Voltage Range	Vin	4.5	5.0	7.0	V	
Output Voltage	Vout	0.75	–	3.63	V	Adjusted by Rtrim
Output Current	Io	0	–	20	A	With temperature derating
Output Voltage Precision	Vo tol	-2.0	–	2.0	%	Vin=4.5 to 7.0V, 0 to Iomax, Operating temperature range, Rtrim=1% precision, Vo=1.5V or less
Ripple Voltage	Vrip	–	–	50	mVp-p	Vout=1.2V*1
Efficiency	Eff	–	93.7	–	%	Vin=5.0V, Io=20A, Vo=3.3V
		–	85.9	–		Vin=5.0V, Io=20A, Vo=1.2V
Oscillation Frequency	frq	–	400	–	kHz	
Overcurrent Protection	OCP	–	30	–	A	Hiccup
Rising Time	Tr	–	2.0	–	ms	Vo=10 to 90%

*1: BW=20MHz, Iout=0 to 20A, Cout=400μF

External Dimensions

(Unit : mm)

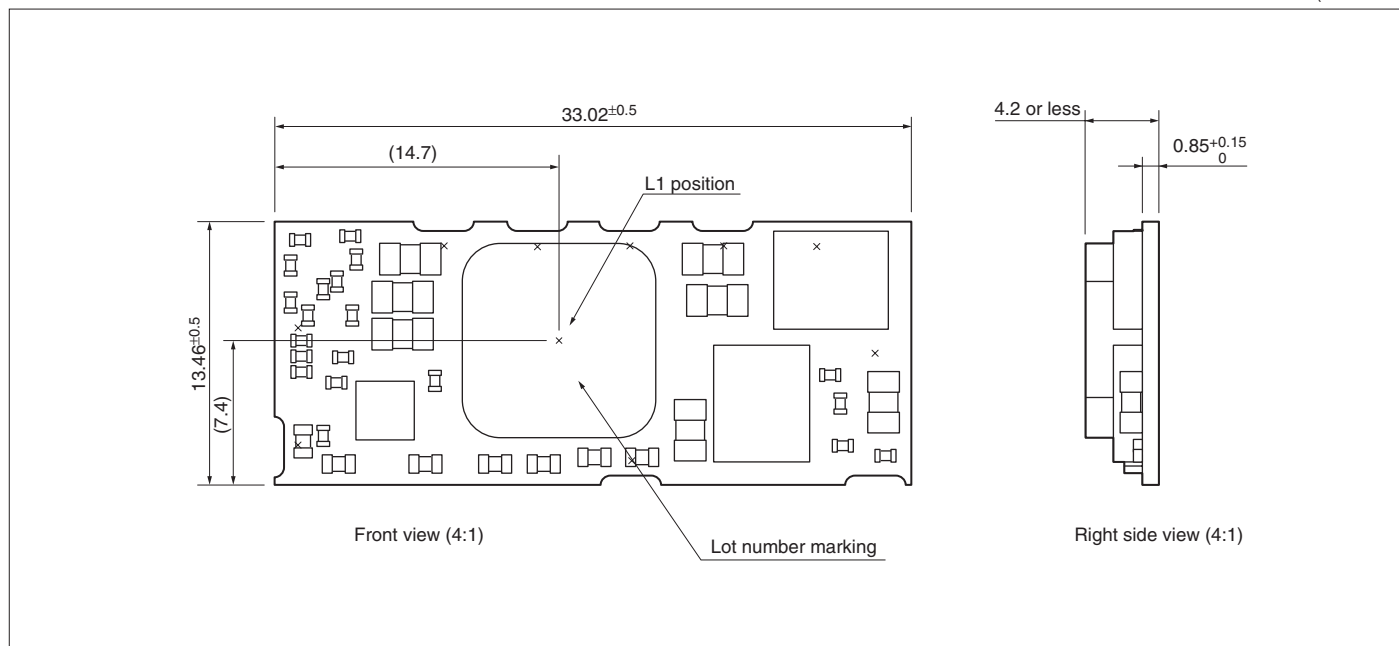

Typical Connection Diagram

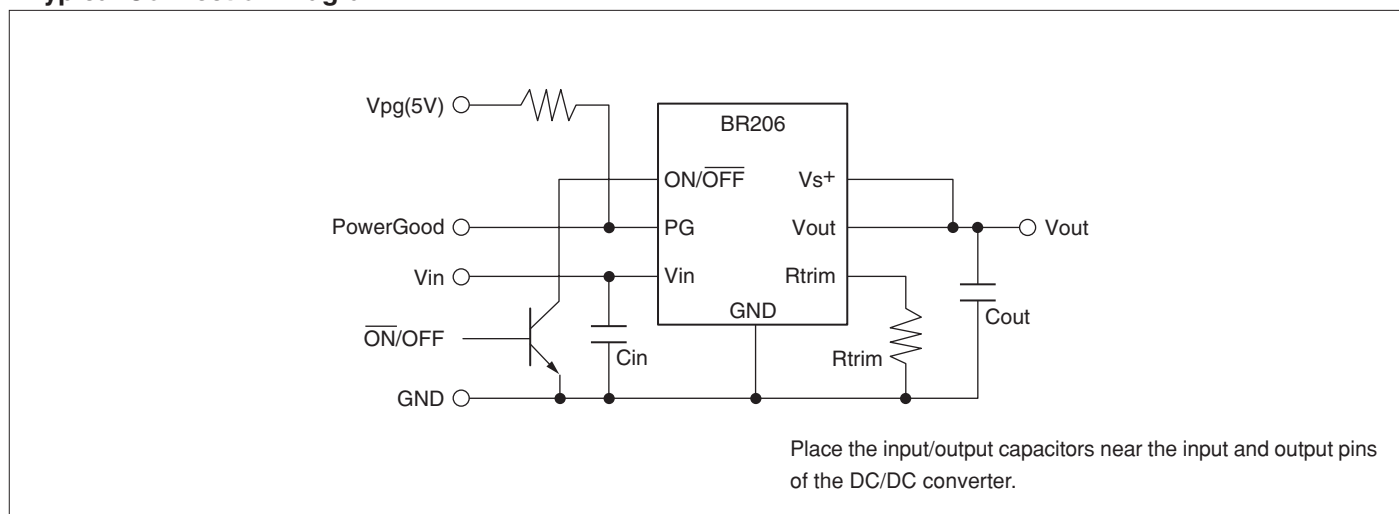

Reference Data

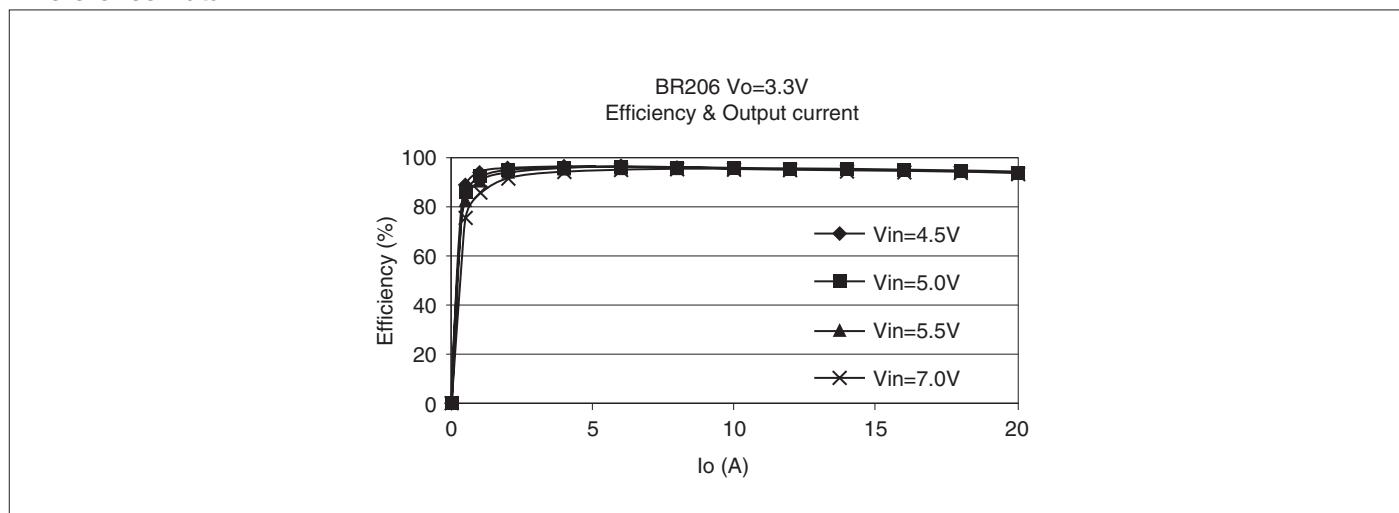

BR300 Series 5V/3.3V 1A Non-Isolated Step-down DC/DC Converter Module

■Features

- Output 5V 1A 5W / 3.3V 1A 3.3W
- External dimensions 14mm×14mm×10mm (W×D×H)
- Weight 1.6g
- All-in-one
- Free design
- High efficiency
BR300: 91%typ. (Vin=8V, Io=0.6A)
BR301: 87%typ. (Vin=8V, Io=0.6A)
- Downsizing achieved by using high frequency switching technology
- Protection functions
Overcurrent Protection
Thermal protection

■Applications

- FA equipment
- Communication equipment
- Consumer equipment
- Other

■Lineup

Product Name	Vo[V]	Io[A]
BR300	5.0	1.0
BR301	3.3	1.0

■Environmental Conditions

Operating Temperature Range	-20 to 85°C	With derating curve
Operating Humidity Range	10 to 90%	Non condensing
Storage Temperature Range	-25 to 85°C	
Storage Humidity Range	5 to 95%	Non condensing

■Absolute Maximum Ratings

(Ta = 25°C, unless otherwise specified)

Parameter	Pin	Symbol	Ratings	Unit	Remarks
Input Voltage	4-2	V _{IN}	-0.3 to +35	V	

■Recommended Operating Conditions

(Ta = 25°C, unless otherwise specified)

Parameter	Pin	Symbol	Ratings		Unit	Remarks
			min.	max.		
Input Voltage Range	4-2	V _{IN}	8	30	V	
Output Current Range	1-2	I _o	0	1	A	

■Electrical Characteristics

(Ta = 25°C, unless otherwise specified)

Parameter	Pin	Symbol	Ratings						Unit	Remarks
			BR300			BR301				
			min.	typ.	max.	min.	typ.	max.		
Input Current	4-2	I _{IN}	-	0.24	-	-	0.17	-	A	V _{IN} =24V, I _o =1A
Standby Power	4-2	P _{STB}	-	0.16	-	-	0.13	-	W	V _{IN} =24V, I _o =0A
Output Voltage	1-2	V _O	-	5.0	-	-	3.3	-	V	
Constant Voltage Precision	1-2	V _{ACC}	-3	-	3	-3	-	3	%	
Output Current	1-2	I _o	0	-	1	0	-	1	A	
Maximum Output Power	1-2	P _{O(MAX)}	-	-	5	-	-	3.3	W	
Output Ripple	1-2	V _{RIP}	-	50	-	-	50	-	mV _{P-P}	V _{IN} =24V, I _o =1A
Output Noise	1-2	V _{NOISE}	-	50	-	-	50	-	mV _{P-P}	V _{IN} =24V, I _o =1A
Output Overcurrent Protection	1-2	I _{OCP}	1.1	-	-	1.1	-	-	A	

External Dimensions

(Unit : mm)

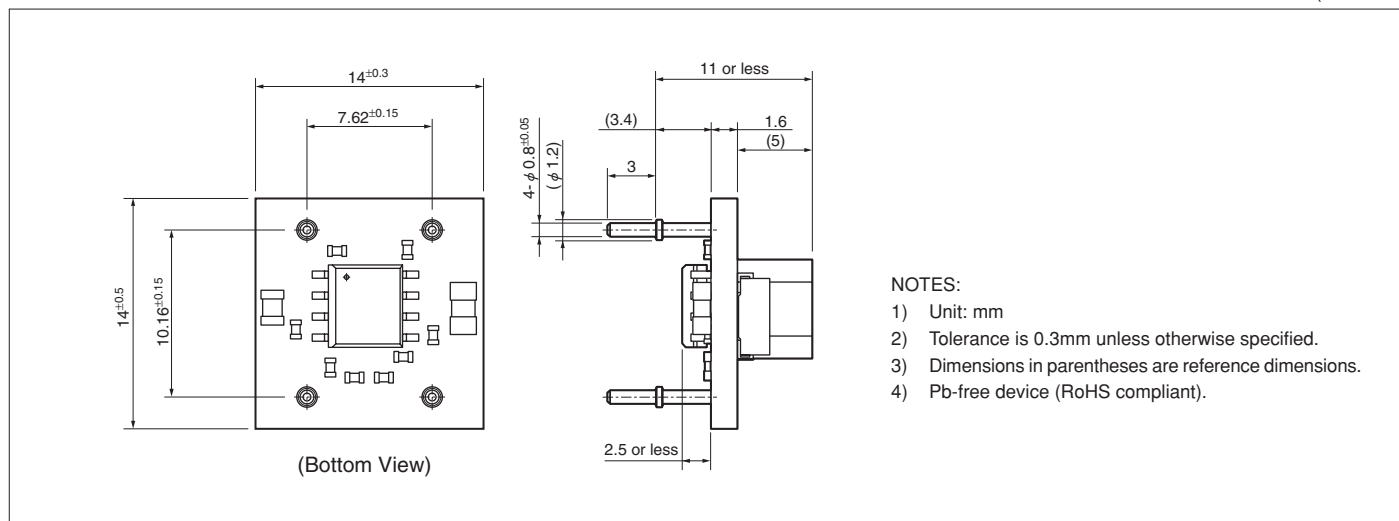

Typical Connection Diagram



Block Diagram

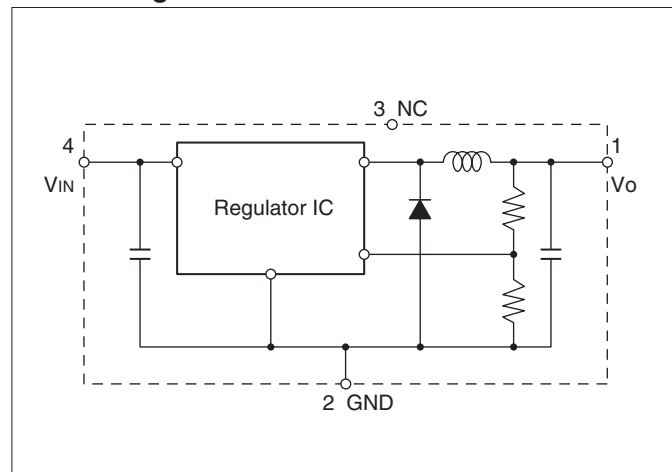

Reference Data

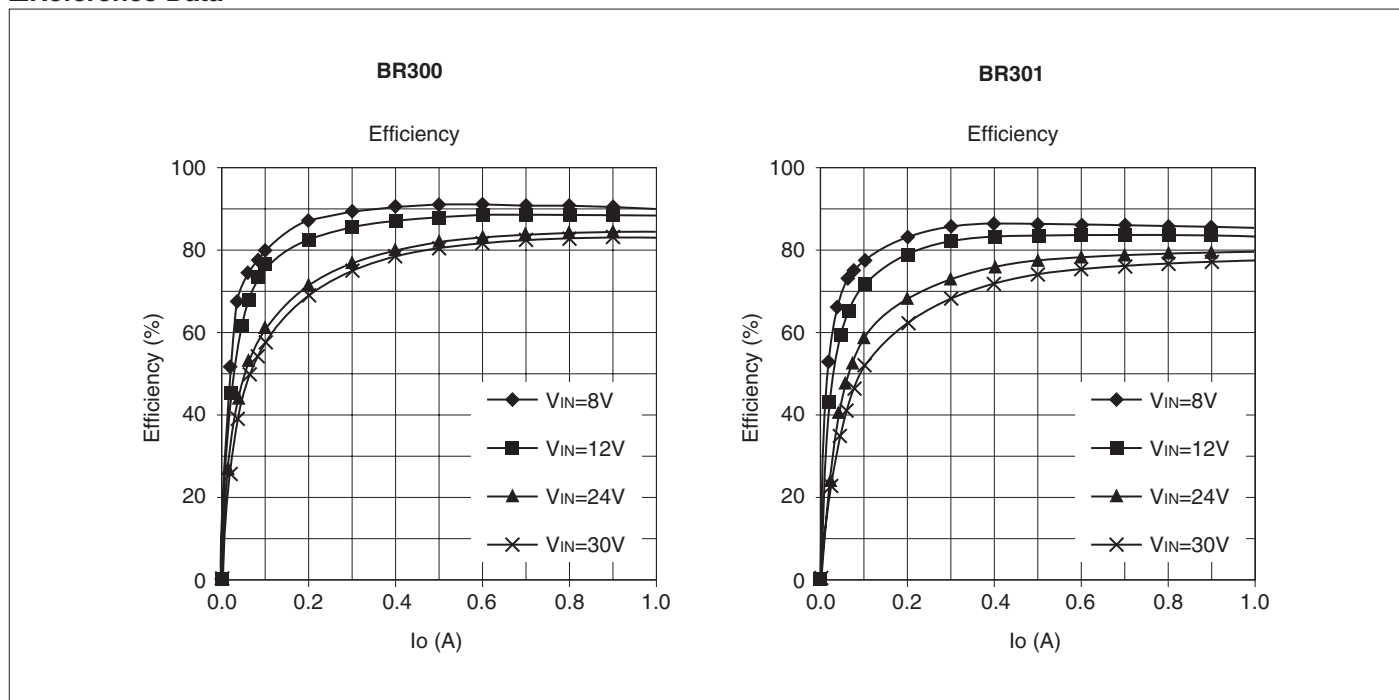

Part Number Index

Part No.	Category	Description	Page
2SA1186	Transistor	Audio and General Purpose (LAPT)	160
2SA1215	Transistor	Audio and General Purpose (LAPT)	160
2SA1216	Transistor	Audio and General Purpose (LAPT)	160
2SA1294	Transistor	Audio and General Purpose (LAPT)	160
2SA1295	Transistor	Audio and General Purpose (LAPT)	160
2SA1303	Transistor	Audio and General Purpose (LAPT)	160
2SA1386	Transistor	Audio and General Purpose (LAPT)	160
2SA1386A	Transistor	Audio and General Purpose (LAPT)	160
2SA1488	Transistor	General Purpose	160
2SA1488A	Transistor	General Purpose	160
2SA1492	Transistor	Audio and General Purpose (Single Emitter)	160
2SA1493	Transistor	Audio and General Purpose (Single Emitter)	160
2SA1494	Transistor	Audio and General Purpose (Single Emitter)	160
2SA1567	Transistor	General Purpose (Low VCE (sat))	160
2SA1568	Transistor	General Purpose (Low VCE (sat))	160
2SA1667	Transistor	Audio Driver and General Purpose	160
2SA1668	Transistor	Audio Driver and General Purpose	160
2SA1673	Transistor	Audio and General Purpose (Single Emitter)	160
2SA1693	Transistor	Audio and General Purpose (Single Emitter)	160
2SA1694	Transistor	Audio and General Purpose (Single Emitter)	160
2SA1695	Transistor	Audio and General Purpose (Single Emitter)	160
2SA1725	Transistor	Audio and General Purpose (Single Emitter)	160
2SA1746	Transistor	General Purpose	160
2SA1859	Transistor	Audio Driver and General Purpose	160
2SA1859A	Transistor	Audio Driver and General Purpose	160
2SA1860	Transistor	Audio and General Purpose (LAPT)	160
2SA1907	Transistor	Audio and General Purpose (Single Emitter)	160
2SA1908	Transistor	Audio and General Purpose (Single Emitter)	160
2SA1909	Transistor	Audio and General Purpose (Single Emitter)	160
2SA2151	Transistor	Audio and General Purpose (Single Emitter)	160
2SA2151A	Transistor	Audio and General Purpose (Single Emitter)	160
2SA2223	Transistor	Audio and General Purpose (Single Emitter)	160
2SB1257	Transistor	General Purpose (Darlington)	160
2SB1258	Transistor	General Purpose (Darlington)	160
2SB1259	Transistor	General Purpose (Darlington)	160
2SB1351	Transistor	General Purpose (Darlington)	160
2SB1382	Transistor	General Purpose (Darlington)	160
2SB1383	Transistor	General Purpose (Darlington)	160
2SB1420	Transistor	General Purpose (Darlington)	160
2SB1559	Transistor	Audio and General Purpose (Darlington)	160
2SB1560	Transistor	Audio and General Purpose (Darlington)	160
2SB1570	Transistor	Audio and General Purpose (Darlington)	160
2SB1587	Transistor	Audio and General Purpose (Darlington)	160
2SB1588	Transistor	Audio and General Purpose (Darlington)	160
2SB1647	Transistor	Audio and General Purpose (Darlington)	160
2SB1648	Transistor	Audio and General Purpose (Darlington)	160
2SB1649	Transistor	Audio and General Purpose (Darlington)	160
2SC2837	Transistor	Audio and General Purpose (LAPT)	162
2SC2921	Transistor	Audio and General Purpose (LAPT)	162
2SC2922	Transistor	Audio and General Purpose (LAPT)	162
2SC3263	Transistor	Audio and General Purpose (LAPT)	162
2SC3264	Transistor	Audio and General Purpose (LAPT)	162
2SC3284	Transistor	Audio and General Purpose (LAPT)	162
2SC3519	Transistor	Audio and General Purpose (LAPT)	162
2SC3519A	Transistor	Audio and General Purpose (LAPT)	162
2SC3835	Transistor	DC-DC Converter and General Purpose	162
2SC3851	Transistor	General Purpose	162
2SC3851A	Transistor	General Purpose	162
2SC3852	Transistor	General Purpose (High hFE, Low VCE (sat))	162
2SC3852A	Transistor	General Purpose (High hFE, Low VCE (sat))	162
2SC3856	Transistor	Audio and General Purpose (Single Emitter)	162
2SC3857	Transistor	Audio and General Purpose (Single Emitter)	162
2SC3858	Transistor	Audio and General Purpose (Single Emitter)	162
2SC3927	Transistor	SMPS for 200VAC system and General Purpose	162

Part No.	Category	Description	Page
2SC4024	Transistor	DC-DC Converter and General Purpose	162
2SC4131	Transistor	DC-DC Converter and General Purpose	162
2SC4138	Transistor	SMPS for 100VAC system and General Purpose	162
2SC4140	Transistor	SMPS for 100VAC system and General Purpose	162
2SC4153	Transistor	DC-DC Converter and General Purpose	162
2SC4300	Transistor	SMPS for 200VAC system and General Purpose	162
2SC4301	Transistor	SMPS for 200VAC system and General Purpose	162
2SC4304	Transistor	SMPS for 200VAC system and General Purpose	162
2SC4381	Transistor	Audio Driver and General Purpose	162
2SC4382	Transistor	Audio Driver and General Purpose	162
2SC4388	Transistor	Audio and General Purpose (Single Emitter)	162
2SC4445	Transistor	SMPS for 200VAC system and General Purpose	162
2SC4466	Transistor	Audio and General Purpose (Single Emitter)	162
2SC4467	Transistor	Audio and General Purpose (Single Emitter)	162
2SC4468	Transistor	Audio and General Purpose (Single Emitter)	162
2SC4495	Transistor	Audio Temperature Compensation and General Purpose	162
2SC4511	Transistor	Audio and General Purpose (Single Emitter)	162
2SC4518	Transistor	SMPS for 200VAC system and General Purpose	162
2SC4518A	Transistor	SMPS for 200VAC system and General Purpose	162
2SC4546	Transistor	SMPS for 100VAC system and General Purpose	162
2SC4706	Transistor	SMPS for 200VAC system and General Purpose	162
2SC4883	Transistor	Audio Driver and General Purpose	162
2SC4883A	Transistor	Audio Driver and General Purpose	162
2SC4886	Transistor	Audio and General Purpose (LAPT)	162
2SC5071	Transistor	SMPS for 100VAC system and General Purpose	162
2SC5099	Transistor	Audio and General Purpose (Single Emitter)	162
2SC5100	Transistor	Audio and General Purpose (Single Emitter)	162
2SC5101	Transistor	Audio and General Purpose (Single Emitter)	162
2SC5130	Transistor	SMPS for 100VAC system and General Purpose	162
2SC5287	Transistor	SMPS for 100VAC system and General Purpose	162
2SC6011	Transistor	Audio and General Purpose (Single Emitter)	162
2SC6011A	Transistor	Audio and General Purpose (Single Emitter)	162
2SC6145	Transistor	Audio and General Purpose (Single Emitter)	162
2SD1785	Transistor	General Purpose (Darlington)	164
2SD1796	Transistor	General Purpose (Darlington)	164
2SD2014	Transistor	General Purpose (Darlington)	164
2SD2015	Transistor	General Purpose (Darlington)	164
2SD2016	Transistor	General Purpose (Darlington)	164
2SD2017	Transistor	General Purpose (Darlington)	164
2SD2045	Transistor	General Purpose (Darlington)	164
2SD2081	Transistor	General Purpose (Darlington)	164
2SD2082	Transistor	General Purpose (Darlington)	164
2SD2083	Transistor	General Purpose (Darlington)	164
2SD2141	Transistor	General Purpose (Darlington)	164
2SD2389	Transistor	Audio and General Purpose (Darlington)	164
2SD2390	Transistor	Audio and General Purpose (Darlington)	164
2SD2401	Transistor	Audio and General Purpose (Darlington)	164
2SD2438	Transistor	Audio and General Purpose (Darlington)	164
2SD2439	Transistor	Audio and General Purpose (Darlington)	164
2SD2560	Transistor	Audio and General Purpose (Darlington)	164
2SD2561	Transistor	Audio and General Purpose (Darlington)	164
2SD2562	Transistor	Audio and General Purpose (Darlington)	164
2SD2641	Transistor	General Purpose (Darlington)	164
2SD2642	Transistor	General Purpose (Darlington)	164
2SD2643	Transistor	General Purpose (Darlington)	164
2SK2420	Transistor	MOS FET	168
2SK2701A	Transistor	MOS FET	168
2SK2803	Transistor	MOS FET	168
2SK2848	Transistor	MOS FET	168
2SK2943	Transistor	MOS FET	168
2SK3003	Transistor	MOS FET	168
2SK3004	Transistor	MOS FET	168
2SK3199	Transistor	MOS FET	168
2SK3710	Transistor	MOS FET	168

Part No.	Category	Description	Page	Part No.	Category	Description	Page
2SK3711	Transistor	MOS FET	168	EN01Z	Diode	Ultrafast Recovery Diode (Axial)	210
2SK3800	Transistor	MOS FET	168	EP01C	Diode	Ultrafast Recovery Diode (Axial)	212
2SK3801	Transistor	MOS FET	168	ES01A	Diode	Fast Recovery Diode (Axial)	208
AB01B	Diode	Ultrafast Recovery Diode (Axial)	212	ES01F	Diode	Fast Recovery Diode (Axial)	209
AG01	Diode	Ultrafast Recovery Diode (Axial)	211	ES1	Diode	Fast Recovery Diode (Axial)	208
AG01A	Diode	Ultrafast Recovery Diode (Axial)	211	ES1F	Diode	Fast Recovery Diode (Axial)	209
AK04	Diode	Schottky Barrier Diode (Axial)	213	ES1Z	Diode	Fast Recovery Diode (Axial)	208
AK06	Diode	Schottky Barrier Diode (Axial)	214	EU01	Diode	Fast Recovery Diode (Axial)	208
AK09	Diode	Schottky Barrier Diode (Axial)	214	EU01Z	Diode	Fast Recovery Diode (Axial)	208
AL01	Diode	Ultrafast Recovery Diode (Axial)	211	EU02	Diode	Fast Recovery Diode (Axial)	208
AL01Z	Diode	Ultrafast Recovery Diode (Axial)	210	EU02A	Diode	Fast Recovery Diode (Axial)	208
AM01	Diode	Rectifier Diode (Axial)	207	EU02Z	Diode	Fast Recovery Diode (Axial)	208
AM01A	Diode	Rectifier Diode (Axial)	207	EU1	Diode	Fast Recovery Diode (Axial)	208
AM01Z	Diode	Rectifier Diode (Axial)	207	EU1Z	Diode	Fast Recovery Diode (Axial)	208
AP01C	Diode	Ultrafast Recovery Diode (Axial)	212	EU2	Diode	Fast Recovery Diode (Axial)	208
AS01	Diode	Fast Recovery Diode (Axial)	208	EU2A	Diode	Fast Recovery Diode (Axial)	208
AS01A	Diode	Fast Recovery Diode (Axial)	208	EU2Z	Diode	Fast Recovery Diode (Axial)	208
AU01	Diode	Fast Recovery Diode (Axial)	208	FGM603	Transistor	IGBT	172
AU01A	Diode	Fast Recovery Diode (Axial)	208	FGM622S	Transistor	IGBT	172
AU01Z	Diode	Fast Recovery Diode (Axial)	208	FGM623S	Transistor	IGBT	172
AU02	Diode	Fast Recovery Diode (Axial)	208	FKG1020	Transistor	MOS FET	168
AU02A	Diode	Fast Recovery Diode (Axial)	208	FKH0470	Transistor	MOS FET	168
AU02Z	Diode	Fast Recovery Diode (Axial)	208	FKH0660	Transistor	MOS FET	168
BR200	DC/DC Power Module Board Surface-Mount Type		226	FKH1040	Transistor	MOS FET	168
BR201	DC/DC Power Module Board Surface-Mount Type		226	FKP202	Transistor	MOS FET	168
BR202	DC/DC Power Module Board Surface-Mount Type		228	FKP250A	Transistor	MOS FET	168
BR203	DC/DC Power Module Board Surface-Mount Type		228	FKP252	Transistor	MOS FET	168
BR204	DC/DC Power Module Board Surface-Mount Type		226	FKP253	Transistor	MOS FET	168
BR205	DC/DC Power Module Board Surface-Mount Type		230	FKP280A	Transistor	MOS FET	168
BR206	DC/DC Power Module Board Surface-Mount Type		232	FKP300A	Transistor	MOS FET	168
BR300	DC/DC Power Module Board Lead Type		234	FKP330C	Transistor	MOS FET	168
BR301	DC/DC Power Module Board Lead Type		234	FKV460S	Transistor	MOS FET	168
EG01	Diode	Ultrafast Recovery Diode (Axial)	211	FKV550N	Transistor	MOS FET	168
EG01A	Diode	Ultrafast Recovery Diode (Axial)	211	FKV575	Transistor	MOS FET	168
EG01C	Diode	Ultrafast Recovery Diode (Axial)	212	FKV660S	Transistor	MOS FET	168
EG1	Diode	Ultrafast Recovery Diode (Axial)	211	FM2-2202	Diode	Ultrafast Recovery Diode (Frame)	210
EG1A	Diode	Ultrafast Recovery Diode (Axial)	211	FMB-2204	Diode	Schottky Barrier Diode (Frame)	213
EH1	Diode	Fast Recovery Diode (Axial)	208	FMB-2304	Diode	Schottky Barrier Diode (Frame)	213
EK04	Diode	Schottky Barrier Diode (Axial)	213	FMB-2306	Diode	Schottky Barrier Diode (Frame)	214
EK06	Diode	Schottky Barrier Diode (Axial)	214	FMB-24	Diode	Schottky Barrier Diode (Frame)	213
EK09	Diode	Schottky Barrier Diode (Axial)	214	FMB-24H	Diode	Schottky Barrier Diode (Frame)	213
EK14	Diode	Schottky Barrier Diode (Axial)	213	FMB-24L	Diode	Schottky Barrier Diode (Frame)	213
EK16	Diode	Schottky Barrier Diode (Axial)	214	FMB-24M	Diode	Schottky Barrier Diode (Frame)	213
EK19	Diode	Schottky Barrier Diode (Axial)	214	FMB-26	Diode	Schottky Barrier Diode (Frame)	214
EKG1020	Transistor	MOS FET	168	FMB-29	Diode	Schottky Barrier Diode (Frame)	214
EKH04100	Transistor	MOS FET	168	FMB-29L	Diode	Schottky Barrier Diode (Frame)	214
EKH06100	Transistor	MOS FET	168	FMB-G14	Diode	Schottky Barrier Diode (F2pin)	213
EKH1070	Transistor	MOS FET	168	FMB-G14L	Diode	Schottky Barrier Diode (F2pin)	213
EKV550	Transistor	MOS FET	168	FMB-G16L	Diode	Schottky Barrier Diode (F2pin)	214
EL02Z	Diode	Ultrafast Recovery Diode (Axial)	210	FMB-G19L	Diode	Schottky Barrier Diode (F2pin)	214
EL1	Diode	Ultrafast Recovery Diode (Axial)	211	FMB-G24H	Diode	Schottky Barrier Diode (F2pin)	213
EL1Z	Diode	Ultrafast Recovery Diode (Axial)	210	FMC-26U	Diode	Ultrafast Recovery Diode (Frame)	211
EM01	Diode	Rectifier Diode (Axial)	207	FMC-26UA	Diode	Ultrafast Recovery Diode (F2Pin)	212
EM01A	Diode	Rectifier Diode (Axial)	207	FMC-28U	Diode	Ultrafast Recovery Diode (Frame)	212
EM01Z	Diode	Rectifier Diode (Axial)	207	FMC-28UA	Diode	Ultrafast Recovery Diode (F2Pin)	212
EM1	Diode	Rectifier Diode (Axial)	207	FMC-G28S	Diode	Ultrafast Recovery Diode (F2Pin)	212
EM1A	Diode	Rectifier Diode (Axial)	207	FMC-G28SL	Diode	Ultrafast Recovery Diode (F2Pin)	212
EM1B	Diode	Rectifier Diode (Axial)	207	FMD-1056S	Diode	Ultrafast Recovery Diode (F2Pin)	211
EM1C	Diode	Rectifier Diode (Axial)	207	FMD-1106S	Diode	Ultrafast Recovery Diode (F2Pin)	211
EM1Y	Diode	Rectifier Diode (Axial)	207	FMD-4204S	Diode	Ultrafast Recovery Diode (Frame)	211
EM1Z	Diode	Rectifier Diode (Axial)	207	FMD-4206S	Diode	Ultrafast Recovery Diode (Frame)	211
EM2	Diode	Rectifier Diode (Axial)	207	FMD-G26S	Diode	Ultrafast Recovery Diode (F2Pin)	211
EM2A	Diode	Rectifier Diode (Axial)	207	FMEN-210A	Diode	Schottky Barrier Diode (Frame)	215
EM2B	Diode	Rectifier Diode (Axial)	207	FMEN-210B	Diode	Schottky Barrier Diode (Frame)	215

Part No.	Category	Description	Page
FMEN-215A	Diode	Schottky Barrier Diode (Frame)	215
FMEN-2208	Diode	Schottky Barrier Diode (Frame)	215
FMEN-2308	Diode	Schottky Barrier Diode (Frame)	215
FMEN-220A	Diode	Schottky Barrier Diode (Frame)	215
FMEN-220B	Diode	Schottky Barrier Diode (Frame)	215
FMEN-230A	Diode	Schottky Barrier Diode (Frame)	215
FMEN-230B	Diode	Schottky Barrier Diode (Frame)	215
FMEN-420A	Diode	Schottky Barrier Diode (Frame)	215
FMEN-420B	Diode	Schottky Barrier Diode (Frame)	215
FMEN-430A	Diode	Schottky Barrier Diode (Frame)	215
FMG-14R	Diode	Ultrafast Recovery Diode (Frame)	211
FMG-14S	Diode	Ultrafast Recovery Diode (Frame)	211
FMG-24R	Diode	Ultrafast Recovery Diode (Frame)	211
FMG-24S	Diode	Ultrafast Recovery Diode (Frame)	211
FMG-26R	Diode	Ultrafast Recovery Diode (Frame)	211
FMG-26S	Diode	Ultrafast Recovery Diode (Frame)	211
FMG-G26S	Diode	Ultrafast Recovery Diode (F2Pin)	211
FMG-G2CS	Diode	Ultrafast Recovery Diode (F2Pin)	212
FMJ-2303	Diode	Schottky Barrier Diode (Frame)	215
FMJ-23L	Diode	Schottky Barrier Diode (Frame)	215
FML-12S	Diode	Ultrafast Recovery Diode (Frame)	210
FML-13S	Diode	Ultrafast Recovery Diode (Frame)	210
FML-14S	Diode	Ultrafast Recovery Diode (Frame)	211
FML-22S	Diode	Ultrafast Recovery Diode (Frame)	210
FML-23S	Diode	Ultrafast Recovery Diode (Frame)	210
FML-24S	Diode	Ultrafast Recovery Diode (Frame)	211
FML-4202S	Diode	Ultrafast Recovery Diode (Frame)	210
FML-4204S	Diode	Ultrafast Recovery Diode (Frame)	211
FML-G12S	Diode	Ultrafast Recovery Diode (F2Pin)	210
FML-G13S	Diode	Ultrafast Recovery Diode (F2Pin)	210
FML-G14S	Diode	Ultrafast Recovery Diode (F2Pin)	211
FML-G16S	Diode	Ultrafast Recovery Diode (F2Pin)	211
FML-G22S	Diode	Ultrafast Recovery Diode (F2Pin)	210
FMM-22R	Diode	Rectifier Diode (Frame)	207
FMM-22S	Diode	Rectifier Diode (Frame)	207
FMM-24R	Diode	Rectifier Diode (Frame)	207
FMM-24S	Diode	Rectifier Diode (Frame)	207
FMM-26R	Diode	Rectifier Diode (Frame)	207
FMM-26S	Diode	Rectifier Diode (Frame)	207
FMN-1056S	Diode	Ultrafast Recovery Diode (F2Pin)	211
FMN-1106S	Diode	Ultrafast Recovery Diode (F2Pin)	211
FMN-1206S	Diode	Ultrafast Recovery Diode (F2Pin)	211
FMN-2206S	Diode	Ultrafast Recovery Diode (Frame)	211
FMN-3306S	Diode	Ultrafast Recovery Diode (F2Pin)	211
FMN-4306S	Diode	Ultrafast Recovery Diode (Frame)	211
FMN-G12S	Diode	Ultrafast Recovery Diode (F2Pin)	210
FMN-G14S	Diode	Ultrafast Recovery Diode (F2Pin)	211
FMNS-1106S	Diode	Ultrafast Recovery Diode (F2Pin)	211
FMU-12R	Diode	Fast Recovery Diode (Frame)	208
FMU-12S	Diode	Fast Recovery Diode (Frame)	208
FMU-14R	Diode	Fast Recovery Diode (Frame)	208
FMU-14S	Diode	Fast Recovery Diode (Frame)	208
FMU-16R	Diode	Fast Recovery Diode (Frame)	208
FMU-16S	Diode	Fast Recovery Diode (Frame)	208
FMU-22R	Diode	Fast Recovery Diode (Frame)	208
FMU-22S	Diode	Fast Recovery Diode (Frame)	208
FMU-24R	Diode	Fast Recovery Diode (Frame)	208
FMU-24S	Diode	Fast Recovery Diode (Frame)	208
FMU-26R	Diode	Fast Recovery Diode (Frame)	208
FMU-26S	Diode	Fast Recovery Diode (Frame)	208
FMU-G16S	Diode	Fast Recovery Diode (F2Pin)	208
FMU-G26S	Diode	Fast Recovery Diode (F2Pin)	208
FMW-2106	Diode	Schottky Barrier Diode (Frame)	214
FMW-2156	Diode	Schottky Barrier Diode (Frame)	214

Part No.	Category	Description	Page
FMW-2204	Diode	Schottky Barrier Diode (Frame)	213
FMW-2206	Diode	Schottky Barrier Diode (Frame)	214
FMW-24H	Diode	Schottky Barrier Diode (Frame)	213
FMW-24L	Diode	Schottky Barrier Diode (Frame)	213
FMW-4304	Diode	Schottky Barrier Diode (Frame)	213
FMW-4306	Diode	Schottky Barrier Diode (Frame)	214
FMX-1106S	Diode	Ultrafast Recovery Diode (Frame)	211
FMX-12S	Diode	Ultrafast Recovery Diode (Frame)	210
FMX-2203	Diode	Ultrafast Recovery Diode (Frame)	210
FMX-22S	Diode	Ultrafast Recovery Diode (Frame)	210
FMX-22SL	Diode	Ultrafast Recovery Diode (Frame)	210
FMX-23S	Diode	Ultrafast Recovery Diode (Frame)	210
FMX-4202S	Diode	Ultrafast Recovery Diode (Frame)	210
FMX-4203S	Diode	Ultrafast Recovery Diode (Frame)	210
FMX-4206S	Diode	Ultrafast Recovery Diode (Frame)	211
FMXA-1054S	Diode	Ultrafast Recovery Diode (F2Pin)	211
FMXA-1104S	Diode	Ultrafast Recovery Diode (F2Pin)	211
FMXA-1106S	Diode	Ultrafast Recovery Diode (F2Pin)	211
FMXA-2102ST	Diode	Ultrafast Recovery Diode (Frame)	210
FMXA-2153S	Diode	Ultrafast Recovery Diode (Frame)	210
FMXA-2202S	Diode	Ultrafast Recovery Diode (Frame)	210
FMXA-2203S	Diode	Ultrafast Recovery Diode (Frame)	210
FMXA-4202S	Diode	Ultrafast Recovery Diode (Frame)	210
FMXA-4203S	Diode	Ultrafast Recovery Diode (Frame)	210
FMXA-4204S	Diode	Ultrafast Recovery Diode (Frame)	211
FMXA-4206S	Diode	Ultrafast Recovery Diode (Frame)	211
FMX-G12S	Diode	Ultrafast Recovery Diode (F2Pin)	210
FMX-G14S	Diode	Ultrafast Recovery Diode (F2Pin)	211
FMX-G16S	Diode	Ultrafast Recovery Diode (F2Pin)	211
FMX-G22S	Diode	Ultrafast Recovery Diode (F2Pin)	210
FMX-G26S	Diode	Ultrafast Recovery Diode (F2Pin)	211
FMXK-1086S	Diode	Ultrafast Recovery Diode (F2Pin)	211
FMXK-1106S	Diode	Ultrafast Recovery Diode (F2Pin)	211
FMXK-2206S	Diode	Ultrafast Recovery Diode (Frame)	211
FMXS-2206S	Diode	Ultrafast Recovery Diode (Frame)	211
FMXS-4202S	Diode	Ultrafast Recovery Diode (Frame)	210
FMY-1036S	Diode	Fast Recovery Diode (F2Pin)	208
FMY-1106S	Diode	Fast Recovery Diode (F2Pin)	208
FMY-2206S	Diode	Fast Recovery Diode (Frame)	208
LC5202D	IC	LED Driver IC	136
LC5202S	IC	LED Driver IC	136
LC5203D	IC	LED Driver IC	136
LC5205D	IC	LED Driver IC	136
LC5205S	IC	LED Driver IC	136
LC5210D	IC	LED Driver IC	136
LC5222D	IC	LED Driver IC	138
LC5222S	IC	LED Driver IC	138
LC5223D	IC	LED Driver IC	138
LC5225D	IC	LED Driver IC	138
LC5225S	IC	LED Driver IC	138
LC5226D	IC	LED Driver IC	138
LC5511D	IC	LED Driver IC	142
LC5513D	IC	LED Driver IC	142
LC5521D	IC	LED Driver IC	146
LC5523D	IC	LED Driver IC	146
LC5523F	IC	LED Driver IC	146
LC5525F	IC	LED Driver IC	146
LC5545LD	IC	LED Driver IC	148
LC5546LD	IC	LED Driver IC	148
LC5546LF	IC	LED Driver IC	148
LC5547LF	IC	LED Driver IC	148
LC5548LD	IC	LED Driver IC	148
LC5549LF	IC	LED Driver IC	148
LC5555LD	IC	LED Driver IC	140

Part No.	Category	Description	Page	Part No.	Category	Description	Page
LC5556LD	IC	LED Driver IC	140	RM4A	Diode	Rectifier Diode (Axial)	207
LC5565LD	IC	LED Driver IC	144	RM4AM	Diode	Rectifier Diode (Axial)	207
LC5566LD	IC	LED Driver IC	144	RM4C	Diode	Rectifier Diode (Axial)	207
LC5720S	IC	LED Driver IC	150	RM4Y	Diode	Rectifier Diode (Axial)	207
MGD623N	Transistor	IGBT	172	RM4Z	Diode	Rectifier Diode (Axial)	207
MGD623S	Transistor	IGBT	172	RM10	Diode	Rectifier Diode (Axial)	207
MKS5015	Transistor	MOS FET	168	RM10A	Diode	Rectifier Diode (Axial)	207
MKS5020	Transistor	MOS FET	168	RM10B	Diode	Rectifier Diode (Axial)	207
MPE-220A	Diode	Schottky Barrier Diode (Surface Mount)	213	RM10Z	Diode	Rectifier Diode (Axial)	207
MPEN-230AF	Diode	Schottky Barrier Diode	215	RM11A	Diode	Rectifier Diode (Axial)	207
MPL-102S	Diode	Ultrafast Recovery Diode (Surface Mount)	210	RM11B	Diode	Rectifier Diode (Axial)	207
MPL-1036S	Diode	Ultrafast Recovery Diode (Surface Mount)	210	RM11C	Diode	Rectifier Diode (Axial)	207
MPM01	DC/DC Power Module Mold Type		224	RN1Z	Diode	Ultrafast Recovery Diode (Axial)	210
MPM04	DC/DC Power Module Mold Type		224	RN2Z	Diode	Ultrafast Recovery Diode (Axial)	210
NR110K	IC	DC/DC Converter IC (Surface Mount)	20	RN4A	Diode	Ultrafast Recovery Diode (Axial)	211
NR111D	IC	DC/DC Converter IC	54	RN4Z	Diode	Ultrafast Recovery Diode (Axial)	210
NR111E	IC	DC/DC Converter IC (Surface Mount)	20	RO2	Diode	Rectifier Diode (Axial)	207
NR117K	IC	DC/DC Converter IC (Surface Mount)	20	RO2C	Diode	Rectifier Diode (Axial)	207
NR119E	IC	DC/DC Converter IC (Surface Mount)	20	RO2Z	Diode	Rectifier Diode (Axial)	207
NR301E	IC	Linear Regulator IC (Surface Mount)	74	RP1H	Diode	Ultrafast Recovery Diode (Axial)	212
NR885E	IC	DC/DC Converter IC (Surface Mount)	22	RS1A	Diode	Fast Recovery Diode (Axial)	208
NR885K	IC	DC/DC Converter IC (Surface Mount)	22	RS1B	Diode	Fast Recovery Diode (Axial)	209
NR887D	IC	DC/DC Converter IC	46	RS4FS	Diode	Fast Recovery Diode (Axial)	209
RA13	Diode	Schottky Barrier Diode (Axial)	214	RU1	Diode	Fast Recovery Diode (Axial)	208
RC2	Diode	Fast Recovery Diode (Axial)	209	RU1A	Diode	Fast Recovery Diode (Axial)	208
RD2A	Diode	Ultrafast Recovery Diode (Axial)	211	RU1B	Diode	Fast Recovery Diode (Axial)	209
RF1A	Diode	Fast Recovery Diode (Axial)	208	RU1C	Diode	Fast Recovery Diode (Axial)	209
RF1B	Diode	Fast Recovery Diode (Axial)	209	RU1P	Diode	Ultrafast Recovery Diode (Axial)	212
RG1C	Diode	Ultrafast Recovery Diode (Axial)	212	RU2	Diode	Fast Recovery Diode (Axial)	208
RG2	Diode	Ultrafast Recovery Diode (Axial)	211	RU2AM	Diode	Fast Recovery Diode (Axial)	208
RG2A	Diode	Ultrafast Recovery Diode (Axial)	211	RU2B	Diode	Fast Recovery Diode (Axial)	209
RG4C	Diode	Ultrafast Recovery Diode (Axial)	212	RU2C	Diode	Fast Recovery Diode (Axial)	209
RG10	Diode	Ultrafast Recovery Diode (Axial)	211	RU2M	Diode	Fast Recovery Diode (Axial)	208
RG10A	Diode	Ultrafast Recovery Diode (Axial)	211	RU2Z	Diode	Fast Recovery Diode (Axial)	208
RH1A	Diode	Fast Recovery Diode (Axial)	208	RU20A	Diode	Fast Recovery Diode (Axial)	208
RH1B	Diode	Fast Recovery Diode (Axial)	209	RU3	Diode	Fast Recovery Diode (Axial)	208
RH1C	Diode	Fast Recovery Diode (Axial)	209	RU3A	Diode	Fast Recovery Diode (Axial)	208
RH1Z	Diode	Fast Recovery Diode (Axial)	208	RU3AM	Diode	Fast Recovery Diode (Axial)	208
RJ43	Diode	Schottky Barrier Diode (Axial)	215	RU3B	Diode	Fast Recovery Diode (Axial)	209
RK14	Diode	Schottky Barrier Diode (Axial)	213	RU3C	Diode	Fast Recovery Diode (Axial)	209
RK16	Diode	Schottky Barrier Diode (Axial)	214	RU3M	Diode	Fast Recovery Diode (Axial)	208
RK19	Diode	Schottky Barrier Diode (Axial)	214	RU4	Diode	Fast Recovery Diode (Axial)	208
RK34	Diode	Schottky Barrier Diode (Axial)	213	RU4A	Diode	Fast Recovery Diode (Axial)	208
RK36	Diode	Schottky Barrier Diode (Axial)	214	RU4B	Diode	Fast Recovery Diode (Axial)	209
RK39	Diode	Schottky Barrier Diode (Axial)	214	RU4C	Diode	Fast Recovery Diode (Axial)	209
RK44	Diode	Schottky Barrier Diode (Axial)	213	RU4D	Diode	Fast Recovery Diode (Axial)	209
RK46	Diode	Schottky Barrier Diode (Axial)	214	RU4DS	Diode	Fast Recovery Diode (Axial)	209
RK49	Diode	Schottky Barrier Diode (Axial)	214	RU4M	Diode	Fast Recovery Diode (Axial)	208
RL2	Diode	Ultrafast Recovery Diode (Axial)	211	RU4Z	Diode	Fast Recovery Diode (Axial)	208
RL2Z	Diode	Ultrafast Recovery Diode (Axial)	210	RW54	Diode	Schottky Barrier Diode (Axial)	213
RL4A	Diode	Ultrafast Recovery Diode (Axial)	211	RX10Z	Diode	Ultrafast Recovery Diode (Axial)	210
RL4Z	Diode	Ultrafast Recovery Diode (Axial)	210	RY2A	Diode	Fast Recovery Diode (Axial)	208
RL10Z	Diode	Ultrafast Recovery Diode (Axial)	210	SAI01	IC	DC/DC Converter IC (Surface Mount)	12
RM1	Diode	Rectifier Diode (Axial)	207	SAI02	IC	DC/DC Converter IC (Surface Mount)	12
RM1A	Diode	Rectifier Diode (Axial)	207	SAI03	IC	DC/DC Converter IC (Surface Mount)	12
RM1B	Diode	Rectifier Diode (Axial)	207	SCM1241M	IC	High Voltage 3 Phase Motor Driver IC	130
RM1C	Diode	Rectifier Diode (Axial)	207	SCM1243MF	IC	High Voltage 3 Phase Motor Driver IC	130
RM1Z	Diode	Rectifier Diode (Axial)	207	SCM1245MF	IC	High Voltage 3 Phase Motor Driver IC	130
RM2	Diode	Rectifier Diode (Axial)	207	SCM1246MF	IC	High Voltage 3 Phase Motor Driver IC	130
RM2A	Diode	Rectifier Diode (Axial)	207	SCM1248M	IC	High Voltage 3 Phase Motor Driver IC	130
RM2B	Diode	Rectifier Diode (Axial)	207	SI-3010KD	IC	Linear Regulator IC (Surface Mount)	80
RM2C	Diode	Rectifier Diode (Axial)	207	SI-3010KF	IC	Linear Regulator IC	88
RM2Z	Diode	Rectifier Diode (Axial)	207	SI-3010LLSL	IC	Linear Regulator IC (Surface Mount)	84
RM4	Diode	Rectifier Diode (Axial)	207	SI-3011ZD	IC	Linear Regulator IC (Surface Mount)	86

Part No.	Category	Description	Page
SI-3011ZF	IC	Linear Regulator IC	90
SI-3012KD	IC	Linear Regulator IC (Surface Mount)	80
SI-3012KS	IC	Linear Regulator IC (Surface Mount)	78
SI-3012LU	IC	Linear Regulator IC (Surface Mount)	72
SI-3018LSA	IC	Linear Regulator IC (Surface Mount)	76
SI-3025KS	IC	Linear Regulator IC (Surface Mount)	78
SI-3025LSA	IC	Linear Regulator IC (Surface Mount)	76
SI-3033KD	IC	Linear Regulator IC (Surface Mount)	80
SI-3033KS	IC	Linear Regulator IC (Surface Mount)	78
SI-3033LSA	IC	Linear Regulator IC (Surface Mount)	76
SI-3033ZD	IC	Linear Regulator IC (Surface Mount)	86
SI-3050KD	IC	Linear Regulator IC (Surface Mount)	80
SI-3050LSA	IC	Linear Regulator IC (Surface Mount)	76
SI-6633C	IC	Low Voltage 3 Phase Motor Driver IC	118
SI-6633M	IC	Low Voltage 3 Phase Motor Driver IC	116
SI-7321M	IC	2-phase Stepper Motor Unipolar Driver IC	106
SI-7510	IC	5-phase Stepper Motor Driver IC	110
SI-8001FDE	IC	DC/DC Converter IC (Surface Mount)	34
SI-8001FDL	IC	DC/DC Converter IC (Surface Mount)	34
SI-8001FFE	IC	DC/DC Converter IC	52
SI-8005Q	IC	DC/DC Converter IC (Surface Mount)	32
SI-8008HD	IC	DC/DC Converter IC (Surface Mount)	36
SI-8008HFE	IC	DC/DC Converter IC	56
SI-8008TFE	IC	DC/DC Converter IC	42
SI-8008TM	IC	DC/DC Converter IC (Surface Mount)	18
SI-8010GL	IC	DC/DC Converter IC	44
SI-8010Y	IC	DC/DC Converter IC	58
SI-8015JF	IC	DC/DC Converter IC	40
SI-8033JD	IC	DC/DC Converter IC (Surface Mount)	16
SI-8033JF	IC	DC/DC Converter IC	40
SI-8033S	IC	DC/DC Converter IC	48
SI-8033SD	IC	DC/DC Converter IC (Surface Mount)	26
SI-8033W	IC	DC/DC Converter IC (Surface Mount)	14
SI-8050E	IC	DC/DC Converter IC	38
SI-8050HFE	IC	DC/DC Converter IC	56
SI-8050JD	IC	DC/DC Converter IC (Surface Mount)	16
SI-8050JF	IC	DC/DC Converter IC	40
SI-8050S	IC	DC/DC Converter IC	48
SI-8050SD	IC	DC/DC Converter IC (Surface Mount)	26
SI-8050TFE	IC	DC/DC Converter IC	42
SI-8050W	IC	DC/DC Converter IC (Surface Mount)	14
SI-8050Y	IC	DC/DC Converter IC	58
SI-8090JD	IC	DC/DC Converter IC (Surface Mount)	16
SI-8090S	IC	DC/DC Converter IC	48
SI-8105QL	IC	DC/DC Converter IC	50
SI-8120JD	IC	DC/DC Converter IC (Surface Mount)	16
SI-8120JF	IC	DC/DC Converter IC	40
SI-8120S	IC	DC/DC Converter IC	48
SI-8150S	IC	DC/DC Converter IC	48
SI-8205NHD	IC	DC/DC Converter IC (Surface Mount)	24
SI-8205NHG	IC	DC/DC Converter IC (Surface Mount)	24
SI-8401L	IC	DC/DC Converter IC (with Coil)	60
SI-8501L	IC	DC/DC Converter IC (with Coil)	60
SI-8511NVS	IC	DC/DC Converter IC (Surface Mount)	68
SIM6811M	IC	High Voltage 3 Phase Motor Driver IC	128
SIM6812M	IC	High Voltage 3 Phase Motor Driver IC	128
SIM6822M	IC	High Voltage 3 Phase Motor Driver IC	128
SIM6827M	IC	High Voltage 3 Phase Motor Driver IC	128
SJPA-D3	Diode	Schottky Barrier Diode (Surface Mount)	214
SJPA-H3	Diode	Schottky Barrier Diode (Surface Mount)	214
SJPA-L3	Diode	Schottky Barrier Diode (Surface Mount)	214
SJPB-D4	Diode	Schottky Barrier Diode (Surface Mount)	213
SJPB-D6	Diode	Schottky Barrier Diode (Surface Mount)	213
SJPB-D9	Diode	Schottky Barrier Diode (Surface Mount)	213

Part No.	Category	Description	Page
SJPB-H4	Diode	Schottky Barrier Diode (Surface Mount)	213
SJPB-H6	Diode	Schottky Barrier Diode (Surface Mount)	213
SJPB-H9	Diode	Schottky Barrier Diode (Surface Mount)	213
SJPB-L4	Diode	Schottky Barrier Diode (Surface Mount)	213
SJPB-L6	Diode	Schottky Barrier Diode (Surface Mount)	213
SJPD-D5	Diode	Ultrafast Recovery Diode (Surface Mount)	210
SJPD-L5	Diode	Ultrafast Recovery Diode (Surface Mount)	210
SJPE-H3	Diode	Schottky Barrier Diode (Surface Mount)	215
SJPE-H4	Diode	Schottky Barrier Diode (Surface Mount)	215
SJPJ-D3	Diode	Schottky Barrier Diode (Surface Mount)	215
SJPJ-H3	Diode	Schottky Barrier Diode (Surface Mount)	215
SJPL-L3	Diode	Schottky Barrier Diode (Surface Mount)	215
SJPL-D2	Diode	Ultrafast Recovery Diode (Surface Mount)	210
SJPL-F4	Diode	Ultrafast Recovery Diode (Surface Mount)	210
SJPL-H2	Diode	Ultrafast Recovery Diode (Surface Mount)	210
SJPL-H6	Diode	Ultrafast Recovery Diode (Surface Mount)	210
SJPL-L2	Diode	Ultrafast Recovery Diode (Surface Mount)	210
SJPL-L4	Diode	Ultrafast Recovery Diode (Surface Mount)	210
SJPM-H4	Diode	Rectifier Diode (Surface Mount)	207
SJPW-F6	Diode	Schottky Barrier Diode (Surface Mount)	213
SJPW-T4	Diode	Schottky Barrier Diode (Surface Mount)	213
SJPX-F2	Diode	Ultrafast Recovery Diode (Surface Mount)	210
SJPX-H3	Diode	Ultrafast Recovery Diode (Surface Mount)	210
SJPX-H6	Diode	Ultrafast Recovery Diode (Surface Mount)	210
SJPE-E20	Diode	Power Zener Diode (Surface Mount)	216
SJPE-E33	Diode	Power Zener Diode (Surface Mount)	216
SJPE-K28	Diode	Power Zener Diode (Surface Mount)	216
SJPE-N18	Diode	Power Zener Diode (Surface Mount)	216
SJPE-N27	Diode	Power Zener Diode (Surface Mount)	216
SJPE-N33	Diode	Power Zener Diode (Surface Mount)	216
SJPE-N40	Diode	Power Zener Diode (Surface Mount)	216
SKH04100	Transistor	MOS FET	168
SKH06100	Transistor	MOS FET	168
SKH1070	Transistor	MOS FET	168
SKP202	Transistor	MOS FET	168
SKP253	Transistor	MOS FET	168
SLA4030	Thyristor	Array for Sink Drive	174
SLA4031	Thyristor	Array for Sink Drive	174
SLA4036	Thyristor	Array for Sink Drive	174
SLA4041	Thyristor	Array for Sink Drive	174
SLA4051	Thyristor	Array for Sink Drive	174
SLA4052	Thyristor	Array for Sink Drive	174
SLA4060	Thyristor	Array for Sink Drive	174
SLA4061	Thyristor	Array for Sink Drive	174
SLA4070	Thyristor	Array for Source Drive	174
SLA4071	Thyristor	Array for Source Drive	174
SLA4390	Thyristor	Array for H-Bridge Motor Drive	174
SLA5037	Thyristor	Array for Sink Drive	174
SLA5041	Thyristor	Array for Sink Drive	174
SLA5059	Thyristor	Array for 3-Phase Motor Drive	174
SLA5060	Thyristor	Array for 3-Phase Motor Drive	174
SLA5061	Thyristor	Array for 3-Phase Motor Drive	174
SLA5064	Thyristor	Array for 3-Phase Motor Drive	174
SLA5065	Thyristor	Array for 5-Phase Motor Drive	174
SLA5068	Thyristor	Array for 5-Phase Motor Drive	174
SLA5073	Thyristor	Array for 5-Phase Motor Drive	174
SLA5074	Thyristor	Array for 5-Phase Motor Drive	174
SLA5075	Thyristor	Array for 3-Phase Motor Drive	174
SLA5085	Thyristor	Array for Sink Drive	174
SLA5086	Thyristor	Array for Source Drive	174
SLA5096	Thyristor	Array for 3-Phase Motor Drive	174
SLA5201	Thyristor	Array for 3-Phase Motor Drive	174
SLA5212	Thyristor	Array for 3-Phase Motor Drive	174
SLA5222	Thyristor	Array for Partial switching PFC	174

Part No.	Category	Description	Page	Part No.	Category	Description	Page
SLA5227	Thyristor	Array for Partial switching PFC	174	SMA6823MH	IC	High Voltage 3 Phase Motor Driver IC	122
SLA6012	Thyristor	Array for 3-Phase Motor Drive	174	SMA6862MZ	IC	High Voltage 3 Phase Motor Driver IC	124
SLA6020	Thyristor	Array for 3-Phase Motor Drive	174	SMA6863MZ	IC	High Voltage 3 Phase Motor Driver IC	124
SLA6022	Thyristor	Array for 3-Phase Motor Drive	174	SMA6865MZ	IC	High Voltage 3 Phase Motor Driver IC	124
SLA6023	Thyristor	Array for 3-Phase Motor Drive	174	SMA7022MU	IC	2-phase Stepper Motor Unipolar Driver IC	96
SLA6024	Thyristor	Array for 3-Phase Motor Drive	174	SMA7029M	IC	2-phase Stepper Motor Unipolar Driver IC	96
SLA6026	Thyristor	Array for 3-Phase Motor Drive	174	SPI-6631M	IC	Low Voltage 3 Phase Motor Driver IC	114
SLA6868MZ	IC	High Voltage 3 Phase Motor Driver IC	126	SPI-8001TW	IC	DC/DC Converter IC (2 Output, Surface Mount)	64
SLA6870MZ	IC	High Voltage 3 Phase Motor Driver IC	126	SPI-8002TW	IC	DC/DC Converter IC (2 Output, Surface Mount)	64
SLA7022MU	IC	2-phase Stepper Motor Unipolar Driver IC	96	SPI-8003TW	IC	DC/DC Converter IC (2 Output, Surface Mount)	64
SLA7024M	IC	2-phase Stepper Motor Unipolar Driver IC	98	SPI-8010A	IC	DC/DC Converter IC (Surface Mount)	28
SLA7026M	IC	2-phase Stepper Motor Unipolar Driver IC	98	SSC2001S	IC	PFC IC	6
SLA7027MU	IC	2-phase Stepper Motor Unipolar Driver IC	98	SSC2101S	IC	PFC IC	6
SLA7029M	IC	2-phase Stepper Motor Unipolar Driver IC	96	SSC2102S	IC	PFC IC	6
SLA7070MPR	IC	2-phase Stepper Motor Unipolar Driver IC	100	SSC9512	IC	AC/DC Converter IC	8
SLA7070MPRT	IC	2-phase Stepper Motor Unipolar Driver IC	100	SSC9522S	IC	AC/DC Converter IC	8
SLA7070MR	IC	2-phase Stepper Motor Unipolar Driver IC	100	STA301A	Transistor	Array for Sink Drive	175
SLA7071MPR	IC	2-phase Stepper Motor Unipolar Driver IC	100	STA302A	Transistor	Array for 3-Phase Motor Drive and Source Drive	175
SLA7071MPRT	IC	2-phase Stepper Motor Unipolar Driver IC	100	STA303A	Transistor	Array for 3-Phase Motor Drive and Sink Drive	175
SLA7071MR	IC	2-phase Stepper Motor Unipolar Driver IC	100	STA322A	Transistor	Array for Source Drive	175
SLA7072MPR	IC	2-phase Stepper Motor Unipolar Driver IC	100	STA401A	Transistor	Array for Sink Drive	175
SLA7072MPRT	IC	2-phase Stepper Motor Unipolar Driver IC	100	STA402A	Transistor	Array for Source Drive	175
SLA7072MR	IC	2-phase Stepper Motor Unipolar Driver IC	100	STA403A	Transistor	Array for Sink Drive	175
SLA7073MPR	IC	2-phase Stepper Motor Unipolar Driver IC	100	STA404A	Transistor	Array for Sink Drive	175
SLA7073MPRT	IC	2-phase Stepper Motor Unipolar Driver IC	100	STA406A	Transistor	Array for Sink Drive	175
SLA7073MR	IC	2-phase Stepper Motor Unipolar Driver IC	100	STA408A	Transistor	Array for Source Drive	175
SLA7075MPR	IC	2-phase Stepper Motor Unipolar Driver IC	108	STA412A	Transistor	Array for Sink Drive	175
SLA7075MPRT	IC	2-phase Stepper Motor Unipolar Driver IC	108	STA413A	Transistor	Array for Sink Drive	175
SLA7075MR	IC	2-phase Stepper Motor Unipolar Driver IC	108	STA421A	Transistor	Array for Sink Drive	175
SLA7076MPR	IC	2-phase Stepper Motor Unipolar Driver IC	108	STA431A	Transistor	Array for H-Bridge Motor Drive	175
SLA7076MPRT	IC	2-phase Stepper Motor Unipolar Driver IC	108	STA434A	Transistor	Array for H-Bridge Motor Drive	175
SLA7076MR	IC	2-phase Stepper Motor Unipolar Driver IC	108	STA457C	Transistor	Array for H-Bridge Motor Drive	175
SLA7077MPR	IC	2-phase Stepper Motor Unipolar Driver IC	108	STA460C	Transistor	Array for Sink Drive	175
SLA7077MPRT	IC	2-phase Stepper Motor Unipolar Driver IC	108	STA471A	Transistor	Array for Sink Drive	175
SLA7077MR	IC	2-phase Stepper Motor Unipolar Driver IC	108	STA472A	Transistor	Array for Source Drive	175
SLA7078MPR	IC	2-phase Stepper Motor Unipolar Driver IC	108	STA473A	Transistor	Array for Sink Drive	175
SLA7078MPRT	IC	2-phase Stepper Motor Unipolar Driver IC	108	STA475A	Transistor	Array for Sink Drive	175
SLA7078MR	IC	2-phase Stepper Motor Unipolar Driver IC	108	STA481A	Transistor	Array for Sink Drive	175
SLA7080MPR	IC	2-phase Stepper Motor Unipolar Driver IC	102	STA485A	Transistor	Array for Sink Drive	175
SLA7081MPR	IC	2-phase Stepper Motor Unipolar Driver IC	102	STA6940M	IC	Brush DC Motor Driver IC	112
SLA7082MPR	IC	2-phase Stepper Motor Unipolar Driver IC	102	STA7130MPR	IC	2-phase Stepper Motor Unipolar Driver IC	104
SLA7083MPR	IC	2-phase Stepper Motor Unipolar Driver IC	102	STA7131MPR	IC	2-phase Stepper Motor Unipolar Driver IC	104
SMA4020	Transistor	Array for Source Drive	175	STA7132MPR	IC	2-phase Stepper Motor Unipolar Driver IC	104
SMA4021	Transistor	Array for Source Drive	175	STA801M	IC	DC/DC Converter IC (2 Output)	62
SMA4030	Transistor	Array for Sink Drive	175	STD01N	Transistor	Audio (Darlington)	164
SMA4032	Transistor	Array for Sink Drive	175	STD01P	Transistor	Audio (Darlington)	164
SMA4033	Transistor	Array for Sink Drive	175	STD03N	Transistor	Audio (Darlington)	164
SMA4036	Transistor	Array for Sink Drive	175	STD03P	Transistor	Audio (Darlington)	164
SMA4038	Transistor	Array for Sink Drive	175	STR2W152D	IC	AC/DC Converter IC	6
SMA5106	Transistor	Array for Sink Drive	175	STR2W153D	IC	AC/DC Converter IC	6
SMA5112	Transistor	Array for 3-Phase Motor Drive	175	STR3A151	IC	AC/DC Converter IC	6
SMA5117	Transistor	Array for 3-Phase Motor Drive	175	STR3A151D	IC	AC/DC Converter IC	6
SMA5118	Transistor	Array for 3-Phase Motor Drive	175	STR3A152	IC	AC/DC Converter IC	6
SMA5125	Transistor	Array for 3-Phase Motor Drive	175	STR3A152D	IC	AC/DC Converter IC	6
SMA5127	Transistor	Array for 3-Phase Motor Drive	175	STR3A153	IC	AC/DC Converter IC	6
SMA5130	Transistor	Array for 3-Phase Motor Drive	175	STR3A153D	IC	AC/DC Converter IC	6
SMA5131	Transistor	Array for 3-Phase Motor Drive	175	STR3A154	IC	AC/DC Converter IC	6
SMA5132	Transistor	Array for 3-Phase Motor Drive	175	STR3A154D	IC	AC/DC Converter IC	6
SMA5133	Transistor	Array for 3-Phase Motor Drive	175	STR3A155	IC	AC/DC Converter IC	6
SMA6010	Transistor	Array for 3-Phase Motor Drive	175	STR3A155D	IC	AC/DC Converter IC	6
SMA6080	Transistor	Array for 3-Phase Motor Drive	175	STR3A161HD	IC	AC/DC Converter IC	6
SMA6511	Transistor	Array for Stepper Motor drive	175	STR3A162HD	IC	AC/DC Converter IC	6
SMA6821MH	IC	High Voltage 3 Phase Motor Driver IC	122	STR3A163HD	IC	AC/DC Converter IC	6
SMA6822MH	IC	High Voltage 3 Phase Motor Driver IC	122	STR-A6051M	IC	AC/DC Converter IC	6

Part Number Index

Part No.	Category	Description	Page
STR-A6052M	IC	AC/DC Converter IC	6
STR-A6053M	IC	AC/DC Converter IC	6
STR-A6059H	IC	AC/DC Converter IC	6
STR-A6061H	IC	AC/DC Converter IC	6
STR-A6061HD	IC	AC/DC Converter IC	6
STR-A6062H	IC	AC/DC Converter IC	6
STR-A6062HD	IC	AC/DC Converter IC	6
STR-A6063HD	IC	AC/DC Converter IC	6
STR-A6069H	IC	AC/DC Converter IC	6
STR-A6069HD	IC	AC/DC Converter IC	6
STR-A6079M	IC	AC/DC Converter IC	6
STR-A6131	IC	AC/DC Converter IC	7
STR-A6131M	IC	AC/DC Converter IC	7
STR-A6132	IC	AC/DC Converter IC	7
STR-A6151	IC	AC/DC Converter IC	7
STR-A6151M	IC	AC/DC Converter IC	7
STR-A6153E	IC	AC/DC Converter IC	7
STR-A6159	IC	AC/DC Converter IC	7
STR-A6159M	IC	AC/DC Converter IC	7
STR-A6169	IC	AC/DC Converter IC	7
STR-L451	IC	AC/DC Converter IC	8
STR-L472	IC	AC/DC Converter IC	8
STR-L6472	IC	AC/DC Converter IC	8
STR-V152	IC	AC/DC Converter IC	7
STR-V153	IC	AC/DC Converter IC	7
STR-V653	IC	AC/DC Converter IC	6
STR-W6051S	IC	AC/DC Converter IC	7
STR-W6052S	IC	AC/DC Converter IC	7
STR-W6053S	IC	AC/DC Converter IC	7
STR-W6251D	IC	AC/DC Converter IC	7
STR-W6252D	IC	AC/DC Converter IC	7
STR-W6253D	IC	AC/DC Converter IC	7
STR-W6723N	IC	AC/DC Converter IC	8
STR-W6734	IC	AC/DC Converter IC	8
STR-W6735	IC	AC/DC Converter IC	8
STR-W6735N	IC	AC/DC Converter IC	8
STR-W6750F	IC	AC/DC Converter IC	8
STR-W6753	IC	AC/DC Converter IC	8
STR-W6754	IC	AC/DC Converter IC	8
STR-W6756	IC	AC/DC Converter IC	8
STR-W6756N	IC	AC/DC Converter IC	8
STR-W6765	IC	AC/DC Converter IC	8
STR-W6765N	IC	AC/DC Converter IC	8
STR-X6729	IC	AC/DC Converter IC	8
STR-X6737	IC	AC/DC Converter IC	8
STR-X6737M	IC	AC/DC Converter IC	8
STR-X6750B	IC	AC/DC Converter IC	8
STR-X6750F	IC	AC/DC Converter IC	8
STR-X6756	IC	AC/DC Converter IC	8
STR-X6757	IC	AC/DC Converter IC	8
STR-X6757N	IC	AC/DC Converter IC	8
STR-X6759B	IC	AC/DC Converter IC	8
STR-X6759F	IC	AC/DC Converter IC	8
STR-X6759N	IC	AC/DC Converter IC	8
STR-X6768N	IC	AC/DC Converter IC	8
STR-X6769	IC	AC/DC Converter IC	8
STR-X6769B	IC	AC/DC Converter IC	8
STR-Y6453	IC	AC/DC Converter IC	7
STR-Y6456	IC	AC/DC Converter IC	7
STR-Y6473	IC	AC/DC Converter IC	7
STR-Y6476	IC	AC/DC Converter IC	7
STR-Y6735	IC	AC/DC Converter IC	7
STR-Y6753	IC	AC/DC Converter IC	7
STR-Y6754	IC	AC/DC Converter IC	7

Part No.	Category	Description	Page
STR-Y6763	IC	AC/DC Converter IC	7
STR-Y6765	IC	AC/DC Converter IC	7
STR-Y6766	IC	AC/DC Converter IC	7
SV-3SS	Diode	Silicon Varistor (Axial)	217
SV-4SS	Diode	Silicon Varistor (Axial)	217
SX68001MH	IC	High Voltage 3 Phase Motor Driver IC	120
SX68002MH	IC	High Voltage 3 Phase Motor Driver IC	120
SX68003MH	IC	High Voltage 3 Phase Motor Driver IC	120
SZ-10N27	Diode	Power Zener Diode (Surface Mount)	216
SZ-10N40	Diode	Power Zener Diode (Surface Mount)	216
SZ-10NN27	Diode	Power Zener Diode (Surface Mount)	216
SZ-10NN40	Diode	Power Zener Diode (Surface Mount)	216
TF541S-A	Thyristor	Thyristor	194
TF561S-A	Thyristor	Thyristor	194
TFA37S	Thyristor	Thyristor	194
TFA38S	Thyristor	Thyristor	194
TFA57S	Thyristor	Thyristor	194
TFA58S	Thyristor	Thyristor	194
TFA87S	Thyristor	Thyristor	194
TFA88S	Thyristor	Thyristor	194
TFA107S	Thyristor	Thyristor	194
TFA108S	Thyristor	Thyristor	194
TFC563D	Thyristor	Thyristor for HID Lamp Ignition	194
TMA34S-L	Thyristor	Triac	196
TMA36G-L	Thyristor	Triac	196
TMA36H-L	Thyristor	Triac	196
TMA36S-L	Thyristor	Triac	196
TMA54S-L	Thyristor	Triac	196
TMA56G-L	Thyristor	Triac	196
TMA56H-L	Thyristor	Triac	196
TMA56S-L	Thyristor	Triac	196
TMA84S-L	Thyristor	Triac	196
TMA86G-L	Thyristor	Triac	196
TMA86H-L	Thyristor	Triac	196
TMA86S-L	Thyristor	Triac	196
TMA104S-L	Thyristor	Triac	196
TMA106G-L	Thyristor	Triac	196
TMA106H-L	Thyristor	Triac	196
TMA106S-L	Thyristor	Triac	196
TMA124S-L	Thyristor	Triac	196
TMA126G-L	Thyristor	Triac	196
TMA126H-L	Thyristor	Triac	196
TMA126S-L	Thyristor	Triac	196
TMA164B-L	Thyristor	Triac	196
TMA164P-L	Thyristor	Triac	196
TMA164S-L	Thyristor	Triac	196
TMA166B-L	Thyristor	Triac	196
TMA166G-L	Thyristor	Triac	196
TMA166H-L	Thyristor	Triac	196
TMA166P-L	Thyristor	Triac	196
TMA166S-L	Thyristor	Triac	196
TMA204S-L	Thyristor	Triac	196
TMA206S-L	Thyristor	Triac	196
TMA254B-L	Thyristor	Triac	196
TMA256B-L	Thyristor	Triac	196
TMB166S-L	Thyristor	Triac	196
TMB206S-L	Thyristor	Triac	196
VR-60SS	Diode	Silicon Varistor (Axial)	217
VR-61SS	Diode	Silicon Varistor (Axial)	217



SanKen Electric Co., Ltd.
Overseas Sales Headquarters
Metropolitan Plaza Building, 1-11-1 Nishi-Ikebukuro
Toshima-ku, Tokyo 171-0021, Japan
Tel: 81-3-3986-6164
Fax: 81-3-3986-8637

WORLDWIDE SALES OFFICES

Asia-Pacific

● China

SanKen Electric Hong Kong Co., Ltd.
Suite 1026 Ocean Centre, Canton Road
Tsimshatsui, Kowloon, Hong Kong
Tel: 852-2735-5262
Fax: 852-2735-5494

SanKen Electric (Shanghai) Co., Ltd.
Room 3202, Maxdo Centre, Xingyi Road 8
Changning District, Shanghai, China
Tel: 86-21-5208-1177
Fax: 86-21-5208-1757

SanKen Electric (Shanghai) Co., Ltd. Shenzhen Office
Room 1013, Xinhua Insurance Building, Mintian Road, Futian District,
Shenzhen City, Guangdong, China
Tel: 86-755-8283-6685
Fax: 86-755-8826-3053

Taiwan SanKen Electric Co., Ltd.
Room 1801, 18th Floor, 88 Jung Shiau East Road
Sec. 2, Taipei 100, Taiwan R.O.C.
Tel: 886-2-2356-8161
Fax: 886-2-2356-8261

● Korea

SanKen Electric Korea Co., Ltd.
(Yeouido B/D 16F)24, Gukjegeumyung-ro 2-gil,
Yeongdeungpo-gu, Seoul 150-734, Korea
Tel: 82-2-714-3700
Fax: 82-2-3272-2145

● Singapore

SanKen Electric Singapore Pte. Ltd.
152 Beach Road, #10-06 The Gateway East,
Singapore 189721
Tel: 65-6291-4755
Fax: 65-6297-1744

● Malaysia

SanKen Electric (Malaysia) Sdn. Bhd.
Block B-20-5, Level 20, Northpoint Midvalley City,
No.1, Medan Syed Putra Utara, 59200 Kuala Lumpur, Malaysia
Tel: 60-3-2282-2345
Fax: 60-3-2282-6345

Europe

● United Kingdom

SanKen Power Systems (UK) Ltd.
Pencoed Technology Park
Pencoed, Bridgend CF35 5HY, United Kingdom
Tel: 44-1656-869-100
Fax: 44-1656-869-162

North America

● United States

Allegro MicroSystems, Inc.
115 Northeast Cutoff
Worcester, Massachusetts 01606, U.S.A.
Tel: 1-508-853-5000
Fax: 1-508-853-7895

● This is notification that you, as purchaser of the products/technology, are not allowed to perform any of the following:
1. Resell or retransfer these products/technology to any party intending to disturb international peace and security.
2. Use these products/technology yourself for activities disturbing international peace and security.
3. Allow any other party to use these products/technology for activities disturbing international peace and security.
Also, as purchaser of these products/technology, you agree to follow the procedures for the export or transfer of these products/technology, under the Foreign Exchange and Foreign Trade Law, when you export or transfer the products/technology abroad.



Looking for pricing, stock, or lifecycle information?

Click below to explore more details on WIN SOURCE:

 [View FGM623S](#) on WIN SOURCE

 [Sanken](#) Information

Optimize Your Supply Chain with WIN SOURCE Solutions

-  Global Sourcing Solution
-  Obsolete Management
-  Cost Control Management
-  Shortage Management
-  Alternative Solution
-  Excess Inventory Management