



# THE DATASHEET OF LM57BISD-10/NOPB



# LM57 Resistor-Programmable Temperature Switch and Analog Temperature Sensor

## 1 Features

- See [LM57-Q1](#) Data Sheet for AEC-Q100 Grade 1/Grade 0/Grade 0 Extended (Qualified and Manufactured on an Automotive Grade Flow)
- Trip Temperature Set by External Resistors with Accuracy of  $\pm 1.7^{\circ}\text{C}$  or  $\pm 2.3^{\circ}\text{C}$  from  $-40^{\circ}\text{C}$  to  $+150^{\circ}\text{C}$
- Resistor Tolerance Contributes Zero Error
- Push-Pull and Open-Drain Switch Outputs
- Wide Operating Temperature Range of  $-50^{\circ}\text{C}$  to  $150^{\circ}\text{C}$
- Very Linear Analog  $V_{\text{TEMP}}$  Temp Sensor Output with  $\pm 0.8^{\circ}\text{C}$  or  $\pm 1.3^{\circ}\text{C}$  Accuracy from  $-50^{\circ}\text{C}$  to  $+150^{\circ}\text{C}$
- Short-Circuit Protected Analog and Digital Outputs
- Latching Function for Digital Outputs
- TRIP-TEST Pin Allows In-System Testing
- Low Power Minimizes Self-Heating to Under  $0.02^{\circ}\text{C}$

## 2 Applications

- Factory Automation
- Industrial
- Automotive
- Down Hole
- Avionics
- Telecom Infrastructure

## 3 Description

The LM57 device is a precision, dual-output, temperature switch with analog temperature sensor output for wide temperature industrial applications. The trip temperature ( $T_{\text{TRIP}}$ ) is selected from 256 possible values in the range of  $-40^{\circ}\text{C}$  to  $150^{\circ}\text{C}$ . The  $V_{\text{TEMP}}$  is a class AB analog voltage output that is proportional to temperature with a programmable negative temperature coefficient (NTC). Two external 1% resistors set the  $T_{\text{TRIP}}$  and  $V_{\text{TEMP}}$  slope. The digital and analog outputs enable protection and monitoring of system thermal events.

Built-in thermal hysteresis ( $T_{\text{HYST}}$ ) prevents the digital outputs from oscillating. The  $T_{\text{OVER}}$  and  $\overline{T_{\text{OVER}}}$  digital outputs will assert when the die temperature exceeds  $T_{\text{TRIP}}$  and will de-assert when the temperature falls below a temperature equal to  $T_{\text{TRIP}}$  minus  $T_{\text{HYST}}$ .

$T_{\text{OVER}}$  is active-high with a push-pull structure.  $\overline{T_{\text{OVER}}}$  is active-low with an open-drain structure. Tying  $T_{\text{OVER}}$  to TRIP-TEST will latch the output after it trips. The output can be cleared by forcing TRIP-TEST low. Driving the TRIP-TEST high will assert the digital outputs. A processor can check the state of  $T_{\text{OVER}}$  or  $\overline{T_{\text{OVER}}}$ , confirming they changed to an active state. This allows for in situ verification that the comparator and output circuitry are functional after system assembly. When TRIP-TEST is high, the trip-level reference voltage appears at the  $V_{\text{TEMP}}$  pin. The system could then use this voltage to calculate the threshold of the LM57.

### Device Information (1) (2)

PART NUMBER	PACKAGE	BODY SIZE (NOM)
LM57BISD	WSON (8)	2.50 mm x 2.50 mm
LM57FPW	TSSOP (8)	3.00 mm x 6.40 mm

(1) For all available packages, see the orderable addendum at the end of the data sheet.

(2) For device comparison see [Device Comparison Table](#).

### LM57 Overtemperature Alarm

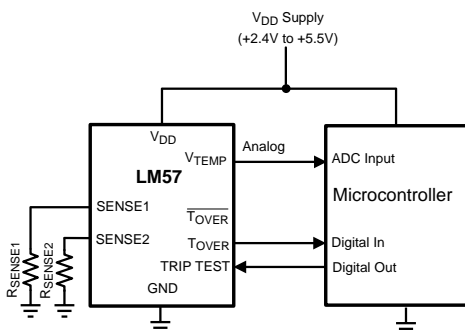

### Temperature Transfer Function

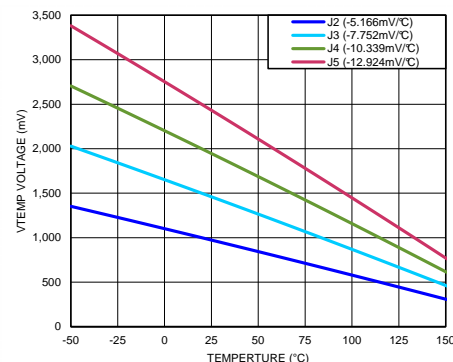

## Table of Contents

<b>1 Features</b> ..... 1 <b>2 Applications</b> ..... 1 <b>3 Description</b> ..... 1 <b>4 Revision History</b> ..... 2 <b>5 Device Comparison Table</b> ..... 3 <b>6 Pin Configuration and Functions</b> ..... 4 <b>7 Specifications</b> ..... 5 7.1 Absolute Maximum Ratings ..... 5 7.2 ESD Ratings ..... 5 7.3 Recommended Operating Conditions ..... 5 7.4 Thermal Information ..... 6 7.5 Electrical Characteristics - Accuracy Characteristics – Trip Point Accuracy ..... 7 7.6 Electrical Characteristics - Accuracy Characteristics – $V_{TEMP}$ Analog Temperature Sensor Output Accuracy ..... 7 7.7 Electrical Characteristics ..... 8 7.8 Switching Characteristics ..... 9 7.9 Typical Characteristics ..... 10 <b>8 Detailed Description</b> ..... 12	8.1 Overview ..... 12 8.2 Functional Block Diagram ..... 12 8.3 Feature Description ..... 13 8.4 Device Functional Modes ..... 23 <b>9 Application and Implementation</b> ..... 26 9.1 Application Information ..... 26 9.2 Typical Application ..... 26 <b>10 Power Supply Recommendations</b> ..... 28 <b>11 Layout</b> ..... 28 11.1 Layout Guidelines ..... 28 11.2 Layout Example ..... 29 11.3 Temperature Considerations ..... 30 <b>12 Device and Documentation Support</b> ..... 31 12.1 Documentation Support ..... 31 12.2 Community Resources ..... 31 12.3 Trademarks ..... 31 12.4 Electrostatic Discharge Caution ..... 31 12.5 Glossary ..... 31 <b>13 Mechanical, Packaging, and Orderable Information</b> ..... 31
--	--

## 4 Revision History

NOTE: Page numbers for previous revisions may differ from page numbers in the current version.

Changes from Revision D (February 2013) to Revision E	Page
<ul style="list-style-type: none"> <li>• Added <i>Pin Configuration and Functions</i> section, <i>ESD Ratings</i> table, <i>Feature Description</i> section, <i>Device Functional Modes</i>, <i>Application and Implementation</i> section, <i>Power Supply Recommendations</i> section, <i>Layout</i> section, <i>Device and Documentation Support</i> section, and <i>Mechanical, Packaging, and Orderable Information</i> section ..... 1</li> <li>• Added TSSOP Package option throughout data sheet ..... 1</li> </ul>	

Changes from Revision C (February 2010) to Revision D	Page
<ul style="list-style-type: none"> <li>• Changed layout of National Data Sheet to TI format ..... 1</li> </ul>	

## 5 Device Comparison Table

ORDER NUMBER	PACKAGE	GRADE (TEMP RANGE)	V <sub>TEMP</sub> ACCURACY	TRIP POINT ACCURACY	HYSTERESIS
LM57BISD-5, LM57BISDX-5	WSON/SD/NGR /DFN (8)	Commercial (-50°C to 150°C)	±0.8°C	±1.5°C	5°C
LM57BISD-10, LM57BISDX-10	WSON/SD/NGR /DFN (8)	Commercial (-50°C to 150°C)	±0.8°C	±1.5°C	10°C
LM57CISD-5, LM57CISD-5	WSON/SD/NGR /DFN (8)	Commercial (-50°C to 150°C)	±1.3°C	±2.3°C	5°C
LM57CISD-10, LM57CISDX-10	WSON/SD/NGR /DFN (8)	Commercial (-50°C to 150°C)	±1.3°C	±2.3°C	10°C
LM57FPW, LM57FPWR	PW/TSSOP (8)	Commercial (-50°C to 150°C)	±1.3°C	±2.3°C	5°C
LM57TPW, LM57TPWR	PW/TSSOP (8)	Commercial (-50°C to 150°C)	±1.3°C	±2.3°C	10°C
LM57FSPWQ1, LM57FSPWRQ1 <sup>(1)</sup>	PW/TSSOP (8)	Automotive Grade 0 Extended (-50°C to 160°C)	±1.3°C	±2.3°C	5°C
LM57TSPWQ1, LM57TSPWRQ1 <sup>(1)</sup>	PW/TSSOP (8)	Automotive Grade 0 Extended (-50°C to 160°C)	±1.3°C	±2.3°C	10°C
LM57FEPWQ1, LM57FEPWRQ1 <sup>(1)</sup>	PW/TSSOP (8)	Automotive Grade 0 Standard (-50°C to 150°C)	±1.3°C	±2.3°C	5°C
LM57TEPWQ1, LM57TEPWRQ1 <sup>(1)</sup>	PW/TSSOP (8)	Automotive Grade 0 Standard (-50°C to 150°C)	±1.3°C	±2.3°C	10°C
LM57FQPWQ1, LM57FQPWRQ1 <sup>(1)</sup>	PW/TSSOP (8)	Automotive Grade 1 Standard (-50°C to 125°C)	±1.3°C	±2.3°C	5°C
LM57TQPWQ1, LM57TQPWRQ1 <sup>(1)</sup>	PW/TSSOP (8)	Automotive Grade 1 Standard (-50°C to 125°C)	±1.3°C	±2.3°C	10°C

(1) For Automotive grade device complete datasheet see [LM57-Q1](#).

## 6 Pin Configuration and Functions

TSSOP/PW and WSON/SD/NGR/DFN Packages  
8-Pin  
Top View

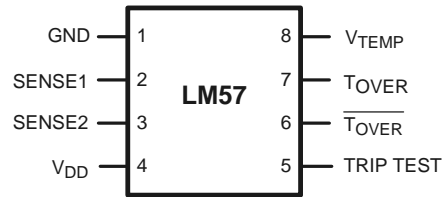

Pin Functions

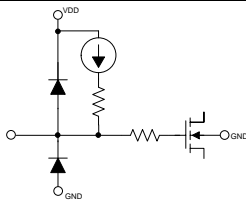
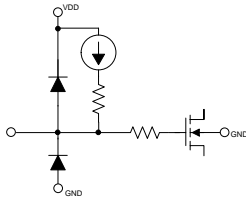
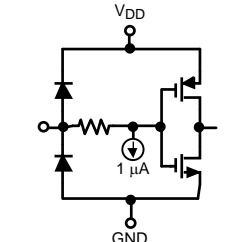
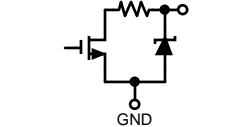
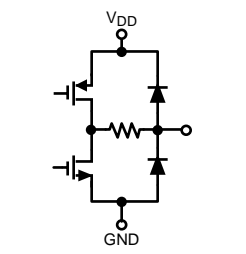
PIN		TYPE	EQUIVALENT CIRCUIT	DESCRIPTION
NAME	NO.			
GND	1	Ground	—	Power supply ground
SENSE1	2	—		Trip-point resistor sense. One of two sense pins which selects the temperature at which $T_{OVER}$ and $\overline{T_{OVER}}$ will assert.
SENSE2	3	—		Trip-point resistor sense. One of two sense pins which selects the temperature at which $T_{OVER}$ and $\overline{T_{OVER}}$ will assert.
V <sub>DD</sub>	4	Power	—	Supply voltage
TRIP TEST	5	Digital Input		TRIP TEST pin. Active High input. If TRIP TEST = 0 (default), then the $V_{TEMP}$ output has the analog temperature sensor output voltage. If TRIP TEST = 1, then $T_{OVER}$ and $\overline{T_{OVER}}$ outputs are asserted and $V_{TEMP} = V_{TRIP}$ , the temperature trip voltage. Tie this pin to ground if not used.
$\overline{T_{OVER}}$	6	Digital Output		Overtemperature switch output Active low, open-drain (see <a href="#">LM57 V<sub>TEMP</sub> Voltage-to-Temperature Equations</a> regarding required pullup resistor.) Asserted when the measured temperature exceeds the Trip Point Temperature or if TRIP TEST = 1 This pin may be left open if not used.
$T_{OVER}$	7	Digital Output		Overtemperature switch output Active high, push-pull Asserted when the measured temperature exceeds the trip point temperature or if TRIP TEST = 1 This pin may be left open if not used.

**Pin Functions (continued)**

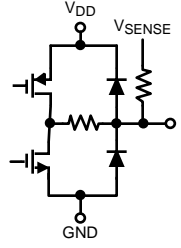
PIN		TYPE	EQUIVALENT CIRCUIT	DESCRIPTION
NAME	NO.			
V <sub>TEMP</sub>	8	Analog Output		V <sub>TEMP</sub> analog voltage output If TRIP TEST = 0, then V <sub>TEMP</sub> = V <sub>TS</sub> , temperature sensor output voltage If TRIP TEST = 1, then V <sub>TEMP</sub> = V <sub>TRIP</sub> , temperature trip voltage This pin may be left open if not used.
Thermal Pad (WSON package only)	—	—	—	Connected to GND

## 7 Specifications

### 7.1 Absolute Maximum Ratings

over operating free-air temperature range (unless otherwise noted) <sup>(1)</sup> <sup>(2)</sup>

	MIN	MAX	UNIT
Supply voltage	-0.3	6	V
Voltage at $\overline{T}_{OVER}$	-0.3	6	V
Voltage at T <sub>OVER</sub> , V <sub>TEMP</sub> , TRIP-TEST, SENSE1, and SENSE2	-0.3	(V <sub>DD</sub> + 0.3 V)	V
Current at any pin		5	mA
Storage temperature	-65	150	°C

- Stresses beyond those listed under *Absolute Maximum Ratings* may cause permanent damage to the device. These are stress ratings only, which do not imply functional operation of the device at these or any other conditions beyond those indicated under *Recommended Operating Conditions*. Exposure to absolute-maximum-rated conditions for extended periods may affect device reliability.
- Soldering process must comply with Reflow Temperature Profile specifications. Refer to [www.ti.com/packaging](http://www.ti.com/packaging).

### 7.2 ESD Ratings

		VALUE	UNIT
LM57BISD and LM57CISD in WSON package			
V <sub>(ESD)</sub>	Electrostatic discharge <sup>(1)</sup>	Human body model (HBM)	±5500
		Charged-device model (CDM)	±1250
		Machine Model (MM)	±450
LM57FPW and LM57TPW in TSSOP package			
V <sub>(ESD)</sub>	Electrostatic discharge	Human body model (HBM), per ANSI/ESDA/JEDEC JS-001 <sup>(2)</sup>	±2000
		Charged-device model (CDM), per JEDEC specification JESD22-C101 <sup>(3)</sup>	±750

- The Human Body Model (HBM) is a 100-pF capacitor charged to the specified voltage then discharged through a 1.5-kΩ resistor into each pin. The Machine Model (MM) is a 200 pF capacitor charged to the specified voltage then discharged directly into each pin. The Charged Device Model (CDM) is a specified circuit characterizing an ESD event that occurs when a device acquires charge through some triboelectric (frictional) or electrostatic induction processes and then abruptly touches a grounded object or surface.
- JEDEC document JEP155 states that 500-V HBM allows safe manufacturing with a standard ESD control process.
- JEDEC document JEP157 states that 250-V CDM allows safe manufacturing with a standard ESD control process.

### 7.3 Recommended Operating Conditions

	MIN	NOM	MAX	UNIT
Supply voltage	2.4		5.5	V
Free air temperature range (T <sub>MIN</sub> ≤ T <sub>A</sub> ≤ T <sub>MAX</sub> )	-50		150	°C

## 7.4 Thermal Information

THERMAL METRIC <sup>(1)</sup>		LM57		UNIT
		NGR (WSON/SD)	PW (TSSOP)	
		8 PINS	8 PINS	
$R_{\theta JA}$	Junction-to-ambient thermal resistance	71.3	183	°C/W
$R_{\theta JC(top)}$	Junction-to-case (top) thermal resistance	82.8	66	°C/W
$R_{\theta JB}$	Junction-to-board thermal resistance	43.4	111	°C/W
$\Psi_{JT}$	Junction-to-top characterization parameter	2.2	8	°C/W
$\Psi_{JB}$	Junction-to-board characterization parameter	43.7	110	°C/W
$R_{\theta JC(bot)}$	Junction-to-case (bottom) thermal resistance	11.9	—	°C/W

- (1) For more information about traditional and new thermal metrics, see the *Semiconductor and IC Package Thermal Metrics* application report, [SPRA953](#).

## 7.5 Electrical Characteristics - Accuracy Characteristics – Trip Point Accuracy

PARAMETER	TEST CONDITIONS		LM57B			LM57C, LM57F or LM57T			UNIT
			MIN	TYP	MAX	MIN	TYP	MAX	
Trip Point Accuracy (Includes 1% set-resistor tolerance) (1)	J2	T <sub>A</sub> = -41°C to 52°C	V <sub>DD</sub> = 2.4 V to 5.5 V		±1.5	±2.3		°C	
	J3	T <sub>A</sub> = 52°C to 97°C	V <sub>DD</sub> = 2.4 V to 5.5 V		±1.5	±2.3		°C	
	J4	T <sub>A</sub> = 97°C to 119°C	V <sub>DD</sub> = 2.4 V to 5.5 V		±1.5	±2.3		°C	
	J5	T <sub>A</sub> = 119°C to free air temperature max	V <sub>DD</sub> = 2.4 V to 5.5 V		±1.5	±2.3		°C	

(1) Accuracy is defined as the error between the measured and reference output voltages, tabulated in the Conversion Table at the specified conditions of supply gain setting, voltage, and temperature (expressed in °C). Accuracy limits include line regulation within the specified conditions. Accuracy limits do not include load regulation; they assume no DC load.

## 7.6 Electrical Characteristics - Accuracy Characteristics – V<sub>TEMP</sub> Analog Temperature Sensor Output Accuracy

These limits do not include DC load regulation. These stated accuracy limits are with reference to the values in [Table 1](#).

PARAMETER	TEST CONDITIONS		LM57B			LM57C, LM57F or LM57T			UNIT
			MIN	TYP	MAX	MIN	TYP	MAX	
V <sub>TEMP</sub> Accuracy (These stated accuracy limits are with reference to the values in <a href="#">Table 1</a> , LM57 V <sub>TEMP</sub> Temperature-to-Voltage.) <sup>(1)</sup>	J2	T <sub>A</sub> = -50°C to free air temperature max	V <sub>DD</sub> = 2.4 V to 5.5 V		±0.95	±1.3		°C	
	J3	T <sub>A</sub> = -50°C to free air temperature max	V <sub>DD</sub> = 2.4 V to 5.5 V		±0.8	±1.3		°C	
	J4	T <sub>A</sub> = 20°C to 50°C	V <sub>DD</sub> = 2.4 V to 5.5 V		±0.7	±1.3		°C	
		T <sub>A</sub> = 0°C to free air temperature max	V <sub>DD</sub> = 2.7 V to 5.5 V		±0.7	±1.3			
		T <sub>A</sub> = -50°C to 0°C	V <sub>DD</sub> = 3.1 V to 5.5 V		±0.8	±1.3			
	J5	T <sub>A</sub> = 60°C to free air temperature max	V <sub>DD</sub> = 2.4 V to 5.5 V		±0.7	±1.3		°C	
		T <sub>A</sub> = 20°C to 50°C	V <sub>DD</sub> = 2.9 V to 5.5 V		±0.7	±1.3			
		T <sub>A</sub> = 0°C to free air temperature max	V <sub>DD</sub> = 3.2 V to 5.5 V		±0.7	±1.3			
		T <sub>A</sub> = -50°C to 0°C	V <sub>DD</sub> = 4 V to 5.5 V		±0.8	±1.3			

(1) Accuracy is defined as the error between the measured and reference output voltages, tabulated in the Conversion Table at the specified conditions of supply gain setting, voltage, and temperature (expressed in °C). Accuracy limits include line regulation within the specified conditions. Accuracy limits do not include load regulation; they assume no DC load.

## 7.7 Electrical Characteristics

Unless otherwise noted, these specifications apply for  $V_{DD} = 2.4$  to  $5.5$  V. Limits apply over free air temperature range.

PARAMETER	TEST CONDITIONS	MIN <sup>(1)</sup>	TYP <sup>(2)</sup>	MAX <sup>(1)</sup>	UNIT
<b>TEMPERATURE SENSOR</b>					
$V_{TEMP}$ sensor gain	J2: $-50^{\circ}\text{C}$ to $52^{\circ}\text{C}$		-5.166		mV/ $^{\circ}\text{C}$
	J3: $52^{\circ}\text{C}$ to $97^{\circ}\text{C}$		-7.752		
	J4: $97^{\circ}\text{C}$ to $119^{\circ}\text{C}$		-10.339		
	J5: $119^{\circ}\text{C}$ to $150^{\circ}\text{C}$		-12.924		
Line regulation DC: supply-to- $V_{TEMP}$ <sup>(3)</sup>	$V_{DD} = 2.4$ V to $5.5$ V Temp = $90^{\circ}\text{C}$		0.18		mV
			58		$\mu\text{V}/\text{V}$
			-84		dB
Load regulation: $V_{TEMP}$ output <sup>(4)</sup>	Source $\leq 240$ $\mu\text{A}$ , $(V_{DD} - V_{TEMP}) \geq 200$ mV; $T_A = -50^{\circ}\text{C}$ to $150^{\circ}\text{C}$			-1	mV
	Sink $\leq 300$ $\mu\text{A}$ , $V_{TEMP} \geq 360$ mV; $T_A = -50^{\circ}\text{C}$ to $150^{\circ}\text{C}$			1	
	Source or sink = $100$ $\mu\text{A}$ ; $T_A = -50^{\circ}\text{C}$ to $150^{\circ}\text{C}$			1	$\Omega$
Maximum Load capacitance: $V_{TEMP}$ output	No output series resistor required; (See <a href="#">V<sub>TEMP</sub> Capacitive Loads</a> )			1100	pF
$I_S$ Supply current: quiescent <sup>(5)</sup>			24	28	$\mu\text{A}$
<b>TRIP-TEST INPUT</b>					
$V_{IH}$ Logic 1 threshold voltage		$V_{DD} - 0.5$			V
$V_{IL}$ Logic 0 threshold voltage				0.5	V
$I_{IH}$ Logic 1 input current			1.4	3	$\mu\text{A}$
$I_{IL}$ Logic 0 input leakage current <sup>(6)</sup>	$T_A = -50^{\circ}\text{C}$ to $150^{\circ}\text{C}$		0.001	1	$\mu\text{A}$
<b>T<sub>OVER</sub> (PUSH-PULL, ACTIVE-HIGH) OUTPUT</b>					
$V_{OH}$ Logic 1 push-pull output voltage	Source $\leq 600$ $\mu\text{A}$	$V_{DD} - 0.2$			V
	Source $\leq 1.2$ mA	$V_{DD} - 0.45$			
$V_{OL}$ Logic 0 output voltage	Sink $\leq 600$ $\mu\text{A}$			0.2	V
	Sink $\leq 1.2$ mA			0.45	
<b>T<sub>OVER</sub> (OPEN-DRAIN, ACTIVE-LOW) OUTPUT</b>					
$V_{OL}$ Logic 0 output voltage	Sink $\leq 600$ $\mu\text{A}$			0.2	V
	Sink $\leq 1.2$ mA			0.45	
$I_{OH}$ Logic 1 output leakage current <sup>(6)</sup>	Temperature = $30^{\circ}\text{C}$ ;		0.001	1	$\mu\text{A}$

- (1) Limits are specified to TI's average outgoing quality level (AOQL).
- (2) Typicals are at  $T_J = T_A = 25^{\circ}\text{C}$  and represent most likely parametric norm.
- (3) Line regulation (DC) is calculated by subtracting the output voltage at the highest supply voltage from the output voltage at the lowest supply voltage. The typical DC line regulation specification does not include the output voltage shift discussed in [V<sub>TEMP</sub> Voltage Shift](#).
- (4) Source currents are flowing out of the LM57. Sink currents are flowing into the LM57. Load Regulation is calculated by measuring  $V_{TEMP}$  at  $0$   $\mu\text{A}$  and subtracting the value with the conditions specified.
- (5) Supply current refers to the quiescent current of the LM57 only and does not include any load current.
- (6) This current is leakage current only and is therefore highest at high temperatures. Prototype test indicate that the leakage is well below  $1$   $\mu\text{A}$  over the full temperature range. This  $1$   $\mu\text{A}$  specification reflects the limitations of measuring leakage at room temperature. For this reason only, the leakage current is not specified at a lower value.

## Electrical Characteristics (continued)

Unless otherwise noted, these specifications apply for  $V_{DD} = 2.4$  to  $5.5$  V. Limits apply over free air temperature range.

PARAMETER	TEST CONDITIONS	MIN <sup>(1)</sup>	TYP <sup>(2)</sup>	MAX <sup>(1)</sup>	UNIT
<b>HYSTERESIS</b>					
$T_{HYST}$ Hysteresis temperature	5°C hysteresis option (for all LM57F or LM57-5)	4.7	5	5.4	°C
	10°C hysteresis option (for all LM57T or LM57-10)	9.6	10	10.6	°C

## 7.8 Switching Characteristics

Unless otherwise noted, these specifications apply for  $V_{DD} = 2.4$  to  $5.5$  V over the free air temperature range.

PARAMETER	TEST CONDITIONS	MIN	TYP	MAX	UNIT
$t_{EN}$	Maximum time from power on to digital output enabled		1.5	2.9	ms
$t_{VTEMP}$	Maximum time from power on to analog temperature ( $V_{TEMP}$ ) valid		1.5	2.9	ms

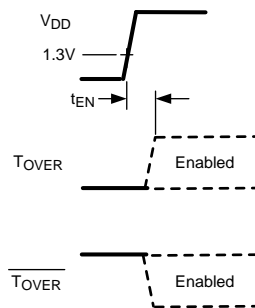

Figure 1. Definition of  $t_{EN}$

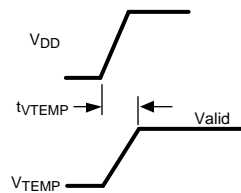

Figure 2. Definition of  $t_{VTEMP}$

### 7.9 Typical Characteristics

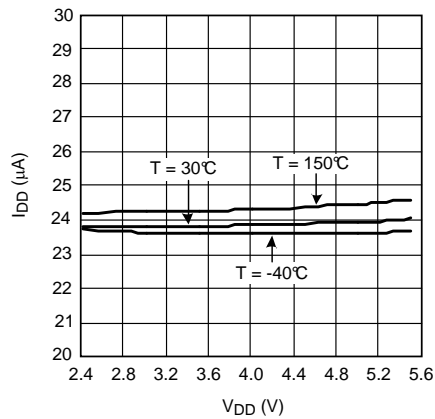

Figure 3. Supply Current vs Supply Voltage

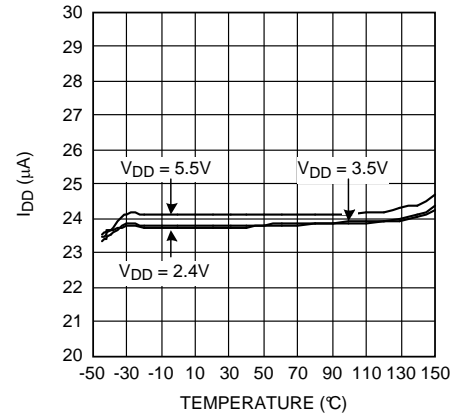

Figure 4. Supply Current vs Temperature

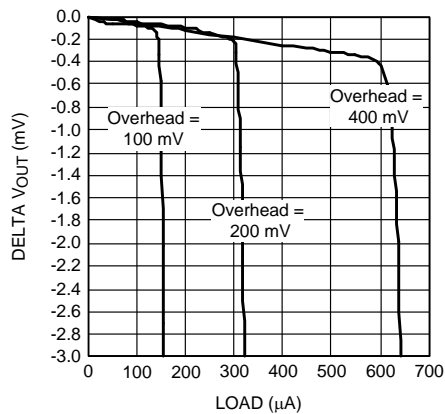

Figure 5. Load Regulation: Change In  $V_{TEMP}$  vs Source Current Overhead Is  $V_{DD}-V_{TEMP}$

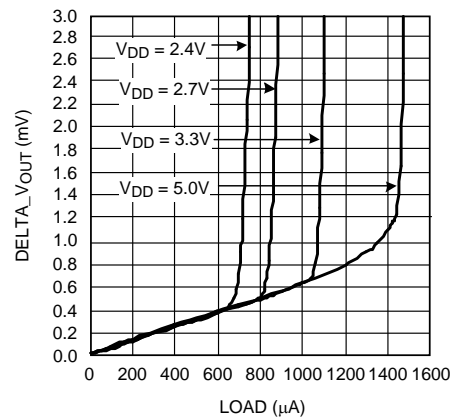

Figure 6. Load Regulation: Change In  $V_{TEMP}$  vs Sink Current

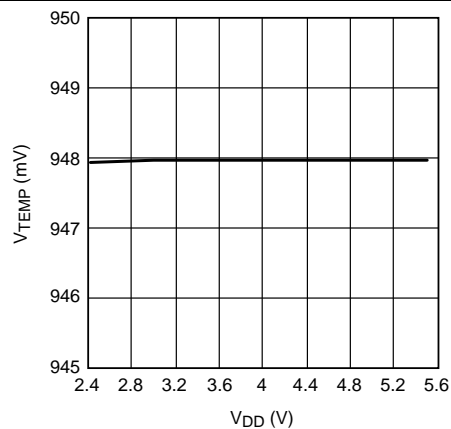

Figure 7. Line Regulation:  $V_{TEMP}$  vs Supply Voltage

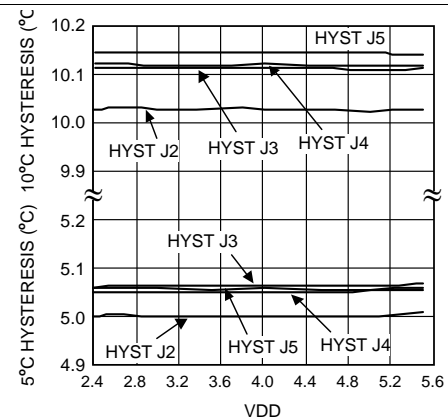

Figure 8. Line Regulation: Hysteresis vs Supply Voltage 30°C

Typical Characteristics (continued)

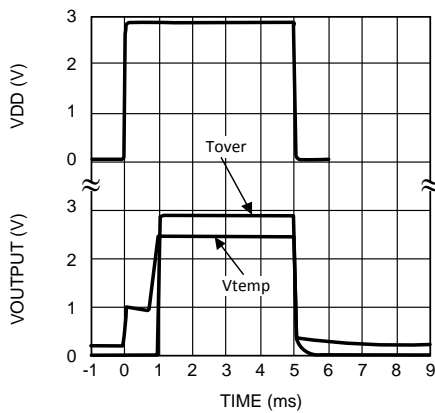

Figure 9. Start-Up Response

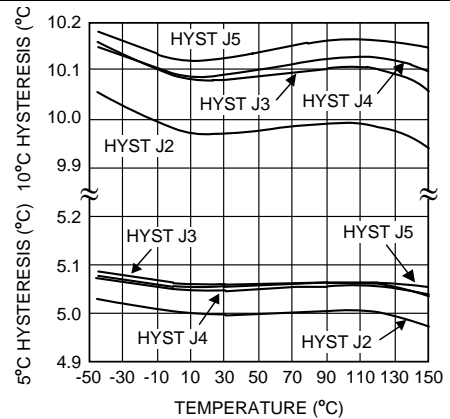

Figure 10. Hysteresis vs Temperature

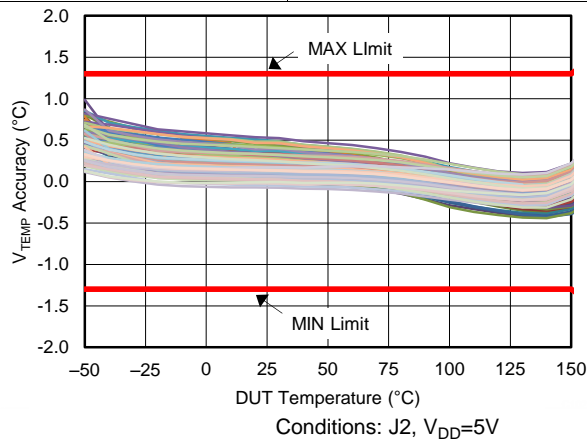

Figure 11. J2 Accuracy Specification Over Temperature

## 8 Detailed Description

### 8.1 Overview

The LM57 is a precision, dual-output, temperature switch with analog temperature sensor output. The trip temperature ( $T_{TRIP}$ ) is selected from 256 possible values by using two external 1% resistors. The  $V_{TEMP}$  class AB analog output provides a voltage that is proportional to temperature. The LM57 includes an internal reference DAC, analog temperature sensor and analog comparator. The reference DAC is connected to one of the comparator inputs. The reference DAC output voltage ( $V_{TRIP}$ ) is controlled by the value of resistance applied to the SENSE pins. The resistance value sets one of 16 "logic" levels at the SENSE pins. These "logic" levels are then decoded and applied to the DAC input, thus the actual resistance tolerance does not directly affect the threshold level accuracy. The result of the reference DAC voltage and the temperature sensor output comparison is provided on two output pins  $\overline{T_{OVER}}$  and  $T_{OVER}$ .

The  $V_{TEMP}$  output has a programmable gain. The output gain has 4 possible settings as described in [Figure 12](#). The gain setting is dependent on the trip point selected by resistance applied to the SENSE pins.

Built-in temperature hysteresis ( $T_{HYST}$ ) prevents the digital outputs from oscillating. The  $T_{OVER}$  and  $\overline{T_{OVER}}$  will activate when the die temperature exceeds  $T_{TRIP}$  and will release when the temperature falls below a temperature equal to  $T_{TRIP}$  minus  $T_{HYST}$ .  $T_{OVER}$  is active-high with a push-pull structure.  $\overline{T_{OVER}}$ , is active-low with an open-drain structure. There are two different hysteresis options available that are factory preset. The preset hysteresis can be selected by purchasing the proper order number as described in [Device Comparison Table](#).

Driving the TRIP-TEST high will activate the digital outputs. A processor can check the logic level of the  $T_{OVER}$  or  $\overline{T_{OVER}}$ , confirming that they changed to their active state. This allows for system production testing verification that the comparator and output circuitry are functional after system assembly. When the TRIP-TEST pin is high, the trip-level reference voltage appears at the  $V_{TEMP}$  pin. Tying  $T_{OVER}$  to TRIP-TEST will latch the output after it trips. It can be cleared by forcing TRIP-TEST low or powering off the LM57.

### 8.2 Functional Block Diagram

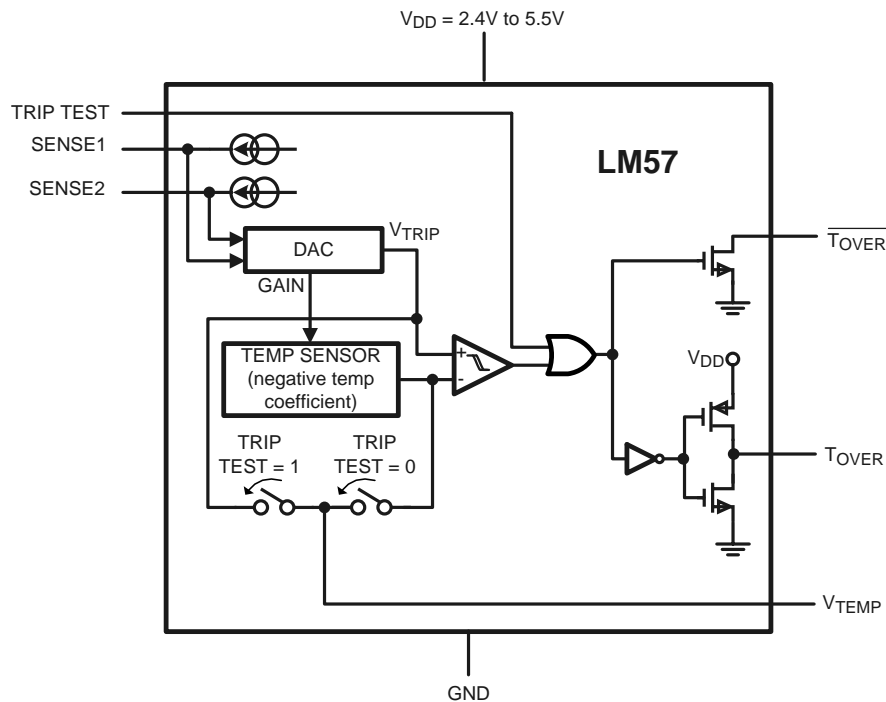

## 8.3 Feature Description

### 8.3.1 LM57 $V_{TEMP}$ Temperature-to-Voltage Transfer Function

The value of the  $R_{SENSE}$  resistors select a trip point and a corresponding  $V_{TEMP}$  gain (J2, J3, J4, or J5). The trip point range associated with a given gain is shown in bold green in Table 1. The  $V_{TEMP}$  gain is selected by the  $R_{SENSE}$  resistors.  $V_{TEMP}$  is valid over the entire temperature range. The  $V_{TEMP}$  gain is selected by the  $R_{SENSE}$  resistors.  $V_{TEMP}$  is valid over the entire temperature range.

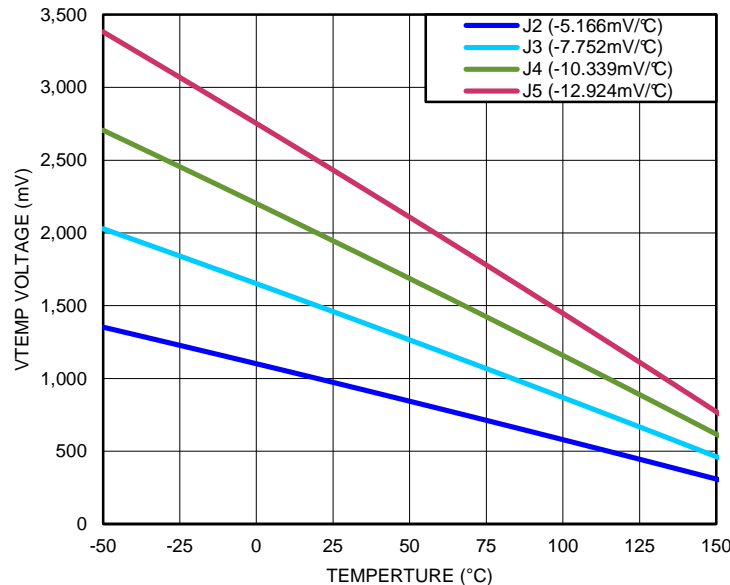

Figure 12. Temperature Transfer Characteristics

Table 1. LM57  $V_{TEMP}$  Temperature to Voltage <sup>(1)</sup>

Temperature (°C)	$V_{TEMP}$ VOLTAGE (mV)			
	J2 (-5.166 mV/°C)	J3 (-7.752 mV/°C)	J4 (-10.339 mV/°C)	J5 (-12.924 mV/°C)
-50	1352.56	2028.80	2705.20	3381.40
-49	1347.60	2021.35	2695.26	3368.98
-48	1342.64	2013.90	2685.32	3356.55
-47	1337.67	2006.44	2675.38	3344.12
-46	1332.70	1998.98	2665.43	3331.68
-45	1327.73	1991.52	2655.47	3319.23
-44	1322.76	1984.05	2645.51	3306.78
-43	1317.78	1976.58	2635.54	3294.32
-42	1312.81	1969.11	2625.57	3281.85
-41	<b>1307.82</b>	1961.63	2615.60	3269.38
-40	<b>1302.84</b>	1954.15	2605.62	3256.90
-39	<b>1297.86</b>	1946.66	2595.63	3244.41
-38	<b>1292.87</b>	1939.17	2585.64	3231.92
-37	<b>1287.88</b>	1931.68	2575.64	3219.42
-36	<b>1282.88</b>	1924.18	2565.64	3206.92
-35	<b>1277.89</b>	1916.68	2555.63	3194.41
-34	<b>1272.89</b>	1909.17	2545.62	3181.89

(1) The  $R_{SENSE}$  resistors select a trip point and a corresponding  $V_{TEMP}$  gain (J2, J3, J4, or J5). The trip point range associated with a given gain is shown in bold green on this table.  $V_{TEMP}$  is valid over the entire temperature range.

**Feature Description (continued)**
**Table 1. LM57  $V_{TEMP}$  Temperature to Voltage <sup>(1)</sup> (continued)**

Temperature (°C)	$V_{TEMP}$ VOLTAGE (mV)			
	J2 (-5.166 mV/°C)	J3 (-7.752 mV/°C)	J4 (-10.339 mV/°C)	J5 (-12.924 mV/°C)
-33	<b>1267.88</b>	1901.66	2535.60	3169.37
-32	<b>1262.88</b>	1894.15	2525.58	3156.84
-31	<b>1257.87</b>	1886.63	2515.56	3144.30
-30	<b>1252.86</b>	1879.11	2505.52	3131.76
-29	<b>1247.85</b>	1871.59	2495.49	3119.21
-28	<b>1242.84</b>	1864.06	2485.44	3106.66
-27	<b>1237.82</b>	1856.53	2475.40	3094.10
-26	<b>1232.80</b>	1848.99	2465.34	3081.53
-25	<b>1227.78</b>	1841.45	2455.29	3068.96
-24	<b>1222.75</b>	1833.91	2445.23	3056.38
-23	<b>1217.73</b>	1826.36	2435.16	3043.79
-22	<b>1212.70</b>	1818.81	2425.09	3031.20
-21	<b>1207.67</b>	1811.26	2415.01	3018.60
-20	<b>1202.63</b>	1803.70	2404.93	3006.00
-19	<b>1197.59</b>	1796.13	2394.84	2993.38
-18	<b>1192.55</b>	1788.57	2384.74	2980.77
-17	<b>1187.51</b>	1781.00	2374.65	2968.14
-16	<b>1182.46</b>	1773.42	2364.54	2955.51
-15	<b>1177.42</b>	1765.85	2354.44	2942.87
-14	<b>1172.37</b>	1758.26	2344.32	2930.23
-13	<b>1167.31</b>	1750.68	2334.20	2917.58
-12	<b>1162.26</b>	1743.09	2324.08	2904.93
-11	<b>1157.20</b>	1735.50	2313.95	2892.26
-10	<b>1152.14</b>	1727.90	2303.82	2879.60
-9	<b>1147.07</b>	1720.30	2293.68	2866.92
-8	<b>1142.01</b>	1712.69	2283.54	2854.24
-7	<b>1136.94</b>	1705.09	2273.39	2841.55
-6	<b>1131.87</b>	1697.47	2263.24	2828.86
-5	<b>1126.79</b>	1689.86	2253.08	2816.16
-4	<b>1121.72</b>	1682.24	2242.91	2803.45
-3	<b>1116.64</b>	1674.61	2232.74	2790.74
-2	<b>1111.56</b>	1666.99	2222.57	2778.02
-1	<b>1106.47</b>	1659.35	2212.39	2765.30
0	<b>1101.39</b>	1651.72	2202.21	2752.57
1	<b>1096.30</b>	1644.08	2192.02	2739.83
2	<b>1091.20</b>	1636.44	2181.82	2727.08
3	<b>1086.11</b>	1628.79	2171.62	2714.33
4	<b>1081.01</b>	1621.14	2161.42	2701.58
5	<b>1075.91</b>	1613.48	2151.21	2688.82
6	<b>1070.81</b>	1605.83	2141.00	2676.05
7	<b>1065.71</b>	1598.16	2130.78	2663.27
8	<b>1060.60</b>	1590.50	2120.55	2650.49
9	<b>1055.49</b>	1582.83	2110.32	2637.70
10	<b>1050.38</b>	1575.15	2100.09	2624.91
11	<b>1045.26</b>	1567.48	2089.85	2612.10

**Feature Description (continued)**
**Table 1. LM57 V<sub>TEMP</sub> Temperature to Voltage <sup>(1)</sup> (continued)**

Temperature (°C)	V <sub>TEMP</sub> VOLTAGE (mV)			
	J2 (-5.166 mV/°C)	J3 (-7.752 mV/°C)	J4 (-10.339 mV/°C)	J5 (-12.924 mV/°C)
12	<b>1040.14</b>	1559.80	2079.60	2599.30
13	<b>1035.02</b>	1552.11	2069.35	2586.48
14	<b>1029.90</b>	1544.42	2059.10	2573.66
15	<b>1024.77</b>	1536.73	2048.84	2560.84
16	<b>1019.65</b>	1529.03	2038.57	2548.01
17	<b>1014.51</b>	1521.33	2028.30	2535.17
18	<b>1009.38</b>	1513.63	2018.03	2522.32
19	<b>1004.25</b>	1505.92	2007.75	2509.47
20	<b>999.11</b>	1498.21	1997.46	2496.61
21	<b>993.97</b>	1490.49	1987.17	2483.75
22	<b>988.82</b>	1482.77	1976.88	2470.88
23	<b>983.68</b>	1475.05	1966.58	2458.00
24	<b>978.53</b>	1467.32	1956.27	2445.12
25	<b>973.38</b>	1459.59	1945.96	2432.23
26	<b>968.22</b>	1451.86	1935.64	2419.34
27	<b>963.07</b>	1444.12	1925.32	2406.43
28	<b>957.91</b>	1436.38	1915.00	2393.53
29	<b>952.74</b>	1428.63	1904.67	2380.61
30	<b>947.58</b>	1420.88	1894.33	2367.69
31	<b>942.41</b>	1413.13	1883.99	2354.76
32	<b>937.24</b>	1405.37	1873.64	2341.83
33	<b>932.07</b>	1397.61	1863.29	2328.89
34	<b>926.90</b>	1389.84	1852.94	2315.94
35	<b>921.72</b>	1382.07	1842.57	2302.99
36	<b>916.54</b>	1374.30	1832.21	2290.03
37	<b>911.36</b>	1366.52	1821.84	2277.07
38	<b>906.17</b>	1358.74	1811.46	2264.10
39	<b>900.98</b>	1350.96	1801.08	2251.12
40	<b>895.79</b>	1343.17	1790.69	2238.14
41	<b>890.60</b>	1335.38	1780.30	2225.15
42	<b>885.41</b>	1327.58	1769.90	2212.15
43	<b>880.21</b>	1319.78	1759.50	2199.15
44	<b>875.01</b>	1311.98	1749.09	2186.14
45	<b>869.81</b>	1304.17	1738.68	2173.12
46	<b>864.60</b>	1296.36	1728.26	2160.10
47	<b>859.39</b>	1288.54	1717.84	2147.07
48	<b>854.18</b>	1280.72	1707.41	2134.04
49	<b>848.97</b>	1272.90	1696.98	2121.00
50	<b>843.75</b>	1265.07	1686.54	2107.95
51	<b>838.53</b>	1257.24	1676.10	2094.90
52	<b>833.31</b>	1249.41	1665.65	2081.84
53	828.09	<b>1241.57</b>	1655.20	2068.77
54	822.86	<b>1233.73</b>	1644.74	2055.70
55	817.63	<b>1225.88</b>	1634.28	2042.62
56	812.40	<b>1218.03</b>	1623.81	2029.54

**Feature Description (continued)**
**Table 1. LM57 V<sub>TEMP</sub> Temperature to Voltage <sup>(1)</sup> (continued)**

Temperature (°C)	V <sub>TEMP</sub> VOLTAGE (mV)			
	J2 (-5.166 mV/°C)	J3 (-7.752 mV/°C)	J4 (-10.339 mV/°C)	J5 (-12.924 mV/°C)
57	807.17	<b>1210.18</b>	1613.34	2016.44
58	801.93	<b>1202.32</b>	1602.86	2003.35
59	796.69	<b>1194.46</b>	1592.38	1990.24
60	791.45	<b>1186.60</b>	1581.89	1977.13
61	786.20	<b>1178.73</b>	1571.40	1964.02
62	780.96	<b>1170.86</b>	1560.90	1950.89
63	775.71	<b>1162.98</b>	1550.40	1937.76
64	770.46	<b>1155.10</b>	1539.89	1924.63
65	765.20	<b>1147.22</b>	1529.37	1911.49
66	759.94	<b>1139.33</b>	1518.86	1898.34
67	754.68	<b>1131.44</b>	1508.33	1885.19
68	749.42	<b>1123.54</b>	1497.80	1872.02
69	744.16	<b>1115.64</b>	1487.27	1858.86
70	738.89	<b>1107.74</b>	1476.73	1845.68
71	733.62	<b>1099.83</b>	1466.19	1832.50
72	728.35	<b>1091.92</b>	1455.64	1819.32
73	723.07	<b>1084.01</b>	1445.08	1806.13
74	717.79	<b>1076.09</b>	1434.53	1792.93
75	712.51	<b>1068.17</b>	1423.96	1779.72
76	707.23	<b>1060.24</b>	1413.39	1766.51
77	701.94	<b>1052.31</b>	1402.82	1753.30
78	696.65	<b>1044.38</b>	1392.24	1740.07
79	691.36	<b>1036.44</b>	1381.65	1726.84
80	686.07	<b>1028.50</b>	1371.07	1713.61
81	680.77	<b>1020.55</b>	1360.47	1700.36
82	675.48	<b>1012.60</b>	1349.87	1687.11
83	670.17	<b>1004.65</b>	1339.27	1673.86
84	664.87	<b>996.69</b>	1328.66	1660.60
85	659.56	<b>988.73</b>	1318.04	1647.33
86	654.25	<b>980.77</b>	1307.42	1634.05
87	648.94	<b>972.80</b>	1296.80	1620.77
88	643.63	<b>964.83</b>	1286.17	1607.49
89	638.31	<b>956.85</b>	1275.53	1594.19
90	632.99	<b>948.87</b>	1264.89	1580.89
91	627.67	<b>940.89</b>	1254.25	1567.59
92	622.35	<b>932.90</b>	1243.60	1554.28
93	617.02	<b>924.91</b>	1232.94	1540.96
94	611.69	<b>916.92</b>	1222.28	1527.63
95	606.36	<b>908.92</b>	1211.61	1514.30
96	601.02	<b>900.91</b>	1200.94	1500.97
97	595.69	892.91	<b>1190.27</b>	1487.62
98	590.34	884.90	<b>1179.59</b>	1474.27
99	585.00	876.88	<b>1168.90</b>	1460.92
100	579.66	868.87	<b>1158.21</b>	1447.55
101	574.31	860.84	<b>1147.52</b>	1434.18

**Feature Description (continued)**
**Table 1. LM57  $V_{TEMP}$  Temperature to Voltage <sup>(1)</sup> (continued)**

Temperature (°C)	$V_{TEMP}$ VOLTAGE (mV)			
	J2 (-5.166 mV/°C)	J3 (-7.752 mV/°C)	J4 (-10.339 mV/°C)	J5 (-12.924 mV/°C)
102	568.96	852.82	<b>1136.81</b>	1420.81
103	563.61	844.79	<b>1126.11</b>	1407.43
104	558.25	836.76	<b>1115.40</b>	1394.04
105	552.89	828.72	<b>1104.68</b>	1380.65
106	547.53	820.68	<b>1093.96</b>	1367.24
107	542.17	812.63	<b>1083.23</b>	1353.84
108	536.80	804.59	<b>1072.50</b>	1340.42
109	531.43	796.53	<b>1061.77</b>	1327.01
110	526.06	788.48	<b>1051.02</b>	1313.58
111	520.69	780.42	<b>1040.28</b>	1300.15
112	515.31	772.35	<b>1029.53</b>	1286.71
113	509.93	764.29	<b>1018.77</b>	1273.26
114	504.55	756.21	<b>1008.01</b>	1259.81
115	499.17	748.14	<b>997.24</b>	1246.36
116	493.78	740.06	<b>986.47</b>	1232.89
117	488.39	731.98	<b>975.69</b>	1219.42
118	483.00	723.89	<b>964.91</b>	1205.95
119	477.61	715.80	<b>954.12</b>	1192.46
120	472.21	707.70	943.33	<b>1178.98</b>
121	466.81	699.61	932.53	<b>1165.48</b>
122	461.41	691.50	921.73	<b>1151.98</b>
123	456.00	683.40	910.92	<b>1138.47</b>
124	450.60	675.29	900.11	<b>1124.96</b>
125	445.19	667.18	889.29	<b>1111.44</b>
126	439.78	659.06	878.47	<b>1097.91</b>
127	434.36	650.94	867.64	<b>1084.38</b>
128	428.94	642.81	856.81	<b>1070.84</b>
129	423.52	634.68	845.97	<b>1057.29</b>
130	418.10	626.55	835.13	<b>1043.74</b>
131	412.67	618.41	824.28	<b>1030.18</b>
132	407.25	610.27	813.43	<b>1016.62</b>
133	401.82	602.13	802.57	<b>1003.05</b>
134	396.38	593.98	791.71	<b>989.47</b>
135	390.95	585.83	780.84	<b>975.89</b>
136	385.51	577.67	769.97	<b>962.30</b>
137	380.07	569.51	759.09	<b>948.70</b>
138	374.63	561.35	748.20	<b>935.10</b>
139	369.18	553.18	737.32	<b>921.49</b>
140	363.73	545.01	726.42	<b>907.87</b>
141	358.28	536.84	715.52	<b>894.25</b>
142	352.83	528.66	704.62	<b>880.62</b>
143	347.37	520.48	693.71	<b>866.99</b>
144	341.91	512.29	682.80	<b>853.35</b>
145	336.45	504.10	671.88	<b>839.70</b>
146	330.99	495.91	660.95	<b>826.05</b>

**Feature Description (continued)**
**Table 1. LM57  $V_{TEMP}$  Temperature to Voltage <sup>(1)</sup> (continued)**

Temperature (°C)	$V_{TEMP}$ VOLTAGE (mV)			
	J2 (-5.166 mV/°C)	J3 (-7.752 mV/°C)	J4 (-10.339 mV/°C)	J5 (-12.924 mV/°C)
147	325.52	487.71	650.03	<b>812.39</b>
148	320.05	479.51	639.09	<b>798.73</b>
149	314.58	471.30	628.15	<b>785.05</b>
150	309.10	463.09	617.21	<b>771.38</b>

### 8.3.1.1 LM57 $V_{TEMP}$ Voltage-to-Temperature Equations

$$V_{TEMP} = a (T-30)^2 + b (T-30) + c$$

where

- $V_{TEMP}$  is in mV and T is in °C

(1)

$$T = \frac{-b - \sqrt{b^2 - 4a(c - V_{TEMP})}}{2a} + 30^\circ\text{C}$$

where

- T is in °C and  $V_{TEMP}$  is in mV

(2)

**Table 2. LM57  $V_{TEMP}$  Voltage-to-Temperature Equations Coefficients**

Trip-Point Region	LM57 Trip Point Range	a	b	c
J2	-41°C to 52°C	- 0.00129	- 5.166	947.6
J3	52°C to 97°C	- 0.00191	- 7.752	1420.9
J4	97°C to 119°C	- 0.00253	- 10.339	1894.3
J5	119°C to 150°C	- 0.00316	- 12.924	2367.7

### 8.3.2 $R_{SENSE}$

The LM57 uses the voltage at the two SENSE pins to set the trip point for the temperature switch. It is possible to drive the two SENSE pins with a voltage equal to the value generated by the resistor and the internal current-source and have the same switch point. Thus one can use an external DAC to drive each SENSE pin, allowing for the temperature trip point to be set dynamically by the system processor. [Table 3](#) shows the  $R_{SENSE}$  value and its corresponding generated SENSE pin voltage (the center value).

**Table 3.  $R_{SENSE}$  Values (k $\Omega$ ) vs SENSE Pin Voltage (mV)**

$R_{SENSE}$ (k $\Omega$ )	SENSE Pin Voltage (mV)
	Center Value
976	1875
825	1585
698	1341
590	1134
499	959
412	792
340	653
280	538
226	434
178	342
140	269
105	202
75	146
46.4	87
22.6	43
0.01	0

**8.3.3 Resistor Selection**
**Table 4. Trip Point (°C) vs Sense Resistor ( $R_{SENSE}$ ) Values ( $\Omega$ )**

		$R_{SENSE2}$												
		J2 <sup>(1)</sup>				J3 <sup>(1)</sup>			J4 <sup>(1)</sup>		J5 <sup>(1)</sup>			
		976 k $\Omega$	825 k $\Omega$	698 k $\Omega$	590 k $\Omega$	499 k $\Omega$	412 k $\Omega$	340 k $\Omega$	280 k $\Omega$	226 k $\Omega$	178 k $\Omega$	140 k $\Omega$	105 k $\Omega$	75 k $\Omega$
$R_{SENSE1}$	976 k $\Omega$	-40.68	-16.26	7.33	30.38	52.73	67.77	82.74	97.47	108.61	119.62	128.46	137.28	146.08
	825 k $\Omega$	-39.13	-14.76	8.79	31.81	53.68	68.71	83.67	98.17	109.30	120.18	129.01	137.83	146.62
	698 k $\Omega$	-37.57	-13.27	10.24	33.24	54.62	69.65	84.60	98.86	110.00	120.73	129.56	138.38	147.16
	590 k $\Omega$	-36.03	-11.78	11.70	34.67	55.56	70.59	85.53	99.56	110.70	121.28	130.12	138.93	147.71
	499 k $\Omega$	-34.49	-10.29	13.15	36.10	56.50	71.52	86.46	100.25	111.39	121.84	130.67	139.49	148.25
	412 k $\Omega$	-32.95	-8.81	14.60	37.53	57.44	72.46	87.40	100.95	112.09	122.39	131.22	140.04	148.80
	340 k $\Omega$	-31.41	-7.32	16.05	38.95	58.39	73.40	88.33	101.64	112.79	122.94	131.77	140.59	149.34
	280 k $\Omega$	-29.88	-5.83	17.49	40.38	59.33	74.33	89.26	102.34	113.48	123.50	132.32	141.14	149.88
	226 k $\Omega$	-28.34	-4.35	18.93	41.81	60.27	75.27	90.19	103.03	114.18	124.05	132.87	141.69	150.43
	178 k $\Omega$	-26.83	-2.88	20.36	43.23	61.21	76.20	91.12	103.73	114.87	124.60	133.43	142.24	
	140 k $\Omega$	-25.32	-1.42	21.79	44.65	62.15	77.14	92.05	104.42	115.57	125.15	133.98	142.79	
	105 k $\Omega$	-23.80	0.04	23.22	46.07	63.08	78.07	92.99	105.11	116.26	125.71	134.53	143.34	
	75 k $\Omega$	-22.29	1.50	24.65	47.50	64.02	79.01	93.92	105.81	116.95	126.26	135.08	143.89	
	46.4 k $\Omega$	-20.77	2.96	26.08	48.92	64.96	79.94	94.84	106.50	117.65	126.81	135.63	144.44	
22.6 k $\Omega$	-19.26	4.42	27.51	50.33	65.90	80.87	95.77	107.19	118.34	127.36	136.18	144.99		
0.01 k $\Omega$	-17.75	5.88	28.94	51.75	66.84	81.81	96.70	107.89	119.04	127.91	136.73	145.54		

- (1) There are four gains corresponding to each of the four Temperature Trip Point Ranges:
- J2 (-5.166 mV/°C) is the temperature sensor output gain used for Temperature Trip Points -40.68°C to 51.8°C.
  - J3 (-7.752 mV/°C) is for Trip Points 52°C to 97°C.
  - J4 (-10.339 mV/°C) for 97°C to 119°C.
  - J5 (-12.924 mV/°C) for 119°C to 150°C.

**Table 5.  $V_{TEMP}$  (mV) at the Trip Point vs Sense Resistor ( $R_{SENSE}$ ) Value ( $\Omega$ )**

		$R_{SENSE2}$												
		J2 <sup>(1)</sup>				J3 <sup>(1)</sup>			J4 <sup>(1)</sup>		J5 <sup>(1)</sup>			
		976 k $\Omega$	825 k $\Omega$	698 k $\Omega$	590 k $\Omega$	499 k $\Omega$	412 k $\Omega$	340 k $\Omega$	280 k $\Omega$	226 k $\Omega$	178 k $\Omega$	140 k $\Omega$	105 k $\Omega$	75 k $\Omega$
$R_{SENSE1}$	976 k $\Omega$	1306.23	1183.77	1064.00	945.63	1243.67	1125.34	1006.75	1185.27	1066.00	1184.05	1064.59	944.83	824.96
	825 k $\Omega$	1298.50	1176.23	1056.56	938.23	1236.27	1117.93	999.34	1177.83	1058.52	1176.57	1057.10	937.33	817.53
	698 k $\Omega$	1290.72	1168.70	1049.13	930.83	1228.88	1110.52	991.92	1170.40	1051.03	1169.10	1049.62	929.83	810.09
	590 k $\Omega$	1283.03	1161.16	1041.69	923.43	1221.48	1103.10	984.51	1162.96	1043.55	1161.63	1042.13	922.33	802.66
	499 k $\Omega$	1275.33	1153.62	1034.26	916.02	1214.09	1095.69	977.09	1155.52	1036.07	1154.16	1034.65	914.83	795.22
	412 k $\Omega$	1267.64	1146.09	1026.82	908.62	1206.69	1088.28	969.66	1148.09	1028.59	1146.68	1027.16	907.33	787.78
	340 k $\Omega$	1259.94	1138.55	1019.38	901.22	1199.30	1080.87	962.22	1140.65	1021.10	1139.21	1019.67	899.83	780.35
	280 k $\Omega$	1252.25	1131.02	1011.99	893.82	1191.90	1073.45	954.78	1133.22	1013.62	1131.74	1012.19	892.33	772.91
	226 k $\Omega$	1244.55	1123.48	1004.62	886.42	1184.50	1066.04	947.35	1125.78	1006.14	1124.27	1004.70	884.83	765.48
	178 k $\Omega$	1236.99	1116.05	997.26	879.02	1177.11	1058.63	939.91	1118.35	998.66	1116.79	997.22	877.33	
	140 k $\Omega$	1229.38	1108.61	989.89	871.61	1169.71	1051.22	932.48	1110.91	991.17	1109.32	989.73	869.82	
	105 k $\Omega$	1221.76	1101.18	982.53	864.21	1162.32	1043.80	925.04	1103.48	983.69	1101.85	982.25	862.32	
	75 k $\Omega$	1214.15	1093.74	975.16	856.81	1154.92	1036.39	917.61	1096.04	976.21	1094.38	974.76	854.82	
	46.4 k $\Omega$	1206.53	1086.30	967.80	849.41	1147.53	1028.98	910.17	1088.60	968.73	1086.90	967.28	847.32	
	22.6 k $\Omega$	1198.92	1078.87	960.43	842.01	1140.13	1021.57	902.74	1081.17	961.24	1079.43	959.79	839.82	
0.01 k $\Omega$	1191.30	1071.43	953.07	834.62	1132.74	1014.15	895.30	1073.73	953.76	1072.04	952.31	832.32		

- (1) There are four gains corresponding to each of the four Temperature Trip Point Ranges:  
 J2 (-5.166 mV/°C) is the temperature sensor output gain used for Temperature Trip Points -40.68°C to 51.8°C.  
 J3 (-7.752 mV/°C) is for Trip Points 52°C to 97°C.  
 J4 (-10.339 mV/°C) for 97°C to 119°C.  
 J5 (-12.924 mV/°C) for 119°C to 150°C.

### 8.3.4 $T_{\text{OVER}}$ and $\overline{T_{\text{OVER}}}$ Digital Outputs

The  $T_{\text{OVER}}$  active high, push-pull output and the  $\overline{T_{\text{OVER}}}$  Active Low, Open-Drain Output both assert at the same time whenever the Die Temperature reaches the Trip Point. They also assert simultaneously whenever the TRIP TEST pin is set high. Both outputs de-assert when the die temperature goes below the (Temperature Trip Point) - (Hysteresis). These two types of digital outputs enable the user the flexibility to choose the type of output that is most suitable for his design.

Either the  $T_{\text{OVER}}$  or the  $\overline{T_{\text{OVER}}}$  Digital Output pins can be left open if not used.

The  $\overline{T_{\text{OVER}}}$  Active Low, Open-Drain Digital Output, if used, requires a pullup resistor between this pin and  $V_{\text{DD}}$ .

#### 8.3.4.1 $T_{\text{OVER}}$ and $\overline{T_{\text{OVER}}}$ Noise Immunity

The LM57 has some noise immunity to a premature trigger due to noise on the power supply. With the die temperature at 1°C below the trip point, there are no premature triggers for a square wave injected into the power supply with a magnitude of 100 mV<sub>PP</sub> over a frequency range of 100 Hz to 2 MHz. Above the frequency a premature trigger may occur.

With the die temperature at 2°C below the trip point, and a magnitude of 200 mV<sub>PP</sub>, there are no premature triggers from 100 Hz to 300 kHz. Above that frequency a premature trigger may occur.

Therefore if the supply line is noisy, it is recommended that a local supply decoupling capacitor be used to reduce that noise.

### 8.3.5 Trip Test Digital Input

The TRIP TEST pin provides a means to test the digital outputs by causing them to assert, regardless of temperature.

In addition, when the TRIP TEST pin is pulled high the  $V_{\text{TEMP}}$  pin will be at the  $V_{\text{TRIP}}$  voltage.

### 8.3.6 $V_{\text{TEMP}}$ Analog Temperature Sensor Output

The  $V_{\text{TEMP}}$  push-pull output provides the ability to sink and source significant current. This is beneficial when, for example, driving dynamic loads like an input stage on an analog-to-digital converter (ADC). In these applications the source current is required to quickly charge the input capacitor of the ADC. See the [Typical Application](#) section for more discussion of this topic. The LM57 is ideal for this and other applications which require strong source or sink current.

#### 8.3.6.1 $V_{\text{TEMP}}$ Noise Considerations

A load capacitor on  $V_{\text{TEMP}}$  can help to filter noise.

For noisy environments, TI recommends a 100 nF supply decoupling capacitor placed closed across  $V_{\text{DD}}$  and GND pins of LM57.

### 8.3.6.2 $V_{TEMP}$ Capacitive Loads

The  $V_{TEMP}$  Output handles capacitive loading well. In an extremely noisy environment, or when driving a switched sampling input on an ADC, it may be necessary to add some filtering to minimize noise coupling. Without any precautions, the  $V_{TEMP}$  can drive a capacitive load less than or equal to 1100 pF as shown in Figure 13. For capacitive loads greater than 1100 pF, a series resistor is required on the output, as shown in Figure 14, to maintain stable conditions.

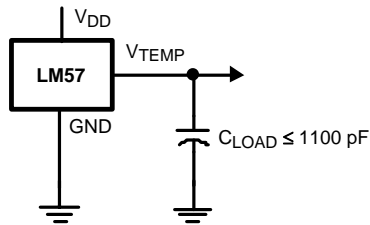

Figure 13. LM57 With No Isolation Resistor Required

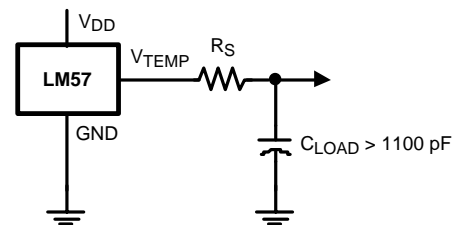

Figure 14. LM57 With Series Resistor for Capacitive Loading Greater than 1100 pF

Table 6.  $C_{LOAD}$  and  $R_S$  Values of Figure 14

$C_{LOAD}$	Minimum $R_S$
1.1 to 99 nF	3 k $\Omega$
100 to 999 nF	1.5 k $\Omega$
1 $\mu$ F	750 $\Omega$

### 8.3.6.3 $V_{TEMP}$ Voltage Shift

The LM57 is very linear over temperature and supply voltage range. Due to the intrinsic behavior of an NMOS/PMOS rail-to-rail buffer, a slight shift in the output can occur when the supply voltage is ramped over the operating range of the device. The location of the shift is determined by the relative levels of  $V_{DD}$  and  $V_{TEMP}$ . The shift typically occurs when  $V_{DD} - V_{TEMP} = 1$  V.

This slight shift (a few millivolts) takes place over a wide change (approximately 200 mV) in  $V_{DD}$  or  $V_{TEMP}$ . Since the shift takes place over a wide temperature change of 5°C to 20°C,  $V_{TEMP}$  is always monotonic. The accuracy specifications in the table already includes this possible shift.

## 8.4 Device Functional Modes

The LM57 has several modes of operation as detailed in the following drawings.

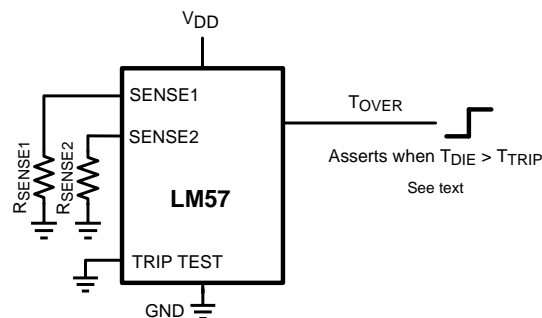
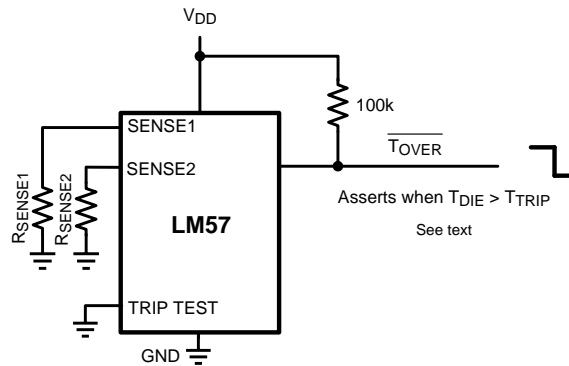
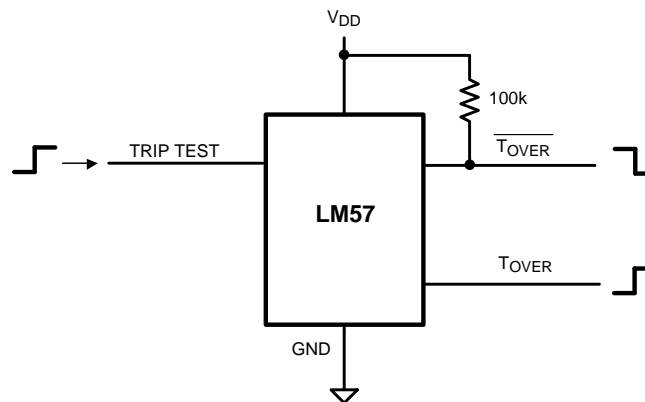

Figure 15. Temperature Switch Using Push-Pull Output

**Device Functional Modes (continued)**

**Figure 16. Temperature Switch Using Open-Drain Output**

As shown in [Figure 17](#) the LM57 has a TRIP Test input simplifying in situ board conductivity testing. Forcing TRIP TEST pin "HIGH" will drive the  $\overline{T_{OVER}}$  pin "LOW" and the  $T_{OVER}$  pin "HIGH".

**Figure 17. Trip Test Digital Output Test Circuit**

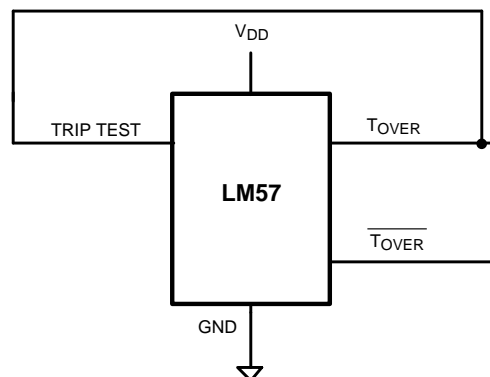
In the circuit shown in [Figure 18](#) when  $T_{OVER}$  goes active high, it drives trip test high. Trip test high causes  $T_{OVER}$  to stay high. It is therefore latched. To release the latch, power down, then power up. The LM57 always comes up in a released condition.

**Figure 18. Simple Latch Circuit**

### Device Functional Modes (continued)

The TRIP TEST pin, normally used to check the operation of the  $T_{\text{OVER}}$  and  $\overline{T_{\text{OVER}}}$  pins, may be used to latch the outputs whenever the temperature exceeds the programmed limit and causes the digital outputs to assert. As shown in Figure 19, when  $T_{\text{OVER}}$  goes high, the TRIP TEST input is also pulled high and causes  $T_{\text{OVER}}$  output to latch high and the  $\overline{T_{\text{OVER}}}$  output to latch low. Momentarily switching the TRIP TEST input low will reset the LM57 to normal operation. The resistor limits the current out of the  $T_{\text{OVER}}$  output pin.

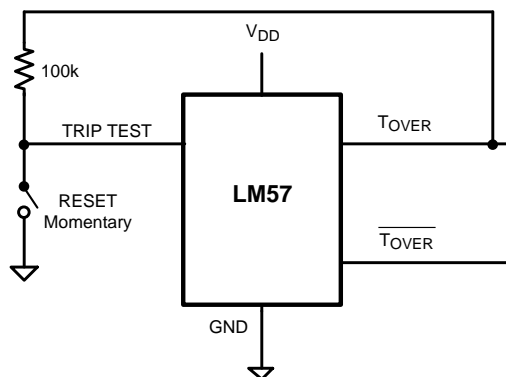

Figure 19. Latch Circuit Using  $T_{\text{OVER}}$  Output

## 9 Application and Implementation

### NOTE

Information in the following applications sections is not part of the TI component specification, and TI does not warrant its accuracy or completeness. TI's customers are responsible for determining suitability of components for their purposes. Customers should validate and test their design implementation to confirm system functionality.

### 9.1 Application Information

The LM57 has several outputs allowing for varying system implementations.

#### 9.1.1 ADC Input Considerations

The LM57 has an analog temperature sensor output ( $V_{TEMP}$ ) that can be directly connected to an ADC (Analog to Digital Converter) input. Most CMOS ADCs found in microcontrollers and ASICs have a sampled data comparator input structure. When the ADC charges the sampling cap, it requires instantaneous charge from the output of the analog source such as the LM57 temperature sensor and many op amps. This requirement is easily accommodated by the addition of a capacitor ( $C_{FILTER}$ ). The size of  $C_{FILTER}$  depends on the size of the sampling capacitor and the sampling frequency. Because not all ADCs have identical input stages, the charge requirements will vary. The general ADC application shown in Figure 20 is an example only.

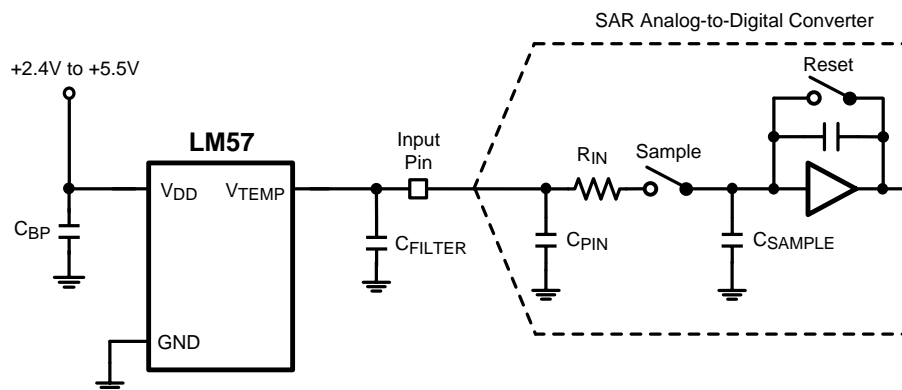

Figure 20. Suggested Connection to a Sampling Analog-to-Digital Converter Input Stage

### 9.2 Typical Application

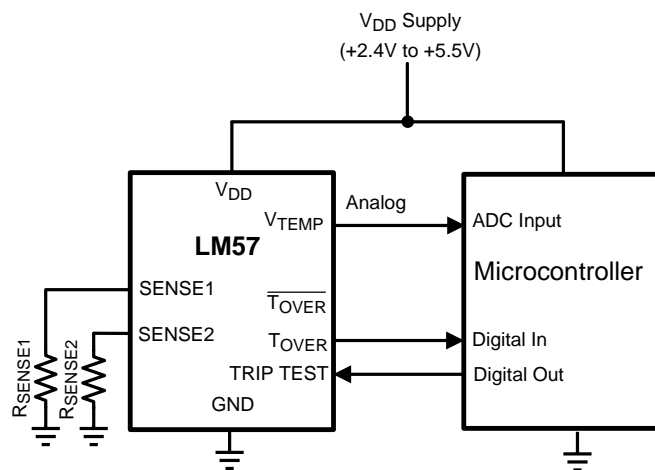

Figure 21. Typical Application Schematic with Microcontroller TRIP TEST Control

## Typical Application (continued)

### 9.2.1 Design Requirements

By simply selecting the value of two resistors the trip point of the LM57 can easily be programmed as described in the following section. If standard 1% values are used the actual trip point threshold is not degraded and stands as described in the Electrical Characteristics section ( ).

### 9.2.2 Detailed Design Procedure

#### 9.2.2.1 Selection of $R_{SENSE}$ Resistors

To set the trip point:

1. Locate the desired trip temperature in [Table 4](#).
2. Identify the corresponding  $R_{SENSE2}$  value by following the column up to the resistor value.
3. Identify the corresponding  $R_{SENSE1}$  value by following the row leftwards to the resistor value.
4. Use only the EIA E96 standard resistor values from the list.
5. Use only a resistor with 1% tolerance and a temperature coefficient of 100 ppm (or better). These restrictions are necessary to stay at the selected setting, and not to slip into an adjacent setting.
6. This is consistent with using resistors from the thick film chip resistors CRCW0402 family. These are available with very small dimensions of L = 1 mm, W = 0.5 mm, H = 0.35 mm.
7. Note that the resistor tolerance does not diminish the accuracy of the trip point. As can be seen in the block diagram these inputs drive the logic inputs of a DAC thus their tolerance does affect the trip point accuracy unless the DAC setting slips into an adjacent level. See patent number 6924758.

### 9.2.3 Application Curves

The typical performance of the LM57 temperature sensor output can be seen in [Figure 22](#). [Figure 23](#) shows the output behavior of the LM57  $T_{OVER}$  output.

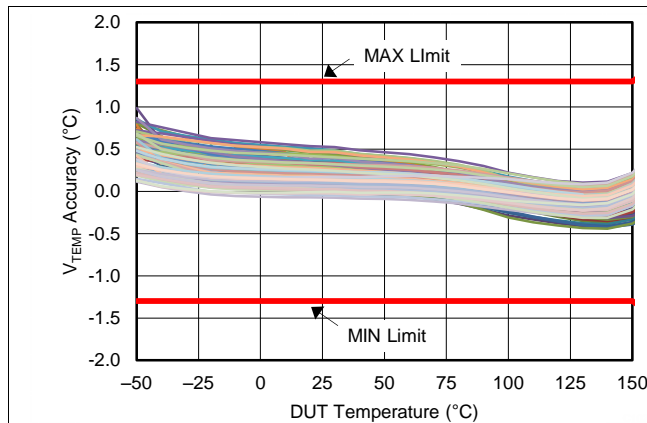

Figure 22. J2  $V_{TEMP}$  Accuracy Characteristics

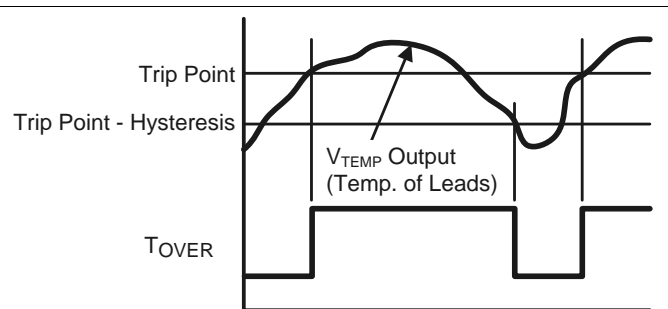
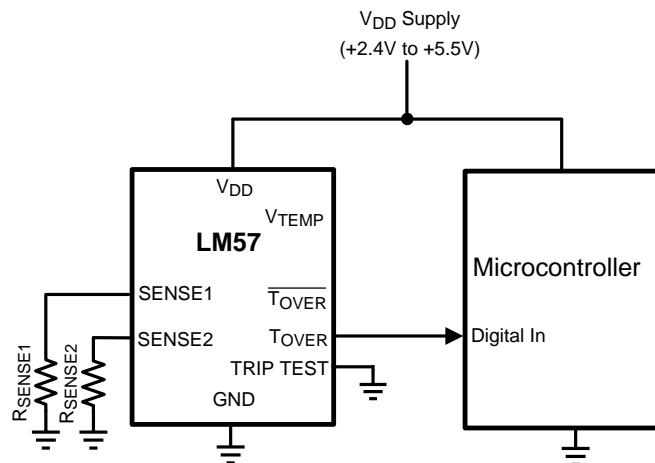

Figure 23. Output Transfer Characteristic

## Typical Application (continued)

### 9.2.4 Grounding of the TRIP TEST Pin

The circuit in [Figure 24](#) shows the TRIP TEST pin grounded. This allows the LM57 to function autonomously without microcontroller intervention. In all other respects this circuit functions similarly to the circuit shown in [Figure 21](#).



**Figure 24. Typical Application Schematic without Microcontroller TRIP TEST Control**

## 10 Power Supply Recommendations

Power supply bypass capacitors are optional and may be required if the supply line is noisy. TI recommends that a local supply decoupling capacitor be used to reduce noise. For noisy environments, TI recommends a 100-nF supply decoupling capacitor placed closed across  $V_{DD}$  and GND pins of LM57.

## 11 Layout

### 11.1 Layout Guidelines

The LM57 can be applied easily in the same way as other integrated-circuit temperature sensors. It can be glued or cemented to a surface. The temperatures of the lands and traces to the other leads of the LM57 will also affect the temperature reading.

Alternatively, the LM57 can be mounted inside a sealed-end metal tube, and can then be dipped into a bath or screwed into a threaded hole in a tank. As with any IC, the LM57 and accompanying wiring and circuits must be kept insulated and dry, to avoid leakage and corrosion. This is especially true if the circuit may operate at cold temperatures where condensation can occur. If moisture creates a short circuit from the  $V_{TEMP}$  output to ground or  $V_{DD}$ , the  $V_{TEMP}$  output from the LM57 will not be correct. Printed-circuit coatings are often used to ensure that moisture cannot corrode the leads or circuit traces.

## 11.2 Layout Example

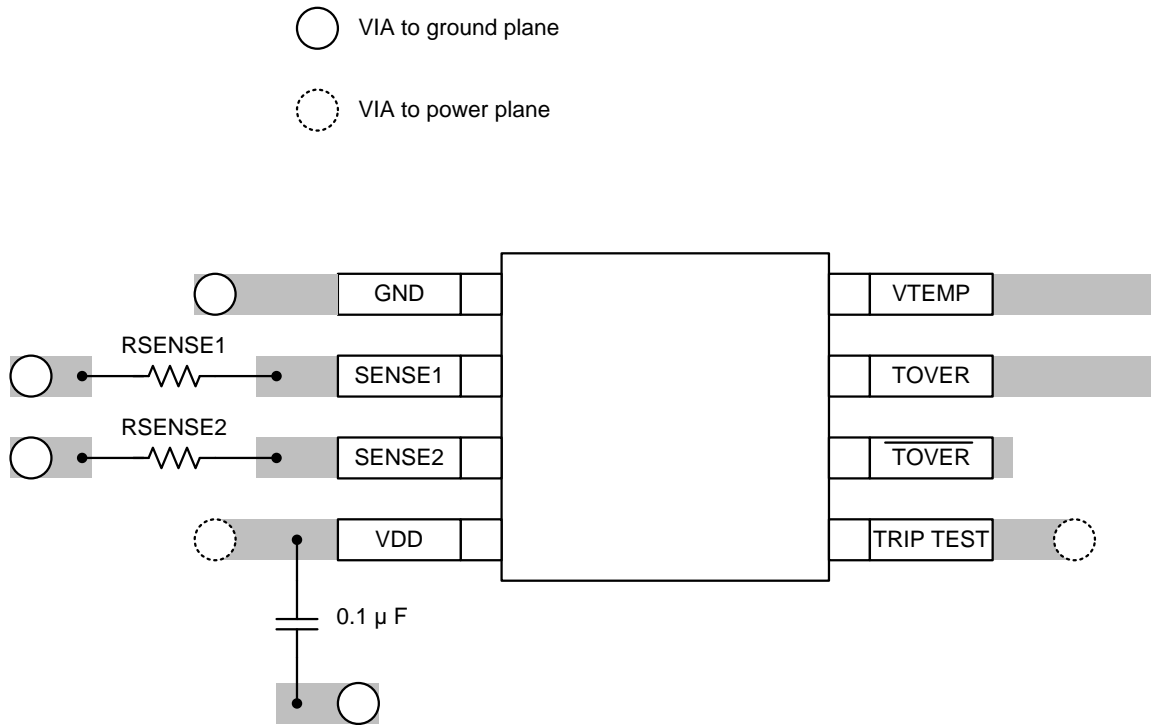
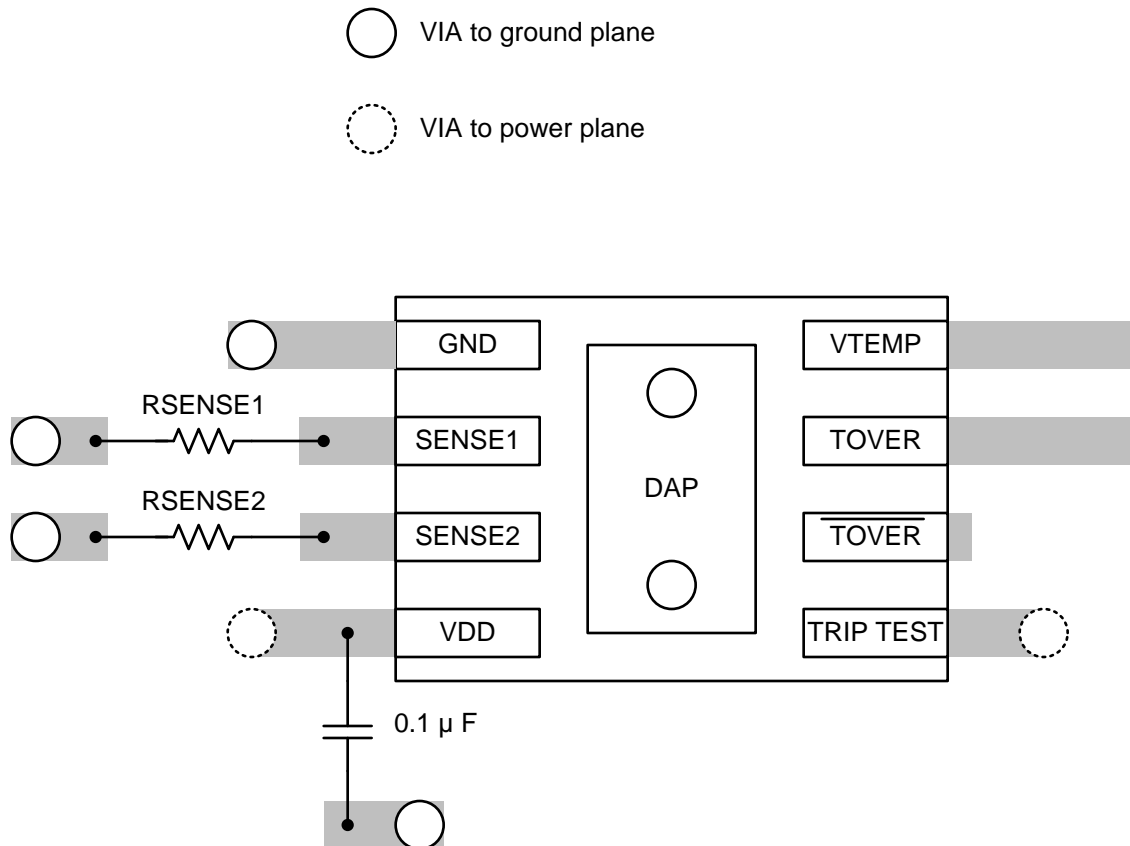

Figure 25. PW (TSSOP) Package Layout Example

**Layout Example (continued)**

The best thermal conductivity to the junction of the LM57 is through the DAP. Make sure it is connected to the surface whose temperature that is being measured.

**Figure 26. SD (WSON) Package Layout Example**

### 11.3 Temperature Considerations

The junction temperature of the LM57 is the actual temperature being measured. The thermal resistance junction-to-ambient ( $R_{\theta JA}$ ) is the parameter (from [Thermal Information](#)) used to calculate the rise of a device junction temperature due to its power dissipation. [Equation 3](#) is used to calculate the rise in the die temperature of the LM57.

$$T_J = T_A + R_{\theta JA} [(V_{DD} I_Q) + (V_{DD} - V_{TEMP}) I_L]$$

where

- $T_A$  is the ambient temperature.
- $I_Q$  is the quiescent current.
- $I_L$  is the load current on  $V_{TEMP}$ .
- $R_{\theta JA}$  can be found in [Thermal Information](#)

(3)

For example using an LM57 in the PW (TSSOP) package, in an application where  $T_A = 30^\circ\text{C}$ ,  $V_{DD} = 5.5 \text{ V}$ ,  $I_{DD} = 28 \mu\text{A}$ , J5 gain,  $V_{TEMP} = 2368 \text{ mV}$ , and  $I_L = 0 \mu\text{A}$ , the total temperature rise would be  $[183^\circ\text{C/W} \times 5.5 \text{ V} \times 28 \mu\text{A}] = 0.028^\circ\text{C}$ . To minimize self-heating, the load current on  $V_{TEMP}$  should be minimized.

## 12 Device and Documentation Support

### 12.1 Documentation Support

#### 12.1.1 Related Documentation

For related documentation, see the following:

- [LM57-Q1 Automotive Grade Data Sheet](#).
- *Reflow Temperature Profile* specifications, [www.ti.com/packaging](http://www.ti.com/packaging).
- *IC Package Thermal Metrics* application report, [SPRA953](#)

### 12.2 Community Resources

The following links connect to TI community resources. Linked contents are provided "AS IS" by the respective contributors. They do not constitute TI specifications and do not necessarily reflect TI's views; see TI's [Terms of Use](#).

**TI E2E™ Online Community** *TI's Engineer-to-Engineer (E2E) Community*. Created to foster collaboration among engineers. At [e2e.ti.com](http://e2e.ti.com), you can ask questions, share knowledge, explore ideas and help solve problems with fellow engineers.

**Design Support** *TI's Design Support* Quickly find helpful E2E forums along with design support tools and contact information for technical support.

### 12.3 Trademarks

E2E is a trademark of Texas Instruments.

All other trademarks are the property of their respective owners.

### 12.4 Electrostatic Discharge Caution



These devices have limited built-in ESD protection. The leads should be shorted together or the device placed in conductive foam during storage or handling to prevent electrostatic damage to the MOS gates.

### 12.5 Glossary

[SLYZ022](#) — *TI Glossary*.

This glossary lists and explains terms, acronyms, and definitions.

## 13 Mechanical, Packaging, and Orderable Information

The following pages include mechanical, packaging, and orderable information. This information is the most current data available for the designated devices. This data is subject to change without notice and revision of this document. For browser-based versions of this data sheet, refer to the left-hand navigation.

**PACKAGING INFORMATION**

Orderable Device	Status (1)	Package Type	Package Drawing	Pins	Package Qty	Eco Plan (2)	Lead/Ball Finish (6)	MSL Peak Temp (3)	Op Temp (°C)	Device Marking (4/5)	Samples
LM57BISD-10/NOPB	ACTIVE	WSO	NGR	8	1000	Green (RoHS & no Sb/Br)	CU SN	Level-3-260C-168 HR	-50 to 150	57B9	<a href="#">Samples</a>
LM57BISD-5/NOPB	ACTIVE	WSO	NGR	8	1000	Green (RoHS & no Sb/Br)	CU SN	Level-3-260C-168 HR	-50 to 150	57B5	<a href="#">Samples</a>
LM57BISDX-10/NOPB	ACTIVE	WSO	NGR	8	4500	Green (RoHS & no Sb/Br)	CU SN	Level-3-260C-168 HR	-50 to 150	57B9	<a href="#">Samples</a>
LM57BISDX-5/NOPB	ACTIVE	WSO	NGR	8	4500	Green (RoHS & no Sb/Br)	CU SN	Level-3-260C-168 HR	-50 to 150	57B5	<a href="#">Samples</a>
LM57CISD-10/NOPB	ACTIVE	WSO	NGR	8	1000	Green (RoHS & no Sb/Br)	CU SN	Level-3-260C-168 HR	-50 to 150	57C9	<a href="#">Samples</a>
LM57CISD-5/NOPB	ACTIVE	WSO	NGR	8	1000	Green (RoHS & no Sb/Br)	CU SN	Level-3-260C-168 HR	-50 to 150	57C5	<a href="#">Samples</a>
LM57CISDX-10/NOPB	ACTIVE	WSO	NGR	8	4500	Green (RoHS & no Sb/Br)	CU SN	Level-3-260C-168 HR	-50 to 150	57C9	<a href="#">Samples</a>
LM57CISDX-5/NOPB	ACTIVE	WSO	NGR	8	4500	Green (RoHS & no Sb/Br)	CU SN	Level-3-260C-168 HR	-50 to 150	57C5	<a href="#">Samples</a>
LM57FPW	ACTIVE	TSSOP	PW	8	150	Green (RoHS & no Sb/Br)	CU NIPDAU	Level-2-260C-1 YEAR	-50 to 150	LM57F	<a href="#">Samples</a>
LM57FPWR	ACTIVE	TSSOP	PW	8	2000	Green (RoHS & no Sb/Br)	CU NIPDAU	Level-2-260C-1 YEAR	-50 to 150	LM57F	<a href="#">Samples</a>
LM57TPW	ACTIVE	TSSOP	PW	8	150	Green (RoHS & no Sb/Br)	CU NIPDAU	Level-2-260C-1 YEAR	-50 to 150	LM57T	<a href="#">Samples</a>
LM57TPWR	ACTIVE	TSSOP	PW	8	2000	Green (RoHS & no Sb/Br)	CU NIPDAU	Level-2-260C-1 YEAR	-50 to 150	LM57T	<a href="#">Samples</a>

(1) The marketing status values are defined as follows:

**ACTIVE:** Product device recommended for new designs.

**LIFEBUY:** TI has announced that the device will be discontinued, and a lifetime-buy period is in effect.

**NRND:** Not recommended for new designs. Device is in production to support existing customers, but TI does not recommend using this part in a new design.

**PREVIEW:** Device has been announced but is not in production. Samples may or may not be available.

**OBSELETE:** TI has discontinued the production of the device.

(2) Eco Plan - The planned eco-friendly classification: Pb-Free (RoHS), Pb-Free (RoHS Exempt), or Green (RoHS & no Sb/Br) - please check <http://www.ti.com/productcontent> for the latest availability information and additional product content details.

**TBD:** The Pb-Free/Green conversion plan has not been defined.

---

**Pb-Free (RoHS):** TI's terms "Lead-Free" or "Pb-Free" mean semiconductor products that are compatible with the current RoHS requirements for all 6 substances, including the requirement that lead not exceed 0.1% by weight in homogeneous materials. Where designed to be soldered at high temperatures, TI Pb-Free products are suitable for use in specified lead-free processes.

**Pb-Free (RoHS Exempt):** This component has a RoHS exemption for either 1) lead-based flip-chip solder bumps used between the die and package, or 2) lead-based die adhesive used between the die and leadframe. The component is otherwise considered Pb-Free (RoHS compatible) as defined above.

**Green (RoHS & no Sb/Br):** TI defines "Green" to mean Pb-Free (RoHS compatible), and free of Bromine (Br) and Antimony (Sb) based flame retardants (Br or Sb do not exceed 0.1% by weight in homogeneous material)

<sup>(3)</sup> MSL, Peak Temp. - The Moisture Sensitivity Level rating according to the JEDEC industry standard classifications, and peak solder temperature.

<sup>(4)</sup> There may be additional marking, which relates to the logo, the lot trace code information, or the environmental category on the device.

<sup>(5)</sup> Multiple Device Markings will be inside parentheses. Only one Device Marking contained in parentheses and separated by a "~" will appear on a device. If a line is indented then it is a continuation of the previous line and the two combined represent the entire Device Marking for that device.

<sup>(6)</sup> Lead/Ball Finish - Orderable Devices may have multiple material finish options. Finish options are separated by a vertical ruled line. Lead/Ball Finish values may wrap to two lines if the finish value exceeds the maximum column width.

**Important Information and Disclaimer:** The information provided on this page represents TI's knowledge and belief as of the date that it is provided. TI bases its knowledge and belief on information provided by third parties, and makes no representation or warranty as to the accuracy of such information. Efforts are underway to better integrate information from third parties. TI has taken and continues to take reasonable steps to provide representative and accurate information but may not have conducted destructive testing or chemical analysis on incoming materials and chemicals. TI and TI suppliers consider certain information to be proprietary, and thus CAS numbers and other limited information may not be available for release.

In no event shall TI's liability arising out of such information exceed the total purchase price of the TI part(s) at issue in this document sold by TI to Customer on an annual basis.

#### **OTHER QUALIFIED VERSIONS OF LM57 :**

- Automotive: [LM57-Q1](#)

NOTE: Qualified Version Definitions:

- Automotive - Q100 devices qualified for high-reliability automotive applications targeting zero defects

**TAPE AND REEL INFORMATION**

**QUADRANT ASSIGNMENTS FOR PIN 1 ORIENTATION IN TAPE**

\*All dimensions are nominal

Device	Package Type	Package Drawing	Pins	SPQ	Reel Diameter (mm)	Reel Width W1 (mm)	A0 (mm)	B0 (mm)	K0 (mm)	P1 (mm)	W (mm)	Pin1 Quadrant
LM57BISD-10/NOPB	WSON	NGR	8	1000	178.0	12.4	2.8	2.8	1.0	8.0	12.0	Q1
LM57BISD-5/NOPB	WSON	NGR	8	1000	178.0	12.4	2.8	2.8	1.0	8.0	12.0	Q1
LM57BISDX-10/NOPB	WSON	NGR	8	4500	330.0	12.4	2.8	2.8	1.0	8.0	12.0	Q1
LM57BISDX-5/NOPB	WSON	NGR	8	4500	330.0	12.4	2.8	2.8	1.0	8.0	12.0	Q1
LM57CISD-10/NOPB	WSON	NGR	8	1000	178.0	12.4	2.8	2.8	1.0	8.0	12.0	Q1
LM57CISD-5/NOPB	WSON	NGR	8	1000	178.0	12.4	2.8	2.8	1.0	8.0	12.0	Q1
LM57CISDX-10/NOPB	WSON	NGR	8	4500	330.0	12.4	2.8	2.8	1.0	8.0	12.0	Q1
LM57CISDX-5/NOPB	WSON	NGR	8	4500	330.0	12.4	2.8	2.8	1.0	8.0	12.0	Q1
LM57FPWR	TSSOP	PW	8	2000	330.0	12.4	7.0	3.6	1.6	8.0	12.0	Q1
LM57TPWR	TSSOP	PW	8	2000	330.0	12.4	7.0	3.6	1.6	8.0	12.0	Q1

**TAPE AND REEL BOX DIMENSIONS**

\*All dimensions are nominal

Device	Package Type	Package Drawing	Pins	SPQ	Length (mm)	Width (mm)	Height (mm)
LM57BISD-10/NOPB	WSON	NGR	8	1000	210.0	185.0	35.0
LM57BISD-5/NOPB	WSON	NGR	8	1000	210.0	185.0	35.0
LM57BISDX-10/NOPB	WSON	NGR	8	4500	367.0	367.0	35.0
LM57BISDX-5/NOPB	WSON	NGR	8	4500	367.0	367.0	35.0
LM57CISD-10/NOPB	WSON	NGR	8	1000	210.0	185.0	35.0
LM57CISD-5/NOPB	WSON	NGR	8	1000	210.0	185.0	35.0
LM57CISDX-10/NOPB	WSON	NGR	8	4500	367.0	367.0	35.0
LM57CISDX-5/NOPB	WSON	NGR	8	4500	367.0	367.0	35.0
LM57FPWR	TSSOP	PW	8	2000	367.0	367.0	35.0
LM57TPWR	TSSOP	PW	8	2000	367.0	367.0	35.0



PW0008A



**PACKAGE OUTLINE**  
**TSSOP - 1.2 mm max height**

SMALL OUTLINE PACKAGE



NOTES:

1. All linear dimensions are in millimeters. Any dimensions in parenthesis are for reference only. Dimensioning and tolerancing per ASME Y14.5M.
2. This drawing is subject to change without notice.
3. This dimension does not include mold flash, protrusions, or gate burrs. Mold flash, protrusions, or gate burrs shall not exceed 0.15 mm per side.
4. This dimension does not include interlead flash. Interlead flash shall not exceed 0.25 mm per side.
5. Reference JEDEC registration MO-153, variation AA.

# EXAMPLE BOARD LAYOUT

PW0008A

TSSOP - 1.2 mm max height

SMALL OUTLINE PACKAGE

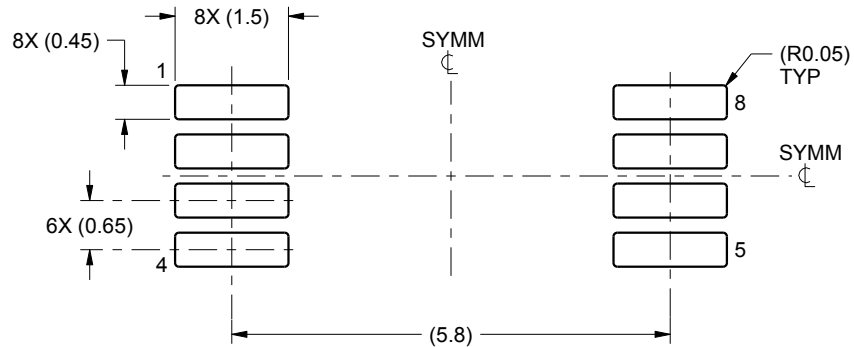

LAND PATTERN EXAMPLE  
SCALE:10X



SOLDER MASK DETAILS  
NOT TO SCALE

4221848/A 02/2015

NOTES: (continued)

- 6. Publication IPC-7351 may have alternate designs.
- 7. Solder mask tolerances between and around signal pads can vary based on board fabrication site.

# EXAMPLE STENCIL DESIGN

PW0008A

TSSOP - 1.2 mm max height

SMALL OUTLINE PACKAGE



SOLDER PASTE EXAMPLE  
BASED ON 0.125 mm THICK STENCIL  
SCALE:10X

4221848/A 02/2015

NOTES: (continued)

8. Laser cutting apertures with trapezoidal walls and rounded corners may offer better paste release. IPC-7525 may have alternate design recommendations.
9. Board assembly site may have different recommendations for stencil design.

## IMPORTANT NOTICE

Texas Instruments Incorporated and its subsidiaries (TI) reserve the right to make corrections, enhancements, improvements and other changes to its semiconductor products and services per JESD46, latest issue, and to discontinue any product or service per JESD48, latest issue. Buyers should obtain the latest relevant information before placing orders and should verify that such information is current and complete. All semiconductor products (also referred to herein as "components") are sold subject to TI's terms and conditions of sale supplied at the time of order acknowledgment.

TI warrants performance of its components to the specifications applicable at the time of sale, in accordance with the warranty in TI's terms and conditions of sale of semiconductor products. Testing and other quality control techniques are used to the extent TI deems necessary to support this warranty. Except where mandated by applicable law, testing of all parameters of each component is not necessarily performed.

TI assumes no liability for applications assistance or the design of Buyers' products. Buyers are responsible for their products and applications using TI components. To minimize the risks associated with Buyers' products and applications, Buyers should provide adequate design and operating safeguards.

TI does not warrant or represent that any license, either express or implied, is granted under any patent right, copyright, mask work right, or other intellectual property right relating to any combination, machine, or process in which TI components or services are used. Information published by TI regarding third-party products or services does not constitute a license to use such products or services or a warranty or endorsement thereof. Use of such information may require a license from a third party under the patents or other intellectual property of the third party, or a license from TI under the patents or other intellectual property of TI.

Reproduction of significant portions of TI information in TI data books or data sheets is permissible only if reproduction is without alteration and is accompanied by all associated warranties, conditions, limitations, and notices. TI is not responsible or liable for such altered documentation. Information of third parties may be subject to additional restrictions.

Resale of TI components or services with statements different from or beyond the parameters stated by TI for that component or service voids all express and any implied warranties for the associated TI component or service and is an unfair and deceptive business practice. TI is not responsible or liable for any such statements.

Buyer acknowledges and agrees that it is solely responsible for compliance with all legal, regulatory and safety-related requirements concerning its products, and any use of TI components in its applications, notwithstanding any applications-related information or support that may be provided by TI. Buyer represents and agrees that it has all the necessary expertise to create and implement safeguards which anticipate dangerous consequences of failures, monitor failures and their consequences, lessen the likelihood of failures that might cause harm and take appropriate remedial actions. Buyer will fully indemnify TI and its representatives against any damages arising out of the use of any TI components in safety-critical applications.

In some cases, TI components may be promoted specifically to facilitate safety-related applications. With such components, TI's goal is to help enable customers to design and create their own end-product solutions that meet applicable functional safety standards and requirements. Nonetheless, such components are subject to these terms.

No TI components are authorized for use in FDA Class III (or similar life-critical medical equipment) unless authorized officers of the parties have executed a special agreement specifically governing such use.

Only those TI components which TI has specifically designated as military grade or "enhanced plastic" are designed and intended for use in military/aerospace applications or environments. Buyer acknowledges and agrees that any military or aerospace use of TI components which have **not** been so designated is solely at the Buyer's risk, and that Buyer is solely responsible for compliance with all legal and regulatory requirements in connection with such use.

TI has specifically designated certain components as meeting ISO/TS16949 requirements, mainly for automotive use. In any case of use of non-designated products, TI will not be responsible for any failure to meet ISO/TS16949.

### Products

Audio	<a href="http://www.ti.com/audio">www.ti.com/audio</a>
Amplifiers	<a href="http://amplifier.ti.com">amplifier.ti.com</a>
Data Converters	<a href="http://dataconverter.ti.com">dataconverter.ti.com</a>
DLP® Products	<a href="http://www.dlp.com">www.dlp.com</a>
DSP	<a href="http://dsp.ti.com">dsp.ti.com</a>
Clocks and Timers	<a href="http://www.ti.com/clocks">www.ti.com/clocks</a>
Interface	<a href="http://interface.ti.com">interface.ti.com</a>
Logic	<a href="http://logic.ti.com">logic.ti.com</a>
Power Mgmt	<a href="http://power.ti.com">power.ti.com</a>
Microcontrollers	<a href="http://microcontroller.ti.com">microcontroller.ti.com</a>
RFID	<a href="http://www.ti-rfid.com">www.ti-rfid.com</a>
OMAP Applications Processors	<a href="http://www.ti.com/omap">www.ti.com/omap</a>
Wireless Connectivity	<a href="http://www.ti.com/wirelessconnectivity">www.ti.com/wirelessconnectivity</a>

### Applications



Automotive and Transportation	<a href="http://www.ti.com/automotive">www.ti.com/automotive</a>
Communications and Telecom	<a href="http://www.ti.com/communications">www.ti.com/communications</a>
Computers and Peripherals	<a href="http://www.ti.com/computers">www.ti.com/computers</a>
Consumer Electronics	<a href="http://www.ti.com/consumer-apps">www.ti.com/consumer-apps</a>
Energy and Lighting	<a href="http://www.ti.com/energy">www.ti.com/energy</a>
Industrial	<a href="http://www.ti.com/industrial">www.ti.com/industrial</a>
Medical	<a href="http://www.ti.com/medical">www.ti.com/medical</a>
Security	<a href="http://www.ti.com/security">www.ti.com/security</a>
Space, Avionics and Defense	<a href="http://www.ti.com/space-avionics-defense">www.ti.com/space-avionics-defense</a>
Video and Imaging	<a href="http://www.ti.com/video">www.ti.com/video</a>

### TI E2E Community

[e2e.ti.com](http://e2e.ti.com)

## Looking for pricing, stock, or lifecycle information?

Click below to explore more details on WIN SOURCE:

-  [View LM57BISD-10/NOPB on WIN SOURCE](#)
-  [Texas Instruments](#) Information

## Optimize Your Supply Chain with WIN SOURCE Solutions

-  Global Sourcing Solution
-  Obsolete Management
-  Cost Control Management
-  Shortage Management
-  Alternative Solution
-  Excess Inventory Management