

TSB12LV01B-EP

**IEEE 1394-1995 High-Speed Serial-Bus
Link-Layer Controller**

Data Manual

Contents

<i>Section</i>	<i>Title</i>	<i>Page</i>
1	Overview	1-1
1.1	Description	1-1
1.1.1	Link Core	1-2
1.1.2	Physical-Link Interface	1-2
1.1.3	Host Bus Interface	1-2
1.1.4	General	1-2
1.1.5	Enhanced Plastic	1-2
1.1.6	Ordering Information	1-2
1.2	Terminal Assignments	1-3
1.3	Terminal Functions	1-4
2	Architecture	2-1
2.1	Functional Block Diagram	2-1
2.1.1	Physical Interface	2-1
2.1.2	Transmitter	2-1
2.1.3	Receiver	2-2
2.1.4	Transmit and Receive FIFO Memories	2-2
2.1.5	Cycle Timer	2-2
2.1.6	Cycle Monitor	2-3
2.1.7	Cyclic Redundancy Check (CRC)	2-3
2.1.8	Internal Registers	2-3
2.1.9	Host Bus Interface	2-3
3	Internal Registers	3-1
3.1	General	3-1
3.2	Internal Register Definitions	3-1
3.2.1	Version/Revision Register (@00h)	3-3
3.2.2	Node-Address/Transmitter Acknowledge Register (@04h)	3-3
3.2.3	Control Register (@08h)	3-4
3.2.4	Interrupt and Interrupt-Mask Registers (@0Ch, @10h)	3-5
3.2.5	Cycle-Timer Register (@14h)	3-8
3.2.6	Isochronous Receive-Port Number Register (@18h)	3-8
3.2.7	FIFO Control Register (@1Ch)	3-8
3.2.8	Diagnostic Control Register (@20h)	3-9
3.2.9	PHY-Chip Access Register (@24h)	3-9
3.2.10	Asynchronous Transmit-FIFO (ATF) Status Register (@30h)	3-10
3.2.11	ITF Status Register (@34h)	3-11
3.2.12	GRF Status Register (@3Ch)	3-11
3.2.13	Host Control Register (@40h)	3-12
3.2.14	Mux Control Register (@44h)	3-13
3.3	FIFO Access	3-16

3.3.1	General	3-16
3.3.2	ATF Access	3-17
3.3.3	ITF Access	3-18
3.3.4	General-Receive FIFO (GRF)	3-20
3.3.5	RAM Test Mode	3-21
4	TSB12LV01B Data Formats	4-1
4.1	Asynchronous Transmit (Host Bus to TSB12LV01B)	4-1
4.1.1	Quadlet Transmit	4-1
4.1.2	Block Transmit	4-3
4.2	Asynchronous Receive (TSB12LV01B to Host Bus)	4-6
4.2.1	Quadlet Receive	4-6
4.2.2	Block Receive	4-9
4.3	Isochronous Transmit (Host Bus to TSB12LV01B)	4-12
4.4	Isochronous Receive (TSB12LV01B to Host Bus)	4-12
4.5	Snoop Receive	4-13
4.6	CycleMark	4-14
4.7	PHY Configuration Transmit	4-14
4.8	Link-On Transmit	4-15
4.9	Receive Self-ID	4-16
4.10	Received PHY Configuration and Link-On Packet	4-18
5	Electrical Characteristics	5-1
5.1	Absolute Maximum Ratings Over Operating Free-Air Temperature Range	5-1
5.2	Recommended Operating Conditions	5-2
5.3	Electrical Characteristics Over Recommended Ranges of Supply Voltage and Operating Free-Air Temperature	5-2
5.4	Host-Interface Timing Requirements, $T_A = 25^\circ\text{C}$	5-3
5.5	Host-Interface Switching Characteristics Over Recommended Operating Free-Air Temperature Range, $C_L = 45\text{ pF}$	5-3
5.6	Cable PHY-Layer-Interface Timing Requirements Over Recommended Operating Free-Air Temperature Range	5-3
5.7	Cable PHY-Layer-Interface Switching Characteristics Over Recommended Operating Free-Air Temperature Range, $C_L = 45\text{ pF}$	5-4
5.8	Miscellaneous Timing Requirements Over Recommended Operating Free-Air Temperature Range	5-4
5.9	Miscellaneous Signal Switching Characteristics Over Recommended Operating Free-Air Temperature Range	5-4
6	Parameter Measurement Information	6-1
7	TSB12LV01B to 1394 PHY Interface Specification	7-1
7.1	Principles of Operation	7-1
7.2	TSB12LV01B Service Request	7-2
7.3	Status Transfer	7-5
7.4	Receive Operation	7-6
7.5	Transmit Operation	7-8
8	Mechanical Data	8-1

List of Illustrations

<i>Figure</i>	<i>Title</i>	<i>Page</i>
1-1	TSB12LV01B Terminal Functions	1-4
2-1	TSB12LV01B Block Diagram	2-1
3-1	Internal Register Map	3-2
3-2	Interrupt Logic Diagram Example	3-6
3-3	TSB12LV01B Controller-FIFO-Access Address Map	3-16
4-1	Quadlet-Transmit Format (Write Request)	4-1
4-2	Quadlet-Transmit Format (Read Request)	4-1
4-3	Quadlet-Transmit Format (Read Response)	4-2
4-4	Quadlet-Transmit Format (Write Response)	4-2
4-5	Block-Transmit Format (Write Request)	4-4
4-6	Block-Transmit Format (Read Request)	4-4
4-7	Block-Transmit Format (Read Response)	4-4
4-8	Block-Transmit Format (Write Response)	4-5
4-9	Quadlet-Receive Format (Write Request)	4-6
4-10	Quadlet-Receive Format (Read Request)	4-6
4-11	Quadlet-Receive Format (Read Response)	4-7
4-12	Quadlet-Receive Format (Write Response)	4-7
4-13	Block-Receive Format (Write Request)	4-9
4-14	Block-Receive Format (Read Request)	4-9
4-15	Block-Receive Format (Read Response)	4-10
4-16	Block-Receive Format (Write Response)	4-10
4-17	Isochronous-Transmit Format	4-12
4-18	Isochronous-Receive Format	4-12
4-19	Snoop Format	4-13
4-20	CycleMark Format	4-14
4-21	PHY-Configuration Packet Format	4-14
4-22	Link-On Packet Format	4-15
4-23	Receive Self-ID Packet Format(RxSID bit = 1)	4-16
4-24	PHY Self-ID Packet #0 Format	4-16
4-25	PHY Self-ID Packet #1 Format	4-16
4-26	PHY Self-ID Packet #2 Format	4-17
6-1	BCLK Waveform	6-1
6-2	Host-Interface Write-Cycle Waveforms (Address: 00h – 2Ch)	6-1
6-3	Host-Interface Read-Cycle Waveforms (Address: 00h – 2Ch)	6-2
6-4	Host-Interface Quick Write-Cycle Waveforms (Address 30h)	6-2
6-5	Host-Interface Quick Read-Cycle Waveforms (ADDRESS 30h)	6-3
6-6	Burst Write Waveforms	6-3
6-7	Burst Read Waveforms	6-4
6-8	SCLK Waveform	6-4
6-9	TSB12LV01B-to-PHY-Layer Interface Transfer Waveforms	6-4
6-10	PHY Layer Interface-to-TSB12LV01B Transfer Waveforms	6-5

6-11 TSB12LV01B Link-Request-to-PHY-Layer Interface Waveforms	6-5
6-12 Interrupt Waveform	6-5
6-13 CycleIn Waveform	6-6
6-14 CYCLEIN and CYCLEOUT Waveforms	6-6
7-1 PHY-LLC Interface	7-1
7-2 LREQ Request Stream	7-2
7-3 Status Transfer Timing	7-6
7-4 Normal Packet Reception Timing	7-7
7-5 Null Packet Reception Timing	7-7
7-6 Normal Packet Transmission Timing	7-9

List of Tables

<i>Table</i>	<i>Title</i>	<i>Page</i>
1-1	Terminal Functions	1-4
3-1	Version/Revision Register Field Descriptions	3-3
3-2	Node-Address/Transmitter Acknowledge Register Field Descriptions	3-3
3-3	Control-Register Field Descriptions	3-4
3-4	Interrupt- and Mask-Register Field Descriptions	3-6
3-5	Cycle-Timer Register Field Descriptions	3-8
3-6	Isochronous Receive-Port Number Register Field Descriptions	3-8
3-7	Node-Address/Transmitter Acknowledge Register Field Descriptions	3-8
3-8	Diagnostic Control and Status-Register Field Descriptions	3-9
3-9	PHY-Chip Access Register	3-10
3-10	ATF Status Register	3-10
3-11	ITF Status Register	3-11
3-12	GRF Status Register	3-11
3-13	Host Control Register Description	3-12
3-14	Mux Control Register Description (GPO0 Field)	3-13
3-15	Mux Control Register Description (GPO1 Field)	3-14
3-16	Mux Control Register Description (GPO2 Field)	3-15
3-17	Control Bit Value	3-22
4-1	Quadlet-Transmit Format	4-3
4-2	Block-Transmit Format Functions	4-5
4-3	Quadlet-Receive Format Functions	4-8
4-4	Block-Receive Format Functions	4-11
4-5	Isochronous-Transmit Functions	4-12
4-6	Isochronous-Receive Functions	4-13
4-7	Snoop Functions	4-13
4-8	CycleMark Function	4-14
4-9	PHY-Configuration Functions	4-15
4-10	Link-On Packet Functions	4-15
4-11	Received Self-ID Packet Functions	4-16
4-12	PHY Self-ID Packet Fields	4-17
7-1	CTL Encoding When the PHY Has Control of the Bus	7-2
7-2	CTL Encoding When the TSB12LV01B Has Control of the Bus	7-2
7-3	Request Stream Bit Length	7-2
7-4	Request Type Encoding	7-3
7-5	Bus Request	7-3
7-6	Bus Request Speed Encoding	7-3
7-7	Read Register Request	7-4
7-8	Write Register Request	7-4
7-9	Acceleration Control Request	7-4
7-10	Status Bits	7-6
7-11	Receive Speed Codes	7-8

1 Overview

1.1 Description

The TSB12LV01B is an IEEE 1394-1995 standard (from now on referred to only as 1394) high-speed serial-bus link-layer controller that allows for easy integration into an I/O subsystem. The TSB12LV01B provides a high-performance IEEE 1394-1995 interface with the capability of transferring data between the 32-bit host bus, the 1394 PHY-link interface, and external devices connected to the local bus interface. The 1394 PHY-link interface provides the connection to the 1394 physical (PHY) layer device and is supported by the link-layer controller (LLC). The LLC provides the control for transmitting and receiving 1394 packet data between the FIFO and PHY-link interface at rates of 100 Mb/s, 200 Mb/s, and 400 Mb/s. The TSB12LV01B transmits and receives correctly-formatted 1394 packets and generates and inspects the 32-bit cyclic redundancy check (CRC). The TSB12LV01B is capable of being cycle master and supports reception of isochronous data on two channels. TSB12LV01B has a generic 32-bit host bus interface, which will connect to most 32-bit hosts. The LLC also provides the capability to receive status from the physical layer device and to access the physical layer control and status registers by the application software. An internal 2K-byte memory is provided that can be configured as multiple variable-size FIFOs and eliminates the need for external FIFOs. Separate FIFOs can be user configured to support general 1394 receive, asynchronous transmit, and isochronous transmit transfer operations. These functions are accomplished by appropriately sizing the general receive FIFO (GRF), asynchronous transmit FIFO (ATF), and isochronous transmit FIFO (ITF).

The TSB12LV01B is a revision of the TSB12LV01A, with feature enhancements and corrections. It is pin for pin compatible with the TSB12LV01A with the restrictions noted below. It is also software compatible with the extensions noted below.

All errata items to the TSB12LV01A have been fixed, and the following feature enhancements have been made:

- Two new internal registers have been added at CFR address 40h and 44h. The *Host Bus Control Register* at 40h and the *Mux Control Register* @44h are described in section 3.2.
- Three programmable general-purpose output pins have been added. A detailed description is provided in section 1.3.
- Several pin changes have been made. Refer to *TSB12LV01A to TSB12LV01B Transition Document*, TI literature number SLLA081 dated May 2000.

However, there are three restrictions that were not present in the TSB12LV01A device:

- The TSB12LV01B may only operate with a 50 MHz host-interface clock (BCLK) if the duty cycle is less than 5% away from the 50-50 point, (i.e., the duty cycle must be within 45-55% inclusive). A 40-60% duty cycle clock is acceptable for host clock frequencies at or below 47 MHz.
- The TSB12LV01B does not have bus holder cells on the PHY-link interface.
- As a result of removing the bus holder cells, the $\overline{\text{ISO}}$ pin (pin 69) was replaced with a Vcc pin on the TSB12LV01B.

This document is not intended to serve as a tutorial on 1394; users are referred to the IEEE 1394-1995 serial bus standard for detailed information regarding the 1394 high-speed serial bus.

The following are features of the TSB12LV01B.

1.1.1 Link Core

- Supports Provision of IEEE 1394-1995 (1394) Standard for High-Performance Serial Bus
- Transmits and Receives Correctly Formatted 1394 Packets
- Supports Asynchronous and Isochronous Data Transfers
- Performs Function of 1394 Cycle Master
- Generates and Checks 32-Bit CRC
- Detects Lost Cycle-Start Messages
- Contains Asynchronous, Isochronous, and General-Receive FIFOs Totaling 2K Bytes

1.1.2 Physical-Link Interface

- Compatible With Texas Instruments Physical Layer Devices (PHYs)
- Supports Transfer Speeds of 100, 200, and 400 Mbits/s
- Timing Compliant with IEEE 1394a–2000

1.1.3 Host Bus Interface

- Provides Chip Control With Directly Addressable Registers
- Is Interrupt Driven to Minimize Host Polling
- Has a Generic 32-Bit Host Bus Interface

1.1.4 General

- Operates From a 3.3-V Power Supply While Maintaining 5-V Tolerant Inputs
- Manufactured With Low-Power CMOS Technology
- 100-Pin PZT Package for -40°C to 85°C (I Temperature) Operation

1.1.5 Enhanced Plastic

- Controlled Baseline
 - One Assembly/Test Site, One Fabrication Site
- Extended Temperature Performance of -40°C to 85°C
- Enhanced Diminishing Manufacturing Sources (DMS) Support
- Enhanced Product Change Notification
- Qualification Pedigree†

† Component qualification in accordance with JEDEC and industry standards to ensure reliable operation over an extended temperature range. This includes, but is not limited to, Highly Accelerated Stress Test (HAST) or biased 85/85, temperature cycle, autoclave or unbiased HAST, electromigration, bond intermetallic life, and mold compound life. Such qualification testing should not be viewed as justifying use of this component beyond specified performance and environmental limits.

1.1.6 Ordering Information

T _A	PACKAGE‡	ORDERABLE PART NUMBER	TOP-SIDE MARKING
-40°C to 85°C	PQFP – PZT	TSB12LV01BIPZTEP	12LV01BIEP

‡ Package drawings, standard packing quantities, thermal data, symbolization, and PCB design guidelines are available at www.ti.com/sc/package.

1.2 Terminal Assignments

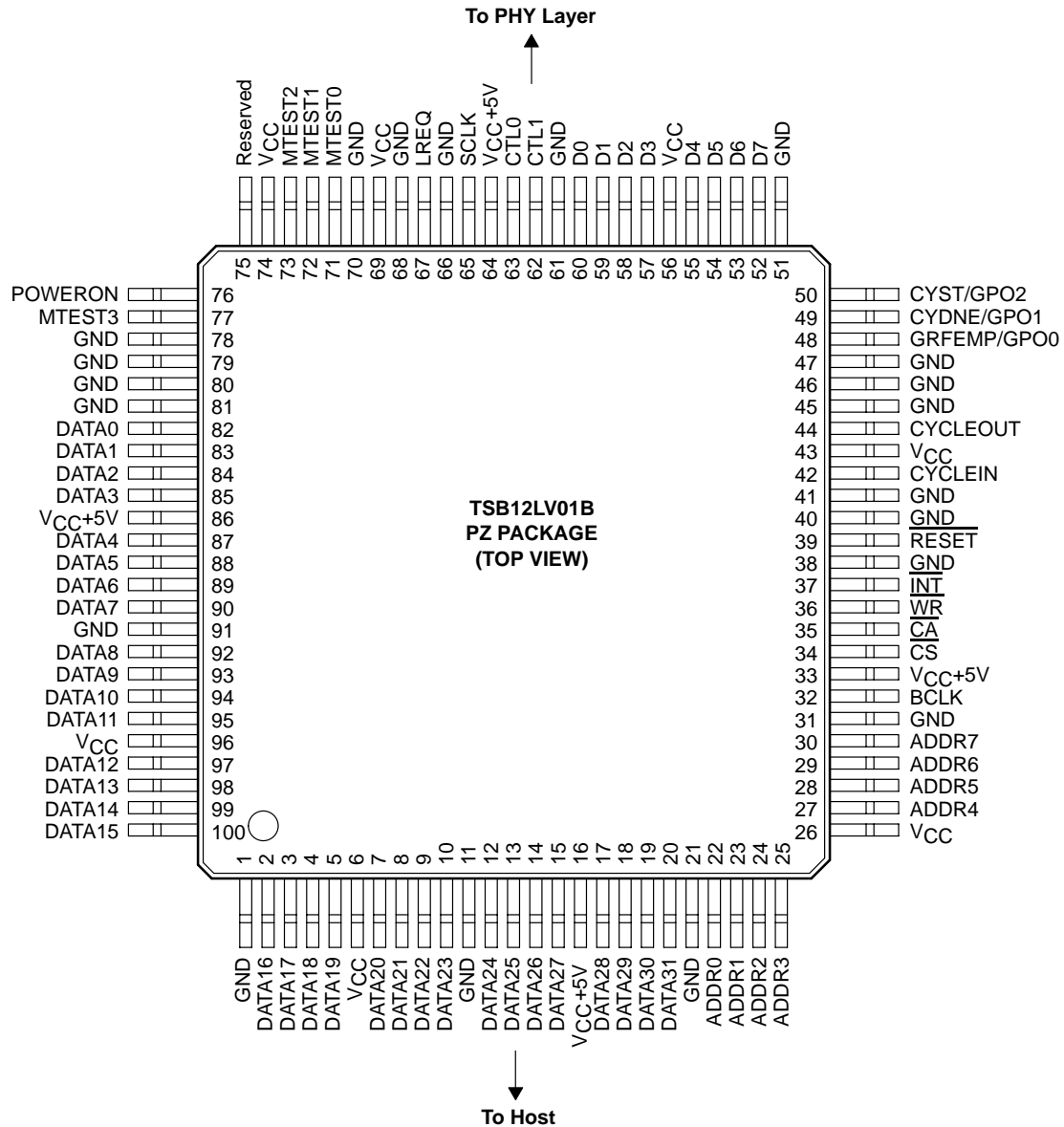

- NOTES: A. Tie reserved terminals to GND.
 B. Bit 0 is the most significant bit (MSB).

1.3 Terminal Functions

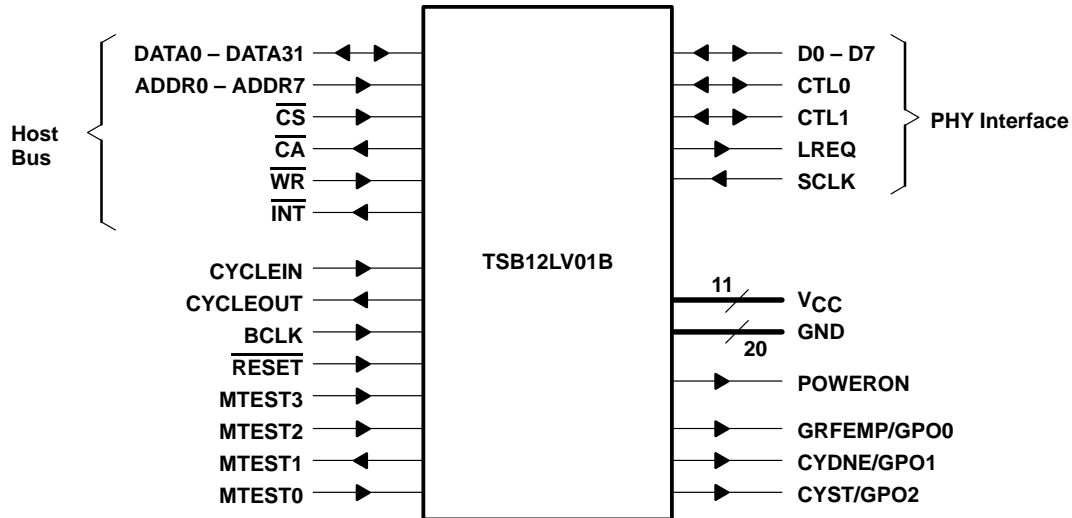

Figure 1–1. TSB12LV01B Terminal Functions

Table 1–1. Terminal Functions

TERMINAL NAME	NO.	I/O	DESCRIPTION
Host Bus Interface			
ADDR0 – ADDR7	22–25 27–30	I	Host address bus ADDR0 is the most significant bit (MSB). Address lines 6 and 7 must be grounded. (Note: FIFO space and configuration registers are quadlet-aligned.)
$\overline{\text{CA}}$	35	O	Cycle acknowledge (active low). $\overline{\text{CA}}$ is a TSB12LV01B control signal to the host bus. When asserted (low), access to the configuration registers or FIFO is complete.
$\overline{\text{CS}}$	34	I	Cycle start (active low). $\overline{\text{CS}}$ is a host bus control signal to indicate the beginning of an access to the TSB12LV01B configuration registers or FIFO space.
DATA0 – DATA31	82-85, 87-90 92-95, 97-100 2-5, 7-10 12-15, 17-20	I/O	Host data bus DATA0 is the most significant bit (MSB). Byte0 (DATA0-DATA7) is the most significant byte.
$\overline{\text{INT}}$	37	O	Interrupt (active low). When $\overline{\text{INT}}$ is asserted (low), the TSB12LV01B notifies the host bus that an interrupt has occurred.
$\overline{\text{WR}}$	36	I	Read/write enable. When $\overline{\text{CS}}$ is asserted (low) and $\overline{\text{WR}}$ is de-asserted (high), a read from the TSB12LV01B is requested by the host bus controller. To request a write access, $\overline{\text{WR}}$ must be asserted (low).

Table Terminal Functions (Continued)

TERMINAL NAME	NO.	I/O	DESCRIPTION
PHY Interface			
CTL1, CTL0	62,63	I/O	PHY-link interface control bus. CTL1 and CTL0 indicate the four operations that can occur on this interface (see Section 7 of this document or Annex J of the IEEE 1394-1995 standard for more information about the four operations).
D0 – D7	60-57 55-52	I/O	PHY-link interface data bus. Data is expected on D0 – D1 for 100 Mbits/s packets, D0 – D3 for 200 Mbits/s, and D0 – D7 for 400 Mbits/s.
LREQ	67	O	Link request to PHY. LREQ is a TSB12LV01B output that makes bus requests and register access requests to the PHY.
POWERON	76	O	Power on indicator to PHY interface. When active, POWERON has a clock output with 1/32 of the BCLK frequency and indicates to the PHY interface that the TSB12LV01B is powered up. This terminal can be connected to the link power status (LPS) terminal on the TI PHY devices to provide an indication of the LLC power condition.
SCLK	65	I	System clock. SCLK is a 49.152-MHz clock from the PHY. SCLK is used to generate the 24.576-MHz clock.
Miscellaneous Signals			
BCLK	32	I	Host bus clock. BCLK is the clock input supplied by the host to the TSB12LV01B. BCLK is asynchronous to the PHY SCLK and supports a maximum frequency of 50 MHz.
CYCLEIN	42	I	Cycle in. CYCLEIN is an optional external 8,000-Hz clock used as the cycle clock and should only be used when attached to the cycle-master node. It is enabled by the cycle source bit and should be tied high when not used. A pulsed input with a minimum pulse width of 80 ns may be used for CYCLEIN.
CYCLEOUT	44	O	Cycle out. CYCLEOUT is the TSB12LV01B version of the cycle clock. It is based on the timer controls and received cycle-start messages.
GRFEMP/GPO0	48	O	GRF Empty bit / general-purpose output 0. The power up default function for this terminal is GRFEMP. GRFEMP is asserted (high) for as long as the GRFEMP bit (bit 0 @3Ch) is set. After power up, this terminal may be programmed as a general-purpose output.
CYDNE/GPO1	49	O	CYDNE status bit / general purpose output 1. The power up default function for this terminal is CYDNE. CYDNE indicates the value of the cycle done (CyDne) bit of the interrupt register. It remains asserted (high) for as long as the interrupt bit is assigned. After power up, this terminal may be programmed as a general-purpose output.
CYST/GPO2	50	O	CYST status bit / general-purpose output 2. The power up default function for this terminal is CYST. CYST indicates the value of the cycle start (CySt) bit of the interrupt register. It remains asserted (high) for as long as the interrupt bit is assigned. After power up, this terminal may be programmed as a general-purpose output.
GND	1, 11, 21, 31, 38, 40, 41, 45–47, 51, 61, 66, 68, 70, 78–81, 91		Ground reference

Table Terminal Functions (Continued)

TERMINAL NAME	NO.	I/O	DESCRIPTION
Miscellaneous Signals (Continued)			
MTEST0	71	I	Manufacturing Test 0. This input should be grounded under normal operating conditions.
MTEST1	72	O	Manufacturing Test 1. This output should remain open under normal operating conditions.
MTEST2	73	I	Manufacturing Test 2. This input should be grounded under normal operating conditions.
MTEST3	77	I	Manufacturing Test 3. This input should be grounded under normal operating conditions.
$\overline{\text{RESET}}$	39	I	System reset (active low). /RESET is the asynchronous reset to the TSB12LV01B. It must be held low for a minimum of 2 BCLK cycles
VCC	6, 26, 43, 56 69, 74, 96	Supply	3.3-V (± 0.3 V) supply voltage
VCC (+5 V)	16, 33, 64, 86	Supply	5-V (± 0.5 V) supply voltage for 5-V tolerant inputs. These terminals should only be connected to a 5-V supply voltage if the TSB12LV01B is connected to any device driving 5-V signals. Otherwise, these terminals should be connected to the 3.3-V supply voltage. (Note: These terminals are only used to make TSB12LV01B inputs 5-V tolerant, and not to make TSB12LV01B outputs drive 5-V signals)
Reserved	75		Reserved pin. Must be tied to GND.

2 Architecture

2.1 Functional Block Diagram

The functional block architecture of the TSB12LV01B is shown in Figure 2–1.

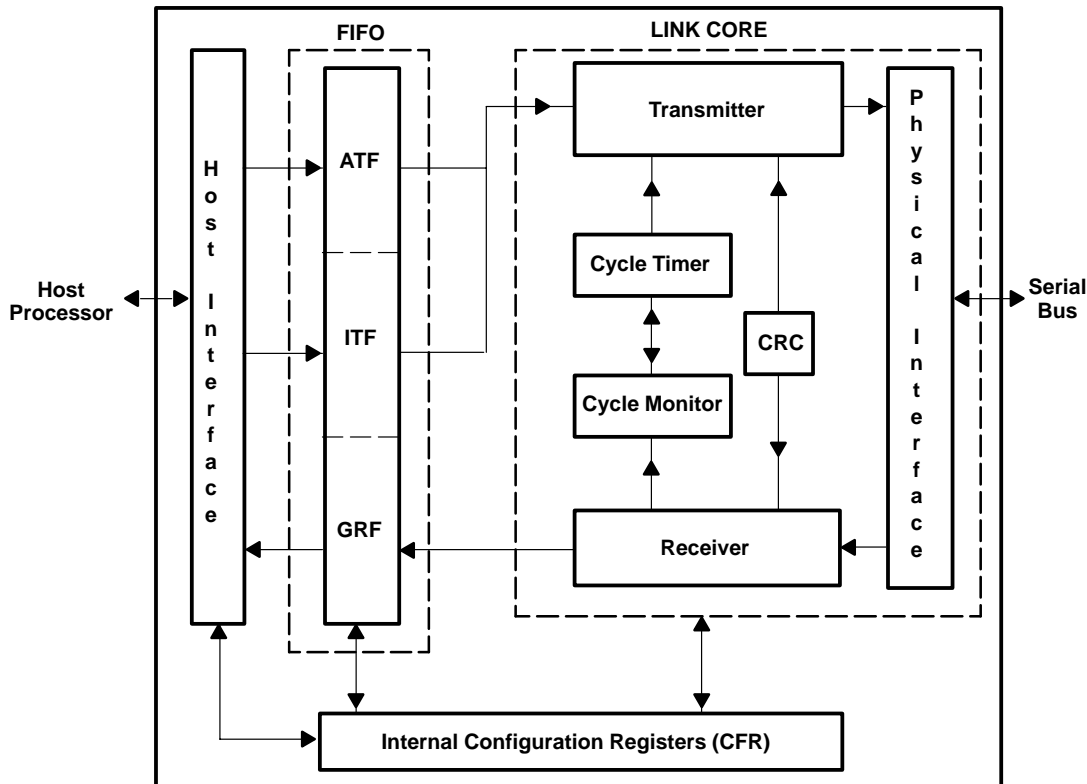

Figure 2–1. TSB12LV01B Block Diagram

2.1.1 Physical Interface

The physical (PHY) interface provides PHY-level services to the transmitter and receiver. This includes gaining access to the serial bus, sending packets, receiving packets, sending and receiving acknowledge packets, and reading and writing PHY registers.

The PHY interface module also interfaces to the PHY chip and conforms to the PHY-link interface specification described in Annex J of the IEEE 1394-1995 standard (refer to Section 7 of this document for more information).

2.1.2 Transmitter

The transmitter retrieves data from either the ATF or the ITF and creates correctly formatted serial-bus packets to be transmitted through the PHY interface. When data is present at the ATF interface to the transmitter, the TSB12LV01B PHY interface arbitrates for the serial bus and sends a packet. When data is present at the ITF interface to the transmitter, the TSB12LV01B arbitrates for the serial bus during the next isochronous cycle. The transmitter autonomously sends the cycle-start packets when the chip is a cycle master. The PHY interface provides PHY-level services to the transmitter and receiver. This includes gaining access to the serial bus, sending packets, receiving packets, and sending and receiving acknowledge packets.

2.1.3 Receiver

The receiver takes incoming data from the PHY interface and determines if the incoming data is addressed to this node. If the incoming packet is addressed to this node, the CRC of the packet is checked. If the header CRC is good, the header is confirmed in the GRF. For block and isochronous packets, the remainder of the packet is confirmed one quadlet at a time. The receiver places a status quadlet in the GRF after the last quadlet of the packet is confirmed in the GRF. The status quadlet contains the error code for the packet. The error code is the acknowledge code that was or could have been sent for that packet. For broadcast packets that do not need an acknowledge packet, the error code is the acknowledge code that would have been sent. This acknowledge code tells the transaction layer whether or not the data CRC is good or bad. When the header CRC is bad, the header is flushed and the rest of the packet is ignored. Bad packets are automatically flushed by the receiver.

When a cycle-start message is received, it is detected and the cycle-start message data is sent to the cycle timer. The cycle-start messages can be placed in the GRF like other quadlet packets.

2.1.4 Transmit and Receive FIFO Memories

The TSB12LV01B contains two transmit FIFOs (ATF and ITF) and one receive FIFO (GRF). Each of these FIFOs is one quadlet wide and their length is software-selectable. These software-selectable FIFOs allow customization of the size of each FIFO for individual applications. The sum of all FIFOs cannot be larger than 512 quadlets. The transmit FIFOs are write only from the host bus interface, and the receive FIFO is read only from the host bus interface. FIFO sizes must not be changed *on the fly*. All transactions must be ignored and FIFOs cleared before changing the FIFO sizes.

An example of how to use software-adjustable FIFOs follows:

In applications where isochronous packets are large and asynchronous packets are small, the user can set the ITF to a large size (200 quadlets each) and set the ATF to a smaller size (100 quadlets). This means 212 quadlets are allocated to the GRF. Notice that the sum of all FIFOs is equal to 512 quadlets. Only the ATF size and the ITF size can be programmed, the remaining space is assigned to the GRF.

2.1.5 Cycle Timer

The cycle timer is used by nodes that support isochronous data transfer. The cycle timer is a 32-bit cycle-timer register. Each node with isochronous data-transfer capability has a cycle-timer register as defined in the IEEE 1394-1995 standard. In the TSB12LV01B, the cycle-timer register is implemented in the cycle timer and is located in IEEE-1212 initial register space at location 200h and can also be accessed through the local bus at address 14h.

The cycle timer contains the cycle-timer register. The cycle-timer register consists of three fields: cycle offset, cycle count, and seconds count. The low-order 12 bits of the timer are a modulo 3072 counter, which increments once every 24.576-MHz clock periods (or 40.69 ns). The next 13 higher-order bits are a count of 8,000-Hz (or 125- μ s) cycles, and the highest 7 bits count seconds.

The cycle timer has two possible sources. First, if the cycle source (CySrc) bit in the configuration register is set, then the CYCLEIN input pin causes the cycle count field to increment for each positive transition of the CYCLEIN input (8 kHz) and the cycle offset resets to all zeros. CYCLEIN should only be the source when the node is cycle master. When the cycle-count field increments, CYCLEOUT is generated. The timer can also be disabled using the cycle-timer-enable bit in the control register.

The second cycle-source option is when the CySrc bit is cleared. In this state, the cycle-offset field of the cycle-timer register is incremented by the internal 24.576-MHz clock. The cycle timer is updated by the reception of the cycle-start packet for the noncycle master nodes. Each time the cycle-offset field rolls over, the cycle-count field is incremented and the CYCLEOUT signal is generated. The cycle-offset field in the cycle-start packet is used by the cycle-master node to keep all nodes in phase and running with a nominal isochronous cycle of 125 μ s. The cycle-start bit is set when the cycle-start packet is sent from the cycle-master node or received by a noncycle-master node.

2.1.6 Cycle Monitor

The cycle monitor is only used by nodes that support isochronous data transfer. The cycle monitor observes chip activity and handles scheduling of isochronous activity. When a cycle-start message is received or sent, the cycle monitor sets the cycle-started interrupt bit. It also detects missing cycle-start packets and sets the cycle-lost interrupt bit when this occurs. When the isochronous cycle is complete, the cycle monitor sets the cycle-done-interrupt bit. The cycle monitor instructs the transmitter to send a cycle-start message when the cycle-master bit is set in the control register.

2.1.7 Cyclic Redundancy Check (CRC)

The CRC module generates a 32-bit CRC for error detection. This is done for both the header and data. The CRC module generates the header and data CRC for transmitting packets and checks the header and data CRC for received packets. See the IEEE 1394-1995 standard for details on the generation of the CRC (this is the same CRC used by an IEEE802 LANs and the X3T9.5 FDDI).

2.1.8 Internal Registers

The internal registers control the operation of the TSB12LV01B.

2.1.9 Host Bus Interface

The host bus interface allows the TSB12LV01B to be easily connected to most host processors. This host bus interface consists of a 32-bit data bus and an 8-bit address bus. The TSB12LV01B utilizes cycle-start and cycle-acknowledge handshake signals to allow the local bus clock and the 1394 clock to be asynchronous to one another. The host bus interface is capable of running at speeds up to 50 MHz. All bus signal labeling on the TSB12LV01B host interface use bit#0 to denote the most significant bit (MSB). The TSB12LV01B is interrupt driven to reduce polling.

3 Internal Registers

3.1 General

The host-bus processor directs the operation of the TSB12LV01B through a set of registers internal to the TSB12LV01B itself. These registers are read or written by asserting \overline{CS} with the proper address on ADDR0 – ADDR7 and asserting or deasserting \overline{WR} depending on whether a read or write is needed. Figure 3–1 lists the register addresses; subsequent sections describe the function of the various registers.

3.2 Internal Register Definitions

The TSB12LV01B internal registers control the operation of the TSB12LV01B. The bit definitions of the internal registers are shown in Figure 3–1 and are described in subsections 3.2.1 through 3.2.12.

There are three modes to access the internal TSB12LV01B registers; normal mode, quick mode, and burst mode. The registers from address 00h to 2Ch are accessed using normal mode as shown in Figures 6–2 and 6–3.

The registers 30h, 34h, 3Ch, 40h, 44h, and C0h may be accessed using quick mode reads as shown in Figure 6–5.

The register 30h and FIFO location 80h through 9Ch may be accessed using quick mode writes as shown in Figure 6–4.

NOTE:

The protocols for normal mode and quick mode are exactly the same. The only difference being that quick mode simply returns \overline{CA} quicker.

FIFO location 84h, 8Ch, 94h, 9Ch, A0h, and B0h may be accessed using burst mode writes as shown in Figure 6–6.

The register C0h may be accessed using burst mode reads as shown in Figure 6–7.

	0	1	2	3	4	5	6	7	8	9	10	11	12	13	14	15	16	17	18	19	20	21	22	23	24	25	26	27	28	29	30	31
00h	Version (3031h)																Revision (3043h)										Version					
04h	Bus Number								Node Number				Root	Reserved						ATAck	Reserved	AckV	Node Address									
08h	IdVal	RxSlid	BsyCtrl	RAI	RcvCyst	TxAEn	RxAEn	TxlEn	RxlEn	AckCen	RstTx	RstRx	Reserved										CyMas	CySrc	CyTEn	TrgEn	Reserved			FhBad	Control	
0Ch	Int	PhInt	PhRRx	PhRst	SIDCom	TxRdy	RxDta	CmdRst	ACKRCV	ACKRCV	Reserved	ITBadF	ATBadF	Reserved	SntRj	HdrEr	TCErr	Reserved	CyTm0	CySec	CySt	CyDne	CyPnd	CyLst	CArbFI	IRP2En	Reserved	ArbGp	FrGp	IARbFI	Interrupt	
10h	Int	PhInt	PhRRx	PhRst	SIDCom	TxRdy	RxDta	CmdRst	ACKRCV	ACKRCV	Reserved	ITBadF	ATBadF	Reserved	SntRj	HdrEr	TCErr	Reserved	CyTm0	CySec	CySt	CyDne	CyPnd	CyLst	CArbFI	Reserved	ArbGp	FrGp	IARbFI	Interrupt Mask		
14h	7 Bits							Rollover @ 8000										13 Bits			Rollover @ 3072						12 Bits			Cycle Timer		
	Seconds Count							Cycle Count										Cycle Offset														
18h	TAG1		IR Port1					TAG2		IR Port2					Reserved										MonTag	Isoch Port Number						
1Ch	CLrATF	CLrITF	CLrGRF	Reserved	Trigger Size					ATFSize					ITFSize								FIFO Control									
20h	ENSp	Reserved	Reserved	regRW	Reserved																					Diagnostics						
24h	RdPhy	WrPhy	Reserved	PhyRgAd					PhyRgData					Reserved			PhyRxAd			PhyRxData			PHY Chip Access									
28h	Reserved																															Reserved
2Ch	Reserved																															Reserved
30h	Full	Empty	ConErr	AdrClr	Control	RAMTest	AdrCounter					Reserved					ATFSpaceCount								ATF Status (Read/Write)							
34h	Full	Empty	Reserved										ITFSpaceCount								ITF Status (Read Only)											
38h	Reserved																															Reserved
3Ch	Empty	cd	PacCom	GRFTotalCnt					GRFSize					WriteCount								GRF Status (Read Only)										
40h	AccFI	AccFM	LPS	SRst	Reserved																					Host Control (see Note B)						
44h	Reserved					GPO2					Reserved			GPO1			Reserved			GPO0			Mux Control (see Note B)									

NOTES: A. All gray areas (bits) are reserved bits.
 B. This register is new to the TSB12LV01B and does not exist in the TSB12LV01A.

Figure 3–1. Internal Register Map

3.2.1 Version/Revision Register (@00h)

The version/revision register allows software to be written that supports multiple versions of the high-speed serial-bus link-layer controllers. This register is at address 00h and is read only. The initial value is 3031_3043h.

Table 3–1. Version/Revision Register Field Descriptions

BITS	ACRONYM	FUNCTION NAME	DESCRIPTION
0–15	Version	Version	Version of the TSB12LV01B
16–31	Revision	Revision	Revision of the TSB12LV01B

3.2.2 Node-Address/Transmitter Acknowledge Register (@04h)

The node-address/transmitter acknowledge register controls which packets are accepted/rejected, and it presents the last acknowledge received for packets sent from the ATF. This register is at offset 04h. The bus number and node number fields are read/write. The AT acknowledge (ATAck) received is normally read only. Setting the regRW bit in the diagnostic register makes these fields read/write. Every PHY register 0 status transfer to the TSB12LV01B automatically updates the node number field and the root field. The *initial value is FFFF_0000h*.

Table 3–2. Node-Address/Transmitter Acknowledge Register Field Descriptions

BITS	ACRONYM	FUNCTION NAME	DESCRIPTION
0–9	BusNumber	Bus number	BusNumber is the 10-bit IEEE 1212 bus number that the TSB12LV01B uses with the node number in the SOURCE address for outgoing packets and to accept or reject incoming packets. The TSB12LV01B always accepts packets with a bus number equal to 3FFh.
10–15	NodeNumber	Node number	NodeNumber is the 6-bit node number that the TSB12LV01B uses with the bus number in the source address for outgoing packets and to accept or reject incoming packets. The TSB12LV01B always accepts packets with the node address equal to 3Fh. After bus reset, the node number is automatically set to the node's Physical_ID by a PHY register 0 transfer.
16	Root	Root	If Root =1 this node is root. This bit is Read only.
17–22	Reserved	Reserved	Reserved
23–27	ATAck	Address transmitter acknowledge received	ATAck is the last acknowledge received by the transmitting node in response to a packet sent from the asynchronous transmit-FIFO. ATAck=0_XXXX =>The low order 4 bits present normal Ack Code receive from the receiving node. ATAck=1_0000 => An acknowledge timeout occurred. ATAck=1_0011 => Ack packet error (ack parity error, ack too long or ack too short).
28–30	Reserved	Reserved	Reserved
31	AckV	Acknowledge valid	Whenever an ack packet is received, AckValid is set to 1. After the node-address/transmitter acknowledge register is read, AckValid is automatically reset to 0. This bit is also used to indicate arbitration failure. If a nonbroadcast asynchronous packet is in the ATF ready to transmit and a TxRdy interrupt occurs, and AckValid is 0, this indicates no ack packet was received and no ack time-out occurred. The packet is still in the ATF and the TSB12LV01B automatically arbitrates for the bus again. Under normal conditions AckValid = 0 means ATAck contains last received ack code information.

3.2.3 Control Register (@08h)

The control register dictates the basic operation of the TSB12LV01B. This register is at address 08h and is read/write. The initial value is 0000_0000h.

Table 3–3. Control-Register Field Descriptions

BITS	ACRONYM	FUNCTION NAME	DESCRIPTION
0	IdVal	ID valid	When IdVal is set, the TSB12LV01B accepts packets addressed to the IEEE 1212 address set (Node Number) in the node-address register. When IdVal is cleared, the TSB12LV01B accepts only broadcast packets.
1	RxSId	Received self-ID packets	When RxSId is set, the self-identification packets generated by phy chips during bus initialization are received and placed into the GRF as a single packet. Each self-identification packet is composed of two quadlets, where the second quadlet is the logical inverse of the first. If ACK (4 bits) equals 1h, then the data is good. If ACK equals Dh, then the data is wrong. When RxSId is set link-on packets and PHY configuration packets are also received and placed into the GRF. For these packets, only the first quadlet of each packet is stored in the GRF.
2	BsyCtrl	Busy control	When this bit is set, this node sends an ack_busy_x acknowledge packet in response to all received nonbroadcast asynchronous packets. When this bit is cleared, this node sends an ack_busy_x acknowledge packet only if the GRF is full (i.e., normal operation).
3	RAI	Received all isochronous packets	If RAI = 1 and RxIEn = 1, the TSB12LV01B will receive all isochronous packets into the GRF.
4	RcvCySt	Receive cycle start	If RcvCySt = 1, the TSB12LV01B will store all received cycle-start packets in the GRF.
5	TxAEn	Transmitter enable	When TxAEEn is cleared, the transmitter does not arbitrate or send asynchronous packets. After a bus reset, TxAEEn is cleared since the node number may have changed.
6	RxAEn	Receiver enable	When RxAEEn is cleared, the receiver does not receive any asynchronous packets. After a bus reset, RxAEEn is cleared since the node number may have changed.
7	TxIEn	Transmit isochronous enable	When TxIEn is cleared, the transmitter does not arbitrate or send isochronous packets.
8	RxIEn	Receive isochronous enable	When RxIEn is cleared, the receiver does not arbitrate or receive isochronous packets.
9	AckCEn	Ack complete enable	When AckCEn is set, the TSB12LV01B sends an ack_complete code (0001) to the transmit node for receiving a nonbroadcast write request packet if the GRF is not full and there is no error in the packet. When AckCEn is cleared, the TSB12LV01B sends an ack_pending code (0010) for the above condition.
10	RstTx	Reset transmitter	When RstTx is set, the entire transmitter resets synchronously. This bit clears itself.
11	RstRx	Reset receiver	When RstRx is set, the entire receiver resets synchronously. This bit clears itself.
12 – 19	Reserved	Reserved	Reserved

Table 3–3. Control-Register Field Descriptions (Continued)

BITS	ACRONYM	FUNCTION NAME	DESCRIPTION
20	CyMas	Cycle master	When CyMas is set and the TSB12LV01B is attached to the root phy, the cyclemaster function is enabled. When the cycle_count field of the cycle timer register increments, the transmitter sends a cycle-start packet. This bit is not cleared upon bus reset. If another node is selected as root during a bus reset, the transaction layer in the now non-root TSB12LV01B node must clear this bit.
21	CySrc	Cycle source	When CySrc is set, the cycle_count field increments and the cycle_offset field resets for each positive transition of CYCLEIN. When CySrc is cleared, the cycle_count field increments when the cycle_offset field rolls over.
22	CyTEn	Cycle-timer enable	When CyTEn is set, the cycle_offset field increments. This bit must be set to transmit cycle-start packets if node is cycle master.
23	TrgEn	Trigger size function enable	If TrgEn is set, the receiver will partition the received packet into trigger size blocks. Trigger size is defined in the FIFO Control register. The purpose of the trigger size function is to allow the receiver to receive a packet larger than the GRF size. The host bus can read the received data when each block is available without waiting for the whole packet to be loaded into the GRF. Host bus latency is therefore reduced.
24	IRP1En	IR port 1 enable	When IRP1En is set, the receiver accepts isochronous packets when the channel number matches the value in the IR Port1 field @ address 18h.
25	IRP2En	IR port 2 enable	When IRP2En is set, the receiver accepts isochronous packets when the channel number matches the value in the IR Port2 field @ address 18h.
26 – 30	Reserved	Reserved	Reserved
31	FhBad	Flush Bad Packets	When FhBad is set, the receiver flushes any received bad packets (including a partial packet due to a GRF full condition) and does not generate a RxDta interrupt. Setting FhBad also disables the TrgEn function.

3.2.4 Interrupt and Interrupt-Mask Registers (@0Ch, @10h)

The interrupt and interrupt-mask registers work in tandem to inform the host bus interface when the state of the TSB12LV01B changes. The interrupt mask register is read/write. When regRW (in the diagnostics register @20h) is cleared to 0, the interrupt register (except for the Int bit) is cleared. When regRW is set to 1, the interrupt register (including the Int bit) is read/write.

The interrupt bits all work the same. For example, when a PHY interrupt occurs, the PhInt bit is set. If the PhIntMask bit is set, the Int bit is set. If the IntMask is set, the INT signal is asserted. The logic for the interrupt bits is shown in Figure 3–2. Table 3–4 defines the interrupt and interrupt-mask register field descriptions. As shown in Figure 3–2, the INT bit is the OR of interrupt bits 1 – 31. When all the interrupt bits are cleared, INT equals 0. When any of the interrupt bits are set, INT is set 1, even if the INT bit was just cleared.

To reset the interrupt register, the host controller needs to write back the last value read. For example, if '3A7B00CF'h was read from the interrupt register, in order to cause all bits to reset to 0, the host controller must write a '3A7B00CF'h to the interrupt register.

The interrupt register initial value is 1000_0000h

The interrupt mask register initial value is 0000_0000h

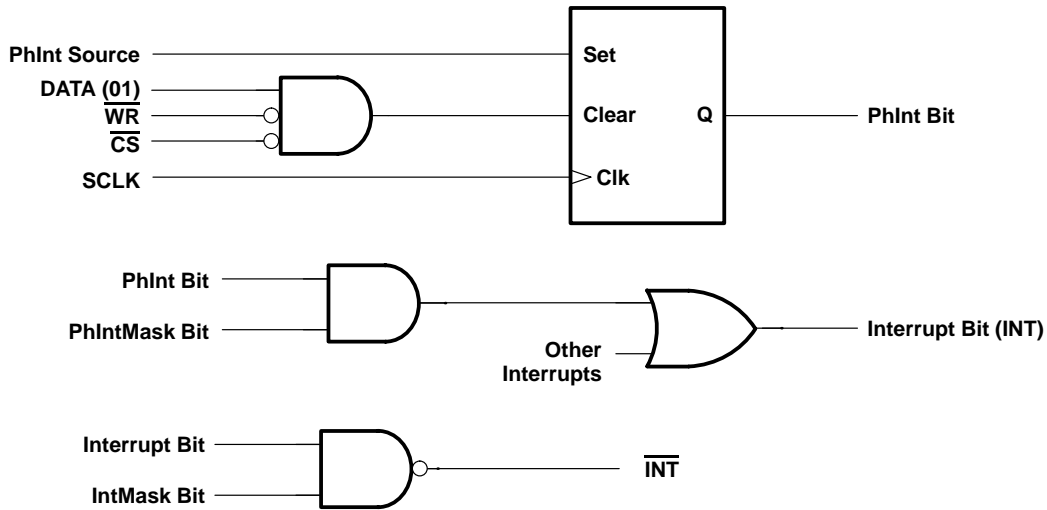

Figure 3-2. Interrupt Logic Diagram Example

Table 3-4. Interrupt- and Mask-Register Field Descriptions

BITS	ACRONYM	FUNCTION NAME	DESCRIPTION
0	Int	Interrupt	Int contains the value of all interrupt and interrupt mask bits ORed together.
1	PhInt	Phy chip interrupt	When PhInt is set, the PHY chip has signaled an interrupt through the PHY interface.
2	PhyRRx	Phy register information received	When PhyRRx is set, a register value has been transferred to the PHY chip access register (offset 24h) from the phy interface.
3	PhRst	Phy reset started	When PhRst is set, a PHY-layer reconfiguration has started (1394 bus reset).
4	SIDComp	Self ID Complete	When SIDComp is set, a complete bus reset process is finished. If the RxSld bit of the control register (@08h) is set, the GRF contains all received self-ID packets.
5	TxRdy	Transmitter ready	When TxRdy is set, the transmitter is idle and ready. If TxRdy is set to 1, and AckV (bit 31 @04h) remains 0 for a nonbroadcast asynchronous packet, the transmitter failed arbitration and will arbitrate for the bus again when the bus is idle.
6	RxDta	Receiver has data	In normal mode and when set, RxDta indicates that the receiver has accepted a block of data (if TrgEn = 0, a block of data means a packet) into the GRF interface. However, during the self-ID portion of a bus reset, this bit is set after each self-ID process is done.
7	CmdRst	Command reset received	When CmdRst is set, the receiver has been sent a quadlet write request addressed to the RESET_START CSR register.
8	ACKRCV	Receive ACK packet Interrupt	This interrupt is triggered when an acknowledge packet is received or a timeout has occurred after an asynchronous packet is sent. To enable this register, the mask interrupt should be set to 1.
9 – 10	Reserved	Reserved	Reserved

Table 3–4. Interrupt- and Mask-Register Field Descriptions (Continued)

BITS	ACRONYM	FUNCTION NAME	DESCRIPTION
11	ITBadF	Bad packet formatted in ITF	When ITBadF is set, the transmitter has detected invalid data at the isochronous transmit-FIFO interface.
12	ATBadF	Bad packet formatted in ATF	When ATBadF is set, the transmitter has detected invalid data at the asynchronous transmit-FIFO interface. If the first quadlet of a packet is not written to the ATF_First or ATF_First&Update address, the transmitter enters a state denoted by an ATBadF interrupt. An underflow of the ATF also causes an ATBadF interrupt. If this state is entered, no asynchronous packets can be sent until the ATF is cleared by way of the CLR ATF control bit. Isochronous packets can be sent while in this state.
13	Reserved	Reserved	Reserved
14	SntRj	Busy acknowledge sent by receiver	SntRj is set when a GRF overflow condition occurs. The receiver is then forced to send a busy acknowledge packet in response to a packet addressed to this node.
15	HdrEr	Header error	When HdrEr is set, the receiver detected a header CRC error on an incoming packet that may have been addressed to this node. The packet is discarded.
16	TCErr	Transaction code error	When TCErr is set, the transmitter detected an invalid transaction code in the data at the transmit FIFO interface.
17 – 18	Reserved	Reserved	Reserved
19	CyTmOut	Cycle timer out	The Isochronous cycle lasts for more than the nominal 125 μ s.
20	CySec	Cycle second incremented	When CySec is set, the cycle-second field in the cycle-timer register is incremented. This occurs approximately every second when the cycle timer is enabled.
21	CySt	Cycle started	When CySt is set, the transmitter has sent or the receiver has received a cycle-start packet.
22	CyDne	Cycle done	When CyDne is set, a subaction gap has been detected on the bus after the transmission or reception of a cycle-start packet. This indicates that the isochronous cycle is over.
23	CyPnd	Cycle pending	When CyPnd is set, the cycle-timer offset is set to 0 (rolled over or reset) and remains set until the isochronous cycle ends.
24	CyLst	Cycle lost	When CyLst is set, the cycle timer has rolled over twice without the reception of a cycle-start packet. This occurs only when this node is not the cycle master.
25	CArbFI	Cycle arbitration failed	When CArbFI is set, the arbitration to send the cycle-start packet has failed.
26 – 28	Reserved	Reserved	Reserved
29	ArbGp	Arbitration gap	Arbitration gap occurred
30	FrGp	Subaction gap	Subaction gap occurred
31	IArbFI	Isochronous arbitration failed	When IArbFI is set, the arbitration to send an isochronous packet has failed.

3.2.5 Cycle-Timer Register (@14h)

The cycle-timer register contains the seconds_count, cycle_count and cycle_offset fields of the cycle timer. This register is controlled by the cycle master, cycle source, and cycle timer enable bits of the control register. This register is read/write and must be written to as a quadlet. The initial value of the Cycle-Timer register is 0000_0000h.

Table 3–5. Cycle-Timer Register Field Descriptions

BITS	ACRONYM	FUNCTION NAME	DESCRIPTION
0–6	seconds_count	Seconds count	1-Hz cycle-timer counter
7–19	cycle_count	Cycle count	8,000-Hz cycle-timer counter
20–31	cycle_offset	Cycle offset	24.576-MHz cycle-timer counter

3.2.6 Isochronous Receive-Port Number Register (@18h)

The isochronous receive-port number register controls which isochronous channels are received by this node. If the RAI bit of the control register is set, this register value is a *don't care* since all channels are received. The register is read/write. The initial value of the Isochronous Receive-Port Number register is 0000_0000h.

Table 3–6. Isochronous Receive-Port Number Register Field Descriptions

BITS	ACRONYM	FUNCTION NAME	DESCRIPTION
0–1	TAG1	Tag bit 1	Isochronous data format tag. See IEEE 1394-1995 6.2.3 and IEC 61883.
2–7	IRPort1	Isochronous receive TAG bits and port 1 channel number	IRPort1 contains the channel number of the isochronous packets the receiver accepts when IRP1En is set. See Table 4–5 and Table 4–6 for more information.
8–9	TAG2	Tag bit 2	Isochronous data format tag. See IEEE 1394-1995 6.2.3.
10–15	IRPort2	Isochronous receive TAG bits and port 2 channel number	IRPort2 contains the channel number of the isochronous packets the receiver accepts when IRP2En is set (bits 8 and 9 are reserved as TAG bits). See Table 4–5 and Table 4–6 for more information.
16–30	Reserved	Reserved	Reserved
31	MonTag	Monitor tag enable	When MonTag is set, the tag bit comparison is enabled. If both TAGx and IRPortx match for port number x, the matching receive isochronous packet is stored in the GRF.

3.2.7 FIFO Control Register (@1Ch)

The FIFO control register is used to clear the ATF, ITF, GRF, and set up a trigger size for the trigger-size function. ATF size and ITF size fields are all specified in terms of quadlets.

GRF Size = [512–(ATF size) – (ITF size)] quadlets. This register is read/write. The initial value of this register is 0000_0000h.

Table 3–7. Node-Address/Transmitter Acknowledge Register Field Descriptions

BITS	ACRONYM	FUNCTION NAME	DESCRIPTION
0	ClrATF	Clear asynchronous transfer FIFO	Writing 1 to this bit automatically clears the ATF to 0. This bit is self clearing.
1	ClrITF	Clear isochronous transfer FIFO	Writing 1 to this bit automatically clears the ITF to 0. This bit is self clearing.
2	ClrGRF	Clear general receive FIFO	Writing 1 to this bit automatically clears the GRF to 0. This bit is self clearing.
3–4	Reserved	Reserved	Reserved

Table 3–7. Node-Address/Transmitter Acknowledge Register Field Descriptions (Continued)

BITS	ACRONYM	FUNCTION NAME	DESCRIPTION
5–13	Trigger Size	Trigger size in quadlets	Trigger size is used to partition a received packet into several smaller blocks of data. For example: if trigger size = 8, total received packet size (excluding header CRC and data CRC) = 20 quadlets, the receiver creates 3 blocks of data in the GRF. Each block starts with a packet token quadlet to indicate how many quadlets follow this packet token. The first and the second block have 9 quadlets (counting the packet token quadlet). The third block has 5 quadlets (including a packet token quadlet). Each block triggers one RxData interrupt. The purpose of the trigger size function is to allow the receiver to receive a packet larger than the GRF size. The host bus can read the received data when each block is available without waiting for the whole packet to be loaded into the GRF. Host bus latency is therefore reduced. If TrgEn bit is 0 or FhBad bit is 1 in the control register, the trigger size is ignored.
14–22	ATFSize	Asynchronous transmitter FIFO size	ATFSize allocates ATF space size in quadlets. ATFSize must be less than or equal to 512, and total transmit FIFO space (ATFSize + ITFSize) must also be less than or equal to 512.
23–31	ITFSize	Isochronous transmitter FIFO size	ITFSize allocates ITF space size in quadlets. ITFSize must be less than or equal to 512, and total transmit FIFO space (ATFSize + ITFSize) must also be less than or equal to 512.

3.2.8 Diagnostic Control Register (@20h)

The diagnostic control and status register allows for the monitoring and control of the diagnostic features of the TSB12LV01B. The regRW and ENSp bits are read/write. When regRW is cleared, all other bits are read only. When regRW is set, all bits are read/write.

The initial value of the diagnostic control and status register is 0000_0000h.

Table 3–8. Diagnostic Control and Status-Register Field Descriptions

BITS	ACRONYM	FUNCTION NAME	DESCRIPTION
0	ENSp	Enable snoop	When ENSp is set, the receiver accepts all packets on the bus regardless of the address or format. The receiver uses the snoop data format defined in Section 4.4.
1–3	Reserved	Reserved	Reserved
4	regR/W	Register read/write access	When regR/W is set, most registers become fully read/write.
5–31	Reserved	Reserved	Reserved

3.2.9 PHY-Chip Access Register (@24h)

The PHY-chip access register allows access to the registers in the attached PHY chip. The most significant 16 bits send read and write requests to the PHY-chip registers. The least significant 16 bits are for the PHY-chip to respond to a read request sent by the TSB12LV01B. The PHY-chip access register also allows the PHY-interface to send important information back to the TSB12LV01B. When the PHY-interface sends new information to the TSB12LV01B, the PHY register-information-receive (PhyRRx) interrupt is set. The register is at address 24h and is read/write. The initial value of the PHY-chip access register is 0000_0000h.

Table 3–9. PHY-Chip Access Register

BITS	ACRONYM	FUNCTION NAME	DESCRIPTION
0	RdPhy	Read PHY-chip register	When RdPhy is set, the TSB12LV01B sends a read register request with address equal to phyRgAd to the PHY interface. This bit is cleared when the request is sent.
1	WrPhy	Write PHY-chip register	When WrPhy is set, the TSB12LV01B sends a write register request with an address equal to phyRgAd on to the PHY interface. This bit is cleared when the request is sent.
2–3	Reserved	Reserved	Reserved
4–7	PhyRgAd	PHY-chip-register address	PhyRgAd is the address of the PHY-chip register that is to be accessed.
8–15	PhyRgData	PHY-chip-register data	PhyRgData is the data to be written to the PHY-chip register indicated in PhyRgAd.
16–19	Reserved	Reserved	Reserved
20–23	PhyRxAd	PHY-chip-register-received address	PhyRxAd is the address of the register from which PhyRxData came.
24–31	PhyRxData	PHY-chip-register-received data	PhyRxData contains the data from register addressed by PhyRxAd.

3.2.10 Asynchronous Transmit-FIFO (ATF) Status Register (@30h)

The ATF status register allows access to the registers that control or monitor the ATF. The register is at address 30h. All the FIFO flag bits are read only, and the FIFO control bits are read/write. This register provides RAM test mode control and status signals. In a RAMTest read/write mode, the following steps should be followed:

1. Enable RAMTest mode by setting the RAMTest bit (bit 5 in this register)
2. Set the AdrClr bit in order to clear the RAM internal address counter
3. Perform the host bus read/write access to location 80h. This accesses RAM starting at location 00h. With every read/write access, the RAM internal address counter increments by one.

The initial value of this register is 0000_0000h.

Table 3–10. ATF Status Register

BITS	ACRONYM	FUNCTION NAME	DESCRIPTION
0	Full	ATF full flag	When full is set, the FIFO is full. Write operations are ignored.
1	Empty	ATF-empty flag	When empty is set, the FIFO is empty.
2	ConErr	Control bit error	Each location in the FIFO is 33-bit wide. The MSB is called the control bit (cd bit), which is used to indicate the first quadlet of each packet in the ATF or the ITF. If the cd bit is 1, the quadlet at that location is the first quadlet of the packet in ATF or ITF, or a packet token in the GRF (packet token quadlet is defined in section 3.3.4). In RAM test mode, all FIFOs become a RAM. Control bits can be verified indirectly. If ConErr is 1, the read value of control bit does not match the write value, which is defined by the control bit (bit 4 in this register). ConErr is cleared to 0 by writing a 1 to AdrClr bit or 0 to the RAMTest bit.
3	AdrClr	Address clear control	Set AdrClr to 1 to clear AdrCounter and ConErr to 0, during the next RAM access. The RAM test mode accesses location 0. AdrClr clears itself to 0.

Table 3–10. ATF Status Register (Continued)

BITS	ACRONYM	FUNCTION NAME	DESCRIPTION
4	Control	Control bit	The value of control bit is used to relate the MSB of access RAM location in RAM test mode. For RAM test mode WRITE– control bit value concatenated with DATA0 – DATA31, writes to the location pointed by the AdrCounter. For RAM test mode READ– the read location is pointed to by the current AdrCounter. The read control counter bit is compared with control bit (bit 4) of ATF status register, if it does not match, it sets ConErr to 1.
5	RAMTest	RAM test mode	When RAM test to 1, all FIFO functions are disabled. Write to or Read from address 80h writes to or reads from the location pointed to by AdrCounter. After each write or read, the AdrCounter is incremented by 1. The AdrCounter address range is from 0 to 511. For normal FIFO operation, clear RAMTest to 0. AdrClr and AdrCounter are in a <i>don't care</i> state in this case.
6–14	AdrCounter	Address counter	Gives the address location
15–22	Reserved	Reserved	Reserved
23–31	ATFSpace-Count	ATF space count in quadlets	ATF available space for loading next packet into ATF. If ATFSpace-Count is larger than the next packet, then the software can burst write the next packet into the ATF. It only requires two host bus transactions: one ATF status read and one burst write to ATF.

3.2.11 ITF Status Register (@34h)

The ATF status register allows access to the registers that control or monitor the ATF. All the FIFO flag bits are read only, and the FIFO control bits are read/write. This register provides RAM test mode Control and status signals. The initial value of the asynchronous transmit-FIFO status register is 0000_0000h

Table 3–11. ITF Status Register

BITS	ACRONYM	FUNCTION NAME	DESCRIPTION
0	Full	ITF full flag	When full is set, the FIFO is full and all subsequent writes are ignored.
1	Empty	Empty	When empty is set, ITF is empty.
2–22	Reserved	Reserved	Reserved
23–31	ITFSpace-Count	ITF space count in quadlets	ITF available space for loading the next packet to the ITF. If ITFSpaceCount is larger than the next packet quadlet, then the software can burst write the next packet into the ITF. It only requires two host bus transactions: one ITF status read and one burst write to the ITF.

3.2.12 GRF Status Register (@3Ch)

The GRF status register allows access to the registers that control or monitor the GRF. All the FIFO flag bits are read only, and the FIFO control bits are read/write. The initial value of the GRF status register is 0000_0000h.

Table 3–12. GRF Status Register

BITS	ACRONYM	FUNCTION NAME	DESCRIPTION
0	Empty	GRF empty flag	When empty is set, the GRF is empty.
1	cd	GRF controller bit	If cd = 1, the packet token is on the top of GRF and the next GRF read will be the packet token.

Table 3–12. GRF Status Register (Continued)

BITS	ACRONYM	FUNCTION NAME	DESCRIPTION
2	PacCom	Packet complete	When cd = 1 and PacCom = 1, the next block of data from the GRF is the last one for the packet. When cd = 1 and PacComp = 0, the next block of data from the GRF is just one block for the current received packet. If the trigger size function is disabled or flush bad packet bit is set, cd = 1 and PacCom is 1. This means each received packet only contains one block of GRF data. When cd = 0 PacCom is not valid.
3–12	GRFTotal Count	Total GRF data count stored in quadlet	GRF stored data count which includes all stored received packets and internally-generated packet tokens.
13–22	GRFSize	GRF size	GRF Size = 512–(ATFSize+ITFSize) GRF Size is the total assigned space for the GRF.
23–31	WriteCount	Received data quadlet count of next block in GRF	This number is valid only when the cd bit is 1. It indicates the received data quadlet count of next block. WriteCount does not account for the packet token quadlet. The packet token is always stored on the top of each received data block to provide a status report. This allows software to burst read the next block from the GRF. If trigger-size function is disabled or flush bad received packets bit is set: To read each received packet from GRF, first read GRF status register and make sure cd = 1 so the packet token is on the top of GRF. Next perform a burst read from the GRF to read (WriteCount+1) quadlets, which includes the packet token. In cases where the trigger size function is enabled and FhBad = 0: read each block of received data as above, until PacCom is 1, which indicates that the block is the ending block of the current packet.

3.2.13 Host Control Register (@40h)

The host bus control register resides in the host processor clock (BCLK) domain. All the bits in this register are R/W with an initial value of 0000_0000'h. Table 3–13 describes the bit fields of this register.

Table 3–13. Host Control Register Description

BITS	ACRONYM	FUNCTION NAME	DESCRIPTION
0	AccsFailINT	Access failed interrupt	This bit is set when a host bus access is attempted to a register in the SCLK domain when SCLK is not running. To clear this bit, write a 1 to this bit location; a write of 0 has no effect (unless the regRW bit is set in the diagnostics register). Reset value = 0.
1	AccsFailM	Access failed interrupt mask	This bit is located in the host clock domain. If set to 1, the AccsFailINT is enabled. If set to 0, the AccsFailINT is masked off. Reset value = 0 (interrupt masked).
2	LPS_EN	LPS enable	A write of 1 to this bit will enable generation of LPS (PowerOn signal). A write of 0 has no effect on LPS_EN. This bit is cleared while SoftReset bit is set to 1. Reset value = 1.
3	SoftReset	Software reset	A write of 1 to this bit will generate a reset to the link and FIFO logic, clear TxAEn, RxAEn, TxIEn, and RxIEn in the control register, and clear LPS_EN in the this register. This bit remains set until a 0 is written to it. This bit does not change any other register values (except for the specified control register bits, and the bits effected by these bits). Reset value = 0.
4 – 31	Reserved	Reserved	Reserved

3.2.14 Mux Control Register (@44h)

The Mux control register resides in the BCLK domain. The power-up reset value of this register is 0000_0000'h. After reset the GRFEMP, CYDNE, and CYST pins will have the same functionality as the TSB12LV01A device. Tables 3–14, 3–15, and 3–16 describe the bit fields of this register. A logic high on each GPO pin indicates that the corresponding internal device event or bus event has taken place. For example, if the GPO0 field is set to '0100' and a high state is seen on pin #48 (GRFEMP/GPO0Z), the ATF full flag has been set.

Table 3–14. Mux Control Register Description (GPO0 Field)

GPO0 FIELD (BITS 28–31)				DESCRIPTION of GPO0 PIN (PIN #48)
0	0	0	0	GRFEMP (synchronous to BCLK)
0	0	0	1	CYDNE†
0	0	1	0	GRFEMP (synchronous to BCLK)
0	0	1	1	CYCLEOUT†
0	1	0	0	ATF full (synchronous to BCLK)
0	1	0	1	ATF empty (synchronous to BCLK)
0	1	1	0	ITF full (synchronous to BCLK)
0	1	1	1	ITF empty (synchronous to BCLK)
1	0	0	0	ACKRCV†
1	0	0	1	(SCLK/2)
1	0	1	0	ArbGp (synchronous to SCLK)
1	0	1	1	FrGp (synchronous to SCLK)
1	1	0	0	RxDta†
1	1	0	1	Constant zero (drive low)
1	1	1	0	Constant zero (drive low)
1	1	1	1	Constant one (drive high)

† Synchronous to (SCLK/2)

Table 3–15. Mux Control Register Description (GPO1 Field)

GPO1 FIELD (BITS 20–23)				DESCRIPTION of GPO1 PIN (PIN #49)
0	0	0	0	CYDNE
0	0	0	1	CYDNE†
0	0	1	0	GRFEMP (synchronous to BCLK)
0	0	1	1	CYCLEOUT†
0	1	0	0	ATF full (synchronous to BCLK)
0	1	0	1	ATF empty (synchronous to BCLK)
0	1	1	0	ITF full (synchronous to BCLK)
0	1	1	1	ITF empty (synchronous to BCLK)
1	0	0	0	ACKRCV†
1	0	0	1	(SCLK/2)
1	0	1	0	ArbGp (synchronous to SCLK)
1	0	1	1	FrGp (synchronous to SCLK)
1	1	0	0	RxDta†
1	1	0	1	Constant zero (drive low)
1	1	1	0	Constant zero (drive low)
1	1	1	1	Constant one (drive high)

† Synchronous to (SCLK/2)

Table 3–16. Mux Control Register Description (GPO2 Field)

GPO2 FIELD (BITS 12–15)				DESCRIPTION of GPO2 PIN (PIN #50)
0	0	0	0	CYCLEOUT
0	0	0	1	CYDNE†
0	0	1	0	GRFEMP (synchronous to BCLK)
0	0	1	1	CYCLEOUT†
0	1	0	0	ATF full (synchronous to BCLK)
0	1	0	1	ATF empty (synchronous to BCLK)
0	1	1	0	ITF full (synchronous to BCLK)
0	1	1	1	ITF empty (synchronous to BCLK)
1	0	0	0	ACKRCV†
1	0	0	1	(SCLK/2)
1	0	1	0	ArbGp (synchronous to SCLK)
1	0	1	1	FrGp (synchronous to SCLK)
1	1	0	0	RxDta†
1	1	0	1	Constant zero (drive low)
1	1	1	0	Constant zero (drive low)
1	1	1	1	Constant one (drive high)

† Synchronous to (SCLK/2)

EXAMPLE: To monitor GRFEMP, ITF full, and CYDNE on the general-purpose output pins, the following setting for the mux control register may be used:

Mux Control Register = '0 0 0 1 0 6 0 0' h

CYDNE ↗
↑
GRFEMPTY ↘
ITF full

In this case, GPO0 = '0000' b
 GPO1 = '0110' b
 GPO2 = '0001' b

3.3 FIFO Access

Access to all the transmit FIFOs is fundamentally the same; only the address to where the write is made changes.

3.3.1 General

The TSB12LV01B controller FIFO-access address map shown in Figure 3–3 illustrates how the FIFOs are mapped. The suffix `_First` denotes the FIFO location where the first quadlet of a packet should be written when the writer wants to transmit the packet. The first quadlet will be held in the FIFO until a quadlet is written to an update location.

The suffix `_Continue` denotes a write to the FIFO location where the second through n-1 quadlets of a packet could be written.

The second through n-1 quadlets are held in the FIFO until a quadlet is written to an update location.

The suffix `_Continue & Update` denotes a write to the FIFO location where the second through n quadlets of a packet could be written when the writer wants the packet to be transmitted as soon as possible. However, in this case the writes to the FIFO must be put into the FIFO faster than data is removed from the FIFO and placed on the 1394 bus, or an error will result. The last quadlet of a multiple quadlet packet should be written to the FIFO location with the notation `_Continue & Update`.

	0	1	2	3	4	5	6	7	8	9	10	11	12	13	14	15	16	17	18	19	20	21	22	23	24	25	26	27	28	29	30	31
80h	ATF_First																															} ATF Normal access FIFO Locations
84h	ATF_Continue																															
88h	Reserved																															
8Ch	ATF_Continue & Update																															
90h	ITF_First																															} ITF Normal access FIFO Locations
94h	ITF_Continue																															
98h	Reserved																															
9Ch	ITF_Continue & Update																															} ATF Burst Write
A0h	ATF_Burst_Write																															
A4h	Reserved																															
A8h	Reserved																															
AC h	Reserved																															} ITF Burst Write
B0h	ITF_Burst_Write																															
B4h	Reserved																															
B8h	Reserved																															
BC h	Reserved																															} GRF Read Location
C0h	GRF Data																															
C4h	Reserved																															
C8h	Reserved																															
CCh	Reserved																															

Figure 3–3. TSB12LV01B Controller-FIFO-Access Address Map

3.3.2 ATF Access

The procedure to access the ATF is as follows:

1. Write the first quadlet of the packet to ATF location 80h: the data is not confirmed for transmission.
2. Write the second to n-1 quadlets of the packet to ATF location 84h: Can use burst write to write (n-2) quadlets into GRF, which requires only one host write transaction, the data is not confirmed for transmission.
3. Write the final quadlet of the packet to ATF location 8Ch: It supports burst write, the data is confirmed for transmission.

If the first quadlet of a packet is not written to the ATF_First address, the transmitter enters a state denoted by an ATBadF interrupt. An underflow of the ATF also causes an ATBadF interrupt. When this state is entered, no asynchronous packets can be sent until the ATF is cleared via the CLR ATF control bit. Isochronous packets can be sent while in this state. For example, if an asynchronous write is addressed to a nonexistent address, the TSB12LV01B waits until a time out occurs and then sets ATAck (in the node address register) to 1_0000b. After the asynchronous command is sent, the sender reads ATAck. If ATAck = 1_0000b, then a time out has occurred (i.e., no response from any node was received).

ATF access example:

The first quadlet of n quadlets is written to ATF location 80h. Quadlets (2 to n-1) are written to ATF location 84h. The last quadlet (nth) is written to ATF location 8Ch. If the ATFEmpty bit is true, it is set to false and the TSB12LV01B requests the PHY layer to arbitrate for the bus. To ensure that an ATF underflow condition does not occur, loading of the ATF in this manner is suggested.

After loading the ATF with an asynchronous packet and sending it, the software driver needs to wait until the TxRdy bit (bit 5) of the interrupt register is set to 1 before reading ATAck. When TxRdy is set to 1, this indicates that the transmitter has received an ACK or time out. So the correct ATAck can then be read from the node address register. In order to receive the next Ack code, the TxRdy bit needs to be cleared to 0.

Writing to 80h (ATF_First) causes DATA0–DATA31 to be written into the ATF and sets the control bit to 1 to indicate the first quadlet of the packet, but the data is not confirmed for transmission.

It is allowed to burst write to 84h(ATF_Continue), which allows multiple quadlets to load into ATF, but the data is not confirmed for transmission.

It is allowed to burst write to 8Ch (ATF_Continue & Update), which allows multiple quadlets to load into ATF, and the data is confirmed for transmission. If consecutive writes to ATF_Continue & Update do not keep up with data being put on the 1394 bus, an ATF underflow error will occur.

Write to address A0h (ATF burst write) writes the whole packet into ATF. The first quadlet written into ATF has the control bit set to 1 to indicate this is the first quadlet of the packet, and the rest of the quadlets have the control bit set to 0. The last quadlet written into ATF confirms the packet for transmission.

To do burst write host bus master continuously drive \overline{CS} low, TSB12LV01A loads $\overline{DATA0}$ – $\overline{DATA31}$ to ATF during each rising edge of BCLK when \overline{CS} is low and at the same time it asserts \overline{CA} and \overline{CA} is one cycle behind \overline{CS} . The control bit is 0 for ATF_Continue and ATF_Continue & Update.

ATF access example:

Assume there are n quadlets need to write to ATF for transmission.

Example 3–1. Non-Burst Write

80h (ATF_First) DATA1[0:31]
84h (ATF_Continue) DATA2[0:31]
.
.
84h (ATF_Continue) DATA(n–1)[0:31]
8Ch (ATF_Continue & Update) DATAn[0:31]

Example 3–2. Allowable Burst Write

80h (ATF_First) DATA1[0:31]
84h (ATF_Continue) (burst write) DATA2[0:31], DATA3[0:31],, DATA(n–1)[0:31]
8Ch (ATF_Continue & Update) DATAn[0:31]

Example 3–3. Allowable Burst Write, But Riskier

80h (ATF_First) DATA1[0:31]
8Ch (ATF_Continue & Update) (burst write) DATA2[0:31], DATA3[0:31],, DATA(n–1)[0:31], DATAn[0:31]

NOTE:

If writes to ATF_Continued & update do not keep up with data being put on the 1394 bus, an ATF underflow error will occur.

Example 3–4. Allowable Burst Write

A0h (ATF burst write) DATA1[0:31], DATA2[0:31],, DATA(n–1)[0:31], DATAn[0:31]

Example 3–4 only requires one host bus write transaction. The packet is stored in the ATF in the following format:

{1, DATA1[0:31]}
{0, DATA2[0:31]}
{0, DATA3[0:31]}
.
.
{0, DATA(n–1)[0:31]}
{0, DATAn[0:31]}

3.3.3 ITF Access

The procedure to access to the ITF is as follows:

1. Write to ITF location 90h: the data is not confirmed for transmission (first quadlet of the packet).
2. Write to ITF location 94h: the data is not confirmed for transmission (second to n–1 quadlets of the packet). It is allowed to burst write to ITF_Continue.
3. Write to ITF location 9Ch: the data is confirmed for transmission (last quadlet of the packet). It is allowed to burst write to ITF_Continue & Update.

If the first quadlet of a packet is not written to the ITF_First, the transmitter enters a state denoted by an IFBadF interrupt. An underflow of the ITF also causes an IFBadF interrupt. When this state is entered, no isochronous packets can be sent until the ITF is cleared by the CLR ITF control bit. Asynchronous packets can be sent while in this state.

Example 3–5. ITF Access

The first quadlet of n quadlets is written to ITF location 90h. Quadlets (2 to n–1) are written to ITF location 94h. The last quadlet (nth) is written to ITF location 9Ch. If the ITFEmpty is true, it is set to false and the TSB12LV01B requests the phy layer to arbitrate for the bus. To ensure that an ITF underflow condition does not occur, loading of the ITF in this manner is suggested.

Writing to 90h(ITF_First) writes DATA0–DATA31 into the ITF and sets the control bit to 1 to indicate the first quadlet of the packet, but the data is not confirmed for transmission.

It is allowable to burst write to 94h(ITF_Continue), which allows multiple quadlets to load into ITF, but the data is not confirmed for transmission. If bursting writes to ITF_Continue & Update do not keep up with data being put on the 1394 bus, an ITF underflow error will occur.

Writing to 9Ch (ITF_Continue & Update), which allows multiple quadlets to load into ITF, the data is confirmed for transmission.

Writing to address B0h (ITF burst write) writes the whole packet into ITF. The first quadlet written into ITF has the control bit set to 1 to indicate this is the first quadlet of the packet. The termination of the burst write on the host interface confirms the packet for transmission.

ITF access example:

Assume there are n quadlets need to write to ITF for transmission.

Example 3–6. Non-Burst Write

```
90h (ITF_First)    DATA1[0:31]
94h (ITF_Continue) DATA2[0:31]
.
.
.
.
94h (ITF_Continue) DATA(n–1)[0:31]
9Ch (ITF_Continue & Update) DATAn[0:31]
```

Example 3–7. Allowable Burst Write

```
90h (ITF_First)    DATA1[0:31]
94h (ITF_Continue) (burst write) DATA2[0:31], DATA3[0:31], ..... , DATA(n–1)[0:31]
9Ch (ITF_Continue & Update) DATAn[0:31]
```

Example 3–8. Allowable Burst Write, But Riskier

```
90h (ITF_First)    DATA1[0:31]
9Ch (ITF_Continue & Update) (burst write) DATA2[0:31], DATA3[0:31], ....., DATA(n–1)[0:31],
DATAn[0:31].
```

NOTE:

If consecutive writes to ITF_Continue & Update do not keep up with data being put on the 1394 bus, an ITF underflow error will occur.

Example 3–9. Allowable Burst Write

```
B0h (ITF burst write) DATA1[0:31], DATA2[0:31], ....., DATA(n–1)[0:31], DATAn[0:31]
```

Example 3–9 only requires one host bus write transaction. The packet stores in ITF as following format:

```
{1, DATA1[0:31]}
{0, DATA2[0:31]}
{0, DATA3[0:31]}
.
.
.
{0, DATA(n–1)[0:31]}
{0, DATAn[0:31]}
```

3.3.4 General-Receive FIFO (GRF)

Access to the GRF is done with a read from the GRF, which requires a read from address C0h.

Read from the GRF can be done in burst mode. Before reading the GRF, check whether the RxDta interrupt is set, which indicates data stored in GRF is ready to read. The GRF status register may also be read and the cd bit checked if it is 1 and the write count is greater than 0. The cd bit is equal to 1 means the packet token is on top of GRF. The whole block of data contains one packet token followed by received quadlets equal to the write count.

When packet token is read, it has the following format:

- Bit 0–6 reserved
- Bit 7–10 ackSnpd. When snoop mode is enabled, this field indicates the acknowledge seen on the bus after the packet is received. If snoop mode is disabled, ackSnpd contains 4'b0.
- Bit 11 PacComp – same value as in the GRF status register when cd bit is 1. PacComp means packet complete. If PacComp is 1, this block is the last block of this packet or this block contains the whole receive packet.
- Bit 12 EnSp (bit0 of diagnostic register). If EnSp is 1, GRF contains snooped packets which includes asynchronous packets and isochronous packets. When snoop mode is enabled, all header and data CRC quadlets are stored in the GRF.
- Bit 13–14 RcvPktSpd – receive packet speed
 - 00 – 100 Mbits/s
 - 01 – 200 Mbits/s
 - 10 – 400 Mbits/s
- Bit 15–23 WriteCount – quadlet count in this block excluding packet token. WriteCount is the same number shown in GRF status register when cd bit is 1.
- Bit 24–27 Tcode – received packet tcode. For received self-ID packets, phy configuration and Link-on packets, the Tcode field contains 4'b1110 to indicate these special packets.
- Bit 28–31 Ack – Ack code sent to the transmit node for this packet when PacComp = 1. If PacComp = 0, this field is don't care. If EnSp is 1(snoop mode is enabled), this field indicates whether the entire packet snooped was correctly. For received PHY configuration and Link-on packets, this field is 4'b0000.

If trigger size function is enabled, RxDta interrupt triggers whenever each block in GRF is available for read for the same long received packet. To enable trigger size, TrgEn of control register should set to 1 , FhBad of control register should be cleared to 0 and trigger size of FIFO control register should be set to greater than 5. Therefore, the trigger size function does not apply to receive self-ID packets, PHY configuration packets, link-on packets, or quadlet read or write packets.

As an example, if a read response for data block packet is received at 400 Mbits/s, total received data is 14 quadlets excluding header CRC and data CRC, trigger size function is enabled, and trigger size is 6. The packet token is shown in hex format.

The following example generates three RxDta interrupts.

The data is stored in GRF as follows:

```
{1, 0004_0670}    <-- first packet token, PacComp = 0
{0, quadlet_1[0:31]}
{0, quadlet_2[0:31]}
{0, quadlet_3[0:31]}
{0, quadlet_4[0:31]}
```

```

{0, quadlet_5[0:31]}
{0, quadlet_6[0:31]}
{1, 0004_0670}    <- second packet token, PacComp = 0
{0, quadlet_7[0:31]}
{0, quadlet_8[0:31]}
{0, quadlet_9[0:31]}
{0, quadlet_10[0:31]}
{0, quadlet_11[0:31]}
{0, quadlet_12[0:31]}
{1, 0014_0271}    <- the last packet token, PacComp = 1, Ack = 4'0001
{0, quadlet_13[0:31]}
{0, quadlet_14[0:31]}

```

This following example generates one RxDta interrupt. If the trigger size function is disabled, the data is stored in the GRF as follows:

```

{1, 0014_0E71}    <- packet token, PacComp = 1, WriteCount = 14, Ack = 4'0001
{0, quadlet_1[0:31]}
{0, quadlet_2[0:31]}
{0, quadlet_3[0:31]}
{0, quadlet_4[0:31]}
{0, quadlet_5[0:31]}
{0, quadlet_6[0:31]}
{0, quadlet_7[0:31]}
{0, quadlet_8[0:31]}
{0, quadlet_9[0:31]}
{0, quadlet_10[0:31]}
{0, quadlet_11[0:31]}
{0, quadlet_12[0:31]}
{0, quadlet_13[0:31]}
{0, quadlet_14[0:31]}

```

3.3.5 RAM Test Mode

The purpose of RAM test mode is to test the RAM with writes and reads. During RAM test mode, RAM, which makes up the ATF, ITF, and GRF, is accessed directly from the host bus. Different data is written to and read back from the RAM and compared with what was expected to be read back. ATF status, ITF status, and GRF status are not changed during RAM test mode, but the stored data in RAM is changed by any write transaction. To enable RAM test mode, set RAMTest bit of the ATF status register. Before beginning any read or write to the RAM, the AdrClr bit of the ATF status register should be set to clear ConErr. This action also clears the AdrClr bit.

During RAM test mode, the host bus address should be C0h. The first host bus transaction (either read or write) accesses location 0 of the RAM. The second host bus transaction accesses location 1 of the RAM. The nth host bus transaction accesses location n-1 of the RAM. After each transaction, the internal RAM address counter is incremented by one.

The RAM has 512 locations with each location containing 33 bits. The most significant bit is the control bit. When the control bit is set, that indicates the quadlet is the start of the packet. In order to set the control bit, control bit of the ATF status register has to be set. In order to clear the control bit, control bit of the ATF status register has to be cleared. When a write occurs, the 32 bits of data from the host bus is written to the low order 32 bits of the RAM and the value in control-bit1 is written to the control bit. When a read occurs, the low order 32 bits of RAM are sent to the host data bus and the control bit is compared to the control bit of the ATF status register. If the control bit and control bit of the ATF status register, ConErr of ATF status register is set. This does not stop operation and another read or write can immediately be transmitted. To clear Control_bit_err, set AdrClr of the ATF status register.

Another way to access specific location in the RAM during RAM test mode is to write desired value to AdrCounter of ATF status register. The next RAM test read or write accesses the location pointed by AdrCounter. AdrCounter contains current RAM address in RAM test mode

During RAM test mode any location inside FIFO can be accessed by writing the address to AdrCounter of ATF status register. Each read or write accesses the location pointed by AdrCounter and AdrCounter increments by 1 after each transaction. Set AdrClr of ATF status register clears the AdrCounter to 0 and clear ConErr of ATF status register to 0. Setting Control1 (bit 4) of ATF status register to 1 writes control bit with 1 for RAM test write transaction.

Set RAMTest (bit 5) of ATF status register to 1 to enable RAM Test mode. A write to Address C0h writes {Control1, DATA0–DATA31} to the location pointed by AdrCounter. A read from Address C0h reads from the location pointed by AdrCounter. Control bit value can be determined by checking ConErr (bit 2) and Control1(bit 4) of ATF status register.

Table 3–17. Control Bit Value

ConErr	Control1	Control Bit Value
1	1	0
0	1	1
1	0	1
0	0	0

Another way to read the control bit value is to read the cd bit (bit 1) of the GRF status register before reading a quadlet from address C0h in RAM test mode. The cd bit contains the control bit value pointed to by the current address counter.

ATF start address is 0. ITF start address is equal to ATF size. GRF start address is equal to (ATF size + ITF size). FIFO operation temporarily stops during RAM test mode. Clear RAMTest (bit 5) of ATF status register to 0 resumes normal FIFO operation.

4 TSB12LV01B Data Formats

The data formats for transmission and reception of data are shown in the following sections. The transmit format describes the expected organization of data presented to the TSB12LV01B at the host-bus interface. The receive formats describe the data format that the TSB12LV01B presents to the host-bus interface.

4.1 Asynchronous Transmit (Host Bus to TSB12LV01B)

Asynchronous transmit refers to the use of the asynchronous-transmit FIFO (ATF) interface. There are two basic formats for data to be transmitted. The first is for quadlet packets, and the second is for block packets. For transmits, the FIFO address indicates the beginning, middle, and end of a packet. All packet formats described in this section refer to the way the packets are stored in the internal FIFO memory of the TSB12LV01B. The host application must conform to the packet formats specified in this section when accessing the ATF for a write operation and the GRF for a read operation.

4.1.1 Quadlet Transmit

The IEEE 1394-1995 standard specified four types of quadlet transmit packets: write request, read request, write response, and read response packets. Table 4–1 describes the details of each packet.

4.1.1.1 Quadlet Write-Request and Read-Request Packets

The format for a quadlet write-request packet is shown in Figure 4–1. The first quadlet contains the packet control information. The second and third quadlets contain the 64-bit, quadlet-aligned destination address. The fourth quadlet is the quadlet data used. The format for a quadlet read-request packet is shown in Figure 4–2.

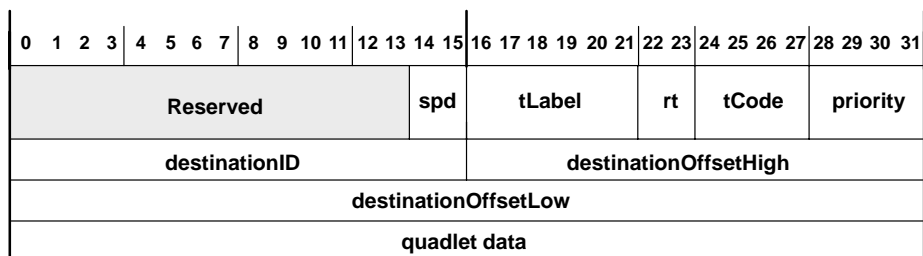

Figure 4–1. Quadlet-Transmit Format (Write Request)

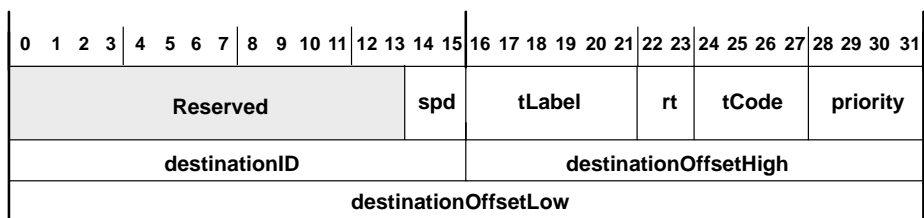

Figure 4–2. Quadlet-Transmit Format (Read Request)

4.1.1.2 Quadlet Read-Response and Write Response Packets

The format for a quadlet read-response packet is shown in Figure 4–3. The first quadlet contains the packet control information. The first 16 bits of the second quadlet is the destination identifier, which is the address of the destination or requesting node. The second quadlet also contains the response code of this transaction. The third quadlet is reserved. The fourth quadlet is the quadlet data used. The format for a quadlet write-response packet is shown in Figure 4–4.

0	1	2	3	4	5	6	7	8	9	10	11	12	13	14	15	16	17	18	19	20	21	22	23	24	25	26	27	28	29	30	31
Reserved												spd	tLabel			rt	tCode			priority											
destinationID												rCode			reserved																
RESERVED																															
quadlet data																															

Figure 4–3. Quadlet-Transmit Format (Read Response)

0	1	2	3	4	5	6	7	8	9	10	11	12	13	14	15	16	17	18	19	20	21	22	23	24	25	26	27	28	29	30	31
Reserved												spd	tLabel			rt	tCode			priority											
destinationID												rCode			reserved																
RESERVED																															

Figure 4–4. Quadlet-Transmit Format (Write Response)

Table 4–1. Quadlet-Transmit Format

FIELD NAME	DESCRIPTION		
spd	The spd field indicates the speed at which the current packet is to be sent (00 = 100 Mbits/s, 01 = 200 Mbits/s, and 10 = 400 Mbits/s, and 11 is undefined).		
tLabel	The tLabel field is the transaction label, which is a unique tag for each outstanding transaction between two nodes. This field is used to pair up a response packet with its corresponding request packet.		
rt	The rt field is the retry code for the current packet is: 00 = new, 01 = retry_X, 10 = retryA, and 11 = retryB.		
tCode	The tCode field is the transaction code for the current packet (see Table 6–10 of IEEE 1394-1995 standard).		
priority	The priority field contains the priority level for the current packet. For cable implementation, the value of the bits must be zero (for backplane implementation, see clause 5.4.1.3 and 5.4.2.1 of the IEEE 1394-1995 standard).		
destinationID	The destinationID field is the concatenation of the 10-bit bus number and the 6-bit node number that forms the destination node address of the current packet.		
rCode	Specifies the result of the read request transaction. The response codes that may be returned to the requesting agent are defined as follows:		
	Response Code	Name	Description
	0	resp_complete	Node successfully completed requested operation.
	1–3	Reserved	
	4	resp_conflict_error	Resource conflict detected by responding agent. Request may be retried.
	5	resp_data_error	Hardware error. Data not available.
	6	resp_type_error	Field within request packet header contains unsupported or invalid value.
	7	resp_address_error	Address location within specified node not accessible.
8 – Fh	Reserved		
destination OffsetHigh, destination OffsetLow	The concatenation of these two fields addresses a quadlet in the destination node address space. This address must be quadlet aligned (modulo 4).		
quadlet data	For write requests and read responses, the quadlet data field holds the data to be transferred. For write responses and read requests, this field is not used and should not be written into the FIFO.		

4.1.2 Block Transmit

The IEEE 1394–1995 standard specified four types of block transmit packets: write request, write response, read request, and read response packet. Table 4–2 describes the details of each packet.

4.1.2.1 Block Write-Request and Read-Request packets

The format for a block write-request packet is shown in Figure 4–5. The first quadlet contains the packet control information. The second and third quadlets contain the 64-bit, quadlet-aligned address. The first 16 bits of the fourth quadlet contains the dataLength field. This is the number of bytes of data in the packet. The remaining 16 bits represent the extended_tCode field (see Table 6–11 of the IEEE 1394-1995 standard for more information on extended_tCodes). The block data, if any, follows the extended_tCode. The format for a block read-request is shown in Figure 4–6.

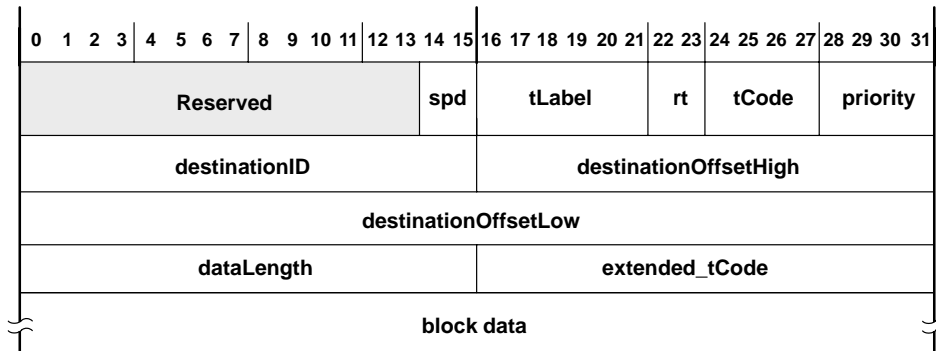

Figure 4–5. Block-Transmit Format (Write Request)

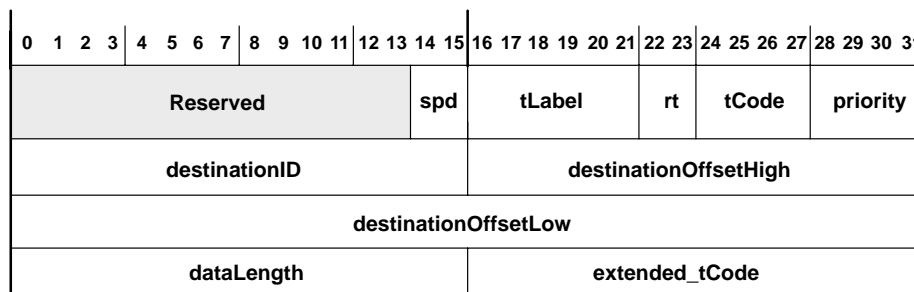

Figure 4–6. Block-Transmit Format (Read Request)

4.1.2.2 Block Read-Response and Write-Response Packets

The format for a block read-response packet is shown in Figure 4–7. The first quadlet contains the packet control information. The first 16 bits of the second quadlet is the destination identifier, which is the address of the destination or requesting node. The second quadlet also contains the response code of this transaction. The third quadlet is reserved. The first 16 bits of the fourth quadlet contains the dataLength field. This is the number of bytes of data in the packet. The remaining 16 bits represent the extended_tCode field. The block data, if any, follows the extended_tCode. The format for a block write-response is shown in Figure 4–8.

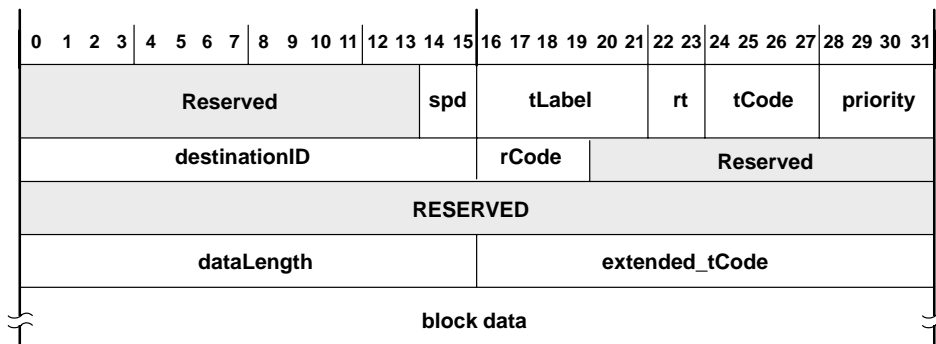

Figure 4–7. Block-Transmit Format (Read Response)

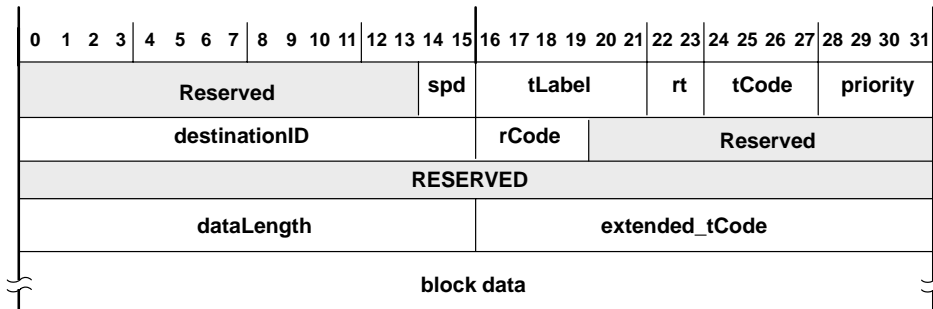

Figure 4–8. Block-Transmit Format (Write Response)

Table 4–2. Block-Transmit Format Functions

FIELD NAME	DESCRIPTION		
spd	The spd field indicates the speed at which the current packet is to be sent (00 = 100 Mbits/s, 01 = 200 Mbits/s, and 10 = 400 Mbits/s, and 11 is undefined).		
tLabel	The tLabel field is the transaction label, which is a unique tag for each outstanding transaction between two nodes. This field is used to pair up a response packet with its corresponding request packet.		
rt	The rt field is the retry code for the current packet is: 00 = new, 01 = retry_X, 10 = retryA, and 11 = retryB.		
tCode	The tCode field is the transaction code for the current packet (see Table 6–10 of IEEE 1394-1995 standard).		
priority	The priority field contains the priority level for the current packet. For cable implementation, the value of the bits must be zero (for backplane implementation, see clause 5.4.1.3 and 5.4.2.1 of the IEEE 1394-1995 standard).		
destinationID	The destinationID field is the concatenation of the 10-bit bus number and the 6-bit node number that forms the destination node address of the current packet.		
rCode	Specifies the result of the read request transaction. The response codes that may be returned to the requesting agent are defined as follows:		
	Response Code	Name	Description
	0	resp_complete	Node successfully completed requested operation.
	1–3	Reserved	
	4	resp_conflict_error	Resource conflict detected by responding agent. Request may be retried.
	5	resp_data_error	Hardware error. Data not available.
	6	resp_type_error	Field within request packet header contains unsupported or invalid value.
	7	resp_address_error	Address location within specified node not accessible.
8 – Fh	Reserved		
destination OffsetHigh, destination OffsetLow	The concatenation of these two fields addresses a quadlet in the destination node address space. This address must be quadlet aligned (modulo 4).		
dataLength	The dataLength field contains the number of data bytes to be transmitted in the packet.		
extended_tcode	The block extended_tCode to be performed on the data in the current packet (see Table 6–11 of the IEEE 1394-1995 standard).		
block data	The block data field contains the data to be sent. If dataLength is 0, no data should be written into the FIFO for this field. Regardless of the destination or source alignment of the data, the first byte of the block must appear in byte 0 of the first quadlet.		

4.2 Asynchronous Receive (TSB12LV01B to Host Bus)

The general-receive FIFO (GRF) is shared by asynchronous data and isochronous data. There are two basic formats for data to be received. The first is for quadlet packets, and the second is for block packets. For block receives, the data length, which is found in the header of the packet, determines the number of bytes in the packet. All packet formats described in this section refer to the way the packets are stored in the internal FIFO memory of the TSB12LV01B.

4.2.1 Quadlet Receive

The IEEE 1394-1995 standard specified four types of quadlet receive packets: write request, read request, write response, and read response packets. Table 4–9 describes the details of each packet.

0	1	2	3	4	5	6	7	8	9	10	11	12	13	14	15	16	17	18	19	20	21	22	23	24	25	26	27	28	29	30	31
Reserved											PacCom	spd		WriteCount				tCode		ackSent											
destinationID												tLabel			rt	tCode		priority													
sourceID												destinationOffsetHigh																			
destinationOffsetLow																															
quadlet data																															

Figure 4–9. Quadlet-Receive Format (Write Request)

4.2.1.1 Quadlet Write-Request and Read-Request Packets

The format for a quadlet write-request packet is shown in Figure 4–9. The first quadlet read from the GRF is the packet token described in section 3.3.4. It contains packet-reception status information added by the TSB12LV01B. The first 16 bits of the second quadlet contains the destination node and bus ID, and the remaining 16 bits contain the packet control information. The first 16 bits of the third quadlet contain the node and bus ID of the source, and the remaining 16 bits of the third quadlet and the entire fourth quadlet contain the 48-bit, quadlet aligned destination offset address. The fifth quadlet contains the data used by the write request packet. The format for a quadlet read-request packet is shown in Figure 4–10.

0	1	2	3	4	5	6	7	8	9	10	11	12	13	14	15	16	17	18	19	20	21	22	23	24	25	26	27	28	29	30	31
Reserved											PacCom	spd		WriteCount				tCode		ackSent											
destinationID												tLabel			rt	tCode		priority													
sourceID												destinationOffsetHigh																			
destinationOffsetLow																															

Figure 4–10. Quadlet-Receive Format (Read Request)

4.2.1.2 Quadlet Read-Response and Write-Response Packets

The format for a quadlet read-response packet is shown in Figure 4–11. The first quadlet read from the GRF is the packet token described in section 3.3.4. It contains packet-reception status information added by the TSB12LV01B. The first 16 bits of the second quadlet contains the destination node and bus ID. The second quadlet also contains the response code of this transaction. The third quadlet is reserved. The fourth quadlet is the quadlet data used. The format for a quadlet write-response packet is shown in Figure 4–12.

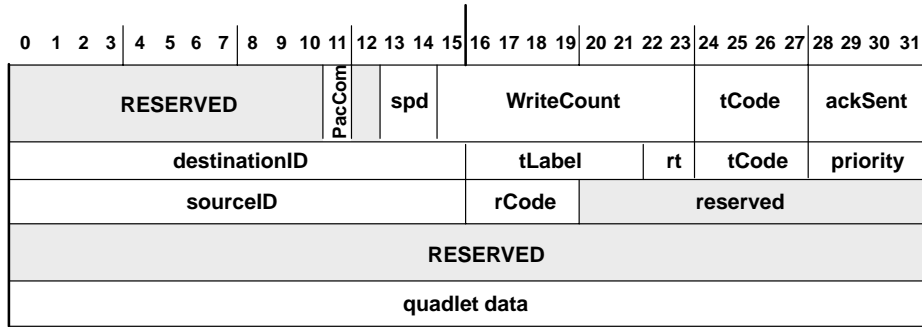

Figure 4–11. Quadlet-Receive Format (Read Response)

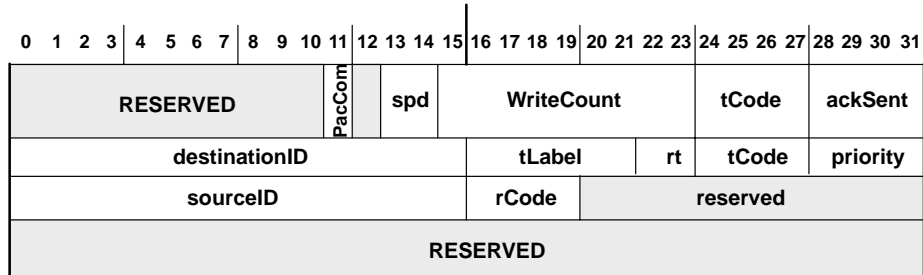

Figure 4–12. Quadlet-Receive Format (Write Response)

Table 4–3. Quadlet-Receive Format Functions

FIELD NAME	DESCRIPTION		
PacCom	Packet Complete. When PacCom = 1, the current block of data is the last one for the packet. When PacCom = 0, the current block of data is just another block of the current packet.		
spd	The spd field indicates the speed at which the current packet is to be sent (00 = 100 Mbits/s, 01 = 200 Mbits/s, and 10 = 400 Mbits/s, and 11 is undefined).		
WriteCount	WriteCount indicates the number of data quadlets in the packet.		
tCode	The tCode field is the transaction code for the current packet (See Table 6–10 of IEEE 1394-1995 standard).		
ackSent	This 5-bit field holds the acknowledge code sent by the receiver for the current packet (See Table 6–13 of the IEEE 1394-1995 standard).		
destinationID	The destinationID field is the concatenation of the 10-bit bus number and the 6-bit node number that forms the destination node address of the current packet.		
tLabel	The tLabel field is the transaction label, which is a unique tag for each outstanding transaction between two nodes. This field is used to pair up a response packet with its corresponding request packet.		
rt	The rt field is the retry code for the current packet is: 00 = new, 01 = retry_X, 10 = retryA, and 11 = retryB.		
priority	The priority field contains the priority level for the current packet. For cable implementation, the value of the bits must be zero (for backplane implementation, see clause 5.4.1.3 and 5.4.2.1 of the IEEE 1394-1995 standard).		
sourceID	This is the node ID (bus ID and physical ID) of the sender of this packet.		
destination OffsetHigh, destination OffsetLow	The concatenation of these two fields addresses a quadlet in the destination node address space. This address must be quadlet aligned (modulo 4).		
rCode	Specifies the result of the read request transaction. The response codes that may be returned to the requesting agent are defined as follows:		
	Response Code	Name	Description
	0	resp_complete	Node successfully completed requested operation.
	1–3	Reserved	
	4	resp_conflict_error	Resource conflict detected by responding agent. Request may be retried.
	5	resp_data_error	Hardware error. Data not available.
	6	resp_type_error	Field within request packet header contains unsupported or invalid value.
	7	resp_address_error	Address location within specified node not accessible.
8 – Fh	Reserved		
quadlet data	For write requests and read responses, the quadlet data field holds the data to be transferred. For write responses and read requests, this field is not used and should not be written into the FIFO.		

4.2.2 Block Receive

The IEEE 1394-1995 standard specified four types of block receive packets: write request, read request, write response, and read response packet. Refer to Table 4-4 for a description of the packet fields.

4.2.2.1 Block Write-Request and Read-Request Packets

The format for a block write-request packet is shown in Figure 4-13. The first quadlet read from the GRF is the packet token described in section 3.3.4. It contains packet-reception status information added by the TSB12LV01B. The first 16 bits of the second quadlet contains the destination node and bus ID, and the remaining 16 bits contain the packet control information. The first 16 bits of the third quadlet contain the node and bus ID of the source, and the remaining 16 bits of the third quadlet and the entire fourth quadlet contain the 48-bit, quadlet aligned destination offset address. The first 16 bits of the fifth quadlet contains the dataLength field. The remaining 16 bits represent the extended_tCode field. The block data, if any, follows the extended_tCode. The format for a block read-request packet is shown in Figure 4-14.

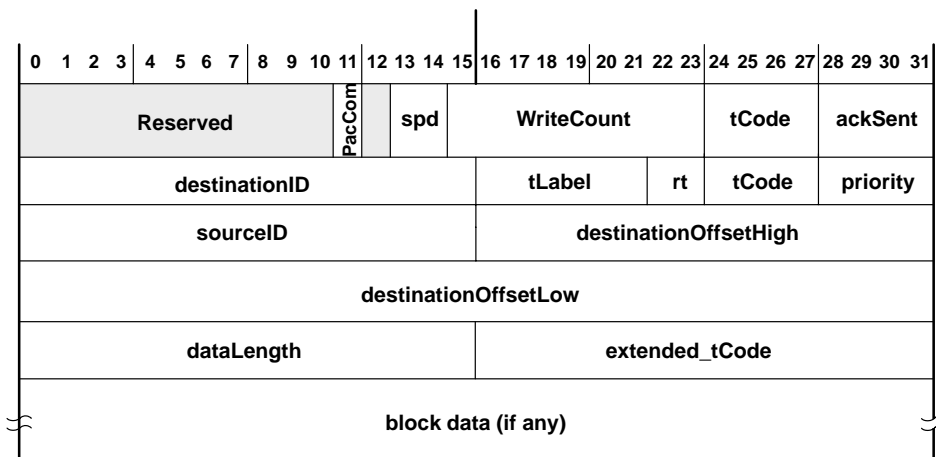

Figure 4-13. Block-Receive Format (Write Request)

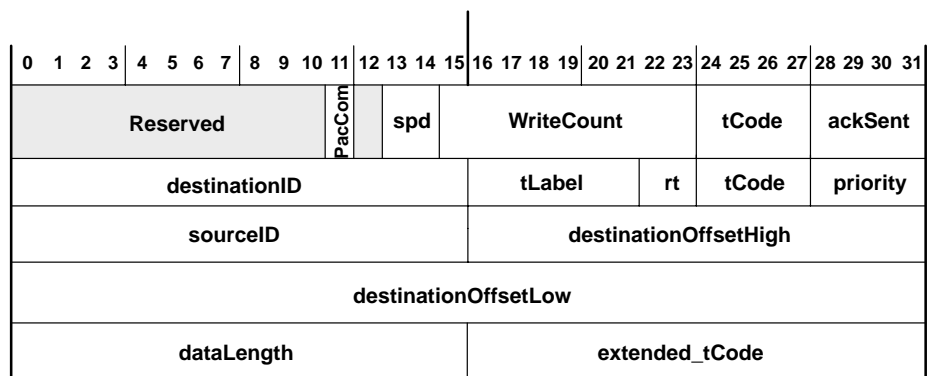

Figure 4-14. Block-Receive Format (Read Request)

4.2.2.2 Block Read-Response and Write-Response Packets

The format for a block read-response packet is shown in Figure 4–15. The first quadlet read from the GRF is the packet token described in section 3.3.4. It contains packet-reception status information added by the TSB12LV01B. The first 16 bits of the second quadlet contains the destination node and bus ID. The second quadlet also contains the response code of this transaction. The third quadlet is reserved. The first 16 bits of the fourth quadlet contains the dataLength field. The remaining 16 bits represent the extended_tCode field. The block data, if any, follows the extended_tCode. The format for a block write-response packet is shown in Figure 4–16.

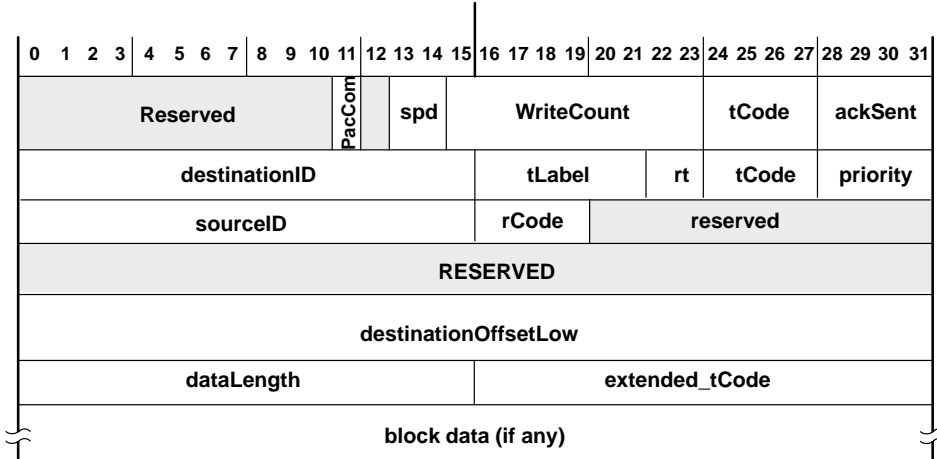

Figure 4–15. Block-Receive Format (Read Response)

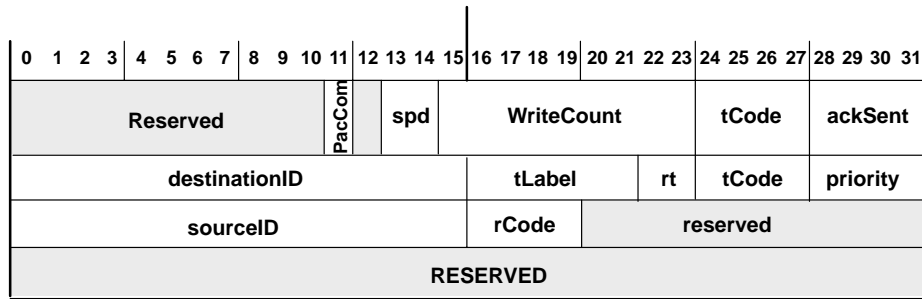

Figure 4–16. Block-Receive Format (Write Response)

Table 4–4. Block-Receive Format Functions

FIELD NAME	DESCRIPTION		
PacCom	Packet Complete. When PacCom = 1, the current block of data is the last one for the packet. When PacCom = 0, the current block of data is just another block of the current packet.		
spd	The spd field indicates the speed at which the current packet is to be sent (00 = 100 Mbits/s, 01 = 200 Mbits/s, and 10 = 400 Mbits/s, and 11 is undefined).		
WriteCount	WriteCount indicates the number of data quadlets in the packet.		
tCode	The tCode field is the transaction code for the current packet (See Table 6–10 of IEEE 1394-1995 standard).		
ackSent	This 5-bit field holds the acknowledge code sent by the receiver for the current packet (See Table 6–13 of the IEEE 1394-1995 standard).		
destinationID	The destinationID field is the concatenation of the 10-bit bus number and the 6-bit node number that forms the destination node address of the current packet.		
tLabel	The tLabel field is the transaction label, which is a unique tag for each outstanding transaction between two nodes. This field is used to pair up a response packet with its corresponding request packet.		
rt	The rt field is the retry code for the current packet is: 00 = new, 01 = retry_X, 10 = retryA, and 11 = retryB.		
priority	The priority field contains the priority level for the current packet. For cable implementation, the value of the bits must be zero (for backplane implementation, see clause 5.4.1.3 and 5.4.2.1 of the IEEE 1394-1995 standard).		
sourceID	This is the node ID (bus ID and physical ID) of the sender of this packet.		
destination OffsetHigh, destination OffsetLow	The concatenation of these two fields addresses a quadlet in the destination node address space. This address must be quadlet aligned (modulo 4).		
rCode	Specifies the result of the read request transaction. The response codes that may be returned to the requesting agent are defined as follows:		
	Response Code	Name	Description
	0	resp_complete	Node successfully completed requested operation.
	1–3	Reserved	
	4	resp_conflict_error	Resource conflict detected by responding agent. Request may be retried.
	5	resp_data_error	Hardware error. Data not available.
	6	resp_type_error	Field within request packet header contains unsupported or invalid value.
	7	resp_address_error	Address location within specified node not accessible.
8 – Fh	Reserved		
block data	The block data field contains the data to be sent. If dataLength is 0, no data should be written into the FIFO for this field. Regardless of the destination or source alignment of the data, the first byte of the block must appear in byte 0 of the first quadlet.		

4.3 Isochronous Transmit (Host Bus to TSB12LV01B)

The format of the isochronous-transmit packet is shown in Figure 4–17 and is described in Table 4–5. The data for each channel must be presented to the isochronous-transmit FIFO interface in this format in the order that packets are to be sent. The transmitter requests the bus to send any packets available at the isochronous-transmit interface immediately following reception or transmission of the cycle-start message.

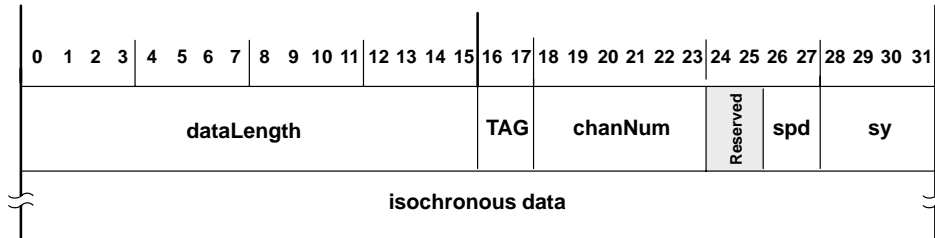

Figure 4–17. Isochronous-Transmit Format

Table 4–5. Isochronous-Transmit Functions

FIELD NAME	DESCRIPTION
dataLength	The dataLength field indicates the number of bytes in the current packet.
TAG	The TAG field indicates the format of data carried by the isochronous packet (00 = formatted, 01 – 11 are reserved).
chanNum	The chanNum field carries the channel number with which the current data is associated.
spd	The spd field indicates the speed at which the current packet is to be sent (00 = 100 Mbits/s, 01 = 200 Mbits/s, and 10 = 400 Mbits/s, and 11 is undefined).
sy	The sy field carries the transaction layer-specific synchronization bits.
isochronous data	The isochronous data field contains the data to be sent with the current packet. The first byte of data must appear in byte 0 of the first quadlet of this field. If the last quadlet does not contain four bytes of data, the unused bytes should be padded with zeros.

4.4 Isochronous Receive (TSB12LV01B to Host Bus)

The format of the isochronous-receive data is shown in Figure 4–18 and is described in Table 4–6. The data length, which is found in the header of the packet, determines the number of bytes in an isochronous packet.

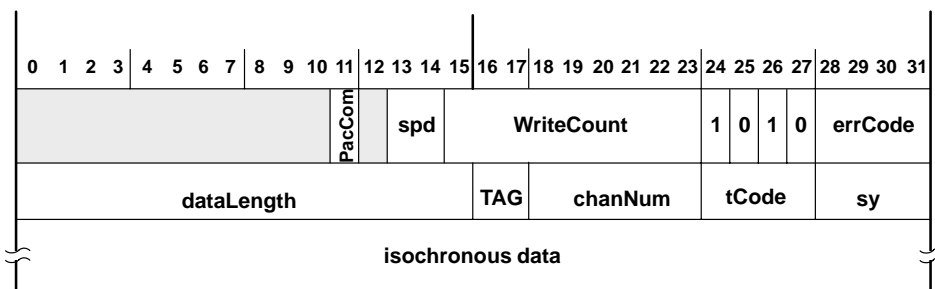

Figure 4–18. Isochronous-Receive Format

Table 4–6. Isochronous-Receive Functions

FIELD NAME	DESCRIPTION
PacCom	Packet complete. When PacCom = 1, the current block of data is the last one for the packet. When PacCom = 0, the current block of data is just another block of the current packet.
spd	The spd field indicates the speed at which the current packet is to be sent (00 = 100 Mbits/s, 01 = 200 Mbits/s, and 10 = 400 Mbits/s, and 11 is undefined).
WriteCount	WriteCount indicates the number of data quadlets in the packet.
errCode	The errCode field indicates whether the current packet has been received correctly. The possibilities are complete, DataErr, or CRCErr, and have the same encoding as the corresponding acknowledge codes (See Table 6–13 of the IEEE 1394-1995 standard).
dataLength	The dataLength field indicates the number of bytes in the current packet.
TAG	The TAG field indicates the format of data carried by isochronous packet (00 = formatted, 01 – 11 are reserved).
chanNum	The chanNum field contains the channel number with which this data is associated.
tCode	The tCode field carries the transaction code for the current packet (tCode = Ah).
sy	The sy field carries the transaction layer-specific synchronization bits.
isochronous data	The isochronous data field has the data to be sent with the current packet. The first byte of data must appear in byte 0 of the first quadlet of this field. The last quadlet should be padded with zeros.

4.5 Snoop Receive

The format of the snoop data is shown in Figure 4–19. The receiver module can be directed to receive any and all packets that pass by on the serial bus. In this mode, the receiver presents the data received to the receive-FIFO interface.

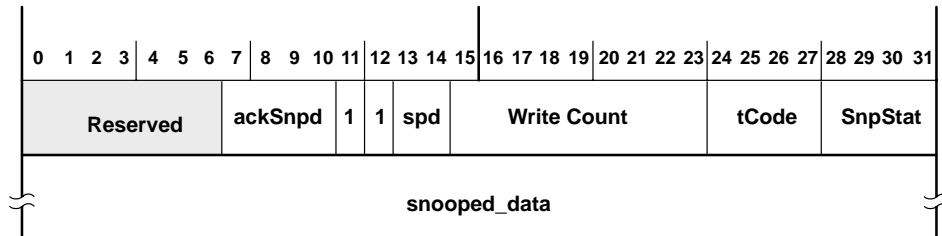

NOTES: A. Bit 11 (PacCom)=1
 B. Bit 12 (EnSp) = 1. This is bit 0 of the diagnostic register.

Figure 4–19. Snoop Format

Table 4–7. Snoop Functions

FIELD NAME	DESCRIPTION
ackSnpd	Acknowledge snooped. This field indicates the acknowledge seen on the bus after the packet is received.
spd	This field indicates the speed at which this packet was sent (00 = 100 Mbits/s, 01 = 200 Mbits/s, and 10 = 400 Mbits/s, and 11 is undefined).
WriteCount	WriteCount indicates the number of data quadlets in the packet.
tCode	The tCode field is the transaction code for the current packet (See Table 6–10 of the IEEE 1394-1995 standard).
SnpStat	This field indicates whether the entire packet snooped was received correctly. A value equal to the ack_complete acknowledge code indicates complete reception. This field has the same encoding as the corresponding acknowledge codes (See Table 6–13 of the IEEE 1394-1995 standard).
snooped_data	This field contains the entire packet received or as much as could be received into the GRF.

4.6 CycleMark

The format of the CycleMark data is shown in Figure 4–20 and is described in Table 4–8. The receiver module inserts a single quadlet to mark the end of an isochronous cycle. The quadlet is inserted into the GRF.

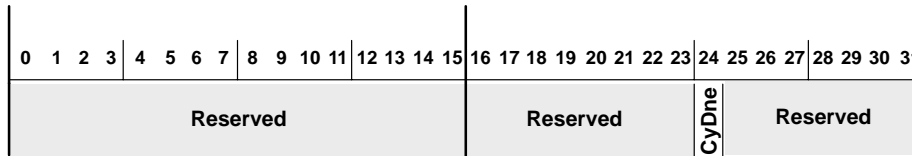

Figure 4–20. CycleMark Format

Table 4–8. CycleMark Function

FIELD NAME	DESCRIPTION
CyDne	The CyDne field indicates the end of an isochronous cycle.

4.7 PHY Configuration Transmit

The transmit format of the PHY-configuration packet is shown in Figure 4–21 and described in Table 4–9. The PHY-configuration packet contains three quadlets, which are loaded into the ATF. The first quadlet is the tCode for an unformatted packet. This is written into ATF_First at address 80h and has a value of 0000_00E0h. The second quadlet consists of actual data. This is written into the ATF_Continue at address 84h and has a value of the first quadlet of the PHY-configuration packet. The third quadlet is the logical inverse of the second quadlet and it written into the ATF_Continue&Update at address 8Ch and has a value of the second quadlet of the PHY-configuration packet.

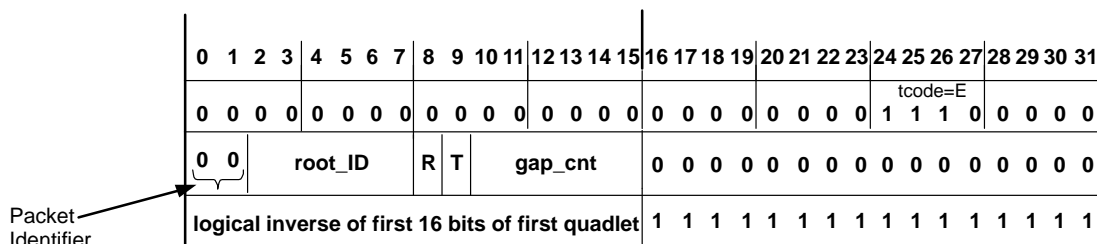

Figure 4–21. PHY-Configuration Packet Format

There is a possibility of a false header error on receipt of a PHY-configuration packet. If the first 16 bits of a PHY-configuration packet happen to match the destination identifier of a node (bus number and node number), the TSB12LV01B on that node issues a header error since the node misinterprets the PHY-configuration packet as a data packet addressed to the node. The suggested solution to this potential problem is to assign bus numbers that all have the most significant bit set to 1. Since the all-ones case is reserved for addressing the local bus, this leaves only 511 available unique bus identifiers. This is an artifact of the IEEE 1394–1995 standard.

The PHY-configuration packet can perform the following functions:

- Set the gap-count field of all nodes on the bus to a new value. The gap-count, if set intelligently, can optimize bus performance.
- Force a particular node to be the bus root after the next bus reset.

It is not valid to transmit a PHY-configuration packet with both the R bit and T bit set to zero. This would cause the packet to be interpreted as an extended PHY packet.

Table 4–9. PHY-Configuration Functions

FIELD NAME	DESCRIPTION
root_ID	The root_ID field is the physical_ID of the node to have its force_root bit set (only meaningful when R is set).
R	When R is set, the force-root bit of the node identified in root_ID is set and the force_root bit of all other nodes are cleared. When R is cleared, root_ID is ignored.
T	When T is set, the gap count field of all the nodes is set to the value in the gap_cnt field.
gap_cnt	The gap_cnt field contains the new value for gap count for all nodes. This value goes into effect immediately upon receipt and remains valid after the next bus reset. After the second reset, gap_cnt is set to 63h unless a new PHY-configuration packet is received.

4.8 Link-On Transmit

The transmit format of the link-on packet is shown in Figure 4–22 and described in Table 4–10. The link-on packet contains three quadlets, which are loaded into the ATF. The first quadlet is the tCode for an unformatted packet. This is written into ATF_First at address 80h and has a value of 0000_00E0h. The second quadlet consists of actual data. This is written into the ATF_Continue at address 84h and has a value of the first quadlet of the link-on packet. The third quadlet is the logical inverse of the second quadlet and it written into the ATF_Continue&Update at address 8Ch and has a value of the second quadlet of the link-on packet.

There is a possibility of a false header error on receipt of a link-on packet. If the first 16 bits of a link-on packet happen to match the destination identifier of a node (bus number and node number), the TSB12LV01B on that node issues a header error since the node misinterprets the link-on packet as a data packet addressed to the node. The suggested solution to this potential problem is to assign bus numbers that all have the most significant bit set to 1. Since the all-ones case is reserved for addressing the local bus, this leaves only 511 available unique bus identifiers. This is an artifact of the IEEE 1394-1995 standard.

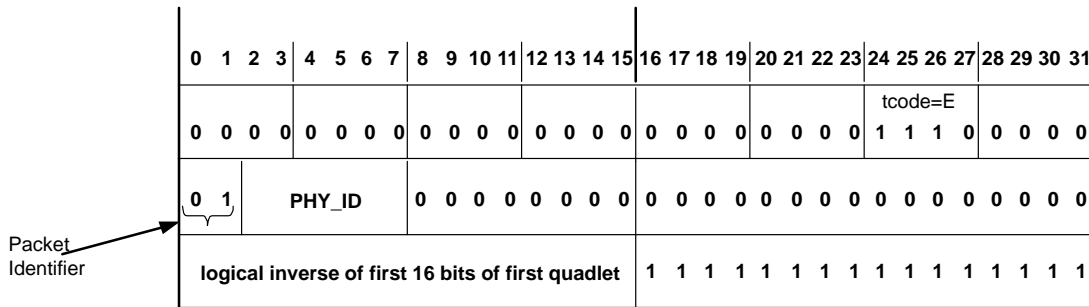

Figure 4–22. Link-On Packet Format

Table 4–10. Link-On Packet Functions

FIELD NAME	DESCRIPTION
PHY_ID	This field is the physical_ID of the node this packet is addressed to.

4.9 Receive Self-ID

The format of the receive self-ID packet is shown in Figure 4–23 and described in Table 4–11. The first quadlet is the packet token with the special code of Eh. The quadlets that follow are a concatenation of all received self-ID packets. See paragraph 4.3.4.1 of the IEEE 1394-1995 standard for additional information about self-ID packets.

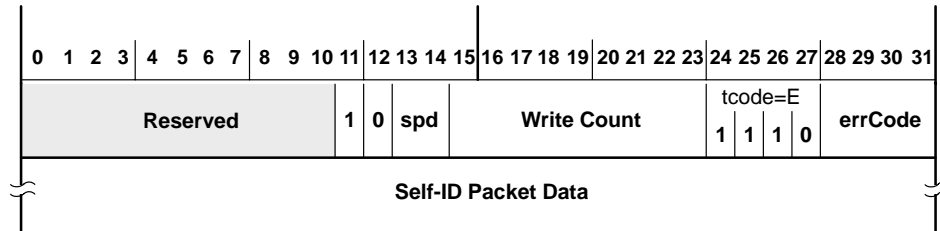

- NOTES: A. Bit 11 (PacCom) = 1
 B. Speed should be S100 (spd=00).

Figure 4–23. Receive Self-ID Packet Format(RxSID bit = 1)

Table 4–11. Received Self-ID Packet Functions

FIELD NAME	DESCRIPTION
spd	The spd field indicates the speed at which the current packet is to be sent (00 = 100 Mbits/s, 01 = 200 Mbits/s, and 10 = 400 Mbits/s, and 11 is undefined).
WriteCount	WriteCount indicates the number of data quadlets in the packet.
errCode	The errCode field indicates whether the current packet has been received correctly. The possibilities are complete, DataErr, or CRCErr, and have the same encoding as the corresponding acknowledge codes (See Table 6–13 of the IEEE 1394-1995 standard).
Self-ID packet data	This field contains a concatenation of all the self-ID packets received (see self-ID packet descriptions below)

The cable PHY sends one to three self-ID packets at the base rate (100 Mbits/s) during the self-ID phase of arbitration or in response to a ping packet. The number of self-ID packets sent depends on the number of PHY ports. Figures 4–24, 4–25, and 4–26 show the format of the cable PHY self-ID packets. Table 4–12 describes the details of these packets.

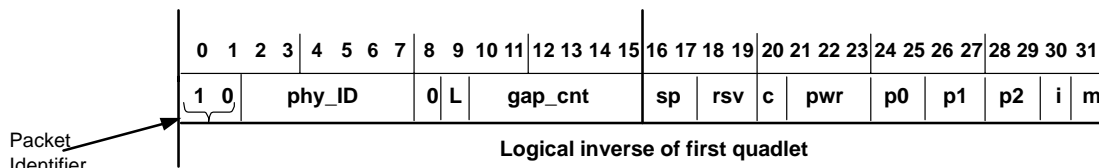

Figure 4–24. PHY Self-ID Packet #0 Format

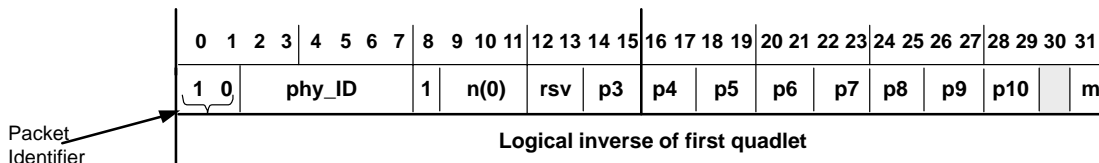

Figure 4–25. PHY Self-ID Packet #1 Format

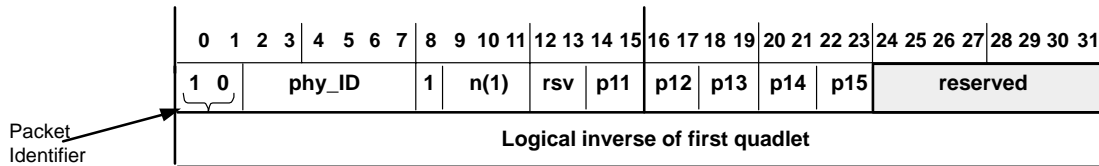

Figure 4–26. PHY Self-ID Packet #2 Format

Table 4–12. PHY Self-ID Packet Fields

FIELD NAME	DESCRIPTION
phy_ID	The phy_ID field contains the physical identification of the node transmitting the self-ID packet.
L	If set, this node has an active link and transaction layers.
gap_cnt	The gap_cnt field contains the current value for the current node PHY_CONFIGURATION.gap_count field.
sp	The sp field contains the PHY speed capability. The code is: 00 98.304 Mbits/s 01 98.304 Mbits/s and 196.608 Mbits/s 10 98.304 Mbits/s 196.608 Mbits/s, and 393.216 Mbits/s 11 Extended speed capabilities reported in PHY register 3
c	If set and the link_active flag is set, this node is contender for the bus or isochronous resource manager as described in clause 8.4.2 of IEEE Std 1394-1995.
pwr	Power consumption and source characteristics: 000 Node does not need power and does not repeat power. 001 Node is self-powered and provides a minimum of 15 W to the bus. 010 Node is self-powered and provides a minimum of 30 W to the bus. 011 Node is self-powered and provides a minimum of 45 W to the bus. 100 Node may be powered from the bus and is using up to 3 W. No additional power is needed to enable the link [†] . 101 Reserved for future standardization 110 Node is powered from the bus and is using up to 3 W. An additional 3 W is needed to enable the link [†] . 111 Node is powered from the bus and is using up to 3 W. An additional 7 W is needed to enable the link [†] .
p0 – p15	The p0 – p15 field indicates the port connection status. The code is: 00 Not present on the current PHY 01 Not connected to any other PHY 10 Connected to the parent node 11 Connected to the child node
i	If set, this node initiated the current bus reset (i.e., it started sending a bus_reset signal before it received one). [‡]
m	If set, another self-ID packet for this node will immediately follow (i.e., if this bit is set and the next self-ID packet received has a different phy_ID, the a self-ID packet was lost).
n	Extended self-ID packet sequence number.
rsv	Reserved and set to all zeros.

[†] The link is enabled by the link-on PHY packet described in clause 7.5.2 of the IEEE 1394.a spec.; this packet may also enable application layers.

[‡] There is no guarantee that exactly one node will have this bit set. More than one node may request a bus reset at the same time.

4.10 Received PHY Configuration and Link-On Packet

The format of the received PHY-configuration and link-on packet is similar to the received self-ID packet. In this case, the value of the errCode is 0000. Only the first quadlet of each packet is stored in the GRF. If the received second quadlet of each packet is not the inverse of the first one, the packet is ignored. See paragraph 4.3.4.2 of the IEEE 1394-1995 standard for additional information on link-on packets, and paragraph 4.3.4.3 for additional information on PHY-configuration packets.

5 Electrical Characteristics

5.1 Absolute Maximum Ratings Over Operating Free-Air Temperature Range (Unless Otherwise Noted)[†]

Supply voltage range, V_{CC}	-0.5 V to 3.6 V
Supply voltage range, V_{CC5V}	-0.5 V to 5.5 V
Input voltage range, V_I (standard TTL/LVCMOS)	-0.5 V to $V_{CC} + 0.5$ V
Input voltage range, V_I (5-V standard TTL/LVCMOS)	-0.5 V to $V_{CC} + 0.5$ V
Output voltage range, (standard TTL/LVCMOS) V_O	-0.5 V to $V_{CC} + 0.5$ V
Output voltage range, (5-V standard TTL/LVCMOS) V_O	-0.5 V to $V_{CC} + 0.5$ V
Input clamp current, I_{IK} (TTL/LVCMOS) ($V_I < 0$ or $V_I > V_{CC}$) (see Note 1)	± 20 mA
Output clamp current, I_{OK} (TTL/LVCMOS) ($V_O < 0$ or $V_O > V_{CC}$) (see Note 2)	± 20 mA
Continuous total power dissipation	See Maximum Dissipation Rating Table
Operating free-air temperature range, T_A	-40°C to 85°C
Storage temperature range, T_{stg}	-65°C to 150°C

[†] Stresses beyond those listed under “absolute maximum ratings” may cause permanent damage to the device. These are stress ratings only, and functional operation of the device at these or any other conditions beyond those indicated under “recommended operating conditions” is not implied. Exposure to absolute-maximum-rated conditions for extended periods may affect device reliability.

NOTES: 1. This applies to external input and bidirectional buffers. For 5-V tolerant terminals, use $V_I > V_{CC5V}$.
 2. This applies to external output and bidirectional buffers. For 5-V tolerant terminals, use $V_O > V_{CC5V}$.

MAXIMUM DISSIPATION RATING TABLE

PACKAGE	$T_A \leq 25^\circ\text{C}$	DERATING FACTOR ABOVE $T_A = 25^\circ\text{C}$	$T_A = 70^\circ\text{C}$	$T_A = 85^\circ\text{C}$
	POWER RATING		POWER RATING	POWER RATING
PZT	1500 mW	16.9 mW/°C	739.5 mW	486 mW

PACKAGE THERMAL RESISTANCE (R_θ) CHARACTERISTICS[†]

PARAMETER	TEST CONDITIONS	PZT PACKAGE			UNIT
		MIN	NOM	MAX	
$R_{\theta JA}$ Junction-to-ambient thermal resistance	Board mounted, No air flow		59		°C/W
$R_{\theta JC}$ Junction-to-case thermal resistance			13		°C/W
T_J Junction temperature				115	°C

[†] Thermal resistance characteristics vary depending on die and leadframe pad size as well as mold compound. These values represent typical die and pad sizes for the respective packages. The R value decreases as the die or pad sizes increases. Thermal values represent PWB bands with minimal amounts of metal.

5.2 Recommended Operating Conditions

		MIN	NOM	MAX	UNIT
Supply voltage, V_{CC}		3	3.3	3.6	V
Supply voltage, V_{CC5V}	5-V tolerant	3	5	5.5	V
	Non 5-V tolerant	3	3.3	3.6	V
High-level input voltage, V_{IH}		2			V
Low-level input voltage, V_{IL}		0.8			
Transition time, (t_t) (10% to 90%)		0		6	ns
Operating free-air temperature, T_A		-40	25	85	°C
Virtual junction temperature, T_J^\ddagger		0	25	115	°C

† This applies to external output buffers.

‡ The junction temperatures listed reflect simulation conditions. The absolute maximum junction temperature is 150°C. The customer is responsible for verifying the junction temperature.

5.3 Electrical Characteristics Over Recommended Ranges of Supply Voltage and Operating Free-Air Temperature (Unless Otherwise Noted)

PARAMETER		TEST CONDITIONS		MIN	TYP	MAX	UNIT	
V_{OH}	High-level output voltage	$I_{OH} = -8 \text{ mA}^\dagger$		$V_{CC} - 0.6$			V	
		$I_{OH} = -4 \text{ mA}^\ddagger$		$V_{CC} - 0.6$				
V_{OL}	Low-level output voltage	$I_{OL} = 8 \text{ mA}^\dagger$		0.5			V	
		$I_{OL} = 4 \text{ mA}^\ddagger$		0.5				
I_{IL}	Low-level input current $§$	$V_I = \text{GND}$	TTL/LVCMOS	-1			μA	
			5-V tolerant	-20				
			D0 – D7, CTL0, CTL1	-20				
I_{IH}	High-level input current	$V_I = V_{CC}$	TTL/LVCMOS	1			μA	
			$V_I = V_{CC5V}$	5-V tolerant	20			
				D0 – D7, CTL0, CTL1	20			
I_{OZ}	High-impedance-state output current \P	$V_O = V_{CC}$ or GND		± 20			μA	
$I_{CC(Q)}$	Static supply current	$I_O = 0$		88			μA	
$I_{CC(\text{Dynamic})}$	Dynamic supply current			120			mA	

† This test condition is for terminals D0 – D7, CTL0, CTL1, LREQ, and POWERON

‡ This test condition is for terminals DATA0 – DATA31, CA, INT, CYCLEOUT, GRFEMP, CYDNE, and CYST.

§ This specification only applies when pullup and pulldown terminator is turned off.

\P Three-state output must be in high-impedance mode.

5.4 Host-Interface Timing Requirements, $T_A = 25^\circ\text{C}$ (see Note 3)

PARAMETER	MIN	MAX	UNIT
t_{c1} Cycle time, BCLK (see Figure 6–1)	20	111	ns
$t_{w1(H)}$ Pulse duration, BCLK high (see Figure 6–1)	8.6		ns
$t_{w1(L)}$ Pulse duration, BCLK low (see Figure 6–1)	8.6		ns
t_{su1} Setup time, DATA0 – DATA31 valid before BCLK \uparrow (see Figures 6–2, 6–4, 6–6)	4		ns
t_{h1} Hold time, DATA0 – DATA31 valid after BCLK \uparrow (see Figures 6–2, 6–4, 6–6)	2		ns
t_{su2} Setup time, ADDR0 – ADDR7 valid before BCLK \uparrow (see Figures 6–2, 6–3, 6–4)	8		ns
t_{h2} Hold time, ADDR0 – ADDR7 valid after BCLK \uparrow (see Figures 6–2, 6–3, 6–4)	2		ns
t_{su3} Setup time, \overline{CS} low before BCLK \uparrow (see Figures 6–2, 6–3, 6–4)	8		ns
t_{h3} Hold time, \overline{CS} low after BCLK \uparrow (see Figures 6–2, 6–3, 6–4)	2		ns
t_{su4} Setup time, \overline{WR} valid before BCLK \uparrow (see Figures 6–2, 6–3, 6–4)	8		ns
t_{h4} Hold time, \overline{WR} valid after BCLK \uparrow (see Figures 6–2, 6–3, 6–4)	2		ns

NOTE 3: These parameters are not production tested.

5.5 Host-Interface Switching Characteristics Over Recommended Operating Free-Air Temperature Range, $C_L = 45$ pF (Unless Otherwise Noted)

PARAMETER	MIN	MAX	UNIT
t_{d1} Delay time, BCLK \uparrow to $\overline{CA}\downarrow$ (see Figures 6–2, 6–3, 6–5, 6–6, 6–7)	2.5	8	ns
t_{d2} Delay time, BCLK \uparrow to $\overline{CA}\uparrow$ (see Figures 6–2, 6–3, 6–5, 6–6, 6–7)	2.5	8	ns
t_{d3} Delay time, BCLK \uparrow to DATA0 – DATA31 valid (see Figures 6–3, 6–5, 6–7, and Note 3)	2.5	10	ns
t_{d4} Delay time, BCLK \uparrow to DATA0 – DATA31 invalid (see Figures 6–3, 6–5, 6–7, and Note 3)	2.5	10	ns

NOTE 3: These parameters are not production tested.

5.6 Cable PHY-Layer-Interface Timing Requirements Over Recommended Operating Free-Air Temperature Range (see Note 3)

PARAMETER	MIN	MAX	UNIT
t_{c2} Cycle time, SCLK (see Figure 6–8)	20.347	20.343	ns
$t_{w2(H)}$ Pulse duration, SCLK high (see Figure 6–8)	9		ns
$t_{w2(L)}$ Pulse duration, SCLK low (see Figure 6–8)	9		ns
t_{su5} Setup time, D0 – D7 valid before SCLK \uparrow (see Figure 6–10)	4		ns
t_{h5} Hold time, D0 – D7 valid after SCLK \uparrow (see Figure 6–10)	0		ns
t_{su6} Setup time, CTL0 – CTL1 valid before SCLK \uparrow (see Figure 6–10)	4		ns
t_{h6} Hold time, CTL0 – CTL1 valid after SCLK \uparrow (see Figure 6–10)	0		ns

NOTE 3: These parameters are not production tested.

5.7 Cable PHY-Layer-Interface Switching Characteristics Over Recommended Operating Free-Air Temperature Range, $C_L = 45$ pF (Unless Otherwise Noted) (see Note 3)

PARAMETER	MIN	MAX	UNIT
t_{d5} Delay time, SCLK \uparrow to D0 – D7 valid (see Figure 6–9)	1	11	ns
t_{d6} Delay time, SCLK \uparrow to D0 – D7 invalid (see Figure 6–9)	1	11	ns
t_{d7} Delay time, SCLK \uparrow to D0 – D7 invalid (see Figure 6–9)	1	11	ns
t_{d8} Delay time, SCLK \uparrow to CTL0 – CTL1 valid (see Figure 6–9)	1	11	ns
t_{d9} Delay time, SCLK \uparrow to CTL0 – CTL1 invalid (see Figure 6–9)	1	11	ns
t_{d10} Delay time, SCLK \uparrow to CTL0 – CTL1 invalid (see Figure 6–9)	1	11	ns
t_{d11} Delay time, SCLK \uparrow to LREQ \downarrow (see Figure 6–11)	1	11	ns

NOTE 3: These parameters are not production tested.

5.8 Miscellaneous Timing Requirements Over Recommended Operating Free-Air Temperature Range (see Figure 6–13 and Note 3)

PARAMETER	MIN	MAX	UNIT
t_{c3} Cycle time, CYCLEIN (see Figure 6–13)	124.99	125.01	μ s
$t_{w3(H)}$ Pulse duration, CYCLEIN high (see Figure 6–13)	0.08	120	μ s
$t_{w3(L)}$ Pulse duration, CYCLEIN low (see Figure 6–13)	4		μ s

NOTE 3: These parameters are not production tested.

5.9 Miscellaneous Signal Switching Characteristics Over Recommended Operating Free-Air Temperature Range (see Note 3)

PARAMETER	MIN	MAX	UNIT
t_{d12} Delay time, SCLK \uparrow to $\overline{INT}\downarrow$ (see Figure 6–12)	4	18	ns
t_{d13} Delay time, SCLK \uparrow to $\overline{INT}\uparrow$ (see Figure 6–12)	4	18	ns
t_{d14} Delay time, SCLK \uparrow to CYCLEOUT \uparrow (see Figure 6–14)	4	16	ns
t_{d15} Delay time, SCLK \uparrow to CYCLEOUT \downarrow (see Figure 6–14)	4	16	ns

NOTE 3: These parameters are not production tested.

6 Parameter Measurement Information

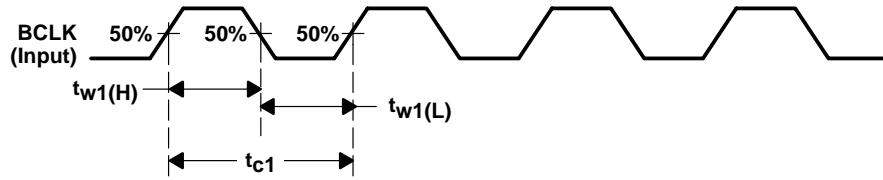
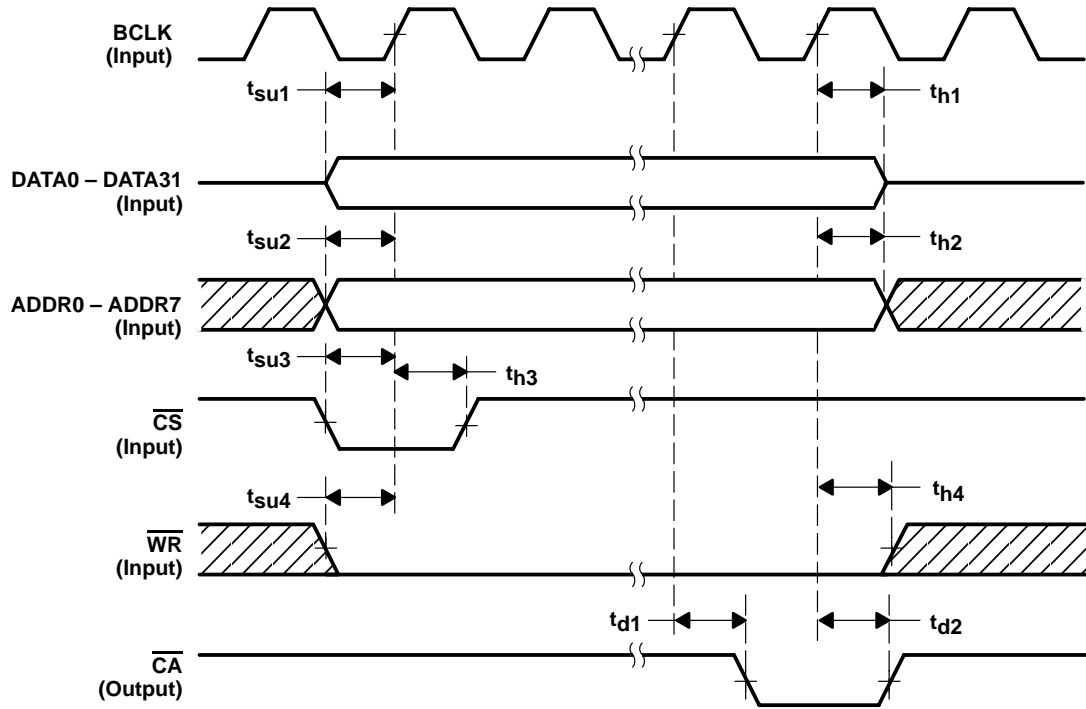
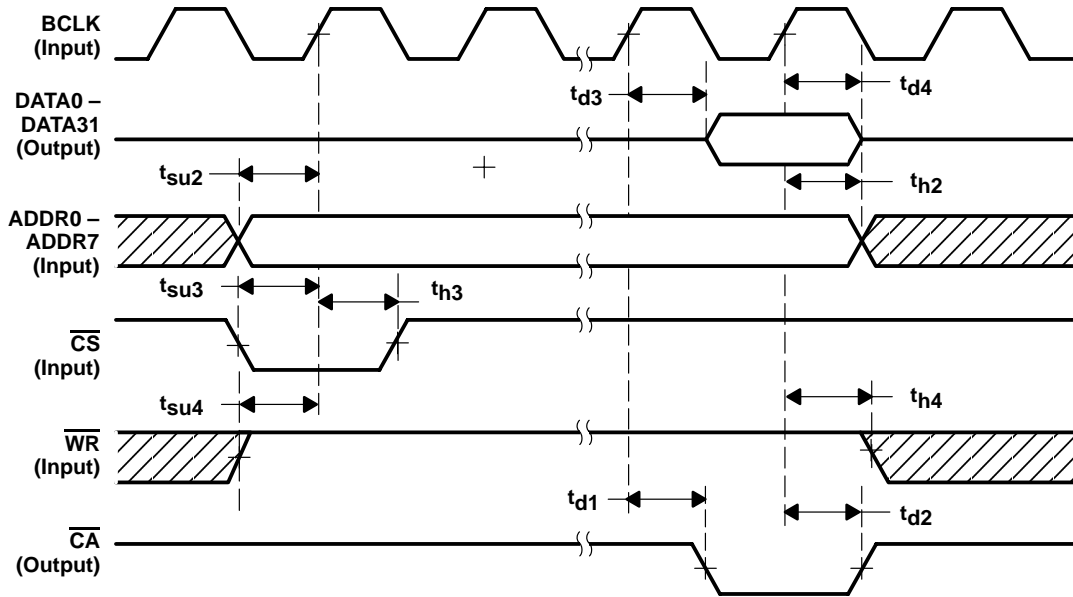

Figure 6-1. BCLK Waveform



NOTE A. Following a \overline{CS} assertion, there may be a maximum of 9 rising edges of BCLK before a \overline{CA} is returned. \overline{CA} must be returned before another \overline{CS} may be asserted.

Figure 6-2. Host-Interface Write-Cycle Waveforms (Address: 00h - 2Ch)



NOTE A. Following a \overline{CS} assertion, there may be a maximum of 9 rising edges of BCLK before a \overline{CA} is returned. \overline{CA} must be returned before another \overline{CS} may be asserted.

Figure 6-3. Host-Interface Read-Cycle Waveforms (Address: 00h – 2Ch)

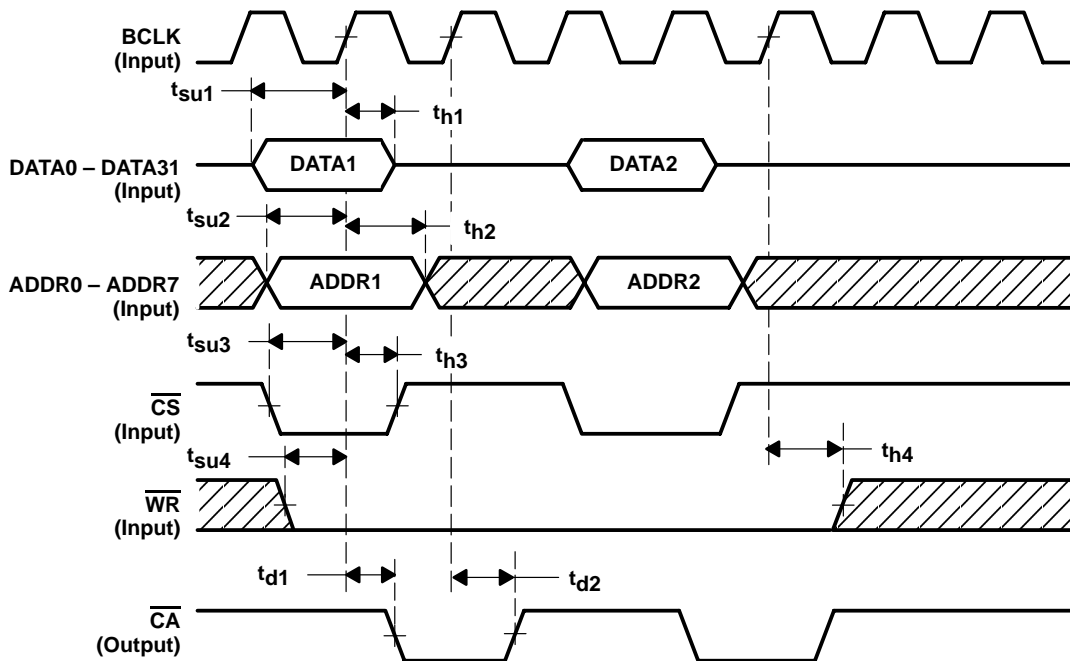

NOTE A. There must be a minimum of 3 rising edges of BCLK between assertions of \overline{CS} .

Figure 6-4. Host-Interface Quick Write-Cycle Waveforms (Address $\geq 30h$)

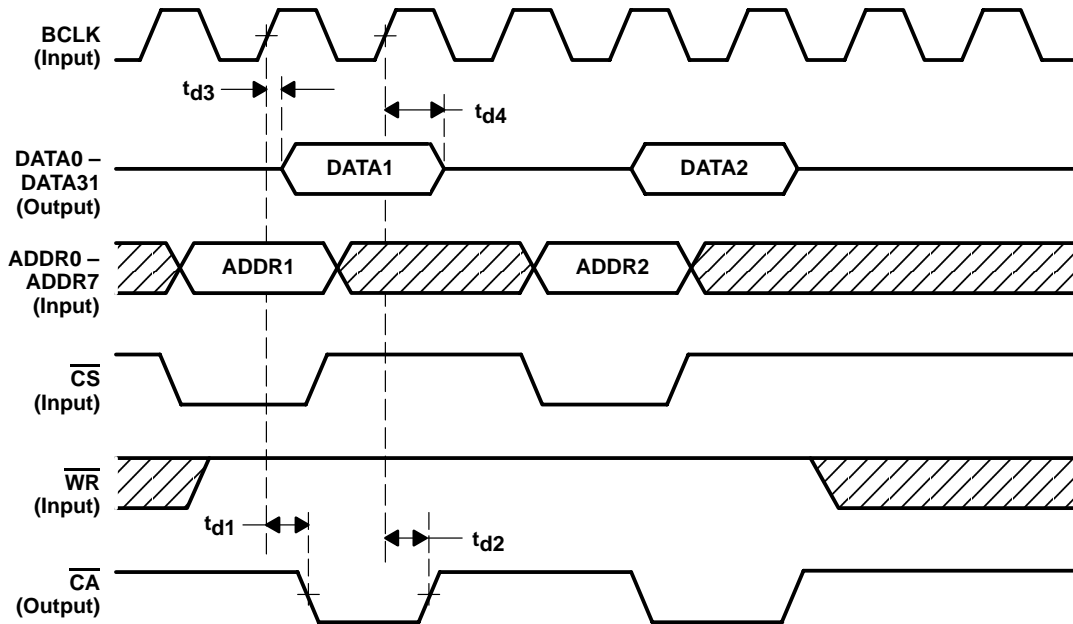

NOTE A. There must be a minimum of 3 rising edges of BCLK between assertions of \overline{CS} .

Figure 6-5. Host-Interface Quick Read-Cycle Waveforms (ADDRESS $\geq 30h$)

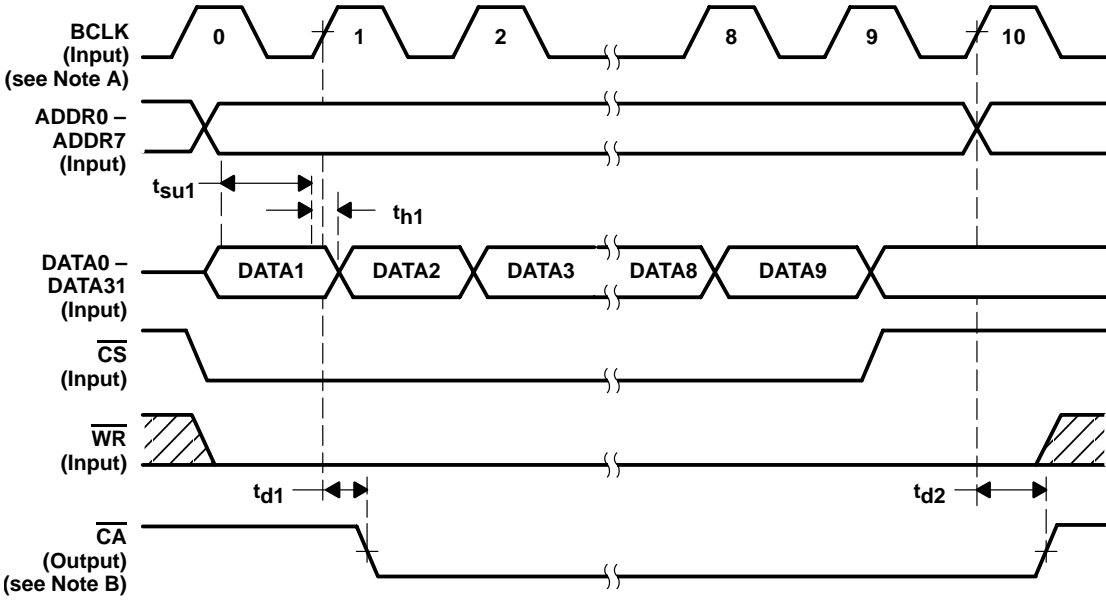

NOTES: A. At the n th BCLK rising edge, $DATA_n$ is written into the FIFO.
 B. \overline{CA} is one cycle delay from respective \overline{CS} .

Figure 6-6. Burst Write Waveforms

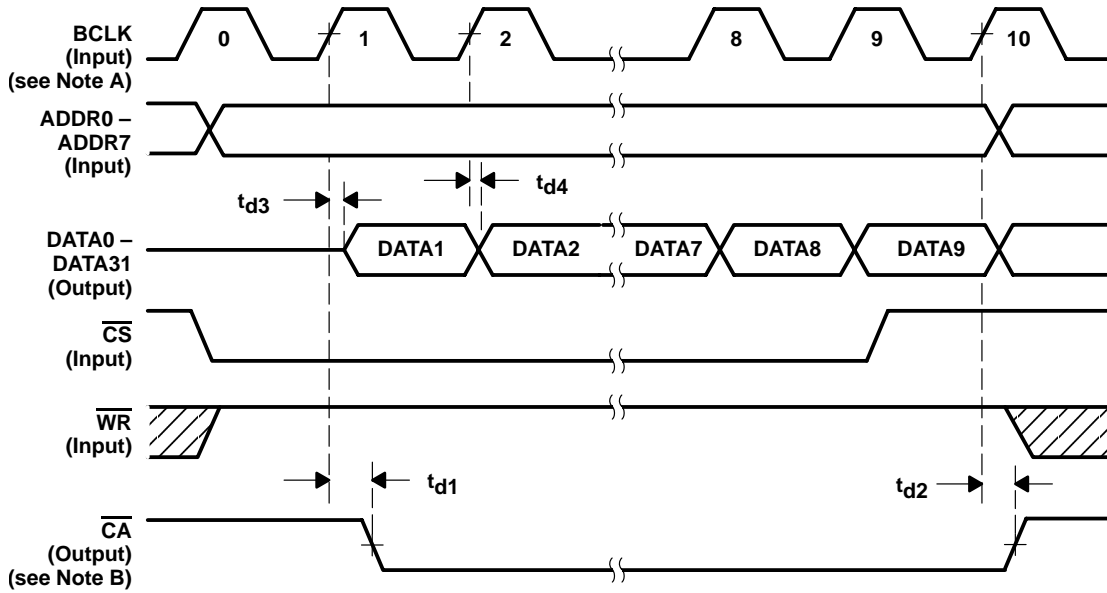

- NOTES: A. At the (nth+1) BCLK rising edge, host bus should latch DATA_n.
 B. CA is one cycle delay from respective CS.
 C. These waveforms only apply to address C0h.

Figure 6-7. Burst Read Waveforms

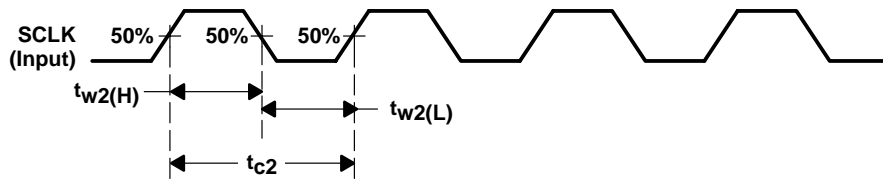

Figure 6-8. SCLK Waveform

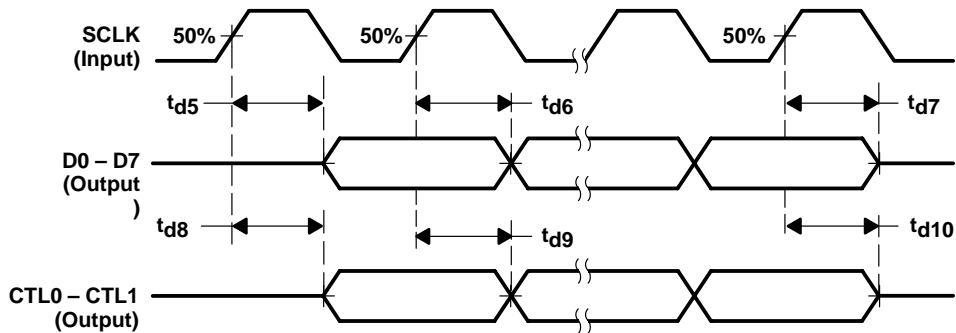

Figure 6-9. TSB12LV01B-to-PHY-Layer Interface Transfer Waveforms

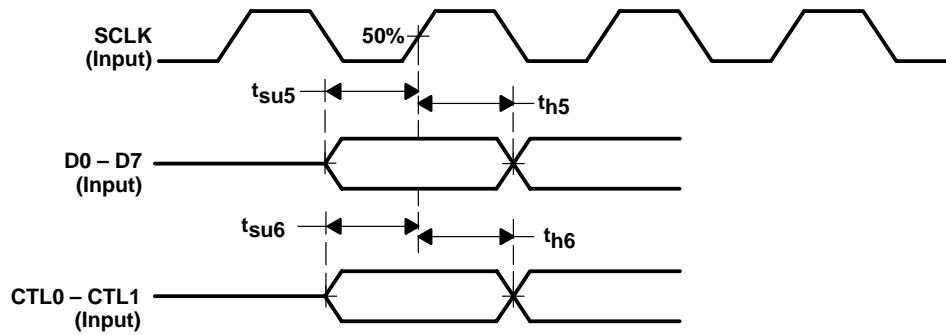

Figure 6-10. PHY Layer Interface-to-TSB12LV01B Transfer Waveforms

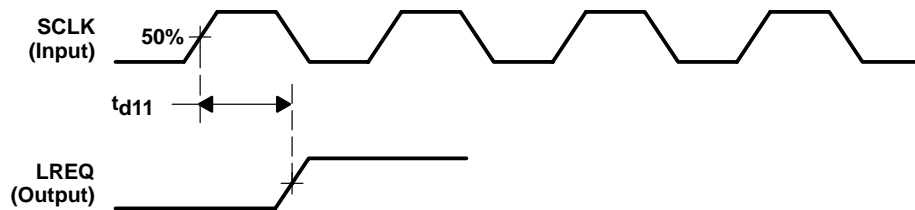

Figure 6-11. TSB12LV01B Link-Request-to-PHY-Layer Interface Waveforms

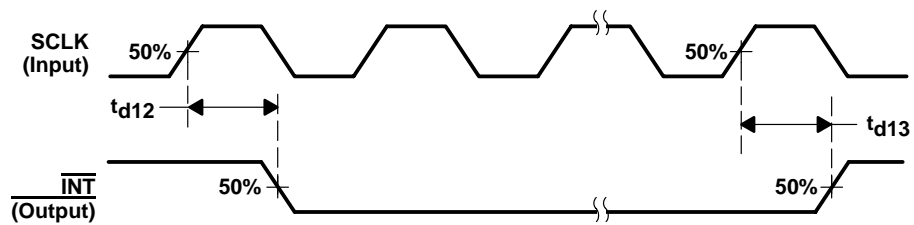

Figure 6-12. Interrupt Waveform

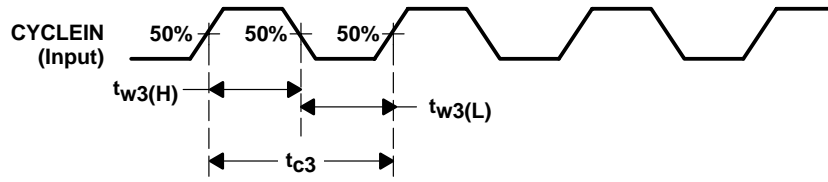

Figure 6-13. CYCLEIN Waveform

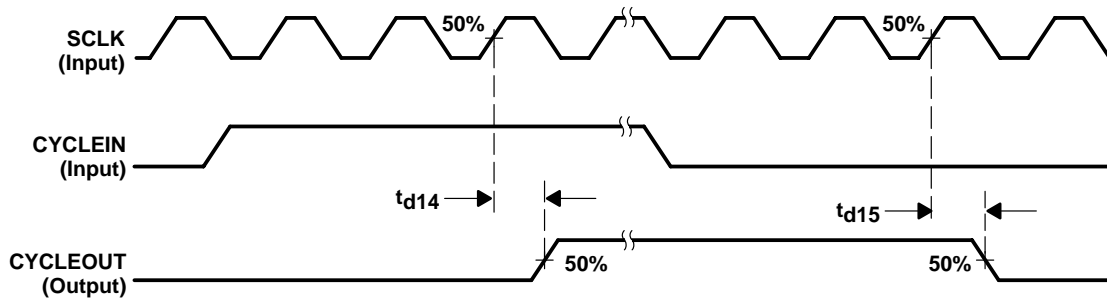

Figure 6-14. CYCLEIN and CYCLEOUT Waveforms

7 TSB12LV01B to 1394 PHY Interface Specification

This chapter provides an overview of the digital interface between a TSB12LV01B and a physical layer device (PHY). The information that follows can be used as a guide through the process of connecting the TSB12LV01B to a 1394 PHY. The part numbers referenced, the TSB41LV03A and the TSB12LV01B, represent the Texas Instruments implementation of the PHY (TSB41LV03A) and link (TSB12LV01B) layers of the IEEE 1394-1995 and P1394a standards.

The specific details of how the TSB41LV03A device operates are not discussed in this document. Only those parts that relate to the TSB12LV01B PHY interface are mentioned.

7.1 Principles of Operation

The TSB12LV01B is designed to operate with a Texas Instruments physical-layer device. The following paragraphs describe the operation of the PHY-LLC interface assuming a TSB41LV03A PHY. The TSB41LV03A is an IEEE 1394a three port cable transceiver/arbiter PHY capable of 400 Mb/s speeds.

The interface to the PHY consists of the SCLK, CTL0–CTL1, D0–D7, LREQ, and POWERON terminals on the TSB12LV01B, as shown in Figure 7–1.

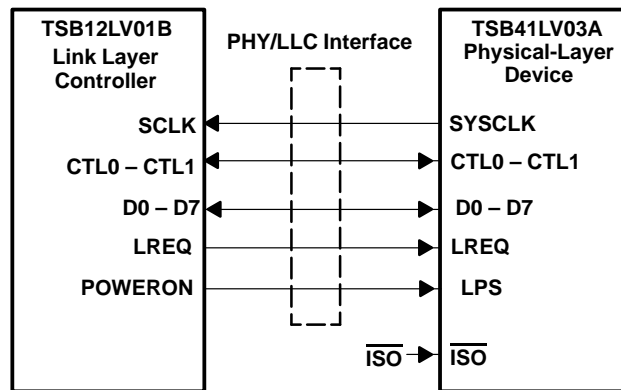

Figure 7–1. PHY-LLC Interface

The SYCLK from the PHY terminal provides a 49.152-MHz interface clock. All control and data signals are synchronized to, and sampled on, the rising edge of SYCLK.

The CTL0 and CTL1 terminals form a bidirectional control bus, which controls the flow of information and data between the TSB41LV03A and TSB12LV01B.

The D0–D7 terminals form a bidirectional data bus, which is used to transfer status information, control information, or packet data between the devices. The TSB41LV03A supports S100, S200, and S400 data transfers over the D0–D7 data bus. In S100 operation only the D0 and D1 terminals are used; in S200 operation only the D0–D3 terminals are used; and in S400 operation all D0–D7 terminals are used for data transfer. When the TSB41LV03A is in control of the D0–D7 bus, unused Dn terminals are driven low during S100 and S200 operations. When the TSB12LV01B is in control of the D0–D7 bus, unused Dn terminals are ignored by the TSB41LV03A.

The LREQ terminal is controlled by the TSB12LV01B to send serial service requests to the PHY in order to request access to the serial-bus for packet transmission, read or write PHY registers, or control arbitration acceleration.

The POWERON and LPS terminals are used for power management of the PHY and TSB12LV01B. The POWERON terminal indicates the power status of the TSB12LV01B, and may be used to reset the PHY-LLC interface or to disable SYCLK.

The $\overline{\text{ISO}}$ terminal is used to enable the output differentiation logic on the CTL0-CTL1 and D0-D7 terminals. Output differentiation is required when an Annex J type isolation barrier is implemented between the PHY and TSB12LV01B.

The TSB41LV03A normally controls the CTL0-CTL1 and D0-D7 bidirectional buses. The TSB12LV01B is allowed to drive these buses only after the TSB12LV01B has been granted permission to do so by the PHY. There are four operations that may occur on the PHY-LLC interface: link service request, status transfer, data transmit, and data receive. The TSB12LV01B issues a service request to read or write a PHY register, to request the PHY to gain control of the serial-bus in order to transmit a packet, or to control arbitration acceleration.

The PHY may initiate a status transfer either autonomously or in response to a register read request from the TSB12LV01B. The PHY initiates a receive operation whenever a packet is received from the serial-bus. The PHY initiates a transmit operation after winning control of the serial-bus following a bus-request by the TSB12LV01B. The transmit operation is initiated when the PHY grants control of the interface to the TSB12LV01B.

The encoding of the CTL0-CTL1 bus is shown in Table 7-1 and Table 7-2.

Table 7-1. CTL Encoding When the PHY Has Control of the Bus

CTL0	CTL1	NAME	DESCRIPTION OF ACTIVITY
0	0	Idle	No activity (this is the default mode).
0	1	Status	Status information is being sent from the PHY layer to the TSB12LV01B.
1	0	Receive	An incoming packet is being sent from the PHY layer to the TSB12LV01B.
1	1	Grant	The TSB12LV01B is given control of the bus to send an outgoing packet.

Table 7-2. CTL Encoding When the TSB12LV01B Has Control of the Bus

CTL0	CTL1	NAME	DESCRIPTION OF ACTIVITY
0	0	Idle	The TSB12LV01B releases the bus (transmission has been completed).
0	1	Hold	The TSB12LV01B is holding the bus while data is being prepared for transmission, or indicating that another packet is to be transmitted (concatenated) without arbitrating.
1	0	Transmit	An outgoing packet is being sent from the TSB12LV01B to the PHY.
1	1	Reserved	None

7.2 TSB12LV01B Service Request

To request access to the bus, to read or write a PHY register, or to control arbitration acceleration, the TSB12LV01B sends a serial bit stream on the LREQ terminal as shown in Figure 7-2.



Figure 7-2. LREQ Request Stream

The length of the stream will vary depending on the type of request as shown in Table 7-3.

Table 7-3. Request Stream Bit Length

NAME	NUMBER of BITS
Bus request	7 or 8
Read register request	9
Write register request	17
Acceleration control request	6

Regardless of the type of request, a start-bit of 1 is required at the beginning of the stream, and a stop-bit of 0 is required at the end of the stream. The second through fourth bits of the request stream indicate the type of the request. In the descriptions below, bit 0 is the most significant and is transmitted first in the request bit stream. The LREQ terminal is normally low.

Encoding for the request type is shown in Table 7–4.

Table 7–4. Request Type Encoding

LR1–LR3	NAME	DESCRIPTION
000	ImmReq	Immediate bus request. Upon detection of idle, the PHY takes control of the bus immediately without arbitration.
001	IsoReq	Isochronous bus request. Upon detection of idle, the PHY arbitrates for the bus without waiting for a subaction gap.
010	PriReq	Priority bus request. The PHY arbitrates for the bus after a subaction gap, ignores the fair protocol.
011	FairReq	Fair bus request. The PHY arbitrates for the bus after a subaction gap, follows the fair protocol.
100	RdReg	The PHY returns the specified register contents through a status transfer.
101	WrReg	Write to the specified register
110	AccelCtl	Enable or disable asynchronous arbitration acceleration.
111	Reserved	Reserved

For a bus request the length of the LREQ bit stream is 7 or 8 bits as shown in Table 7–5.

Table 7–5. Bus Request

BIT(s)	NAME	DESCRIPTION
0	Start bit	Indicates the beginning of the transfer (always 1)
1–3	Request type	Indicates the type of bus request. See Table 7–4.
4–6	Request speed	Indicates the speed at which the PHY will send the data for this request. See Table 7–6 for the encoding of this field.
7	Stop bit	Indicates the end of the transfer (always 0). If bit 6 is 0, this bit may be omitted.

The 3-bit request speed field used in bus requests is shown in Table 7–6.

Table 7–6. Bus Request Speed Encoding

LR4–LR6	DATA RATE
000	S100
010	S200
100	S400
All Others	Invalid

NOTE:

The TSB41LV03A will accept a bus request with an invalid speed code and process the bus request normally. However, during packet transmission for such a request, the TSB41LV03A will ignore any data presented by the TSB12LV01B and will transmit a null packet.

For a read register request the length of the LREQ bit stream is 9 bits as shown in Table 7–7.

Table 7–7. Read Register Request

BIT(S)	NAME	DESCRIPTION
0	Start bit	Indicates the beginning of the transfer (always 1)
1–3	Request type	A <i>100</i> indicates this is a read register request.
4–7	Address	Identifies the address of the PHY register to be read
8	Stop bit	Indicates the end of the transfer (always 0)

For a write register request the length of the LREQ bit stream is 17 bits as shown in Table 7–8.

Table 7–8. Write Register Request

BIT(S)	NAME	DESCRIPTION
0	Start bit	Indicates the beginning of the transfer (always 1)
1–3	Request type	A <i>101</i> indicates this is a write register request.
4–7	Address	Identifies the address of the PHY register to be written to
8–15	Data	Gives the data that is to be written to the specified register address
16	Stop bit	Indicates the end of the transfer (always 0)

For an acceleration control request the length of the LREQ bit stream is 6 bits as shown in Table 7–9.

Table 7–9. Acceleration Control Request

BIT(S)	NAME	DESCRIPTION
0	Start bit	Indicates the beginning of the transfer (always 1)
1–3	Request type	A <i>110</i> indicates this is an acceleration control request.
4	Control	Asynchronous period arbitration acceleration is enabled if 1, and disabled if 0
5	Stop bit	Indicates the end of the transfer (always 0)

For fair or priority access, the TSB12LV01B sends the bus request (FairReq or PriReq) at least one clock after the PHY-LLC interface becomes idle. If the CTL terminals are asserted to the receive state ('b10) by the PHY, then any pending fair or priority request is lost (cleared). Additionally, the PHY ignores any fair or priority requests if the receive state is asserted while the TSB12LV01B is sending the request. The TSB12LV01B may then reissue the request one clock after the next interface idle.

The cycle master node uses a priority bus request (PriReq) to send a cycle start message. After receiving or transmitting a cycle start message, the TSB12LV01B can issue an isochronous bus request (IsoReq). The PHY will clear an isochronous request only when the serial bus has been won.

To send an acknowledge packet, the TSB12LV01B must issue an immediate bus request (ImmReq) during the reception of the packet addressed to it. This is required in order to minimize the idle gap between the end of the received packet and the start of the transmitted acknowledge packet. As soon as the receive packet ends, the PHY immediately grants control of the bus to the TSB12LV01B. The TSB12LV01B sends an acknowledgment to the sender unless the header CRC of the received packet is corrupted. In this case, the TSB12LV01B does not transmit an acknowledgment, but instead cancels the transmit operation and releases the interface immediately; the TSB12LV01B must not use this grant to send another type of packet. After the interface is released the TSB12LV01B may proceed with another request.

The TSB12LV01B may make only one bus request at a time. Once the TSB12LV01B issues any request for bus access (ImmReq, IsoReq, FairReq, or PriReq), it cannot issue another bus request until the PHY indicates that the bus request was *lost* (bus arbitration lost and another packet received), or *won* (bus arbitration won and the TSB12LV01B granted control). The PHY ignores new bus requests while a previous bus request is pending. All bus requests are cleared upon a bus reset.

For write register requests, the PHY loads the specified data into the addressed register as soon as the request transfer is complete. For read register requests, the PHY returns the contents of the addressed register to the TSB12LV01B at the next opportunity through a status transfer. If a received packet interrupts the status transfer, then the PHY continues to attempt the transfer of the requested register until it is successful. A write or read register request may be made at any time, including while a bus request is pending. Once a read register request is made, the PHY ignores further read register requests until the register contents are successfully transferred to the TSB12LV01B. A bus reset does not clear a pending read register request.

The TSB41LV03A includes several arbitration acceleration enhancements, which allow the PHY to improve bus performance and throughput by reducing the number and length of inter-packet gaps. These enhancements include autonomous (fly-by) isochronous packet concatenation, autonomous fair and priority packet concatenation onto acknowledge packets, and accelerated fair and priority request arbitration following acknowledge packets. The enhancements are enabled when the EAA bit in PHY register 5 is set.

The arbitration acceleration enhancements may interfere with the ability of the cycle master node to transmit the cycle start message under certain circumstances. The acceleration control request is therefore provided to allow the TSB12LV01B to temporarily enable or disable the arbitration acceleration enhancements of the TSB41LV03A during the asynchronous period. The TSB12LV01B typically disables the enhancements when its internal cycle counter rolls over indicating that a cycle start message is imminent, and then re-enables the enhancements when it receives a cycle start message. The acceleration control request may be made at any time and is immediately serviced by the PHY. Additionally, a bus reset or isochronous bus request will cause the enhancements to be re-enabled, if the EAA bit is set.

7.3 Status Transfer

A status transfer is initiated by the PHY when there is status information to be transferred to the TSB12LV01B. The PHY waits until the interface is idle before starting the transfer. The transfer is initiated by the PHY asserting status ('b01) on the CTL terminals, along with the first two bits of status information on the D[0:1] terminals. The PHY maintains CTL = status for the duration of the status transfer. The PHY may prematurely end a status transfer by asserting something other than status on the CTL terminals. This occurs if a packet is received before the status transfer completes. The PHY continues to attempt to complete the transfer until all status information has been successfully transmitted. There is at least one idle cycle between consecutive status transfers.

The PHY normally sends just the first four bits of status to the TSB12LV01B. These bits are status flags that are needed by the TSB12LV01B state machines. The PHY sends an entire 16-bit status packet to the TSB12LV01B after a read register request, or when the PHY has pertinent information to send to the TSB12LV01B or transaction layers. The only defined condition where the PHY automatically sends a register to the TSB12LV01B is after self-ID, where the PHY sends the physical-ID register that contains the new node address. All status transfers are either 4 or 16 bits unless interrupted by a received packet. The status flags are considered to have been successfully transmitted to the TSB12LV01B immediately upon being sent, even if a received packet subsequently interrupts the status transfer. Register contents are considered to have been successfully transmitted only when all 8 bits of the register have been sent. A status transfer is retried after being interrupted only if any status flags remain to be sent, or if a register transfer has not yet completed.

The definitions of the bits in the status transfer are shown in Table 7–10 and the timing is shown in Figure 7–3.

Table 7–10. Status Bits

BIT(s)	NAME	DESCRIPTION
0	Arbitration reset gap	Indicates that the PHY has detected that the bus has been idle for an arbitration reset gap time (as defined in IEEE Std 1394-1995). This bit is used by the TSB12LV01B in the busy/retry state machine.
1	Subaction gap	Indicates that the PHY has detected that the bus has been idle for a subaction gap time (as defined in IEEE Std 1394-1995). This bit is used by the TSB12LV01B to detect the completion of an isochronous cycle.
2	Bus reset	Indicates that the PHY has entered the bus reset start state.
3	Interrupt	Indicates that a PHY interrupt event has occurred. An interrupt event may be a configuration time-out, cable-power voltage falling too low, a state time-out, or a port status change.
4–7	Address	This field holds the address of the PHY register whose contents are being transferred to the TSB12LV01B.
8–15	Data	This field holds the register contents.

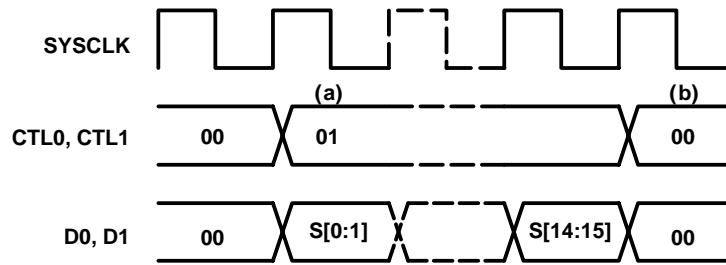

Figure 7–3. Status Transfer Timing

The sequence of events for a status transfer is as follows:

- Status transfer initiated. The PHY indicates a status transfer by asserting status on the CTL lines along with the status data on the D0 and D1 lines (only 2 bits of status are transferred per cycle). Normally (unless interrupted by a receive operation), a status transfer will be either 2 or 8 cycles long. A 2-cycle (4-bit) transfer occurs when only status information is to be sent. An 8-cycle (16-bit) transfer occurs when register data is to be sent in addition to any status information.
- Status transfer terminated. The PHY normally terminates a status transfer by asserting idle on the CTL lines. The PHY may also interrupt a status transfer at any cycle by asserting receive on the CTL lines to begin a receive operation. The PHY shall assert at least one cycle of idle between consecutive status transfers.

7.4 Receive Operation

Whenever the PHY detects the data-prefix state on the serial bus, it initiates a receive operation by asserting receive on the CTL terminals and a logic 1 on each of the D terminals (data-on indication). The PHY indicates the start of a packet by placing the speed code (encoded as shown in Table 7–11 on the D terminals, followed by the packet data. The PHY holds the CTL terminals in the receive state until the last symbol of the packet has been transferred. The PHY indicates the end of packet data by asserting idle on the CTL terminals. All received packets are transferred to the TSB12LV01B. Note that the speed code is part of the PHY-LLC protocol and is not included in the calculation of CRC or any other data protection mechanisms.

It is possible for the PHY to receive a null packet, which consists of the data-prefix state on the serial bus followed by the data-end state, without any packet data. A null packet is transmitted whenever the packet speed exceeds the capability of the receiving PHY, or whenever the TSB12LV01B immediately releases the bus without transmitting any data. In this case, the PHY will assert receive on the CTL terminals with the data-on indication (all 1's) on the D terminals, followed by idle on the CTL terminals, without any speed code or data being transferred. In all cases, the TSB41LV03B sends at least one data-on indication before sending the speed code or terminating the receive operation.

The TSB41LV03B also transfers its own self-ID packet, transmitted during the self-ID phase of bus initialization, to the TSB12LV01B. This packet is transferred to the TSB12LV01B just as any other received self-ID packet.

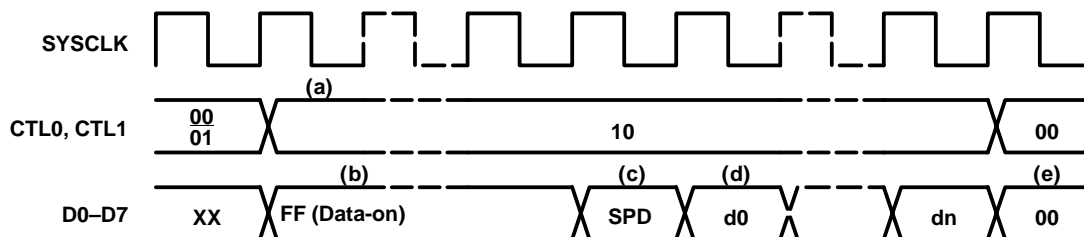

Figure 7-4. Normal Packet Reception Timing

The sequence of events for a normal packet reception is as follows:

- Receive operation initiated. The PHY indicates a receive operation by asserting receive on the CTL lines. Normally, the interface is Idle when receive is asserted. However, the receive operation may interrupt a status transfer operation that is in progress so that the CTL lines may change from status to receive without an intervening idle.
- Data-on indication. The PHY asserts the data-on indication code on the D lines for one or more cycles preceding the speed-code.
- Speed-code. The PHY indicates the speed of the received packet by asserting a speed-code on the D lines for one cycle immediately preceding the packet data. The link decodes the speed-code on the first receive cycle for which the D lines are not the data-on code. If the speed-code is invalid, or indicates a speed higher than that which the link is capable of handling, the link should ignore the subsequent data.
- Receive data. Following the data-on indication (if any) and the speed-code, the PHY asserts packet data on the D lines with receive on the CTL lines for the remainder of the receive operation.
- Receive operation terminated. The PHY terminates the receive operation by asserting idle on the CTL lines. The PHY asserts at least one cycle of idle following a receive operation.

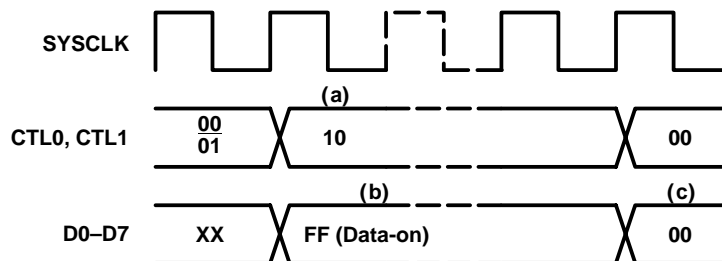

Figure 7-5. Null Packet Reception Timing

The sequence of events for a null packet reception is as follows:

- Receive operation initiated. The PHY indicates a receive operation by asserting receive on the CTL lines. Normally, the interface is idle when receive is asserted. However, the receive operation may interrupt a status transfer operation that is in progress so that the CTL lines may change from status to receive without an intervening idle.
- Data-on indication. The PHY asserts the data-on indication code on the D lines for one or more cycles.
- Receive operation terminated. The PHY terminates the receive operation by asserting idle on the CTL lines. The PHY shall assert at least one cycle of idle following a receive operation.

Table 7–11. Receive Speed Codes

D0 – D7	DATA RATE
00XXXXXX†	S100
0100XXXX†	S200
01010000	S400
1YYYYYYY‡	Data-on indication

†X = output as 0 by PHY, ignored by TSB12LV01B.

‡Y = output as 1 by PHY, ignored by TSB12LV01B.

7.5 Transmit Operation

When the TSB12LV01B issues a bus request through the LREQ terminal, the PHY arbitrates to gain control of the bus. If the PHY wins arbitration for the serial bus, the PHY-LLC interface bus is granted to the TSB12LV01B by asserting the grant state ('b11) on the CTL terminals for one SYCLK cycle, followed by idle for one clock cycle. The TSB12LV01B then takes control of the bus by asserting either idle ('b00), hold ('b01) or transmit ('b10) on the CTL terminals. Unless the TSB12LV01B is immediately releasing the interface, the TSB12LV01B may assert the idle state for at most one clock cycle before it must assert either hold or transmit on the CTL terminals. The hold state is used by the TSB12LV01B to retain control of the bus while it prepares data for transmission. The TSB12LV01B may assert hold for zero or more clock cycles (i.e., the TSB12LV01B need not assert hold before transmit). The PHY asserts data-prefix on the serial bus during this time.

When the TSB12LV01B is ready to send data, the TSB12LV01B asserts transmit on the CTL terminals as well as sending the first bits of packet data on the D lines. The transmit state is held on the CTL terminals until the last bits of data has been sent. The TSB12LV01B then asserts either hold or idle on the CTL terminals for one clock cycle, and then asserts Idle for one additional cycle before releasing the interface bus and placing its CTL and D terminals in high-impedance. The PHY then regains control of the interface bus.

The hold state asserted at the end of packet transmission indicates to the PHY that the TSB12LV01B requests to send another packet (concatenated packet) without releasing the serial bus. The PHY responds to this concatenation request by waiting the required minimum packet separation time and then asserting grant, as before. This function may be used to send a unified response after sending an acknowledge, or to send consecutive isochronous packets during a single isochronous period. Unless multispeed concatenation is enabled, all packets transmitted during a single bus ownership must be of the same speed (since the speed of the packet is set before the first packet). If multispeed concatenation is enabled (when the EMSC bit of PHY register 5 is set), the TSB12LV01B must specify the speed code of the next concatenated packet on the D terminals when it asserts hold on the CTL terminals at the end of a packet. The encoding for this speed code is the same as the speed code that precedes received packet data as given in Table 7–11.

After sending the last packet for the current bus ownership, the TSB12LV01B releases the bus by asserting idle on the CTL terminals for two clock cycles. The PHY begins asserting idle on the CTL terminals one clock cycle after sampling idle from the link. Note, that whenever the D and CTL terminals change direction between the PHY and the TSB12LV01B, there is an extra clock period allowed so that both sides of the interface can operate on registered versions of the interface signals.

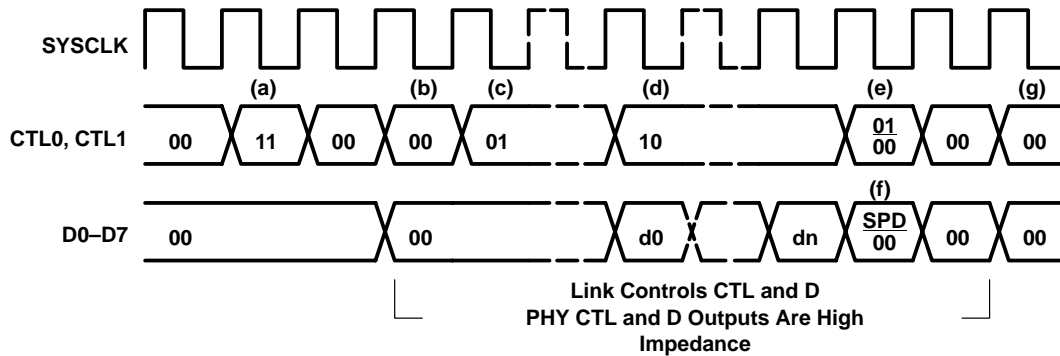

NOTE: SPD = Speed code, see Table 7-11. d0-dn = Packet data

Figure 7-6. Normal Packet Transmission Timing

The sequence of events for a normal packet transmission is as follows:

- Transmit operation initiated. The PHY asserts grant on the CTL lines followed by idle to hand over control of the interface to the link so that the link may transmit a packet. The PHY releases control of the interface (i.e., it places its CTL and D outputs in a high-impedance state) following the idle cycle.
- Optional idle cycle. The link may assert, at most, one Idle cycle preceding assertion of either hold or transmit. This idle cycle is optional; the link is not required to assert Idle preceding either hold or transmit.
- Optional hold cycles. The link may assert hold for up to 47 cycles preceding assertion of transmit. These hold cycle(s) are optional; the link is not required to assert hold preceding transmit.

PACKAGING INFORMATION

Orderable Device	Status (1)	Package Type	Package Drawing	Pins	Package Qty	Eco Plan (2)	Lead/Ball Finish (6)	MSL Peak Temp (3)	Op Temp (°C)	Device Marking (4/5)	Samples
TSB12LV01BIPZTEP	LIFEBUY	TQFP	PZT	100		TBD	Call TI	Call TI	-40 to 85	12LV01BIEP	
V62/03611-01XE	LIFEBUY	TQFP	PZT	100		TBD	Call TI	Call TI	-40 to 85	12LV01BIEP	

(1) The marketing status values are defined as follows:

ACTIVE: Product device recommended for new designs.

LIFEBUY: TI has announced that the device will be discontinued, and a lifetime-buy period is in effect.

NRND: Not recommended for new designs. Device is in production to support existing customers, but TI does not recommend using this part in a new design.

PREVIEW: Device has been announced but is not in production. Samples may or may not be available.

OBSOLETE: TI has discontinued the production of the device.

(2) **RoHS:** TI defines "RoHS" to mean semiconductor products that are compliant with the current EU RoHS requirements for all 10 RoHS substances, including the requirement that RoHS substance do not exceed 0.1% by weight in homogeneous materials. Where designed to be soldered at high temperatures, "RoHS" products are suitable for use in specified lead-free processes. TI may reference these types of products as "Pb-Free".

RoHS Exempt: TI defines "RoHS Exempt" to mean products that contain lead but are compliant with EU RoHS pursuant to a specific EU RoHS exemption.

Green: TI defines "Green" to mean the content of Chlorine (Cl) and Bromine (Br) based flame retardants meet JS709B low halogen requirements of <=1000ppm threshold. Antimony trioxide based flame retardants must also meet the <=1000ppm threshold requirement.

(3) MSL, Peak Temp. - The Moisture Sensitivity Level rating according to the JEDEC industry standard classifications, and peak solder temperature.

(4) There may be additional marking, which relates to the logo, the lot trace code information, or the environmental category on the device.

(5) Multiple Device Markings will be inside parentheses. Only one Device Marking contained in parentheses and separated by a "~" will appear on a device. If a line is indented then it is a continuation of the previous line and the two combined represent the entire Device Marking for that device.

(6) Lead/Ball Finish - Orderable Devices may have multiple material finish options. Finish options are separated by a vertical ruled line. Lead/Ball Finish values may wrap to two lines if the finish value exceeds the maximum column width.

Important Information and Disclaimer: The information provided on this page represents TI's knowledge and belief as of the date that it is provided. TI bases its knowledge and belief on information provided by third parties, and makes no representation or warranty as to the accuracy of such information. Efforts are underway to better integrate information from third parties. TI has taken and continues to take reasonable steps to provide representative and accurate information but may not have conducted destructive testing or chemical analysis on incoming materials and chemicals. TI and TI suppliers consider certain information to be proprietary, and thus CAS numbers and other limited information may not be available for release.

In no event shall TI's liability arising out of such information exceed the total purchase price of the TI part(s) at issue in this document sold by TI to Customer on an annual basis.

OTHER QUALIFIED VERSIONS OF TSB12LV01B-EP :

- Catalog: [TSB12LV01B](#)

NOTE: Qualified Version Definitions:

- Catalog - TI's standard catalog product

PZT (S-PQFP-G100)

PLASTIC QUAD FLATPACK

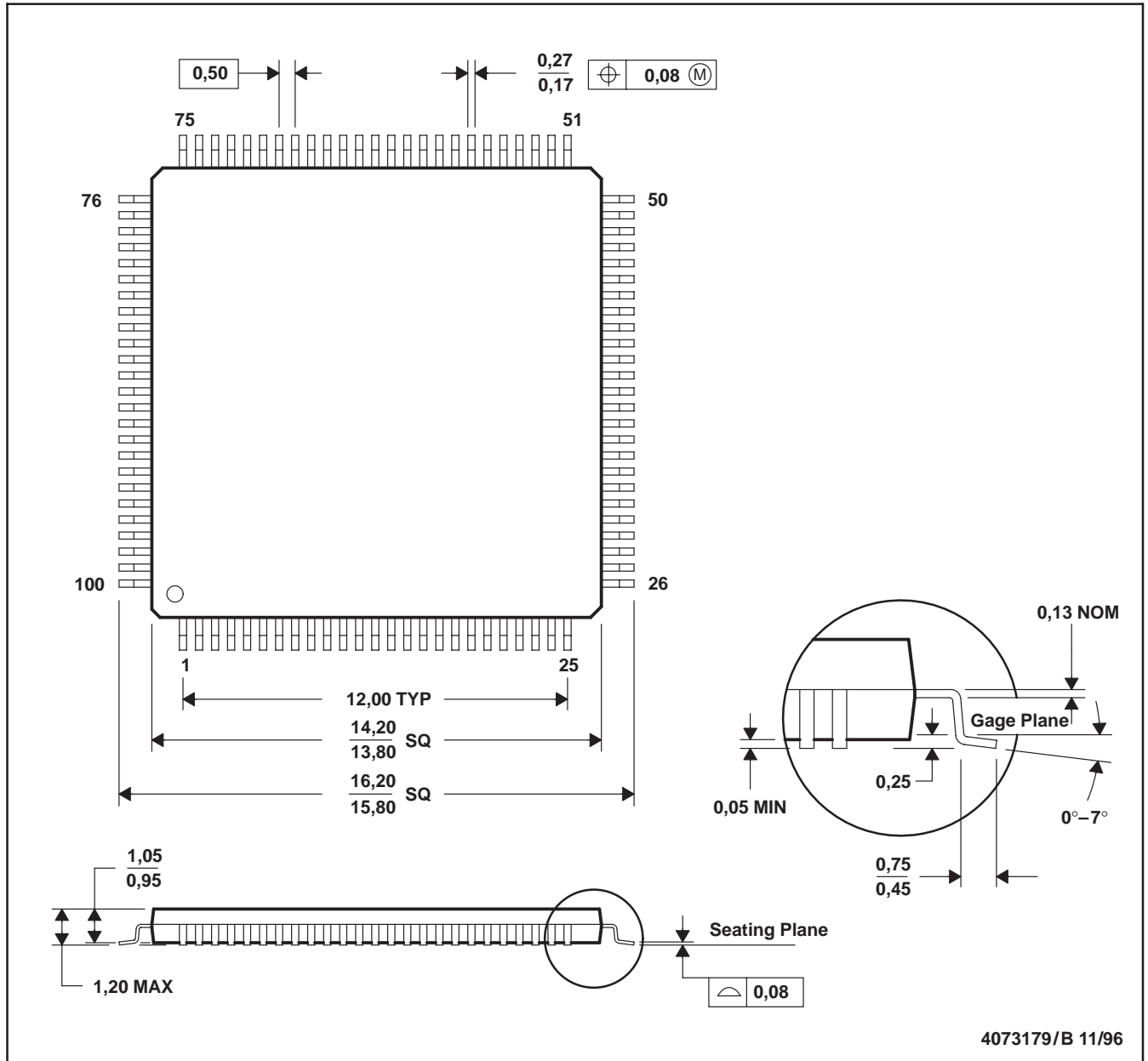

- NOTES: A. All linear dimensions are in millimeters.
 B. This drawing is subject to change without notice.
 C. Falls within JEDEC MS-026

IMPORTANT NOTICE

Texas Instruments Incorporated (TI) reserves the right to make corrections, enhancements, improvements and other changes to its semiconductor products and services per JESD46, latest issue, and to discontinue any product or service per JESD48, latest issue. Buyers should obtain the latest relevant information before placing orders and should verify that such information is current and complete.

TI's published terms of sale for semiconductor products (<http://www.ti.com/sc/docs/stdterms.htm>) apply to the sale of packaged integrated circuit products that TI has qualified and released to market. Additional terms may apply to the use or sale of other types of TI products and services.

Reproduction of significant portions of TI information in TI data sheets is permissible only if reproduction is without alteration and is accompanied by all associated warranties, conditions, limitations, and notices. TI is not responsible or liable for such reproduced documentation. Information of third parties may be subject to additional restrictions. Resale of TI products or services with statements different from or beyond the parameters stated by TI for that product or service voids all express and any implied warranties for the associated TI product or service and is an unfair and deceptive business practice. TI is not responsible or liable for any such statements.

Buyers and others who are developing systems that incorporate TI products (collectively, "Designers") understand and agree that Designers remain responsible for using their independent analysis, evaluation and judgment in designing their applications and that Designers have full and exclusive responsibility to assure the safety of Designers' applications and compliance of their applications (and of all TI products used in or for Designers' applications) with all applicable regulations, laws and other applicable requirements. Designer represents that, with respect to their applications, Designer has all the necessary expertise to create and implement safeguards that (1) anticipate dangerous consequences of failures, (2) monitor failures and their consequences, and (3) lessen the likelihood of failures that might cause harm and take appropriate actions. Designer agrees that prior to using or distributing any applications that include TI products, Designer will thoroughly test such applications and the functionality of such TI products as used in such applications.

TI's provision of technical, application or other design advice, quality characterization, reliability data or other services or information, including, but not limited to, reference designs and materials relating to evaluation modules, (collectively, "TI Resources") are intended to assist designers who are developing applications that incorporate TI products; by downloading, accessing or using TI Resources in any way, Designer (individually or, if Designer is acting on behalf of a company, Designer's company) agrees to use any particular TI Resource solely for this purpose and subject to the terms of this Notice.

TI's provision of TI Resources does not expand or otherwise alter TI's applicable published warranties or warranty disclaimers for TI products, and no additional obligations or liabilities arise from TI providing such TI Resources. TI reserves the right to make corrections, enhancements, improvements and other changes to its TI Resources. TI has not conducted any testing other than that specifically described in the published documentation for a particular TI Resource.

Designer is authorized to use, copy and modify any individual TI Resource only in connection with the development of applications that include the TI product(s) identified in such TI Resource. NO OTHER LICENSE, EXPRESS OR IMPLIED, BY ESTOPPEL OR OTHERWISE TO ANY OTHER TI INTELLECTUAL PROPERTY RIGHT, AND NO LICENSE TO ANY TECHNOLOGY OR INTELLECTUAL PROPERTY RIGHT OF TI OR ANY THIRD PARTY IS GRANTED HEREIN, including but not limited to any patent right, copyright, mask work right, or other intellectual property right relating to any combination, machine, or process in which TI products or services are used. Information regarding or referencing third-party products or services does not constitute a license to use such products or services, or a warranty or endorsement thereof. Use of TI Resources may require a license from a third party under the patents or other intellectual property of the third party, or a license from TI under the patents or other intellectual property of TI.

TI RESOURCES ARE PROVIDED "AS IS" AND WITH ALL FAULTS. TI DISCLAIMS ALL OTHER WARRANTIES OR REPRESENTATIONS, EXPRESS OR IMPLIED, REGARDING RESOURCES OR USE THEREOF, INCLUDING BUT NOT LIMITED TO ACCURACY OR COMPLETENESS, TITLE, ANY EPIDEMIC FAILURE WARRANTY AND ANY IMPLIED WARRANTIES OF MERCHANTABILITY, FITNESS FOR A PARTICULAR PURPOSE, AND NON-INFRINGEMENT OF ANY THIRD PARTY INTELLECTUAL PROPERTY RIGHTS. TI SHALL NOT BE LIABLE FOR AND SHALL NOT DEFEND OR INDEMNIFY DESIGNER AGAINST ANY CLAIM, INCLUDING BUT NOT LIMITED TO ANY INFRINGEMENT CLAIM THAT RELATES TO OR IS BASED ON ANY COMBINATION OF PRODUCTS EVEN IF DESCRIBED IN TI RESOURCES OR OTHERWISE. IN NO EVENT SHALL TI BE LIABLE FOR ANY ACTUAL, DIRECT, SPECIAL, COLLATERAL, INDIRECT, PUNITIVE, INCIDENTAL, CONSEQUENTIAL OR EXEMPLARY DAMAGES IN CONNECTION WITH OR ARISING OUT OF TI RESOURCES OR USE THEREOF, AND REGARDLESS OF WHETHER TI HAS BEEN ADVISED OF THE POSSIBILITY OF SUCH DAMAGES.

Unless TI has explicitly designated an individual product as meeting the requirements of a particular industry standard (e.g., ISO/TS 16949 and ISO 26262), TI is not responsible for any failure to meet such industry standard requirements.

Where TI specifically promotes products as facilitating functional safety or as compliant with industry functional safety standards, such products are intended to help enable customers to design and create their own applications that meet applicable functional safety standards and requirements. Using products in an application does not by itself establish any safety features in the application. Designers must ensure compliance with safety-related requirements and standards applicable to their applications. Designer may not use any TI products in life-critical medical equipment unless authorized officers of the parties have executed a special contract specifically governing such use. Life-critical medical equipment is medical equipment where failure of such equipment would cause serious bodily injury or death (e.g., life support, pacemakers, defibrillators, heart pumps, neurostimulators, and implantables). Such equipment includes, without limitation, all medical devices identified by the U.S. Food and Drug Administration as Class III devices and equivalent classifications outside the U.S.

TI may expressly designate certain products as completing a particular qualification (e.g., Q100, Military Grade, or Enhanced Product). Designers agree that it has the necessary expertise to select the product with the appropriate qualification designation for their applications and that proper product selection is at Designers' own risk. Designers are solely responsible for compliance with all legal and regulatory requirements in connection with such selection.

Designer will fully indemnify TI and its representatives against any damages, costs, losses, and/or liabilities arising out of Designer's non-compliance with the terms and provisions of this Notice.





Looking for pricing, stock, or lifecycle information?

Click below to explore more details on WIN SOURCE:

 [View TSB12LV01BIPZTEP on WIN SOURCE](#)

 [Texas Instruments](#) Information

Optimize Your Supply Chain with WIN SOURCE Solutions

-  Global Sourcing Solution
-  Obsolete Management
-  Cost Control Management
-  Shortage Management
-  Alternative Solution
-  Excess Inventory Management