



**THE DATASHEET OF
UA7815CKC**



μ A78xx Fixed Positive Voltage Regulators

1 Features

- 3-Terminal Regulators
- Available in fixed 5-V/8-V/10-V/12-V/15-V/24-V options
- Output Current up to 1.5 A
- Internal Thermal-Overload Protection
- High Power-Dissipation Capability
- Internal Short-Circuit Current Limiting
- Output Transistor Safe-Area Compensation
- Output Capacitor Not Needed for Stability

2 Applications

- On-card Regulation
- Portable Devices
- Computing & Servers
- Telecommunications

3 Description

This series of fixed-voltage integrated-circuit voltage regulators is designed for a wide range of applications. These applications include on-card regulation for elimination of noise and distribution problems associated with single-point regulation. Each of these regulators can deliver up to 1.5 A of output current. The internal current-limiting and thermal-shutdown features of these regulators essentially make them immune to overload. In addition to use as fixed-voltage regulators, these devices can be used with external components to obtain adjustable output voltages and currents, and also can be used as the power-pass element in precision regulators.

Device Information⁽¹⁾

PART NUMBER	PACKAGE	BODY SIZE (NOM)
μ A78xx	TO-220 (3)	10.16 mm x 8.82 mm
	TO-220 (3)	10.16 mm x 8.82 mm
	TO-263 (3)	10.06 mm x 9.02 mm

(1) For all available packages, see the orderable addendum at the end of the data sheet.

4 Simplified Schematic

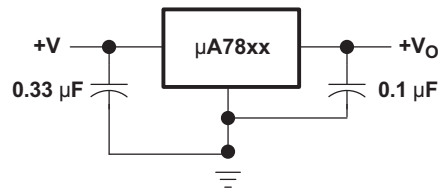

Table of Contents

1 Features	1	8 Detailed Description	11
2 Applications	1	8.1 Overview	11
3 Description	1	8.2 Functional Schematic.....	11
4 Simplified Schematic	1	8.3 Feature Description.....	11
5 Revision History	2	8.4 Device Functional Modes.....	11
6 Pin Configuration and Functions	3	9 Application and Implementation	12
7 Specifications	4	9.1 Application Information.....	12
7.1 Absolute Maximum Ratings	4	9.2 Typical Application	12
7.2 ESD Ratings	4	10 Power Supply Recommendations	14
7.3 Recommended Operating Conditions.....	4	11 Layout	15
7.4 Thermal Information	4	11.1 Layout Guidelines	15
7.5 Electrical Characteristics — uA7805.....	5	11.2 Layout Example	15
7.6 Electrical Characteristics — uA7808.....	6	12 Device and Documentation Support	15
7.7 Electrical Characteristics — uA7810.....	7	12.1 Related Links	15
7.8 Electrical Characteristics — uA7812	8	12.2 Trademarks	15
7.9 Electrical Characteristics — uA7815.....	9	12.3 Electrostatic Discharge Caution.....	15
7.10 Electrical Characteristics — uA7824.....	10	12.4 Glossary	15
7.11 Typical Characteristics	10	13 Mechanical, Packaging, and Orderable Information	15

5 Revision History

Changes from Revision O (August 2012) to Revision P

Page

- Added *Applications*, *Device Information* table, *Pin Functions* table, *ESD Ratings* table, *Thermal Information* table, *Typical Characteristics*, *Feature Description* section, *Device Functional Modes*, *Application and Implementation* section, *Power Supply Recommendations* section, *Layout* section, *Device and Documentation Support* section, and *Mechanical, Packaging, and Orderable Information* section. 1
- Deleted *Ordering Information* table. 1

6 Pin Configuration and Functions

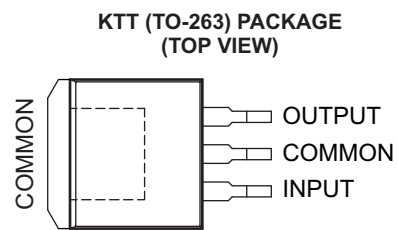
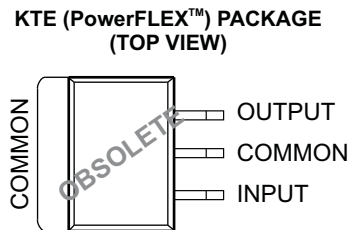
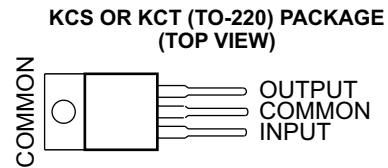
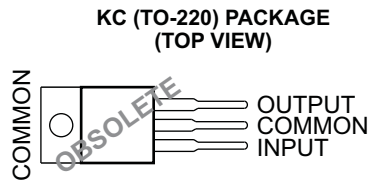

Pin Functions

PIN		TYPE	DESCRIPTION
NAME	NO.		
COMMON	2	—	Ground
INPUT	1	I	Supply Input
OUTPUT	3	O	Voltage Output

7 Specifications

7.1 Absolute Maximum Ratings

over virtual junction temperature range (unless otherwise noted)

		MIN	MAX	UNIT	
V _I	Input voltage	μA7824C	40	V	
		All others	35		
T _J	Operating virtual junction temperature		150	°C	
	Lead temperature	1,6 mm (1/16 in) from case for 10 s	260	°C	
T _{stg}	Storage temperature range		–65	150	°C

7.2 ESD Ratings

		VALUE	UNIT	
V _(ESD)	Electrostatic discharge	Human body model (HBM), per ANSI/ESDA/JEDEC JS-001, all pins ⁽¹⁾	3000	V
		Charged device model (CDM), per JEDEC specification JESD22-C101, all pins ⁽²⁾	2000	

(1) JEDEC document JEP155 states that 500-V HBM allows safe manufacturing with a standard ESD control process.

(2) JEDEC document JEP157 states that 250-V CDM allows safe manufacturing with a standard ESD control process.

7.3 Recommended Operating Conditions

		MIN	MAX	UNIT	
V _I	Input voltage	μA7805	7	25	V
		μA7808	10.5	25	
		μA7810	12.5	28	
		μA7812	14.5	30	
		μA7815	17.5	30	
		μA7824	27	38	
I _O	Output current		1.5	A	
T _J	Operating virtual junction temperature	0	125	°C	

7.4 Thermal Information

THERMAL METRIC ⁽¹⁾	μA78XX			UNIT	
	KTE	KCS, KCT, KC	KTT		
	3 PINS	3 PINS	3 PINS		
R _{θJA}	Junction-to-ambient thermal resistance	23	19	25.3	°C/W
R _{θJC(top)}	Junction-to-case (top) thermal resistance	3	17	18	
R _{θJP(top)}	Junction-to-exposed-pad thermal resistance	2.7	3	1.94	

(1) For more information about traditional and new thermal metrics, see the *IC Package Thermal Metrics* application report (SPRA953).

7.5 Electrical Characteristics — uA7805

at specified virtual junction temperature, $V_I = 10\text{ V}$, $I_O = 500\text{ mA}$ (unless otherwise noted)

PARAMETER	TEST CONDITIONS	T_J ⁽¹⁾	uA7805C			UNIT
			MIN	TYP	MAX	
Output voltage	$I_O = 5\text{ mA to }1\text{ A}$, $V_I = 7\text{ V to }20\text{ V}$, $P_D \leq 15\text{ W}$	25°C	4.8	5	5.2	V
		0°C to 125°C	4.75		5.25	
Input voltage regulation	$V_I = 7\text{ V to }25\text{ V}$	25°C		3	100	mV
	$V_I = 8\text{ V to }12\text{ V}$			1	50	
Ripple rejection ⁽²⁾	$V_I = 8\text{ V to }12\text{ V}$, $f = 120\text{ Hz}$	0°C to 125°C	62	78		dB
	$V_I = 8\text{ V to }12\text{ V}$, $f = 120\text{ Hz (KCT)}$			68		
Output voltage regulation	$I_O = 5\text{ mA to }1.5\text{ A}$	25°C		15	100	mV
	$I_O = 250\text{ mA to }750\text{ mA}$			5	50	
Output resistance	$f = 1\text{ kHz}$	0°C to 125°C		0.017		Ω
Temperature coefficient of output voltage	$I_O = 5\text{ mA}$	0°C to 125°C		-1.1		mV/°C
Output noise voltage	$f = 10\text{ Hz to }100\text{ kHz}$	25°C		40		μV
Dropout voltage	$I_O = 1\text{ A}$	25°C		2		V
Bias current		25°C		4.2	8	mA
Bias current change	$V_I = 7\text{ V to }25\text{ V}$	0°C to 125°C			1.3	mA
	$I_O = 5\text{ mA to }1\text{ A}$				0.5	
Short-circuit output current		25°C		750		mA
Peak output current		25°C		2.2		A

- (1) Pulse-testing techniques maintain the junction temperature as close to the ambient temperature as possible. Thermal effects must be taken into account separately. All characteristics are measured with a 0.33- μF capacitor across the input and a 0.1- μF capacitor across the output.
- (2) This parameter is validated by design and verified during product characterization. It is not tested in production.

7.6 Electrical Characteristics — uA7808

at specified virtual junction temperature, $V_I = 14\text{ V}$, $I_O = 500\text{ mA}$ (unless otherwise noted)

PARAMETER	TEST CONDITIONS	T_J ⁽¹⁾	μA7808C			UNIT
			MIN	TYP	MAX	
Output voltage	$I_O = 5\text{ mA to }1\text{ A}$, $V_I = 10.5\text{ V to }23\text{ V}$, $P_D \leq 15\text{ W}$	25°C	7.7	8	8.3	V
		0°C to 125°C	7.6		8.4	
Input voltage regulation	$V_I = 10.5\text{ V to }25\text{ V}$	25°C		6	160	mV
	$V_I = 11\text{ V to }17\text{ V}$			2	80	
Ripple rejection ⁽²⁾	$V_I = 11.5\text{ V to }21.5\text{ V}$, $f = 120\text{ Hz}$	0°C to 125°C	55	72		dB
	$V_I = 11.5\text{ V to }21.5\text{ V}$, $f = 120\text{ Hz}$ (KCT)			62		
Output voltage regulation	$I_O = 5\text{ mA to }1.5\text{ A}$	25°C		12	160	mV
	$I_O = 250\text{ mA to }750\text{ mA}$			4	80	
Output resistance	$f = 1\text{ kHz}$	0°C to 125°C		0.016		Ω
Temperature coefficient of output voltage	$I_O = 5\text{ mA}$	0°C to 125°C		-0.8		mV/°C
Output noise voltage	$f = 10\text{ Hz to }100\text{ kHz}$	25°C		52		μV
Dropout voltage	$I_O = 1\text{ A}$	25°C		2		V
Bias current		25°C		4.3	8	mA
Bias current change	$V_I = 10.5\text{ V to }25\text{ V}$	0°C to 125°C			1	mA
	$I_O = 5\text{ mA to }1\text{ A}$				0.5	
Short-circuit output current		25°C		450		mA
Peak output current		25°C		2.2		A

- (1) Pulse-testing techniques maintain the junction temperature as close to the ambient temperature as possible. Thermal effects must be taken into account separately. All characteristics are measured with a 0.33- μF capacitor across the input and a 0.1- μF capacitor across the output.
- (2) This parameter is validated by design and verified during product characterization. It is not tested in production.

7.7 Electrical Characteristics — uA7810

at specified virtual junction temperature, $V_I = 17\text{ V}$, $I_O = 500\text{ mA}$ (unless otherwise noted)

PARAMETER	TEST CONDITIONS	T_J ⁽¹⁾	uA7810C			UNIT
			MIN	TYP	MAX	
Output voltage	$I_O = 5\text{ mA to }1\text{ A}$, $V_I = 12.5\text{ V to }25\text{ V}$, $P_D \leq 15\text{ W}$	25°C	9.6	10	10.4	V
		0°C to 125°C	9.5		10.5	
Input voltage regulation	$V_I = 12.5\text{ V to }28\text{ V}$	25°C		7	200	mV
	$V_I = 14\text{ V to }20\text{ V}$			2	100	
Ripple rejection ⁽²⁾	$V_I = 13\text{ V to }23\text{ V}$, $f = 120\text{ Hz}$	0°C to 125°C	55	71		dB
Output voltage regulation	$I_O = 5\text{ mA to }1.5\text{ A}$	25°C		12	200	mV
	$I_O = 250\text{ mA to }750\text{ mA}$			4	100	
Output resistance	$f = 1\text{ kHz}$	0°C to 125°C		0.018		Ω
Temperature coefficient of output voltage	$I_O = 5\text{ mA}$	0°C to 125°C		-1		mV/°C
Output noise voltage	$f = 10\text{ Hz to }100\text{ kHz}$	25°C		70		μV
Dropout voltage	$I_O = 1\text{ A}$	25°C		2		V
Bias current		25°C		4.3	8	mA
Bias current change	$V_I = 12.5\text{ V to }28\text{ V}$	0°C to 125°C			1	mA
	$I_O = 5\text{ mA to }1\text{ A}$				0.5	
Short-circuit output current		25°C		400		mA
Peak output current		25°C		2.2		A

- (1) Pulse-testing techniques maintain the junction temperature as close to the ambient temperature as possible. Thermal effects must be taken into account separately. All characteristics are measured with a 0.33- μF capacitor across the input and a 0.1- μF capacitor across the output.
- (2) This parameter is validated by design and verified during product characterization. It is not tested in production.

7.8 Electrical Characteristics — uA7812

at specified virtual junction temperature, $V_I = 19\text{ V}$, $I_O = 500\text{ mA}$ (unless otherwise noted)

PARAMETER	TEST CONDITIONS	T_J ⁽¹⁾	uA7812C			UNIT
			MIN	TYP	MAX	
Output voltage	$I_O = 5\text{ mA to }1\text{ A}$, $V_I = 14.5\text{ V to }27\text{ V}$, $P_D \leq 15\text{ W}$	25°C	11.5	12	12.5	V
		0°C to 125°C	11.4		12.6	
Input voltage regulation	$V_I = 14.5\text{ V to }30\text{ V}$	25°C		10	240	mV
	$V_I = 16\text{ V to }22\text{ V}$			3	120	
Ripple rejection ⁽²⁾	$V_I = 15\text{ V to }25\text{ V}$, $f = 120\text{ Hz}$	0°C to 125°C	55	71		dB
	$V_I = 15\text{ V to }25\text{ V}$, $f = 120\text{ Hz (KCT)}$			61		
Output voltage regulation	$I_O = 5\text{ mA to }1.5\text{ A}$	25°C		12	240	mV
	$I_O = 250\text{ mA to }750\text{ mA}$			4	120	
Output resistance	$f = 1\text{ kHz}$	0°C to 125°C		0.018		Ω
Temperature coefficient of output voltage	$I_O = 5\text{ mA}$	0°C to 125°C		-1		mV/°C
Output noise voltage	$f = 10\text{ Hz to }100\text{ kHz}$	25°C		75		μV
Dropout voltage	$I_O = 1\text{ A}$	25°C		2		V
Bias current		25°C		4.3	8	mA
Bias current change	$V_I = 14.5\text{ V to }30\text{ V}$	0°C to 125°C			1	mA
	$I_O = 5\text{ mA to }1\text{ A}$				0.5	
Short-circuit output current		25°C		350		mA
Peak output current		25°C		2.2		A

- (1) Pulse-testing techniques maintain the junction temperature as close to the ambient temperature as possible. Thermal effects must be taken into account separately. All characteristics are measured with a 0.33- μF capacitor across the input and a 0.1- μF capacitor across the output.
- (2) This parameter is validated by design and verified during product characterization. It is not tested in production.

7.9 Electrical Characteristics — uA7815

at specified virtual junction temperature, $V_I = 23\text{ V}$, $I_O = 500\text{ mA}$ (unless otherwise noted)

PARAMETER	TEST CONDITIONS	T_J ⁽¹⁾	μA7815C			UNIT
			MIN	TYP	MAX	
Output voltage	$I_O = 5\text{ mA to }1\text{ A}$, $V_I = 17.5\text{ V to }30\text{ V}$, $P_D \leq 15\text{ W}$	25°C	14.4	15	15.6	V
		0°C to 125°C	14.25		15.75	
Input voltage regulation	$V_I = 17.5\text{ V to }30\text{ V}$	25°C		11	300	mV
	$V_I = 20\text{ V to }26\text{ V}$			3	150	
Ripple rejection ⁽²⁾	$V_I = 18.5\text{ V to }28.5\text{ V}$, $f = 120\text{ Hz}$	0°C to 125°C	54	70		dB
	$V_I = 18.5\text{ V to }28.5\text{ V}$, $f = 120\text{ Hz}$ (KCT)			60		
Output voltage regulation	$I_O = 5\text{ mA to }1.5\text{ A}$	25°C		12	300	mV
	$I_O = 250\text{ mA to }750\text{ mA}$			4	150	
Output resistance	$f = 1\text{ kHz}$	0°C to 125°C		0.019		Ω
Temperature coefficient of output voltage	$I_O = 5\text{ mA}$	0°C to 125°C		-1		mV/°C
Output noise voltage	$f = 10\text{ Hz to }100\text{ kHz}$	25°C		90		μV
Dropout voltage	$I_O = 1\text{ A}$	25°C		2		V
Bias current		25°C		4.4	8	mA
Bias current change	$V_I = 17.5\text{ V to }30\text{ V}$	0°C to 125°C			1	mA
	$I_O = 5\text{ mA to }1\text{ A}$				0.5	
Short-circuit output current		25°C		230		mA
Peak output current		25°C		2.1		A

- (1) Pulse-testing techniques maintain the junction temperature as close to the ambient temperature as possible. Thermal effects must be taken into account separately. All characteristics are measured with a 0.33-μF capacitor across the input and a 0.1-μF capacitor across the output.
- (2) This parameter is validated by design and verified during product characterization. It is not tested in production.

7.10 Electrical Characteristics — uA7824

at specified virtual junction temperature, $V_I = 33\text{ V}$, $I_O = 500\text{ mA}$ (unless otherwise noted)

PARAMETER	TEST CONDITIONS	T_J ⁽¹⁾	μA7824C			UNIT
			MIN	TYP	MAX	
Output voltage	$I_O = 5\text{ mA to } 1\text{ A}$, $V_I = 27\text{ V to } 38\text{ V}$, $P_D \leq 15\text{ W}$	25°C	23	24	25	V
		0°C to 125°C	22.8		25.2	
Input voltage regulation	$V_I = 27\text{ V to } 38\text{ V}$	25°C		18	480	mV
	$V_I = 30\text{ V to } 36\text{ V}$			6	240	
Ripple rejection ⁽²⁾	$V_I = 28\text{ V to } 38\text{ V}$, $f = 120\text{ Hz}$	0°C to 125°C	50	66		dB
Output voltage regulation	$I_O = 5\text{ mA to } 1.5\text{ A}$	25°C		12	480	mV
	$I_O = 250\text{ mA to } 750\text{ mA}$			4	240	
Output resistance	$f = 1\text{ kHz}$	0°C to 125°C		0.028		Ω
Temperature coefficient of output voltage	$I_O = 5\text{ mA}$	0°C to 125°C		-1.5		mV/°C
Output noise voltage	$f = 10\text{ Hz to } 100\text{ kHz}$	25°C		170		μV
Dropout voltage	$I_O = 1\text{ A}$	25°C		2		V
Bias current		25°C		4.6	8	mA
Bias current change	$V_I = 27\text{ V to } 38\text{ V}$	0°C to 125°C			1	mA
	$I_O = 5\text{ mA to } 1\text{ A}$				0.5	
Short-circuit output current		25°C		150		mA
Peak output current		25°C		2.1		A

- (1) Pulse-testing techniques maintain the junction temperature as close to the ambient temperature as possible. Thermal effects must be taken into account separately. All characteristics are measured with a 0.33- μF capacitor across the input and a 0.1- μF capacitor across the output.
- (2) This parameter is validated by design and verified during product characterization. It is not tested in production.

7.11 Typical Characteristics

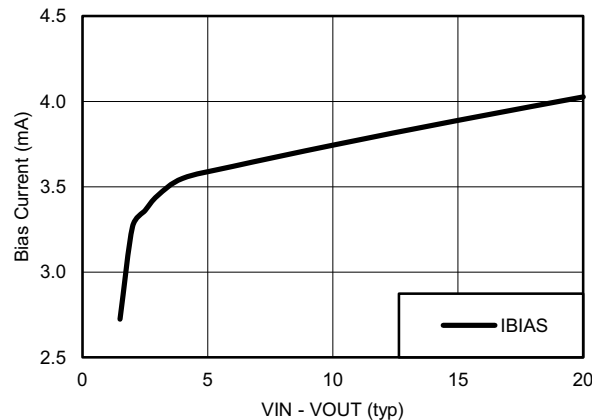

Figure 1. μA7805 Bias Current vs Voltage Differential at 25°C

8 Detailed Description

8.1 Overview

This series of fixed-voltage integrated-circuit voltage regulators is designed for a wide range of applications. These applications include on-card regulation for elimination of noise and distribution problems associated with single-point regulation. Each of these regulators can deliver up to 1.5 A of output current. The internal current-limiting and thermal-shutdown features of these regulators essentially make them immune to overload. In addition to use as fixed-voltage regulators, these devices can be used with external components to obtain adjustable output voltages and currents, and also can be used as the power-pass element in precision regulators.

8.2 Functional Schematic

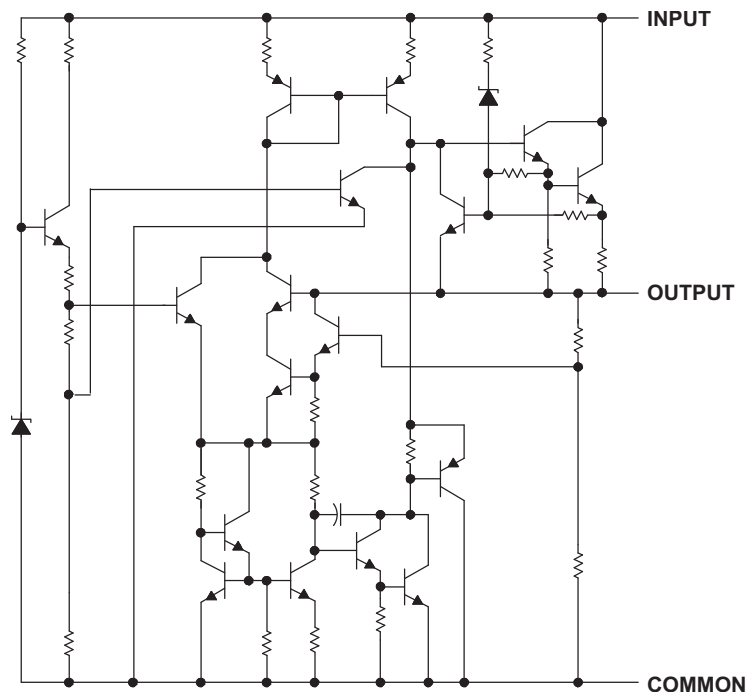

8.3 Feature Description

8.3.1 Thermal Overload

When the die temperature increases to unwanted levels, the device will reduce the output current to lower its temperature. Under heavy loads, the device may alternate between on and off output states to regulate temperature.

8.3.2 Short-Circuit Current Limiting

In the event of a short circuit, the device will limit its own current to safe levels by lowering the bias voltage of internal pass transistors. If the device becomes overheated, the thermal overload protection will take over.

8.4 Device Functional Modes

8.4.1 Fixed-Output Mode

These devices are available in fixed-output voltages. See the orderable part list for the desired output.

9 Application and Implementation

NOTE

Information in the following applications sections is not part of the TI component specification, and TI does not warrant its accuracy or completeness. TI's customers are responsible for determining suitability of components for their purposes. Customers should validate and test their design implementation to confirm system functionality.

9.1 Application Information

The following section shows application details of the μ A78xx as a linear regulator.

9.2 Typical Application

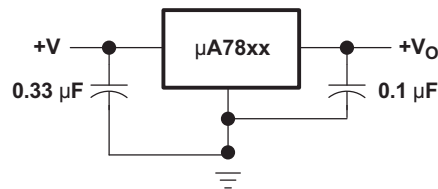

Figure 2. Fixed-Output Regulator

9.2.1 Design Requirements

- Input supply capacitor recommended for filtering noise on the input
- Output supply decoupling capacitor for stabilizing the output

9.2.2 Detailed Design Procedure

9.2.2.1 Operation With a Load Common to a Voltage of Opposite Polarity

In many cases, a regulator powers a load that is not connected to ground but, instead, is connected to a voltage source of opposite polarity (e.g., operational amplifiers, level-shifting circuits, etc.). In these cases, a clamp diode should be connected to the regulator output as shown in Figure 3. This protects the regulator from output polarity reversals during startup and short-circuit operation.

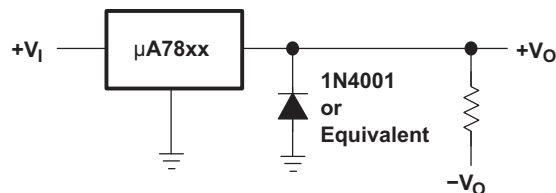

Figure 3. Output Polarity-Reversal-Protection Circuit

9.2.2.2 Reverse-Bias Protection

Occasionally, the input voltage to the regulator can collapse faster than the output voltage. This can occur, for example, when the input supply is crowbarred during an output overvoltage condition. If the output voltage is greater than approximately 7 V, the emitter-base junction of the series-pass element (internal or external) could break down and be damaged. To prevent this, a diode shunt can be used as shown in Figure 4.

Typical Application (continued)

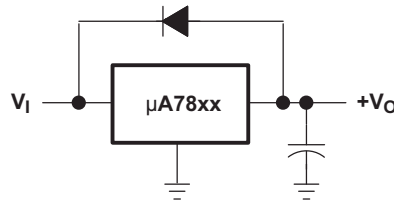

Figure 4. Reverse-Bias-Protection Circuit

9.2.3 Application Curves

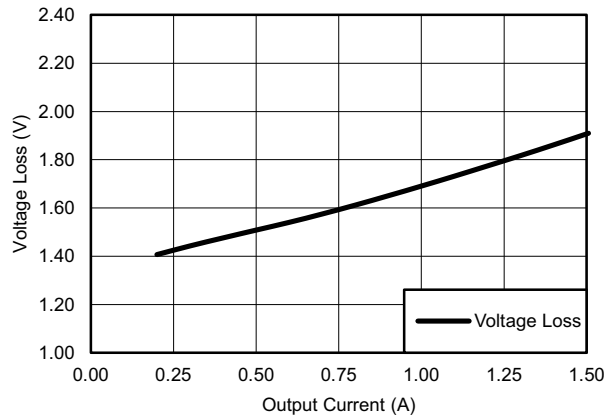

Figure 5. μA7805 Voltage Loss vs Output Current at 25°C

9.2.4 General Configurations

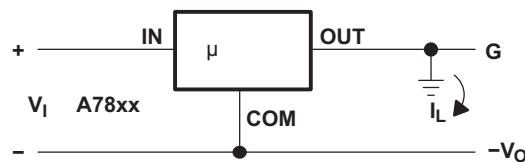
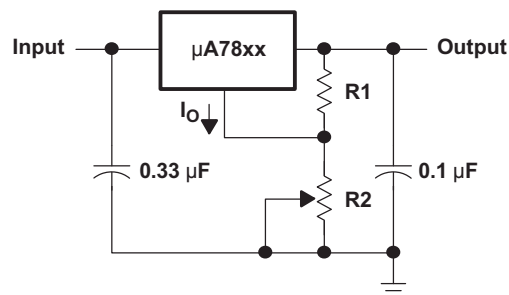

Figure 6. Positive Regulator in Negative Configuration (V_I Must Float)



A: The following formula is used when V_{xx} is the nominal output voltage (output to common) of the fixed regulators

$$V_o = V_{xx} + \left(\frac{V_{xx}}{R1} + I_o \right) R2$$

Figure 7. Adjustable-Output Regulator

Typical Application (continued)

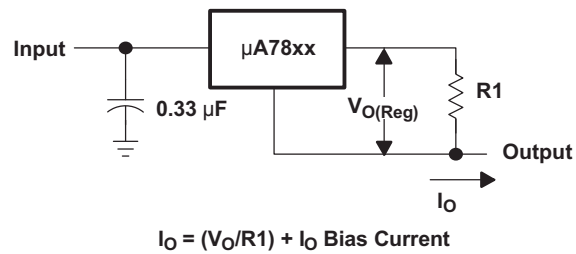

Figure 8. Current Regulator

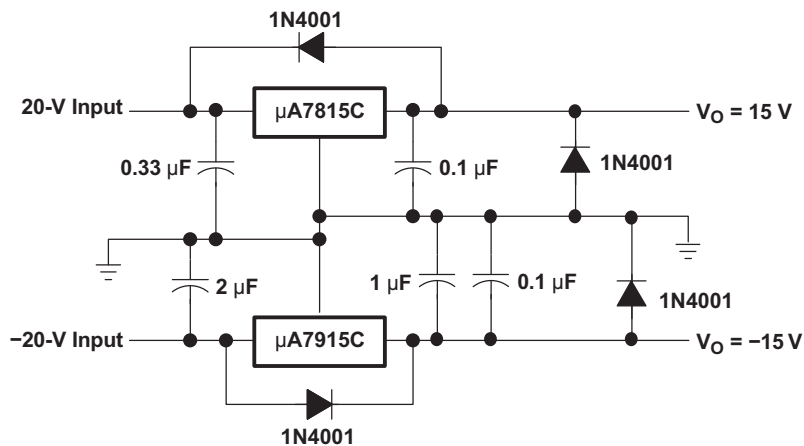

Figure 9. Regulated Dual Supply

10 Power Supply Recommendations

See [Recommended Operating Conditions](#) for the recommended power supply voltages for each variation of the μA78xx device. Different orderable part numbers will be able to tolerate different levels of voltage. It is also recommended to have a decoupling capacitor on the output of the μA78xx device's power supply to limit noise on the device input.

11 Layout

11.1 Layout Guidelines

Keep trace widths large enough to eliminate problematic I×R voltage drops at the input and output terminals. Input decoupling capacitors should be placed as close to the μA78XX as possible.

11.2 Layout Example

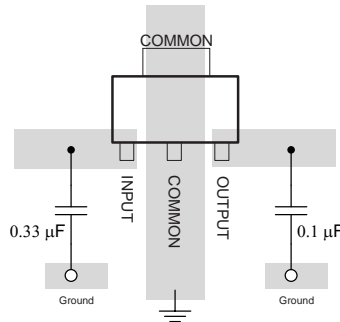

Figure 10. Layout Diagram

12 Device and Documentation Support

12.1 Related Links

The table below lists quick access links. Categories include technical documents, support and community resources, tools and software, and quick access to sample or buy.

Table 1. Related Links

PARTS	PRODUCT FOLDER	SAMPLE & BUY	TECHNICAL DOCUMENTS	TOOLS & SOFTWARE	SUPPORT & COMMUNITY
μA7805	Click here	Click here	Click here	Click here	Click here
uA7808	Click here	Click here	Click here	Click here	Click here
uA7810	Click here	Click here	Click here	Click here	Click here
uA7812	Click here	Click here	Click here	Click here	Click here
uA7815	Click here	Click here	Click here	Click here	Click here
uA7924	Click here	Click here	Click here	Click here	Click here

12.2 Trademarks

12.3 Electrostatic Discharge Caution



These devices have limited built-in ESD protection. The leads should be shorted together or the device placed in conductive foam during storage or handling to prevent electrostatic damage to the MOS gates.

12.4 Glossary

[SLYZ022](#) — *TI Glossary*.

This glossary lists and explains terms, acronyms, and definitions.

13 Mechanical, Packaging, and Orderable Information

The following pages include mechanical, packaging, and orderable information. This information is the most current data available for the designated devices. This data is subject to change without notice and revision of this document. For browser-based versions of this data sheet, refer to the left-hand navigation.

PACKAGING INFORMATION

Orderable Device	Status (1)	Package Type	Package Drawing	Pins	Package Qty	Eco Plan (2)	Lead/Ball Finish (6)	MSL Peak Temp (3)	Op Temp (°C)	Device Marking (4/5)	Samples
UA7805CKC	OBSOLETE	TO-220	KC	3		TBD	Call TI	Call TI	0 to 125	UA7805C	
UA7805CKCE3	OBSOLETE	TO-220	KC	3		TBD	Call TI	Call TI	0 to 125	UA7805C	
UA7805CKCS	ACTIVE	TO-220	KCS	3	50	Pb-Free (RoHS)	CU SN	N / A for Pkg Type	0 to 125	UA7805C	Samples
UA7805CKCSE3	ACTIVE	TO-220	KCS	3	50	Pb-Free (RoHS)	CU SN	N / A for Pkg Type	0 to 125	UA7805C	Samples
UA7805CKCT	ACTIVE	TO-220	KCT	3	50	Pb-Free (RoHS)	CU SN	N / A for Pkg Type	0 to 125	UA7805C	Samples
UA7805CKTER	OBSOLETE	PFM	KTE	3		TBD	Call TI	Call TI	0 to 125	UA7805C	
UA7805CKTTR	ACTIVE	DDPAK/ TO-263	KTT	3	500	Green (RoHS & no Sb/Br)	CU SN	Level-3-245C-168 HR	0 to 125	UA7805C	Samples
UA7805CKTTRG3	ACTIVE	DDPAK/ TO-263	KTT	3	500	Green (RoHS & no Sb/Br)	CU SN	Level-3-245C-168 HR	0 to 125	UA7805C	Samples
UA7805QKC	OBSOLETE	TO-220	KC	3		TBD	Call TI	Call TI	-40 to 125		
UA7805QKTE	OBSOLETE	PFM	KTE	3		TBD	Call TI	Call TI	-40 to 125		
UA7808CKC	OBSOLETE	TO-220	KC	3		TBD	Call TI	Call TI	0 to 125	UA7808C	
UA7808CKCE3	OBSOLETE	TO-220	KC	3		TBD	Call TI	Call TI	0 to 125	UA7808C	
UA7808CKCS	ACTIVE	TO-220	KCS	3	50	Pb-Free (RoHS)	CU SN	N / A for Pkg Type	0 to 125	UA7808C	Samples
UA7808CKCSE3	ACTIVE	TO-220	KCS	3	50	Pb-Free (RoHS)	CU SN	N / A for Pkg Type	0 to 125	UA7808C	Samples
UA7808CKCT	ACTIVE	TO-220	KCT	3	50	Pb-Free (RoHS)	CU SN	N / A for Pkg Type	0 to 125	UA7808C	Samples
UA7808CKTER	OBSOLETE	PFM	KTE	3		TBD	Call TI	Call TI	0 to 125	UA7808C	
UA7808CKTTR	ACTIVE	DDPAK/ TO-263	KTT	3	500	Green (RoHS & no Sb/Br)	CU SN	Level-3-245C-168 HR	0 to 125	UA7808C	Samples
UA7808CKTTRG3	ACTIVE	DDPAK/ TO-263	KTT	3	500	Green (RoHS & no Sb/Br)	CU SN	Level-3-245C-168 HR	0 to 125	UA7808C	Samples
UA7808QKTE	OBSOLETE	PFM	KTE	3		TBD	Call TI	Call TI	-40 to 125		
UA7810-W	ACTIVE	WAFERSALE	YS	0	3952	TBD	Call TI	Call TI			Samples
UA7810CKC	OBSOLETE	TO-220	KC	3		TBD	Call TI	Call TI	0 to 125	UA7810C	
UA7810CKCE3	OBSOLETE	TO-220	KC	3		TBD	Call TI	Call TI	0 to 125	UA7810C	

Orderable Device	Status (1)	Package Type	Package Drawing	Pins	Package Qty	Eco Plan (2)	Lead/Ball Finish (6)	MSL Peak Temp (3)	Op Temp (°C)	Device Marking (4/5)	Samples
UA7810CKCS	ACTIVE	TO-220	KCS	3	50	Pb-Free (RoHS)	CU SN	N / A for Pkg Type	0 to 125	UA7810C	Samples
UA7810CKCSE3	ACTIVE	TO-220	KCS	3	50	Pb-Free (RoHS)	CU SN	N / A for Pkg Type	0 to 125	UA7810C	Samples
UA7810CKTER	OBSOLETE	PFM	KTE	3		TBD	Call TI	Call TI	0 to 125	UA7810C	
UA7810CKTTR	ACTIVE	DDPAK/ TO-263	KTT	3	500	Green (RoHS & no Sb/Br)	CU SN	Level-3-245C-168 HR	0 to 125	UA7810C	Samples
UA7810CKTTRG3	ACTIVE	DDPAK/ TO-263	KTT	3	500	Green (RoHS & no Sb/Br)	CU SN	Level-3-245C-168 HR	0 to 125	UA7810C	Samples
UA7810QKTE	OBSOLETE	PFM	KTE	3		TBD	Call TI	Call TI	-40 to 125		
UA7812CKC	OBSOLETE	TO-220	KC	3		TBD	Call TI	Call TI	0 to 125	UA7812C	
UA7812CKCE3	OBSOLETE	TO-220	KC	3		TBD	Call TI	Call TI		UA7812C	
UA7812CKCS	ACTIVE	TO-220	KCS	3	50	Pb-Free (RoHS)	CU SN	N / A for Pkg Type	0 to 125	UA7812C	Samples
UA7812CKCSE3	ACTIVE	TO-220	KCS	3	50	Pb-Free (RoHS)	CU SN	N / A for Pkg Type	0 to 125	UA7812C	Samples
UA7812CKCT	ACTIVE	TO-220	KCT	3	50	Pb-Free (RoHS)	CU SN	N / A for Pkg Type	0 to 125	UA7812C	Samples
UA7812CKTER	OBSOLETE	PFM	KTE	3		TBD	Call TI	Call TI	0 to 125	UA7812C	
UA7812CKTTR	ACTIVE	DDPAK/ TO-263	KTT	3	500	Green (RoHS & no Sb/Br)	CU SN	Level-3-245C-168 HR	0 to 125	UA7812C	Samples
UA7812CKTTRG3	ACTIVE	DDPAK/ TO-263	KTT	3	500	Green (RoHS & no Sb/Br)	CU SN	Level-3-245C-168 HR	0 to 125	UA7812C	Samples
UA7812QKTE	OBSOLETE	PFM	KTE	3		TBD	Call TI	Call TI	-40 to 125		
UA7815CKC	OBSOLETE	TO-220	KC	3		TBD	Call TI	Call TI	0 to 125	UA7815C	
UA7815CKCS	ACTIVE	TO-220	KCS	3	50	Pb-Free (RoHS)	CU SN	N / A for Pkg Type	0 to 125	UA7815C	Samples
UA7815CKCSE3	ACTIVE	TO-220	KCS	3	50	Pb-Free (RoHS)	CU SN	N / A for Pkg Type	0 to 125	UA7815C	Samples
UA7815CKCT	ACTIVE	TO-220	KCT	3	50	Pb-Free (RoHS)	CU SN	N / A for Pkg Type	0 to 125	UA7815C	Samples
UA7815CKTER	OBSOLETE	PFM	KTE	3		TBD	Call TI	Call TI	0 to 125	UA7815C	
UA7815CKTTR	ACTIVE	DDPAK/ TO-263	KTT	3	500	Green (RoHS & no Sb/Br)	CU SN	Level-3-245C-168 HR	0 to 125	UA7815C	Samples
UA7815QKTE	OBSOLETE	PFM	KTE	3		TBD	Call TI	Call TI			

Orderable Device	Status (1)	Package Type	Package Drawing	Pins	Package Qty	Eco Plan (2)	Lead/Ball Finish (6)	MSL Peak Temp (3)	Op Temp (°C)	Device Marking (4/5)	Samples
UA7824CKC	OBSOLETE	TO-220	KC	3		TBD	Call TI	Call TI	0 to 125	UA7824C	
UA7824CKCE3	OBSOLETE	TO-220	KC	3		TBD	Call TI	Call TI	0 to 125	UA7824C	
UA7824CKCS	ACTIVE	TO-220	KCS	3	50	Pb-Free (RoHS)	CU SN	N / A for Pkg Type	0 to 125	UA7824C	Samples
UA7824CKCSE3	ACTIVE	TO-220	KCS	3	50	Pb-Free (RoHS)	CU SN	N / A for Pkg Type	0 to 125	UA7824C	Samples
UA7824CKTER	OBSOLETE	PFM	KTE	3		TBD	Call TI	Call TI	0 to 125	UA7824C	
UA7824CKTTR	ACTIVE	DDPAK/ TO-263	KTT	3	500	Green (RoHS & no Sb/Br)	CU SN	Level-3-245C-168 HR	0 to 125	UA7824C	Samples
UA7885CKC	OBSOLETE	TO-220	KC	3		TBD	Call TI	Call TI			
UA7885CKTER	OBSOLETE	PFM	KTE	3		TBD	Call TI	Call TI			
UA7885QKTE	OBSOLETE	PFM	KTE	3		TBD	Call TI	Call TI			

(1) The marketing status values are defined as follows:

ACTIVE: Product device recommended for new designs.

LIFEBUY: TI has announced that the device will be discontinued, and a lifetime-buy period is in effect.

NRND: Not recommended for new designs. Device is in production to support existing customers, but TI does not recommend using this part in a new design.

PREVIEW: Device has been announced but is not in production. Samples may or may not be available.

OBSOLETE: TI has discontinued the production of the device.

(2) Eco Plan - The planned eco-friendly classification: Pb-Free (RoHS), Pb-Free (RoHS Exempt), or Green (RoHS & no Sb/Br) - please check <http://www.ti.com/productcontent> for the latest availability information and additional product content details.

TBD: The Pb-Free/Green conversion plan has not been defined.

Pb-Free (RoHS): TI's terms "Lead-Free" or "Pb-Free" mean semiconductor products that are compatible with the current RoHS requirements for all 6 substances, including the requirement that lead not exceed 0.1% by weight in homogeneous materials. Where designed to be soldered at high temperatures, TI Pb-Free products are suitable for use in specified lead-free processes.

Pb-Free (RoHS Exempt): This component has a RoHS exemption for either 1) lead-based flip-chip solder bumps used between the die and package, or 2) lead-based die adhesive used between the die and leadframe. The component is otherwise considered Pb-Free (RoHS compatible) as defined above.

Green (RoHS & no Sb/Br): TI defines "Green" to mean Pb-Free (RoHS compatible), and free of Bromine (Br) and Antimony (Sb) based flame retardants (Br or Sb do not exceed 0.1% by weight in homogeneous material)

(3) MSL, Peak Temp. - The Moisture Sensitivity Level rating according to the JEDEC industry standard classifications, and peak solder temperature.

(4) There may be additional marking, which relates to the logo, the lot trace code information, or the environmental category on the device.

(5) Multiple Device Markings will be inside parentheses. Only one Device Marking contained in parentheses and separated by a "-" will appear on a device. If a line is indented then it is a continuation of the previous line and the two combined represent the entire Device Marking for that device.

⁽⁶⁾ Lead/Ball Finish - Orderable Devices may have multiple material finish options. Finish options are separated by a vertical ruled line. Lead/Ball Finish values may wrap to two lines if the finish value exceeds the maximum column width.

Important Information and Disclaimer:The information provided on this page represents TI's knowledge and belief as of the date that it is provided. TI bases its knowledge and belief on information provided by third parties, and makes no representation or warranty as to the accuracy of such information. Efforts are underway to better integrate information from third parties. TI has taken and continues to take reasonable steps to provide representative and accurate information but may not have conducted destructive testing or chemical analysis on incoming materials and chemicals. TI and TI suppliers consider certain information to be proprietary, and thus CAS numbers and other limited information may not be available for release.

In no event shall TI's liability arising out of such information exceed the total purchase price of the TI part(s) at issue in this document sold by TI to Customer on an annual basis.

TAPE AND REEL INFORMATION

QUADRANT ASSIGNMENTS FOR PIN 1 ORIENTATION IN TAPE

*All dimensions are nominal

Device	Package Type	Package Drawing	Pins	SPQ	Reel Diameter (mm)	Reel Width W1 (mm)	A0 (mm)	B0 (mm)	K0 (mm)	P1 (mm)	W (mm)	Pin1 Quadrant
UA7805CKTTR	DDPAK/ TO-263	KTT	3	500	330.0	24.4	10.8	16.3	5.11	16.0	24.0	Q2
UA7808CKTTR	DDPAK/ TO-263	KTT	3	500	330.0	24.4	10.8	16.3	5.11	16.0	24.0	Q2
UA7810CKTTR	DDPAK/ TO-263	KTT	3	500	330.0	24.4	10.8	16.3	5.11	16.0	24.0	Q2
UA7812CKTTR	DDPAK/ TO-263	KTT	3	500	330.0	24.4	10.8	16.3	5.11	16.0	24.0	Q2
UA7815CKTTR	DDPAK/ TO-263	KTT	3	500	330.0	24.4	10.8	16.3	5.11	16.0	24.0	Q2
UA7824CKTTR	DDPAK/ TO-263	KTT	3	500	330.0	24.4	10.8	16.3	5.11	16.0	24.0	Q2

TAPE AND REEL BOX DIMENSIONS

*All dimensions are nominal

Device	Package Type	Package Drawing	Pins	SPQ	Length (mm)	Width (mm)	Height (mm)
UA7805CKTTR	DDPAK/TO-263	KTT	3	500	340.0	340.0	38.0
UA7808CKTTR	DDPAK/TO-263	KTT	3	500	340.0	340.0	38.0
UA7810CKTTR	DDPAK/TO-263	KTT	3	500	340.0	340.0	38.0
UA7812CKTTR	DDPAK/TO-263	KTT	3	500	340.0	340.0	38.0
UA7815CKTTR	DDPAK/TO-263	KTT	3	500	340.0	340.0	38.0
UA7824CKTTR	DDPAK/TO-263	KTT	3	500	340.0	340.0	38.0

KTT (R-PSFM-G3)

PLASTIC FLANGE-MOUNT PACKAGE

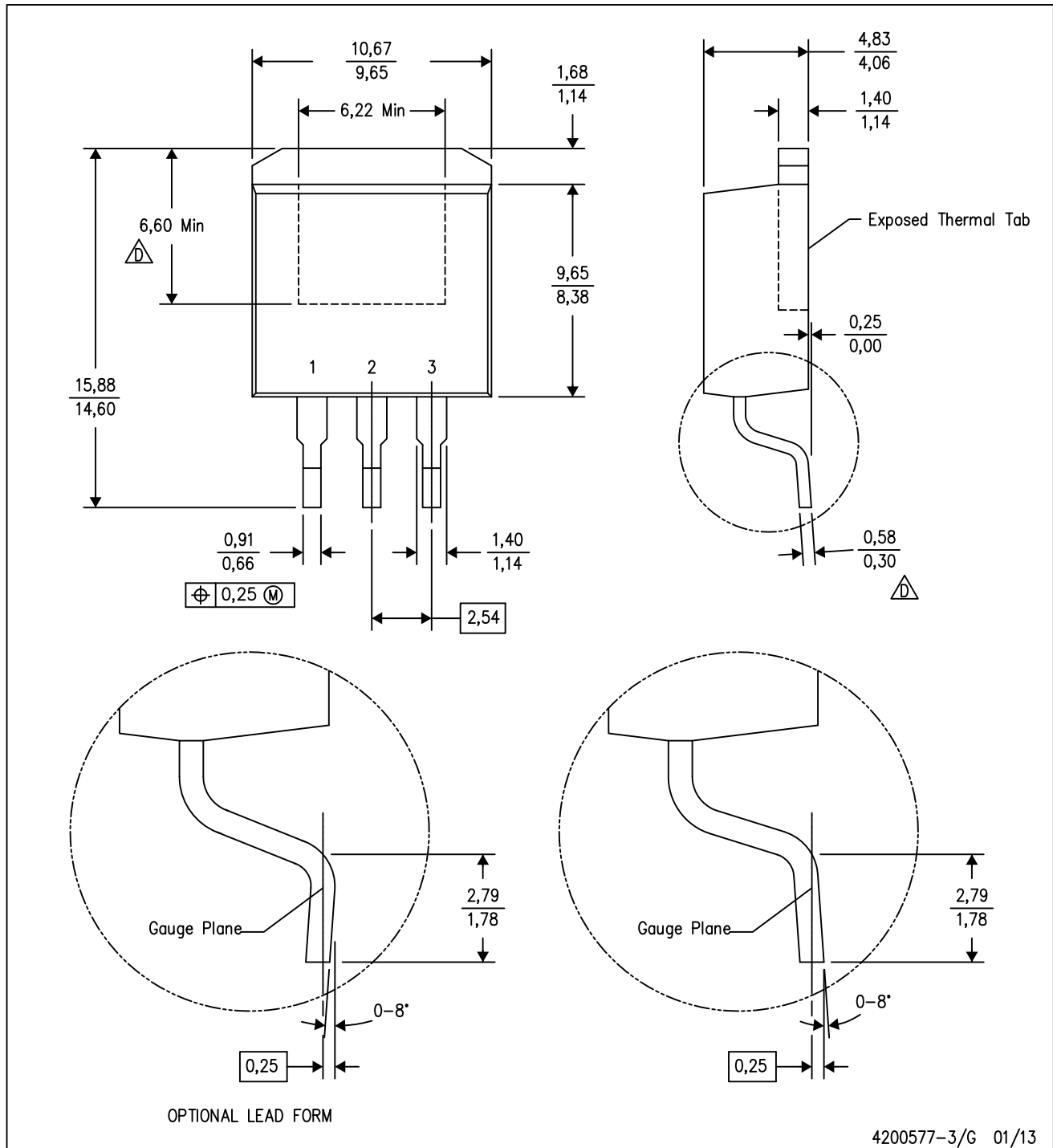

4200577-3/G 01/13

- NOTES:
- A. All linear dimensions are in millimeters.
 - B. This drawing is subject to change without notice.
 - C. Body dimensions do not include mold flash or protrusion. Mold flash or protrusion not to exceed 0.005 (0,13) per side.
-  Falls within JEDEC TO-263 variation AA, except minimum lead thickness and minimum exposed pad length.

KTT (R-PSFM-G3)

PLASTIC FLANGE-MOUNT PACKAGE

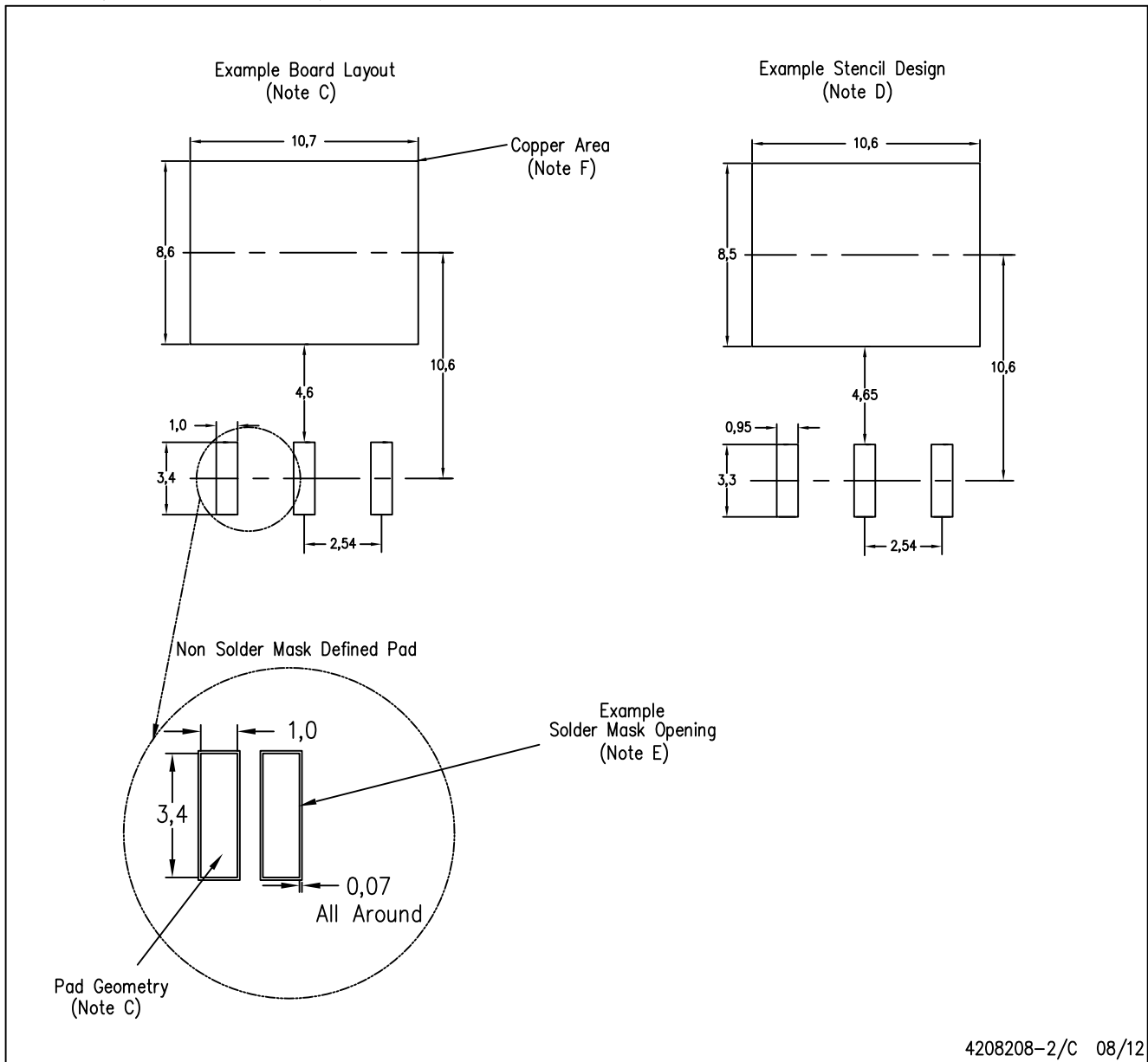

- NOTES:
- A. All linear dimensions are in millimeters.
 - B. This drawing is subject to change without notice.
 - C. Publication IPC-SM-782 is recommended for alternate designs.
 - D. Laser cutting apertures with trapezoidal walls and also rounding corners will offer better paste release. Customers should contact their board assembly site for stencil design recommendations. Refer to IPC-7525.
 - E. Customers should contact their board fabrication site for solder mask tolerances between and around signal pads.
 - F. This package is designed to be soldered to a thermal pad on the board. Refer to the Product Datasheet for specific thermal information, via requirements, and recommended thermal pad size. For thermal pad sizes larger than shown a solder mask defined pad is recommended in order to maintain the solderable pad geometry while increasing copper area.

KCS0003B

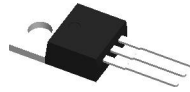

PACKAGE OUTLINE

TO-220 - 19.65 mm max height

TO-220

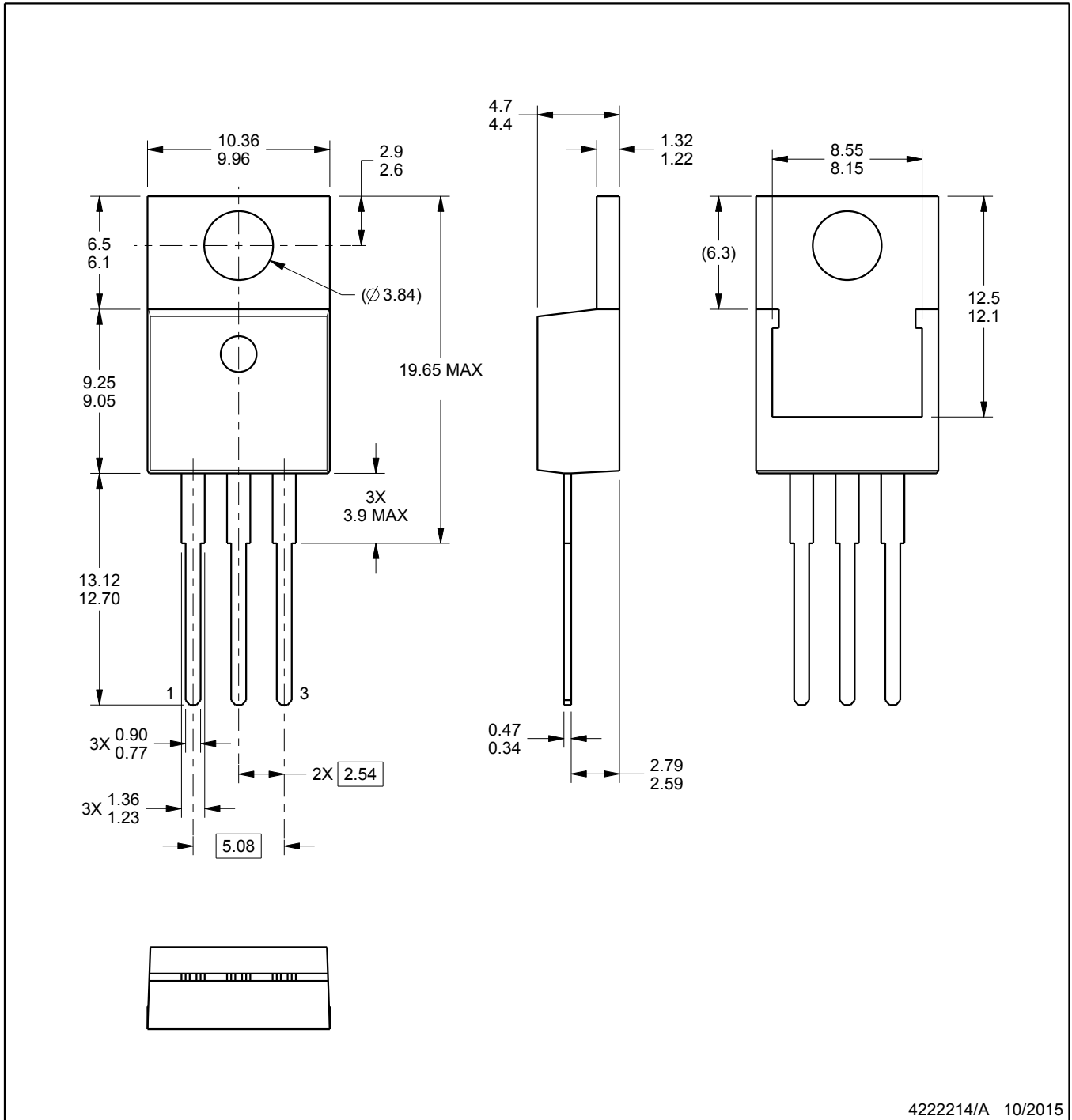

4222214/A 10/2015

NOTES:

1. All controlling linear dimensions are in inches. Dimensions in brackets are in millimeters. Any dimension in brackets or parenthesis are for reference only. Dimensioning and tolerancing per ASME Y14.5M.
2. This drawing is subject to change without notice.
3. Reference JEDEC registration TO-220.

EXAMPLE BOARD LAYOUT

KCS0003B

TO-220 - 19.65 mm max height

TO-220

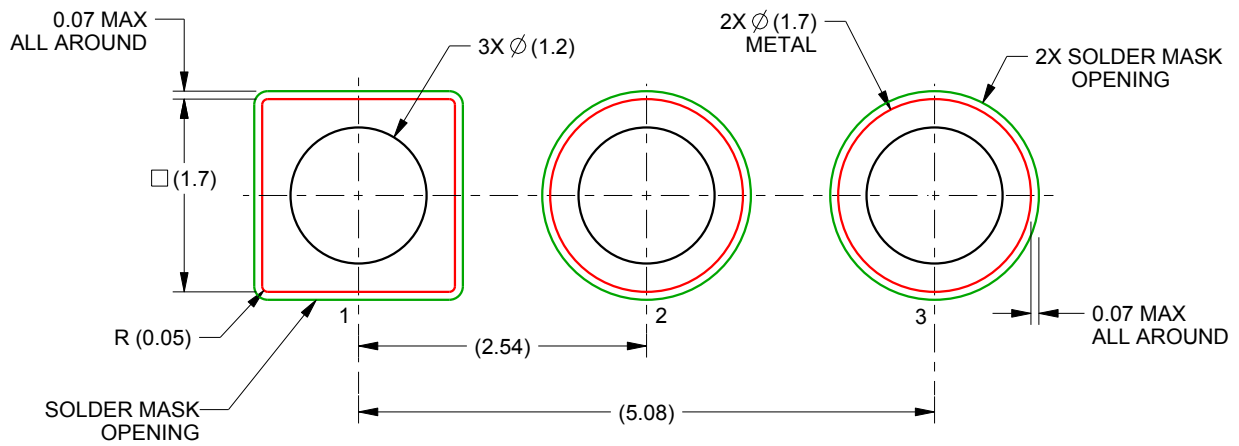

LAND PATTERN EXAMPLE
NON-SOLDER MASK DEFINED
SCALE: 15X

4222214/A 10/2015

KTE (R-PSFM-G3)

PowerFLEX™ PLASTIC FLANGE-MOUNT

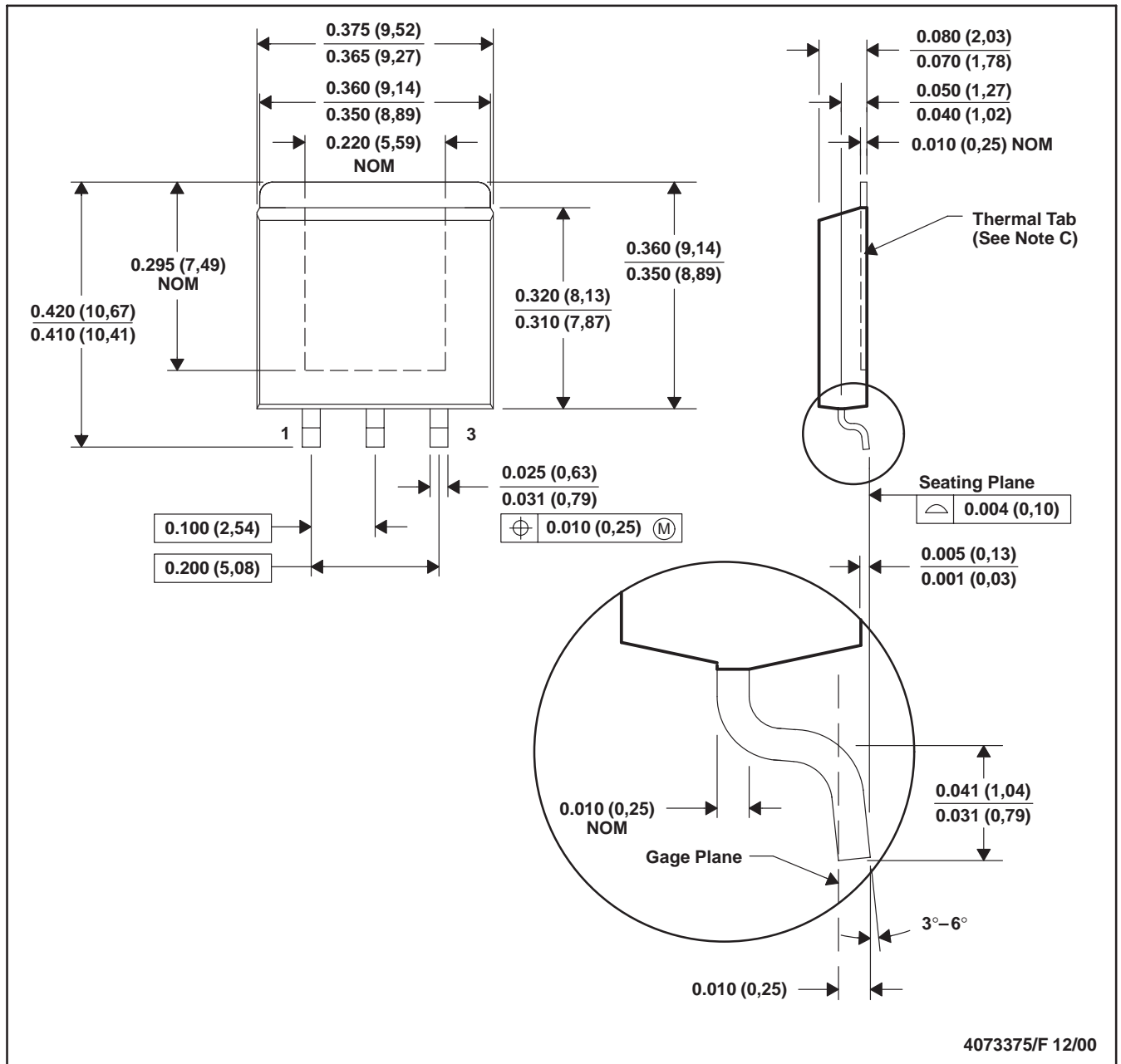

- NOTES:
- All linear dimensions are in inches (millimeters).
 - This drawing is subject to change without notice.
 - The center lead is in electrical contact with the thermal tab.
 - Dimensions do not include mold protrusions, not to exceed 0.006 (0,15).
 - Falls within JEDEC MO-169

PowerFLEX is a trademark of Texas Instruments.



IMPORTANT NOTICE FOR TI DESIGN INFORMATION AND RESOURCES

Texas Instruments Incorporated ("TI") technical, application or other design advice, services or information, including, but not limited to, reference designs and materials relating to evaluation modules, (collectively, "TI Resources") are intended to assist designers who are developing applications that incorporate TI products; by downloading, accessing or using any particular TI Resource in any way, you (individually or, if you are acting on behalf of a company, your company) agree to use it solely for this purpose and subject to the terms of this Notice.

TI's provision of TI Resources does not expand or otherwise alter TI's applicable published warranties or warranty disclaimers for TI products, and no additional obligations or liabilities arise from TI providing such TI Resources. TI reserves the right to make corrections, enhancements, improvements and other changes to its TI Resources.

You understand and agree that you remain responsible for using your independent analysis, evaluation and judgment in designing your applications and that you have full and exclusive responsibility to assure the safety of your applications and compliance of your applications (and of all TI products used in or for your applications) with all applicable regulations, laws and other applicable requirements. You represent that, with respect to your applications, you have all the necessary expertise to create and implement safeguards that (1) anticipate dangerous consequences of failures, (2) monitor failures and their consequences, and (3) lessen the likelihood of failures that might cause harm and take appropriate actions. You agree that prior to using or distributing any applications that include TI products, you will thoroughly test such applications and the functionality of such TI products as used in such applications. TI has not conducted any testing other than that specifically described in the published documentation for a particular TI Resource.

You are authorized to use, copy and modify any individual TI Resource only in connection with the development of applications that include the TI product(s) identified in such TI Resource. NO OTHER LICENSE, EXPRESS OR IMPLIED, BY ESTOPPEL OR OTHERWISE TO ANY OTHER TI INTELLECTUAL PROPERTY RIGHT, AND NO LICENSE TO ANY TECHNOLOGY OR INTELLECTUAL PROPERTY RIGHT OF TI OR ANY THIRD PARTY IS GRANTED HEREIN, including but not limited to any patent right, copyright, mask work right, or other intellectual property right relating to any combination, machine, or process in which TI products or services are used. Information regarding or referencing third-party products or services does not constitute a license to use such products or services, or a warranty or endorsement thereof. Use of TI Resources may require a license from a third party under the patents or other intellectual property of the third party, or a license from TI under the patents or other intellectual property of TI.

TI RESOURCES ARE PROVIDED "AS IS" AND WITH ALL FAULTS. TI DISCLAIMS ALL OTHER WARRANTIES OR REPRESENTATIONS, EXPRESS OR IMPLIED, REGARDING TI RESOURCES OR USE THEREOF, INCLUDING BUT NOT LIMITED TO ACCURACY OR COMPLETENESS, TITLE, ANY EPIDEMIC FAILURE WARRANTY AND ANY IMPLIED WARRANTIES OF MERCHANTABILITY, FITNESS FOR A PARTICULAR PURPOSE, AND NON-INFRINGEMENT OF ANY THIRD PARTY INTELLECTUAL PROPERTY RIGHTS.

TI SHALL NOT BE LIABLE FOR AND SHALL NOT DEFEND OR INDEMNIFY YOU AGAINST ANY CLAIM, INCLUDING BUT NOT LIMITED TO ANY INFRINGEMENT CLAIM THAT RELATES TO OR IS BASED ON ANY COMBINATION OF PRODUCTS EVEN IF DESCRIBED IN TI RESOURCES OR OTHERWISE. IN NO EVENT SHALL TI BE LIABLE FOR ANY ACTUAL, DIRECT, SPECIAL, COLLATERAL, INDIRECT, PUNITIVE, INCIDENTAL, CONSEQUENTIAL OR EXEMPLARY DAMAGES IN CONNECTION WITH OR ARISING OUT OF TI RESOURCES OR USE THEREOF, AND REGARDLESS OF WHETHER TI HAS BEEN ADVISED OF THE POSSIBILITY OF SUCH DAMAGES.

You agree to fully indemnify TI and its representatives against any damages, costs, losses, and/or liabilities arising out of your non-compliance with the terms and provisions of this Notice.

This Notice applies to TI Resources. Additional terms apply to the use and purchase of certain types of materials, TI products and services. These include; without limitation, TI's standard terms for semiconductor products (<http://www.ti.com/sc/docs/stdterms.htm>), [evaluation modules](#), and [samples](http://www.ti.com/sc/docs/sampterm.htm) (<http://www.ti.com/sc/docs/sampterm.htm>).

Mailing Address: Texas Instruments, Post Office Box 655303, Dallas, Texas 75265
Copyright © 2017, Texas Instruments Incorporated

Looking for pricing, stock, or lifecycle information?

Click below to explore more details on WIN SOURCE:

 [View UA7815CKC](#) on WIN SOURCE

 [Texas Instruments](#) Information

Optimize Your Supply Chain with WIN SOURCE Solutions

-  Global Sourcing Solution
-  Obsolete Management
-  Cost Control Management
-  Shortage Management
-  Alternative Solution
-  Excess Inventory Management