

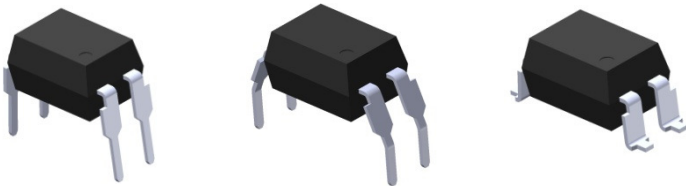

# THE DATASHEET OF EL851



## 4 PIN DIP HIGH VOLTAGE PHOTOTRANSISTOR PHOTOCOUPLER EL851 Series



Schematic

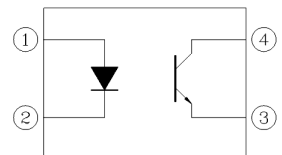

Pin Configuration

1. Anode
2. Cathode
3. Emitter
4. Collector

### Features:

- High collector- emitter voltage ( $V_{CEO}=350V$ )
- Current transfer ratio  
(CTR: 50~600% at  $I_F=5mA$ ,  $V_{CE}=5V$ )
- High isolation voltage between input and output ( $V_{iso}=5000 V rms$ )
- Compact dual-in-line package
- Pb free and RoHS compliant.
- UL approved (No. E214129)
- VDE approved (No. 132249)
- SEMKO approved
- NEMKO approved
- DEMKO approved
- FIMKO approved

### Description

The EL851 series devices consist an infrared emitting diodes, optically coupled to a phototransistor detector.

The devices are in a 4-pin DIP package and available in wide-lead spacing and SMD option.

### Applications

- Telephone line interface
- Interface to power supply circuit
- Controller for SSRs. DC motor
- Programmable Controllers

**Absolute Maximum Ratings (Ta=25°C)**

|        | Parameter                        | Symbol    | Rating     | Unit  |
|--------|----------------------------------|-----------|------------|-------|
| Input  | Forward current                  | $I_F$     | 60         | mA    |
|        | Peak forward current (1μs pulse) | $I_{FM}$  | 1          | A     |
|        | Reverse voltage                  | $V_R$     | 6          | V     |
|        | Power dissipation                | $P_D$     | 100        | mW    |
| Output | Collector power dissipation      | $P_C$     | 150        | mW    |
|        | Collector-Emitter voltage        | $V_{CEO}$ | 350        | V     |
|        | Collector Current                | $I_C$     | 50         | mA    |
|        | Emitter-Collector voltage        | $V_{ECO}$ | 7          | V     |
|        | Total Power Dissipation          | $P_{TOT}$ | 200        | mW    |
|        | Isolation Voltage*1              | $V_{ISO}$ | 5000       | V rms |
|        | Operating Temperature            | $T_{OPR}$ | -55 to 100 | °C    |
|        | Storage Temperature              | $T_{STG}$ | -55 to 125 | °C    |
|        | Soldering Temperature*2          | $T_{SOL}$ | 260        | °C    |

Notes:

\*1 AC for 1 minute, R.H.= 40 ~ 60% R.H. In this test, pins 1, 2 are shorted together, and pins 3, 4 are shorted together.

\*2 For 10 seconds

**Electro-Optical Characteristics (Ta=25°C unless specified otherwise)**

**Input**

| Parameter         | Symbol   | Min. | Typ. | Max. | Unit          | Condition                |
|-------------------|----------|------|------|------|---------------|--------------------------|
| Forward Voltage   | $V_F$    | -    | 1.2  | 1.4  | V             | $I_F = 10\text{mA}$      |
| Reverse Current   | $I_R$    | -    | -    | 10   | $\mu\text{A}$ | $V_R = 5\text{V}$        |
| Input capacitance | $C_{in}$ | -    | 30   | 250  | pF            | $V = 0, f = 1\text{kHz}$ |

**Output**

| Parameter                           | Symbol     | Min | Typ. | Max. | Unit | Condition                             |
|-------------------------------------|------------|-----|------|------|------|---------------------------------------|
| Collector-Emitter dark current      | $I_{CEO}$  | -   | -    | 100  | nA   | $V_{CE} = 200\text{V}$                |
| Collector-Emitter breakdown voltage | $BV_{CEO}$ | 350 | -    | -    | V    | $I_C = 0.1\text{mA}$                  |
| Emitter-Collector breakdown voltage | $BV_{ECO}$ | 7   | -    | -    | V    | $I_E = 0.1\text{mA}$                  |
| Collector-Emitter capacitance       | $C_{CE}$   | -   | 10   | -    | pF   | $V_{CE} = 0\text{V}, f = 1\text{MHz}$ |

**Transfer Characteristics**

| Parameter                            | Symbol        | Min       | Typ. | Max. | Unit          | Condition   |
|--------------------------------------|---------------|-----------|------|------|---------------|---|
| Current Transfer Ratio               | CTR           | 50        | -    | 600  | %             | $I_F = 5\text{mA}, V_{CE} = 5\text{V}$                  |
| Collector-emitter saturation voltage | $V_{CE(sat)}$ | -         | -    | 0.4  | V             | $I_F = 20\text{mA}, I_C = 1\text{mA}$                   |
| Isolation resistance                 | $R_{IO}$      | $10^{11}$ | -    | -    | $\Omega$      | $V_{IO} = 500\text{Vdc}$                                |
| Input-output capacitance             | $C_{IO}$      | -         | 0.6  | -    | pF            | $V_{IO} = 0, f = 1\text{MHz}$                           |
| Rise time                            | $t_r$         | -         | 4    | 18   | $\mu\text{s}$ | $V_{CE} = 2\text{V}, I_C = 2\text{mA}, R_L = 100\Omega$ |
| Fall time                            | $t_f$         | -         | 5    | 18   | $\mu\text{s}$ |   |

\* Typical values at  $T_a = 25^\circ\text{C}$

Typical Electro-Optical Characteristics Curves

Figure 1. Forward Current vs Forward Voltage

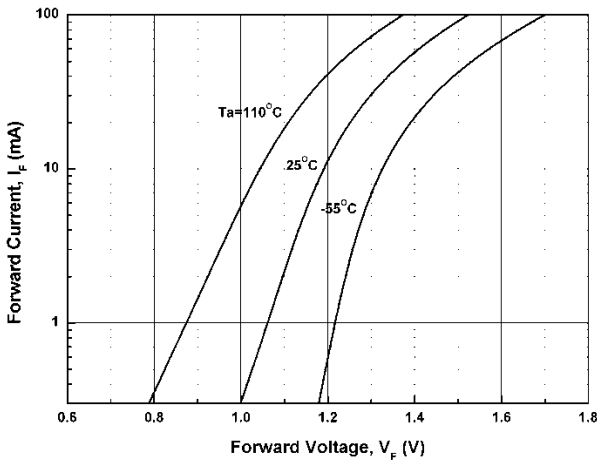

Figure 2. Current Transfer Ratio vs Forward Current

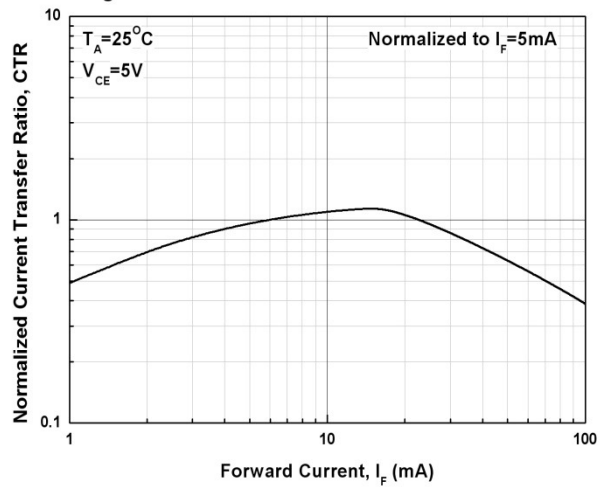

Figure 3. Collector Current vs Collector-emitter Voltage

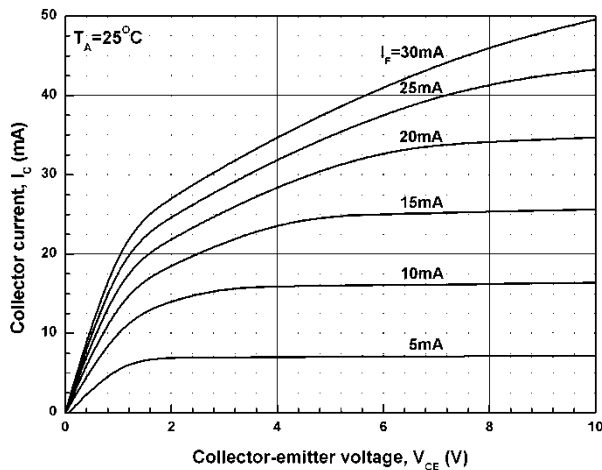

Figure 4. Relative Current Transfer Ratio vs Ambient Temperature

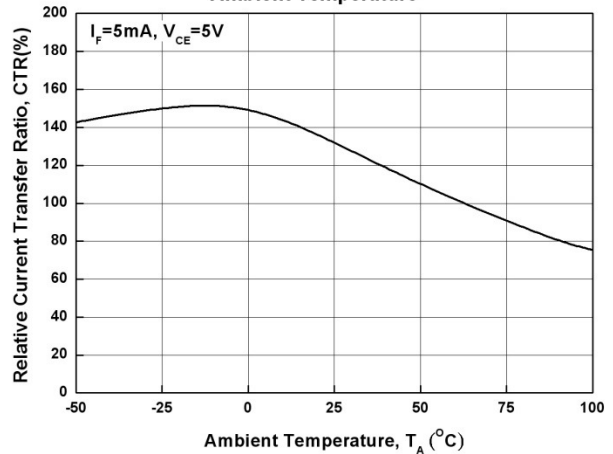

Figure 5. Collector-emitter Saturation Voltage vs Ambient Temperature

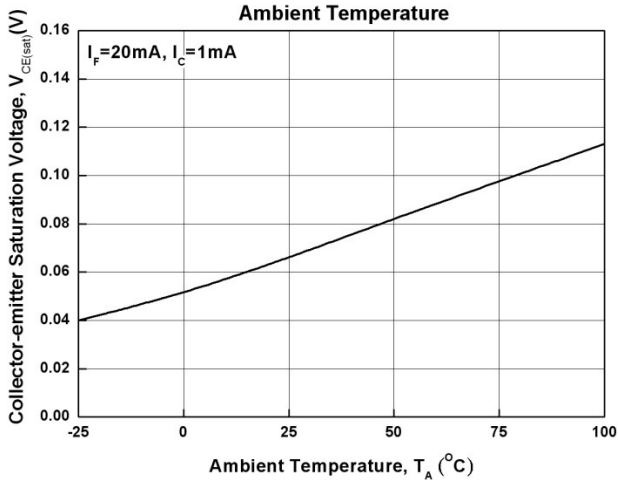

Figure 6. Dark Current vs Ambient Temperature

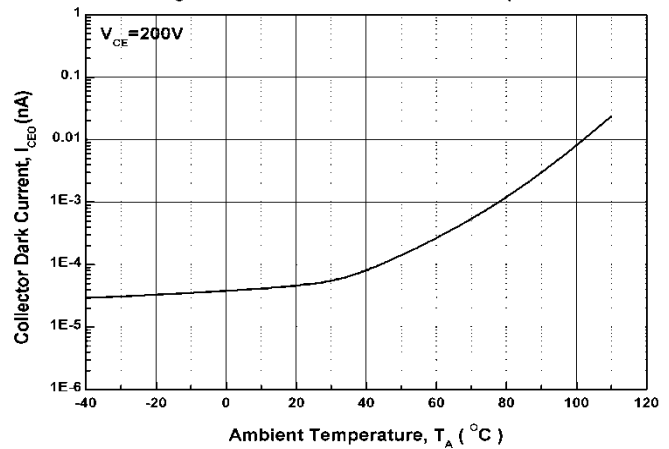

Figure 7. Switching Time vs. Load Resistance

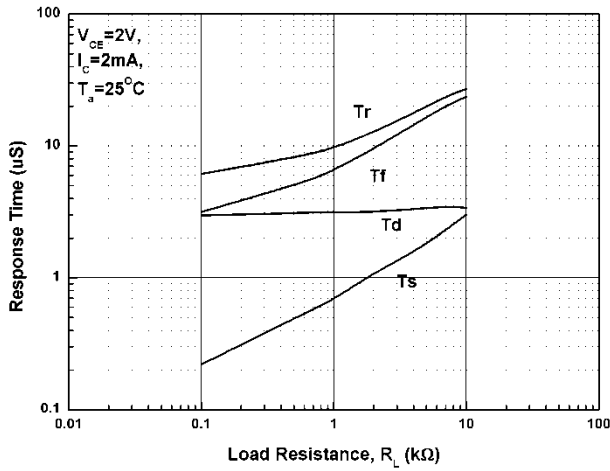

Figure 8. Collector-emitter Saturation Voltage vs Forward Current

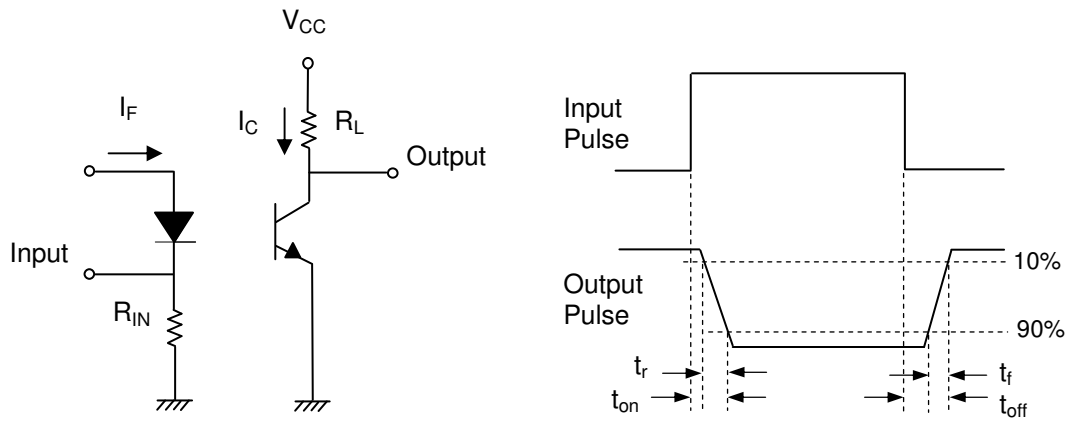
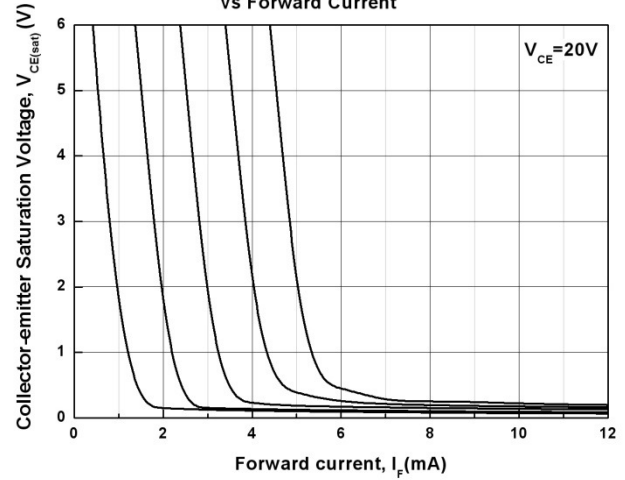

Figure 9. Switching Time Test Circuit & Waveforms

## Order Information

### Part Number

**EL851X(Z)-V**

### Note

- X = Lead form option (S, S1, M or none)
- Z = Tape and reel option (TA, TB, TU, TD or none).
- V = VDE safety (optional).

| Option  | Description   | Packing quantity    |
|---------|---|---------------------|
| None    | Standard DIP-4  | 100 units per tube  |
| M       | Wide lead bend (0.4 inch spacing)                             | 100 units per tube  |
| S (TA)  | Surface mount lead form + TA tape & reel option               | 1000 units per reel |
| S (TB)  | Surface mount lead form + TB tape & reel option               | 1000 units per reel |
| S1 (TA) | Surface mount lead form (low profile) + TA tape & reel option | 1000 units per reel |
| S1 (TB) | Surface mount lead form (low profile) + TB tape & reel option | 1000 units per reel |
| S (TU)  | Surface mount lead form + TU tape & reel option               | 1500 units per reel |
| S (TD)  | Surface mount lead form + TD tape & reel option               | 1500 units per reel |
| S1 (TU) | Surface mount lead form (low profile) + TU tape & reel option | 1500 units per reel |
| S1 (TD) | Surface mount lead form (low profile) + TD tape & reel option | 1500 units per reel |

Package Dimension (Dimensions in mm)

Standard DIP Type

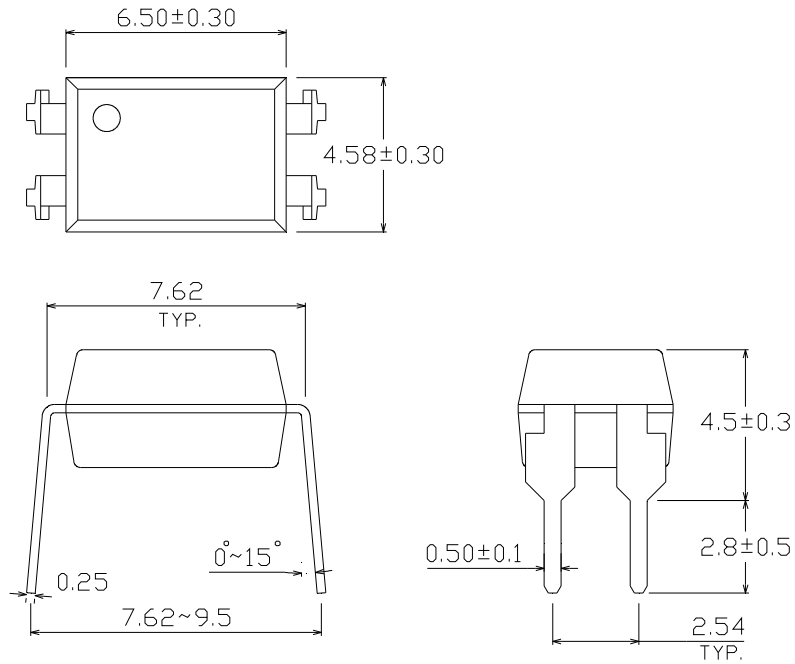

Option M Type

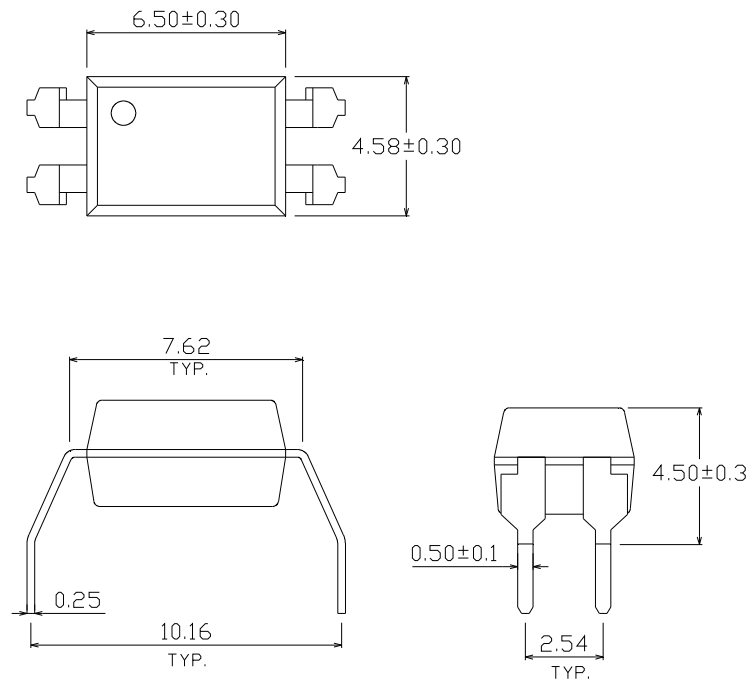

Option S Type

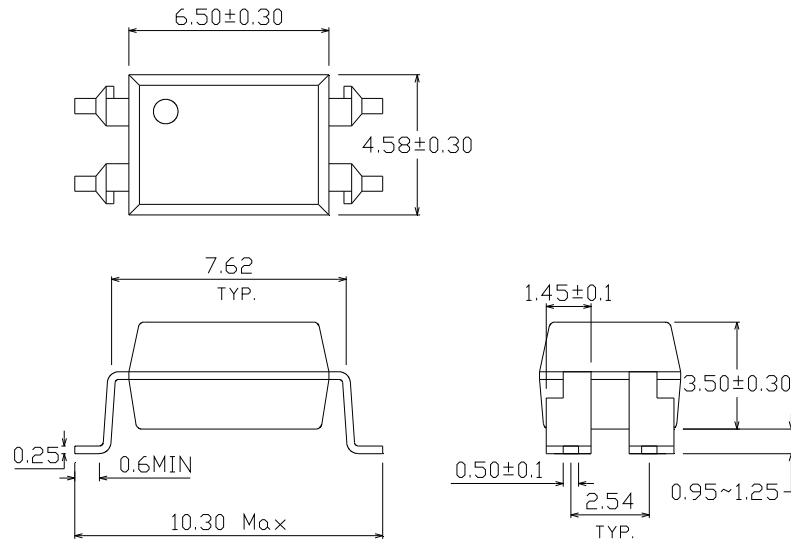

Option S1 Type

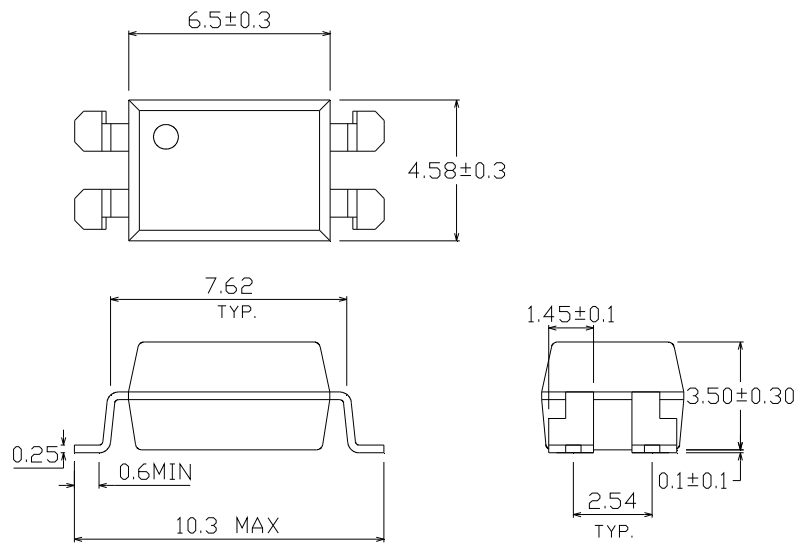

### Recommended pad layout for surface mount leadform

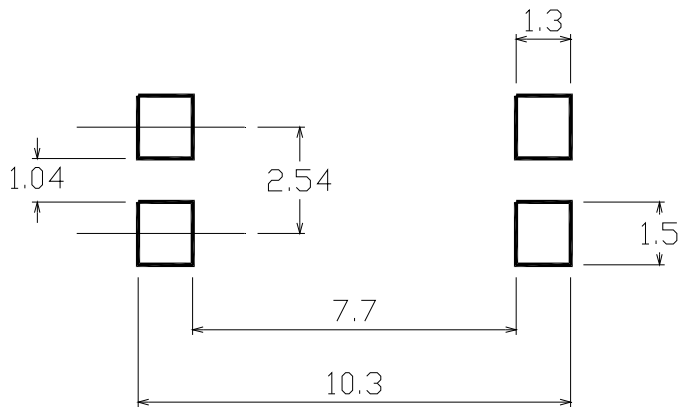

### Device Marking



### Notes

- EL denotes EVERLIGHT
- 851 denotes Device Number
- Y denotes 1 digit Year code
- WW denotes 2 digit Week code
- V denotes VDE (optional)

**Tape & Reel Packing Specifications**

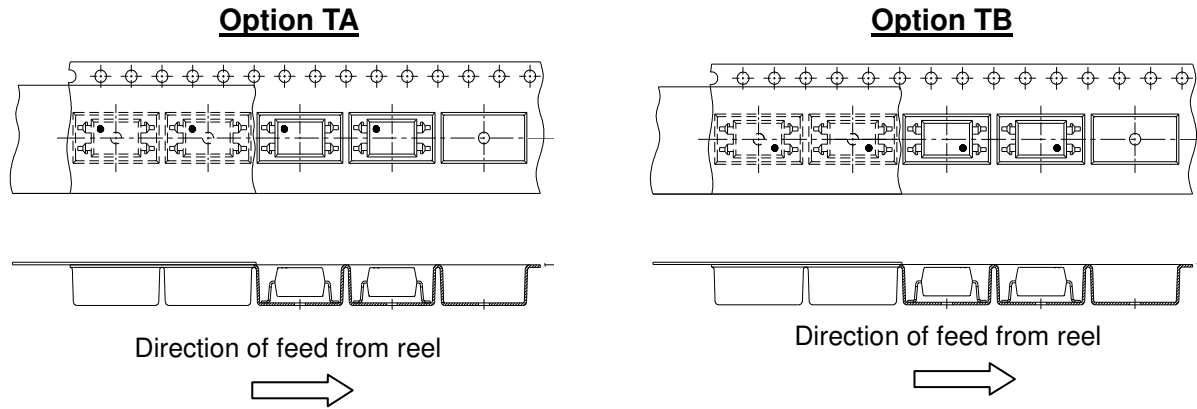

**Tape dimensions**

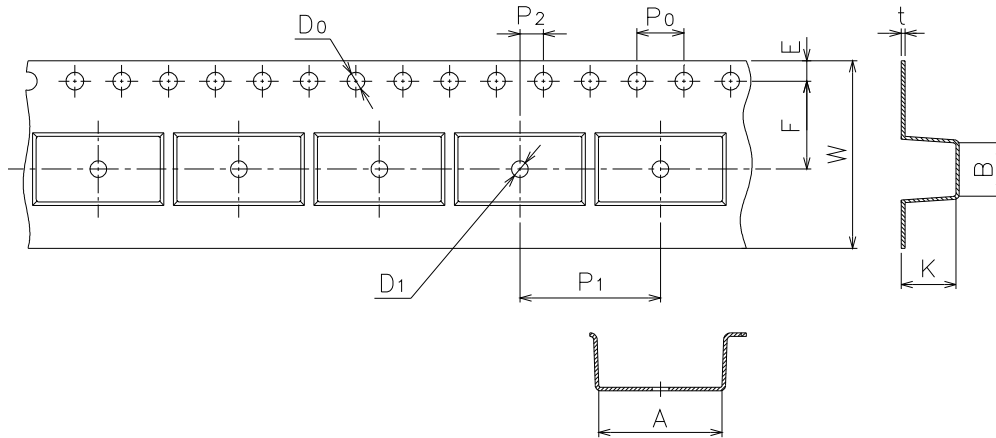

|                      |           |           |           |           |          |          |
|----------------------|-----------|-----------|-----------|-----------|----------|----------|
| Dimension No.        | <b>A</b>  | <b>B</b>  | <b>Do</b> | <b>D1</b> | <b>E</b> | <b>F</b> |
| Dimension (mm)<br>S  | 10.5±0.1  | 4.65±0.1  | 1.5±0.1   | 1.50±0.1  | 1.75±0.1 | 7.5±0.1  |
| Dimension (mm)<br>S1 | 10.5±0.1  | 4.65±0.1  | 1.5±0.1   | 1.50±0.1  | 1.75±0.1 | 7.5±0.1  |
| Dimension No.        | <b>Po</b> | <b>P1</b> | <b>P2</b> | <b>t</b>  | <b>W</b> | <b>K</b> |
| Dimension (mm)<br>S  | 4.0±0.1   | 12.0±0.1  | 2.0±0.1   | 0.4±0.1   | 16.0±0.3 | 5.05±0.1 |
| Dimension (mm)<br>S1 | 4.0±0.1   | 12.0±0.1  | 2.0±0.1   | 0.4±0.1   | 16.0±0.3 | 4.75±0.1 |

**Tape & Reel Packing Specifications**

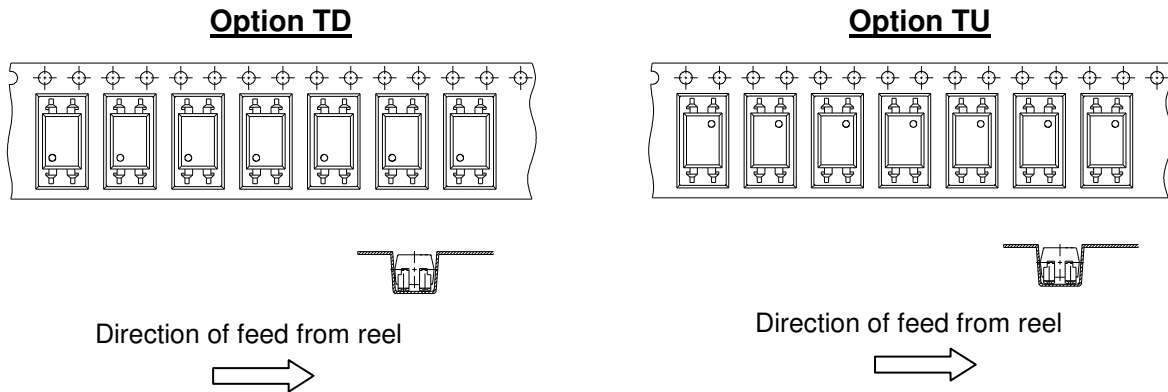

**Tape dimensions**

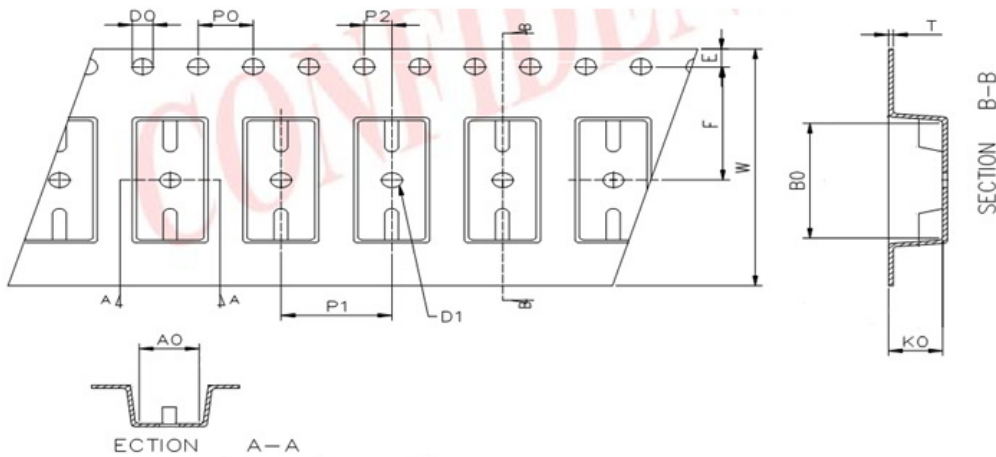

|                |           |           |           |           |           |           |
|----------------|-----------|-----------|-----------|-----------|-----------|-----------|
| Dimension No.  | <b>Ao</b> | <b>Bo</b> | <b>Do</b> | <b>D1</b> | <b>E</b>  | <b>F</b>  |
| Dimension (mm) | 4.90±0.1  | 10.40±0.1 | 1.5±0.1   | 1.50±0.1  | 1.75±0.1  | 7.50±0.1  |
| Dimension No.  | <b>Po</b> | <b>P1</b> | <b>P2</b> | <b>t</b>  | <b>W</b>  | <b>Ko</b> |
| Dimension(mm)  | 4.00±0.1  | 8.00±0.   | 2.00±0.1  | 0.40±0.1  | 16.00±0.3 | 4.60±0.1  |

## Precautions for Use

### 1. Soldering Condition

#### 1.1 (A) Maximum Body Case Temperature Profile for evaluation of Reflow Profile

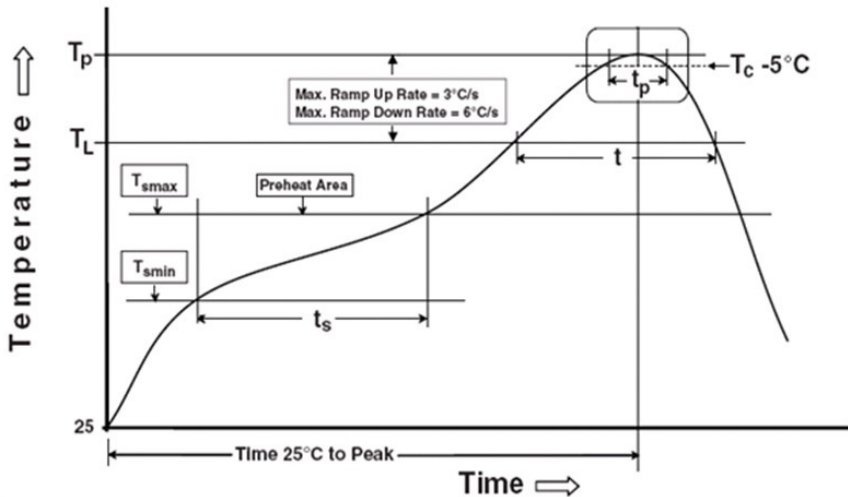

Note:

Reference: IPC/JEDEC J-STD-020D

#### Preheat

|  |                 |
|--|-----------------|
| Temperature min ( $T_{smin}$ )               | 150 °C          |
| Temperature max ( $T_{smax}$ )               | 200 °C          |
| Time ( $T_{smin}$ to $T_{smax}$ ) ( $t_s$ )  | 60-120 seconds  |
| Average ramp-up rate ( $T_{smax}$ to $T_p$ ) | 3 °C/second max |

#### Other

|  |                   |
|--|-------------------|
| Liquidus Temperature ( $T_L$ )                                       | 217 °C            |
| Time above Liquidus Temperature ( $t_L$ )                            | 60-100 sec        |
| Peak Temperature ( $T_p$ )   | 260 °C            |
| Time within 5 °C of Actual Peak Temperature: $T_p - 5^\circ\text{C}$ | 30 s              |
| Ramp- Down Rate from Peak Temperature                                | 6 °C /second max. |
| Time 25 °C to peak temperature                                       | 8 minutes max.    |
| Reflow times   | 3 times           |

## **DISCLAIMER**

1. Above specification may be changed without notice. EVERLIGHT will reserve authority on material change for above specification.
2. When using this product, please observe the absolute maximum ratings and the instructions for using outlined in these specification sheets. EVERLIGHT assumes no responsibility for any damage resulting from use of the product which does not comply with the absolute maximum ratings and the instructions included in these specification sheets.
3. These specification sheets include materials protected under copyright of EVERLIGHT corporation. Please don't reproduce or cause anyone to reproduce them without EVERLIGHT's consent.

## Looking for pricing, stock, or lifecycle information?

Click below to explore more details on WIN SOURCE:

- [View EL851 on WIN SOURCE](#)
- [Everlight Electronics Co Ltd Information](#)

## Optimize Your Supply Chain with WIN SOURCE Solutions

- ✓ Global Sourcing Solution
- ✓ Obsolete Management
- ✓ Cost Control Management
- ✓ Shortage Management
- ✓ Alternative Solution
- ✓ Excess Inventory Management