



**THE DATASHEET OF
SN75LVDS179DR**



SN75LVDS179, SN75LVDS180, SN75LVDS050, SN75LVDS051 HIGH-SPEED DIFFERENTIAL LINE DRIVERS AND RECEIVERS

SLLS361A – JUNE 1999 – REVISED MARCH 2000

- Meets or Exceeds the Requirements of ANSI TIA/EIA-644-1995 Standard
- Signaling Rates up to 155 Mbps
- Operates From a Single 3.3-V Supply
- Low-Voltage Differential Signaling With Typical Output Voltages of 350 mV and a 100 Ω Load
- LVTTTL Input Levels are 5 V Tolerant
- Driver is High Impedance When Disabled or With $V_{CC} < 1.5$ V
- Receiver has Open-Circuit Fail Safe
- Surface-Mount Packaging – D Package (SOIC)
- Characterized For Operation From 0°C to 70°C

description

The SN75LVDS179, SN75LVDS180, SN75LVDS050, and SN75LVDS051 are differential line drivers and receivers that use low-voltage differential signaling (LVDS) to achieve signaling rates as high as 155 Mbps. The TIA/EIA-644 standard compliant electrical interface provides a minimum differential output voltage magnitude of 247 mV into a 100 Ω load and receipt of 100 mV signals with up to 1 V of ground potential difference between a transmitter and receiver.

The intended application of this device and signaling technique is for point-to-point baseband data transmission over controlled impedance media of approximately 100 Ω characteristic impedance. The transmission media may be printed-circuit board traces, backplanes, or cables. (Note: The ultimate rate and distance of data transfer is dependent upon the attenuation characteristics of the media, the noise coupling to the environment, and other application specific characteristics).

The SN75LVDS179, SN75LVDS180, SN75LVDS050, and SN75LVDS051 are characterized for operation from 0°C to 70°C.

SN75LVDS179D (Marked as DS179 or 7LS179)
(TOP VIEW)

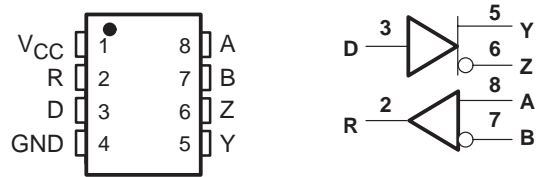

SN75LVDS180D (Marked as 7LVDS180)
(TOP VIEW)

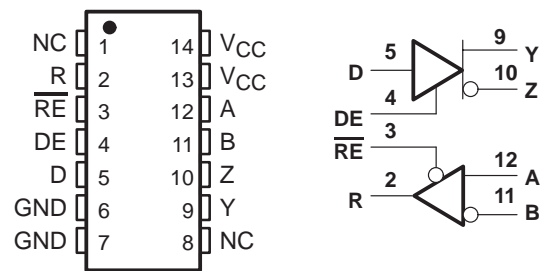

SN75LVDS050D (Marked as 75LVDS050)
(TOP VIEW)

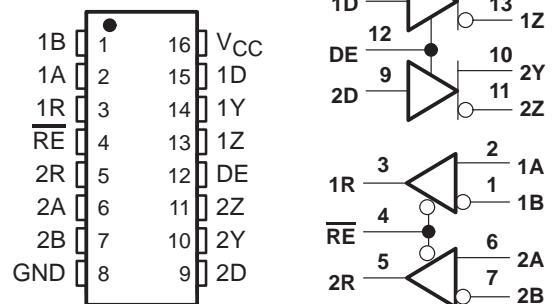

SN75LVDS051D (Marked as 75LVDS051)
(TOP VIEW)

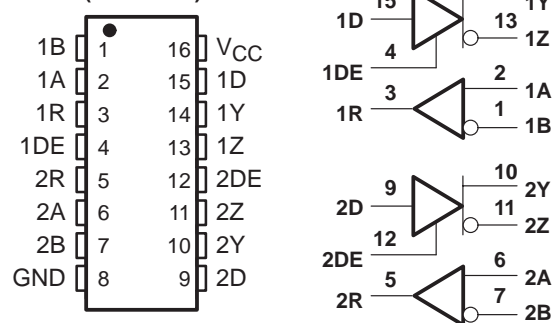

Please be aware that an important notice concerning availability, standard warranty, and use in critical applications of Texas Instruments semiconductor products and disclaimers thereto appears at the end of this data sheet.

PRODUCTION DATA information is current as of publication date. Products conform to specifications per the terms of Texas Instruments standard warranty. Production processing does not necessarily include testing of all parameters.

**TEXAS
INSTRUMENTS**

POST OFFICE BOX 655303 • DALLAS, TEXAS 75265

Copyright © 2000, Texas Instruments Incorporated

SN75LVDS179, SN75LVDS180, SN75LVDS050, SN75LVDS051 HIGH-SPEED DIFFERENTIAL LINE DRIVERS AND RECEIVERS

SLLS361A – JUNE 1999 – REVISED MARCH 2000

Function Tables

SN75LVDS179 RECEIVER

INPUTS	OUTPUT
$V_{ID} = V_A - V_B$	R
$V_{ID} \geq 100 \text{ mV}$	H
$-100 \text{ mV} < V_{ID} < 100 \text{ mV}$?
$V_{ID} \leq -100 \text{ mV}$	L
Open	H

H = high level, L = low level, ? = indeterminate

SN75LVDS179 DRIVER

INPUT	OUTPUTS	
D	Y	Z
L	L	H
H	H	L
Open	L	H

H = high level, L = low level

SN75LVDS180, SN75LVDS050, and SN75LVDS051 RECEIVER

INPUTS		OUTPUT
$V_{ID} = V_A - V_B$	\overline{RE}	R
$V_{ID} \geq 100 \text{ mV}$	L	H
$-100 \text{ mV} < V_{ID} < 100 \text{ mV}$	L	?
$V_{ID} \leq -100 \text{ mV}$	L	L
Open	L	H
X	H	Z

H = high level, L = low level, Z = high impedance, X = don't care

SN75LVDS180, SN75LVDS050, and SN75LVDS051 DRIVER

INPUTS		OUTPUTS	
D	DE	Y	Z
L	H	L	H
H	H	H	L
Open	H	L	H
X	L	Z	Z

H = high level, L = low level, Z = high impedance, X = don't care

SN75LVDS179, SN75LVDS180, SN75LVDS050, SN75LVDS051 HIGH-SPEED DIFFERENTIAL LINE DRIVERS AND RECEIVERS

SLLS361A – JUNE 1999 – REVISED MARCH 2000

equivalent input and output schematic diagrams

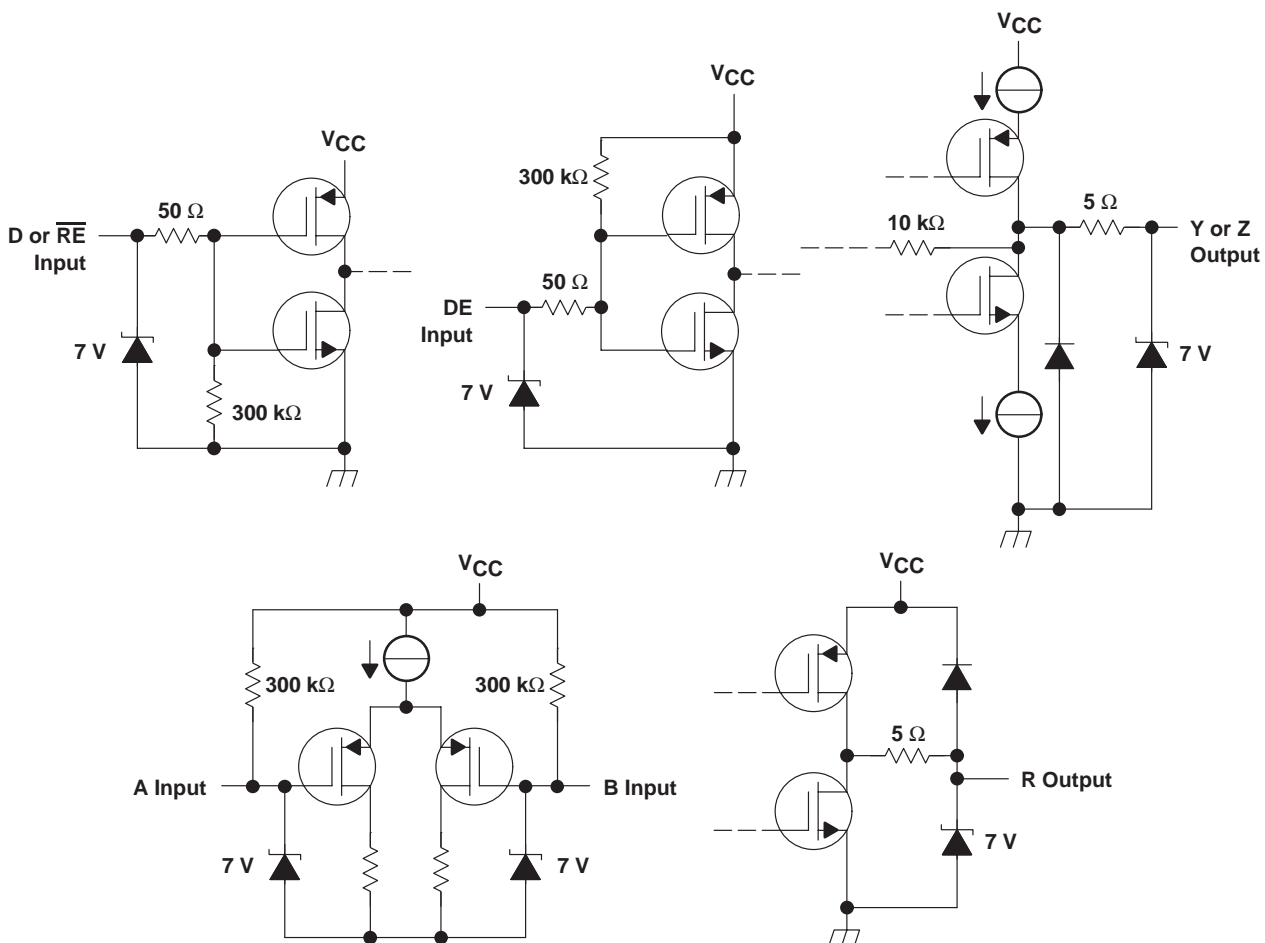

SN75LVDS179, SN75LVDS180, SN75LVDS050, SN75LVDS051 HIGH-SPEED DIFFERENTIAL LINE DRIVERS AND RECEIVERS

SLLS361A – JUNE 1999 – REVISED MARCH 2000

absolute maximum ratings over operating free-air temperature (unless otherwise noted)†

Supply voltage range, V_{CC} (see Note 1)	–0.5 V to 4 V
Voltage range (D, R, DE, \overline{RE})	–0.5 V to 6 V
Continuous power dissipation	see dissipation rating table
Storage temperature range	–65°C to 150°C
Lead temperature 1,6 mm (1/16 inch) from case for 10 seconds	250°C

† Stresses beyond those listed under “absolute maximum ratings” may cause permanent damage to the device. These are stress ratings only, and functional operation of the device at these or any other conditions beyond those indicated under “recommended operating conditions” is not implied. Exposure to absolute-maximum-rated conditions for extended periods may affect device reliability.

- NOTES: 1. All voltage values, except differential I/O bus voltages are with respect to network ground terminal.
2. Tested in accordance with MIL-STD-883C Method 3015.7.

DISSIPATION RATING TABLE

PACKAGE	$T_A \leq 25^\circ\text{C}$ POWER RATING	DERATING FACTOR ABOVE $T_A = 25^\circ\text{C}$ †	$T_A = 70^\circ\text{C}$ POWER RATING
D8	725 mW	5.8 mW/°C	464 mW
D14 or D16	950 mW	7.8 mW/°C	608 mW

† This is the inverse of the junction-to-ambient thermal resistance when board-mounted and with no air flow.

recommended operating conditions

	MIN	NOM	MAX	UNIT
Supply voltage, V_{CC}	3	3.3	3.6	V
High-level input voltage, V_{IH}	2			V
Low-level input voltage, V_{IL}			0.8	V
Magnitude of differential input voltage, $ V_{ID} $	0.1		0.6	V
Common-mode input voltage, V_{IC} (see Figure 6)	$\frac{ V_{ID} }{2}$	2.4	$\frac{ V_{ID} }{2}$	V
		$V_{CC}-0.8$		
Operating free-air temperature, T_A	0		70	°C



SN75LVDS179, SN75LVDS180, SN75LVDS050, SN75LVDS051 HIGH-SPEED DIFFERENTIAL LINE DRIVERS AND RECEIVERS

SLLS361A – JUNE 1999 – REVISED MARCH 2000

device electrical characteristics over recommended operating conditions (unless otherwise noted)

PARAMETER		TEST CONDITIONS	MIN	TYP†	MAX	UNIT	
I _{CC}	Supply current	SN75LVDS179	No receiver load, driver R _L = 100 Ω		9	12	mA
		SN75LVDS180	Driver and receiver enabled, No receiver load, Driver R _L = 100 Ω		9	12	
			Driver enabled, receiver disabled, R _L = 100 Ω		5	7	
			Driver disabled, receiver enabled, No load		1.5	2	
			Disabled		0.5	1	
		SN75LVDS050	Drivers and receivers enabled, no receiver loads, Driver R _L = 100 Ω		12	20	mA
			Drivers enabled, receivers disabled, R _L = 100 Ω		10	16	
			Drivers disabled, receivers enabled, no loads		3	6	
			Disabled		0.5	1	
		SN75LVDS051	Drivers enabled, no receiver loads, driver R _L = 100 Ω		12	20	mA
Drivers disabled, No loads			3	6			

† All typical values are at 25°C and with a 3.3-V supply.

driver electrical characteristics over recommended operating conditions (unless otherwise noted)

PARAMETER		TEST CONDITIONS	MIN	TYP	MAX	UNIT
V _{OD}	Differential output voltage magnitude	R _L = 100Ω, See Figure 1 and Figure 2	247	340	454	mV
Δ V _{OD}	Change in differential output voltage magnitude between logic states		-50		50	
V _{OC(SS)}	Steady-state common-mode output voltage	See Figure 3	1.125	1.2	1.375	V
ΔV _{OC(SS)}	Change in steady-state common-mode output voltage between logic states		-50		50	mV
V _{OC(PP)}	Peak-to-peak common-mode output voltage		50		150	mV
I _{IH}	High-level input current	DE	V _{IH} = 5 V	-0.5	-20	μA
		D		2	20	
I _{IL}	Low-level input current	DE	V _{IL} = 0.8 V	-0.5	-10	μA
		D		2	10	
I _{OS}	Short-circuit output current	V _{OY} or V _{OZ} = 0 V		3	10	mA
		V _{OD} = 0 V		3	10	
I _{OZ}	High-impedance output current	V _{OD} = 600 mV			±1	μA
		V _O = 0 V or V _{CC}			±1	
I _{O(OFF)}	Power-off output current	V _{CC} = 0 V, V _O = 3.6 V			±1	μA
C _{IN}	Input capacitance			3		pF

SN75LVDS179, SN75LVDS180, SN75LVDS050, SN75LVDS051 HIGH-SPEED DIFFERENTIAL LINE DRIVERS AND RECEIVERS

SLLS361A – JUNE 1999 – REVISED MARCH 2000

receiver electrical characteristics over recommended operating conditions (unless otherwise noted)

PARAMETER	TEST CONDITIONS	MIN	TYP†	MAX	UNIT
V _{ITH+} Positive-going differential input voltage threshold	See Figure 5 and Table 1			100	mV
V _{ITH-} Negative-going differential input voltage threshold				-100	
V _{OH} High-level output voltage	I _{OH} = -8 mA	2.4			V
V _{OL} Low-level output voltage	I _{OL} = 8 mA			0.4	V
I _I Input current (A or B inputs)	V _I = 0	-2	-11	-20	μA
	V _I = 2.4 V	-1.2	-3		
I _{I(OFF)} Power-off input current (A or B inputs)	V _{CC} = 0			±20	μA
I _{IH} High-level input current (enables)	V _{IH} = 5 V			±10	μA
I _{IL} Low-level input current (enables)	V _{IL} = 0.8 V			±10	μA
I _{OZ} High-impedance output current	V _O = 0 or 5 V			±10	μA
C _I Input capacitance			5		pF

† All typical values are at 25°C and with a 3.3-V supply.

driver switching characteristics over recommended operating conditions (unless otherwise noted)

PARAMETER	TEST CONDITIONS	MIN	TYP†	MAX	UNIT	
t _{PLH} Propagation delay time, low-to-high-level output	R _L = 100Ω, C _L = 10 pF, See Figure 6			6	ns	
t _{PHL} Propagation delay time, high-to-low-level output				6	ns	
t _r Differential output signal rise time			0.8	1.2	ns	
t _f Differential output signal fall time			0.8	1.2	ns	
t _{sk(p)} Pulse skew ((t _{pHL} - t _{pLH}))‡					0.6	ps
t _{sk(o)} Channel-to-channel output skew§					0.6	ps
t _{sk(pp)} Part-to-part skew¶					1	ps
t _{PZH} Propagation delay time, high-impedance-to-high-level output	See Figure 7			25	ns	
t _{PZL} Propagation delay time, high-impedance-to-low-level output				25	ns	
t _{PHZ} Propagation delay time, high-level-to-high-impedance output				25	ns	
t _{pLZ} Propagation delay time, low-level-to-high-impedance output				25	ns	

† All typical values are at 25°C and with a 3.3-V supply.

‡ t_{sk(p)} is the magnitude of the time difference between the high-to-low and low-to-high propagation delay times at an output

§ t_{sk(o)} is the magnitude of the time difference between the outputs of a single device with all of their inputs connected together.

¶ t_{sk(pp)} is the magnitude of the difference in propagation delay times between any specified terminals of two devices when both devices operate with the same supply voltages, same temperature, and have identical packages and test circuits.



SN75LVDS179, SN75LVDS180, SN75LVDS050, SN75LVDS051 HIGH-SPEED DIFFERENTIAL LINE DRIVERS AND RECEIVERS

SLLS361A – JUNE 1999 – REVISED MARCH 2000

receiver switching characteristics over recommended operating conditions (unless otherwise noted)

PARAMETER		TEST CONDITIONS	MIN	TYP†	MAX	UNIT
t _{PLH}	Propagation delay time, low-to-high-level output	C _L = 10 pF, See Figure 6		2.1	6	ns
t _{PHL}	Propagation delay time, high-to-low-level output			2.1	6	ns
t _r	Output signal rise time			0.6	1.5	ns
t _f	Output signal fall time			0.7	1.5	ns
t _{sk(p)}	Pulse skew (t _{PHL} – t _{PLH})‡				0.6	ns
t _{sk(o)}	Channel-to-channel output skew§				0.6	ns
t _{sk(pp)}	Part-to-part skew¶				1	ns
t _{PZH}	Propagation delay time, high-level-to-high-impedance output	See Figure 7			25	ns
t _{PZL}	Propagation delay time, low-level-to-low-impedance output				25	ns
t _{PHZ}	Propagation delay time, high-impedance-to-high-level output				25	ns
t _{PLZ}	Propagation delay time, low-impedance-to-high-level output				25	ns

† All typical values are at 25°C and with a 3.3-V supply.

‡ t_{sk(p)} is the magnitude of the time difference between the high-to-low and low-to-high propagation delay times at an output

‡ t_{sk(o)} is the magnitude of the time difference between the outputs of a single device with all of their inputs connected together.

‡ t_{sk(o)} is the magnitude of the difference in propagation delay times between any specified terminals of two devices when both devices operate with the same supply voltages, same temperature, and have identical packages and test circuits.

PARAMETER MEASUREMENT INFORMATION

driver

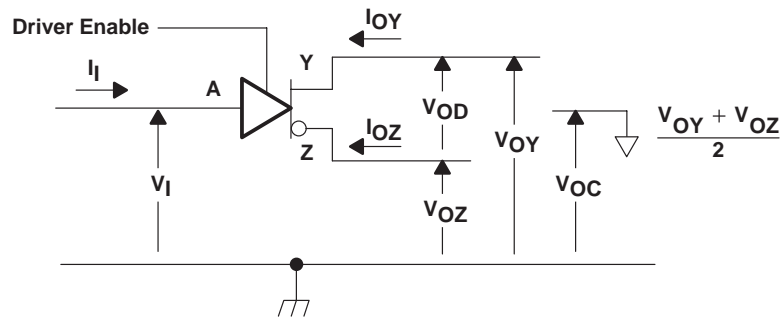

Figure 1. Driver Voltage and Current Definitions

SN75LVDS179, SN75LVDS180, SN75LVDS050, SN75LVDS051 HIGH-SPEED DIFFERENTIAL LINE DRIVERS AND RECEIVERS

SLLS361A – JUNE 1999 – REVISED MARCH 2000

PARAMETER MEASUREMENT INFORMATION

driver (continued)

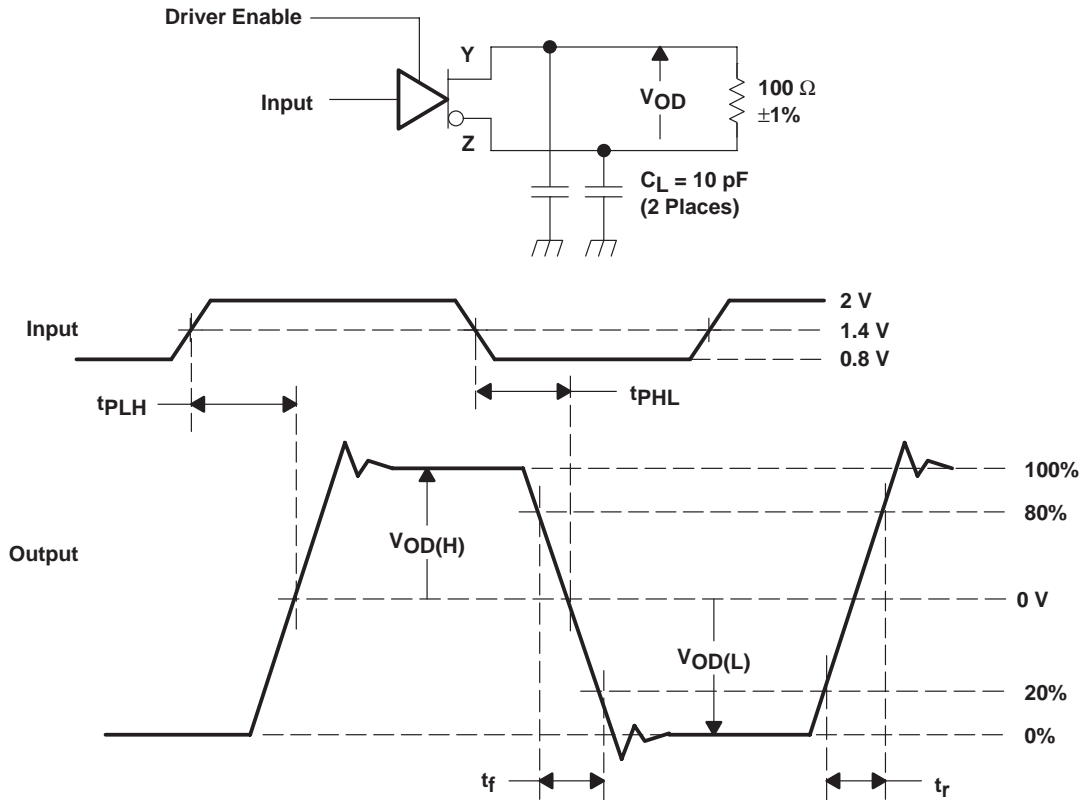

NOTE A: All input pulses are supplied by a generator having the following characteristics: t_r or $t_f \leq 1$ ns, pulse repetition rate (PRR) = 50 Mpps, pulse width = 10 ± 0.2 ns. C_L includes instrumentation and fixture capacitance within 0,06 mm of the D.U.T.

Figure 2. Test Circuit, Timing, and Voltage Definitions for the Differential Output Signal

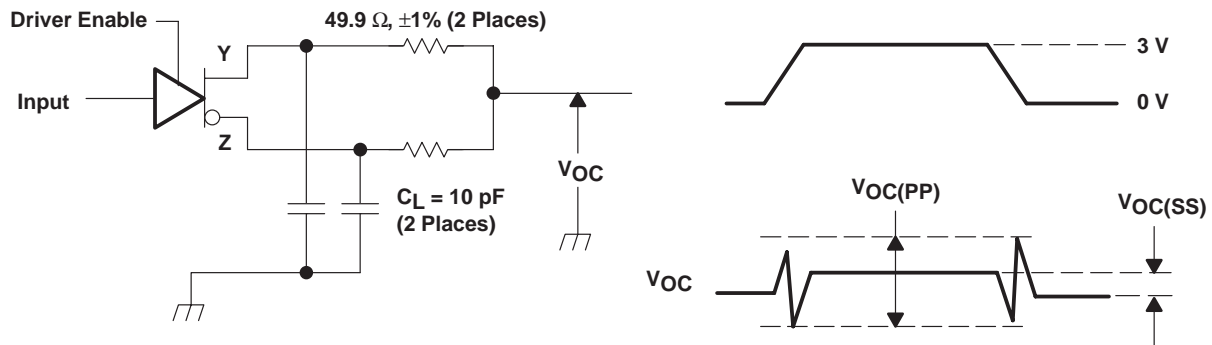

NOTE A: All input pulses are supplied by a generator having the following characteristics: t_r or $t_f \leq 1$ ns, pulse repetition rate (PRR) = 50 Mpps, pulse width = 10 ± 0.2 ns. C_L includes instrumentation and fixture capacitance within 0,06 mm of the D.U.T. The measurement of $V_{OC(PP)}$ is made on test equipment with a -3 dB bandwidth of at least 300 MHz.

Figure 3. Test Circuit and Definitions for the Driver Common-Mode Output Voltage

PARAMETER MEASUREMENT INFORMATION

driver (continued)

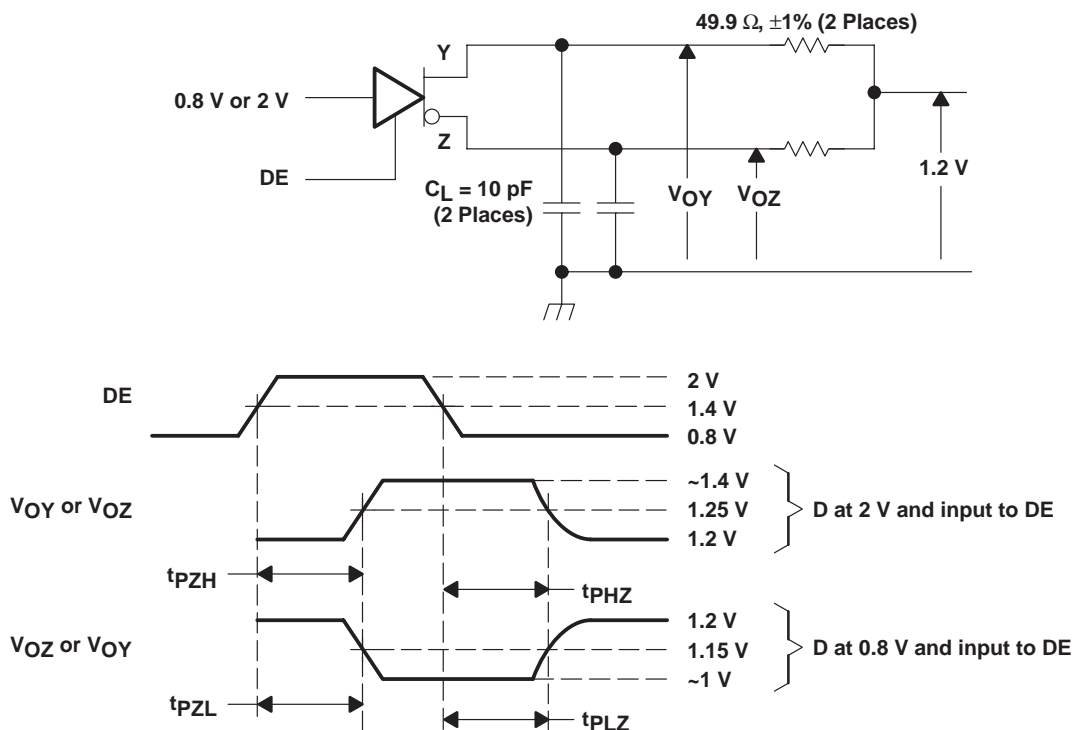

NOTE A: All input pulses are supplied by a generator having the following characteristics: t_r or $t_f \leq 1 \text{ ns}$, pulse repetition rate (PRR) = 0.5 Mpps, pulse width = $500 \pm 10 \text{ ns}$. C_L includes instrumentation and fixture capacitance within 0,06 mm of the D.U.T.

Figure 4. Enable and Disable Time Circuit and Definitions

SN75LVDS179, SN75LVDS180, SN75LVDS050, SN75LVDS051 HIGH-SPEED DIFFERENTIAL LINE DRIVERS AND RECEIVERS

SLLS361A – JUNE 1999 – REVISED MARCH 2000

PARAMETER MEASUREMENT INFORMATION

receiver

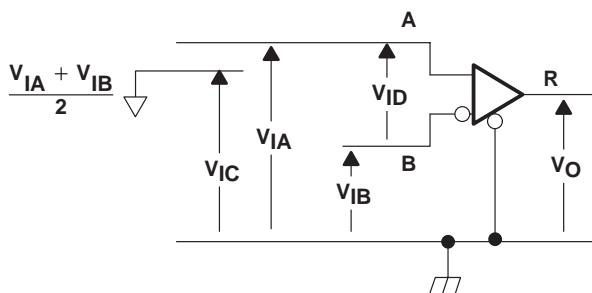

Figure 5. Receiver Voltage Definitions

Table 1. Receiver Minimum and Maximum Input Threshold Test Voltages

APPLIED VOLTAGES (V)		RESULTING DIFFERENTIAL INPUT VOLTAGE (mV)	RESULTING COMMON-MODE INPUT VOLTAGE (V)
V _{IA}	V _{IB}	V _{ID}	V _{IC}
1.25	1.15	100	1.2
1.15	1.25	-100	1.2
2.4	2.3	100	2.35
2.3	2.4	-100	2.35
0.1	0	100	0.05
0	0.1	-100	0.05
1.5	0.9	600	1.2
0.9	1.5	-600	1.2
2.4	1.8	600	2.1
1.8	2.4	-600	2.1
0.6	0	600	0.3
0	0.6	-600	0.3

PARAMETER MEASUREMENT INFORMATION

receiver (continued)

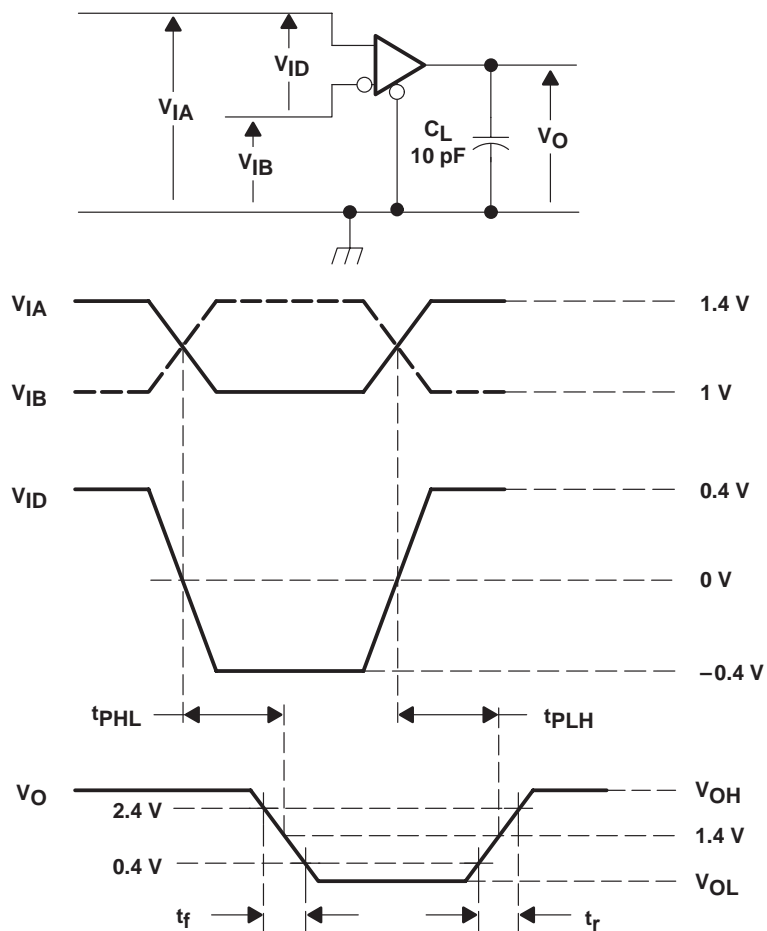

NOTE A: All input pulses are supplied by a generator having the following characteristics: t_r or $t_f \leq 1$ ns, pulse repetition rate (PRR) = 50 Mpps, pulse width = 10 ± 0.2 ns. C_L includes instrumentation and fixture capacitance within 0,06 m of the D.U.T.

Figure 6. Timing Test Circuit and Waveforms

SN75LVDS179, SN75LVDS180, SN75LVDS050, SN75LVDS051 HIGH-SPEED DIFFERENTIAL LINE DRIVERS AND RECEIVERS

SLLS361A – JUNE 1999 – REVISED MARCH 2000

PARAMETER MEASUREMENT INFORMATION

receiver (continued)

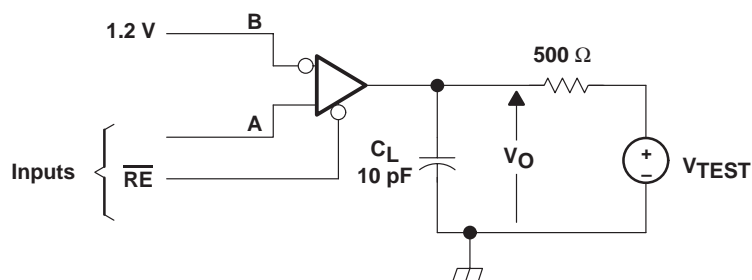

NOTE A: All input pulses are supplied by a generator having the following characteristics: t_r or $t_f \leq 1$ ns, pulse repetition rate (PRR) = 0.5 Mpps, pulse width = 500 ± 10 ns. C_L includes instrumentation and fixture capacitance within 0,06 m of the D.U.T.

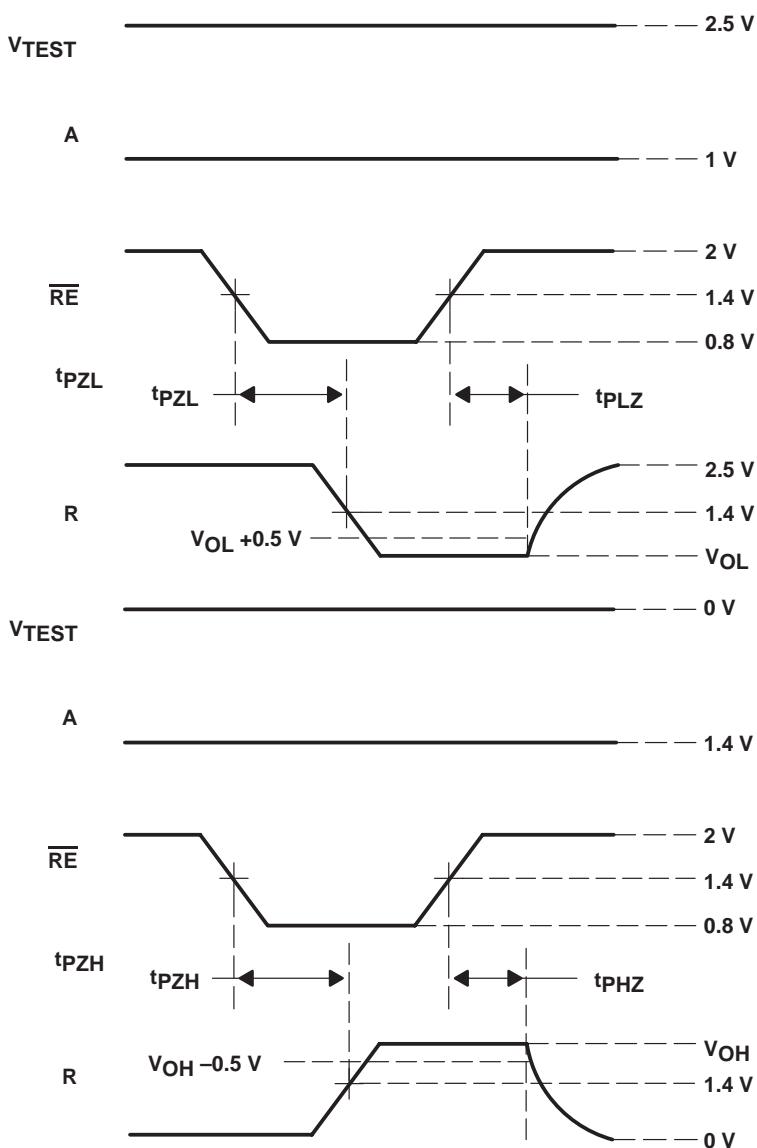

Figure 7. Enable/Disable Time Test Circuit and Waveforms



TYPICAL CHARACTERISTICS

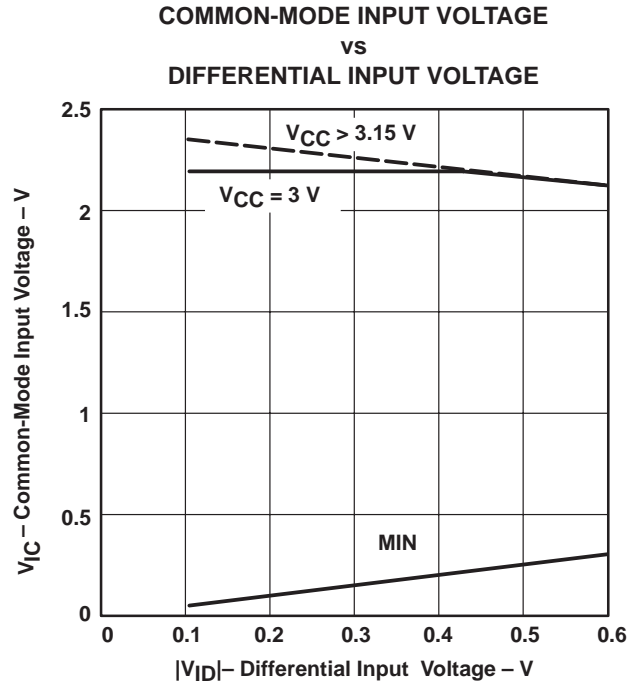

Figure 8

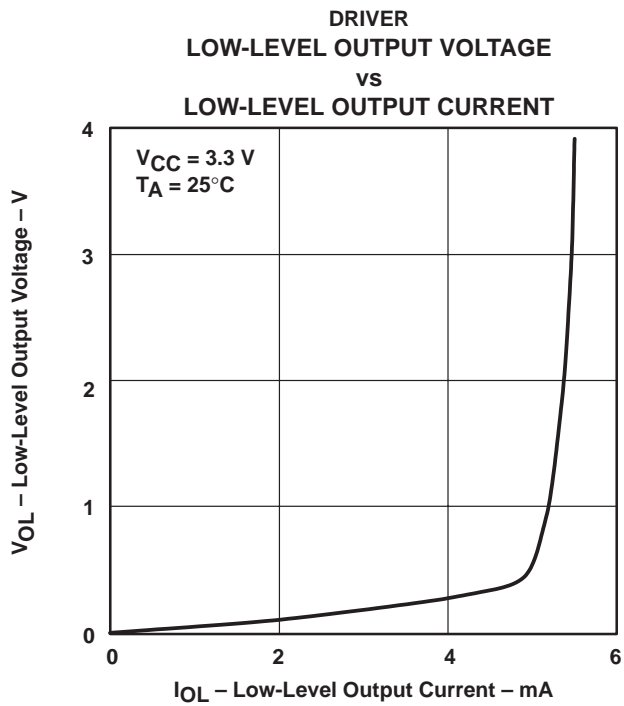

Figure 9

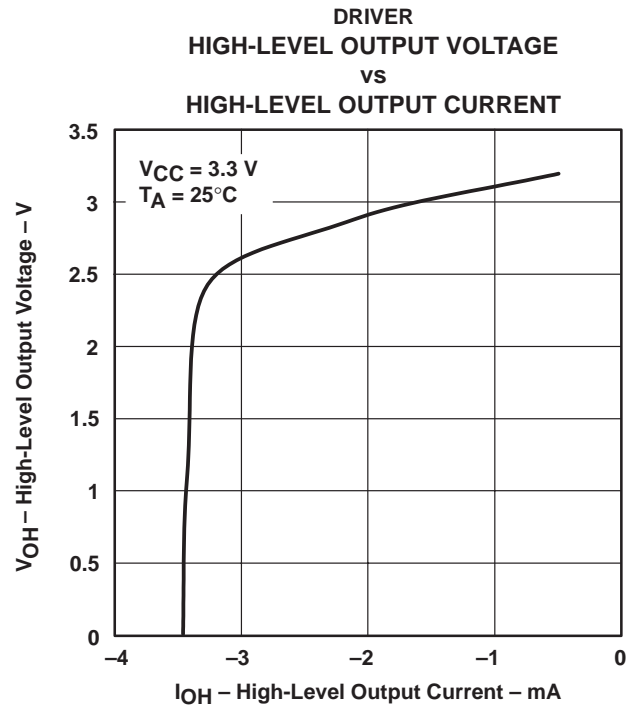

Figure 10

SN75LVDS179, SN75LVDS180, SN75LVDS050, SN75LVDS051 HIGH-SPEED DIFFERENTIAL LINE DRIVERS AND RECEIVERS

SLLS361A – JUNE 1999 – REVISED MARCH 2000

TYPICAL CHARACTERISTICS

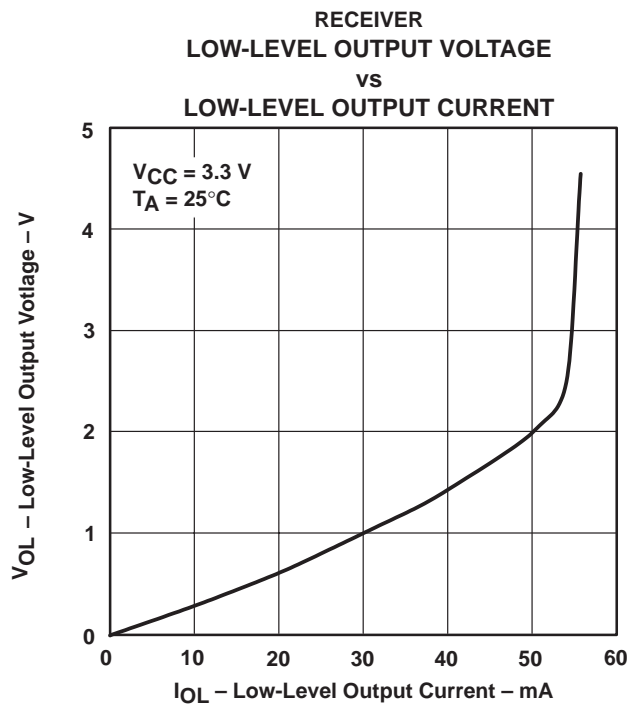

Figure 11

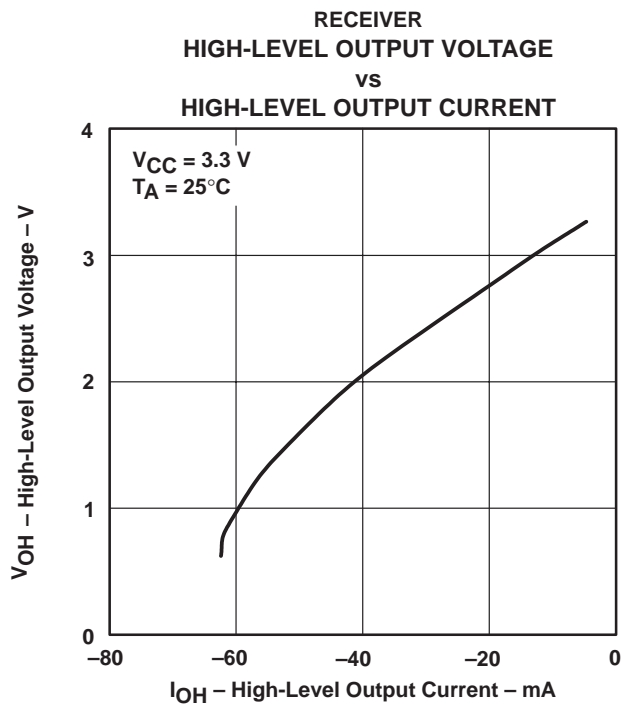

Figure 12

APPLICATION INFORMATION

The devices are generally used as building blocks for high-speed point-to-point data transmission. Ground differences are less than 1 V with a low common-mode output and balanced interface for very low noise emissions. Devices can interoperate with RS-422, PECL, and IEEE-P1596. Drivers/Receivers maintain ECL speeds without the power and dual supply requirements.

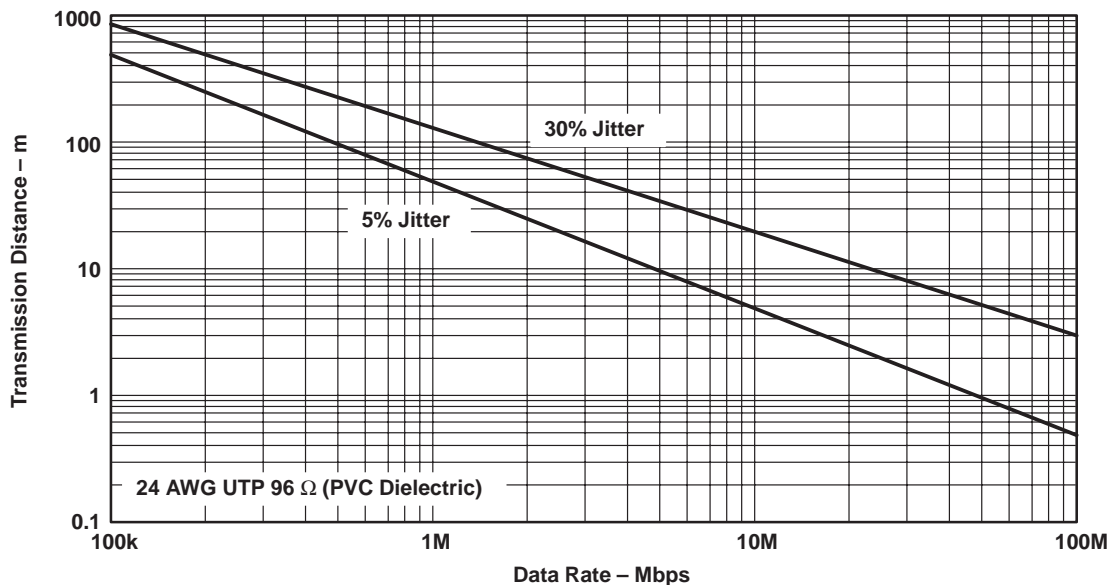

Figure 13. Data Transmission Distance Versus Rate

APPLICATION INFORMATION

fail safe

One of the most common problems with differential signaling applications is how the system responds when no differential voltage is present on the signal pair. The LVDS receiver is like most differential line receivers, in that its output logic state can be indeterminate when the differential input voltage is between -100 mV and 100 mV and within its recommended input common-mode voltage range. TI's LVDS receiver is different in how it handles the open-input circuit situation, however.

Open-circuit means that there is little or no input current to the receiver from the data line itself. This could be when the driver is in a high-impedance state or the cable is disconnected. When this occurs, the LVDS receiver will pull each line of the signal pair to near V_{CC} through $300\text{-k}\Omega$ resistors as shown in Figure 14. The fail-safe feature uses an AND gate with input voltage thresholds at about 2.3 V to detect this condition and force the output to a high-level regardless of the differential input voltage.

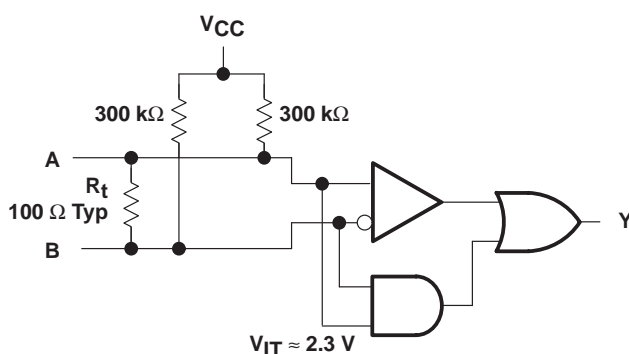

Figure 14. Open-Circuit Fail Safe of the LVDS Receiver

It is only under these conditions that the output of the receiver will be valid with less than a 100-mV differential input voltage magnitude. The presence of the termination resistor, R_t , does not affect the fail-safe function as long as it is connected as shown in the figure. Other termination circuits may allow a dc current to ground that could defeat the pullup currents from the receiver and the fail-safe feature.

SN75LVDS179, SN75LVDS180, SN75LVDS050, SN75LVDS051 HIGH-SPEED DIFFERENTIAL LINE DRIVERS AND RECEIVERS

SLLS361A – JUNE 1999 – REVISED MARCH 2000

MECHANICAL DATA

D (R-PDSO-G**)

PLASTIC SMALL-OUTLINE PACKAGE

14 PIN SHOWN

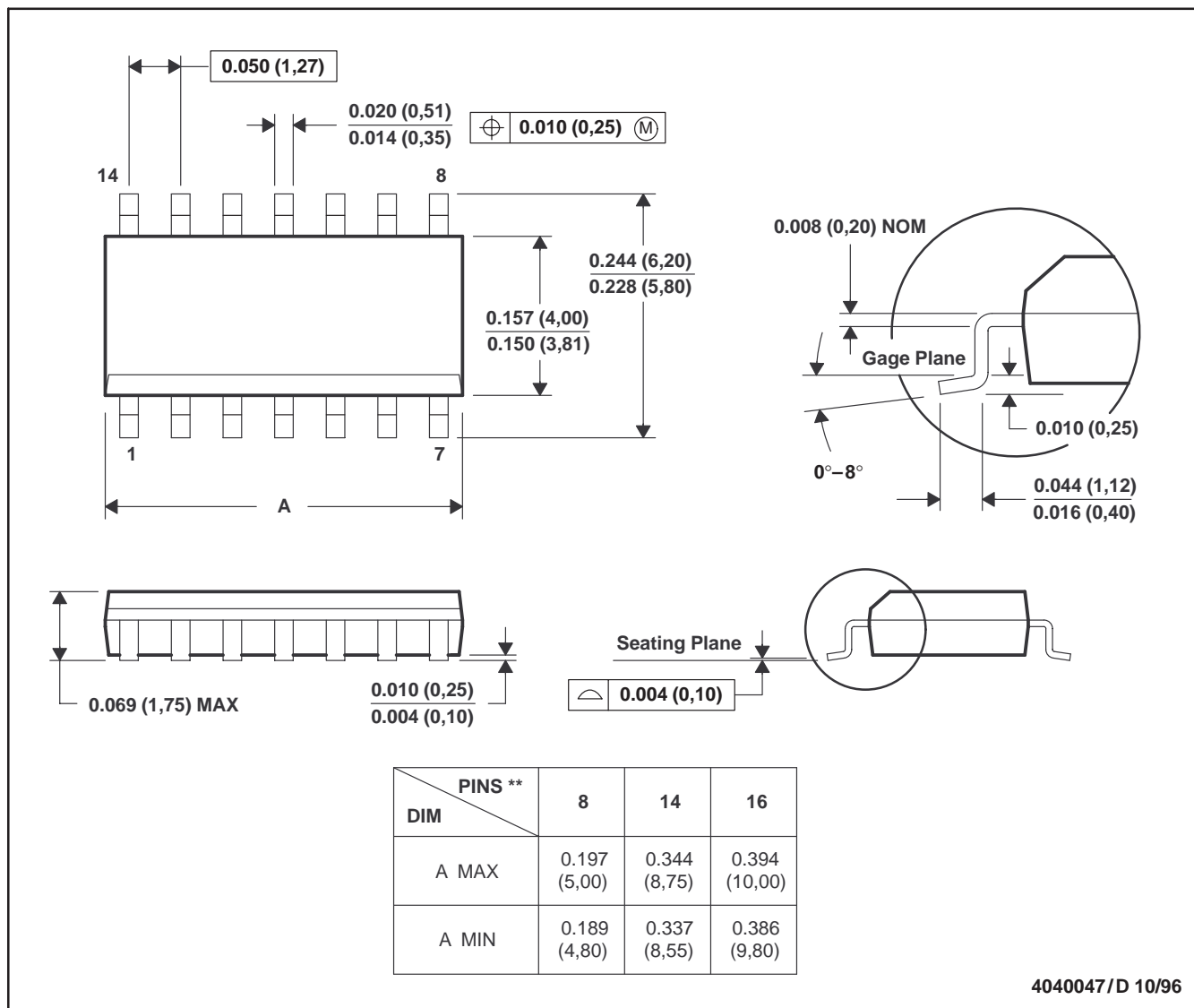

- NOTES: A. All linear dimensions are in inches (millimeters).
 B. This drawing is subject to change without notice.
 C. Body dimensions do not include mold flash or protrusion, not to exceed 0.006 (0,15).
 D. Falls within JEDEC MS-012

PACKAGING INFORMATION

Orderable Device	Status ⁽¹⁾	Package Type	Package Drawing	Pins	Package Qty	Eco Plan ⁽²⁾	Lead/Ball Finish	MSL Peak Temp ⁽³⁾
SN75LVDS051D	ACTIVE	SOIC	D	16	40	Green (RoHS & no Sb/Br)	CU NIPDAU	Level-1-260C-UNLIM
SN75LVDS051DG4	ACTIVE	SOIC	D	16	40	Green (RoHS & no Sb/Br)	CU NIPDAU	Level-1-260C-UNLIM

⁽¹⁾ The marketing status values are defined as follows:

ACTIVE: Product device recommended for new designs.

LIFEBUY: TI has announced that the device will be discontinued, and a lifetime-buy period is in effect.

NRND: Not recommended for new designs. Device is in production to support existing customers, but TI does not recommend using this part in a new design.

PREVIEW: Device has been announced but is not in production. Samples may or may not be available.

OBsolete: TI has discontinued the production of the device.

⁽²⁾ Eco Plan - The planned eco-friendly classification: Pb-Free (RoHS), Pb-Free (RoHS Exempt), or Green (RoHS & no Sb/Br) - please check <http://www.ti.com/productcontent> for the latest availability information and additional product content details.

TBD: The Pb-Free/Green conversion plan has not been defined.

Pb-Free (RoHS): TI's terms "Lead-Free" or "Pb-Free" mean semiconductor products that are compatible with the current RoHS requirements for all 6 substances, including the requirement that lead not exceed 0.1% by weight in homogeneous materials. Where designed to be soldered at high temperatures, TI Pb-Free products are suitable for use in specified lead-free processes.

Pb-Free (RoHS Exempt): This component has a RoHS exemption for either 1) lead-based flip-chip solder bumps used between the die and package, or 2) lead-based die adhesive used between the die and leadframe. The component is otherwise considered Pb-Free (RoHS compatible) as defined above.

Green (RoHS & no Sb/Br): TI defines "Green" to mean Pb-Free (RoHS compatible), and free of Bromine (Br) and Antimony (Sb) based flame retardants (Br or Sb do not exceed 0.1% by weight in homogeneous material)

⁽³⁾ MSL, Peak Temp. -- The Moisture Sensitivity Level rating according to the JEDEC industry standard classifications, and peak solder temperature.

Important Information and Disclaimer:The information provided on this page represents TI's knowledge and belief as of the date that it is provided. TI bases its knowledge and belief on information provided by third parties, and makes no representation or warranty as to the accuracy of such information. Efforts are underway to better integrate information from third parties. TI has taken and continues to take reasonable steps to provide representative and accurate information but may not have conducted destructive testing or chemical analysis on incoming materials and chemicals. TI and TI suppliers consider certain information to be proprietary, and thus CAS numbers and other limited information may not be available for release.

In no event shall TI's liability arising out of such information exceed the total purchase price of the TI part(s) at issue in this document sold by TI to Customer on an annual basis.

IMPORTANT NOTICE

Texas Instruments Incorporated and its subsidiaries (TI) reserve the right to make corrections, modifications, enhancements, improvements, and other changes to its products and services at any time and to discontinue any product or service without notice. Customers should obtain the latest relevant information before placing orders and should verify that such information is current and complete. All products are sold subject to TI's terms and conditions of sale supplied at the time of order acknowledgment.

TI warrants performance of its hardware products to the specifications applicable at the time of sale in accordance with TI's standard warranty. Testing and other quality control techniques are used to the extent TI deems necessary to support this warranty. Except where mandated by government requirements, testing of all parameters of each product is not necessarily performed.

TI assumes no liability for applications assistance or customer product design. Customers are responsible for their products and applications using TI components. To minimize the risks associated with customer products and applications, customers should provide adequate design and operating safeguards.

TI does not warrant or represent that any license, either express or implied, is granted under any TI patent right, copyright, mask work right, or other TI intellectual property right relating to any combination, machine, or process in which TI products or services are used. Information published by TI regarding third-party products or services does not constitute a license from TI to use such products or services or a warranty or endorsement thereof. Use of such information may require a license from a third party under the patents or other intellectual property of the third party, or a license from TI under the patents or other intellectual property of TI.

Reproduction of TI information in TI data books or data sheets is permissible only if reproduction is without alteration and is accompanied by all associated warranties, conditions, limitations, and notices. Reproduction of this information with alteration is an unfair and deceptive business practice. TI is not responsible or liable for such altered documentation. Information of third parties may be subject to additional restrictions.

Resale of TI products or services with statements different from or beyond the parameters stated by TI for that product or service voids all express and any implied warranties for the associated TI product or service and is an unfair and deceptive business practice. TI is not responsible or liable for any such statements.

TI products are not authorized for use in safety-critical applications (such as life support) where a failure of the TI product would reasonably be expected to cause severe personal injury or death, unless officers of the parties have executed an agreement specifically governing such use. Buyers represent that they have all necessary expertise in the safety and regulatory ramifications of their applications, and acknowledge and agree that they are solely responsible for all legal, regulatory and safety-related requirements concerning their products and any use of TI products in such safety-critical applications, notwithstanding any applications-related information or support that may be provided by TI. Further, Buyers must fully indemnify TI and its representatives against any damages arising out of the use of TI products in such safety-critical applications.

TI products are neither designed nor intended for use in military/aerospace applications or environments unless the TI products are specifically designated by TI as military-grade or "enhanced plastic." Only products designated by TI as military-grade meet military specifications. Buyers acknowledge and agree that any such use of TI products which TI has not designated as military-grade is solely at the Buyer's risk, and that they are solely responsible for compliance with all legal and regulatory requirements in connection with such use.

TI products are neither designed nor intended for use in automotive applications or environments unless the specific TI products are designated by TI as compliant with ISO/TS 16949 requirements. Buyers acknowledge and agree that, if they use any non-designated products in automotive applications, TI will not be responsible for any failure to meet such requirements.

Following are URLs where you can obtain information on other Texas Instruments products and application solutions:

Products

Amplifiers	amplifier.ti.com
Data Converters	dataconverter.ti.com
DSP	dsp.ti.com
Clocks and Timers	www.ti.com/clocks
Interface	interface.ti.com
Logic	logic.ti.com
Power Mgmt	power.ti.com
Microcontrollers	microcontroller.ti.com
RFID	www.ti-rfid.com
RF/IF and ZigBee® Solutions	www.ti.com/lprf

Applications

Audio	www.ti.com/audio
Automotive	www.ti.com/automotive
Broadband	www.ti.com/broadband
Digital Control	www.ti.com/digitalcontrol
Medical	www.ti.com/medical
Military	www.ti.com/military
Optical Networking	www.ti.com/opticalnetwork
Security	www.ti.com/security
Telephony	www.ti.com/telephony
Video & Imaging	www.ti.com/video
Wireless	www.ti.com/wireless

Mailing Address: Texas Instruments, Post Office Box 655303, Dallas, Texas 75265
Copyright © 2008, Texas Instruments Incorporated

Looking for pricing, stock, or lifecycle information?

Click below to explore more details on WIN SOURCE:

 [View SN75LVDS179DR on WIN SOURCE](#)

 [Texas Instruments](#) Information

Optimize Your Supply Chain with WIN SOURCE Solutions

-  Global Sourcing Solution
-  Obsolete Management
-  Cost Control Management
-  Shortage Management
-  Alternative Solution
-  Excess Inventory Management