



**THE DATASHEET OF
TMS320F2812GHHQ**



TMS320F2810, TMS320F2811, TMS320F2812 TMS320C2810, TMS320C2811, TMS320C2812 Digital Signal Processors

Data Manual



PRODUCTION DATA information is current as of publication date. Products conform to specifications per the terms of the Texas Instruments standard warranty. Production processing does not necessarily include testing of all parameters.

Literature Number: SPRS174T
April 2001–Revised May 2012

Contents

| | | |
|----------|--|-----------|
| 1 | TMS320F281x, TMS320C281x DSPs | 10 |
| 1.1 | Features | 10 |
| 1.2 | Getting Started | 11 |
| 2 | Introduction | 12 |
| 2.1 | Description | 12 |
| 2.2 | Device Summary | 13 |
| 2.3 | Pin Assignments | 14 |
| 2.3.1 | Terminal Assignments for the GHH/ZHH Packages | 14 |
| 2.3.2 | Pin Assignments for the PGF Package | 15 |
| 2.3.3 | Pin Assignments for the PBK Package | 16 |
| 2.4 | Signal Descriptions | 17 |
| 3 | Functional Overview | 26 |
| 3.1 | Memory Map | 27 |
| 3.2 | Brief Descriptions | 32 |
| 3.2.1 | C28x CPU | 32 |
| 3.2.2 | Memory Bus (Harvard Bus Architecture) | 32 |
| 3.2.3 | Peripheral Bus | 32 |
| 3.2.4 | Real-Time JTAG and Analysis | 33 |
| 3.2.5 | External Interface (XINTF) (2812 Only) | 33 |
| 3.2.6 | Flash (F281x Only) | 33 |
| 3.2.7 | ROM (C281x Only) | 33 |
| 3.2.8 | M0, M1 SARAMs | 34 |
| 3.2.9 | L0, L1, H0 SARAMs | 34 |
| 3.2.10 | Boot ROM | 34 |
| 3.2.11 | Security | 34 |
| 3.2.12 | Peripheral Interrupt Expansion (PIE) Block | 36 |
| 3.2.13 | External Interrupts (XINT1, XINT2, XINT13, XNMI) | 36 |
| 3.2.14 | Oscillator and PLL | 36 |
| 3.2.15 | Watchdog | 36 |
| 3.2.16 | Peripheral Clocking | 36 |
| 3.2.17 | Low-Power Modes | 36 |
| 3.2.18 | Peripheral Frames 0, 1, 2 (PFn) | 37 |
| 3.2.19 | General-Purpose Input/Output (GPIO) Multiplexer | 37 |
| 3.2.20 | 32-Bit CPU-Timers (0, 1, 2) | 37 |
| 3.2.21 | Control Peripherals | 37 |
| 3.2.22 | Serial Port Peripherals | 38 |
| 3.3 | Register Map | 39 |
| 3.4 | Device Emulation Registers | 41 |
| 3.5 | External Interface, XINTF (2812 Only) | 42 |
| 3.5.1 | Timing Registers | 43 |
| 3.5.2 | XREVISION Register | 43 |
| 3.6 | Interrupts | 44 |
| 3.6.1 | External Interrupts | 47 |
| 3.7 | System Control | 48 |
| 3.8 | OSC and PLL Block | 50 |
| 3.8.1 | Loss of Input Clock | 51 |
| 3.9 | PLL-Based Clock Module | 52 |
| 3.10 | External Reference Oscillator Clock Option | 52 |
| 3.11 | Watchdog Block | 53 |
| 3.12 | Low-Power Modes Block | 54 |
| 4 | Peripherals | 55 |

| | | |
|----------|---|---------------------|
| 4.1 | 32-Bit CPU-Timers 0/1/2 | 55 |
| 4.2 | Event Manager Modules (EVA, EVB) | 58 |
| 4.2.1 | General-Purpose (GP) Timers | 61 |
| 4.2.2 | Full-Compare Units | 61 |
| 4.2.3 | Programmable Deadband Generator | 61 |
| 4.2.4 | PWM Waveform Generation | 61 |
| 4.2.5 | Double Update PWM Mode | 61 |
| 4.2.6 | PWM Characteristics | 62 |
| 4.2.7 | Capture Unit | 62 |
| 4.2.8 | Quadrature-Encoder Pulse (QEP) Circuit | 62 |
| 4.2.9 | External ADC Start-of-Conversion | 62 |
| 4.3 | Enhanced Analog-to-Digital Converter (ADC) Module | 63 |
| 4.4 | Enhanced Controller Area Network (eCAN) Module | 68 |
| 4.5 | Multichannel Buffered Serial Port (McBSP) Module | 73 |
| 4.6 | Serial Communications Interface (SCI) Module | 77 |
| 4.7 | Serial Peripheral Interface (SPI) Module | 80 |
| 4.8 | GPIO MUX | 83 |
| 5 | Development Support | 86 |
| 5.1 | Device and Development Support Tool Nomenclature | 86 |
| 5.2 | Documentation Support | 87 |
| 5.3 | Community Resources | 89 |
| 6 | Electrical Specifications | 91 |
| 6.1 | Absolute Maximum Ratings | 91 |
| 6.2 | Recommended Operating Conditions | 91 |
| 6.3 | Electrical Characteristics Over Recommended Operating Conditions (Unless Otherwise Noted) | 92 |
| 6.4 | Current Consumption | 93 |
| 6.5 | Current Consumption Graphs | 95 |
| 6.6 | Reducing Current Consumption | 97 |
| 6.7 | Emulator Connection Without Signal Buffering for the DSP | 97 |
| 6.8 | Power Sequencing Requirements | 98 |
| 6.9 | Signal Transition Levels | 100 |
| 6.10 | Timing Parameter Symbology | 101 |
| 6.11 | General Notes on Timing Parameters | 101 |
| 6.12 | Test Load Circuit | 101 |
| 6.13 | Device Clock Table | 102 |
| 6.14 | Clock Requirements and Characteristics | 103 |
| 6.14.1 | Input Clock Requirements | 103 |
| 6.14.2 | Output Clock Characteristics | 104 |
| 6.15 | Reset Timing | 104 |
| 6.16 | Low-Power Mode Wakeup Timing | 108 |
| 6.17 | Event Manager Interface | 112 |
| 6.17.1 | PWM Timing | 112 |
| 6.17.2 | Interrupt Timing | 114 |
| 6.18 | General-Purpose Input/Output (GPIO) – Output Timing | 115 |
| 6.19 | General-Purpose Input/Output (GPIO) – Input Timing | 116 |
| 6.20 | Serial Peripheral Interface (SPI) Master Mode Timing | 117 |
| 6.21 | Serial Peripheral Interface (SPI) Slave Mode Timing | 122 |
| 6.22 | External Interface (XINTF) Timing | 126 |
| 6.23 | XINTF Signal Alignment to XCLKOUT | 130 |
| 6.24 | External Interface Read Timing | 131 |
| 6.25 | External Interface Write Timing | 133 |
| 6.26 | External Interface Ready-on-Read Timing With One External Wait State | 134 |
| 6.27 | External Interface Ready-on-Write Timing With One External Wait State | 137 |

| | | |
|----------|--|------------|
| 6.28 | $\overline{\text{XHOLD}}$ and $\overline{\text{XHOLDA}}$ | 140 |
| 6.29 | $\overline{\text{XHOLD}}/\overline{\text{XHOLDA}}$ Timing | 141 |
| 6.30 | On-Chip Analog-to-Digital Converter | 143 |
| 6.30.1 | ADC Absolute Maximum Ratings | 143 |
| 6.30.2 | ADC Electrical Characteristics Over Recommended Operating Conditions | 144 |
| 6.30.3 | Current Consumption for Different ADC Configurations | 145 |
| 6.30.4 | ADC Power-Up Control Bit Timing | 146 |
| 6.30.5 | Detailed Description | 146 |
| 6.30.5.1 | Reference Voltage | 146 |
| 6.30.5.2 | Analog Inputs | 146 |
| 6.30.5.3 | Converter | 146 |
| 6.30.5.4 | Conversion Modes | 146 |
| 6.30.6 | Sequential Sampling Mode (Single-Channel) (SMODE = 0) | 147 |
| 6.30.7 | Simultaneous Sampling Mode (Dual-Channel) (SMODE = 1) | 148 |
| 6.30.8 | Definitions of Specifications and Terminology | 149 |
| 6.31 | Multichannel Buffered Serial Port (McBSP) Timing | 150 |
| 6.31.1 | McBSP Transmit and Receive Timing | 150 |
| 6.31.2 | McBSP as SPI Master or Slave Timing | 153 |
| 6.32 | Flash Timing (F281x Only) | 157 |
| 6.33 | ROM Timing (C281x only) | 159 |
| 6.34 | Migrating From F281x Devices to C281x Devices | 160 |
| 7 | Revision History | 161 |
| 8 | Mechanical Data | 162 |

List of Figures

| | | |
|------|---|---------------------|
| 2-1 | TMS320F2812 and TMS320C2812 179-Ball GHH/ZHH MicroStar BGA™ (Bottom View)..... | 14 |
| 2-2 | TMS320F2812 and TMS320C2812 176-Pin PGF LQFP (Top View) | 15 |
| 2-3 | TMS320F2810, TMS320F2811, TMS320C2810, and TMS320C2811 128-Pin PBK LQFP (Top View)..... | 16 |
| 3-1 | Functional Block Diagram | 27 |
| 3-2 | F2812/C2812 Memory Map | 28 |
| 3-3 | F2811/C2811 Memory Map | 29 |
| 3-4 | F2810/C2810 Memory Map | 29 |
| 3-5 | External Interface Block Diagram | 42 |
| 3-6 | Interrupt Sources | 44 |
| 3-7 | Multiplexing of Interrupts Using the PIE Block | 45 |
| 3-8 | Clock and Reset Domains | 48 |
| 3-9 | OSC and PLL Block..... | 50 |
| 3-10 | Recommended Crystal/Clock Connection | 52 |
| 3-11 | Watchdog Module | 53 |
| 4-1 | CPU-Timers | 55 |
| 4-2 | CPU-Timer Interrupts Signals and Output Signal | 56 |
| 4-3 | Event Manager A Functional Block Diagram | 61 |
| 4-4 | Block Diagram of the F281x and C281x ADC Module | 64 |
| 4-5 | ADC Pin Connections With Internal Reference | 65 |
| 4-6 | ADC Pin Connections With External Reference | 66 |
| 4-7 | eCAN Block Diagram and Interface Circuit | 69 |
| 4-8 | eCAN Memory Map | 71 |
| 4-9 | McBSP Module With FIFO | 74 |
| 4-10 | Serial Communications Interface (SCI) Module Block Diagram..... | 79 |
| 4-11 | Serial Peripheral Interface Module Block Diagram (Slave Mode)..... | 82 |
| 4-12 | GPIO/Peripheral Pin Multiplexing | 85 |
| 5-1 | TMS320x281x Device Nomenclature | 87 |
| 6-1 | F2812/F2811/F2810 Typical Current Consumption Over Frequency | 95 |
| 6-2 | F2812/F2811/F2810 Typical Power Consumption Over Frequency..... | 96 |
| 6-3 | C2812/C2811/C2810 Typical Current Consumption Over Frequency | 96 |
| 6-4 | C2812/C2811/C2810 Typical Power Consumption Over Frequency..... | 97 |
| 6-5 | Emulator Connection Without Signal Buffering for the DSP..... | 98 |
| 6-6 | F2812/F2811/F2810 Typical Power-Up and Power-Down Sequence – Option 2 | 99 |
| 6-7 | Output Levels..... | 100 |
| 6-8 | Input Levels..... | 100 |
| 6-9 | 3.3-V Test Load Circuit..... | 101 |
| 6-10 | Clock Timing..... | 104 |
| 6-11 | Power-on Reset in Microcomputer Mode ($XMP/\overline{MC} = 0$) (See Note D) | 106 |
| 6-12 | Power-on Reset in Microprocessor Mode ($XMP/\overline{MC} = 1$) | 107 |
| 6-13 | Warm Reset in Microcomputer Mode | 107 |
| 6-14 | Effect of Writing Into PLLCR Register | 107 |
| 6-15 | IDLE Entry and Exit Timing..... | 108 |
| 6-16 | STANDBY Entry and Exit Timing | 110 |
| 6-17 | HALT Wakeup Using XNMI | 111 |
| 6-18 | PWM Output Timing..... | 112 |
| 6-19 | TDIRx Timing..... | 113 |
| 6-20 | \overline{EVASOC} Timing | 113 |

| | | |
|------|---|---------------------|
| 6-21 | <u>EVBSOC</u> Timing | 113 |
| 6-22 | External Interrupt Timing..... | 114 |
| 6-23 | General-Purpose Output Timing | 115 |
| 6-24 | GPIO Input Qualifier – Example Diagram for QUALPRD = 1 | 116 |
| 6-25 | General-Purpose Input Timing | 117 |
| 6-26 | SPI Master Mode External Timing (Clock Phase = 0) | 119 |
| 6-27 | SPI Master External Timing (Clock Phase = 1)..... | 121 |
| 6-28 | SPI Slave Mode External Timing (Clock Phase = 0)..... | 123 |
| 6-29 | SPI Slave Mode External Timing (Clock Phase = 1)..... | 125 |
| 6-30 | Relationship Between XTIMCLK and SYSCLKOUT | 129 |
| 6-31 | Example Read Access | 132 |
| 6-32 | Example Write Access | 133 |
| 6-33 | Example Read With Synchronous XREADY Access | 135 |
| 6-34 | Example Read With Asynchronous XREADY Access | 136 |
| 6-35 | Write With Synchronous XREADY Access | 138 |
| 6-36 | Write With Asynchronous XREADY Access | 139 |
| 6-37 | External Interface Hold Waveform..... | 141 |
| 6-38 | <u>XHOLD</u> / <u>XHOLDA</u> Timing Requirements (XCLKOUT = 1/2 XTIMCLK)..... | 142 |
| 6-39 | ADC Analog Input Impedance Model | 146 |
| 6-40 | ADC Power-Up Control Bit Timing | 146 |
| 6-41 | Sequential Sampling Mode (Single-Channel) Timing | 147 |
| 6-42 | Simultaneous Sampling Mode Timing | 148 |
| 6-43 | McBSP Receive Timing..... | 152 |
| 6-44 | McBSP Transmit Timing | 152 |
| 6-45 | McBSP Timing as SPI Master or Slave: CLKSTP = 10b, CLKXP = 0 | 153 |
| 6-46 | McBSP Timing as SPI Master or Slave: CLKSTP = 11b, CLKXP = 0 | 154 |
| 6-47 | McBSP Timing as SPI Master or Slave: CLKSTP = 10b, CLKXP = 1 | 155 |
| 6-48 | McBSP Timing as SPI Master or Slave: CLKSTP = 11b, CLKXP = 1 | 156 |

List of Tables

| | | |
|------|--|---------------------|
| 2-1 | Hardware Features..... | 13 |
| 2-2 | Signal Descriptions..... | 17 |
| 3-1 | Addresses of Flash Sectors in F2812 and F2811 | 30 |
| 3-2 | Addresses of Flash Sectors in F2810 | 30 |
| 3-3 | Wait States | 31 |
| 3-4 | Boot Mode Selection | 34 |
| 3-5 | Impact of Using the Code Security Module | 35 |
| 3-6 | Peripheral Frame 0 Registers | 39 |
| 3-7 | Peripheral Frame 1 Registers | 39 |
| 3-8 | Peripheral Frame 2 Registers | 40 |
| 3-9 | Device Emulation Registers..... | 41 |
| 3-10 | XINTF Configuration and Control Register Mappings | 43 |
| 3-11 | XREVISION Register Bit Definitions | 43 |
| 3-12 | PIE Peripheral Interrupts | 45 |
| 3-13 | PIE Configuration and Control Registers..... | 46 |
| 3-14 | External Interrupts Registers | 47 |
| 3-15 | PLL, Clocking, Watchdog, and Low-Power Mode Registers | 49 |
| 3-16 | PLLCR Register Bit Definitions | 51 |
| 3-17 | Possible PLL Configuration Modes | 52 |
| 3-18 | F281x and C281x Low-Power Modes | 54 |
| 4-1 | CPU-Timers 0, 1, 2 Configuration and Control Registers..... | 57 |
| 4-2 | Module and Signal Names for EVA and EVB | 58 |
| 4-3 | EVA Registers | 59 |
| 4-4 | ADC Registers | 67 |
| 4-5 | 3.3-V eCAN Transceivers for the TMS320F281x and TMS320C281x DSPs | 70 |
| 4-6 | CAN Registers | 72 |
| 4-7 | McBSP Registers..... | 75 |
| 4-8 | SCI-A Registers | 78 |
| 4-9 | SCI-B Registers | 78 |
| 4-10 | SPI Registers | 81 |
| 4-11 | GPIO Mux Registers | 83 |
| 4-12 | GPIO Data Registers | 84 |
| 5-1 | TMS320x281x Peripheral Selection Guide | 87 |
| 6-1 | TMS320F281x Current Consumption by Power-Supply Pins Over Recommended Operating Conditions During Low-Power Modes at 150-MHz SYSCLKOUT | 93 |
| 6-2 | TMS320C281x Current Consumption by Power-Supply Pins Over Recommended Operating Conditions During Low-Power Modes at 150-MHz SYSCLKOUT | 94 |
| 6-3 | Typical Current Consumption by Various Peripherals (at 150 MHz) | 97 |
| 6-4 | Recommended “Low-Dropout Regulators”..... | 98 |
| 6-5 | TMS320F281x and TMS320C281x Clock Table and Nomenclature | 102 |
| 6-6 | Input Clock Frequency | 103 |
| 6-7 | XCLKIN Timing Requirements – PLL Bypassed or Enabled | 103 |
| 6-8 | XCLKIN Timing Requirements – PLL Disabled | 103 |
| 6-9 | Possible PLL Configuration Modes..... | 103 |
| 6-10 | XCLKOUT Switching Characteristics (PLL Bypassed or Enabled) | 104 |
| 6-11 | Reset (\overline{XRS}) Timing Requirements | 104 |
| 6-12 | IDLE Mode Timing Requirements | 108 |

| | | |
|------|--|---------------------|
| 6-13 | IDLE Mode Switching Characteristics | 108 |
| 6-14 | STANDBY Mode Timing Requirements | 109 |
| 6-15 | STANDBY Mode Switching Characteristics | 109 |
| 6-16 | HALT Mode Timing Requirements | 111 |
| 6-17 | HALT Mode Switching Characteristics | 111 |
| 6-18 | PWM Switching Characteristics | 112 |
| 6-19 | Timer and Capture Unit Timing Requirements | 112 |
| 6-20 | External ADC Start-of-Conversion – EVA – Switching Characteristics | 113 |
| 6-21 | External ADC Start-of-Conversion – EVB – Switching Characteristics | 113 |
| 6-22 | Interrupt Switching Characteristics | 114 |
| 6-23 | Interrupt Timing Requirements | 114 |
| 6-24 | General-Purpose Output Switching Characteristics | 115 |
| 6-25 | General-Purpose Input Timing Requirements | 117 |
| 6-26 | SPI Master Mode External Timing (Clock Phase = 0) | 118 |
| 6-27 | SPI Master Mode External Timing (Clock Phase = 1) | 120 |
| 6-28 | SPI Slave Mode External Timing (Clock Phase = 0) | 122 |
| 6-29 | SPI Slave Mode External Timing (Clock Phase = 1) | 124 |
| 6-30 | Relationship Between Parameters Configured in XTIMING and Duration of Pulse | 126 |
| 6-31 | XINTF Clock Configurations | 129 |
| 6-32 | External Memory Interface Read Switching Characteristics | 131 |
| 6-33 | External Memory Interface Read Timing Requirements | 131 |
| 6-34 | External Memory Interface Write Switching Characteristics | 133 |
| 6-35 | External Memory Interface Read Switching Characteristics (Ready-on-Read, 1 Wait State) | 134 |
| 6-36 | External Memory Interface Read Timing Requirements (Ready-on-Read, 1 Wait State) | 134 |
| 6-37 | Synchronous XREADY Timing Requirements (Ready-on-Read, 1 Wait State) | 134 |
| 6-38 | Asynchronous XREADY Timing Requirements (Ready-on-Read, 1 Wait State) | 134 |
| 6-39 | External Memory Interface Write Switching Characteristics (Ready-on-Write, 1 Wait State) | 137 |
| 6-40 | Synchronous XREADY Timing Requirements (Ready-on-Write, 1 Wait State) | 137 |
| 6-41 | Asynchronous XREADY Timing Requirements (Ready-on-Write, 1 Wait State) | 137 |
| 6-42 | XHOLD/XHOLD \bar{A} Timing Requirements (XCLKOUT = XTIMCLK) | 141 |
| 6-43 | XHOLD/XHOLD \bar{A} Timing Requirements (XCLKOUT = 1/2 XTIMCLK) | 142 |
| 6-44 | DC Specifications | 144 |
| 6-45 | AC Specifications | 145 |
| 6-46 | Current Consumption for Different ADC Configurations (at 25-MHz ADCCLK) | 145 |
| 6-47 | ADC Power-Up Delays | 146 |
| 6-48 | Sequential Sampling Mode Timing | 147 |
| 6-49 | Simultaneous Sampling Mode Timing | 148 |
| 6-50 | McBSP Timing Requirements | 150 |
| 6-51 | McBSP Switching Characteristics | 151 |
| 6-52 | McBSP as SPI Master or Slave Timing Requirements (CLKSTP = 10b, CLKXP = 0) | 153 |
| 6-53 | McBSP as SPI Master or Slave Switching Characteristics (CLKSTP = 10b, CLKXP = 0) | 153 |
| 6-54 | McBSP as SPI Master or Slave Timing Requirements (CLKSTP = 11b, CLKXP = 0) | 154 |
| 6-55 | McBSP as SPI Master or Slave Switching Characteristics (CLKSTP = 11b, CLKXP = 0) | 154 |
| 6-56 | McBSP as SPI Master or Slave Timing Requirements (CLKSTP = 10b, CLKXP = 1) | 155 |
| 6-57 | McBSP as SPI Master or Slave Switching Characteristics (CLKSTP = 10b, CLKXP = 1) | 155 |
| 6-58 | McBSP as SPI Master or Slave Timing Requirements (CLKSTP = 11b, CLKXP = 1) | 156 |
| 6-59 | McBSP as SPI Master or Slave Switching Characteristics (CLKSTP = 11b, CLKXP = 1) | 156 |
| 6-60 | Flash Endurance for A and S Temperature Material | 157 |

| | | |
|------|---|---------------------|
| 6-61 | Flash Endurance for Q Temperature Material | 157 |
| 6-62 | Flash Parameters at 150-MHz SYSCLKOUT | 157 |
| 6-63 | Flash/OTP Access Timing | 158 |
| 6-64 | Minimum Required Flash Wait States at Different Frequencies (F281x devices) | 158 |
| 6-65 | ROM Access Timing | 159 |
| 6-66 | Minimum Required ROM Wait States at Different Frequencies (C281x devices) | 159 |
| 8-1 | Thermal Resistance Characteristics for 179-Ball GHH | 162 |
| 8-2 | Thermal Resistance Characteristics for 179-Ball ZHH | 162 |
| 8-3 | Thermal Resistance Characteristics for 176-Pin PGF | 162 |
| 8-4 | Thermal Resistance Characteristics for 128-Pin PBK | 162 |

Digital Signal Processors

Check for Samples: [TMS320F2810](#), [TMS320F2811](#), [TMS320F2812](#), [TMS320C2810](#), [TMS320C2811](#), [TMS320C2812](#)

1 TMS320F281x, TMS320C281x DSPs

1.1 Features

- **High-Performance Static CMOS Technology**
 - 150 MHz (6.67-ns Cycle Time)
 - Low-Power (1.8-V Core at 135 MHz, 1.9-V Core at 150 MHz, 3.3-V I/O) Design
- **JTAG Boundary Scan Support** ⁽¹⁾
- **High-Performance 32-Bit CPU (TMS320C28x™)**
 - 16 x 16 and 32 x 32 MAC Operations
 - 16 x 16 Dual MAC
 - Harvard Bus Architecture
 - Atomic Operations
 - Fast Interrupt Response and Processing
 - Unified Memory Programming Model
 - 4M Linear Program/Data Address Reach
 - Code-Efficient (in C/C++ and Assembly)
 - TMS320F24x/LF240x Processor Source Code Compatible
- **On-Chip Memory**
 - Flash Devices: Up to 128K x 16 Flash (Four 8K x 16 and Six 16K x 16 Sectors)
 - ROM Devices: Up to 128K x 16 ROM
 - 1K x 16 OTP ROM
 - L0 and L1: 2 Blocks of 4K x 16 Each Single-Access RAM (SARAM)
 - H0: 1 Block of 8K x 16 SARAM
 - M0 and M1: 2 Blocks of 1K x 16 Each SARAM
- **Boot ROM (4K x 16)**
 - With Software Boot Modes
 - Standard Math Tables
- **External Interface (2812)**
 - Over 1M x 16 Total Memory
 - Programmable Wait States
 - Programmable Read/Write Strobe Timing
 - Three Individual Chip Selects
- **Endianness: Little Endian**
- **Clock and System Control**
 - Dynamic PLL Ratio Changes Supported
 - On-Chip Oscillator
 - Watchdog Timer Module
- **Three External Interrupts**
- **Peripheral Interrupt Expansion (PIE) Block That Supports 45 Peripheral Interrupts**
- **Three 32-Bit CPU-Timers**
- **128-Bit Security Key/Lock**
 - Protects Flash/ROM/OTP and L0/L1 SARAM
 - Prevents Firmware Reverse-Engineering
- **Motor Control Peripherals**
 - Two Event Managers (EVA, EVB)
 - Compatible to 240xA Devices
- **Serial Port Peripherals**
 - Serial Peripheral Interface (SPI)
 - Two Serial Communications Interfaces (SCIs), Standard UART
 - Enhanced Controller Area Network (eCAN)
 - Multichannel Buffered Serial Port (McBSP)
- **12-Bit ADC, 16 Channels**
 - 2 x 8 Channel Input Multiplexer
 - Two Sample-and-Hold
 - Single/Simultaneous Conversions
 - Fast Conversion Rate: 80 ns/12.5 MSPS
- **Up to 56 General-Purpose I/O (GPIO) Pins**
- **Advanced Emulation Features**
 - Analysis and Breakpoint Functions
 - Real-Time Debug via Hardware
- **Development Tools Include**
 - ANSI C/C++ Compiler/Assembler/Linker
 - Code Composer Studio™ IDE
 - DSP/BIOS™
 - JTAG Scan Controllers⁽¹⁾
- **Low-Power Modes and Power Savings**
 - IDLE, STANDBY, HALT Modes Supported
 - Disable Individual Peripheral Clocks

(1) IEEE Standard 1149.1-1990 IEEE Standard Test Access Port and Boundary-Scan Architecture



Please be aware that an important notice concerning availability, standard warranty, and use in critical applications of Texas Instruments semiconductor products and disclaimers thereto appears at the end of this data sheet.

MicroStar BGA, TMS320C28x, Code Composer Studio, DSP/BIOS, C28x, TMS320C2000, TI, TMS320C54x, TMS320C55x, TMS320 are trademarks of Texas Instruments.

eZdsp is a trademark of Spectrum Digital Incorporated.

All other trademarks are the property of their respective owners.

- **Package Options**
 - 179-Ball MicroStar BGA™ With External Memory Interface (GHH, ZHH) (2812)
 - 176-Pin Low-Profile Quad Flatpack (LQFP) With External Memory Interface (PGF) (2812)
 - 128-Pin LQFP Without External Memory Interface (PBK) (2810, 2811)
- **Temperature Options**
 - A: –40°C to 85°C (GHH, ZHH, PGF, PBK)
 - S: –40°C to 125°C (GHH, ZHH, PGF, PBK)
 - Q: –40°C to 125°C (PGF, PBK) [Q100 Qualification]

1.2 Getting Started

This section gives a brief overview of the steps to take when first developing for a C28x™ device. For more detail on each of these steps, see the following:

- *Getting Started With TMS320C28x Digital Signal Controllers* (literature number [SPRAAM0](#))
- C2000 Getting Started Website (<http://www.ti.com/c2000getstarted>)
- TMS320F28x DSC Development and Experimenter's Kits (<http://www.ti.com/f28xkits>)

2 Introduction

This section provides a summary of each device's features, lists the pin assignments, and describes the function of each pin. This document also provides detailed descriptions of peripherals, electrical specifications, parameter measurement information, and mechanical data about the available packaging.

2.1 Description

The TMS320F2810, TMS320F2811, TMS320F2812, TMS320C2810, TMS320C2811, and TMS320C2812 devices, members of the TMS320C28x™ DSP generation, are highly integrated, high-performance solutions for demanding control applications. The functional blocks and the memory maps are described in [Section 3](#), Functional Overview.

Throughout this document, TMS320F2810, TMS320F2811, and TMS320F2812 are abbreviated as F2810, F2811, and F2812, respectively. F281x denotes all three Flash devices. TMS320C2810, TMS320C2811, and TMS320C2812 are abbreviated as C2810, C2811, and C2812, respectively. C281x denotes all three ROM devices. 2810 denotes both F2810 and C2810 devices; 2811 denotes both F2811 and C2811 devices; and 2812 denotes both F2812 and C2812 devices.

2.2 Device Summary

Table 2-1 provides a summary of each device's features.

Table 2-1. Hardware Features⁽¹⁾

| FEATURE | | TYPE ⁽²⁾ | F2810 | F2811 | F2812 | C2810 | C2811 | C2812 |
|--|--|---------------------|---|---------------|---------------|--------------------|--------------------|--------------------|
| Instruction Cycle (at 150 MHz) | | – | 6.67 ns | 6.67 ns | 6.67 ns | 6.67 ns | 6.67 ns | 6.67 ns |
| Single-Access RAM (SARAM) (16-bit word) | | – | 18K | 18K | 18K | 18K | 18K | 18K |
| 3.3-V On-Chip Flash (16-bit word) | | – | 64K | 128K | 128K | – | – | – |
| On-Chip ROM (16-bit word) | | – | – | – | – | 64K | 128K | 128K |
| Code Security for On-Chip Flash/SARAM/OTP/ROM | | – | Yes | Yes | Yes | Yes | Yes | Yes |
| Boot ROM | | – | Yes | Yes | Yes | Yes | Yes | Yes |
| OTP ROM (1K x 16) | | – | Yes | Yes | Yes | Yes ⁽³⁾ | Yes ⁽³⁾ | Yes ⁽³⁾ |
| External Memory Interface | | 0 | – | – | Yes | – | – | Yes |
| Event Managers A and B (EVA and EVB) | | – | EVA, EVB | EVA, EVB | EVA, EVB | EVA, EVB | EVA, EVB | EVA, EVB |
| • General-Purpose (GP) Timers | | – | 4 | 4 | 4 | 4 | 4 | 4 |
| • Compare (CMP)/PWM | | 0 | 16 | 16 | 16 | 16 | 16 | 16 |
| • Capture (CAP)/QEP Channels | | 0 | 6/2 | 6/2 | 6/2 | 6/2 | 6/2 | 6/2 |
| Watchdog Timer | | – | Yes | Yes | Yes | Yes | Yes | Yes |
| 12-Bit ADC | | 0 | Yes | Yes | Yes | Yes | Yes | Yes |
| • Channels | | | 16 | 16 | 16 | 16 | 16 | 16 |
| 32-Bit CPU Timers | | – | 3 | 3 | 3 | 3 | 3 | 3 |
| Serial Peripheral Interface (SPI) | | 0 | Yes | Yes | Yes | Yes | Yes | Yes |
| Serial Communications Interfaces A and B (SCIA and SCIB) | | 0 | SCIA, SCIB | SCIA, SCIB | SCIA, SCIB | SCIA, SCIB | SCIA, SCIB | SCIA, SCIB |
| Controller Area Network (CAN) | | 0 | Yes | Yes | Yes | Yes | Yes | Yes |
| Multichannel Buffered Serial Port (McBSP) | | 0 | Yes | Yes | Yes | Yes | Yes | Yes |
| Digital I/O Pins (Shared) | | – | 56 | 56 | 56 | 56 | 56 | 56 |
| External Interrupts | | – | 3 | 3 | 3 | 3 | 3 | 3 |
| Supply Voltage | | – | 1.8-V Core (135 MHz), 1.9-V Core (150 MHz), 3.3-V I/O | | | | | |
| Packaging | 128-pin PBK | – | Yes | Yes | – | Yes | Yes | – |
| | 176-pin PGF | | – | – | Yes | – | – | Yes |
| | 179-ball GHH | | – | – | Yes | – | – | Yes |
| | 179-ball ZHH | | – | – | Yes | – | – | Yes |
| Temperature Options | A: –40°C to 85°C | – | Yes | Yes | Yes | Yes | Yes | Yes |
| | S: –40°C to 125°C | – | Yes | Yes | Yes | Yes | Yes | Yes |
| | Q: –40°C to 125°C (Q100 Qualification) | – | Yes | Yes | PGF only | Yes | Yes | PGF only |
| Product Status ⁽⁴⁾ | | – | TMS | TMS | TMS | TMS | TMS | TMS |

(1) The TMS320F2810, TMS320F2811, TMS320F2812, TMS320C2810, TMS320C2811, TMS320C2812 DSP Silicon Errata (literature number [SPRZ193](#)) has been posted on the Texas Instruments (TI) website. It will be updated as needed.

(2) A type change represents a major functional feature difference in a peripheral module. Within a peripheral type, there may be minor differences between devices that do not affect the basic functionality of the module. These device-specific differences are listed in the TMS320x28xx, 28xxx DSP Peripheral Reference Guide (literature number [SPRU566](#)) and in the peripheral reference guides.

(3) On C281x devices, OTP is replaced by a 1K x 16 block of ROM.

(4) See [Section 5.1](#), Device and Development Support Tool Nomenclature, for descriptions of device stages.

2.3 Pin Assignments

Figure 2-1 illustrates the ball locations for the 179-ball GHH and ZHH ball grid array (BGA) packages. Figure 2-2 shows the pin assignments for the 176-pin PGF low-profile quad flatpack (LQFP) and Figure 2-3 shows the pin assignments for the 128-pin PBK LQFP. Table 2-2 describes the function(s) of each pin.

2.3.1 Terminal Assignments for the GHH/ZHH Packages

See Table 2-2 for a description of each terminal's function(s).

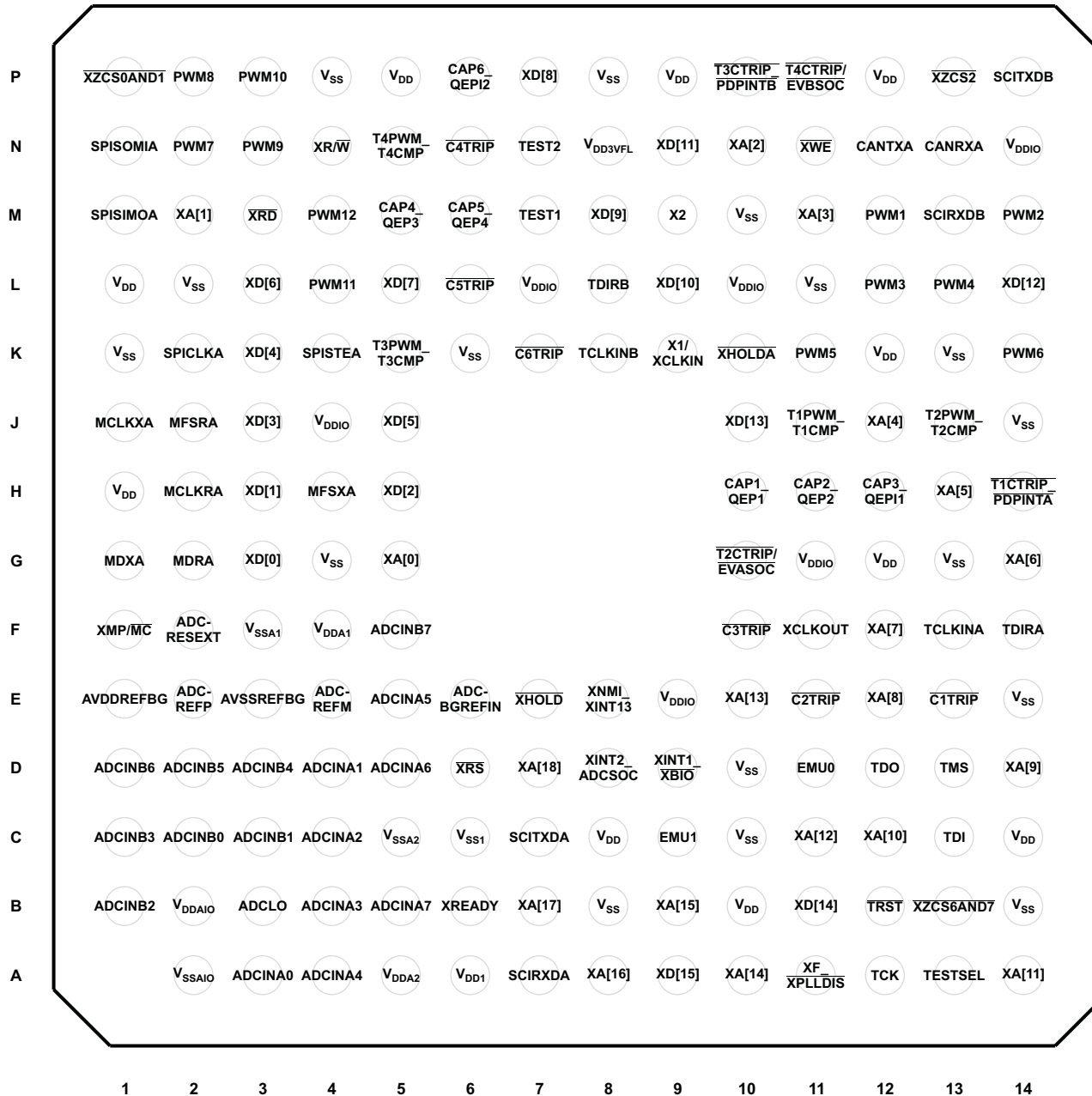

Figure 2-1. TMS320F2812 and TMS320C2812 179-Ball GHH/ZHH MicroStar BGA™ (Bottom View)

2.3.2 Pin Assignments for the PGF Package

The TMS320F2812 and TMS320C2812 176-pin PGF low-profile quad flatpack (LQFP) pin assignments are shown in Figure 2-2. See Table 2-2 for a description of each pin's function(s).

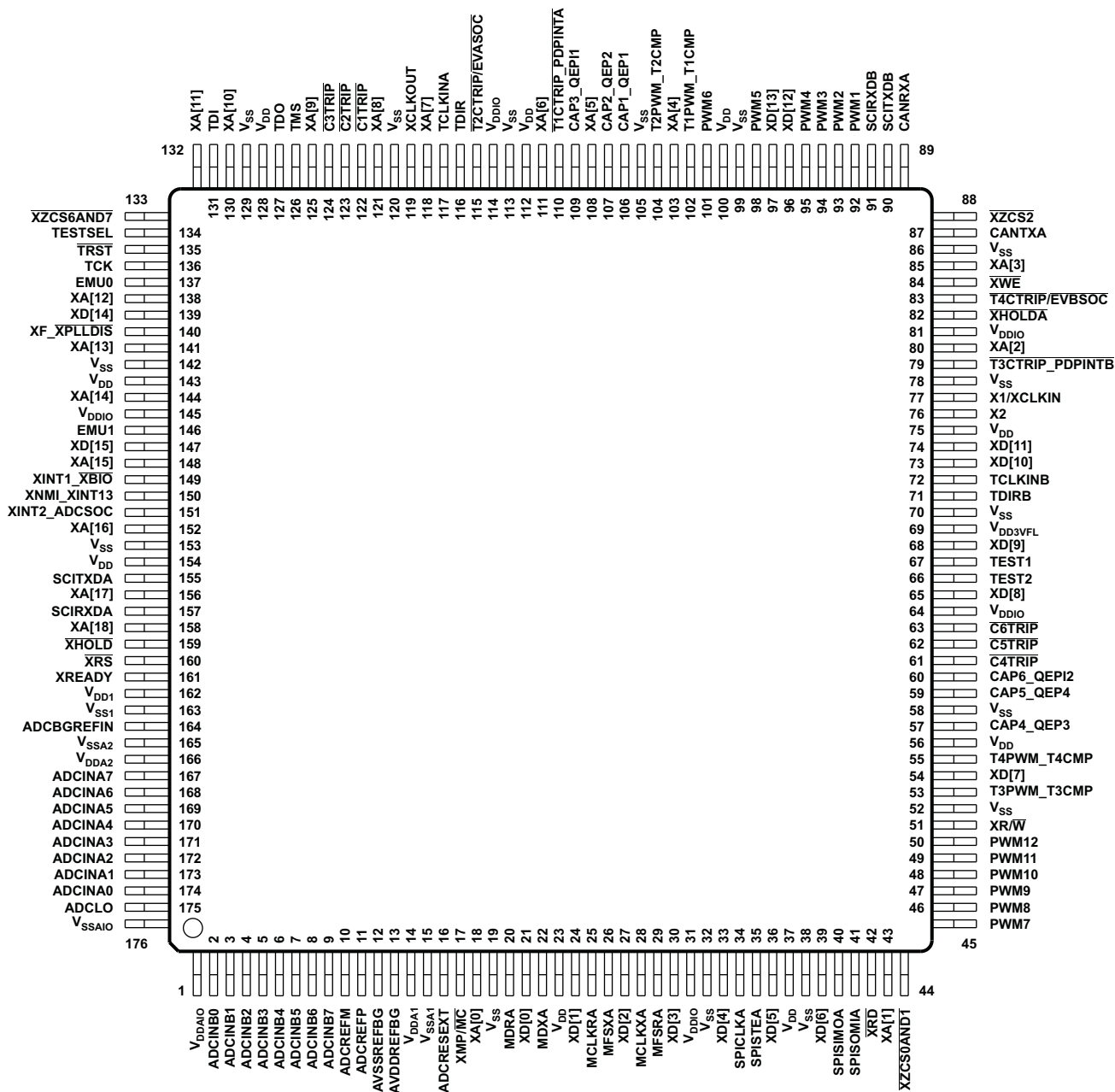

Figure 2-2. TMS320F2812 and TMS320C2812 176-Pin PGF LQFP (Top View)

2.3.3 Pin Assignments for the PBK Package

The TMS320F2810, TMS320F2811, TMS320C2810, and TMS320C2811 128-pin PBK low-profile quad flatpack (LQFP) pin assignments are shown in Figure 2-3. See Table 2-2 for a description of each pin's function(s).

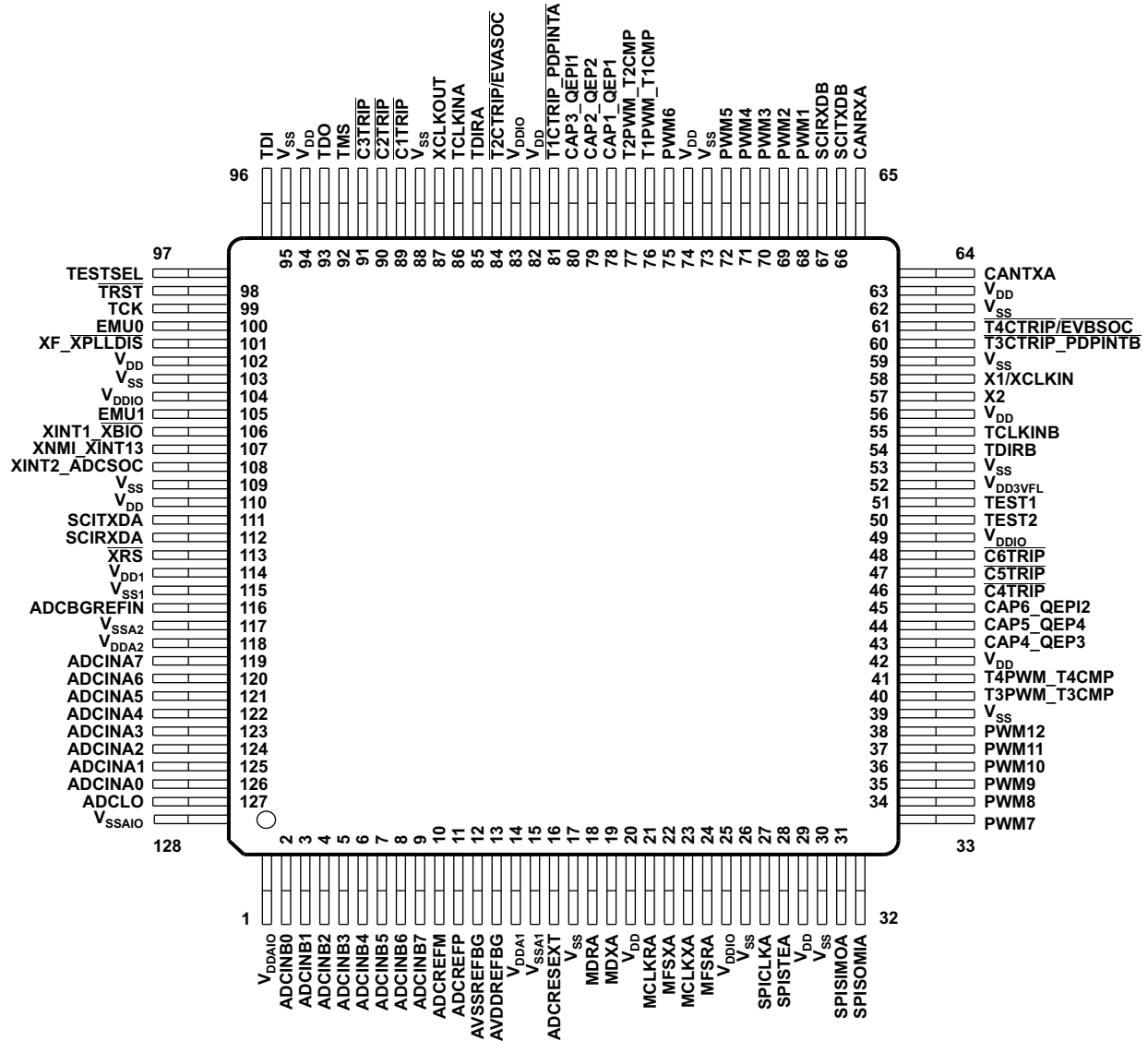

Figure 2-3. TMS320F2810, TMS320F2811, TMS320C2810, and TMS320C2811 128-Pin PBK LQFP (Top View)

2.4 Signal Descriptions

Table 2-2 specifies the signals on the F281x and C281x devices. All digital inputs are TTL-compatible. All outputs are 3.3 V with CMOS levels. Inputs are not 5-V tolerant. A 100- μ A (or 20- μ A) pullup/pulldown is used.

Table 2-2. Signal Descriptions⁽¹⁾

| NAME | PIN NO. | | | I/O/Z ⁽²⁾ | PU/PD ⁽³⁾ | DESCRIPTION |
|----------------------------------|---------------------|----------------|----------------|----------------------|----------------------|--------------------------|
| | 179-BALL GHH/ZHH | 176-PIN PGF | 128-PIN PBK | | | |
| XINTF SIGNALS (2812 ONLY) | | | | | | |
| XA[18] | D7 | 158 | – | O/Z | – | 19-bit XINTF Address Bus |
| XA[17] | B7 | 156 | – | O/Z | – | |
| XA[16] | A8 | 152 | – | O/Z | – | |
| XA[15] | B9 | 148 | – | O/Z | – | |
| XA[14] | A10 | 144 | – | O/Z | – | |
| XA[13] | E10 | 141 | – | O/Z | – | |
| XA[12] | C11 | 138 | – | O/Z | – | |
| XA[11] | A14 | 132 | – | O/Z | – | |
| XA[10] | C12 | 130 | – | O/Z | – | |
| XA[9] | D14 | 125 | – | O/Z | – | |
| XA[8] | E12 | 121 | – | O/Z | – | |
| XA[7] | F12 | 118 | – | O/Z | – | |
| XA[6] | G14 | 111 | – | O/Z | – | |
| XA[5] | H13 | 108 | – | O/Z | – | |
| XA[4] | J12 | 103 | – | O/Z | – | |
| XA[3] | M11 | 85 | – | O/Z | – | |
| XA[2] | N10 | 80 | – | O/Z | – | |
| XA[1] | M2 | 43 | – | O/Z | – | |
| XA[0] | G5 | 18 | – | O/Z | – | |
| XD[15] | A9 | 147 | – | I/O/Z | PU | 16-bit XINTF Data Bus |
| XD[14] | B11 | 139 | – | I/O/Z | PU | |
| XD[13] | J10 | 97 | – | I/O/Z | PU | |
| XD[12] | L14 | 96 | – | I/O/Z | PU | |
| XD[11] | N9 | 74 | – | I/O/Z | PU | |
| XD[10] | L9 | 73 | – | I/O/Z | PU | |
| XD[9] | M8 | 68 | – | I/O/Z | PU | |
| XD[8] | P7 | 65 | – | I/O/Z | PU | |
| XD[7] | L5 | 54 | – | I/O/Z | PU | |
| XD[6] | L3 | 39 | – | I/O/Z | PU | |
| XD[5] | J5 | 36 | – | I/O/Z | PU | |
| XD[4] | K3 | 33 | – | I/O/Z | PU | |
| XD[3] | J3 | 30 | – | I/O/Z | PU | |
| XD[2] | H5 | 27 | – | I/O/Z | PU | |
| XD[1] | H3 | 24 | – | I/O/Z | PU | |
| XD[0] | G3 | 21 | – | I/O/Z | PU | |

(1) Typical drive strength of the output buffer for all pins is 4 mA except for TDO, XCLKOUT, XF, XINTF, EMU0, and EMU1 pins, which are 8 mA.

(2) I = Input, O = Output, Z = High impedance

(3) PU = pin has internal pullup; PD = pin has internal pulldown. Pullup/pulldown strength is given in Section 6.3, Electrical Characteristics Over Recommended Operating Conditions. The pullups/pulldowns are enabled in boundary scan mode.

Table 2-2. Signal Descriptions⁽¹⁾ (continued)

| NAME | PIN NO. | | | I/O/Z ⁽²⁾ | PU/PD ⁽³⁾ | DESCRIPTION |
|-------------------------------|---------------------|----------------|----------------|----------------------|----------------------|---|
| | 179-BALL GHH/ZHH | 176-PIN PGF | 128-PIN PBK | | | |
| XMP/ $\overline{\text{MC}}$ | F1 | 17 | – | I | PD | Microprocessor/Microcomputer Mode Select. Switches between microprocessor and microcomputer mode. When high, Zone 7 is enabled on the external interface. When low, Zone 7 is disabled from the external interface, and on-chip boot ROM may be accessed instead. This signal is latched into the XINTCNF2 register on a reset and the user can modify this bit in software. The state of the XMP/ $\overline{\text{MC}}$ pin is ignored after reset. |
| $\overline{\text{XHOLD}}$ | E7 | 159 | – | I | PU | External Hold Request. $\overline{\text{XHOLD}}$, when active (low), requests the XINTF to release the external bus and place all buses and strobes into a high-impedance state. The XINTF will release the bus when any current access is complete and there are no pending accesses on the XINTF. |
| $\overline{\text{XHOLDA}}$ | K10 | 82 | – | O/Z | – | External Hold Acknowledge. $\overline{\text{XHOLDA}}$ is driven active (low) when the XINTF has granted a $\overline{\text{XHOLD}}$ request. All XINTF buses and strobe signals will be in a high-impedance state. $\overline{\text{XHOLDA}}$ is released when the $\overline{\text{XHOLD}}$ signal is released. External devices should only drive the external bus when $\overline{\text{XHOLDA}}$ is active (low). |
| $\overline{\text{XZCS0AND1}}$ | P1 | 44 | – | O/Z | – | XINTF Zone 0 and Zone 1 Chip Select. $\overline{\text{XZCS0AND1}}$ is active (low) when an access to the XINTF Zone 0 or Zone 1 is performed. |
| $\overline{\text{XZCS2}}$ | P13 | 88 | – | O/Z | – | XINTF Zone 2 Chip Select. $\overline{\text{XZCS2}}$ is active (low) when an access to the XINTF Zone 2 is performed. |
| $\overline{\text{XZCS6AND7}}$ | B13 | 133 | – | O/Z | – | XINTF Zone 6 and Zone 7 Chip Select. $\overline{\text{XZCS6AND7}}$ is active (low) when an access to the XINTF Zone 6 or Zone 7 is performed. |
| $\overline{\text{XWE}}$ | N11 | 84 | – | O/Z | – | Write Enable. Active-low write strobe. The write strobe waveform is specified, per zone basis, by the Lead, Active, and Trail periods in the XTIMINGx registers. |
| $\overline{\text{XRD}}$ | M3 | 42 | – | O/Z | – | Read Enable. Active-low read strobe. The read strobe waveform is specified, per zone basis, by the Lead, Active, and Trail periods in the XTIMINGx registers. NOTE: The $\overline{\text{XRD}}$ and $\overline{\text{XWE}}$ signals are mutually exclusive. |
| XR/ $\overline{\text{W}}$ | N4 | 51 | – | O/Z | – | Read Not Write Strobe. Normally held high. When low, XR/ $\overline{\text{W}}$ indicates write cycle is active; when high, XR/ $\overline{\text{W}}$ indicates read cycle is active. |
| XREADY | B6 | 161 | – | I | PU | Ready Signal. Indicates peripheral is ready to complete the access when asserted to 1. XREADY can be configured to be a synchronous or an asynchronous input. See the timing diagrams for more details. |

Table 2-2. Signal Descriptions⁽¹⁾ (continued)

| NAME | PIN NO. | | | I/O/Z ⁽²⁾ | PU/PD ⁽³⁾ | DESCRIPTION |
|---------------------------------------|---------------------|----------------|----------------|----------------------|----------------------|--|
| | 179-BALL GHH/ZHH | 176-PIN PGF | 128-PIN PBK | | | |
| JTAG AND MISCELLANEOUS SIGNALS | | | | | | |
| X1/XCLKIN | K9 | 77 | 58 | I | – | Oscillator Input – input to the internal oscillator. This pin is also used to feed an external clock. The 28x can be operated with an external clock source, provided that the proper voltage levels be driven on the X1/XCLKIN pin. It should be noted that the X1/XCLKIN pin is referenced to the 1.8-V (or 1.9-V) core digital power supply (V _{DD}), rather than the 3.3-V I/O supply (V _{DDIO}). A clamping diode may be used to clamp a buffered clock signal to ensure that the logic-high level does not exceed V _{DD} (1.8 V or 1.9 V) or a 1.8-V oscillator may be used. |
| X2 | M9 | 76 | 57 | O | – | Oscillator Output |
| XCLKOUT | F11 | 119 | 87 | O | – | Output clock derived from SYSCLKOUT to be used for external wait-state generation and as a general-purpose clock source. XCLKOUT is either the same frequency, 1/2 the frequency, or 1/4 the frequency of SYSCLKOUT. At reset, XCLKOUT = SYSCLKOUT/4. The XCLKOUT signal can be turned off by setting bit 3 (CLKOFF) of the XINTCNF2 register to 1. Unlike other GPIO pins, the XCLKOUT pin is not placed in a high-impedance state during reset. |
| TESTSEL | A13 | 134 | 97 | I | PD | Test Pin. Reserved for TI. Must be connected to ground. |
| $\overline{\text{XRS}}$ | D6 | 160 | 113 | I/O | PU | Device Reset (in) and Watchdog Reset (out). Device reset. $\overline{\text{XRS}}$ causes the device to terminate execution. The PC will point to the address contained at the location 0x3FFFC0. When $\overline{\text{XRS}}$ is brought to a high level, execution begins at the location pointed to by the PC. This pin is driven low by the DSP when a watchdog reset occurs. During watchdog reset, the $\overline{\text{XRS}}$ pin will be driven low for the watchdog reset duration of 512 XCLKIN cycles. The output buffer of this pin is an open-drain with an internal pullup (100 μ A, typical). It is recommended that this pin be driven by an open-drain device. |
| TEST1 | M7 | 67 | 51 | I/O | – | Test Pin. Reserved for TI. On F281x devices, TEST1 must be left unconnected. On C281x devices, this pin is a “no connect (NC)” (that is, this pin is not connected to any circuitry internal to the device). |
| TEST2 | N7 | 66 | 50 | I/O | – | Test Pin. Reserved for TI. On F281x devices, TEST2 must be left unconnected. On C281x devices, this pin is a “no connect (NC)” (that is, this pin is not connected to any circuitry internal to the device). |

Table 2-2. Signal Descriptions⁽¹⁾ (continued)

| NAME | PIN NO. | | | I/O/Z ⁽²⁾ | PU/PD ⁽³⁾ | DESCRIPTION |
|--------------------------|---------------------|----------------|----------------|----------------------|----------------------|---|
| | 179-BALL GHH/ZHH | 176-PIN PGF | 128-PIN PBK | | | |
| JTAG | | | | | | |
| $\overline{\text{TRST}}$ | B12 | 135 | 98 | I | PD | <p>JTAG test reset with internal pulldown. $\overline{\text{TRST}}$, when driven high, gives the scan system control of the operations of the device. If this signal is not connected or driven low, the device operates in its functional mode, and the test reset signals are ignored.</p> <p>NOTE: Do not use pullup resistors on $\overline{\text{TRST}}$; it has an internal pulldown device. $\overline{\text{TRST}}$ is an active-high test pin and must be maintained low at all times during normal device operation. In a low-noise environment, $\overline{\text{TRST}}$ may be left floating. In other instances, an external pulldown resistor is highly recommended. The value of this resistor should be based on drive strength of the debugger pods applicable to the design. A 2.2-kΩ resistor generally offers adequate protection. Since this is application-specific, it is recommended that each target board be validated for proper operation of the debugger and the application.</p> |
| TCK | A12 | 136 | 99 | I | PU | JTAG test clock with internal pullup |
| TMS | D13 | 126 | 92 | I | PU | JTAG test-mode select (TMS) with internal pullup. This serial control input is clocked into the TAP controller on the rising edge of TCK. |
| TDI | C13 | 131 | 96 | I | PU | JTAG test data input (TDI) with internal pullup. TDI is clocked into the selected register (instruction or data) on a rising edge of TCK. |
| TDO | D12 | 127 | 93 | O/Z | – | JTAG scan out, test data output (TDO). The contents of the selected register (instruction or data) is shifted out of TDO on the falling edge of TCK. |
| EMU0 | D11 | 137 | 100 | I/O/Z | PU | <p>Emulator pin 0. When $\overline{\text{TRST}}$ is driven high, this pin is used as an interrupt to or from the emulator system and is defined as input/output through the JTAG scan. This pin is also used to put the device into boundary-scan mode. With the EMU0 pin at a logic-high state and the EMU1 pin at a logic-low state, a rising edge on the $\overline{\text{TRST}}$ pin would latch the device into boundary-scan mode.</p> <p>NOTE: An external pullup resistor is recommended on this pin. The value of this resistor should be based on the drive strength of the debugger pods applicable to the design. A 2.2-kΩ to 4.7-kΩ resistor is generally adequate. Since this is application-specific, it is recommended that each target board be validated for proper operation of the debugger and the application.</p> |

Table 2-2. Signal Descriptions⁽¹⁾ (continued)

| NAME | PIN NO. | | | I/O/Z ⁽²⁾ | PU/PD ⁽³⁾ | DESCRIPTION |
|---------------------------------|---------------------|----------------|----------------|----------------------|----------------------|---|
| | 179-BALL GHH/ZHH | 176-PIN PGF | 128-PIN PBK | | | |
| EMU1 | C9 | 146 | 105 | I/O/Z | PU | <p>Emulator pin 1. When $\overline{\text{TRST}}$ is driven high, this pin is used as an interrupt to or from the emulator system and is defined as input/output through the JTAG scan. This pin is also used to put the device into boundary-scan mode. With the EMU0 pin at a logic-high state and the EMU1 pin at a logic-low state, a rising edge on the $\overline{\text{TRST}}$ pin would latch the device into boundary-scan mode.</p> <p>NOTE: An external pullup resistor is recommended on this pin. The value of this resistor should be based on the drive strength of the debugger pods applicable to the design. A 2.2-kΩ to 4.7-kΩ resistor is generally adequate. Since this is application-specific, it is recommended that each target board be validated for proper operation of the debugger and the application.</p> |
| ADC ANALOG INPUT SIGNALS | | | | | | |
| ADCINA7 | B5 | 167 | 119 | I | – | <p>8-channel analog inputs for Sample-and-Hold A. The ADC pins should not be driven before the V_{DDA1}, V_{DDA2}, and V_{DDAIO} pins have been fully powered up.</p> |
| ADCINA6 | D5 | 168 | 120 | I | – | |
| ADCINA5 | E5 | 169 | 121 | I | – | |
| ADCINA4 | A4 | 170 | 122 | I | – | |
| ADCINA3 | B4 | 171 | 123 | I | – | |
| ADCINA2 | C4 | 172 | 124 | I | – | |
| ADCINA1 | D4 | 173 | 125 | I | – | |
| ADCINA0 | A3 | 174 | 126 | I | – | |
| ADCINB7 | F5 | 9 | 9 | I | – | <p>8-channel analog inputs for Sample-and-Hold B. The ADC pins should not be driven before the V_{DDA1}, V_{DDA2}, and V_{DDAIO} pins have been fully powered up.</p> |
| ADCINB6 | D1 | 8 | 8 | I | – | |
| ADCINB5 | D2 | 7 | 7 | I | – | |
| ADCINB4 | D3 | 6 | 6 | I | – | |
| ADCINB3 | C1 | 5 | 5 | I | – | |
| ADCINB2 | B1 | 4 | 4 | I | – | |
| ADCINB1 | C3 | 3 | 3 | I | – | |
| ADCINB0 | C2 | 2 | 2 | I | – | |
| ADCREFP | E2 | 11 | 11 | I/O | – | <p>ADC Voltage Reference Output (2 V). Requires a low ESR (under 1.5 Ω) ceramic bypass capacitor of 10 μF to analog ground. [Can accept external reference input (2 V) if the software bit is enabled for this mode. 1–10 μF low ESR capacitor can be used in the external reference mode.]</p> <p>NOTE: Use the ADC Clock rate to derive the ESR specification from the capacitor data sheet that is used in the system.</p> |
| ADCREFM | E4 | 10 | 10 | I/O | – | <p>ADC Voltage Reference Output (1 V). Requires a low ESR (under 1.5 Ω) ceramic bypass capacitor of 10 μF to analog ground. [Can accept external reference input (1 V) if the software bit is enabled for this mode. 1–10 μF low ESR capacitor can be used in the external reference mode.]</p> <p>NOTE: Use the ADC Clock rate to derive the ESR specification from the capacitor data sheet that is used in the system.</p> |

Table 2-2. Signal Descriptions⁽¹⁾ (continued)

| NAME | PIN NO. | | | I/O/Z ⁽²⁾ | PU/PD ⁽³⁾ | DESCRIPTION |
|----------------------|---------------------|----------------|----------------|----------------------|----------------------|---|
| | 179-BALL GHH/ZHH | 176-PIN PGF | 128-PIN PBK | | | |
| ADCRESEXT | F2 | 16 | 16 | O | – | ADC External Current Bias Resistor. Use 24.9 kΩ ± 5% for ADC clock range 1–18.75 MHz; use 20 kΩ ± 5% for ADC clock range 18.75 MHz–25 MHz. |
| ADCBGREFIN | E6 | 164 | 116 | – | – | Test Pin. Reserved for TI. Must be left unconnected. |
| AVSSREFBG | E3 | 12 | 12 | – | – | ADC Analog GND |
| AVDDREFBG | E1 | 13 | 13 | – | – | ADC Analog Power (3.3-V) |
| ADCLO | B3 | 175 | 127 | – | – | Common Low Side Analog Input. Connect to analog ground. |
| V _{SSA1} | F3 | 15 | 15 | – | – | ADC Analog GND |
| V _{SSA2} | C5 | 165 | 117 | – | – | ADC Analog GND |
| V _{DDA1} | F4 | 14 | 14 | – | – | ADC Analog 3.3-V Supply |
| V _{DDA2} | A5 | 166 | 118 | – | – | ADC Analog 3.3-V Supply |
| V _{SS1} | C6 | 163 | 115 | – | – | ADC Digital GND |
| V _{DD1} | A6 | 162 | 114 | – | – | ADC Digital 1.8-V (or 1.9-V) Supply |
| V _{DDAIO} | B2 | 1 | 1 | – | – | 3.3-V Analog I/O Power Pin |
| V _{SSAIO} | A2 | 176 | 128 | – | – | Analog I/O Ground Pin |
| POWER SIGNALS | | | | | | |
| V _{DD} | H1 | 23 | 20 | – | – | 1.8-V or 1.9-V Core Digital Power Pins. See Section 6.2 , Recommended Operating Conditions, for voltage requirements. |
| V _{DD} | L1 | 37 | 29 | – | – | |
| V _{DD} | P5 | 56 | 42 | – | – | |
| V _{DD} | P9 | 75 | 56 | – | – | |
| V _{DD} | P12 | – | 63 | – | – | |
| V _{DD} | K12 | 100 | 74 | – | – | |
| V _{DD} | G12 | 112 | 82 | – | – | |
| V _{DD} | C14 | 128 | 94 | – | – | |
| V _{DD} | B10 | 143 | 102 | – | – | |
| V _{DD} | C8 | 154 | 110 | – | – | |
| V _{SS} | G4 | 19 | 17 | – | – | Core and Digital I/O Ground Pins |
| V _{SS} | K1 | 32 | 26 | – | – | |
| V _{SS} | L2 | 38 | 30 | – | – | |
| V _{SS} | P4 | 52 | 39 | – | – | |
| V _{SS} | K6 | 58 | – | – | – | |
| V _{SS} | P8 | 70 | 53 | – | – | |
| V _{SS} | M10 | 78 | 59 | – | – | |
| V _{SS} | L11 | 86 | 62 | – | – | |
| V _{SS} | K13 | 99 | 73 | – | – | |
| V _{SS} | J14 | 105 | – | – | – | |
| V _{SS} | G13 | 113 | – | – | – | |
| V _{SS} | E14 | 120 | 88 | – | – | |
| V _{SS} | B14 | 129 | 95 | – | – | |
| V _{SS} | D10 | 142 | – | – | – | |
| V _{SS} | C10 | – | 103 | – | – | |
| V _{SS} | B8 | 153 | 109 | – | – | |

Table 2-2. Signal Descriptions⁽¹⁾ (continued)

| NAME | PIN NO. | | | I/O/Z ⁽²⁾ | PU/PD ⁽³⁾ | DESCRIPTION |
|-----------------------------------|---------------------|----------------|----------------|----------------------|----------------------|--|
| | 179-BALL GHH/ZHH | 176-PIN PGF | 128-PIN PBK | | | |
| V _{DDIO} | J4 | 31 | 25 | – | – | 3 3-V I/O Digital Power Pins |
| V _{DDIO} | L7 | 64 | 49 | – | – | |
| V _{DDIO} | L10 | 81 | – | – | – | |
| V _{DDIO} | N14 | – | – | – | – | |
| V _{DDIO} | G11 | 114 | 83 | – | – | |
| V _{DDIO} | E9 | 145 | 104 | – | – | |
| V _{DD3VFL} | N8 | 69 | 52 | – | – | 3.3-V Flash Core Power Pin. This pin should be connected to 3.3 V at all times after power-up sequence requirements have been met. This pin is used as V _{DDIO} in ROM parts and must be connected to 3.3 V in ROM parts as well. |
| GPIO OR PERIPHERAL SIGNALS | | | | | | |
| GPIOA OR EVA SIGNALS | | | | | | |
| GPIOA0 - PWM1 (O) | M12 | 92 | 68 | I/O | PU | GPIO or PWM Output Pin #1 |
| GPIOA1 - PWM2 (O) | M14 | 93 | 69 | I/O | PU | GPIO or PWM Output Pin #2 |
| GPIOA2 - PWM3 (O) | L12 | 94 | 70 | I/O | PU | GPIO or PWM Output Pin #3 |
| GPIOA3 - PWM4 (O) | L13 | 95 | 71 | I/O | PU | GPIO or PWM Output Pin #4 |
| GPIOA4 - PWM5 (O) | K11 | 98 | 72 | I/O | PU | GPIO or PWM Output Pin #5 |
| GPIOA5 - PWM6 (O) | K14 | 101 | 75 | I/O | PU | GPIO or PWM Output Pin #6 |
| GPIOA6 - T1PWM_T1CMP (I) | J11 | 102 | 76 | I/O | PU | GPIO or Timer 1 Output |
| GPIOA7 - T2PWM_T2CMP (I) | J13 | 104 | 77 | I/O | PU | GPIO or Timer 2 Output |
| GPIOA8 - CAP1_QEP1 (I) | H10 | 106 | 78 | I/O | PU | GPIO or Capture Input #1 |
| GPIOA9 - CAP2_QEP2 (I) | H11 | 107 | 79 | I/O | PU | GPIO or Capture Input #2 |
| GPIOA10 - CAP3_QEP1 (I) | H12 | 109 | 80 | I/O | PU | GPIO or Capture Input #3 |
| GPIOA11 - TDIRA (I) | F14 | 116 | 85 | I/O | PU | GPIO or Timer Direction |
| GPIOA12 - TCLKINA (I) | F13 | 117 | 86 | I/O | PU | GPIO or Timer Clock Input |
| GPIOA13 - C1TRIP (I) | E13 | 122 | 89 | I/O | PU | GPIO or Compare 1 Output Trip |
| GPIOA14 - C2TRIP (I) | E11 | 123 | 90 | I/O | PU | GPIO or Compare 2 Output Trip |
| GPIOA15 - C3TRIP (I) | F10 | 124 | 91 | I/O | PU | GPIO or Compare 3 Output Trip |
| GPIOB OR EVB SIGNALS | | | | | | |
| GPIOB0 - PWM7 (O) | N2 | 45 | 33 | I/O | PU | GPIO or PWM Output Pin #7 |
| GPIOB1 - PWM8 (O) | P2 | 46 | 34 | I/O | PU | GPIO or PWM Output Pin #8 |
| GPIOB2 - PWM9 (O) | N3 | 47 | 35 | I/O | PU | GPIO or PWM Output Pin #9 |
| GPIOB3 - PWM10 (O) | P3 | 48 | 36 | I/O | PU | GPIO or PWM Output Pin #10 |
| GPIOB4 - PWM11 (O) | L4 | 49 | 37 | I/O | PU | GPIO or PWM Output Pin #11 |
| GPIOB5 - PWM12 (O) | M4 | 50 | 38 | I/O | PU | GPIO or PWM Output Pin #12 |
| GPIOB6 - T3PWM_T3CMP (I) | K5 | 53 | 40 | I/O | PU | GPIO or Timer 3 Output |
| GPIOB7 - T4PWM_T4CMP (I) | N5 | 55 | 41 | I/O | PU | GPIO or Timer 4 Output |
| GPIOB8 - CAP4_QEP3 (I) | M5 | 57 | 43 | I/O | PU | GPIO or Capture Input #4 |
| GPIOB9 - CAP5_QEP4 (I) | M6 | 59 | 44 | I/O | PU | GPIO or Capture Input #5 |
| GPIOB10 - CAP6_QEP1 (I) | P6 | 60 | 45 | I/O | PU | GPIO or Capture Input #6 |
| GPIOB11 - TDIRB (I) | L8 | 71 | 54 | I/O | PU | GPIO or Timer Direction |
| GPIOB12 - TCLKINB (I) | K8 | 72 | 55 | I/O | PU | GPIO or Timer Clock Input |

Table 2-2. Signal Descriptions⁽¹⁾ (continued)

| NAME | PIN NO. | | | I/O/Z ⁽²⁾ | PU/PD ⁽³⁾ | DESCRIPTION |
|--|---------------------|----------------|----------------|----------------------|----------------------|--|
| | 179-BALL GHH/ZHH | 176-PIN PGF | 128-PIN PBK | | | |
| GPIOB13 - $\overline{C4TRIP}$ (I) | N6 | 61 | 46 | I/O | PU | GPIO or Compare 4 Output Trip |
| GPIOB14 - $\overline{C5TRIP}$ (I) | L6 | 62 | 47 | I/O | PU | GPIO or Compare 5 Output Trip |
| GPIOB15 - $\overline{C6TRIP}$ (I) | K7 | 63 | 48 | I/O | PU | GPIO or Compare 6 Output Trip |
| GPIOD OR EVA SIGNALS | | | | | | |
| GPIOD0 - $\overline{T1CTRIP_PDPINTA}$ (I) | H14 | 110 | 81 | I/O | PU | GPIO or Timer 1 Compare Output Trip |
| GPIOD1 - $\overline{T2CTRIP/EVASOC}$ (I) | G10 | 115 | 84 | I/O | PU | GPIO or Timer 2 Compare Output Trip or External ADC Start-of-Conversion EV-A |
| GPIOD OR EVB SIGNALS | | | | | | |
| GPIOD5 - $\overline{T3CTRIP_PDPINTB}$ (I) | P10 | 79 | 60 | I/O | PU | GPIO or Timer 3 Compare Output Trip |
| GPIOD6 - $\overline{T4CTRIP/EVBSOC}$ (I) | P11 | 83 | 61 | I/O | PU | GPIO or Timer 4 Compare Output Trip or External ADC Start-of-Conversion EV-B |
| GPIOE OR INTERRUPT SIGNALS | | | | | | |
| GPIOE0 - XINT1_ \overline{XBIO} (I) | D9 | 149 | 106 | I/O/Z | – | GPIO or XINT1 or \overline{XBIO} input |
| GPIOE1 - XINT2_ADCSOC (I) | D8 | 151 | 108 | I/O/Z | – | GPIO or XINT2 or ADC start-of-conversion |
| GPIOE2 - XNMI_XINT13 (I) | E8 | 150 | 107 | I/O | PU | GPIO or XNMI or XINT13 |
| GPIOF OR SPI SIGNALS | | | | | | |
| GPIOF0 - SPISIMOA (O) | M1 | 40 | 31 | I/O/Z | – | GPIO or SPI slave in, master out |
| GPIOF1 - SPISOMIA (I) | N1 | 41 | 32 | I/O/Z | – | GPIO or SPI slave out, master in |
| GPIOF2 - SPICLKA (I/O) | K2 | 34 | 27 | I/O/Z | – | GPIO or SPI clock |
| GPIOF3 - SPISTEA (I/O) | K4 | 35 | 28 | I/O/Z | – | GPIO or SPI slave transmit enable |
| GPIOF OR SCI-A SIGNALS | | | | | | |
| GPIOF4 - SCITXDA (O) | C7 | 155 | 111 | I/O | PU | GPIO or SCI asynchronous serial port TX data |
| GPIOF5 - SCIRXDA (I) | A7 | 157 | 112 | I/O | PU | GPIO or SCI asynchronous serial port RX data |
| GPIOF OR CAN SIGNALS | | | | | | |
| GPIOF6 - CANTXA (O) | N12 | 87 | 64 | I/O | PU | GPIO or eCAN transmit data |
| GPIOF7 - CANRXA (I) | N13 | 89 | 65 | I/O | PU | GPIO or eCAN receive data |
| GPIOF OR McBSP SIGNALS | | | | | | |
| GPIOF8 - MCLKXA (I/O) | J1 | 28 | 23 | I/O | PU | GPIO or McBSP transmit clock |
| GPIOF9 - MCLKRA (I/O) | H2 | 25 | 21 | I/O | PU | GPIO or McBSP receive clock |
| GPIOF10 - MFSXA (I/O) | H4 | 26 | 22 | I/O | PU | GPIO or McBSP transmit frame synch |
| GPIOF11 - MFSRA (I/O) | J2 | 29 | 24 | I/O | PU | GPIO or McBSP receive frame synch |
| GPIOF12 - MDXA (O) | G1 | 22 | 19 | I/O | – | GPIO or McBSP transmitted serial data |
| GPIOF13 - MDRA (I) | G2 | 20 | 18 | I/O | PU | GPIO or McBSP received serial data |

Table 2-2. Signal Descriptions⁽¹⁾ (continued)

| NAME | PIN NO. | | | I/O/Z ⁽²⁾ | PU/PD ⁽³⁾ | DESCRIPTION |
|--------------------------------------|---------------------|----------------|----------------|----------------------|----------------------|--|
| | 179-BALL GHH/ZHH | 176-PIN PGF | 128-PIN PBK | | | |
| GPIOF OR XF CPU OUTPUT SIGNAL | | | | | | |
| GPIOF14 - XF_XPLLDIS (O) | A11 | 140 | 101 | I/O | PU | This pin has three functions: <ol style="list-style-type: none"> 1. XF – General-purpose output pin. 2. XPLLDIS – This pin is sampled during reset to check whether the PLL must be disabled. The PLL will be disabled if this pin is sensed low. HALT and STANDBY modes cannot be used when the PLL is disabled. 3. GPIO – GPIO function |
| GPIOG OR SCI-B SIGNALS | | | | | | |
| GPIOG4 - SCITXDB (O) | P14 | 90 | 66 | I/O/Z | – | GPIO or SCI asynchronous serial port transmit data |
| GPIOG5 - SCIRXDB (I) | M13 | 91 | 67 | I/O/Z | – | GPIO or SCI asynchronous serial port receive data |

NOTE

Other than the power supply pins, no pin should be driven before the 3.3-V rail has reached recommended operating conditions. However, it is acceptable for an I/O pin to ramp along with the 3.3-V supply.

3 Functional Overview

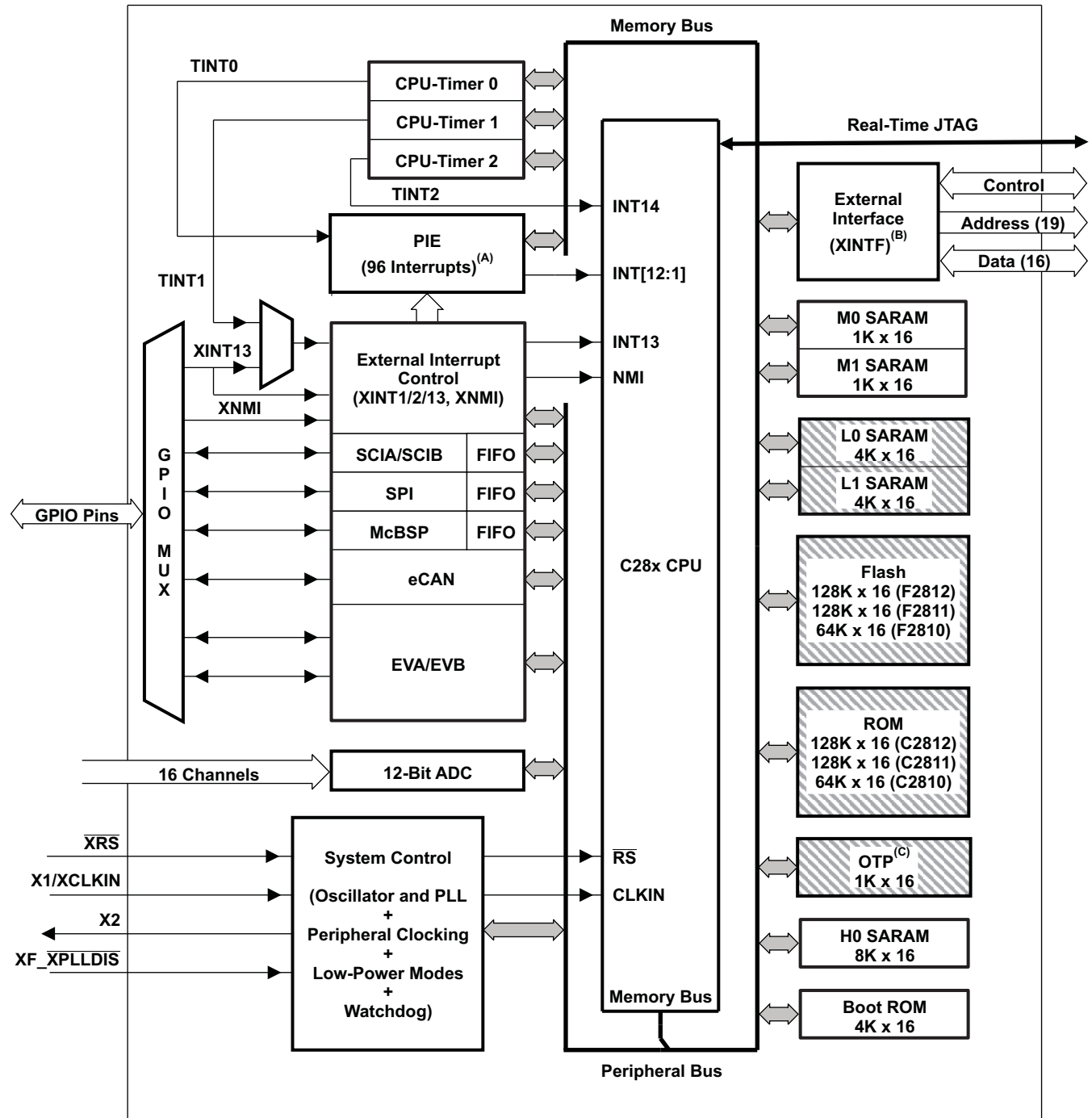

 Protected by the code-security module.

- A. 45 of the possible 96 interrupts are used on the devices.
- B. XINTF is available on the F2812 and C2812 devices only.
- C. On C281x devices, the OTP is replaced with a 1K x 16 block of ROM.

Figure 3-1. Functional Block Diagram

3.1 Memory Map

| Block Start Address | On-Chip Memory | | External Memory XINTF | | | | |
|---|--|---|-----------------------|------------|--|---|-----------|
| | Data Space | Prog Space | Data Space | Prog Space | | | |
| Low 64K (24x/240x Equivalent Data Space) | 0x00 0000 | M0 Vector - RAM (32 x 32) (Enabled if VMAP = 0) | Reserved | Reserved | | | |
| | 0x00 0040 | M0 SARAM (1K x 16) | | | | | |
| | 0x00 0400 | M1 SARAM (1K x 16) | | | | | |
| | 0x00 0800 | Peripheral Frame 0 | | | | | |
| | 0x00 0D00 | PIE Vector - RAM (256 x 16) (Enabled if VMAP = 1, ENPIE = 1) | | | | | |
| | 0x00 0E00 | Reserved | | | | | |
| | 0x00 2000 | Reserved | | | XINTF Zone 0 (8K x 16, $\overline{XZCS0AND1}$) | 0x00 2000 | |
| | 0x00 6000 | Peripheral Frame 1 (Protected) | | | XINTF Zone 1 (8K x 16, $\overline{XZCS0AND1}$) (Protected) | 0x00 4000 | |
| | 0x00 7000 | Peripheral Frame 2 (Protected) | | | Reserved | Reserved | |
| | 0x00 8000 | L0 SARAM (4K x 16, Secure Block) | | | | | |
| | 0x00 9000 | L1 SARAM (4K x 16, Secure Block) | | | | | |
| | 0x00 A000 | Reserved | | | | | |
| | High 64K (24x/240x Equivalent Program Space) | 0x08 0000 | | | Reserved | XINTF Zone 2 (0.5M x 16, $\overline{XZCS2}$) | 0x08 0000 |
| | | 0x10 0000 | | | Reserved | XINTF Zone 6 (0.5M x 16, $\overline{XZCS6AND7}$) | 0x10 0000 |
| 0x18 0000 | | Reserved | Reserved | Reserved | | | |
| 0x3D 7800 | | OTP (or ROM) (1K x 16, Secure Block) | | | | | |
| 0x3D 7C00 | | Reserved (1K) | | | | | |
| 0x3D 8000 | | Flash (or ROM) (128K x 16, Secure Block) | | | | | |
| 0x3F 7FF8 | | 128-Bit Password | | | | | |
| 0x3F 8000 | | H0 SARAM (8K x 16) | | | | | |
| 0x3F A000 | | Reserved | | | | | |
| 0x3F F000 | | Boot ROM (4K x 16) (Enabled if MP/MC = 0) | | | XINTF Zone 7 (16K x 16, $\overline{XZCS6AND7}$) (Enabled if MP/MC = 1) | 0x3F C000 | |
| 0x3F FFC0 | BROM Vector - ROM (32 x 32) (Enabled if VMAP = 1, MP/MC = 0, ENPIE = 0) | XINTF Vector - RAM (32 x 32) (Enabled if VMAP = 1, MP/MC = 1, ENPIE = 0) | | | | | |

LEGEND:

 Only one of these vector maps - M0 vector, PIE vector, BROM vector, XINTF vector - should be enabled at a time.

- A. Memory blocks are not to scale.
- B. Reserved locations are reserved for future expansion. Application should not access these areas.
- C. Boot ROM and Zone 7 memory maps are active either in on-chip or XINTF zone depending on MP/MC, not in both.
- D. Peripheral Frame 0, Peripheral Frame 1, and Peripheral Frame 2 memory maps are restricted to data memory only. User program cannot access these memory maps in program space.
- E. "Protected" means the order of Write followed by Read operations is preserved rather than the pipeline order.
- F. Certain memory ranges are EALLOW protected against spurious writes after configuration.
- G. Zones 0 and 1 and Zones 6 and 7 share the same chip select; hence, these memory blocks have mirrored locations.

Figure 3-2. F2812/C2812 Memory Map

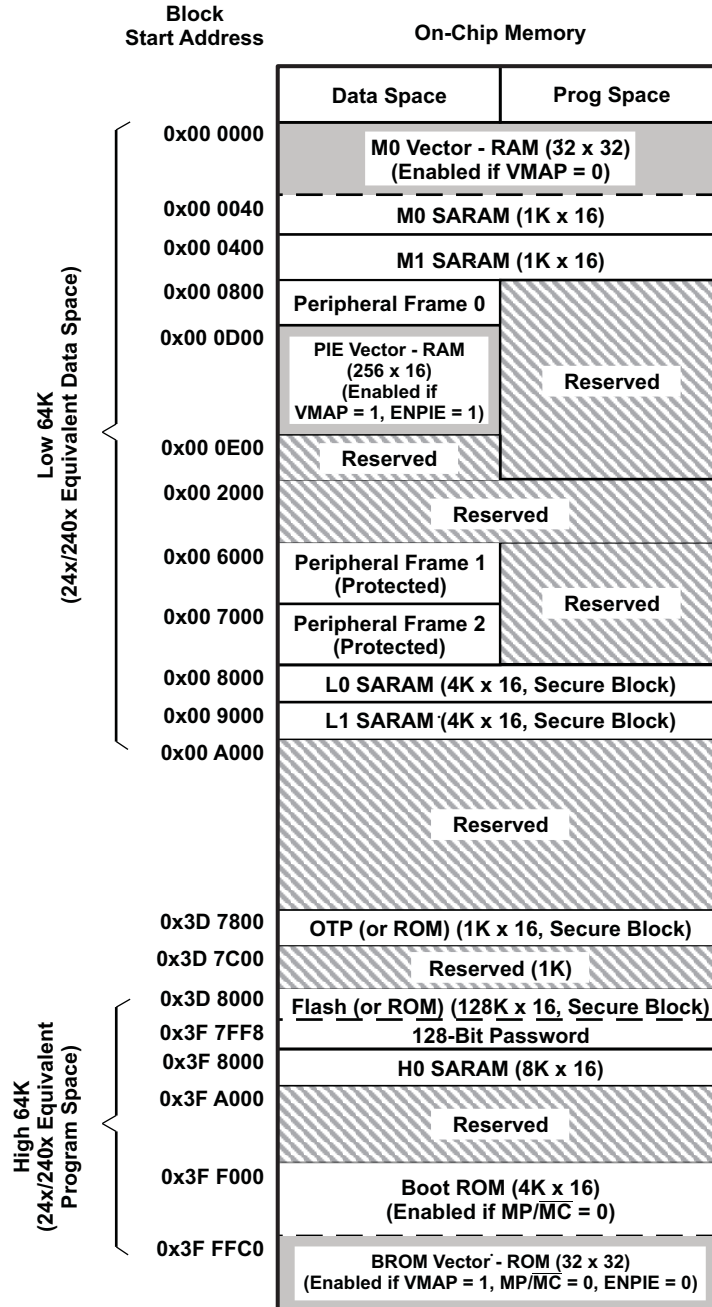

LEGEND:

 Only one of these vector maps - M0 vector, PIE vector, BROM vector - should be enabled at a time.

- A. Memory blocks are not to scale.
- B. Reserved locations are reserved for future expansion. Application should not access these areas.
- C. Peripheral Frame 0, Peripheral Frame 1, and Peripheral Frame 2 memory maps are restricted to data memory only. User program cannot access these memory maps in program space.
- D. "Protected" means the order of Write followed by Read operations is preserved rather than the pipeline order.
- E. Certain memory ranges are EALLOW protected against spurious writes after configuration.

Figure 3-3. F2811/C2811 Memory Map

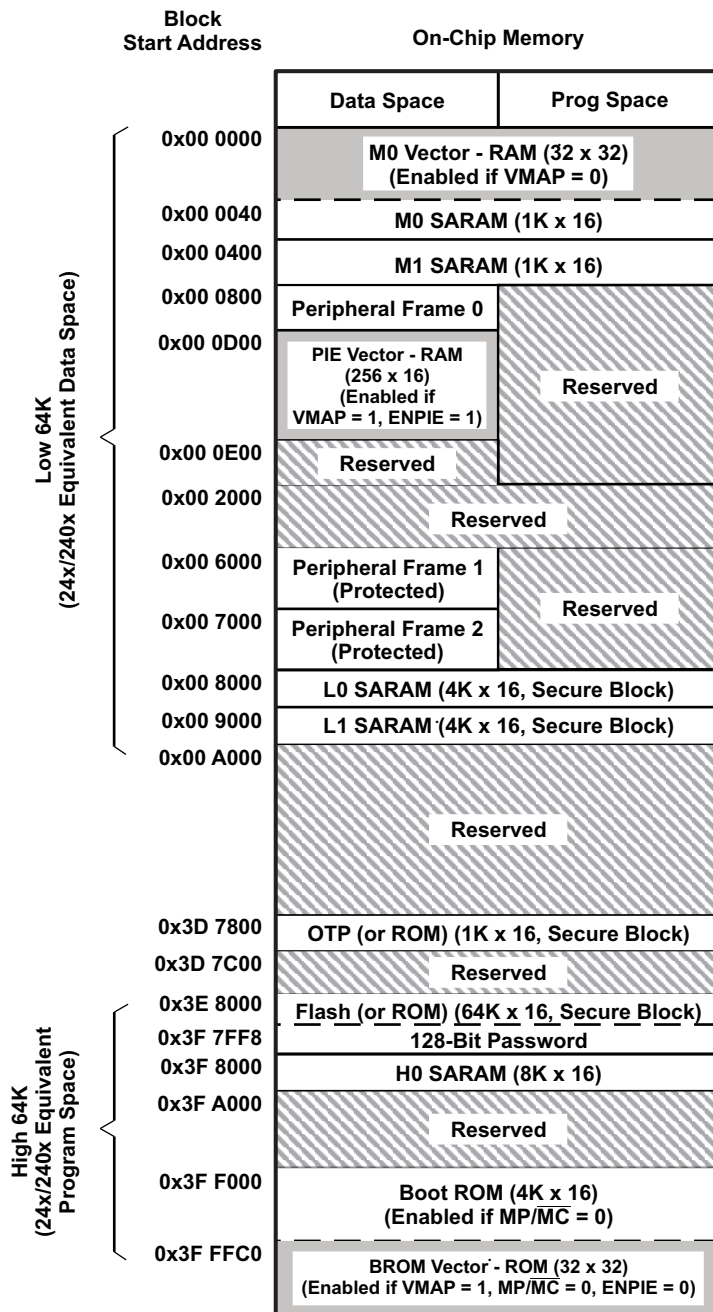

LEGEND:

 Only one of these vector maps - M0 vector, PIE vector, BROM vector - should be enabled at a time.

- A. Memory blocks are not to scale.
- B. Reserved locations are reserved for future expansion. Application should not access these areas.
- C. Peripheral Frame 0, Peripheral Frame 1, and Peripheral Frame 2 memory maps are restricted to data memory only. User program cannot access these memory maps in program space.
- D. "Protected" means the order of Write followed by Read operations is preserved rather than the pipeline order.
- E. Certain memory ranges are EALLOW protected against spurious writes after configuration.

Figure 3-4. F2810/C2810 Memory Map

Table 3-1. Addresses of Flash Sectors in F2812 and F2811

| ADDRESS RANGE | PROGRAM AND DATA SPACE |
|---|---|
| 0x3D 8000 0x3D 9FFF | Sector J, 8K x 16 |
| 0x3D A000 0x3D BFFF | Sector I, 8K x 16 |
| 0x3D C000 0x3D FFFF | Sector H, 16K x 16 |
| 0x3E 0000 0x3E 3FFF | Sector G, 16K x 16 |
| 0x3E 4000 0x3E 7FFF | Sector F, 16K x 16 |
| 0x3E 8000 0x3E BFFF | Sector E, 16K x 16 |
| 0x3E C000 0x3E FFFF | Sector D, 16K x 16 |
| 0x3F 0000 0x3F 3FFF | Sector C, 16K x 16 |
| 0x3F 4000 0x3F 5FFF | Sector B, 8K x 16 |
| 0x3F 6000 0x3F 7F80 0x3F 7FF5 0x3F 7FF6 0x3F 7FF7 0x3F 7FF8 0x3F 7FFF | Sector A, 8K x 16 Program to 0x0000 when using the Code Security Module Boot-to-Flash (or ROM) Entry Point (program branch instruction here) Security Password (128-Bit) (Do not program to all zeros) |

Table 3-2. Addresses of Flash Sectors in F2810

| ADDRESS RANGE | PROGRAM AND DATA SPACE |
|---|---|
| 0x3E 8000 0x3E BFFF | Sector E, 16K x 16 |
| 0x3E C000 0x3E FFFF | Sector D, 16K x 16 |
| 0x3F 0000 0x3F 3FFF | Sector C, 16K x 16 |
| 0x3F 4000 0x3F 5FFF | Sector B, 8K x 16 |
| 0x3F 6000 0x3F 7F80 0x3F 7FF5 0x3F 7FF6 0x3F 7FF7 0x3F 7FF8 0x3F 7FFF | Sector A, 8K x 16 Program to 0x0000 when using the Code Security Module Boot-to-Flash (or ROM) Entry Point (program branch instruction here) Security Password (128-Bit) (Do not program to all zeros) |

The “Low 64K” of the memory address range maps into the data space of the 240x. The “High 64K” of the memory address range maps into the program space of the 24x/240x. 24x/240x-compatible code will execute only from the “High 64K” memory area. Hence, the top 32K of Flash/ROM and H0 SARAM block can be used to run 24x/240x-compatible code (if MP/MC mode is low) or, on the 2812, code can be executed from XINTF Zone 7 (if MP/MC mode is high).

The XINTF consists of five independent zones. One zone has its own chip select and the remaining four zones share two chip selects. Each zone can be programmed with its own timing (wait states) and to either sample or ignore external ready signal. This makes interfacing to external peripherals easy and glueless.

NOTE

The chip selects of XINTF Zone 0 and Zone 1 are merged into a single chip select (XZCS0AND1); and the chip selects of XINTF Zone 6 and Zone 7 are merged into a single chip select (XZCS6AND7). See [Section 3.5](#), External Interface, XINTF (2812 only), for details.

Peripheral Frame 1, Peripheral Frame 2, and XINTF Zone 1 are grouped together to enable these blocks to be “write/read peripheral block protected”. The “protected” mode ensures that all accesses to these blocks happen as written. Because of the C28x pipeline, a write immediately followed by a read, to different memory locations, will appear in reverse order on the memory bus of the CPU. This can cause problems in certain peripheral applications where the user expected the write to occur first (as written). The C28x CPU supports a block protection mode where a region of memory can be protected to make sure that operations occur as written (the penalty is extra cycles that are added to align the operations). This mode is programmable and, by default, it will protect the selected zones.

On the 2812, at reset, XINTF Zone 7 is accessed if the XMP/ \overline{MC} pin is pulled high. This signal selects microprocessor or microcomputer mode of operation. In microprocessor mode, Zone 7 is mapped to high memory such that the vector table is fetched externally. The Boot ROM is disabled in this mode. In microcomputer mode, Zone 7 is disabled such that the vectors are fetched from Boot ROM. This allows the user to either boot from on-chip memory or from off-chip memory. The state of the XMP/ \overline{MC} signal on reset is stored in an MP/ \overline{MC} mode bit in the XINTCNF2 register. The user can change this mode in software and hence control the mapping of Boot ROM and XINTF Zone 7. No other memory blocks are affected by XMP/ \overline{MC} .

I/O space is not supported on the 2812 XINTF.

The wait states for the various spaces in the memory map area are listed in [Table 3-3](#).

Table 3-3. Wait States

| AREA | WAIT-STATES | COMMENTS |
|--------------------|-----------------------------------|---|
| M0 and M1 SARAMs | 0-wait | Fixed |
| Peripheral Frame 0 | 0-wait | Fixed |
| Peripheral Frame 1 | 0-wait (writes) 2-wait (reads) | Fixed |
| Peripheral Frame 2 | 0-wait (writes) 2-wait (reads) | Fixed |
| L0 and L1 SARAMs | 0-wait | Fixed |
| OTP (or ROM) | Programmable, 1-wait minimum | Programmed via the Flash registers. 1-wait-state operation is possible at a reduced CPU frequency. See Section 3.2.6 , Flash (F281x Only), for more information. |
| Flash (or ROM) | Programmable, 0-wait minimum | Programmed via the Flash registers. 0-wait-state operation is possible at reduced CPU frequency. The CSM password locations are hardwired for 16 wait states. See Section 3.2.6 , Flash (F281x Only), for more information. |
| H0 SARAM | 0-wait | Fixed |
| Boot-ROM | 1-wait | Fixed |
| XINTF | Programmable, 1-wait minimum | Programmed via the XINTF registers. Cycles can be extended by external memory or peripheral. 0-wait operation is not possible. |

3.2 Brief Descriptions

3.2.1 C28x CPU

The C28x™ DSP generation is the newest member of the TMS320C2000™ DSP platform. The C28x is source code compatible to the 24x/240x DSP devices, hence existing 240x users can leverage their significant software investment. Additionally, the C28x is a very efficient C/C++ engine, enabling users to develop not only their system control software in a high-level language, but also enables math algorithms to be developed using C/C++. The C28x is as efficient in DSP math tasks as it is in system control tasks that typically are handled by microcontroller devices. This efficiency removes the need for a second processor in many systems. The 32 x 32-bit MAC capabilities of the C28x and its 64-bit processing capabilities, enable the C28x to efficiently handle higher numerical resolution problems that would otherwise demand a more expensive floating-point processor solution. Add to this the fast interrupt response with automatic context save of critical registers, resulting in a device that is capable of servicing many asynchronous events with minimal latency. The C28x has an 8-level-deep protected pipeline with pipelined memory accesses. This pipelining enables the C28x to execute at high speeds without resorting to expensive high-speed memories. Special branch-look-ahead hardware minimizes the latency for conditional discontinuities. Special store conditional operations further improve performance.

3.2.2 Memory Bus (Harvard Bus Architecture)

As with many DSP type devices, multiple busses are used to move data between the memories and peripherals and the CPU. The C28x memory bus architecture contains a program read bus, data read bus and data write bus. The program read bus consists of 22 address lines and 32 data lines. The data read and write busses consist of 32 address lines and 32 data lines each. The 32-bit-wide data busses enable single cycle 32-bit operations. The multiple bus architecture, commonly termed “Harvard Bus”, enables the C28x to fetch an instruction, read a data value and write a data value in a single cycle. All peripherals and memories attached to the memory bus will prioritize memory accesses. Generally, the priority of Memory Bus accesses can be summarized as follows:

- Highest:** Data Writes (Simultaneous data and program writes cannot occur on the memory bus.)
 - Program Writes (Simultaneous data and program writes cannot occur on the memory bus.)
 - Data Reads
 - Program Reads (Simultaneous program reads and fetches cannot occur on the memory bus.)
- Lowest:** Fetches (Simultaneous program reads and fetches cannot occur on the memory bus.)

3.2.3 Peripheral Bus

To enable migration of peripherals between various Texas Instruments (TI™) DSP family of devices, the F281x and C281x adopt a peripheral bus standard for peripheral interconnect. The peripheral bus bridge multiplexes the various busses that make up the processor “Memory Bus” into a single bus consisting of 16 address lines and 16 or 32 data lines and associated control signals. Two versions of the peripheral bus are supported on the F281x and C281x. One version only supports 16-bit accesses (called peripheral frame 2) and this retains compatibility with C240x-compatible peripherals. The other version supports both 16- and 32-bit accesses (called peripheral frame 1).

3.2.4 Real-Time JTAG and Analysis

The F281x and C281x implement the standard IEEE 1149.1 JTAG interface. Additionally, the F281x and C281x support real-time mode of operation whereby the contents of memory, peripheral, and register locations can be modified while the processor is running and executing code and servicing interrupts. The user can also single step through non-time critical code while enabling time-critical interrupts to be serviced without interference. The F281x and C281x implement the real-time mode in hardware within the CPU. This is a unique feature to the F281x and C281x, no software monitor is required. Additionally, special analysis hardware is provided that allows the user to set hardware breakpoint or data/address watch-points and generate various user selectable break events when a match occurs.

3.2.5 External Interface (XINTF) (2812 Only)

This asynchronous interface consists of 19 address lines, 16 data lines, and three chip-select lines. The chip-select lines are mapped to five external zones, Zones 0, 1, 2, 6, and 7. Zones 0 and 1 share a single chip-select; Zones 6 and 7 also share a single chip-select. Each of the five zones can be programmed with a different number of wait states, strobe signal setup and hold timing and each zone can be programmed for extending wait states externally or not. The programmable wait-state, chip-select and programmable strobe timing enables glueless interface to external memories and peripherals.

3.2.6 Flash (F281x Only)

The F2812 and F2811 contain 128K x 16 of embedded flash memory, segregated into four 8K x 16 sectors, and six 16K x 16 sectors. The F2810 has 64K x 16 of embedded flash, segregated into two 8K x 16 sectors, and three 16K x 16 sectors. All three devices also contain a single 1K x 16 of OTP memory at address range 0x3D 7800–0x3D 7BFF. The user can individually erase, program, and validate a flash sector while leaving other sectors untouched. However, it is not possible to use one sector of the flash or the OTP to execute flash algorithms that erase/program other sectors. Special memory pipelining is provided to enable the flash module to achieve higher performance. The flash/OTP is mapped to both program and data space; therefore, it can be used to execute code or store data information.

NOTE

The F2810/F2811/F2812 Flash and OTP wait states can be configured by the application. This allows applications running at slower frequencies to configure the flash to use fewer wait states.

Flash effective performance can be improved by enabling the flash pipeline mode in the Flash options register. With this mode enabled, effective performance of linear code execution will be much faster than the raw performance indicated by the wait state configuration alone. The exact performance gain when using the Flash pipeline mode is application-dependent.

For more information on the Flash options, Flash wait-state, and OTP wait-state registers, see the *TMS320x281x DSP System Control and Interrupts Reference Guide* (literature number [SPRU078](#)).

3.2.7 ROM (C281x Only)

The C2812 and C2811 contain 128K x 16 of ROM. The C2810 has 64K x 16 of ROM. In addition to this, there is a 1K x 16 ROM block that replaces the OTP memory available in flash devices. For information on how to submit ROM codes to TI, see the *TMS320C28x CPU and Instruction Set Reference Guide* (literature number [SPRU430](#)).

3.2.8 M0, M1 SARAMs

All C28x devices contain these two blocks of single access memory, each 1K x 16 in size. The stack pointer points to the beginning of block M1 on reset. The M0 block overlaps the 240x device B0, B1, B2 RAM blocks and hence the mapping of data variables on the 240x devices can remain at the same physical address on C28x devices. The M0 and M1 blocks, like all other memory blocks on C28x devices, are mapped to both program and data space. Hence, the user can use M0 and M1 to execute code or for data variables. The partitioning is performed within the linker. The C28x device presents a unified memory map to the programmer. This makes for easier programming in high-level languages.

3.2.9 L0, L1, H0 SARAMs

The F281x and C281x contain an additional 16K x 16 of single-access RAM, divided into three blocks (4K + 4K + 8K). Each block can be independently accessed hence minimizing pipeline stalls. Each block is mapped to both program and data space.

3.2.10 Boot ROM

The Boot ROM is factory-programmed with boot-loading software. The Boot ROM program executes after device reset and checks several GPIO pins to determine which boot mode to enter. For example, the user can select to execute code already present in the internal Flash or download new software to internal RAM through one of several serial ports. Other boot modes exist as well. The Boot ROM also contains standard tables, such as SIN/COS waveforms, for use in math-related algorithms. [Table 3-4](#) shows the details of how various boot modes may be invoked. See the *TMS320x281x DSP Boot ROM Reference Guide* (literature number [SPRU095](#)), for more information.

Table 3-4. Boot Mode Selection⁽¹⁾⁽²⁾

| BOOT MODE SELECTED | GPIOF4 (SCITXDA) | GPIOF12 (MDXA) | GPIOF3 (SPISTEA) | GPIOF2 (SPICLK) |
|--|------------------|----------------|------------------|-----------------|
| GPIO PU status ⁽³⁾ | PU | No PU | No PU | No PU |
| Jump to Flash/ROM address 0x3F 7FF6. A branch instruction must have been programmed here prior to reset to re-direct code execution as desired. | 1 | x | x | x |
| Call SPI_Boot to load from an external serial SPI EEPROM | 0 | 1 | x | x |
| Call SCI_Boot to load from SCI-A | 0 | 0 | 1 | 1 |
| Jump to H0 SARAM address 0x3F 8000 | 0 | 0 | 1 | 0 |
| Jump to OTP address 0x3D 7800 | 0 | 0 | 0 | 1 |
| Call Parallel_Boot to load from GPIO Port B | 0 | 0 | 0 | 0 |

- (1) Extra care must be taken due to any effect toggling SPICLK to select a boot mode may have on external logic.
- (2) If the boot mode selected is Flash, H0, or OTP, then no external code is loaded by the bootloader.
- (3) PU = pin has an internal pullup. No PU = pin does not have an internal pullup.

3.2.11 Security

The F281x and C281x support high levels of security to protect the user firmware from being reverse-engineered. The security features a 128-bit password (hardcoded for 16 wait states), which the user programs into the flash. One code security module (CSM) is used to protect the flash/ROM/OTP and the L0/L1 SARAM blocks. The security feature prevents unauthorized users from examining the memory contents via the JTAG port, executing code from external memory or trying to boot-load some undesirable software that would export the secure memory contents. To enable access to the secure blocks, the user must write the correct 128-bit "KEY" value, which matches the value stored in the password locations within the Flash/ROM.

NOTE

- When the code-security passwords are programmed, all addresses between 0x3F 7F80 and 0x3F 7FF5 cannot be used as program code or data. These locations must be programmed to 0x0000.
- If the code security feature is not used, addresses 0x3F 7F80 through 0x3F 7FEF may be used for code or data.
- On ROM devices, addresses 0x3F 7FF2–0x3F 7FF5 and 0x3D 7BFC–0x3D 7BFF are reserved for TI, irrespective of whether code security has been used or not. User application should not use these locations in any way.
- The 128-bit password (at 0x3F 7FF8–0x3F 7FFF) must not be programmed to zeros. Doing so would permanently lock the device.

Table 3-5. Impact of Using the Code Security Module

| ADDRESS | CODE SECURITY STATUS | |
|-----------------------|---------------------------|--|
| | Code Security Enabled | Code Security Disabled |
| 0x3F 7F80 – 0x3F 7FEF | Fill with 0x0000 | Application code and data ⁽¹⁾ |
| 0x3F 7FF0 – 0x3F 7FF5 | | |
| 0x3D 7BFC – 0x3D 7BFF | Application code and data | |

(1) See the *TMS320F2810*, *TMS320F2811*, *TMS320F2812*, *TMS320C2810*, *TMS320C2811*, *TMS320C2812* DSP Silicon Errata (literature number [SPRZ193](#)) for some restrictions.

Disclaimer

Code Security Module Disclaimer

THE CODE SECURITY MODULE (CSM) INCLUDED ON THIS DEVICE WAS DESIGNED TO PASSWORD PROTECT THE DATA STORED IN THE ASSOCIATED MEMORY (EITHER ROM OR FLASH) AND IS WARRANTED BY TEXAS INSTRUMENTS (TI), IN ACCORDANCE WITH ITS STANDARD TERMS AND CONDITIONS, TO CONFORM TO TI'S PUBLISHED SPECIFICATIONS FOR THE WARRANTY PERIOD APPLICABLE FOR THIS DEVICE.

TI DOES NOT, HOWEVER, WARRANT OR REPRESENT THAT THE CSM CANNOT BE COMPROMISED OR BREACHED OR THAT THE DATA STORED IN THE ASSOCIATED MEMORY CANNOT BE ACCESSED THROUGH OTHER MEANS. MOREOVER, EXCEPT AS SET FORTH ABOVE, TI MAKES NO WARRANTIES OR REPRESENTATIONS CONCERNING THE CSM OR OPERATION OF THIS DEVICE, INCLUDING ANY IMPLIED WARRANTIES OF MERCHANT ABILITY OR FITNESS FOR A PARTICULAR PURPOSE.

IN NO EVENT SHALL TI BE LIABLE FOR ANY CONSEQUENTIAL, SPECIAL, INDIRECT, INCIDENTAL, OR PUNITIVE DAMAGES, HOWEVER CAUSED, ARISING IN ANY WAY OUT OF YOUR USE OF THE CSM OR THIS DEVICE, WHETHER OR NOT TI HAS BEEN ADVISED OF THE POSSIBILITY OF SUCH DAMAGES. EXCLUDED DAMAGES INCLUDE, BUT ARE NOT LIMITED TO LOSS OF DATA, LOSS OF GOODWILL, LOSS OF USE OR INTERRUPTION OF BUSINESS OR OTHER ECONOMIC LOSS.

3.2.12 Peripheral Interrupt Expansion (PIE) Block

The PIE block serves to multiplex numerous interrupt sources into a smaller set of interrupt inputs. The PIE block can support up to 96 peripheral interrupts. On the F281x and C281x, 45 of the possible 96 interrupts are used by peripherals. The 96 interrupts are grouped into blocks of 8 and each group is fed into 1 of 12 CPU interrupt lines (INT1 to INT12). Each of the 96 interrupts is supported by its own vector stored in a dedicated RAM block that can be overwritten by the user. The vector is automatically fetched by the CPU on servicing the interrupt. It takes 8 CPU clock cycles to fetch the vector and save critical CPU registers. Hence the CPU can quickly respond to interrupt events. Prioritization of interrupts is controlled in hardware and software. Each individual interrupt can be enabled/disabled within the PIE block.

3.2.13 External Interrupts (XINT1, XINT2, XINT13, XNMI)

The F281x and C281x support three masked external interrupts (XINT1, 2, 13). XINT13 is combined with one non-masked external interrupt (XNMI). The combined signal name is XNMI_XINT13. Each of the interrupts can be selected for negative or positive edge triggering and can also be enabled/disabled (including the XNMI). The masked interrupts also contain a 16-bit free-running up-counter, which is reset to zero when a valid interrupt edge is detected. This counter can be used to accurately time-stamp the interrupt.

3.2.14 Oscillator and PLL

The F281x and C281x can be clocked by an external oscillator or by a crystal attached to the on-chip oscillator circuit. A PLL is provided supporting up to 10-input clock-scaling ratios. The PLL ratios can be changed on-the-fly in software, enabling the user to scale back on operating frequency if lower power operation is desired. Refer to [Section 6](#), Electrical Specifications, for timing details. The PLL block can be set in bypass mode.

3.2.15 Watchdog

The F281x and C281x support a watchdog timer. The user software must regularly reset the watchdog counter within a certain time frame; otherwise, the watchdog will generate a reset to the processor. The watchdog can be disabled if necessary.

3.2.16 Peripheral Clocking

The clocks to each individual peripheral can be enabled/disabled to reduce power consumption when a peripheral is not in use. Additionally, the system clock to the serial ports (except eCAN) and the event managers, CAP and QEP blocks can be scaled relative to the CPU clock. This enables the timing of peripherals to be decoupled from increasing CPU clock speeds.

3.2.17 Low-Power Modes

The F281x and C281x devices are fully static CMOS devices. Three low-power modes are provided:

- IDLE:** Place CPU in low-power mode. Peripheral clocks may be turned off selectively and only those peripherals that must function during IDLE are left operating. An enabled interrupt from an active peripheral will wake the processor from IDLE mode.
- STANDBY:** Turns off clock to CPU and peripherals. This mode leaves the oscillator and PLL functional. An external interrupt event will wake the processor and the peripherals. Execution begins on the next valid cycle after detection of the interrupt event.
- HALT:** Turns off the internal oscillator. This mode basically shuts down the device and places it in the lowest possible power consumption mode. Only a reset or XNMI can wake the device from this mode.

3.2.18 Peripheral Frames 0, 1, 2 (PFn)

The F281x and C281x segregate peripherals into three sections. The mapping of peripherals is as follows:

| | | |
|-------------|-------------|---|
| PF0: | XINTF: | External Interface Configuration Registers (2812 only) |
| | PIE: | PIE Interrupt Enable and Control Registers Plus PIE Vector Table |
| | Flash: | Flash Control, Programming, Erase, Verify Registers |
| | Timers: | CPU-Timers 0, 1, 2 Registers |
| | CSM: | Code Security Module KEY Registers |
| PF1: | eCAN: | eCAN Mailbox and Control Registers |
| | PF2: | |
| | SYS: | System Control Registers |
| | GPIO: | GPIO Mux Configuration and Control Registers |
| | EV: | Event Manager (EVA/EVB) Control Registers |
| | McBSP: | McBSP Control and TX/RX Registers |
| | SCI: | Serial Communications Interface (SCI) Control and RX/TX Registers |
| | SPI: | Serial Peripheral Interface (SPI) Control and RX/TX Registers |
| | ADC: | 12-Bit ADC Registers |

3.2.19 General-Purpose Input/Output (GPIO) Multiplexer

Most of the peripheral signals are multiplexed with general-purpose I/O (GPIO) signals. This multiplexing enables use of a pin as GPIO if the peripheral signal or function is not used. On reset, all GPIO pins are configured as inputs. The user can then individually program each pin for GPIO mode or peripheral signal mode. For specific inputs, the user can also select the number of input qualification cycles to filter unwanted noise glitches.

3.2.20 32-Bit CPU-Timers (0, 1, 2)

CPU-Timers 0, 1, and 2 are identical 32-bit timers with presetable periods and with 16-bit clock prescaling. The timers have a 32-bit count-down register, which generates an interrupt when the counter reaches zero. The counter is decremented at the CPU clock speed divided by the prescale value setting. When the counter reaches zero, it is automatically reloaded with a 32-bit period value. CPU-Timer 2 is reserved for the DSP/BIOS Real-Time OS, and is connected to INT14 of the CPU. If DSP/BIOS is not being used, CPU-Timer 2 is available for general use. CPU-Timer 1 is for general use and can be connected to INT13 of the CPU. CPU-Timer 0 is also for general use and is connected to the PIE block.

3.2.21 Control Peripherals

The F281x and C281x support the following peripherals that are used for embedded control and communication:

| | |
|-------------|--|
| EV: | The event manager module includes general-purpose timers, full-compare/PWM units, capture inputs (CAP) and quadrature-encoder pulse (QEP) circuits. Two such event managers are provided which enable two three-phase motors to be driven or four two-phase motors. The event managers on the F281x and C281x are compatible to the event managers on the 240x devices (with some minor enhancements). |
| ADC: | The ADC block is a 12-bit converter, single ended, 16-channels. It contains two sample-and-hold units for simultaneous sampling. |

3.2.22 Serial Port Peripherals

The F281x and C281x support the following serial communication peripherals:

- eCAN:** This is the enhanced version of the CAN peripheral. It supports 32 mailboxes, time stamping of messages, and is CAN 2.0B-compliant.
- McBSP:** The multichannel buffered serial port (McBSP) connects to E1/T1 lines, phone-quality codecs for modem applications or high-quality stereo audio DAC devices. The McBSP receive and transmit registers are supported by a 16-level FIFO that significantly reduces the overhead for servicing this peripheral.
- SPI:** The SPI is a high-speed, synchronous serial I/O port that allows a serial bit stream of programmed length (one to sixteen bits) to be shifted into and out of the device at a programmable bit-transfer rate. Normally, the SPI is used for communications between the DSP controller and external peripherals or another processor. Typical applications include external I/O or peripheral expansion through devices such as shift registers, display drivers, and ADCs. Multi-device communications are supported by the master/slave operation of the SPI. On the F281x and C281x, the port supports a 16-level, receive-and-transmit FIFO for reducing servicing overhead.
- SCI:** The serial communications interface is a two-wire asynchronous serial port, commonly known as UART. On the F281x and C281x, the port supports a 16-level, receive-and-transmit FIFO for reducing servicing overhead.

3.3 Register Map

The F281x and C281x devices contain three peripheral register spaces. The spaces are categorized as follows:

- Peripheral Frame 0: These are peripherals that are mapped directly to the CPU memory bus. See [Table 3-6](#).
- Peripheral Frame 1: These are peripherals that are mapped to the 32-bit peripheral bus. See [Table 3-7](#).
- Peripheral Frame 2: These are peripherals that are mapped to the 16-bit peripheral bus. See [Table 3-8](#).

Table 3-6. Peripheral Frame 0 Registers⁽¹⁾

| NAME | ADDRESS RANGE | SIZE (x16) | ACCESS TYPE ⁽²⁾ |
|--------------------------------|-----------------------|------------|-----------------------------------|
| Device Emulation Registers | 0x00 0880 – 0x00 09FF | 384 | EALLOW protected |
| Reserved | 0x00 0A00 – 0x00 0A7F | 128 | |
| FLASH Registers ⁽³⁾ | 0x00 0A80 – 0x00 0ADF | 96 | EALLOW protected CSM Protected |
| Code Security Module Registers | 0x00 0AE0 – 0x00 0AEF | 16 | EALLOW protected |
| Reserved | 0x00 0AF0 – 0x00 0B1F | 48 | |
| XINTF Registers | 0x00 0B20 – 0x00 0B3F | 32 | Not EALLOW protected |
| Reserved | 0x00 0B40 – 0x00 0BFF | 192 | |
| CPU-TIMER0/1/2 Registers | 0x00 0C00 – 0x00 0C3F | 64 | Not EALLOW protected |
| Reserved | 0x00 0C40 – 0x00 0CDF | 160 | |
| PIE Registers | 0x00 0CE0 – 0x00 0CFF | 32 | Not EALLOW protected |
| PIE Vector Table | 0x00 0D00 – 0x00 0DFF | 256 | EALLOW protected |
| Reserved | 0x00 0E00 – 0x00 0FFF | 512 | |

- (1) Registers in Frame 0 support 16-bit and 32-bit accesses.
- (2) If registers are EALLOW protected, then writes cannot be performed until the user executes the EALLOW instruction. The EDIS instruction disables writes. This prevents stray code or pointers from corrupting register contents.
- (3) The Flash Registers are also protected by the Code Security Module (CSM).

Table 3-7. Peripheral Frame 1 Registers⁽¹⁾

| NAME | ADDRESS RANGE | SIZE (x16) | ACCESS TYPE |
|------------------|-----------------------|-------------------|---|
| eCAN Registers | 0x00 6000 – 0x00 60FF | 256 (128 x 32) | Some eCAN control registers (and selected bits in other eCAN control registers) are EALLOW-protected. |
| eCAN Mailbox RAM | 0x00 6100 – 0x00 61FF | 256 (128 x 32) | Not EALLOW-protected |
| Reserved | 0x00 6200 – 0x00 6FFF | 3584 | |

- (1) The eCAN control registers only support 32-bit read/write operations. All 32-bit accesses are aligned to even address boundaries.

Table 3-8. Peripheral Frame 2 Registers⁽¹⁾

| NAME | ADDRESS RANGE | SIZE (x16) | ACCESS TYPE |
|------------------------------|-----------------------|------------|----------------------|
| Reserved | 0x00 7000 – 0x00 700F | 16 | |
| System Control Registers | 0x00 7010 – 0x00 702F | 32 | EALLOW Protected |
| Reserved | 0x00 7030 – 0x00 703F | 16 | |
| SPI-A Registers | 0x00 7040 – 0x00 704F | 16 | Not EALLOW Protected |
| SCI-A Registers | 0x00 7050 – 0x00 705F | 16 | Not EALLOW Protected |
| Reserved | 0x00 7060 – 0x00 706F | 16 | |
| External Interrupt Registers | 0x00 7070 – 0x00 707F | 16 | Not EALLOW Protected |
| Reserved | 0x00 7080 – 0x00 70BF | 64 | |
| GPIO Mux Registers | 0x00 70C0 – 0x00 70DF | 32 | EALLOW Protected |
| GPIO Data Registers | 0x00 70E0 – 0x00 70FF | 32 | Not EALLOW Protected |
| ADC Registers | 0x00 7100 – 0x00 711F | 32 | Not EALLOW Protected |
| Reserved | 0x00 7120 – 0x00 73FF | 736 | |
| EV-A Registers | 0x00 7400 – 0x00 743F | 64 | Not EALLOW Protected |
| Reserved | 0x00 7440 – 0x00 74FF | 192 | |
| EV-B Registers | 0x00 7500 – 0x00 753F | 64 | Not EALLOW Protected |
| Reserved | 0x00 7540 – 0x00 774F | 528 | |
| SCI-B Registers | 0x00 7750 – 0x00 775F | 16 | Not EALLOW Protected |
| Reserved | 0x00 7760 – 0x00 77FF | 160 | |
| McBSP Registers | 0x00 7800 – 0x00 783F | 64 | Not EALLOW Protected |
| Reserved | 0x00 7840 – 0x00 7FFF | 1984 | |

(1) Peripheral Frame 2 only allows 16-bit accesses. All 32-bit accesses are ignored (invalid data may be returned or written).

3.4 Device Emulation Registers

These registers are used to control the protection mode of the C28x CPU and to monitor some critical device signals. The registers are defined in [Table 3-9](#).

Table 3-9. Device Emulation Registers

| NAME | ADDRESS RANGE | SIZE (x16) | DESCRIPTION |
|-----------|-----------------------|------------|---|
| DEVICECNF | 0x00 0880 – 0x00 0881 | 2 | Device Configuration Register |
| PARTID | 0x00 0882 | 1 | Part ID Register 0x0001 or 0x0002 – F281x 0x0003 – C281x |
| REVID | 0x00 0883 | 1 | Revision ID Register 0x0001 – Silicon Revision A 0x0002 – Silicon Revision B 0x0003 – Silicon Revisions C, D 0x0004 – Reserved 0x0005 – Silicon Revision E 0x0006 – Silicon Revision F 0x0007 – Silicon Revision G |
| PROTSTART | 0x00 0884 | 1 | Block Protection Start Address Register |
| PROTRANGE | 0x00 0885 | 1 | Block Protection Range Address Register |
| Reserved | 0x00 0886 – 0x00 09FF | 378 | |

3.5 External Interface, XINTF (2812 Only)

This section gives a top-level view of the external interface (XINTF) that is implemented on the 2812 devices.

The external interface is a non-multiplexed asynchronous bus, similar to the C240x external interface. The external interface on the 2812 is mapped into five fixed zones shown in Figure 3-5.

Figure 3-5 shows the 2812 XINTF signals.

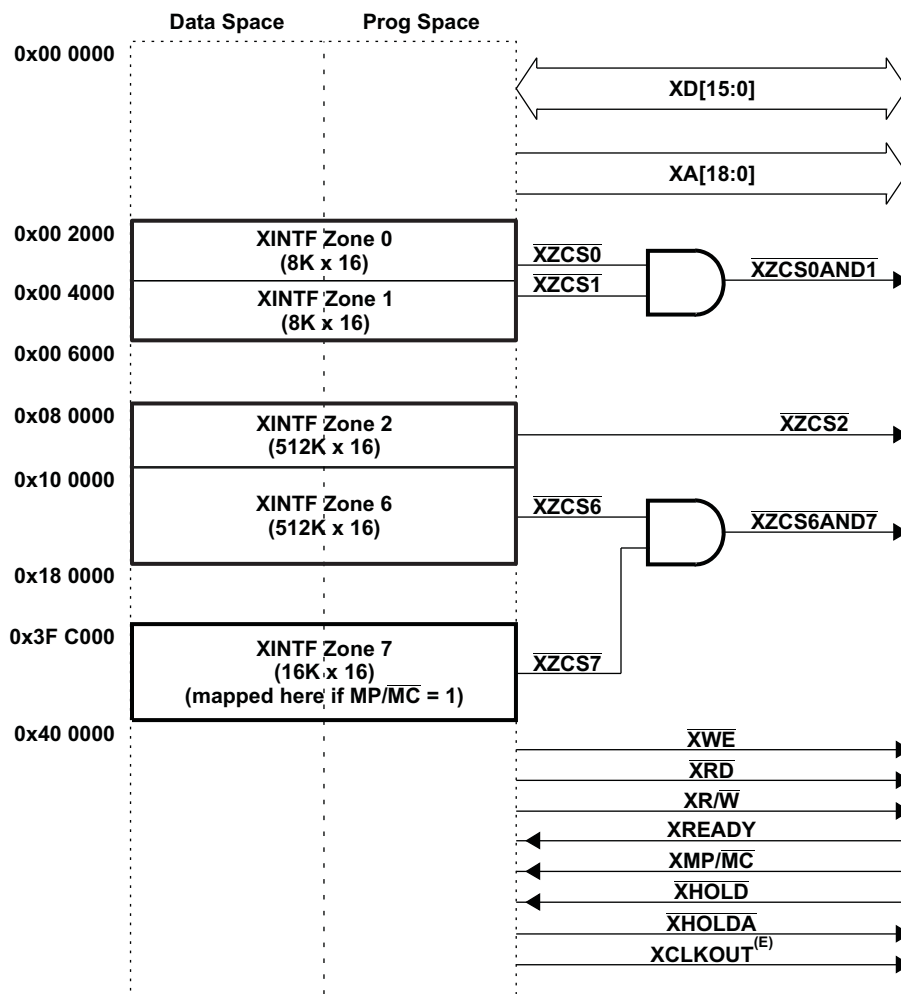

- The mapping of XINTF Zone 7 is dependent on the $\overline{\text{XMP/MC}}$ device input signal and the $\overline{\text{MP/MC}}$ mode bit (bit 8 of XINTCNF2 register). Zones 0, 1, 2, and 6 are always enabled.
- Each zone can be programmed with different wait states, setup and hold timing, and is supported by zone chip selects ($\overline{\text{XZCS0AND1}}$, $\overline{\text{XZCS2}}$, $\overline{\text{XZCS6AND7}}$), which toggle when an access to a particular zone is performed. These features enable glueless connection to many external memories and peripherals.
- The chip selects for Zone 0 and Zone 1 are ANDed internally together to form one chip select ($\overline{\text{XZCS0AND1}}$). Any external memory that is connected to $\overline{\text{XZCS0AND1}}$ is dually mapped to both Zone 0 and Zone 1.
- The chip selects for Zone 6 and Zone 7 are ANDed internally together to form one chip select ($\overline{\text{XZCS6AND7}}$). Any external memory that is connected to $\overline{\text{XZCS6AND7}}$ is dually mapped to both Zone 6 and Zone 7. This means that if Zone 7 is disabled (via the $\overline{\text{MP/MC}}$ mode), then any external memory is still accessible via Zone 6 address space.
- XCLKOUT is also pinned out on the 2810 and 2811.

Figure 3-5. External Interface Block Diagram

The operation and timing of the external interface, can be controlled by the registers listed in [Table 3-10](#).

Table 3-10. XINTF Configuration and Control Register Mappings

| NAME | ADDRESS | SIZE (x16) | DESCRIPTION |
|-----------|-----------|------------|--|
| XTIMING0 | 0x00 0B20 | 2 | XINTF Timing Register, Zone 0 can access as two 16-bit registers or one 32-bit register. |
| XTIMING1 | 0x00 0B22 | 2 | XINTF Timing Register, Zone 1 can access as two 16-bit registers or one 32-bit register. |
| XTIMING2 | 0x00 0B24 | 2 | XINTF Timing Register, Zone 2 can access as two 16-bit registers or one 32-bit register. |
| XTIMING6 | 0x00 0B2C | 2 | XINTF Timing Register, Zone 6 can access as two 16-bit registers or one 32-bit register. |
| XTIMING7 | 0x00 0B2E | 2 | XINTF Timing Register, Zone 7 can access as two 16-bit registers or one 32-bit register. |
| XINTCNF2 | 0x00 0B34 | 2 | XINTF Configuration Register can access as two 16-bit registers or one 32-bit register. |
| XBANK | 0x00 0B38 | 1 | XINTF Bank Control Register |
| XREVISION | 0x00 0B3A | 1 | XINTF Revision Register |

3.5.1 Timing Registers

XINTF signal timing can be tuned to match specific external device requirements such as setup and hold times to strobe signals for contention avoidance and maximizing bus efficiency. The XINTF timing parameters can be configured individually for each zone based on the requirements of the memory or peripheral accessed by that particular zone. This allows the programmer to maximize the efficiency of the bus on a per-zone basis. All XINTF timing values are with respect to XTIMCLK, which is equal to or one-half of the SYSCLKOUT rate, as shown in [Figure 6-30](#).

For detailed information on the XINTF timing and configuration register bit fields, see the *TMS320x281x DSP External Interface (XINTF) Reference Guide* (literature number [SPRU067](#)).

3.5.2 XREVISION Register

The XREVISION register contains a unique number to identify the particular version of XINTF used in the product. For the 2812, this register will be configured as described in [Table 3-11](#).

Table 3-11. XREVISION Register Bit Definitions

| BIT(S) | NAME | TYPE | RESET | DESCRIPTION |
|--------|----------|------|--------|--|
| 15–0 | REVISION | R | 0x0004 | Current XINTF Revision. For internal use/reference. Test purposes only. Subject to change. |

3.6 Interrupts

Figure 3-6 shows how the various interrupt sources are multiplexed within the F281x and C281x devices.

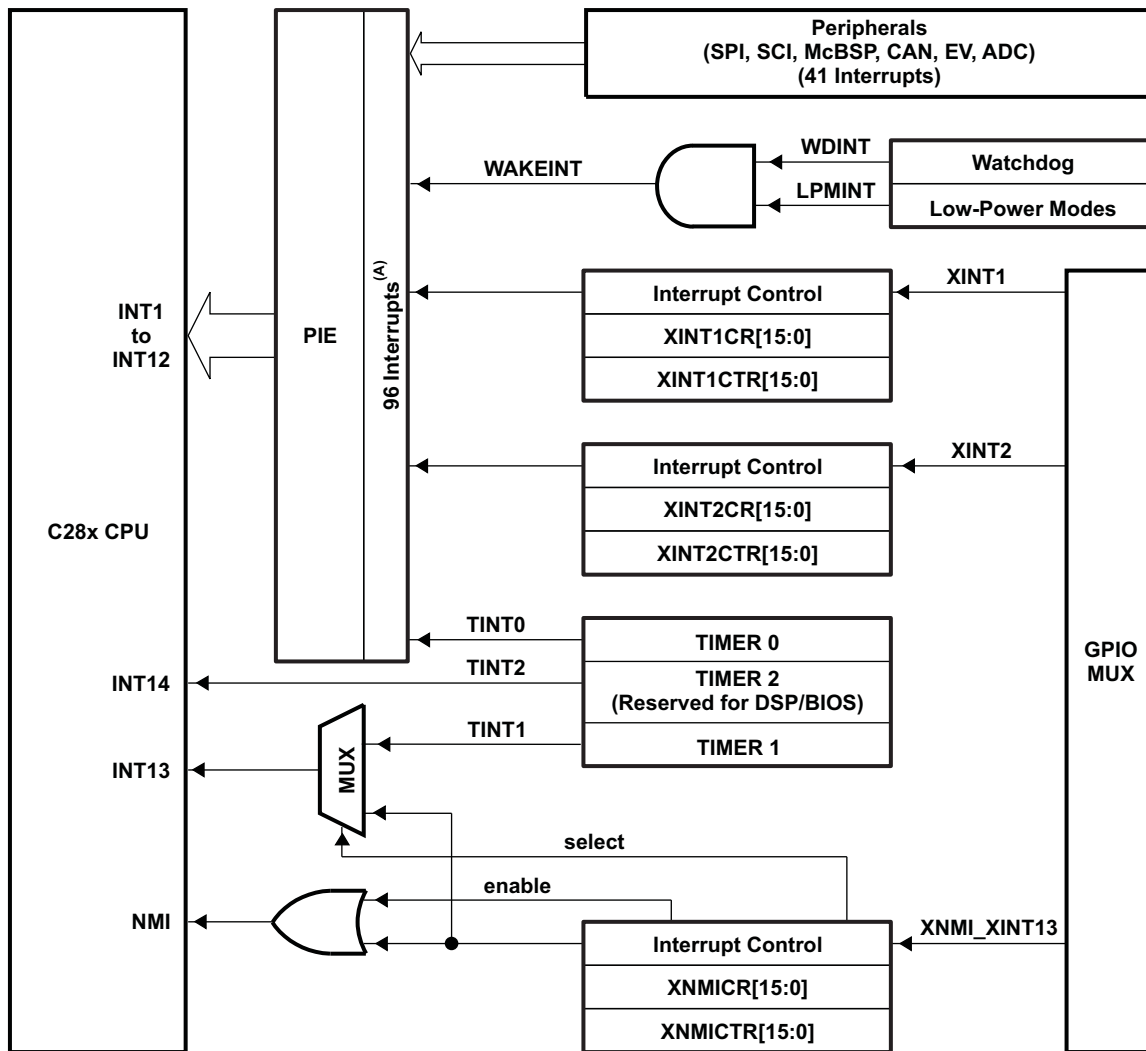

A. Out of a possible 96 interrupts, 45 are currently used by peripherals.

Figure 3-6. Interrupt Sources

Eight PIE block interrupts are grouped into one CPU interrupt. In total, 12 CPU interrupt groups, with 8 interrupts per group equals 96 possible interrupts. On the F281x and C281x, 45 of these are used by peripherals as shown in Table 3-12.

The TRAP #VectorNumber instruction transfers program control to the interrupt service routine corresponding to the vector specified. TRAP #0 attempts to transfer program control to the address pointed to by the reset vector. The PIE vector table does not, however, include a reset vector. Therefore, TRAP #0 should not be used when the PIE is enabled. Doing so will result in undefined behavior.

When the PIE is enabled, TRAP #1 through TRAP #12 will transfer program control to the interrupt service routine corresponding to the first vector within the PIE group. For example: TRAP #1 fetches the vector from INT1.1, TRAP #2 fetches the vector from INT2.1 and so forth.

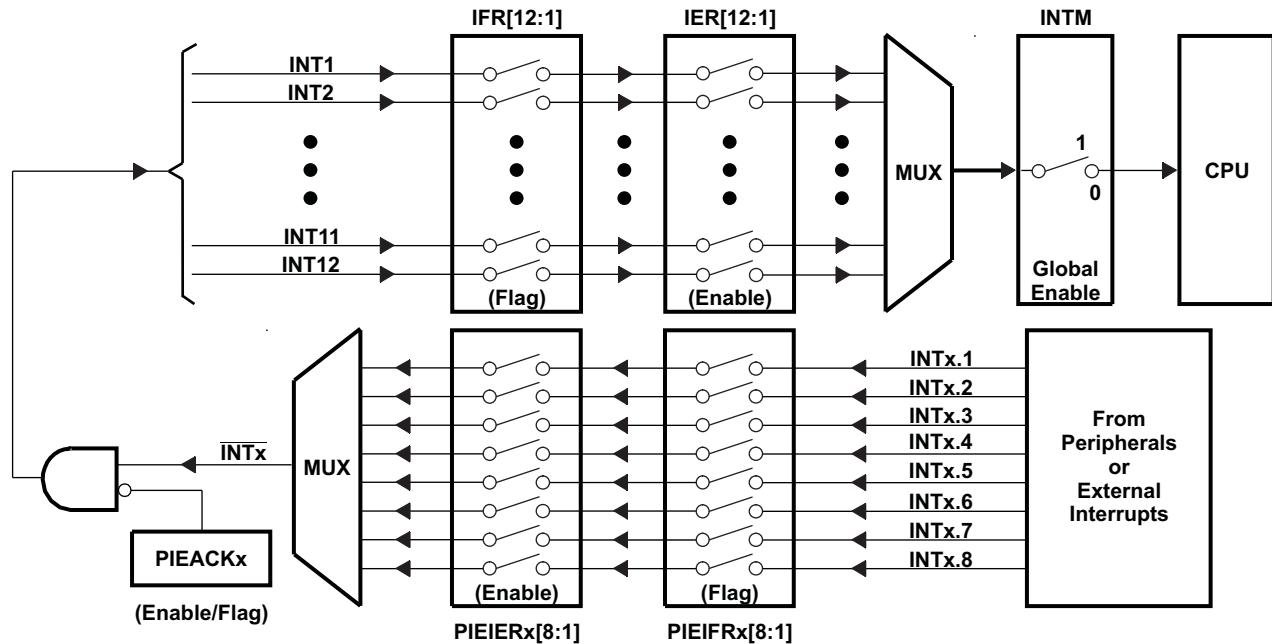

Figure 3-7. Multiplexing of Interrupts Using the PIE Block

Table 3-12. PIE Peripheral Interrupts⁽¹⁾

| CPU INTERRUPTS | PIE INTERRUPTS | | | | | | | |
|----------------|------------------|-----------------|----------------|----------------|-------------------|-------------------|-------------------|-------------------|
| | INTx.8 | INTx.7 | INTx.6 | INTx.5 | INTx.4 | INTx.3 | INTx.2 | INTx.1 |
| INT1 | WAKEINT (LPM/WD) | TINT0 (TIMER 0) | ADCINT (ADC) | XINT2 | XINT1 | Reserved | PDPINTB (EV-B) | PDPINTA (EV-A) |
| INT2 | Reserved | T1OFINT (EV-A) | T1UFINT (EV-A) | T1CINT (EV-A) | T1PINT (EV-A) | CMP3INT (EV-A) | CMP2INT (EV-A) | CMP1INT (EV-A) |
| INT3 | Reserved | CAPINT3 (EV-A) | CAPINT2 (EV-A) | CAPINT1 (EV-A) | T2OFINT (EV-A) | T2UFINT (EV-A) | T2CINT (EV-A) | T2PINT (EV-A) |
| INT4 | Reserved | T3OFINT (EV-B) | T3UFINT (EV-B) | T3CINT (EV-B) | T3PINT (EV-B) | CMP6INT (EV-B) | CMP5INT (EV-B) | CMP4INT (EV-B) |
| INT5 | Reserved | CAPINT6 (EV-B) | CAPINT5 (EV-B) | CAPINT4 (EV-B) | T4OFINT (EV-B) | T4UFINT (EV-B) | T4CINT (EV-B) | T4PINT (EV-B) |
| INT6 | Reserved | Reserved | MXINT (McBSP) | MRINT (McBSP) | Reserved | Reserved | SPITXINTA (SPI) | SPIRXINTA (SPI) |
| INT7 | Reserved | Reserved | Reserved | Reserved | Reserved | Reserved | Reserved | Reserved |
| INT8 | Reserved | Reserved | Reserved | Reserved | Reserved | Reserved | Reserved | Reserved |
| INT9 | Reserved | Reserved | ECAN1INT (CAN) | ECAN0INT (CAN) | SCITXINTB (SCI-B) | SCIRXINTB (SCI-B) | SCITXINTA (SCI-A) | SCIRXINTA (SCI-A) |
| INT10 | Reserved | Reserved | Reserved | Reserved | Reserved | Reserved | Reserved | Reserved |
| INT11 | Reserved | Reserved | Reserved | Reserved | Reserved | Reserved | Reserved | Reserved |
| INT12 | Reserved | Reserved | Reserved | Reserved | Reserved | Reserved | Reserved | Reserved |

(1) Out of the 96 possible interrupts, 45 interrupts are currently used. The remaining interrupts are reserved for future devices. These interrupts can be used as software interrupts if they are enabled at the PIEIFRx level, provided none of the interrupts within the group is being used by a peripheral. Otherwise, interrupts coming in from peripherals may be lost by accidentally clearing their flag while modifying the PIEIFR.

To summarize, there are two safe cases when the reserved interrupts could be used as software interrupts:

- No peripheral within the group is asserting interrupts.
- No peripheral interrupts are assigned to the group (example PIE group 12).

Table 3-13. PIE Configuration and Control Registers⁽¹⁾

| NAME | ADDRESS | SIZE (x16) | DESCRIPTION |
|----------|---------------------------|------------|----------------------------------|
| PIECTRL | 0x0000 0CE0 | 1 | PIE, Control Register |
| PIEACK | 0x0000 0CE1 | 1 | PIE, Acknowledge Register |
| PIEIER1 | 0x0000 0CE2 | 1 | PIE, INT1 Group Enable Register |
| PIEIFR1 | 0x0000 0CE3 | 1 | PIE, INT1 Group Flag Register |
| PIEIER2 | 0x0000 0CE4 | 1 | PIE, INT2 Group Enable Register |
| PIEIFR2 | 0x0000 0CE5 | 1 | PIE, INT2 Group Flag Register |
| PIEIER3 | 0x0000 0CE6 | 1 | PIE, INT3 Group Enable Register |
| PIEIFR3 | 0x0000 0CE7 | 1 | PIE, INT3 Group Flag Register |
| PIEIER4 | 0x0000 0CE8 | 1 | PIE, INT4 Group Enable Register |
| PIEIFR4 | 0x0000 0CE9 | 1 | PIE, INT4 Group Flag Register |
| PIEIER5 | 0x0000 0CEA | 1 | PIE, INT5 Group Enable Register |
| PIEIFR5 | 0x0000 0CEB | 1 | PIE, INT5 Group Flag Register |
| PIEIER6 | 0x0000 0CEC | 1 | PIE, INT6 Group Enable Register |
| PIEIFR6 | 0x0000 0CED | 1 | PIE, INT6 Group Flag Register |
| PIEIER7 | 0x0000 0CEE | 1 | PIE, INT7 Group Enable Register |
| PIEIFR7 | 0x0000 0CEF | 1 | PIE, INT7 Group Flag Register |
| PIEIER8 | 0x0000 0CF0 | 1 | PIE, INT8 Group Enable Register |
| PIEIFR8 | 0x0000 0CF1 | 1 | PIE, INT8 Group Flag Register |
| PIEIER9 | 0x0000 0CF2 | 1 | PIE, INT9 Group Enable Register |
| PIEIFR9 | 0x0000 0CF3 | 1 | PIE, INT9 Group Flag Register |
| PIEIER10 | 0x0000 0CF4 | 1 | PIE, INT10 Group Enable Register |
| PIEIFR10 | 0x0000 0CF5 | 1 | PIE, INT10 Group Flag Register |
| PIEIER11 | 0x0000 0CF6 | 1 | PIE, INT11 Group Enable Register |
| PIEIFR11 | 0x0000 0CF7 | 1 | PIE, INT11 Group Flag Register |
| PIEIER12 | 0x0000 0CF8 | 1 | PIE, INT12 Group Enable Register |
| PIEIFR12 | 0x0000 0CF9 | 1 | PIE, INT12 Group Flag Register |
| Reserved | 0x0000 0CFA – 0x0000 0CFF | 6 | Reserved |

(1) The PIE configuration and control registers are not protected by EALLOW mode. The PIE vector table is protected.

3.6.1 External Interrupts

Table 3-14. External Interrupts Registers

| NAME | ADDRESS | SIZE (x16) | DESCRIPTION |
|----------|-----------------------|------------|------------------------|
| XINT1CR | 0x00 7070 | 1 | XINT1 control register |
| XINT2CR | 0x00 7071 | 1 | XINT2 control register |
| Reserved | 0x00 7072 – 0x00 7076 | 5 | |
| XNMICR | 0x00 7077 | 1 | XNMI control register |
| XINT1CTR | 0x00 7078 | 1 | XINT1 counter register |
| XINT2CTR | 0x00 7079 | 1 | XINT2 counter register |
| Reserved | 0x00 707A – 0x00 707E | 5 | |
| XNMICTR | 0x00 707F | 1 | XNMI counter register |

Each external interrupt can be enabled/disabled or qualified using positive or negative going edge. For more information, see the *TMS320x281x DSP System Control and Interrupts Reference Guide* (literature number [SPRU078](#)).

3.7 System Control

This section describes the F281x and C281x oscillator, PLL and clocking mechanisms, the watchdog function and the low-power modes. Figure 3-8 shows the various clock and reset domains in the F281x and C281x devices that will be discussed.

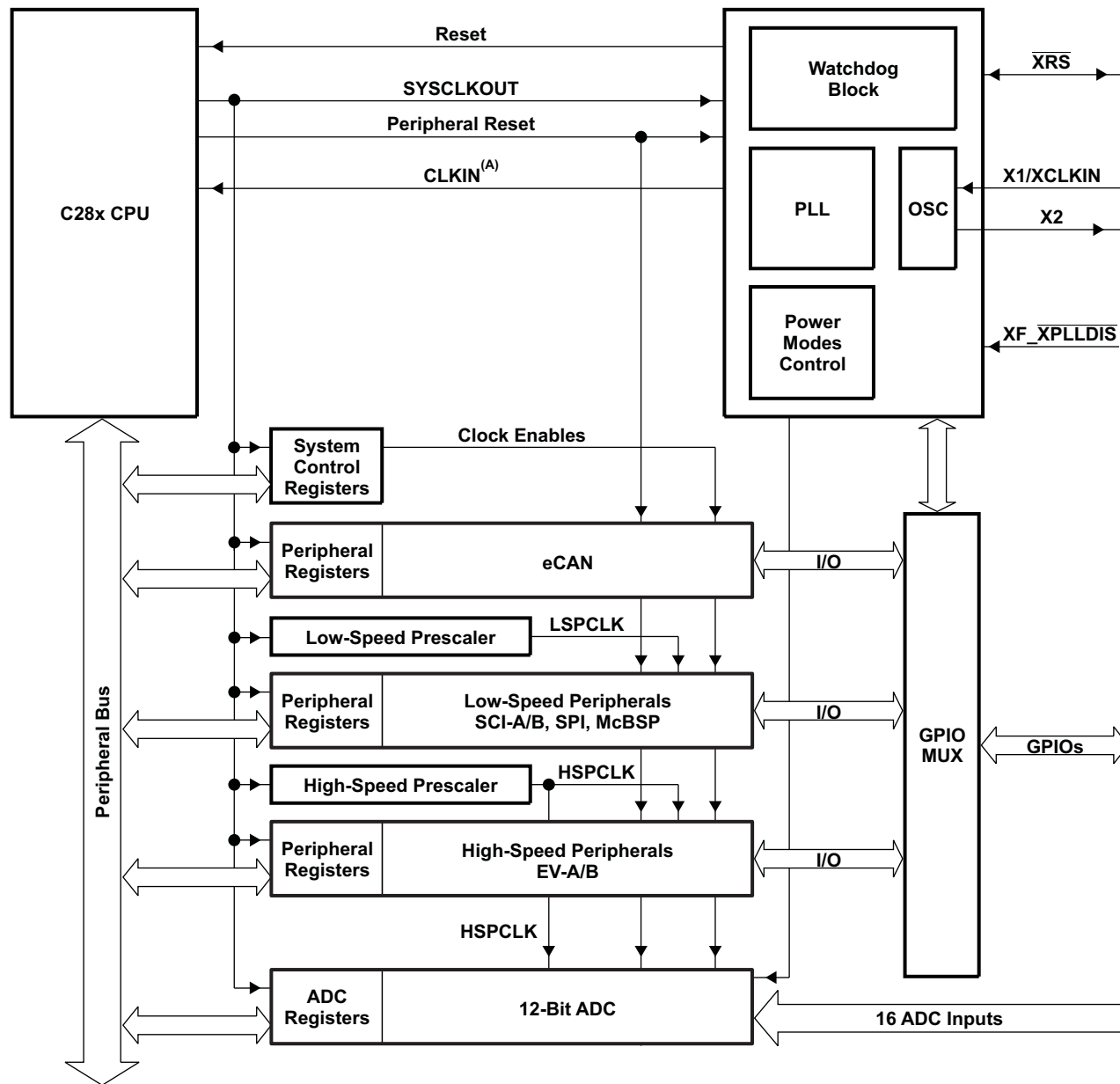

A. CLKIN is the clock input to the CPU. SYSCLKOUT is the output clock of the CPU. They are of the same frequency.

Figure 3-8. Clock and Reset Domains

The PLL, clocking, watchdog and low-power modes, are controlled by the registers listed in [Table 3-15](#).

Table 3-15. PLL, Clocking, Watchdog, and Low-Power Mode Registers⁽¹⁾

| NAME | ADDRESS | SIZE (x16) | DESCRIPTION |
|----------|-----------------------|------------|---|
| Reserved | 0x00 7010 – 0x00 7017 | 8 | |
| Reserved | 0x00 7018 | 1 | |
| Reserved | 0x00 7019 | 1 | |
| HISPCP | 0x00 701A | 1 | High-Speed Peripheral Clock Prescaler Register for HSPCLK clock |
| LOSPCP | 0x00 701B | 1 | Low-Speed Peripheral Clock Prescaler Register for LSPCLK clock |
| PCLKCR | 0x00 701C | 1 | Peripheral Clock Control Register |
| Reserved | 0x00 701D | 1 | |
| LPMCR0 | 0x00 701E | 1 | Low-Power Mode Control Register 0 |
| LPMCR1 | 0x00 701F | 1 | Low-Power Mode Control Register 1 |
| Reserved | 0x00 7020 | 1 | |
| PLLCR | 0x00 7021 | 1 | PLL Control Register ⁽²⁾ |
| SCSR | 0x00 7022 | 1 | System Control and Status Register |
| WDCNTR | 0x00 7023 | 1 | Watchdog Counter Register |
| Reserved | 0x00 7024 | 1 | |
| WDKEY | 0x00 7025 | 1 | Watchdog Reset Key Register |
| Reserved | 0x00 7026 – 0x00 7028 | 3 | |
| WDCR | 0x00 7029 | 1 | Watchdog Control Register |
| Reserved | 0x00 702A – 0x00 702F | 6 | |

(1) All of the above registers can only be accessed by executing the `EALLOW` instruction.

(2) The PLL control register (PLLCR) is reset to a known state by the $\overline{\text{XRS}}$ signal only. Emulation reset (through Code Composer Studio) will not reset PLLCR.

3.8 OSC and PLL Block

Figure 3-9 shows the OSC and PLL block on the F281x and C281x.

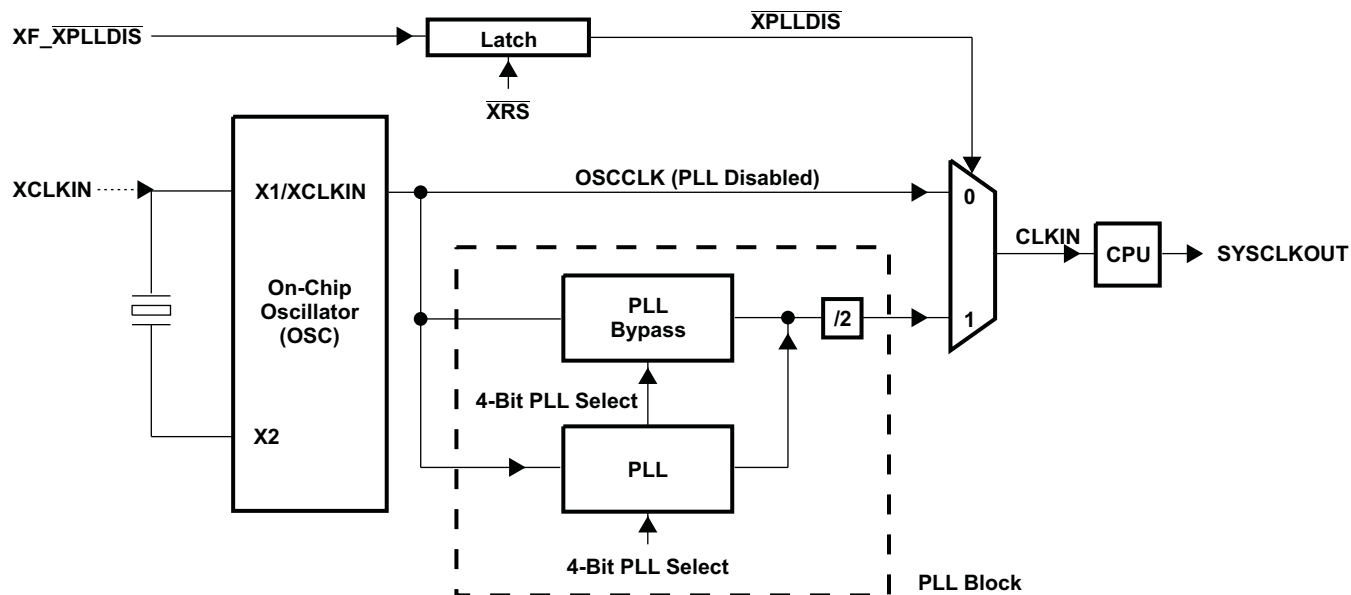

Figure 3-9. OSC and PLL Block

The on-chip oscillator circuit enables a crystal to be attached to the F281x and C281x devices using the X1/XCLKIN and X2 pins. If a crystal is not used, then an external oscillator can be directly connected to the X1/XCLKIN pin and the X2 pin is left unconnected. The logic-high level in this case should not exceed V_{DD} . The PLLCR bits [3:0] set the clocking ratio.

Table 3-16. PLLCR Register Bit Definitions

| BIT(S) | NAME | TYPE | $\overline{\text{XRS}}$ RESET ⁽¹⁾ | DESCRIPTION | | | | | | | | | | | | | | | | | | | | | | | | | | | | | | | | | | | | | | | | | | | | | | | | | | | |
|-----------|--------------|--------------|---|---|-----------|---|-----------|------|--------------|----------|------|---|----------|------|---|--------|------|---|--------------|------|---|------------|------|---|--------------|------|---|------------|------|---|--------------|------|---|------------|------|---|--------------|------|----|------------|------|----|----------|------|----|----------|------|----|----------|------|----|----------|------|----|----------|
| 15:4 | Reserved | R = 0 | 0:0 | | | | | | | | | | | | | | | | | | | | | | | | | | | | | | | | | | | | | | | | | | | | | | | | | | | | |
| 3:0 | DIV | R/W | 0,0,0,0 | <p>SYSCLKOUT = (XCLKIN * n)/2, where n is the PLL multiplication factor.</p> <table border="1"> <thead> <tr> <th>Bit Value</th> <th>n</th> <th>SYSCLKOUT</th> </tr> </thead> <tbody> <tr> <td>0000</td> <td>PLL Bypassed</td> <td>XCLKIN/2</td> </tr> <tr> <td>0001</td> <td>1</td> <td>XCLKIN/2</td> </tr> <tr> <td>0010</td> <td>2</td> <td>XCLKIN</td> </tr> <tr> <td>0011</td> <td>3</td> <td>XCLKIN * 1.5</td> </tr> <tr> <td>0100</td> <td>4</td> <td>XCLKIN * 2</td> </tr> <tr> <td>0101</td> <td>5</td> <td>XCLKIN * 2.5</td> </tr> <tr> <td>0110</td> <td>6</td> <td>XCLKIN * 3</td> </tr> <tr> <td>0111</td> <td>7</td> <td>XCLKIN * 3.5</td> </tr> <tr> <td>1000</td> <td>8</td> <td>XCLKIN * 4</td> </tr> <tr> <td>1001</td> <td>9</td> <td>XCLKIN * 4.5</td> </tr> <tr> <td>1010</td> <td>10</td> <td>XCLKIN * 5</td> </tr> <tr> <td>1011</td> <td>11</td> <td>Reserved</td> </tr> <tr> <td>1100</td> <td>12</td> <td>Reserved</td> </tr> <tr> <td>1101</td> <td>13</td> <td>Reserved</td> </tr> <tr> <td>1110</td> <td>14</td> <td>Reserved</td> </tr> <tr> <td>1111</td> <td>15</td> <td>Reserved</td> </tr> </tbody> </table> | Bit Value | n | SYSCLKOUT | 0000 | PLL Bypassed | XCLKIN/2 | 0001 | 1 | XCLKIN/2 | 0010 | 2 | XCLKIN | 0011 | 3 | XCLKIN * 1.5 | 0100 | 4 | XCLKIN * 2 | 0101 | 5 | XCLKIN * 2.5 | 0110 | 6 | XCLKIN * 3 | 0111 | 7 | XCLKIN * 3.5 | 1000 | 8 | XCLKIN * 4 | 1001 | 9 | XCLKIN * 4.5 | 1010 | 10 | XCLKIN * 5 | 1011 | 11 | Reserved | 1100 | 12 | Reserved | 1101 | 13 | Reserved | 1110 | 14 | Reserved | 1111 | 15 | Reserved |
| Bit Value | n | SYSCLKOUT | | | | | | | | | | | | | | | | | | | | | | | | | | | | | | | | | | | | | | | | | | | | | | | | | | | | | |
| 0000 | PLL Bypassed | XCLKIN/2 | | | | | | | | | | | | | | | | | | | | | | | | | | | | | | | | | | | | | | | | | | | | | | | | | | | | | |
| 0001 | 1 | XCLKIN/2 | | | | | | | | | | | | | | | | | | | | | | | | | | | | | | | | | | | | | | | | | | | | | | | | | | | | | |
| 0010 | 2 | XCLKIN | | | | | | | | | | | | | | | | | | | | | | | | | | | | | | | | | | | | | | | | | | | | | | | | | | | | | |
| 0011 | 3 | XCLKIN * 1.5 | | | | | | | | | | | | | | | | | | | | | | | | | | | | | | | | | | | | | | | | | | | | | | | | | | | | | |
| 0100 | 4 | XCLKIN * 2 | | | | | | | | | | | | | | | | | | | | | | | | | | | | | | | | | | | | | | | | | | | | | | | | | | | | | |
| 0101 | 5 | XCLKIN * 2.5 | | | | | | | | | | | | | | | | | | | | | | | | | | | | | | | | | | | | | | | | | | | | | | | | | | | | | |
| 0110 | 6 | XCLKIN * 3 | | | | | | | | | | | | | | | | | | | | | | | | | | | | | | | | | | | | | | | | | | | | | | | | | | | | | |
| 0111 | 7 | XCLKIN * 3.5 | | | | | | | | | | | | | | | | | | | | | | | | | | | | | | | | | | | | | | | | | | | | | | | | | | | | | |
| 1000 | 8 | XCLKIN * 4 | | | | | | | | | | | | | | | | | | | | | | | | | | | | | | | | | | | | | | | | | | | | | | | | | | | | | |
| 1001 | 9 | XCLKIN * 4.5 | | | | | | | | | | | | | | | | | | | | | | | | | | | | | | | | | | | | | | | | | | | | | | | | | | | | | |
| 1010 | 10 | XCLKIN * 5 | | | | | | | | | | | | | | | | | | | | | | | | | | | | | | | | | | | | | | | | | | | | | | | | | | | | | |
| 1011 | 11 | Reserved | | | | | | | | | | | | | | | | | | | | | | | | | | | | | | | | | | | | | | | | | | | | | | | | | | | | | |
| 1100 | 12 | Reserved | | | | | | | | | | | | | | | | | | | | | | | | | | | | | | | | | | | | | | | | | | | | | | | | | | | | | |
| 1101 | 13 | Reserved | | | | | | | | | | | | | | | | | | | | | | | | | | | | | | | | | | | | | | | | | | | | | | | | | | | | | |
| 1110 | 14 | Reserved | | | | | | | | | | | | | | | | | | | | | | | | | | | | | | | | | | | | | | | | | | | | | | | | | | | | | |
| 1111 | 15 | Reserved | | | | | | | | | | | | | | | | | | | | | | | | | | | | | | | | | | | | | | | | | | | | | | | | | | | | | |

(1) The PLLCR register is reset to a known state by the $\overline{\text{XRS}}$ reset line. **If a reset is issued by the debugger, the PLL clocking ratio is not changed.**

3.8.1 Loss of Input Clock

In PLL enabled mode, if the input clock XCLKIN or the oscillator clock is removed or absent, the PLL will still issue a “limp-mode” clock. The limp-mode clock will continue to clock the CPU and peripherals at a typical frequency of 1–4 MHz. The PLLCR register should have been written to with a non-zero value for this feature to work.

Normally, when the input clocks are present, the watchdog counter will decrement to initiate a watchdog reset or WDINT interrupt. However, when the external input clock fails, the watchdog counter will stop decrementing (that is, the watchdog counter does not change with the limp-mode clock). This condition could be used by the application firmware to detect the input clock failure and initiate necessary shut-down procedure for the system.

NOTE

Applications in which the correct CPU operating frequency is absolutely critical must implement a mechanism by which the DSP will be held in reset, should the input clocks ever fail. For example, an R-C circuit may be used to trigger the $\overline{\text{XRS}}$ pin of the DSP, should the capacitor ever get fully charged. An I/O pin may be used to discharge the capacitor on a periodic basis to prevent it from getting fully charged. Such a circuit would also help in detecting failure of the V_{DD3VFL} rail.

3.9 PLL-Based Clock Module

The F281x and C281x have an on-chip, PLL-based clock module. This module provides all the necessary clocking signals for the device, as well as control for low-power mode entry. The PLL has a 4-bit ratio control to select different CPU clock rates. The watchdog module should be disabled before writing to the PLLCR register. It can be re-enabled (if need be) after the PLL module has stabilized, which takes 131072 XCLKIN cycles.

The PLL-based clock module provides two modes of operation:

- **Crystal operation:** This mode allows the use of an external crystal/resonator to provide the time base to the device.
- **External clock source operation:** This mode allows the internal oscillator to be bypassed. The device clocks are generated from an external clock source input on the X1/XCLKIN pin.

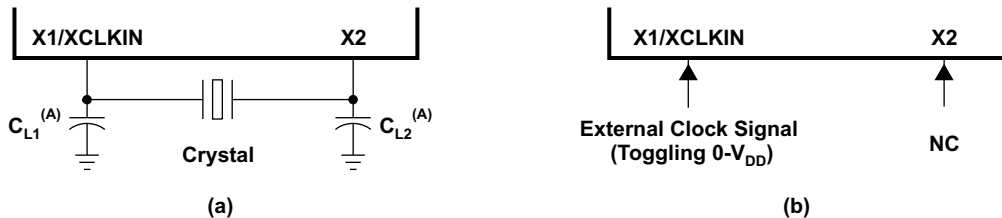

- A. TI recommends that customers have the resonator/crystal vendor characterize the operation of their device with the DSP chip. The resonator/crystal vendor has the equipment and expertise to tune the tank circuit. The vendor can also advise the customer regarding the proper tank component values that will ensure start-up and stability over the entire operating range.

Figure 3-10. Recommended Crystal/Clock Connection

Table 3-17. Possible PLL Configuration Modes

| PLL MODE | REMARKS | SYSCLOCKOUT |
|--------------|--|---------------------------|
| PLL Disabled | Invoked by tying $\overline{\text{XPLLDIS}}$ pin low upon reset. PLL block is completely disabled. Clock input to the CPU (CLKIN) is directly derived from the clock signal present at the X1/XCLKIN pin. | XCLKIN |
| PLL Bypassed | Default PLL configuration upon power-up, if PLL is not disabled. The PLL itself is bypassed. However, the /2 module in the PLL block divides the clock input at the X1/XCLKIN pin by two before feeding it to the CPU. | XCLKIN/2 |
| PLL Enabled | Achieved by writing a non-zero value "n" into PLLCR register. The /2 module in the PLL block now divides the output of the PLL by two before feeding it to the CPU. | $(\text{XCLKIN} * n) / 2$ |

3.10 External Reference Oscillator Clock Option

The typical specifications for the external quartz crystal for a frequency of 30 MHz are listed below:

- Fundamental mode, parallel resonant
- C_L (load capacitance) = 12 pF
- $C_{L1} = C_{L2} = 24$ pF
- $C_{shunt} = 6$ pF
- ESR range = 25 to 40 Ω

3.11 Watchdog Block

The watchdog block on the F281x and C281x is identical to the one used on the 240x devices. The watchdog module generates an output pulse, 512 oscillator clocks wide (OSCCLK), whenever the 8-bit watchdog up counter has reached its maximum value. To prevent this, the user disables the counter or the software must periodically write a 0x55 + 0xAA sequence into the watchdog key register which will reset the watchdog counter. Figure 3-11 shows the various functional blocks within the watchdog module.

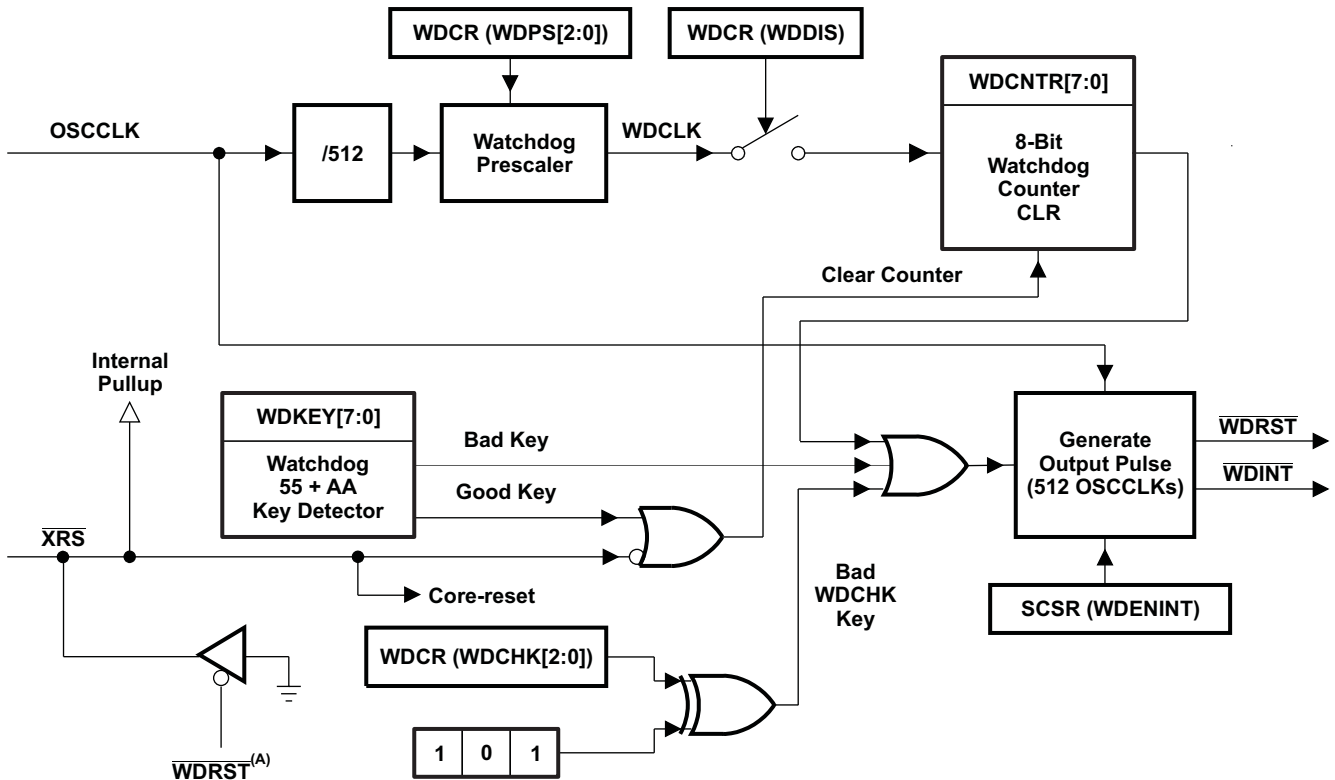

A. The \overline{WDRST} signal is driven low for 512 OSCCLK cycles.

Figure 3-11. Watchdog Module

The \overline{WDINT} signal enables the watchdog to be used as a wakeup from IDLE/STANDBY mode timer.

In STANDBY mode, all peripherals are turned off on the device. The only peripheral that remains functional is the watchdog. The WATCHDOG module will run off the PLL clock or the oscillator clock. The \overline{WDINT} signal is fed to the LPM block so that it can wake the device from STANDBY (if enabled). See Section 3.12, Low-Power Modes Block, for more details.

In IDLE mode, the \overline{WDINT} signal can generate an interrupt to the CPU, via the PIE, to take the CPU out of IDLE mode.

In HALT mode, this feature cannot be used because the oscillator (and PLL) are turned off and hence, so is the WATCHDOG.

3.12 Low-Power Modes Block

The low-power modes on the F281x and C281x are similar to the 240x devices. [Table 3-18](#) summarizes the various modes.

Table 3-18. F281x and C281x Low-Power Modes

| MODE | LPM[1:0] | OSCCLK | CLKIN | SYSCCLKOUT | EXIT ⁽¹⁾ |
|---------|----------|--|-------|-------------------|---|
| Normal | X,X | on | on | on | – |
| IDLE | 0,0 | on | on | on ⁽²⁾ | \overline{XRS} , WDINT, Any Enabled Interrupt, XNMI, Debugger ⁽³⁾ |
| STANDBY | 0,1 | on (watchdog still running) | off | off | \overline{XRS} , WDINT, XINT1, XNMI, $\overline{T1/2/3/4CTRIP}$, $\overline{C1/2/3/4/5/6TRIP}$, SCIRXDA, SCIRXDB, CANRX, Debugger ⁽³⁾ |
| HALT | 1,X | off (oscillator and PLL turned off, watchdog not functional) | off | off | \overline{XRS} , XNMI, Debugger ⁽³⁾ |

- (1) The Exit column lists which signals or under what conditions the low-power mode will be exited. A low signal, on any of the signals, will exit the low-power condition. This signal must be kept low long enough for an interrupt to be recognized by the device. Otherwise, the IDLE mode will not be exited and the device will go back into the indicated low-power mode.
- (2) The IDLE mode on the C28x behaves differently than on the 24x/240x. On the C28x, the clock output from the core (SYSCCLKOUT) is still functional; while on the 24x/240x, the clock is turned off.
- (3) On the C28x, the JTAG port can still function even if the core clock (CLKIN) is turned off.

The various low-power modes operate as follows:

- IDLE Mode** This mode is exited by any enabled interrupt or an XNMI that is recognized by the processor. The LPM block performs no tasks during this mode as long as the LPMCR0(LPM) bits are set to 0,0.
- STANDBY Mode** All other signals (including XNMI) will wake the device from STANDBY mode if selected by the LPMCR1 register. The user will need to select which signal(s) will wake the device. The selected signal(s) are also qualified by the OSCCLK before waking the device. The number of OSCCLKs is specified in the LPMCR0 register.
- HALT Mode** Only the \overline{XRS} and XNMI external signals can wake the device from HALT mode. The XNMI input to the core has an enable/disable bit. Hence, it is safe to use the XNMI signal for this function.

NOTE

The low-power modes do not affect the state of the output pins (PWM pins included). They will be in whatever state the code left them when the IDLE instruction was executed.

4 Peripherals

The integrated peripherals of the F281x and C281x are described in the following subsections:

- Three 32-bit CPU-Timers
- Two event-manager modules (EVA, EVB)
- Enhanced analog-to-digital converter (ADC) module
- Enhanced controller area network (eCAN) module
- Multichannel buffered serial port (McBSP) module
- Serial communications interface modules (SCI-A, SCI-B)
- Serial peripheral interface (SPI) module
- Digital I/O and shared pin functions

4.1 32-Bit CPU-Timers 0/1/2

There are three 32-bit CPU-timers on the F281x and C281x devices (CPU-TIMER0/1/2).

Timer 2 is reserved for DSP/BIOS. CPU-Timer 0 and CPU-Timer 1 can be used in user applications. These timers are different from the general-purpose (GP) timers that are present in the Event Manager modules (EVA, EVB).

NOTE

If the application is not using DSP/BIOS, then CPU-Timer 2 can be used in the application.

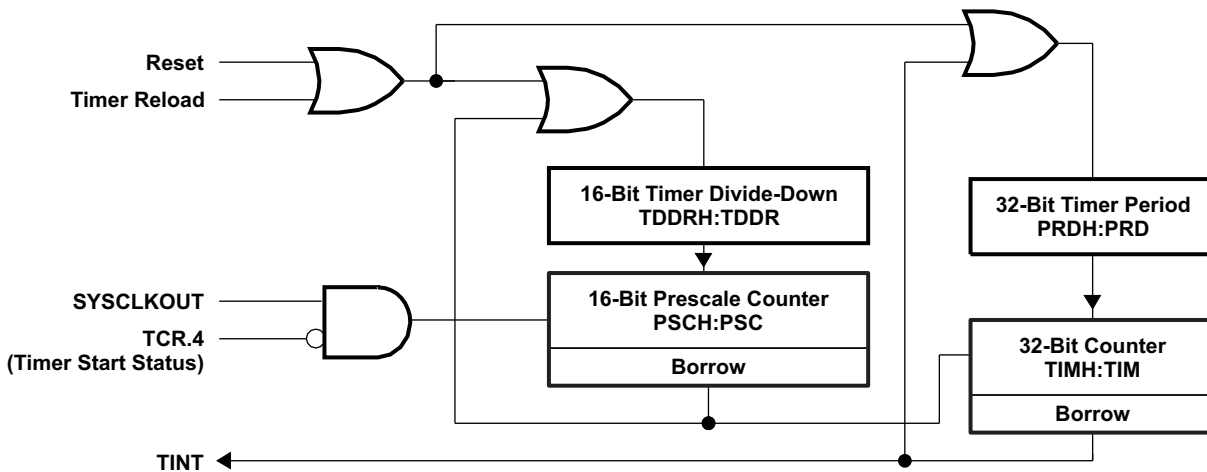
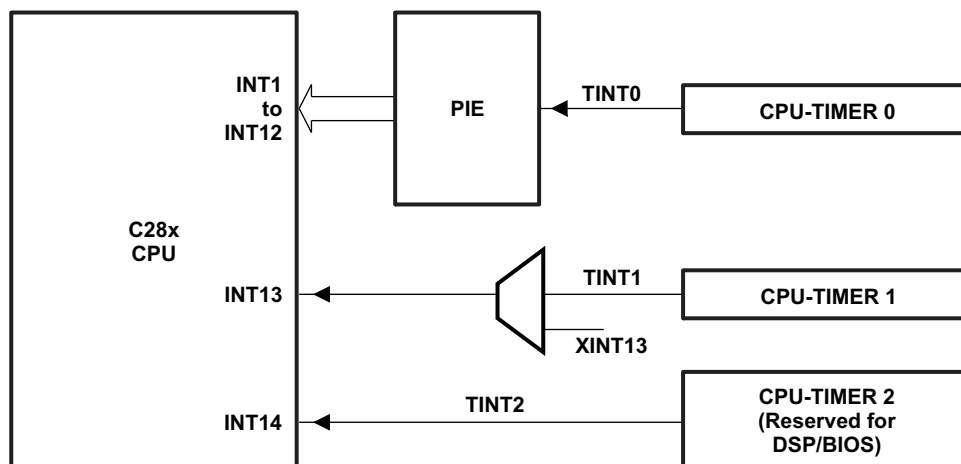

Figure 4-1. CPU-Timers

In the F281x and C281x devices, the timer interrupt signals (TINT0, TINT1, TINT2) are connected as shown in Figure 4-2.



- A. The timer registers are connected to the memory bus of the C28x processor.
- B. The timing of the timers is synchronized to SYSCLKOUT of the processor clock.

Figure 4-2. CPU-Timer Interrupts Signals and Output Signal

The general operation of the timer is as follows: The 32-bit counter register “TIMH:TIM” is loaded with the value in the period register “PRDH:PRD”. The counter register decrements at the SYSCLKOUT rate of the C28x. When the counter reaches 0, a timer interrupt output signal generates an interrupt pulse. The registers listed in Table 4-1 are used to configure the timers. For more information, see the *TMS320x281x DSP System Control and Interrupts Reference Guide* (literature number [SPRU078](#)).

Table 4-1. CPU-Timers 0, 1, 2 Configuration and Control Registers

| NAME | ADDRESS | SIZE (x16) | DESCRIPTION |
|------------|-----------------------|------------|-------------------------------------|
| TIMER0TIM | 0x00 0C00 | 1 | CPU-Timer 0, Counter Register |
| TIMER0TIMH | 0x00 0C01 | 1 | CPU-Timer 0, Counter Register High |
| TIMER0PRD | 0x00 0C02 | 1 | CPU-Timer 0, Period Register |
| TIMER0PRDH | 0x00 0C03 | 1 | CPU-Timer 0, Period Register High |
| TIMER0TCR | 0x00 0C04 | 1 | CPU-Timer 0, Control Register |
| Reserved | 0x00 0C05 | 1 | |
| TIMER0TPR | 0x00 0C06 | 1 | CPU-Timer 0, Prescale Register |
| TIMER0TPRH | 0x00 0C07 | 1 | CPU-Timer 0, Prescale Register High |
| TIMER1TIM | 0x00 0C08 | 1 | CPU-Timer 1, Counter Register |
| TIMER1TIMH | 0x00 0C09 | 1 | CPU-Timer 1, Counter Register High |
| TIMER1PRD | 0x00 0C0A | 1 | CPU-Timer 1, Period Register |
| TIMER1PRDH | 0x00 0C0B | 1 | CPU-Timer 1, Period Register High |
| TIMER1TCR | 0x00 0C0C | 1 | CPU-Timer 1, Control Register |
| Reserved | 0x00 0C0D | 1 | |
| TIMER1TPR | 0x00 0C0E | 1 | CPU-Timer 1, Prescale Register |
| TIMER1TPRH | 0x00 0C0F | 1 | CPU-Timer 1, Prescale Register High |
| TIMER2TIM | 0x00 0C10 | 1 | CPU-Timer 2, Counter Register |
| TIMER2TIMH | 0x00 0C11 | 1 | CPU-Timer 2, Counter Register High |
| TIMER2PRD | 0x00 0C12 | 1 | CPU-Timer 2, Period Register |
| TIMER2PRDH | 0x00 0C13 | 1 | CPU-Timer 2, Period Register High |
| TIMER2TCR | 0x00 0C14 | 1 | CPU-Timer 2, Control Register |
| Reserved | 0x00 0C15 | 1 | |
| TIMER2TPR | 0x00 0C16 | 1 | CPU-Timer 2, Prescale Register |
| TIMER2TPRH | 0x00 0C17 | 1 | CPU-Timer 2, Prescale Register High |
| Reserved | 0x00 0C18 – 0x00 0C3F | 40 | |

4.2 Event Manager Modules (EVA, EVB)

The event-manager modules include general-purpose (GP) timers, full-compare/PWM units, capture units, and quadrature-encoder pulse (QEP) circuits. EVA and EVB timers, compare units, and capture units function identically. However, timer/unit names differ for EVA and EVB. [Table 4-2](#) shows the module and signal names used. [Table 4-2](#) shows the features and functionality available for the event-manager modules and highlights EVA nomenclature.

Event managers A and B have identical peripheral register sets with EVA starting at 7400h and EVB starting at 7500h. The paragraphs in this section describe the function of GP timers, compare units, capture units, and QEPs using EVA nomenclature. These paragraphs are applicable to EVB with regard to function—however, module/signal names would differ. [Table 4-3](#) lists the EVA registers. For more information, see the *TMS320x281x DSP Event Manager (EV) Reference Guide* (literature number [SPRU065](#)).

Table 4-2. Module and Signal Names for EVA and EVB

| EVENT MANAGER MODULES | EVA | | EVB | |
|-----------------------|-------------------------------------|--|-------------------------------------|--|
| | MODULE | SIGNAL | MODULE | SIGNAL |
| GP Timers | GP Timer 1 GP Timer 2 | T1PWM/T1CMP T2PWM/T2CMP | GP Timer 3 GP Timer 4 | T3PWM/T3CMP T4PWM/T4CMP |
| Compare Units | Compare 1 Compare 2 Compare 3 | PWM1/2 PWM3/4 PWM5/6 | Compare 4 Compare 5 Compare 6 | PWM7/8 PWM9/10 PWM11/12 |
| Capture Units | Capture 1 Capture 2 Capture 3 | CAP1 CAP2 CAP3 | Capture 4 Capture 5 Capture 6 | CAP4 CAP5 CAP6 |
| QEP Channels | QEP1 QEP2 QEP11 | QEP1 QEP2 | QEP3 QEP4 QEP12 | QEP3 QEP4 |
| External Clock Inputs | Direction External Clock | TDIRA TCLKINA | Direction External Clock | TDIRB TCLKINB |
| External Trip Inputs | Compare | C1TRIP C2TRIP C3TRIP | Compare | C4TRIP C5TRIP C6TRIP |
| External Trip Inputs | | T1CTRIP_PDPINTA ⁽¹⁾ T2CTRIP/EVASOC | | T3CTRIP_PDPINTB ⁽¹⁾ T4CTRIP/EVBSOC |

(1) In the 24x/240x-compatible mode, the T1CTRIP_PDPINTA pin functions as PDPINTA and the T3CTRIP_PDPINTB pin functions as PDPINTB.

Table 4-3. EVA Registers⁽¹⁾

| NAME | ADDRESS | SIZE (x16) | DESCRIPTION |
|------------------------|-----------|------------|---|
| GPTCONA | 0x00 7400 | 1 | GP Timer Control Register A |
| T1CNT | 0x00 7401 | 1 | GP Timer 1 Counter Register |
| T1CMPR | 0x00 7402 | 1 | GP Timer 1 Compare Register |
| T1PR | 0x00 7403 | 1 | GP Timer 1 Period Register |
| T1CON | 0x00 7404 | 1 | GP Timer 1 Control Register |
| T2CNT | 0x00 7405 | 1 | GP Timer 2 Counter Register |
| T2CMPR | 0x00 7406 | 1 | GP Timer 2 Compare Register |
| T2PR | 0x00 7407 | 1 | GP Timer 2 Period Register |
| T2CON | 0x00 7408 | 1 | GP Timer 2 Control Register |
| EXTCONA ⁽²⁾ | 0x00 7409 | 1 | GP Extension Control Register A |
| COMCONA | 0x00 7411 | 1 | Compare Control Register A |
| ACTRA | 0x00 7413 | 1 | Compare Action Control Register A |
| DBTCONA | 0x00 7415 | 1 | Dead-Band Timer Control Register A |
| CMPR1 | 0x00 7417 | 1 | Compare Register 1 |
| CMPR2 | 0x00 7418 | 1 | Compare Register 2 |
| CMPR3 | 0x00 7419 | 1 | Compare Register 3 |
| CAPCONA | 0x00 7420 | 1 | Capture Control Register A |
| CAPFIFOA | 0x00 7422 | 1 | Capture FIFO Status Register A |
| CAP1FIFO | 0x00 7423 | 1 | Two-Level-Deep Capture FIFO Stack 1 |
| CAP2FIFO | 0x00 7424 | 1 | Two-Level-Deep Capture FIFO Stack 2 |
| CAP3FIFO | 0x00 7425 | 1 | Two-Level-Deep Capture FIFO Stack 3 |
| CAP1FBOT | 0x00 7427 | 1 | Bottom Register of Capture FIFO Stack 1 |
| CAP2FBOT | 0x00 7428 | 1 | Bottom Register of Capture FIFO Stack 2 |
| CAP3FBOT | 0x00 7429 | 1 | Bottom Register of Capture FIFO Stack 3 |
| EVAIMRA | 0x00 742C | 1 | Interrupt Mask Register A |
| EVAIMRB | 0x00 742D | 1 | Interrupt Mask Register B |
| EVAIMRC | 0x00 742E | 1 | Interrupt Mask Register C |
| EVAIFRA | 0x00 742F | 1 | Interrupt Flag Register A |
| EVAIFRB | 0x00 7430 | 1 | Interrupt Flag Register B |
| EVAIFRC | 0x00 7431 | 1 | Interrupt Flag Register C |

(1) The EV-B register set is identical except the address range is from 0x00 7500 to 0x00 753F. The above registers are mapped to Zone 2. This space allows only 16-bit accesses. 32-bit accesses produce undefined results.

(2) New register compared to 24x/240x

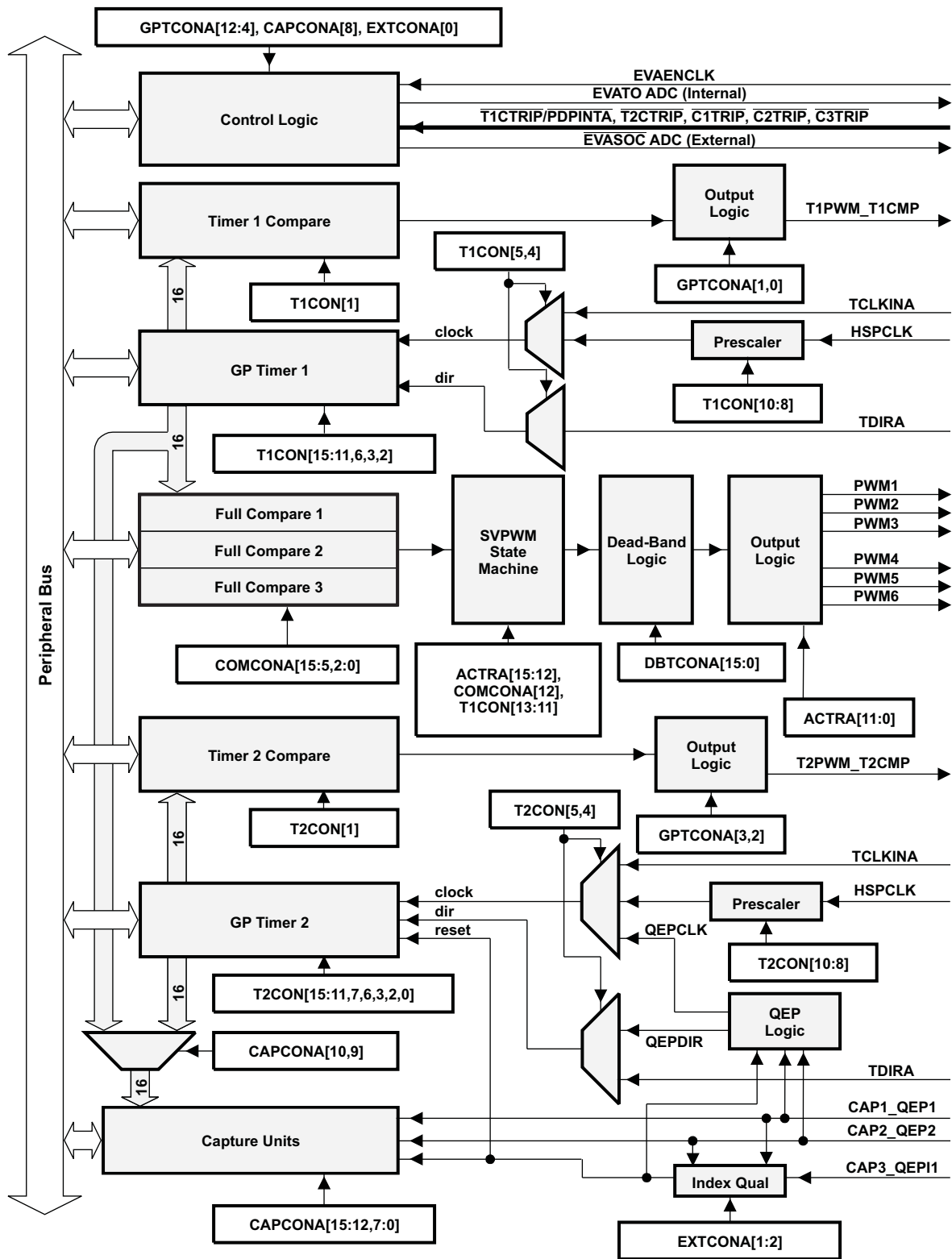

A. The EVB module is similar to the EVA module.

Figure 4-3. Event Manager A Functional Block Diagram

4.2.1 General-Purpose (GP) Timers

There are two GP timers. The GP timer x (x = 1 or 2 for EVA; x = 3 or 4 for EVB) includes:

- A 16-bit timer, up-/down-counter, TxCNT, for reads or writes
- A 16-bit timer-compare register, TxCMPR (double-buffered with shadow register), for reads or writes
- A 16-bit timer-period register, TxPR (double-buffered with shadow register), for reads or writes
- A 16-bit timer-control register, TxCON, for reads or writes
- Selectable internal or external input clocks
- A programmable prescaler for internal or external clock inputs
- Control and interrupt logic, for four maskable interrupts: *underflow*, *overflow*, *timer compare*, and *period interrupts*
- A selectable direction input pin (TDIRx) (to count up or down when directional up-/down-count mode is selected)

The GP timers can be operated independently or synchronized with each other. The compare register associated with each GP timer can be used for compare function and PWM-waveform generation. There are three continuous modes of operations for each GP timer in up- or up/down-counting operations. Internal or external input clocks with programmable prescaler are used for each GP timer. GP timers also provide the time base for the other event-manager submodules: GP timer 1 for all the compares and PWM circuits, GP timer 2/1 for the capture units and the quadrature-pulse counting operations. Double-buffering of the period and compare registers allows programmable change of the timer (PWM) period and the compare/PWM pulse width as needed.

4.2.2 Full-Compare Units

There are three full-compare units on each event manager. These compare units use GP timer1 as the time base and generate six outputs for compare and PWM-waveform generation using programmable deadband circuit. The state of each of the six outputs is configured independently. The compare registers of the compare units are double-buffered, allowing programmable change of the compare/PWM pulse widths as needed.

4.2.3 Programmable Deadband Generator

Deadband generation can be enabled/disabled for each compare unit output individually. The deadband-generator circuit produces two outputs (with or without deadband zone) for each compare unit output signal. The output states of the deadband generator are configurable and changeable as needed by way of the double-buffered ACTRx register.

4.2.4 PWM Waveform Generation

Up to eight PWM waveforms (outputs) can be generated simultaneously by each event manager: three independent pairs (six outputs) by the three full-compare units with *programmable deadbands*, and two independent PWMs by the GP-timer compares.

4.2.5 Double Update PWM Mode

The F281x and C281x Event Manager supports “Double Update PWM Mode.” This mode refers to a PWM operation mode in which the position of the leading edge and the position of the trailing edge of a PWM pulse are independently modifiable in each PWM period. To support this mode, the compare register that determines the position of the edges of a PWM pulse must allow (buffered) compare value update once at the beginning of a PWM period and another time in the middle of a PWM period. The compare registers in F281x and C281x Event Managers are all buffered and support three compare value reload/update (value in buffer becoming active) modes. These modes have earlier been documented as compare value reload conditions. The reload condition that supports double update PWM mode is reloaded on Underflow (beginning of PWM period) OR Period (middle of PWM period). Double update PWM mode can be achieved by using this condition for compare value reload.

4.2.6 PWM Characteristics

Characteristics of the PWMs are as follows:

- 16-bit registers
- Wide range of programmable deadband for the PWM output pairs
- Change of the PWM carrier frequency for PWM frequency wobbling as needed
- Change of the PWM pulse widths within and after each PWM period as needed
- External-maskable power and drive-protection interrupts
- Pulse-pattern-generator circuit, for programmable generation of asymmetric, symmetric, and four-space vector PWM waveforms
- Minimized CPU overhead using auto-reload of the compare and period registers
- The PWM pins are driven to a high-impedance state when the $\overline{\text{PDPINTx}}$ pin is driven low and **after** $\overline{\text{PDPINTx}}$ signal qualification. The $\overline{\text{PDPINTx}}$ pin (after qualification) is reflected in bit 8 of the COMCONx register.
 - $\overline{\text{PDPINTA}}$ pin status is reflected in bit 8 of COMCONA register.
 - $\overline{\text{PDPINTB}}$ pin status is reflected in bit 8 of COMCONB register.
- EXTCON register bits provide options to individually trip control for each PWM pair of signals

4.2.7 Capture Unit

The capture unit provides a logging function for different events or transitions. The values of the selected GP timer counter is captured and stored in the two-level-deep FIFO stacks when selected transitions are detected on capture input pins, CAPx (x = 1, 2, or 3 for EVA; and x = 4, 5, or 6 for EVB). The capture unit consists of three capture circuits.

Capture units include the following features:

- One 16-bit capture control register, CAPCONx (R/W)
- One 16-bit capture FIFO status register, CAPFIFOx
- Selection of GP timer 1/2 (for EVA) or 3/4 (for EVB) as the time base
- Three 16-bit 2-level-deep FIFO stacks, one for each capture unit
- Three capture input pins (CAP1/2/3 for EVA, CAP4/5/6 for EVB)—one input pin per capture unit. [All inputs are synchronized with the device (CPU) clock. In order for a transition to be captured, the input must hold at its current level to meet the input qualification circuitry requirements. The input pins CAP1/2 and CAP4/5 can also be used as QEP inputs to the QEP circuit.]
- User-specified transition (rising edge, falling edge, or both edges) detection
- Three maskable interrupt flags, one for each capture unit
- The capture pins can also be used as general-purpose interrupt pins, if they are not used for the capture function.

4.2.8 Quadrature-Encoder Pulse (QEP) Circuit

Two capture inputs (CAP1 and CAP2 for EVA; CAP4 and CAP5 for EVB) can be used to interface the on-chip QEP circuit with a quadrature encoder pulse. Full synchronization of these inputs is performed on-chip. Direction or leading-quadrature pulse sequence is detected, and GP timer 2/4 is incremented or decremented by the rising and falling edges of the two input signals (four times the frequency of either input pulse).

With EXTCONA register bits, the EVA QEP circuit can use CAP3 as a capture index pin as well. Similarly, with EXTCONB register bits, the EVB QEP circuit can use CAP6 as a capture index pin.

4.2.9 External ADC Start-of-Conversion

EVA/EVB start-of-conversion (SOC) can be sent to an external pin ($\overline{\text{EVASOC}}/\overline{\text{EVBSOC}}$) for external ADC interface. $\overline{\text{EVASOC}}$ and $\overline{\text{EVBSOC}}$ are MUXed with $\overline{\text{T2CTRIP}}$ and $\overline{\text{T4CTRIP}}$, respectively.

4.3 Enhanced Analog-to-Digital Converter (ADC) Module

A simplified functional block diagram of the ADC module is shown in [Figure 4-4](#). The ADC module consists of a 12-bit ADC with a built-in sample-and-hold (S/H) circuit. Functions of the ADC module include:

- 12-bit ADC core with built-in S/H
- Analog input: 0.0 V to 3.0 V (voltages above 3.0 V produce full-scale conversion results)
- Fast conversion rate: 80 ns at 25-MHz ADC clock, 12.5 MSPS
- 16-channel, MUXed inputs
- Autosequencing capability provides up to 16 “autoconversions” in a single session. Each conversion can be programmed to select any 1 of 16 input channels
- Sequencer can be operated as two independent 8-state sequencers or as one large 16-state sequencer (that is, two cascaded 8-state sequencers)
- Sixteen result registers (individually addressable) to store conversion values
 - The digital value of the input analog voltage is derived by:

Digital Value = 0, when input ≤ 0 V

Digital Value = $4096 \times \frac{\text{Input Analog Voltage} - \text{ADCLO}}{3}$ when 0 V < input < 3 V

Digital Value = 4095, when input ≥ 3 V

- Multiple triggers as sources for the start-of-conversion (SOC) sequence
 - S/W – software immediate start
 - EVA – Event manager A (multiple event sources within EVA)
 - EVB – Event manager B (multiple event sources within EVB)
- Flexible interrupt control allows interrupt request on every end-of-sequence (EOS) or every other EOS
- Sequencer can operate in “start/stop” mode, allowing multiple “time-sequenced triggers” to synchronize conversions
- EVA and EVB triggers can operate independently in dual-sequencer mode
- Sample-and-hold (S/H) acquisition time window has separate prescale control

The ADC module in the F281x and C281x has been enhanced to provide flexible interface to event managers A and B. The ADC interface is built around a fast, 12-bit ADC module with a fast conversion rate of 80 ns at 25-MHz ADC clock. The ADC module has 16 channels, configurable as two independent 8-channel modules to service event managers A and B. The two independent 8-channel modules can be cascaded to form a 16-channel module. Although there are multiple input channels and two sequencers, there is only one converter in the ADC module. [Figure 4-4](#) shows the block diagram of the F281x and C281x ADC module.

The two 8-channel modules have the capability to autosequence a series of conversions, each module has the choice of selecting any one of the respective eight channels available through an analog MUX. In the cascaded mode, the autosequencer functions as a single 16-channel sequencer. On each sequencer, once the conversion is complete, the selected channel value is stored in its respective RESULT register. Autosequencing allows the system to convert the same channel multiple times, allowing the user to perform oversampling algorithms. This gives increased resolution over traditional single-sampled conversion results.

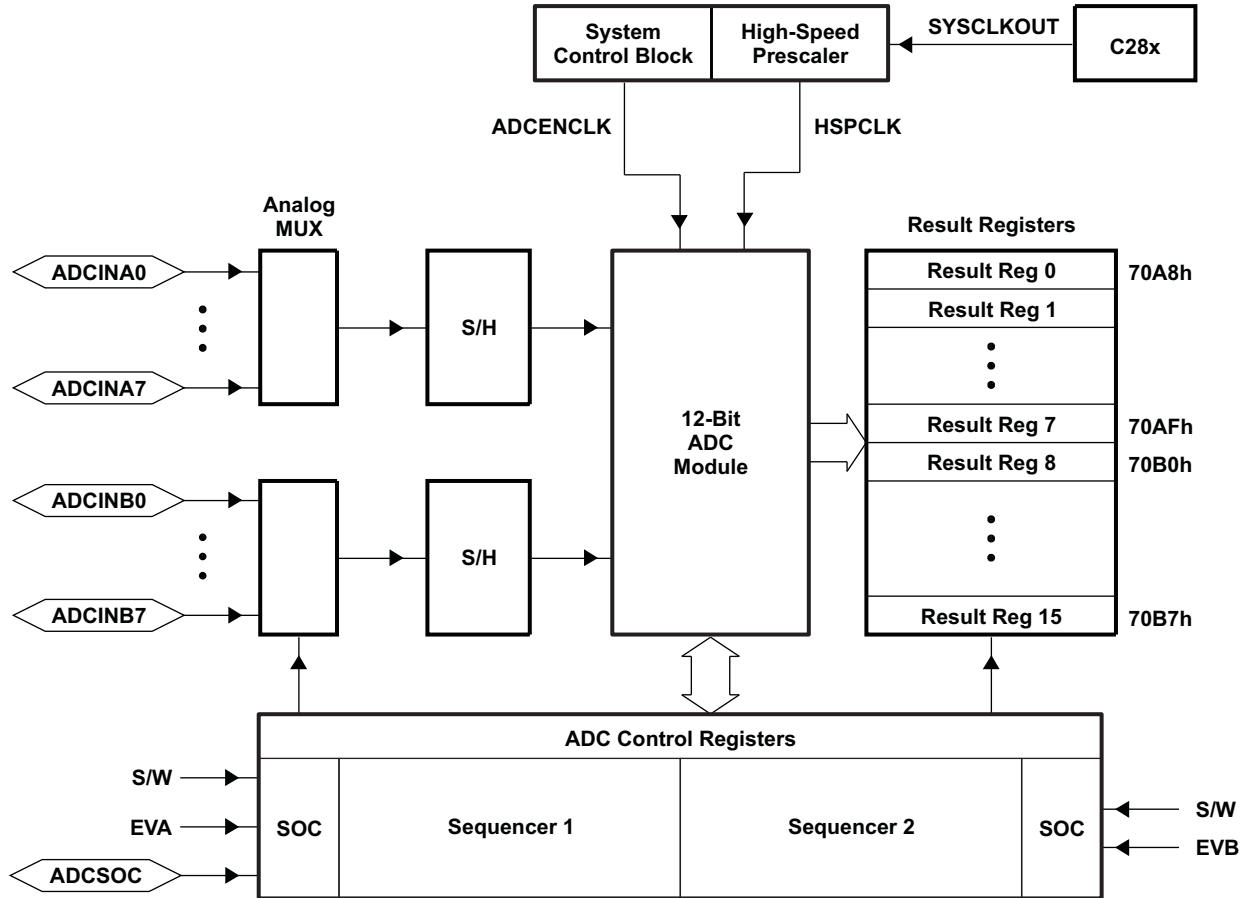

Figure 4-4. Block Diagram of the F281x and C281x ADC Module

To obtain the specified accuracy of the ADC, proper board layout is critical. To the best extent possible, traces leading to the ADCIN pins should not run in close proximity to the digital signal paths. This is to minimize switching noise on the digital lines from getting coupled to the ADC inputs. Furthermore, proper isolation techniques must be used to isolate the ADC module power pins (V_{DDA1}/V_{DDA2} , $AVDDREFBG$) from the digital supply. For better accuracy and ESD protection, unused ADC inputs should be connected to analog ground.

Notes:

1. The ADC registers are accessed at the SYSCLKOUT rate. The internal timing of the ADC module is controlled by the high-speed peripheral clock (HSPCLK).
2. The behavior of the ADC module based on the state of the ADCENCLK and HALT signals is as follows:

ADCENCLK: On reset, this signal will be low. While reset is active-low (\overline{XRS}) the clock to the register will still function. This is necessary to make sure all registers and modes go into their default reset state. The analog module will, however, be in a low-power inactive state. As soon as reset goes high, then the clock to the registers will be disabled. When the user sets the ADCENCLK signal high, then the clocks to the registers will be enabled and the analog module will be enabled. There will be a certain time delay (ms range) before the ADC is stable and can be used.

HALT: This signal only affects the analog module. It does not affect the registers. If low, the ADC module is powered. If high, the ADC module goes into low-power mode. The HALT mode will stop the clock to the CPU, which will stop the HSPCLK. Therefore the ADC register logic will be turned off indirectly.

Figure 4-5 shows the ADC pin-biasing for internal reference and Figure 4-6 shows the ADC pin-biasing for external reference.

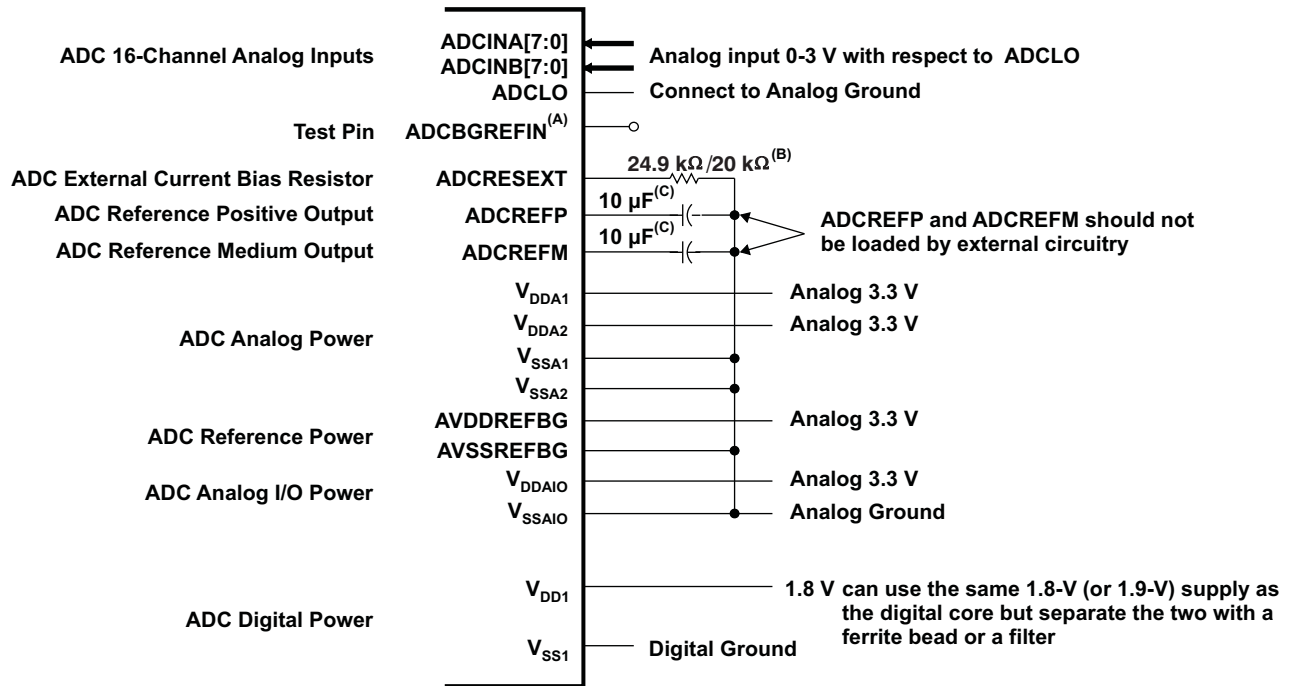

- A. Provide access to this pin in PCB layouts. Intended for test purposes only.
- B. Use 24.9 kΩ for ADC clock range 1–18.75 MHz; use 20 kΩ for ADC clock range 18.75–25 MHz.
- C. TAIYO YUDEN EMK325F106ZH, EMK325BJ106MD, or equivalent ceramic capacitor
- D. External decoupling capacitors are recommended on all power pins.
- E. Analog inputs must be driven from an operational amplifier that does not degrade the ADC performance.

Figure 4-5. ADC Pin Connections With Internal Reference

NOTE

The temperature rating of any recommended component must match the rating of the end product.

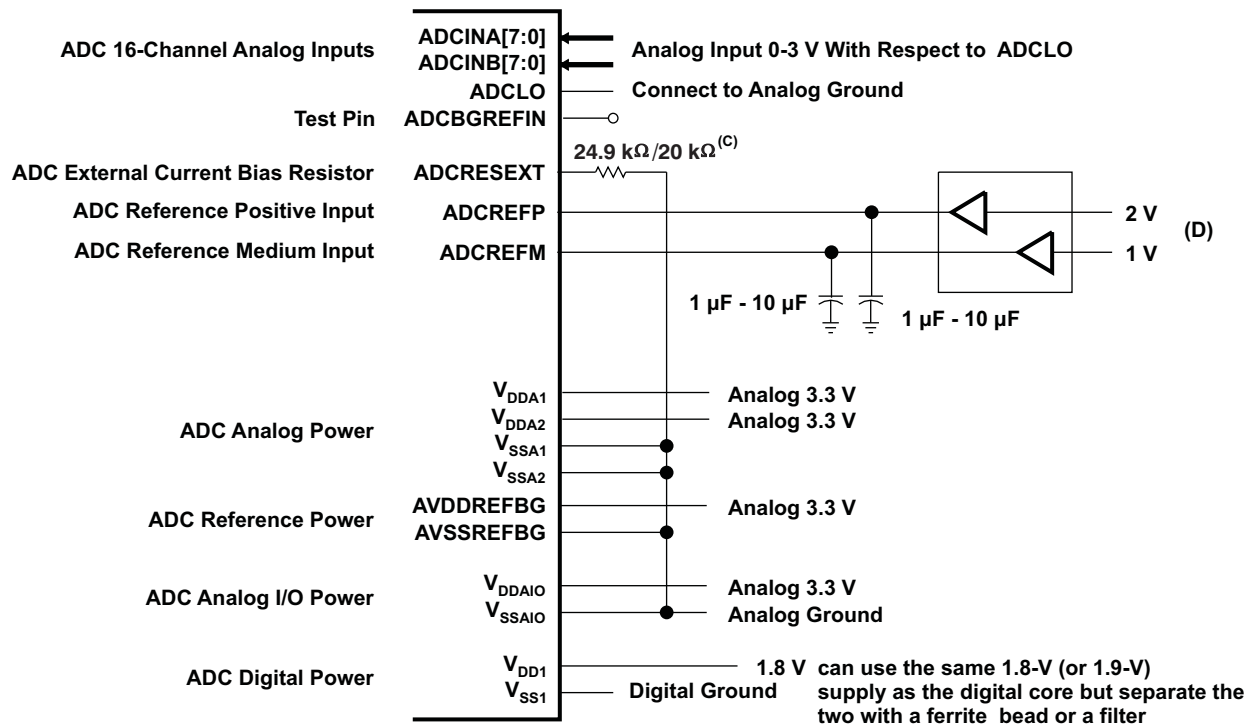

- A. External decoupling capacitors are recommended on all power pins.
- B. Analog inputs must be driven from an operational amplifier that does not degrade the ADC performance.
- C. Use 24.9 kΩ for ADC clock range 1–18.75 MHz; use 20 kΩ for ADC clock range 18.75–25 MHz.
- D. It is recommended that buffered external references be provided with a voltage difference of (ADCREFP – ADCREFM) = 1 V ± 0.1% or better.
 External reference is enabled using bit 8 in the ADCTRL3 Register at ADC power up. In this mode, the accuracy of external reference is critical for overall gain. The voltage ADCREFP – ADCREFM will determine the overall accuracy. Do not enable internal references when external references are connected to ADCREFP and ADCREFM. See the *TMS320x281x DSP Analog-to-Digital Converter (ADC) Reference Guide* (literature number [SPRU060](#)) for more information.

Figure 4-6. ADC Pin Connections With External Reference

The ADC operation is configured, controlled, and monitored by the registers listed in [Table 4-4](#).

Table 4-4. ADC Registers⁽¹⁾

| NAME | ADDRESS | SIZE (x16) | DESCRIPTION |
|--------------|-----------------------|------------|--|
| ADCTRL1 | 0x00 7100 | 1 | ADC Control Register 1 |
| ADCTRL2 | 0x00 7101 | 1 | ADC Control Register 2 |
| ADCMAXCONV | 0x00 7102 | 1 | ADC Maximum Conversion Channels Register |
| ADCCHSELSEQ1 | 0x00 7103 | 1 | ADC Channel Select Sequencing Control Register 1 |
| ADCCHSELSEQ2 | 0x00 7104 | 1 | ADC Channel Select Sequencing Control Register 2 |
| ADCCHSELSEQ3 | 0x00 7105 | 1 | ADC Channel Select Sequencing Control Register 3 |
| ADCCHSELSEQ4 | 0x00 7106 | 1 | ADC Channel Select Sequencing Control Register 4 |
| ADCASEQSR | 0x00 7107 | 1 | ADC Auto-Sequence Status Register |
| ADCRESULT0 | 0x00 7108 | 1 | ADC Conversion Result Buffer Register 0 |
| ADCRESULT1 | 0x00 7109 | 1 | ADC Conversion Result Buffer Register 1 |
| ADCRESULT2 | 0x00 710A | 1 | ADC Conversion Result Buffer Register 2 |
| ADCRESULT3 | 0x00 710B | 1 | ADC Conversion Result Buffer Register 3 |
| ADCRESULT4 | 0x00 710C | 1 | ADC Conversion Result Buffer Register 4 |
| ADCRESULT5 | 0x00 710D | 1 | ADC Conversion Result Buffer Register 5 |
| ADCRESULT6 | 0x00 710E | 1 | ADC Conversion Result Buffer Register 6 |
| ADCRESULT7 | 0x00 710F | 1 | ADC Conversion Result Buffer Register 7 |
| ADCRESULT8 | 0x00 7110 | 1 | ADC Conversion Result Buffer Register 8 |
| ADCRESULT9 | 0x00 7111 | 1 | ADC Conversion Result Buffer Register 9 |
| ADCRESULT10 | 0x00 7112 | 1 | ADC Conversion Result Buffer Register 10 |
| ADCRESULT11 | 0x00 7113 | 1 | ADC Conversion Result Buffer Register 11 |
| ADCRESULT12 | 0x00 7114 | 1 | ADC Conversion Result Buffer Register 12 |
| ADCRESULT13 | 0x00 7115 | 1 | ADC Conversion Result Buffer Register 13 |
| ADCRESULT14 | 0x00 7116 | 1 | ADC Conversion Result Buffer Register 14 |
| ADCRESULT15 | 0x00 7117 | 1 | ADC Conversion Result Buffer Register 15 |
| ADCTRL3 | 0x00 7118 | 1 | ADC Control Register 3 |
| ADCST | 0x00 7119 | 1 | ADC Status Register |
| Reserved | 0x00 711C – 0x00 711F | 4 | |

(1) The above registers are Peripheral Frame 2 Registers.

4.4 Enhanced Controller Area Network (eCAN) Module

The CAN module has the following features:

- Fully compliant with CAN protocol, version 2.0B
- Supports data rates up to 1 Mbps
- Thirty-two mailboxes, each with the following properties:
 - Configurable as receive or transmit
 - Configurable with standard or extended identifier
 - Has a programmable receive mask
 - Supports data and remote frame
 - Composed of 0 to 8 bytes of data
 - Uses a 32-bit time stamp on receive and transmit message
 - Protects against reception of new message
 - Holds the dynamically programmable priority of transmit message
 - Employs a programmable interrupt scheme with two interrupt levels
 - Employs a programmable alarm on transmission or reception time-out
- Low-power mode
- Programmable wake-up on bus activity
- Automatic reply to a remote request message
- Automatic retransmission of a frame in case of loss of arbitration or error
- 32-bit local network time counter synchronized by a specific message (communication in conjunction with mailbox 16)
- Self-test mode
 - Operates in a loopback mode receiving its own message. A “dummy” acknowledge is provided, thereby eliminating the need for another node to provide the acknowledge bit.

NOTE: For a SYSCLKOUT of 150 MHz, the smallest bit rate possible is 23.4 kbps.

The 28x CAN has passed the conformance test per ISO/DIS 16845. Contact TI for details.

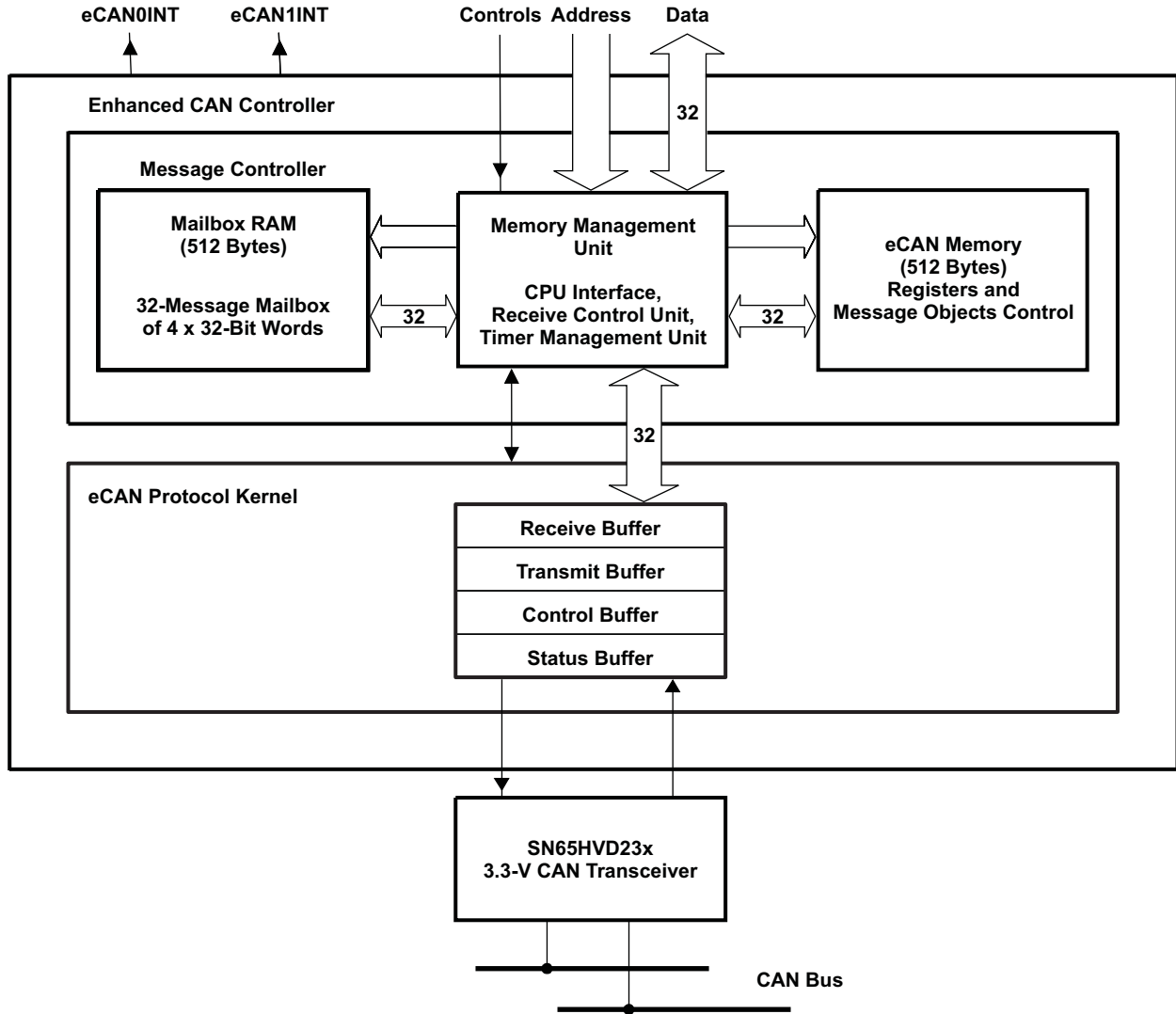

Figure 4-7. eCAN Block Diagram and Interface Circuit

Table 4-5. 3.3-V eCAN Transceivers for the TMS320F281x and TMS320C281x DSPs

| PART NUMBER | SUPPLY VOLTAGE | LOW-POWER MODE | SLOPE CONTROL | VREF | OTHER | T _A |
|-------------|----------------|-------------------|---------------|------|---|----------------|
| SN65HVD230 | 3.3 V | Standby | Adjustable | Yes | – | –40°C to 85°C |
| SN65HVD230Q | 3.3 V | Standby | Adjustable | Yes | – | –40°C to 125°C |
| SN65HVD231 | 3.3 V | Sleep | Adjustable | Yes | – | –40°C to 85°C |
| SN65HVD231Q | 3.3 V | Sleep | Adjustable | Yes | – | –40°C to 125°C |
| SN65HVD232 | 3.3 V | None | None | None | – | –40°C to 85°C |
| SN65HVD232Q | 3.3 V | None | None | None | – | –40°C to 125°C |
| SN65HVD233 | 3.3 V | Standby | Adjustable | None | Diagnostic Loopback | –40°C to 125°C |
| SN65HVD234 | 3.3 V | Standby and Sleep | Adjustable | None | – | –40°C to 125°C |
| SN65HVD235 | 3.3 V | Standby | Adjustable | None | Autobaud Loopback | –40°C to 125°C |
| ISO1050 | 3–5.5 V | None | None | None | Built-in Isolation Low Prop Delay Thermal Shutdown Failsafe Operation Dominant Time-out | –55°C to 105°C |

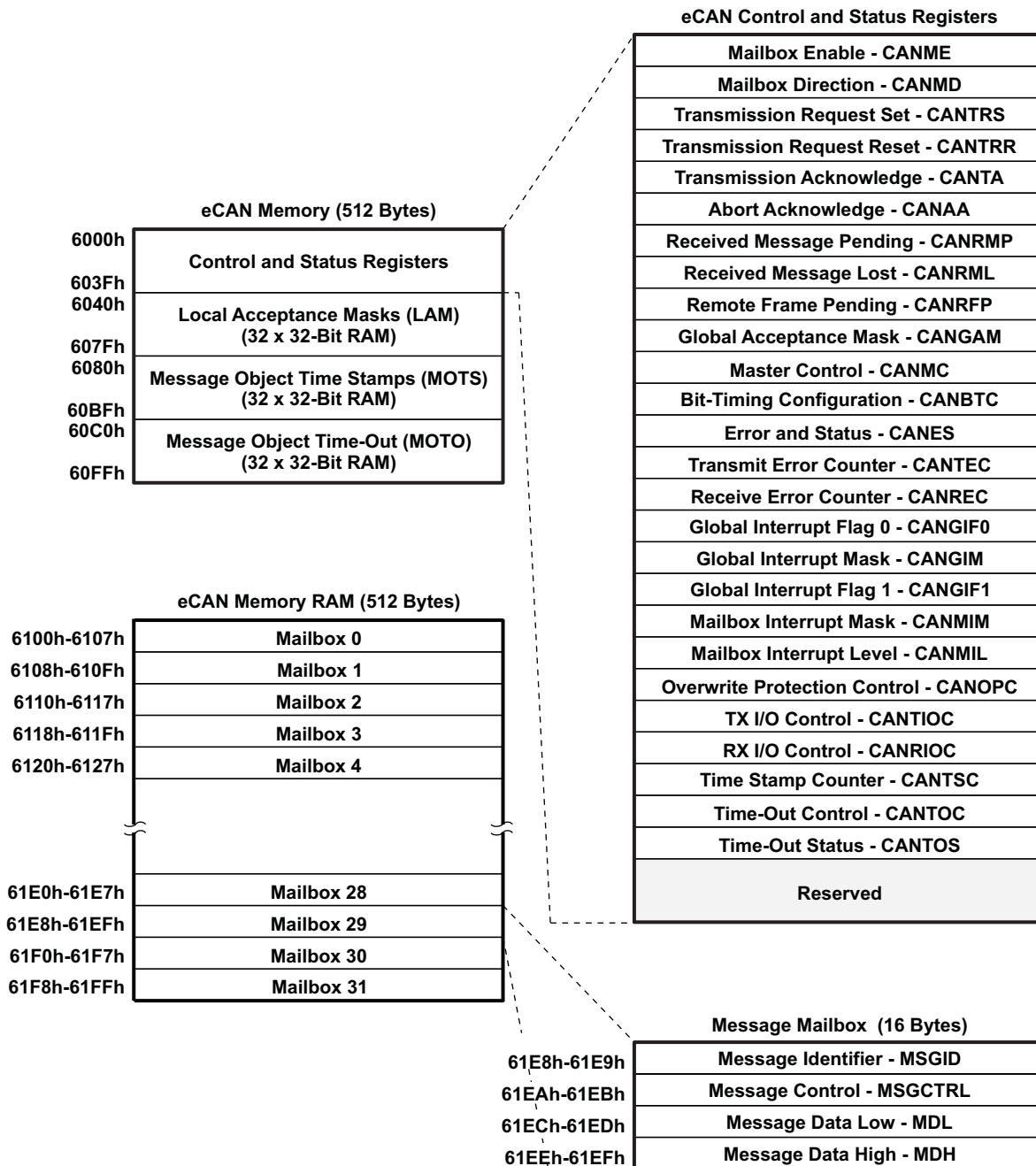

Figure 4-8. eCAN Memory Map

NOTE

If the eCAN module is not used in an application, the RAM available (LAM, MOTS, MOTO, and mailbox RAM) can be used as general-purpose RAM. The CAN module clock should be enabled for this.

The CAN registers listed in [Table 4-6](#) are used by the CPU to configure and control the CAN controller and the message objects. eCAN control registers only support 32-bit read/write operations. Mailbox RAM can be accessed as 16 bits or 32 bits. 32-bit accesses are aligned to an even boundary.

Table 4-6. CAN Registers⁽¹⁾

| NAME | ADDRESS | SIZE (x32) | DESCRIPTION |
|---------|-----------|------------|---|
| CANME | 0x00 6000 | 1 | Mailbox enable |
| CANMD | 0x00 6002 | 1 | Mailbox direction |
| CANTRS | 0x00 6004 | 1 | Transmit request set |
| CANTRR | 0x00 6006 | 1 | Transmit request reset |
| CANTA | 0x00 6008 | 1 | Transmission acknowledge |
| CANAA | 0x00 600A | 1 | Abort acknowledge |
| CANRMP | 0x00 600C | 1 | Receive message pending |
| CANRML | 0x00 600E | 1 | Receive message lost |
| CANRFP | 0x00 6010 | 1 | Remote frame pending |
| CANGAM | 0x00 6012 | 1 | Global acceptance mask |
| CANMC | 0x00 6014 | 1 | Master control |
| CANBTC | 0x00 6016 | 1 | Bit-timing configuration |
| CANES | 0x00 6018 | 1 | Error and status |
| CANTEC | 0x00 601A | 1 | Transmit error counter |
| CANREC | 0x00 601C | 1 | Receive error counter |
| CANGIF0 | 0x00 601E | 1 | Global interrupt flag 0 |
| CANGIM | 0x00 6020 | 1 | Global interrupt mask |
| CANGIF1 | 0x00 6022 | 1 | Global interrupt flag 1 |
| CANMIM | 0x00 6024 | 1 | Mailbox interrupt mask |
| CANMIL | 0x00 6026 | 1 | Mailbox interrupt level |
| CANOPC | 0x00 6028 | 1 | Overwrite protection control |
| CANTIOC | 0x00 602A | 1 | TX I/O control |
| CANRIOC | 0x00 602C | 1 | RX I/O control |
| CANTSC | 0x00 602E | 1 | Time stamp counter (Reserved in SCC mode) |
| CANTOC | 0x00 6030 | 1 | Time-out control (Reserved in SCC mode) |
| CANTOS | 0x00 6032 | 1 | Time-out status (Reserved in SCC mode) |

(1) These registers are mapped to Peripheral Frame 1.

4.5 Multichannel Buffered Serial Port (McBSP) Module

The McBSP module has the following features:

- Compatible to McBSP in TMS320C54x™/ TMS320C55x™ DSP devices, except the DMA features
- Full-duplex communication
- Double-buffered data registers which allow a continuous data stream
- Independent framing and clocking for receive and transmit
- External shift clock generation or an internal programmable frequency shift clock
- A wide selection of data sizes including 8-, 12-, 16-, 20-, 24-, or 32-bits
- 8-bit data transfers with LSB or MSB first
- Programmable polarity for both frame synchronization and data clocks
- Highly programmable internal clock and frame generation
- Support A-bis mode
- Direct interface to industry-standard CODECs, Analog Interface Chips (AICs), and other serially connected A/D and D/A devices
- Works with SPI-compatible devices
- Two 16 x 16-level FIFO for Transmit channel
- Two 16 x 16-level FIFO for Receive channel

The following application interfaces can be supported on the McBSP:

- T1/E1 framers
- MVIP switching-compatible and ST-BUS-compliant devices including:
 - MVIP framers
 - H.100 framers
 - SCSA framers
 - IOM-2 compliant devices
 - AC97-compliant devices (the necessary multiphase frame synchronization capability is provided.)
 - IIS-compliant devices
- McBSP clock rate = $CLKG = \frac{CLKSRG}{(1 + CLKGDIV)}$, where CLKSRG source could be LSPCLK, CLKX, or CLKR. ⁽²⁾

(2) Serial port performance is limited by I/O buffer switching speed. Internal prescalers must be adjusted such that the peripheral speed is less than the I/O buffer speed limit—20-MHz maximum.

Figure 4-9 shows the block diagram of the McBSP module with FIFO, interfaced to the F281x and C281x version of Peripheral Frame 2.

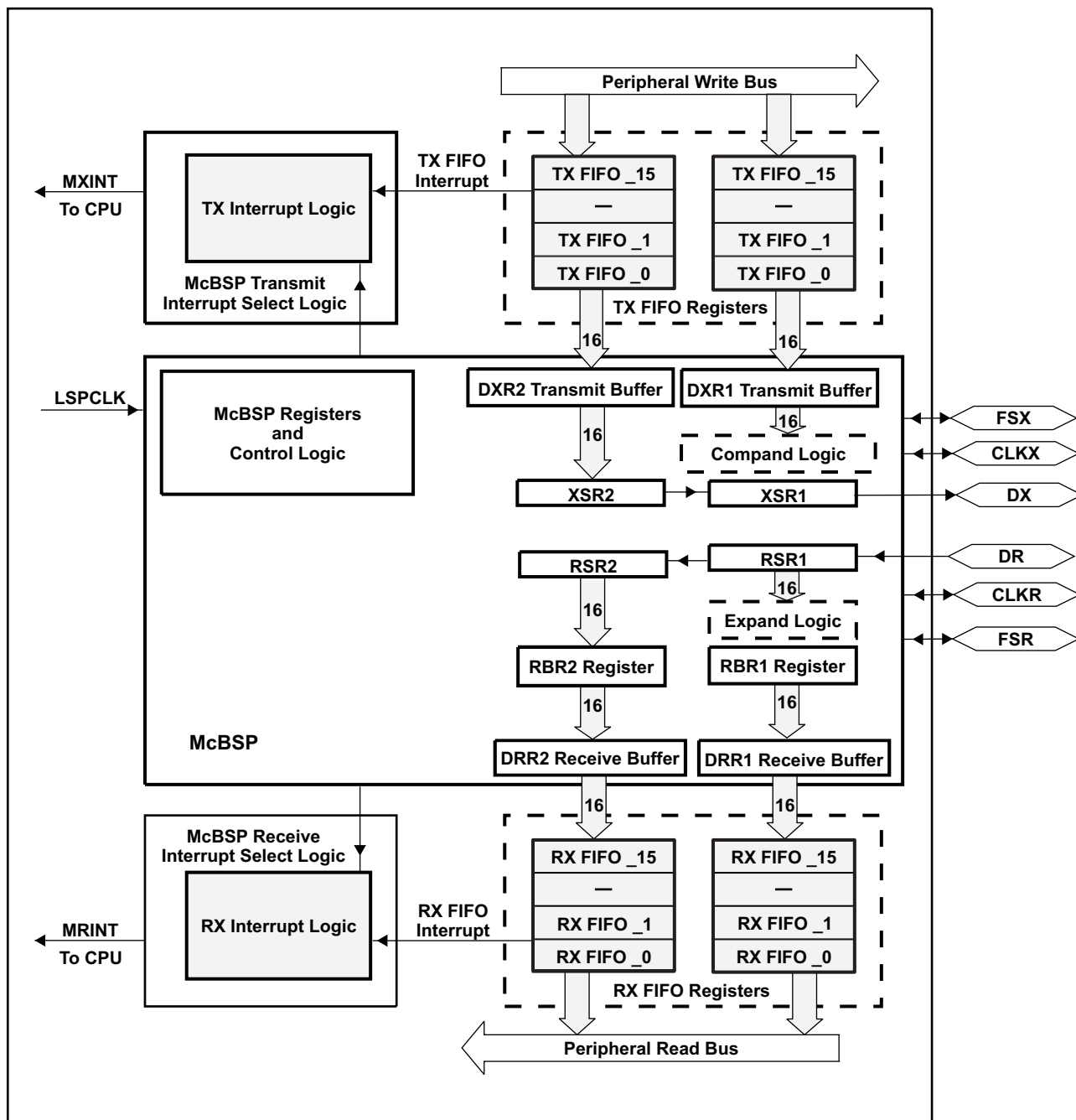

Figure 4-9. McBSP Module With FIFO

Table 4-7 provides a summary of the McBSP registers.

Table 4-7. McBSP Registers

| NAME | ADDRESS 0x00 78xxh | TYPE (R/W) | RESET VALUE (HEX) | DESCRIPTION |
|--|-----------------------|---------------|----------------------|--|
| DATA REGISTERS, RECEIVE, TRANSMIT⁽¹⁾ | | | | |
| – | – | – | 0x0000 | McBSP Receive Buffer Register |
| – | – | – | 0x0000 | McBSP Receive Shift Register |
| – | – | – | 0x0000 | McBSP Transmit Shift Register |
| DRR2 | 00 | R | 0x0000 | McBSP Data Receive Register 2 • Read First if the word size is greater than 16 bits, else ignore DRR2 |
| DRR1 | 01 | R | 0x0000 | McBSP Data Receive Register 1 • Read Second if the word size is greater than 16 bits, else read DRR1 only |
| DXR2 | 02 | W | 0x0000 | McBSP Data Transmit Register 2 • Write First if the word size is greater than 16 bits, else ignore DXR2 |
| DXR1 | 03 | W | 0x0000 | McBSP Data Transmit Register 1 • Write Second if the word size is greater than 16 bits, else write to DXR1 only |
| McBSP CONTROL REGISTERS | | | | |
| SPCR2 | 04 | R/W | 0x0000 | McBSP Serial Port Control Register 2 |
| SPCR1 | 05 | R/W | 0x0000 | McBSP Serial Port Control Register 1 |
| RCR2 | 06 | R/W | 0x0000 | McBSP Receive Control Register 2 |
| RCR1 | 07 | R/W | 0x0000 | McBSP Receive Control Register 1 |
| XCR2 | 08 | R/W | 0x0000 | McBSP Transmit Control Register 2 |
| XCR1 | 09 | R/W | 0x0000 | McBSP Transmit Control Register 1 |
| SRGR2 | 0A | R/W | 0x0000 | McBSP Sample Rate Generator Register 2 |
| SRGR1 | 0B | R/W | 0x0000 | McBSP Sample Rate Generator Register 1 |
| MULTICHANNEL CONTROL REGISTERS | | | | |
| MCR2 | 0C | R/W | 0x0000 | McBSP Multichannel Register 2 |
| MCR1 | 0D | R/W | 0x0000 | McBSP Multichannel Register 1 |
| RCERA | 0E | R/W | 0x0000 | McBSP Receive Channel Enable Register Partition A |
| RCERB | 0F | R/W | 0x0000 | McBSP Receive Channel Enable Register Partition B |
| XCERA | 10 | R/W | 0x0000 | McBSP Transmit Channel Enable Register Partition A |
| XCERB | 11 | R/W | 0x0000 | McBSP Transmit Channel Enable Register Partition B |
| PCR | 12 | R/W | 0x0000 | McBSP Pin Control Register |
| RCERC | 13 | R/W | 0x0000 | McBSP Receive Channel Enable Register Partition C |
| RCERD | 14 | R/W | 0x0000 | McBSP Receive Channel Enable Register Partition D |
| XCERC | 15 | R/W | 0x0000 | McBSP Transmit Channel Enable Register Partition C |
| XCERD | 16 | R/W | 0x0000 | McBSP Transmit Channel Enable Register Partition D |
| RCERE | 17 | R/W | 0x0000 | McBSP Receive Channel Enable Register Partition E |
| RCERF | 18 | R/W | 0x0000 | McBSP Receive Channel Enable Register Partition F |
| XCERE | 19 | R/W | 0x0000 | McBSP Transmit Channel Enable Register Partition E |
| XCERF | 1A | R/W | 0x0000 | McBSP Transmit Channel Enable Register Partition F |
| RCERG | 1B | R/W | 0x0000 | McBSP Receive Channel Enable Register Partition G |
| RCERH | 1C | R/W | 0x0000 | McBSP Receive Channel Enable Register Partition H |
| XCERG | 1D | R/W | 0x0000 | McBSP Transmit Channel Enable Register Partition G |
| XCERH | 1E | R/W | 0x0000 | McBSP Transmit Channel Enable Register Partition H |

(1) DRR2/DRR1 and DXR2/DXR1 share the same addresses of receive and transmit FIFO registers in FIFO mode.

Table 4-7. McBSP Registers (continued)

| NAME | ADDRESS 0x00 78xxh | TYPE (R/W) | RESET VALUE (HEX) | DESCRIPTION |
|---|-----------------------|---------------|----------------------|---|
| FIFO MODE REGISTERS (applicable only in FIFO mode) | | | | |
| FIFO Data Registers⁽²⁾ | | | | |
| DRR2 | 00 | R | 0x0000 | McBSP Data Receive Register 2 – Top of receive FIFO • Read First FIFO pointers will not advance |
| DRR1 | 01 | R | 0x0000 | McBSP Data Receive Register 1 – Top of receive FIFO • Read Second for FIFO pointers to advance |
| DXR2 | 02 | W | 0x0000 | McBSP Data Transmit Register 2 – Top of transmit FIFO • Write First FIFO pointers will not advance |
| DXR1 | 03 | W | 0x0000 | McBSP Data Transmit Register 1 – Top of transmit FIFO • Write Second for FIFO pointers to advance |
| FIFO Control Registers | | | | |
| MFFTX | 20 | R/W | 0xA000 | McBSP Transmit FIFO Register |
| MFFRX | 21 | R/W | 0x201F | McBSP Receive FIFO Register |
| MFFCT | 22 | R/W | 0x0000 | McBSP FIFO Control Register |
| MFFINT | 23 | R/W | 0x0000 | McBSP FIFO Interrupt Register |
| MFFST | 24 | R/W | 0x0000 | McBSP FIFO Status Register |

(2) FIFO pointers advancing is based on order of access to DRR2/DRR1 and DXR2/DXR1 registers.

4.6 Serial Communications Interface (SCI) Module

The F281x and C281x devices include two serial communications interface (SCI) modules. The SCI modules support digital communications between the CPU and other asynchronous peripherals that use the standard non-return-to-zero (NRZ) format. The SCI receiver and transmitter are double-buffered, and each has its own separate enable and interrupt bits. Both can be operated independently or simultaneously in the full-duplex mode. To ensure data integrity, the SCI checks received data for break detection, parity, overrun, and framing errors. The bit rate is programmable to over 65000 different speeds through a 16-bit baud-select register.

Features of each SCI module include:

- Two external pins:
 - SCITXD: SCI transmit-output pin
 - SCIRXD: SCI receive-input pin
- **NOTE:** Both pins can be used as GPIO if not used for SCI.
- Baud rate programmable to 64K different rates ⁽³⁾

$$\begin{aligned} \text{Baud rate} &= \frac{\text{LSPCLK}}{(\text{BRR} + 1) * 8} && \text{when BRR} \neq 0 \\ &= \frac{\text{LSPCLK}}{16} && \text{when BRR} = 0 \end{aligned}$$

- Data-word format
 - One start bit
 - Data-word length programmable from one to eight bits
 - Optional even/odd/no parity bit
 - One or two stop bits
- Four error-detection flags: parity, overrun, framing, and break detection
- Two wake-up multiprocessor modes: idle-line and address bit
- Half- or full-duplex operation
- Double-buffered receive and transmit functions
- Transmitter and receiver operations can be accomplished through interrupt-driven or polled algorithms with status flags.
 - Transmitter: TXRDY flag (transmitter-buffer register is ready to receive another character) and TX EMPTY flag (transmitter-shift register is empty)
 - Receiver: RXRDY flag (receiver-buffer register is ready to receive another character), BRKDT flag (break condition occurred), and RX ERROR flag (monitoring four interrupt conditions)
- Separate enable bits for transmitter and receiver interrupts (except BRKDT)
- Max bit rate = 75 MHz/16 = 4.688 x 10⁶ b/s
- NRZ (non-return-to-zero) format
- Ten SCI module control registers located in the control register frame beginning at address 7050h
 - **NOTE:** All registers in this module are 8-bit registers that are connected to Peripheral Frame 2. When a register is accessed, the register data is in the lower byte (7–0), and the upper byte (15–8) is read as zeros. Writing to the upper byte has no effect.

Enhanced features:

- Auto baud-detect hardware logic
- 16-level transmit/receive FIFO

(3) Serial port performance is limited by I/O buffer switching speed. Internal prescalers must be adjusted such that the peripheral speed is less than the I/O buffer speed limit—20 MHz maximum.

The SCI port operation is configured and controlled by the registers listed in [Table 4-8](#) and [Table 4-9](#).

Table 4-8. SCI-A Registers

| NAME | ADDRESS | SIZE (x16) | DESCRIPTION |
|-------------------------|-----------|------------|--|
| SCICCRRA | 0x00 7050 | 1 | SCI-A Communications Control Register |
| SCICTL1A | 0x00 7051 | 1 | SCI-A Control Register 1 |
| SCIHBAUDA | 0x00 7052 | 1 | SCI-A Baud Register, High Bits |
| SCILBAUDA | 0x00 7053 | 1 | SCI-A Baud Register, Low Bits |
| SCICTL2A | 0x00 7054 | 1 | SCI-A Control Register 2 |
| SCIRXSTA | 0x00 7055 | 1 | SCI-A Receive Status Register |
| SCIRXEMUA | 0x00 7056 | 1 | SCI-A Receive Emulation Data Buffer Register |
| SCIRXBUFA | 0x00 7057 | 1 | SCI-A Receive Data Buffer Register |
| SCITXBUFA | 0x00 7059 | 1 | SCI-A Transmit Data Buffer Register |
| SCIFFTXA ⁽¹⁾ | 0x00 705A | 1 | SCI-A FIFO Transmit Register |
| SCIFFRXA ⁽¹⁾ | 0x00 705B | 1 | SCI-A FIFO Receive Register |
| SCIFFCTA ⁽¹⁾ | 0x00 705C | 1 | SCI-A FIFO Control Register |
| SCIPRIA | 0x00 705F | 1 | SCI-A Priority Control Register |

(1) These registers are new registers for the FIFO mode.

Table 4-9. SCI-B Registers⁽¹⁾

| NAME | ADDRESS | SIZE (x16) | DESCRIPTION |
|-------------------------|-----------|------------|--|
| SCICCRB | 0x00 7750 | 1 | SCI-B Communications Control Register |
| SCICTL1B | 0x00 7751 | 1 | SCI-B Control Register 1 |
| SCIHBAUDB | 0x00 7752 | 1 | SCI-B Baud Register, High Bits |
| SCILBAUDB | 0x00 7753 | 1 | SCI-B Baud Register, Low Bits |
| SCICTL2B | 0x00 7754 | 1 | SCI-B Control Register 2 |
| SCIRXSTB | 0x00 7755 | 1 | SCI-B Receive Status Register |
| SCIRXEMUB | 0x00 7756 | 1 | SCI-B Receive Emulation Data Buffer Register |
| SCIRXBUFB | 0x00 7757 | 1 | SCI-B Receive Data Buffer Register |
| SCITXBUFB | 0x00 7759 | 1 | SCI-B Transmit Data Buffer Register |
| SCIFFTXB ⁽²⁾ | 0x00 775A | 1 | SCI-B FIFO Transmit Register |
| SCIFFRXB ⁽²⁾ | 0x00 775B | 1 | SCI-B FIFO Receive Register |
| SCIFFCTB ⁽²⁾ | 0x00 775C | 1 | SCI-B FIFO Control Register |
| SCIPRIB | 0x00 775F | 1 | SCI-B Priority Control Register |

(1) Registers in this table are mapped to peripheral bus 16 space. This space only allows 16-bit accesses. 32-bit accesses produce undefined results.

(2) These registers are new registers for the FIFO mode.

Figure 4-10 shows the SCI module block diagram.

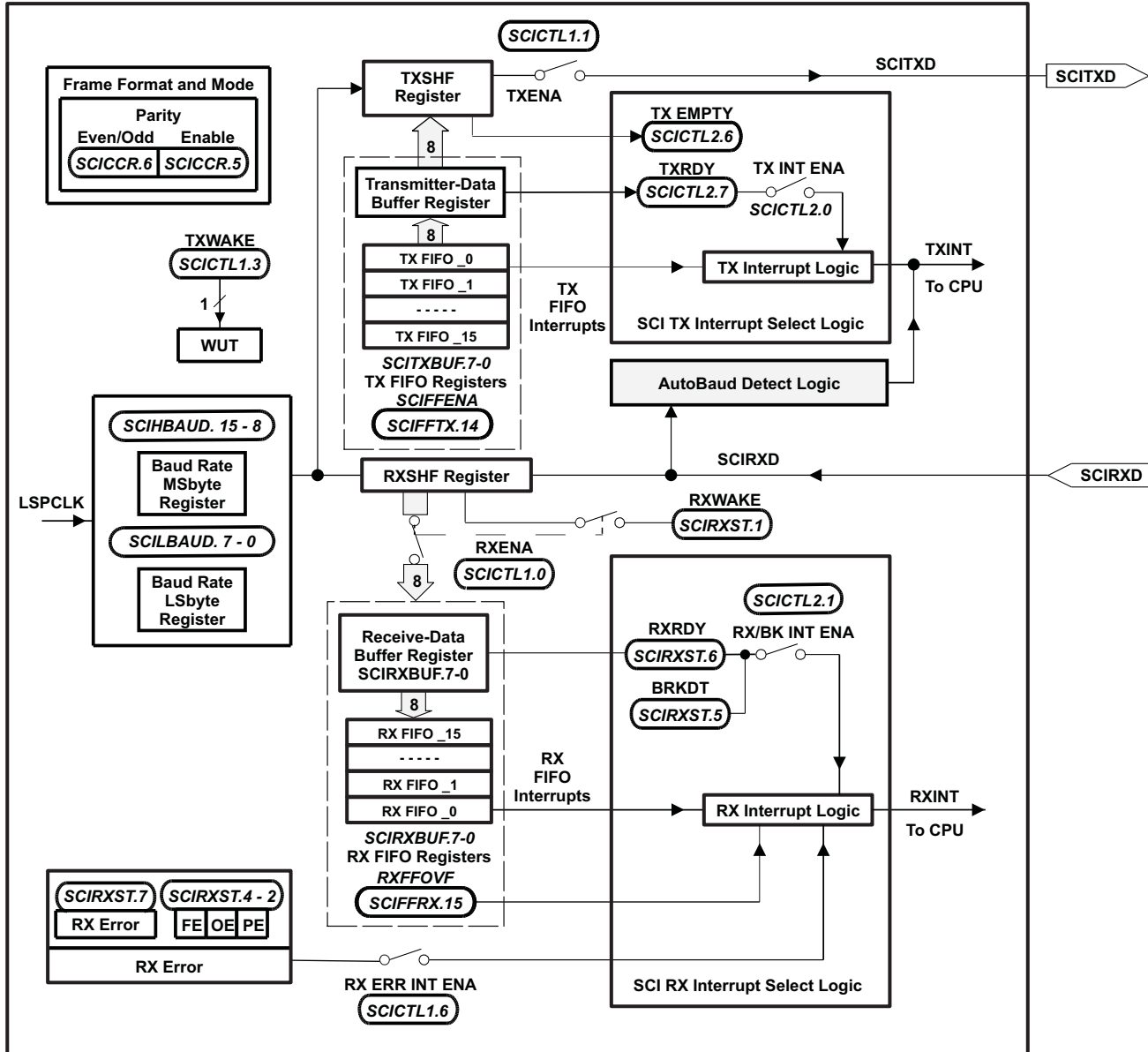

Figure 4-10. Serial Communications Interface (SCI) Module Block Diagram

4.7 Serial Peripheral Interface (SPI) Module

The F281x and C281x devices include the four-pin serial peripheral interface (SPI) module. The SPI is a high-speed, synchronous serial I/O port that allows a serial bit stream of programmed length (one to sixteen bits) to be shifted into and out of the device at a programmable bit-transfer rate. Normally, the SPI is used for communications between the DSP controller and external peripherals or another processor. Typical applications include external I/O or peripheral expansion through devices such as shift registers, display drivers, and ADCs. Multidevice communications are supported by the master/slave operation of the SPI.

The SPI module features include:

- Four external pins:
 - SPISOMI: SPI slave-output/master-input pin
 - SPISIMO: SPI slave-input/master-output pin
 - $\overline{\text{SPISTE}}$: SPI slave transmit-enable pin
 - SPICLK: SPI serial-clock pin

NOTE: All four pins can be used as GPIO, if the SPI module is not used.
- Two operational modes: master and slave
- Baud rate: 125 different programmable rates

$$\begin{aligned} \text{Baud rate} &= \frac{\text{LSPCLK}}{(\text{SPIBRR} + 1)} && \text{when SPIBRR} \neq 0 \\ &= \frac{\text{LSPCLK}}{4} && \text{when SPIBRR} = 0, 1, 2, 3 \end{aligned}$$

Serial port performance is limited by I/O buffer switching speed. Internal prescalers must be adjusted such that the peripheral speed is less than the I/O buffer speed limit—20 MHz maximum.

- Data word length: one to sixteen data bits
- Four clocking schemes (controlled by clock polarity and clock phase bits) include:
 - Falling edge without phase delay: SPICLK active-high. SPI transmits data on the falling edge of the SPICLK signal and receives data on the rising edge of the SPICLK signal.
 - Falling edge with phase delay: SPICLK active-high. SPI transmits data one half-cycle ahead of the falling edge of the SPICLK signal and receives data on the falling edge of the SPICLK signal.
 - Rising edge without phase delay: SPICLK inactive-low. SPI transmits data on the rising edge of the SPICLK signal and receives data on the falling edge of the SPICLK signal.
 - Rising edge with phase delay: SPICLK inactive-low. SPI transmits data one half-cycle ahead of the falling edge of the SPICLK signal and receives data on the rising edge of the SPICLK signal.
- Simultaneous receive and transmit operation (transmit function can be disabled in software)
- Transmitter and receiver operations are accomplished through either interrupt-driven or polled algorithms.
- Nine SPI module control registers: Located in control register frame beginning at address 7040h.

NOTE: All registers in this module are 16-bit registers that are connected to Peripheral Frame 2. When a register is accessed, the register data is in the lower byte (7–0), and the upper byte (15–8) is read as zeros. Writing to the upper byte has no effect.

Enhanced features:

- 16-level transmit/receive FIFO
- Delayed transmit control

The SPI port operation is configured and controlled by the registers listed in [Table 4-10](#).

Table 4-10. SPI Registers⁽¹⁾

| NAME | ADDRESS | SIZE (x16) | DESCRIPTION |
|----------|-----------|------------|---------------------------------------|
| SPICCR | 0x00 7040 | 1 | SPI Configuration Control Register |
| SPICTL | 0x00 7041 | 1 | SPI Operation Control Register |
| SPISTS | 0x00 7042 | 1 | SPI Status Register |
| SPIBRR | 0x00 7044 | 1 | SPI Baud Rate Register |
| SPIRXEMU | 0x00 7046 | 1 | SPI Receive Emulation Buffer Register |
| SPIRXBUF | 0x00 7047 | 1 | SPI Serial Input Buffer Register |
| SPITXBUF | 0x00 7048 | 1 | SPI Serial Output Buffer Register |
| SPIDAT | 0x00 7049 | 1 | SPI Serial Data Register |
| SPIFFTX | 0x00 704A | 1 | SPI FIFO Transmit Register |
| SPIFFRX | 0x00 704B | 1 | SPI FIFO Receive Register |
| SPIFFCT | 0x00 704C | 1 | SPI FIFO Control Register |
| SPIPRI | 0x00 704F | 1 | SPI Priority Control Register |

(1) These registers are mapped to Peripheral Frame 2. This space only allows 16-bit accesses. 32-bit accesses produce undefined results.

Figure 4-11 is a block diagram of the SPI in slave mode.

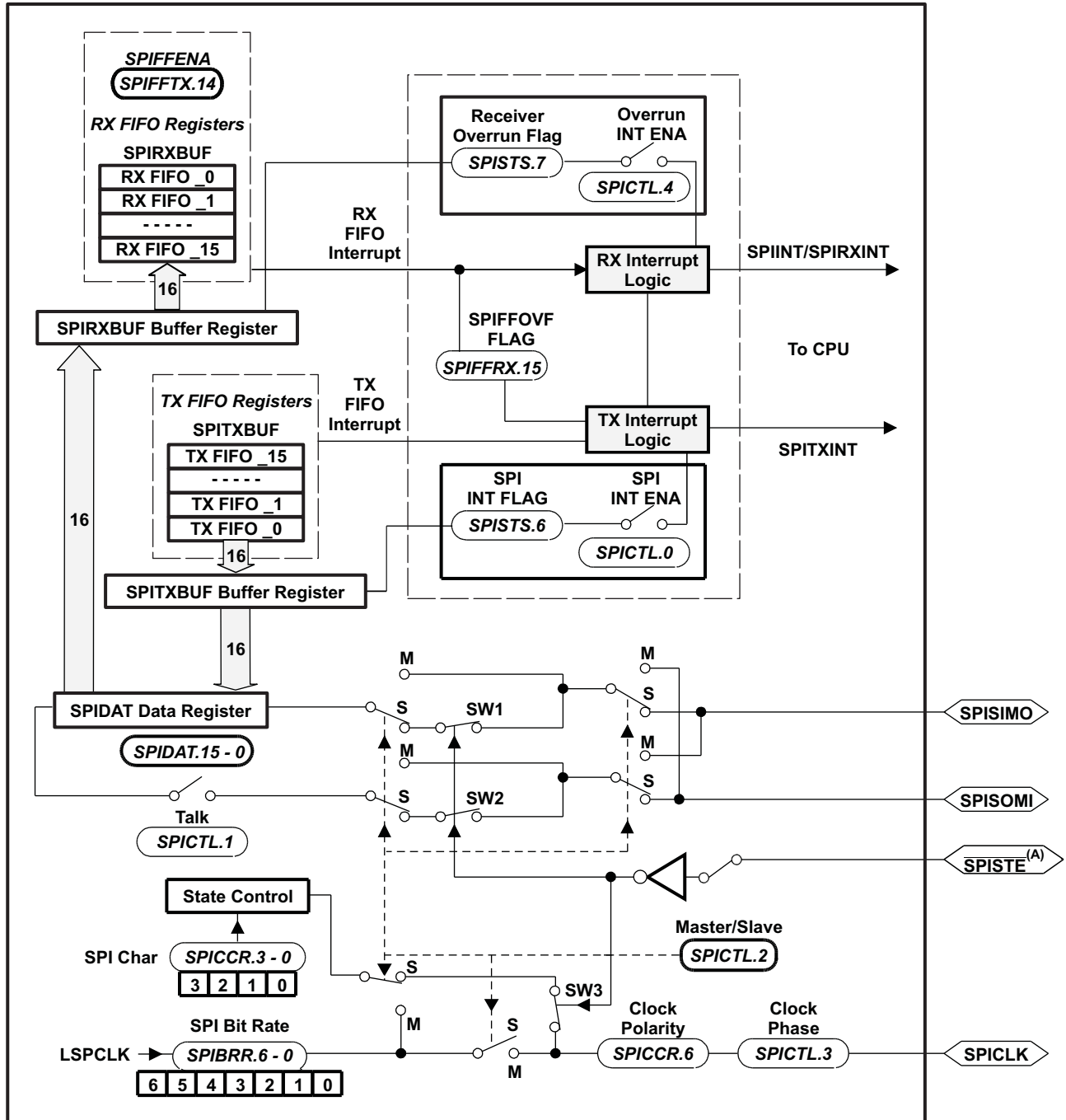

A. SPISTE is driven low by the master for a slave device.

Figure 4-11. Serial Peripheral Interface Module Block Diagram (Slave Mode)

4.8 GPIO MUX

The GPIO Mux registers are used to select the operation of shared pins on the F281x and C281x devices. The pins can be individually selected to operate as “Digital I/O” or connected to “Peripheral I/O” signals (via the GPxMUX registers). If selected for “Digital I/O” mode, registers are provided to configure the pin direction (via the GPxDIR registers) and to qualify the input signal to remove unwanted noise (via the GPxQUAL registers). [Table 4-11](#) lists the GPIO Mux Registers.

Table 4-11. GPIO Mux Registers⁽¹⁾⁽²⁾⁽³⁾

| NAME | ADDRESS | SIZE (x16) | DESCRIPTION |
|----------|-----------------------|------------|---|
| GPAMUX | 0x00 70C0 | 1 | GPIO A Mux Control Register |
| GPADIR | 0x00 70C1 | 1 | GPIO A Direction Control Register |
| GPAQUAL | 0x00 70C2 | 1 | GPIO A Input Qualification Control Register |
| Reserved | 0x00 70C3 | 1 | |
| GPBMUX | 0x00 70C4 | 1 | GPIO B Mux Control Register |
| GPBDIR | 0x00 70C5 | 1 | GPIO B Direction Control Register |
| GPBQUAL | 0x00 70C6 | 1 | GPIO B Input Qualification Control Register |
| Reserved | 0x00 70C7 | 1 | |
| Reserved | 0x00 70C8 | 1 | |
| Reserved | 0x00 70C9 | 1 | |
| Reserved | 0x00 70CA | 1 | |
| Reserved | 0x00 70CB | 1 | |
| GPDMUX | 0x00 70CC | 1 | GPIO D Mux Control Register |
| GPDDIR | 0x00 70CD | 1 | GPIO D Direction Control Register |
| GPDQUAL | 0x00 70CE | 1 | GPIO D Input Qualification Control Register |
| Reserved | 0x00 70CF | 1 | |
| GPEMUX | 0x00 70D0 | 1 | GPIO E Mux Control Register |
| GPEDIR | 0x00 70D1 | 1 | GPIO E Direction Control Register |
| GPEQUAL | 0x00 70D2 | 1 | GPIO E Input Qualification Control Register |
| Reserved | 0x00 70D3 | 1 | |
| GPFMUX | 0x00 70D4 | 1 | GPIO F Mux Control Register |
| GPFDIR | 0x00 70D5 | 1 | GPIO F Direction Control Register |
| Reserved | 0x00 70D6 | 1 | |
| Reserved | 0x00 70D7 | 1 | |
| GPGMUX | 0x00 70D8 | 1 | GPIO G Mux Control Register |
| GPGDIR | 0x00 70D9 | 1 | GPIO G Direction Control Register |
| Reserved | 0x00 70DA | 1 | |
| Reserved | 0x00 70DB | 1 | |
| Reserved | 0x00 70DC – 0x00 70DF | 4 | |

(1) Reserved locations return undefined values and writes are ignored.

(2) Not all inputs support input signal qualification.

(3) These registers are EALLOW protected. This prevents spurious writes from overwriting the contents and corrupting the system.

If configured for "Digital I/O" mode, additional registers are provided for setting individual I/O signals (via the GPxSET registers), for clearing individual I/O signals (via the GPxCLEAR registers), for toggling individual I/O signals (via the GPxTOGGLE registers), or for reading/writing to the individual I/O signals (via the GPxDAT registers). [Table 4-12](#) lists the GPIO Data Registers. For more information, see the *TMS320x281x DSP System Control and Interrupts Reference Guide* (literature number [SPRU078](#)).

Table 4-12. GPIO Data Registers⁽¹⁾⁽²⁾

| NAME | ADDRESS | SIZE (x16) | DESCRIPTION |
|-----------|-----------------------|------------|------------------------|
| GPADAT | 0x00 70E0 | 1 | GPIO A Data Register |
| GPASET | 0x00 70E1 | 1 | GPIO A Set Register |
| GPACLEAR | 0x00 70E2 | 1 | GPIO A Clear Register |
| GPATOGGLE | 0x00 70E3 | 1 | GPIO A Toggle Register |
| GPBDAT | 0x00 70E4 | 1 | GPIO B Data Register |
| GPBSET | 0x00 70E5 | 1 | GPIO B Set Register |
| GPBCLEAR | 0x00 70E6 | 1 | GPIO B Clear Register |
| GPBTOGGLE | 0x00 70E7 | 1 | GPIO B Toggle Register |
| Reserved | 0x00 70E8 | 1 | |
| Reserved | 0x00 70E9 | 1 | |
| Reserved | 0x00 70EA | 1 | |
| Reserved | 0x00 70EB | 1 | |
| GPDDAT | 0x00 70EC | 1 | GPIO D Data Register |
| GPDSET | 0x00 70ED | 1 | GPIO D Set Register |
| GPDCLEAR | 0x00 70EE | 1 | GPIO D Clear Register |
| GPDTOGGLE | 0x00 70EF | 1 | GPIO D Toggle Register |
| GPEDAT | 0x00 70F0 | 1 | GPIO E Data Register |
| GPESET | 0x00 70F1 | 1 | GPIO E Set Register |
| GPECLEAR | 0x00 70F2 | 1 | GPIO E Clear Register |
| GPETOGGLE | 0x00 70F3 | 1 | GPIO E Toggle Register |
| GPFDAT | 0x00 70F4 | 1 | GPIO F Data Register |
| GPFSET | 0x00 70F5 | 1 | GPIO F Set Register |
| GPFCLEAR | 0x00 70F6 | 1 | GPIO F Clear Register |
| GPFTOGGLE | 0x00 70F7 | 1 | GPIO F Toggle Register |
| GPGDAT | 0x00 70F8 | 1 | GPIO G Data Register |
| GPGSET | 0x00 70F9 | 1 | GPIO G Set Register |
| GPGCLEAR | 0x00 70FA | 1 | GPIO G Clear Register |
| GPGTOGGLE | 0x00 70FB | 1 | GPIO G Toggle Register |
| Reserved | 0x00 70FC – 0x00 70FF | 4 | |

(1) Reserved locations will return undefined values and writes will be ignored.

(2) These registers are NOT EALLOW protected. The above registers will typically be accessed regularly by the user.

Figure 4-12 shows how the various register bits select the various modes of operation for GPIO function.

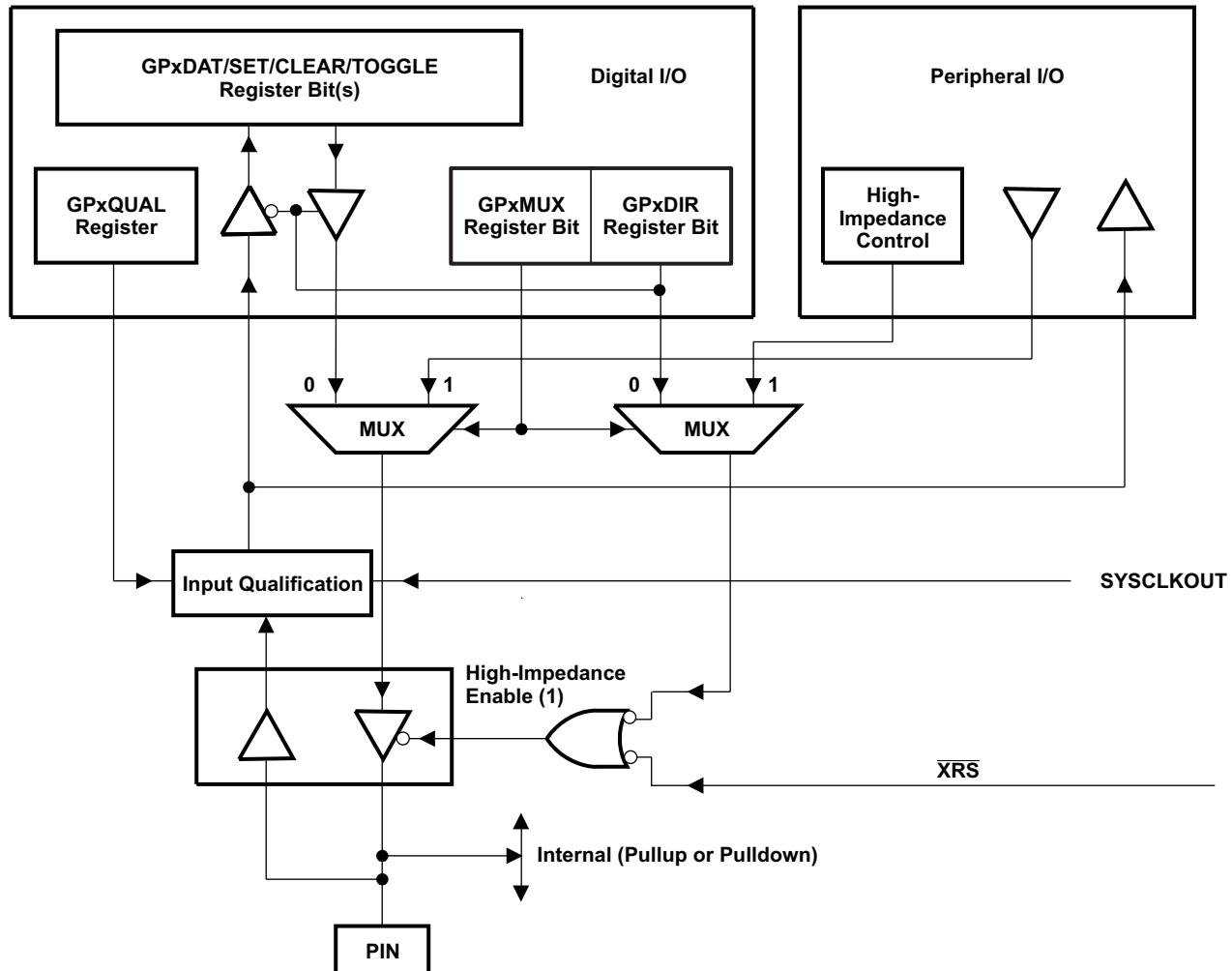

- A. In the GPIO mode, when the GPIO pin is configured for output operation, reading the GPxDAT data register only gives the value written, not the value at the pin. In the peripheral mode, the state of the pin can be read through the GPxDAT register, provided the corresponding direction bit is zero (input mode).
- B. Some selected input signals are qualified by the SYSCLKOUT. The GPxQUAL register specifies the qualification sampling period. The sampling window is 6 samples wide and the output is only changed when all samples are the same (all 0's or all 1's). This feature removes unwanted spikes from the input signal.

Figure 4-12. GPIO/Peripheral Pin Multiplexing

NOTE

The input function of the GPIO pin and the input path to the peripheral are always enabled. It is the output function of the GPIO pin that is multiplexed with the output path of the primary (peripheral) function. Since the output buffer of a pin connects back to the input buffer, any GPIO signal present at the pin will be propagated to the peripheral module as well. Therefore, when a pin is configured for GPIO operation, the corresponding peripheral functionality (and interrupt-generating capability) must be disabled. Otherwise, interrupts may be inadvertently triggered. This is especially critical when the PDPINTA and PDPINTB pins are used as GPIO pins, since a value of zero for GPDDAT.0 or GPDDAT.5 (PDPINTx) will put PWM pins in a high-impedance state. The CxTRIP and TxTRIP pins will also put the corresponding PWM pins in high impedance, if they are driven low (as GPIO pins) and bit EXTCONx.0 = 1.

5 Development Support

Texas Instruments (TI™) offers an extensive line of development tools for the C28x™ generation of DSPs, including tools to evaluate the performance of the processors, generate code, develop algorithm implementations, and fully integrate and debug software and hardware modules.

The following products support development of F281x- and C281x-based applications:

Software Development Tools

- Code Composer Studio™ Integrated Development Environment (IDE)
 - C/C++ Compiler
 - Code generation tools
 - Assembler/Linker
 - Cycle Accurate Simulator
- Application algorithms
- Sample applications code

Hardware Development Tools

- 2812 eZdsp
- JTAG-based emulators – SPI515, XDS510PP, XDS510PP Plus, XDS510 USB
- Universal 5-V dc power supply
- Documentation and cables

5.1 Device and Development Support Tool Nomenclature

To designate the stages in the product development cycle, TI assigns prefixes to the part numbers of all TMS320™ DSP devices and support tools. Each TMS320 DSP commercial family member has one of three prefixes: TMX, TMP, or TMS (for example, **TMS320F2812GHH**). Texas Instruments recommends two of three possible prefix designators for its support tools: TMDX and TMDS. These prefixes represent evolutionary stages of product development from engineering prototypes (TMX/TMDX) through fully qualified production devices/tools (TMS/TMDS).

| | |
|------------|--|
| TMX | Experimental device that is not necessarily representative of the final device's electrical specifications |
| TMP | Final silicon die that conforms to the device's electrical specifications but has not completed quality and reliability verification |
| TMS | Fully qualified production device |

Support tool development evolutionary flow:

| | |
|-------------|---|
| TMDX | Development-support product that has not yet completed Texas Instruments internal qualification testing |
| TMDS | Fully qualified development-support product |

TMX and TMP devices and TMDX development-support tools are shipped against the following disclaimer:

"Developmental product is intended for internal evaluation purposes."

TMS devices and TMDS development-support tools have been characterized fully, and the quality and reliability of the device have been demonstrated fully. TI's standard warranty applies.

Predictions show that prototype devices (TMX or TMP) have a greater failure rate than the standard production devices. Texas Instruments recommends that these devices not be used in any production system because their expected end-use failure rate still is undefined. Only qualified production devices are to be used.

TI device nomenclature also includes a suffix with the device family name. This suffix indicates the package type (for example, PBK) and temperature range (for example, A). [Figure 5-1](#) provides a legend for reading the complete device name for any TMS320x281x family member.

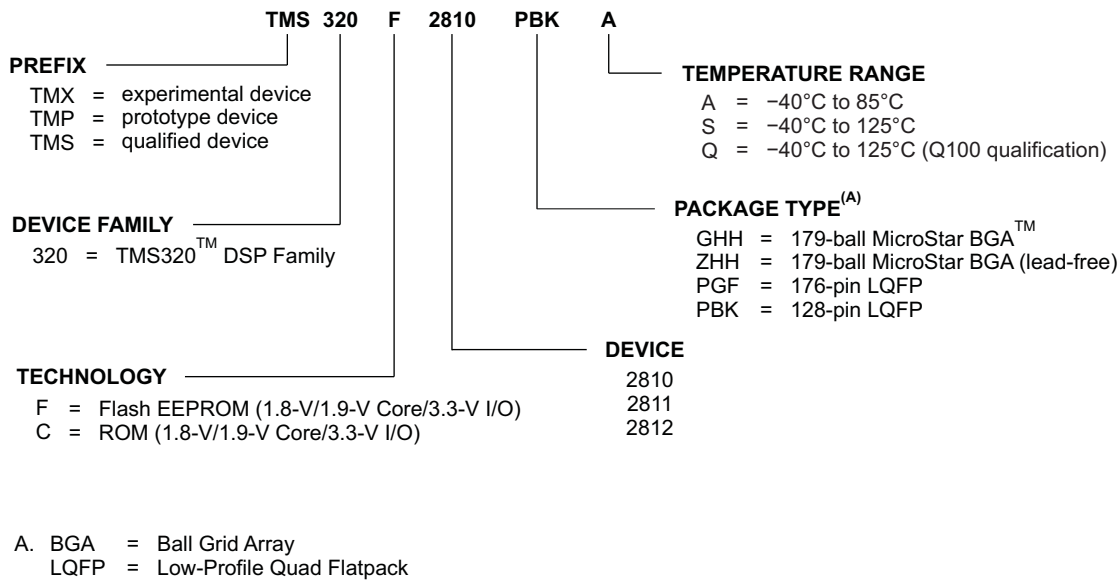

Figure 5-1. TMS320x281x Device Nomenclature

5.2 Documentation Support

Extensive documentation supports all of the TMS320™ DSP family generations of devices from product announcement through applications development. The types of documentation available include: data sheets and data manuals, with design specifications; and hardware and software applications.

[Table 5-1](#) shows the peripheral reference guides appropriate for use with the devices in this data manual. See the *TMS320x28xx, 28xxx DSP Peripheral Reference Guide* (literature number [SPRU566](#)) for more information on types of peripherals.

Table 5-1. TMS320x281x Peripheral Selection Guide

| PERIPHERAL | LIT. NO. | TYPE ⁽¹⁾ | 2812 | 2811, 2810 |
|---|-------------------------|---------------------|------|---------------|
| TMS320x281x DSP System Control and Interrupts | SPRU078 | – | x | x |
| TMS320x281x DSP External Interface (XINTF) | SPRU067 | 0 | x | |
| TMS320x281x Enhanced Controller Area Network (eCAN) | SPRU074 | 0 | x | x |
| TMS320x281x DSP Event Manager (EV) | SPRU065 | 0 | x | x |
| TMS320x281x DSP Analog-to-Digital Converter (ADC) | SPRU060 | 0 | x | x |
| TMS320x281x DSP Multichannel Buffered Serial Port (McBSP) | SPRU061 | 0 | x | x |
| TMS320x281x Serial Communications Interface (SCI) | SPRU051 | 0 | x | x |
| TMS320x281x Serial Peripheral Interface | SPRU059 | 0 | x | x |
| TMS320x281x DSP Boot ROM | SPRU095 | – | x | x |

(1) A type change represents a major functional feature difference in a peripheral module. Within a peripheral type, there may be minor differences between devices which do not affect the basic functionality of the module. These device-specific differences are listed in the peripheral reference guides.

The following documents are available on the TI website (<http://www.ti.com>):

- [SPRU430](#) **TMS320C28x CPU and Instruction Set Reference Guide** describes the central processing unit (CPU) and the assembly language instructions of the TMS320C28x™ fixed-point digital signal processors (DSPs). It also describes emulation features available on these DSPs.
- [SPRU060](#) **TMS320x281x DSP Analog-to-Digital Converter (ADC) Reference Guide** describes the ADC module. The module is a 12-bit pipelined ADC. The analog circuits of this converter, referred to as the core in this document, include the front-end analog multiplexers (MUXs), sample-and-hold (S/H) circuits, the conversion core, voltage regulators, and other analog supporting circuits. Digital circuits, referred to as the wrapper in this document, include programmable conversion sequencer, result registers, interface to analog circuits, interface to device peripheral bus, and interface to other on-chip modules.
- [SPRU095](#) **TMS320x281x DSP Boot ROM Reference Guide** describes the purpose and features of the bootloader (factory-programmed boot-loading software). It also describes other contents of the device on-chip boot ROM and identifies where all of the information is located within that memory.
- [SPRU065](#) **TMS320x281x DSP Event Manager (EV) Reference Guide** describes the EV modules that provide a broad range of functions and features that are particularly useful in motion control and motor control applications. The EV modules include general-purpose (GP) timers, full-compare/PWM units, capture units, and quadrature-encoder pulse (QEP) circuits.
- [SPRU067](#) **TMS320x281x DSP External Interface (XINTF) Reference Guide** describes the external interface (XINTF) of the 281x digital signal processors (DSPs).
- [SPRU061](#) **TMS320x281x DSP Multichannel Buffered Serial Port (McBSP) Reference Guide** describes the McBSP available on the 281x devices. The McBSPs allow direct interface between a DSP and other devices in a system.
- [SPRU078](#) **TMS320x281x DSP System Control and Interrupts Reference Guide** describes the various interrupts and system control features of the 281x digital signal processors (DSPs).
- [SPRU074](#) **TMS320x281x Enhanced Controller Area Network (eCAN) Reference Guide** describes the eCAN that uses established protocol to communicate serially with other controllers in electrically noisy environments. With 32 fully configurable mailboxes and time-stamping feature, the eCAN module provides a versatile and robust serial communication interface. The eCAN module implemented in the C28x DSP is compatible with the CAN 2.0B standard (active).
- [SPRU566](#) **TMS320x28xx, 28xxx DSP Peripheral Reference Guide** describes the peripheral reference guides of the 28x digital signal processors (DSPs).
- [SPRU051](#) **TMS320x281x Serial Communications Interface (SCI) Reference Guide** describes the SCI that is a two-wire asynchronous serial port, commonly known as a UART. The SCI modules support digital communications between the CPU and other asynchronous peripherals that use the standard non-return-to-zero (NRZ) format.
- [SPRU059](#) **TMS320x281x Serial Peripheral Interface Reference Guide** describes the SPI—a high-speed synchronous serial input/output (I/O) port that allows a serial bit stream of programmed length (one to sixteen bits) to be shifted into and out of the device at a programmed bit-transfer rate. The SPI is used for communications between the DSP controller and external peripherals or another controller.

- [SPRA550](#) **3.3V DSP for Digital Motor Control Application Report.** The application report first describes a scenario of a 3.3-V-only motor controller indicating that for most applications, no significant issue of interfacing between 3.3 V and 5 V exists. Cost-effective 3.3-V/5-V interfacing techniques are then discussed for the situations where such interfacing is needed. On-chip 3.3-V analog-to-digital converter (ADC) versus 5-V ADC is also discussed. Guidelines for component layout and printed circuit board (PCB) design that can reduce system noise and EMI effects are summarized in the last section.
- [SPRU608](#) **TMS320C28x Instruction Set Simulator Technical Overview** describes the simulator, available within the Code Composer Studio for TMS320C2000™ IDE, that simulates the instruction set of the C28x core.
- [SPRU625](#) **TMS320C28x DSP/BIOS 5.x Application Programming Interface (API) Reference Guide** describes development using DSP/BIOS™.
- [SPRU513](#) **TMS320C28x Assembly Language Tools v5.0 User's Guide** describes the assembly language tools (assembler and other tools used to develop assembly language code), assembler directives, macros, common object file format, and symbolic debugging directives for the TMS320C28x™ device.
- [SPRU514](#) **TMS320C28x Optimizing C/C++ Compiler v5.0 User's Guide** describes the TMS320C28x™ C/C++ compiler. This compiler accepts ANSI standard C/C++ source code and produces TMS320™ DSP assembly language source code for the TMS320C28x device.
- [SPRA876](#) **Programming Examples for the TMS320F281x eCAN Application Report** contains several programming examples to illustrate how the eCAN module is set up for different modes of operation. The objective is to help you come up to speed quickly in programming the eCAN. All programs have been extensively commented to aid easy understanding. The CANalyzer tool from Vector CANtech, Inc. was used to monitor and control the bus operation. All projects and CANalyzer configuration files are included in the [spra876.zip](#) file.
- [SPRA989](#) **F2810, F2811, and F2812 ADC Calibration Application Report** describes a method for improving the absolute accuracy of the 12-bit analog-to-digital converter (ADC) found on the F2810/F2811/F2812 devices. Due to inherent gain and offset errors, the absolute accuracy of the ADC is impacted. The methods described in this application note can improve the absolute accuracy of the ADC to achieve levels better than 0.5%. This application note is accompanied by an example program (ADCcalibration, [spra989.zip](#)) that executes from RAM on the F2812 eZdsp.

A series of DSP textbooks is published by Prentice-Hall and John Wiley & Sons to support digital signal processing research and education. The TMS320™ DSP newsletter, *Details on Signal Processing*, is published quarterly and distributed to update TMS320™ DSP customers on product information.

Updated information on the TMS320™ DSP controllers can be found on the worldwide web at: <http://www.ti.com>.

To send comments regarding this *TMS320F2810, TMS320F2811, TMS320F2812, TMS320C2810, TMS320C2811, TMS320C2812 Digital Signal Processors Data Manual* (literature number [SPRS174](#)), click on the *Submit Documentation Feedback* link at the bottom of the page. For questions and support, contact the Product Information Center listed at the <http://www.ti.com/sc/docs/pic/home.htm> site.

5.3 Community Resources

The following links connect to TI community resources. Linked contents are provided "AS IS" by the respective contributors. They do not constitute TI specifications and do not necessarily reflect TI's views; see TI's [Terms of Use](#).

[TI E2E Community](#) *TI's Engineer-to-Engineer (E2E) Community.* Created to foster collaboration among engineers. At e2e.ti.com, you can ask questions, share knowledge, explore ideas and help solve problems with fellow engineers.

[TI Embedded Processors Wiki](#) *Texas Instruments Embedded Processors Wiki*. Established to help developers get started with Embedded Processors from Texas Instruments and to foster innovation and growth of general knowledge about the hardware and software surrounding these devices.

6 Electrical Specifications

This section provides the absolute maximum ratings and the recommended operating conditions for the TMS320F281x and TMS320C281x DSPs.

6.1 Absolute Maximum Ratings⁽¹⁾

| | | | |
|--|---|--|-----------------|
| Supply voltage range (V_{DDIO} , V_{DD3VFL} , V_{DDA1} , V_{DDA2} , V_{DDAIO} , and $AVDDREFBG$) | | | –0.3 V to 4.6 V |
| Supply voltage range (V_{DD} , V_{DD1}) | | | –0.5 V to 2.5 V |
| Input voltage range, V_{IN} | | | –0.3 V to 4.6 V |
| Output voltage range, V_O | | | –0.3 V to 4.6 V |
| Input clamp current, I_{IK} ($V_{IN} < 0$ or $V_{IN} > V_{DDIO}$) ⁽²⁾ | | | ±20 mA |
| Output clamp current, I_{OK} ($V_O < 0$ or $V_O > V_{DDIO}$) | | | ±20 mA |
| Operating ambient temperature ranges, T_A | A version (GHH, ZHH, PGF, PBK) ⁽³⁾ | | –40°C to 85°C |
| | S version (GHH, ZHH, PGF, PBK) ⁽³⁾ | | –40°C to 125°C |
| | Q version (PGF, PBK) ⁽³⁾ | | –40°C to 125°C |
| Junction temperature range, T_J | | | –40°C to 150°C |
| Storage temperature range, T_{stg} ⁽³⁾ | | | –65°C to 150°C |

- (1) Unless otherwise noted, the list of absolute maximum ratings are specified over operating temperature ranges. Stresses beyond those listed under Absolute Maximum Ratings may cause permanent damage to the device. These are stress ratings only, and functional operation of the device at these or any other conditions beyond those indicated under [Section 6.2](#), Recommended Operating Conditions, is not implied. Exposure to absolute-maximum-rated conditions for extended periods may affect device reliability. All voltage values are with respect to V_{SS} .
- (2) Continuous clamp current per pin is ±2 mA
- (3) Long-term high-temperature storage and/or extended use at maximum temperature conditions may result in a reduction of overall device life. For additional information, see the *IC Package Thermal Metrics Application Report* (literature number [SPRA953](#)) and the *Reliability Data for TMS320LF24xx and TMS320F28xx Devices Application Report* (literature number [SPRA963](#)).

6.2 Recommended Operating Conditions⁽¹⁾

| | | | MIN | NOM | MAX | UNIT |
|---|--|------------------------------------|-------------|-----|-------------|------|
| V_{DDIO} | Device supply voltage, I/O | | 3.14 | 3.3 | 3.47 | V |
| V_{DD} , V_{DD1} | Device supply voltage, CPU | 1.8 V (135 MHz) | 1.71 | 1.8 | 1.89 | V |
| | | 1.9 V (150 MHz) | 1.81 | 1.9 | 2 | |
| V_{SS} | Supply ground | | | 0 | | V |
| V_{DDA1} , V_{DDA2} , $AVDDREFBG$, V_{DDAIO} | ADC supply voltage | | 3.14 | 3.3 | 3.47 | V |
| V_{DD3VFL} | Flash programming supply voltage | | 3.14 | 3.3 | 3.47 | V |
| $f_{SYSCLKOUT}$ | Device clock frequency (system clock) | $V_{DD} = 1.9 \text{ V} \pm 5\%$ | 2 | | 150 | MHz |
| | | $V_{DD} = 1.8 \text{ V} \pm 5\%$ | 2 | | 135 | |
| V_{IH} | High-level input voltage | All inputs except X1/XCLKIN | 2 | | V_{DDIO} | V |
| | | X1/XCLKIN (@ 50 μA max) | $0.7V_{DD}$ | | V_{DD} | |
| V_{IL} | Low-level input voltage | All inputs except X1/XCLKIN | | | 0.8 | V |
| | | X1/XCLKIN (@ 50 μA max) | | | $0.3V_{DD}$ | |
| I_{OH} | High-level output source current, $V_{OH} = 2.4 \text{ V}$ | All I/Os except Group 2 | | | –4 | mA |
| | | Group 2 ⁽²⁾ | | | –8 | |
| I_{OL} | Low-level output sink current, $V_{OL} = V_{OL \text{ MAX}}$ | All I/Os except Group 2 | | | 4 | mA |
| | | Group 2 ⁽²⁾ | | | 8 | |
| T_A | Ambient temperature | A version | –40 | | 85 | °C |
| | | S version | –40 | | 125 | |
| | | Q version | –40 | | 125 | |

- (1) See [Section 6.8](#) for power sequencing of V_{DDIO} , V_{DDAIO} , V_{DD} , $V_{DDA1}/V_{DDA2}/AVDDREFBG$, and V_{DD3VFL} .
- (2) Group 2 pins are as follows: XINTF pins, T1CTRIP_PDPINTA, TDO, XCLKOUT, XF, EMU0, and EMU1.

6.3 Electrical Characteristics Over Recommended Operating Conditions (Unless Otherwise Noted)

| PARAMETER | | TEST CONDITIONS | | MIN | TYP | MAX | UNIT |
|--------------------------------|---|---|--|--|------|------|------|
| V _{OH} | High-level output voltage | I _{OH} = I _{OH} MAX | | 2.4 | | | V |
| | | I _{OH} = 50 μA | | V _{DDIO} – 0.2 | | | |
| V _{OL} | Low-level output voltage | I _{OL} = I _{OL} MAX | | 0.4 | | | V |
| I _{IL} ⁽¹⁾ | Input current (low level) | With pullup | V _{DDIO} = 3.3 V, V _{IN} = 0 V | –80 | –140 | –190 | μA |
| | | With pulldown | V _{DDIO} = 3.3 V, V _{IN} = 0 V | ±2 | | | |
| I _{IL} ⁽²⁾ | Input current (low level) | With pullup | V _{DDIO} = 3.3 V, V _{IN} = 0 V | All I/Os ⁽³⁾ (including XRS) except EVB | | | μA |
| | | | | GPIOB/EVB | | | |
| | | With pulldown | V _{DDIO} = 3.3 V, V _{IN} = 0 V | ±2 | | | |
| I _{IH} | Input current (high level) | With pullup | V _{DDIO} = 3.3 V, V _{IN} = V _{DD} | ±2 | | | μA |
| | | With pulldown ⁽⁴⁾ | V _{DDIO} = 3.3 V, V _{IN} = V _{DD} | 28 | 50 | 80 | |
| I _{OZ} | Leakage current (for pins without internal PU/PD), high-impedance state (off-state) | V _O = V _{DDIO} or 0 V | | ±2 | | | μA |
| C _i | Input capacitance | | | 2 | | | pF |
| C _o | Output capacitance | | | 3 | | | pF |

(1) Applicable to C281x devices

(2) Applicable to F281x devices

(3) The following pins have no internal PU/PD: GPIOE0, GPIOE1, GPIOF0, GPIOF1, GPIOF2, GPIOF3, GPIOF12, GPIOG4, and GPIOG5.

(4) The following pins have an internal pulldown: XMP/MC, TESTSEL, and TRST.

6.4 Current Consumption

Table 6-1. TMS320F281x Current Consumption by Power-Supply Pins Over Recommended Operating Conditions During Low-Power Modes at 150-MHz SYSCLKOUT

| MODE | TEST CONDITIONS | I _{DD} | | I _{DDIO} ⁽¹⁾ | | I _{DD3VFL} | | I _{DDA} ⁽²⁾ | |
|-------------|---|-----------------------|--------------------|----------------------------------|--------------------|---------------------|--------------------|---------------------------------|--------------------|
| | | TYP | MAX ⁽³⁾ | TYP | MAX ⁽³⁾ | TYP | MAX ⁽³⁾ | TYP | MAX ⁽³⁾ |
| Operational | All peripheral clocks are enabled. All PWM pins are toggled at 100 kHz. Data is continuously transmitted out of the SCIA, SCIB, and CAN ports. The hardware multiplier is exercised. Code is running out of flash with 5 wait-states. | 195 mA ⁽⁴⁾ | 230 mA | 15 mA | 30 mA | 40 mA | 45 mA | 40 mA | 50 mA |
| IDLE | <ul style="list-style-type: none"> Flash is powered down XCLKOUT is turned off All peripheral clocks are on, except ADC | 125 mA | 150 mA | 5 mA | 10 mA | 2 μA | 4 μA | 1 μA | 20 μA |
| STANDBY | <ul style="list-style-type: none"> Flash is powered down Peripheral clocks are turned off Pins without an internal PU/PD are tied high/low | 5 mA | 10 mA | 5 μA | 20 μA | 2 μA | 4 μA | 1 μA | 20 μA |
| HALT | <ul style="list-style-type: none"> Flash is powered down Peripheral clocks are turned off Pins without an internal PU/PD are tied high/low Input clock is disabled | 70 μA | | 5 μA | 20 μA | 2 μA | 4 μA | 1 μA | 20 μA |

(1) I_{DDIO} current is dependent on the electrical loading on the I/O pins.

(2) I_{DDA} includes current into V_{DDA1}, V_{DDA2}, AVDDREFBG, and V_{DDAIO} pins.

(3) MAX numbers are at 125°C, and MAX voltage (V_{DD} = 1.89 V; V_{DDIO}, V_{DD3VFL}, V_{DDA} = 3.47 V).

(4) I_{DD} represents the total current drawn from the 1.8-V rail (V_{DD}). It includes a small amount of current (<1 mA) drawn by V_{DD1}.

NOTE

HALT and STANDBY modes cannot be used when the PLL is disabled.

Table 6-2. TMS320C281x Current Consumption by Power-Supply Pins Over Recommended Operating Conditions During Low-Power Modes at 150-MHz SYSCLKOUT

| MODE | TEST CONDITIONS | I _{DD} | | I _{DDIO} ⁽¹⁾ | | I _{DDA} ⁽²⁾ | |
|-------------|---|-----------------------|--------------------|----------------------------------|--------------------|---------------------------------|--------------------|
| | | TYP | MAX ⁽³⁾ | TYP | MAX ⁽³⁾ | TYP | MAX ⁽³⁾ |
| Operational | All peripheral clocks are enabled. All PWM pins are toggled at 100 kHz. Data is continuously transmitted out of the SCIA, SCIB, and CAN ports. The hardware multiplier is exercised. Code is running out of ROM with 5 wait-states. | 210 mA ⁽⁴⁾ | 260 mA | 20 mA | 30 mA | 40 mA | 50 mA |
| IDLE | <ul style="list-style-type: none"> XCLKOUT is turned off All peripheral clocks are on, except ADC | 140 mA | 165 mA | 20 mA | 30 mA | 5 μA | 10 μA |
| STANDBY | <ul style="list-style-type: none"> Peripheral clocks are turned off Pins without an internal PU/PD are tied high/low | 5 mA | 10 mA | 5 μA | 20 μA | 5 μA | 10 μA |
| HALT | <ul style="list-style-type: none"> Peripheral clocks are turned off Pins without an internal PU/PD are tied high/low Input clock is disabled | 70 μA | | 5 μA | 10 μA | 1 μA | |

- (1) I_{DDIO} current is dependent on the electrical loading on the I/O pins.
(2) I_{DDA} includes current into V_{DDA1}, V_{DDA2}, AVDDREFBG, and V_{DDAIO} pins.
(3) MAX numbers are at 125°C, and MAX voltage (V_{DD} = 1.89 V; V_{DDIO}, V_{DD3VFL}, V_{DDA} = 3.47 V).
(4) I_{DD} represents the total current drawn from the 1.8-V rail (V_{DD}). It includes a small amount of current (<1 mA) drawn by V_{DD1}.

6.5 Current Consumption Graphs

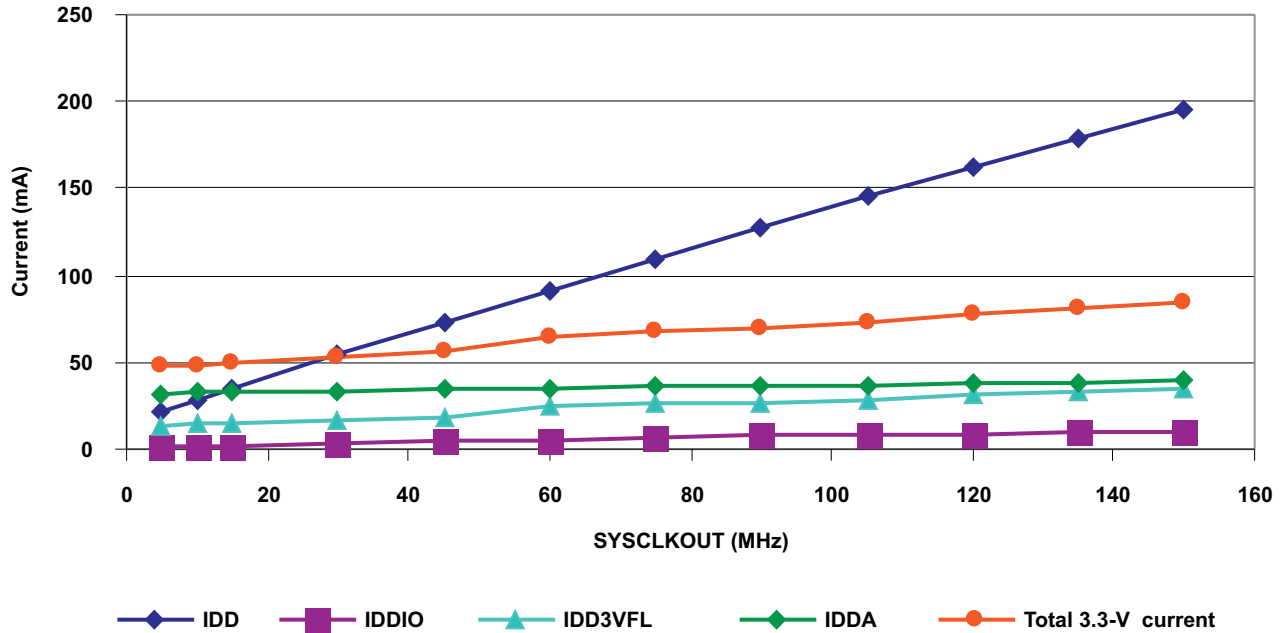

- Test conditions are as defined in Table 6-1 for operational currents.
- I_{DD} represents the total current drawn from the 1.8-V rail (V_{DD}). It includes a small amount of current (<1 mA) drawn by V_{DD1} .
- I_{DDA} represents the current drawn by V_{DDA1} and V_{DDA2} rails.
- Total 3.3-V current is the sum of I_{DDIO} , I_{DD3VFL} , and I_{DDA} . It includes a small amount of current (<1 mA) drawn by V_{DDAIO} .

Figure 6-1. F2812/F2811/F2810 Typical Current Consumption Over Frequency

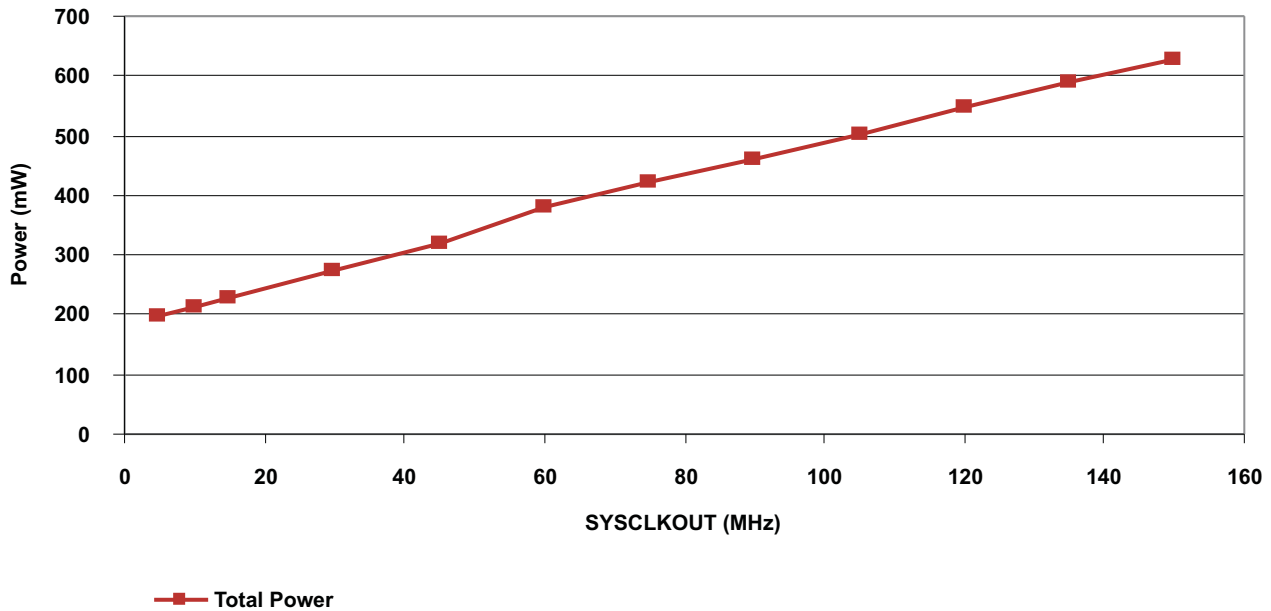
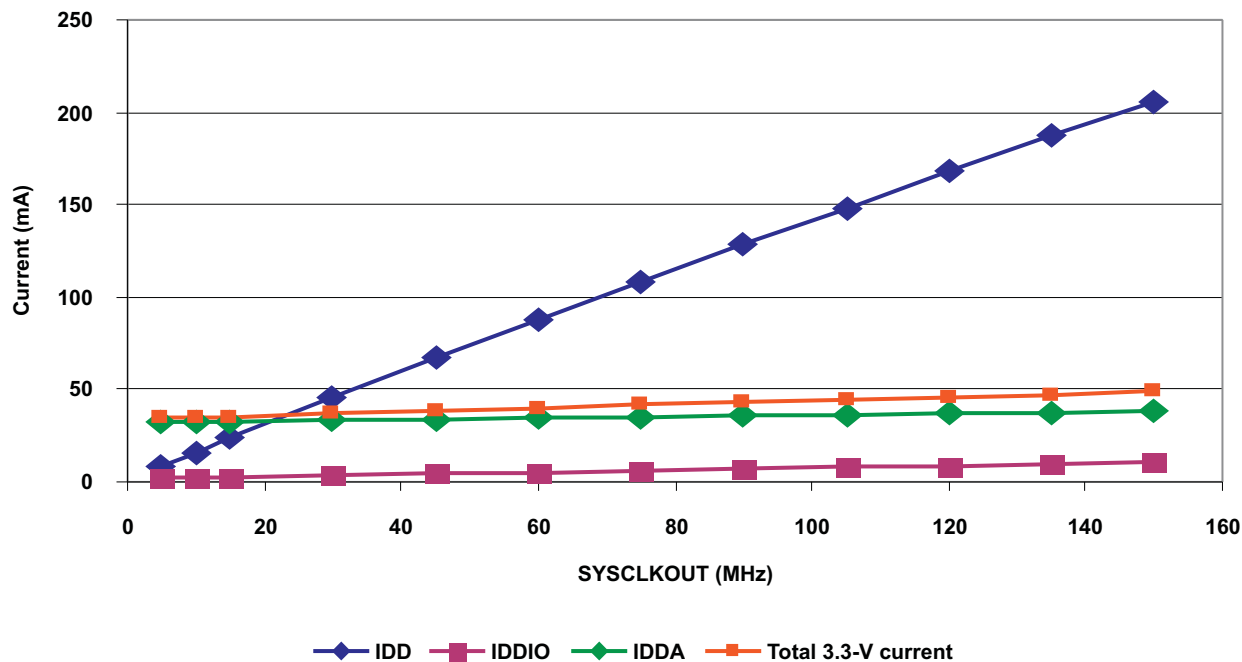

Figure 6-2. F2812/F2811/F2810 Typical Power Consumption Over Frequency



- A. Test conditions are as defined in Table 6-2 for operational currents.
- B. I_{DD} represents the total current drawn from the 1.8-V rail (V_{DD}). It includes a small amount of current (<1 mA) drawn by V_{DD1} .
- C. I_{DDA} represents the current drawn by V_{DDA1} and V_{DDA2} rails.
- D. Total 3.3-V current is the sum of I_{DDIO} and I_{DDA} . It includes a small amount of current (<1 mA) drawn by V_{DDAIO} .

Figure 6-3. C2812/C2811/C2810 Typical Current Consumption Over Frequency

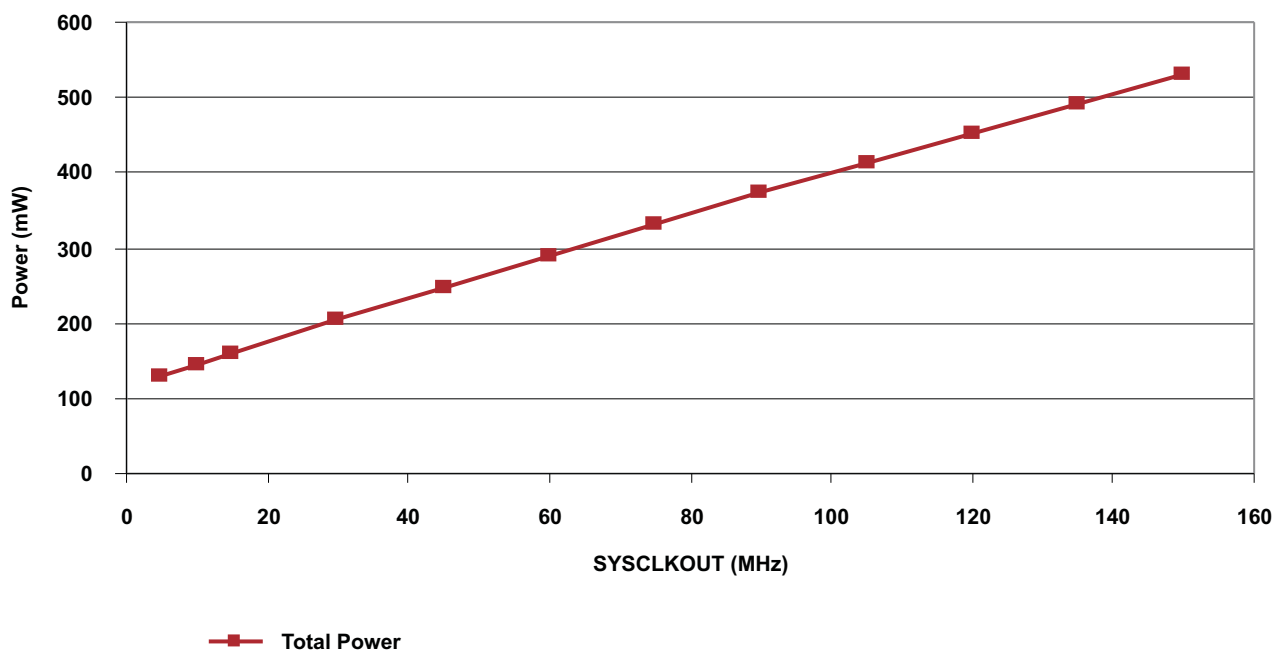

Figure 6-4. C2812/C2811/C2810 Typical Power Consumption Over Frequency

6.6 Reducing Current Consumption

28x DSPs incorporate a unique method to reduce the device current consumption. A reduction in current consumption can be achieved by turning off the clock to any peripheral module which is not used in a given application. Table 6-3 indicates the typical reduction in current consumption achieved by turning off the clocks to various peripherals.

Table 6-3. Typical Current Consumption by Various Peripherals (at 150 MHz)⁽¹⁾

| PERIPHERAL MODULE | I _{DD} CURRENT REDUCTION (mA) |
|-------------------|--|
| eCAN | 12 |
| EVA | 6 |
| EVB | 6 |
| ADC | 8 ⁽²⁾ |
| SCI | 4 |
| SPI | 5 |
| McBSP | 13 |

- (1) All peripheral clocks are disabled upon reset. Writing to/reading from peripheral registers is possible only after the peripheral clocks are turned on.
- (2) This number represents the current drawn by the digital portion of the ADC module. Turning off the clock to the ADC module results in the elimination of the current drawn by the analog portion of the ADC (I_{DDA}) as well.

6.7 Emulator Connection Without Signal Buffering for the DSP

Figure 6-5 shows the connection between the DSP and JTAG header for a single-processor configuration. If the distance between the JTAG header and the DSP is greater than 6 inches, the emulation signals must be buffered. If the distance is less than 6 inches, buffering is typically not needed. Figure 6-5 shows the simpler, no-buffering situation. For the pullup/pulldown resistor values, see the pin description section.

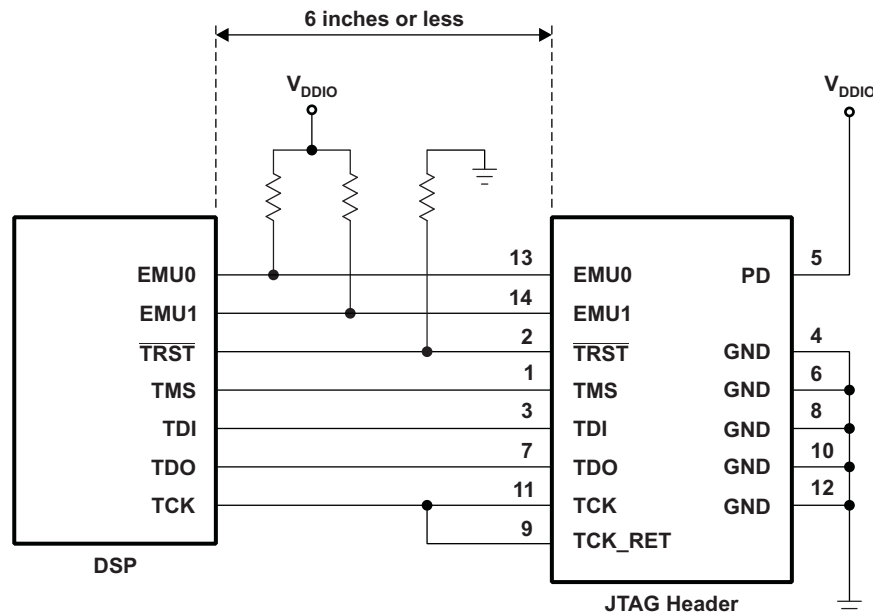

Figure 6-5. Emulator Connection Without Signal Buffering for the DSP

6.8 Power Sequencing Requirements

TMS320F2812/F2811/F2810 silicon requires dual voltages (1.8-V or 1.9-V and 3.3-V) to power up the CPU, Flash, ROM, ADC, and the I/Os. To ensure the correct reset state for all modules during power up, there are some requirements to be met while powering up/powering down the device. The current F2812 silicon reference schematics (Spectrum Digital Incorporated eZdsp board) suggests two options for the power sequencing circuit.

Power sequencing is not needed for C281x devices. In other words, 3.3-V and 1.8-V (or 1.9-V) can ramp together. C281x can also be used on boards that have F281x power sequencing implemented; however, if the 1.8-V (or 1.9-V) rail lags the 3.3-V rail, the GPIO pins are undefined until the 1.8-V rail reaches at least 1 V.

- Option 1:
In this approach, an external power sequencing circuit enables V_{DDIO} first, then V_{DD} and V_{DD1} (1.8 V or 1.9 V). After 1.8 V (or 1.9 V) ramps, the 3.3 V for Flash (V_{DD3VFL}) and ADC ($V_{DDA1}/V_{DDA2}/AVDDREFBG$) modules are ramped up. While option 1 is still valid, TI has simplified the requirement. Option 2 is the recommended approach.
- Option 2:
Enable power to all 3.3-V supply pins (V_{DDIO} , V_{DD3VFL} , $V_{DDA1}/V_{DDA2}/V_{DDAIO}/AVDDREFBG$) and then ramp 1.8 V (or 1.9 V) (V_{DD}/V_{DD1}) supply pins.
1.8 V or 1.9 V (V_{DD}/V_{DD1}) should not reach 0.3 V until V_{DDIO} has reached 2.5 V. This ensures the reset signal from the I/O pin has propagated through the I/O buffer to provide power-on reset to all the modules inside the device. See [Figure 6-11](#) for power-on reset timing.
- Power-Down Sequencing:
During power-down, the device reset should be asserted low (8 μ s, minimum) before the V_{DD} supply reaches 1.5 V. This will help to keep on-chip flash logic in reset prior to the V_{DDIO}/V_{DD} power supplies ramping down. It is recommended that the device reset control from “Low-Dropout (LDO)” regulators or voltage supervisors be used to meet this constraint. LDO regulators that facilitate power-sequencing (with the aid of additional external components) may be used to meet the power sequencing requirement. See www.spectrumdigital.com for F2812 eZdsp™ schematics and updates.

Table 6-4. Recommended “Low-Dropout Regulators”

| SUPPLIER | PART NUMBER | DESCRIPTION |
|-------------------|-------------|---|
| Texas Instruments | TPS75005 | Dual 500-mA low-dropout regulator (LDO) with sequencing for C2000 (3 Voltage Rail Monitors) |

NOTE

The GPIO pins are undefined until $V_{DD} = 1$ V and $V_{DDIO} = 2.5$ V.

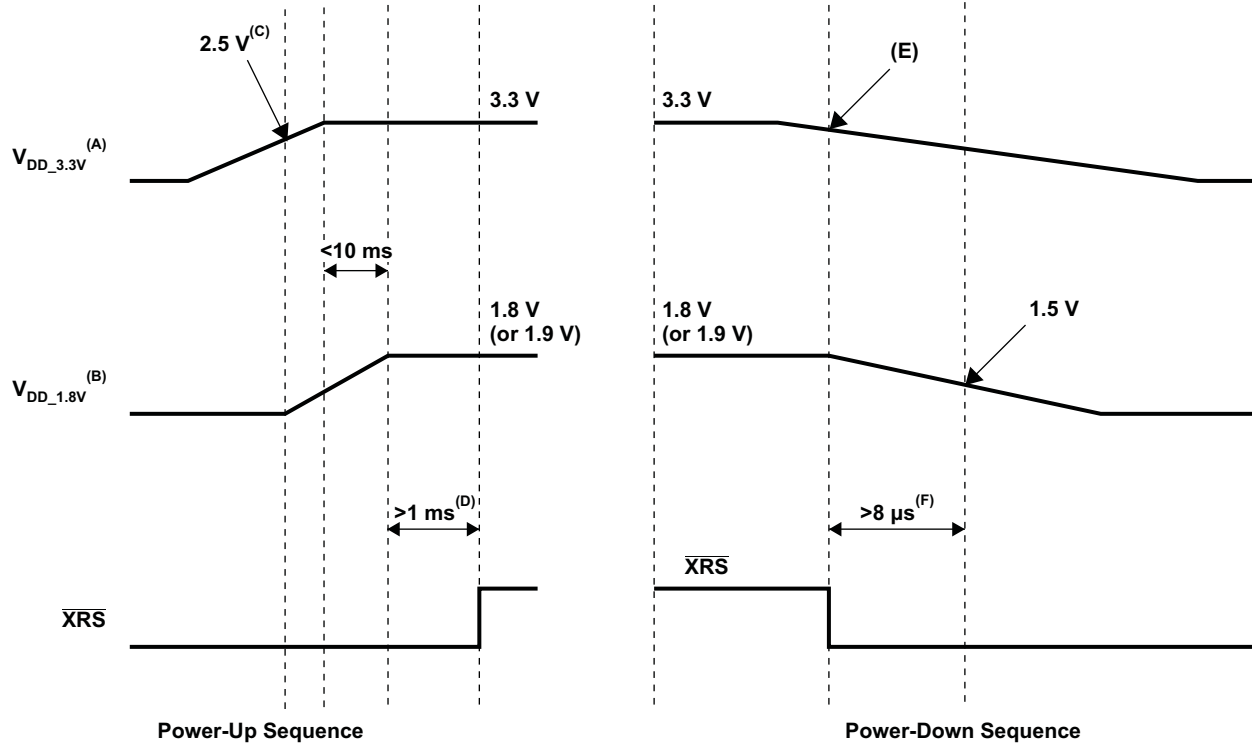

- A. $V_{\text{DD}_3.3\text{V}} - V_{\text{DDIO}}, V_{\text{DD3VFL}}, V_{\text{DDAIO}}, V_{\text{DDA1}}, V_{\text{DDA2}}, \text{AVDDREFBG}$
- B. $V_{\text{DD}_1.8\text{V}} - V_{\text{DD}}, V_{\text{DD1}}$
- C. 1.8-V (or 1.9-V) supply should ramp after the 3.3-V supply reaches at least 2.5 V.
- D. Reset ($\overline{\text{XRS}}$) should remain low until supplies and clocks are stable. See Figure 6-11, Power-on Reset in Microcomputer Mode ($\text{XMP}/\overline{\text{MC}} = 0$), for minimum requirements.
- E. Voltage supervisor or LDO reset control will trip reset ($\overline{\text{XRS}}$) first when the 3.3-V supply is off regulation. Typically, this occurs a few milliseconds before the 1.8-V (or 1.9-V) supply reaches 1.5 V.
- F. Keeping reset low ($\overline{\text{XRS}}$) at least 8 μs prior to the 1.8-V (or 1.9-V) supply reaching 1.5 V will keep the flash module in complete reset before the supplies ramp down.
- G. Since the state of GPIO pins is undefined until the 1.8-V (or 1.9-V) supply reaches at least 1 V, this supply should be ramped as quickly as possible (after the 3.3-V supply reaches at least 2.5 V).
- H. Other than the power supply pins, no pin should be driven before the 3.3-V rail has been fully powered up.

Figure 6-6. F2812/F2811/F2810 Typical Power-Up and Power-Down Sequence – Option 2

6.9 Signal Transition Levels

Note that some of the signals use different reference voltages, see the recommended operating conditions table. Output levels are driven to a minimum logic-high level of 2.4 V and to a maximum logic-low level of 0.4 V.

Figure 6-7 shows output levels.

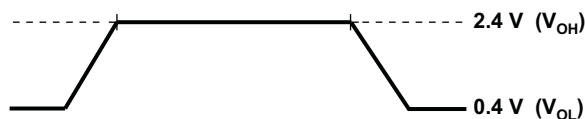

Figure 6-7. Output Levels

Output transition times are specified as follows:

- For a *high-to-low* transition, the level at which the output is said to be no longer high is below $V_{OH(MIN)}$ and the level at which the output is said to be low is $V_{OL(MAX)}$ and lower.
- For a *low-to-high* transition, the level at which the output is said to be no longer low is above $V_{OL(MAX)}$ and the level at which the output is said to be high is $V_{OH(MIN)}$ and higher.

Figure 6-8 shows the input levels.

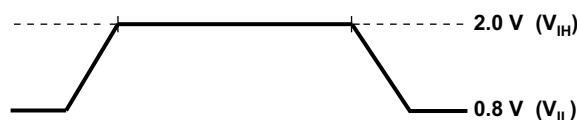

Figure 6-8. Input Levels

Input transition times are specified as follows:

- For a *high-to-low* transition on an input signal, the level at which the input is said to be no longer high is below $V_{IH(MIN)}$ and the level at which the input is said to be low is $V_{IL(MAX)}$ and lower.
- For a *low-to-high* transition on an input signal, the level at which the input is said to be no longer low is above $V_{IL(MAX)}$ and the level at which the input is said to be high is $V_{IH(MIN)}$ and higher.

NOTE

See the individual timing diagrams for levels used for testing timing parameters.

6.10 Timing Parameter Symbology

Timing parameter symbols used are created in accordance with JEDEC Standard 100. To shorten the symbols, some of the pin names and other related terminology have been abbreviated as follows:

Lowercase subscripts and their meanings:

| | |
|----|------------------------|
| a | access time |
| c | cycle time (period) |
| d | delay time |
| f | fall time |
| h | hold time |
| r | rise time |
| su | setup time |
| t | transition time |
| v | valid time |
| w | pulse duration (width) |

Letters and symbols and their meanings:

| | |
|---|--|
| H | High |
| L | Low |
| V | Valid |
| X | Unknown, changing, or don't care level |
| Z | High impedance |

6.11 General Notes on Timing Parameters

All output signals from the 28x devices (including XCLKOUT) are derived from an internal clock such that all output transitions for a given half-cycle occur with a minimum of skewing relative to each other.

The signal combinations shown in the following timing diagrams may not necessarily represent actual cycles. For actual cycle examples, see the appropriate cycle description section of this document.

6.12 Test Load Circuit

This test load circuit is used to measure all switching characteristics provided in this document.

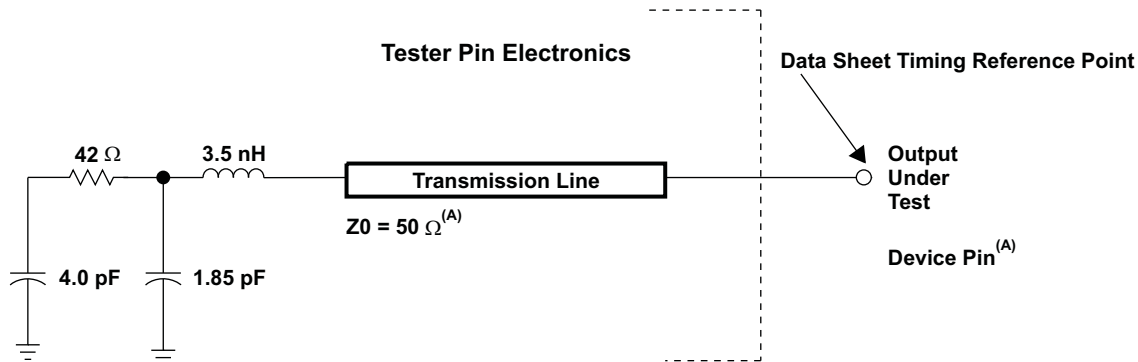

- A. The data sheet provides timing at the device pin. For output timing analysis, the tester pin electronics and its transmission line effects must be taken into account. A transmission line with a delay of 2 ns or longer can be used to produce the desired transmission line effect. The transmission line is intended as a load only. It is not necessary to add or subtract the transmission line delay (2 ns or longer) from the data sheet timing. Input requirements in this data sheet are tested with an input slew rate of < 4 Volts per nanosecond (4 V/ns) at the device pin.

Figure 6-9. 3.3-V Test Load Circuit

6.13 Device Clock Table

This section provides the timing requirements and switching characteristics for the various clock options available on the F281x and C281x DSPs. [Table 6-5](#) lists the cycle times of various clocks.

Table 6-5. TMS320F281x and TMS320C281x Clock Table and Nomenclature

| | | MIN | NOM | MAX | UNIT |
|--------------------------|---|------|---------------------|------|------|
| On chip oscillator clock | $t_{c(OSC)}$, Cycle time | 28.6 | | 50 | ns |
| | Frequency | 20 | | 35 | MHz |
| XCLKIN | $t_{c(CI)}$, Cycle time | 6.67 | | 250 | ns |
| | Frequency | 4 | | 150 | MHz |
| SYSCLKOUT | $t_{c(SCO)}$, Cycle time | 6.67 | | 500 | ns |
| | Frequency | 2 | | 150 | MHz |
| XCLKOUT | $t_{c(XCO)}$, Cycle time | 6.67 | | 2000 | ns |
| | Frequency | 0.5 | | 150 | MHz |
| HSPCLK | $t_{c(HCO)}$, Cycle time | 6.67 | 13.3 ⁽¹⁾ | | ns |
| | Frequency | | 75 ⁽¹⁾ | 150 | MHz |
| LSPCLK | $t_{c(LCO)}$, Cycle time | 13.3 | 26.6 ⁽¹⁾ | | ns |
| | Frequency | | 37.5 ⁽¹⁾ | 75 | MHz |
| ADC clock | $t_{c(ADCCLK)}$, Cycle time ⁽²⁾ | 40 | | | ns |
| | Frequency | | | 25 | MHz |
| SPI clock | $t_{c(SPC)}$, Cycle time | 50 | | | ns |
| | Frequency | | | 20 | MHz |
| McBSP | $t_{c(CKG)}$, Cycle time | 50 | | | ns |
| | Frequency | | | 20 | MHz |
| XTIMCLK | $t_{c(XTIM)}$, Cycle time | 6.67 | | | ns |
| | Frequency | | | 150 | MHz |

(1) This is the default reset value if SYSCLKOUT = 150 MHz.

(2) The maximum value for ADCCLK frequency is 25 MHz. For SYSCLKOUT values of 25 MHz or lower, ADCCLK has to be SYSCLKOUT/2 or lower. ADCCLK = SYSCLKOUT is not a valid mode for any value of SYSCLKOUT.

6.14 Clock Requirements and Characteristics

6.14.1 Input Clock Requirements

The clock provided at the XCLKIN pin generates the internal CPU clock cycle.

Table 6-6. Input Clock Frequency

| PARAMETER | | MIN | TYP | MAX | UNIT |
|----------------|---------------------------|-------------|-----|-----|------|
| f _x | Input clock frequency | Resonator | | 35 | MHz |
| | | Crystal | 20 | 35 | |
| | XCLKIN | Without PLL | 4 | 150 | |
| | | With PLL | 5 | 100 | |
| f _l | Limp mode clock frequency | | 2 | | MHz |

Table 6-7. XCLKIN Timing Requirements – PLL Bypassed or Enabled

| NO. | | MIN | MAX | UNIT |
|-----|--|------|-----|------|
| C8 | t _{c(CI)} Cycle time, XCLKIN | 6.67 | 250 | ns |
| C9 | t _{f(CI)} Fall time, XCLKIN | | 6 | ns |
| C10 | t _{r(CI)} Rise time, XCLKIN | | 6 | ns |
| C11 | t _{w(CIL)} Pulse duration, X1/XCLKIN low as a percentage of t _{c(CI)} | 40 | 60 | % |
| C12 | t _{w(CIH)} Pulse duration, X1/XCLKIN high as a percentage of t _{c(CI)} | 40 | 60 | % |

Table 6-8. XCLKIN Timing Requirements – PLL Disabled

| NO. | | MIN | MAX | UNIT |
|-----|--|------------------------|-----|------|
| C8 | t _{c(CI)} Cycle time, XCLKIN | 6.67 | 250 | ns |
| C9 | t _{f(CI)} Fall time, XCLKIN | Up to 30 MHz | 6 | ns |
| | | 30 MHz to 150 MHz | 2 | |
| C10 | t _{r(CI)} Rise time, XCLKIN | Up to 30 MHz | 6 | ns |
| | | 30 MHz to 150 MHz | 2 | |
| C11 | t _{w(CIL)} Pulse duration, X1/XCLKIN low as a percentage of t _{c(CI)} | XCLKIN ≤ 120 MHz | 40 | % |
| | | 120 < XCLKIN ≤ 150 MHz | 45 | |
| C12 | t _{w(CIH)} Pulse duration, X1/XCLKIN high as a percentage of t _{c(CI)} | XCLKIN ≤ 120 MHz | 40 | % |
| | | 120 < XCLKIN ≤ 150 MHz | 45 | |

Table 6-9. Possible PLL Configuration Modes

| PLL MODE | REMARKS | SYSCLKOUT |
|--------------|--|------------------|
| PLL Disabled | Invoked by tying $\overline{\text{XPLLDIS}}$ pin low upon reset. PLL block is completely disabled. Clock input to the CPU (CLKIN) is directly derived from the clock signal present at the X1/XCLKIN pin. | XCLKIN |
| PLL Bypassed | Default PLL configuration upon power-up, if PLL is not disabled. The PLL itself is bypassed. However, the /2 module in the PLL block divides the clock input at the X1/XCLKIN pin by two before feeding it to the CPU. | XCLKIN/2 |
| PLL Enabled | Achieved by writing a non-zero value “n” into PLLCR register. The /2 module in the PLL block now divides the output of the PLL by two before feeding it to the CPU. | (XCLKIN * n) / 2 |

6.14.2 Output Clock Characteristics

Table 6-10. XCLKOUT Switching Characteristics (PLL Bypassed or Enabled)⁽¹⁾⁽²⁾

| NO. | PARAMETER | | MIN | TYP | MAX | UNIT |
|-----|---------------|------------------------------|---------------------|-----|--------------------|------|
| C1 | $t_{c(XCO)}$ | Cycle time, XCLKOUT | 6.67 ⁽³⁾ | | | ns |
| C3 | $t_{f(XCO)}$ | Fall time, XCLKOUT | | 2 | | ns |
| C4 | $t_{r(XCO)}$ | Rise time, XCLKOUT | | 2 | | ns |
| C5 | $t_{w(XCOL)}$ | Pulse duration, XCLKOUT low | H – 2 | | H + 2 | ns |
| C6 | $t_{w(XCOH)}$ | Pulse duration, XCLKOUT high | H – 2 | | H + 2 | ns |
| C7 | t_p | PLL lock time ⁽⁴⁾ | | | 131072 $t_{c(CI)}$ | ns |

- (1) A load of 40 pF is assumed for these parameters.
- (2) $H = 0.5t_{c(XCO)}$
- (3) The PLL must be used for maximum frequency operation.
- (4) This parameter has changed from 4096 XCLKIN cycles in the earlier revisions of the silicon.

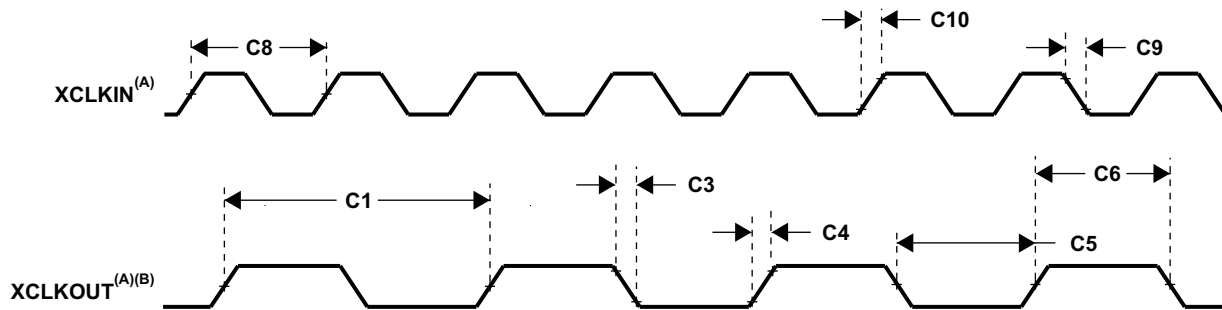

- A. The relationship of XCLKIN to XCLKOUT depends on the divide factor chosen. The waveform relationship shown in Figure 6-10 is intended to illustrate the timing parameters only and may differ based on configuration.
- B. XCLKOUT configured to reflect SYSCLKOUT.

Figure 6-10. Clock Timing

6.15 Reset Timing

Table 6-11. Reset (\overline{XRS}) Timing Requirements⁽¹⁾

| | | | MIN | NOM | MAX | UNIT |
|----------------------------|--|------------|---------------------------------|-----------------|-----|--------|
| $t_{w(RSL1)}$ | Pulse duration, stable XCLKIN to \overline{XRS} high | | 8 $t_{c(CI)}$ | | | cycles |
| $t_{w(RSL2)}$ | Pulse duration, \overline{XRS} low | Warm reset | 8 $t_{c(CI)}$ | | | cycles |
| $t_{w(WDRS)}$ | Pulse duration, reset pulse generated by watchdog | | | 512 $t_{c(CI)}$ | | cycles |
| $t_{d(EX)}$ | Delay time, address/data valid after \overline{XRS} high | | | 32 $t_{c(CI)}$ | | cycles |
| t_{OSCST} ⁽²⁾ | Oscillator start-up time | | 1 | 10 | | ms |
| $t_{su(XPLLDIS)}$ | Setup time for $\overline{XPLLDIS}$ pin | | 16 $t_{c(CI)}$ | | | cycles |
| $t_{h(XPLLDIS)}$ | Hold time for $\overline{XPLLDIS}$ pin | | 16 $t_{c(CI)}$ | | | cycles |
| $t_{h(XMP/MC)}$ | Hold time for XMP/ \overline{MC} pin | | 16 $t_{c(CI)}$ | | | cycles |
| $t_{h(boot-mode)}$ | Hold time for boot-mode pins | | 2520 $t_{c(CI)}$ ⁽³⁾ | | | cycles |

- (1) If external oscillator/clock source are used, reset time has to be low at least for 1 ms after V_{DD} reaches 1.5 V.
- (2) Dependent on crystal/resonator and board design.
- (3) The boot ROM reads the password locations. Therefore, this timing requirement includes the wakeup time for flash. See the *TMS320x281x DSP Boot ROM Reference Guide* (literature number [SPRU095](#)) and the *TMS320x281x DSP System Control and Interrupts Reference Guide* (literature number [SPRU078](#)) for further information.

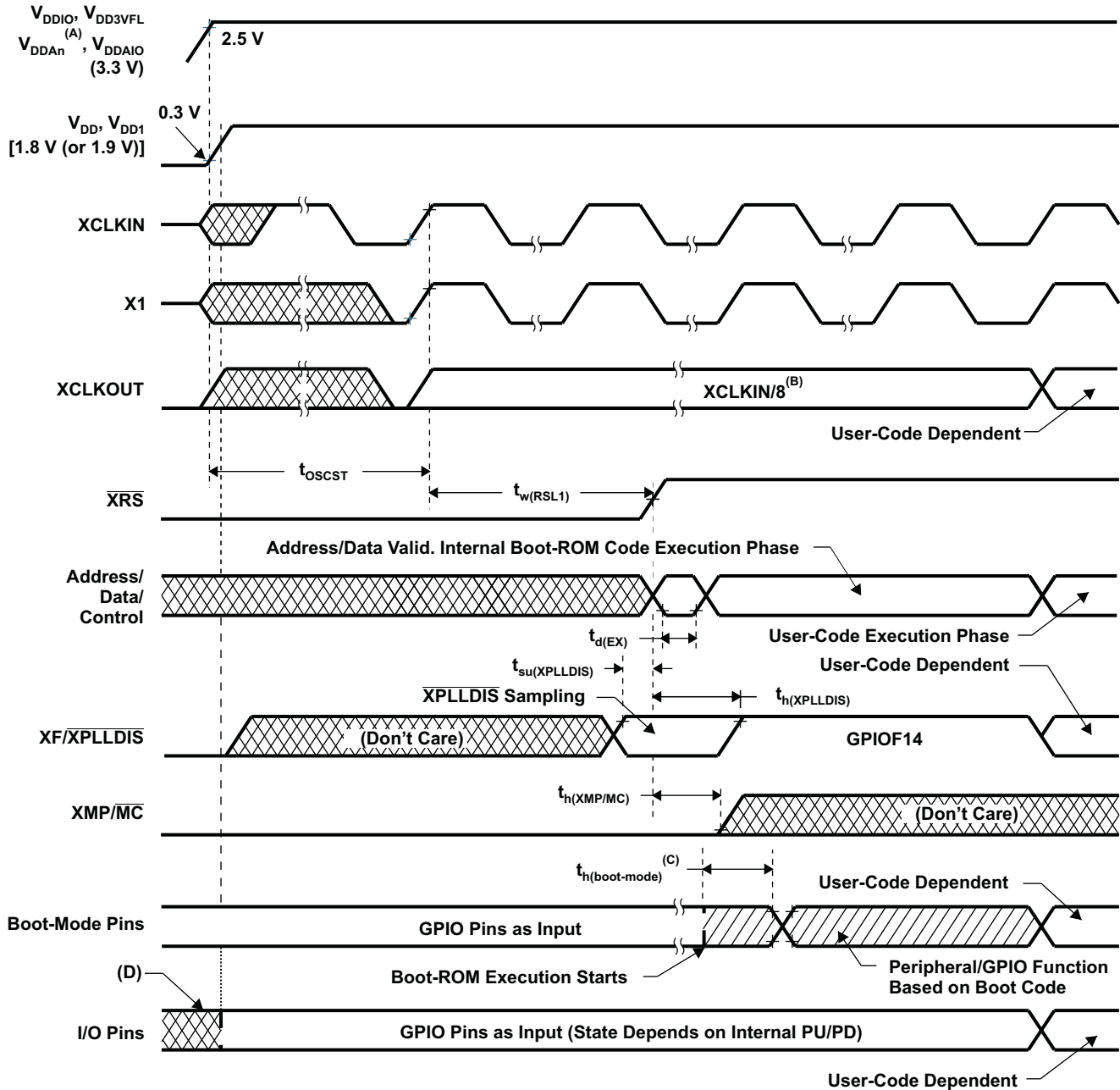

- $V_{DDAn} - V_{DDA1}/V_{DDA2}$ and AVDDREFBG
- Upon power up, SYSCLOCKOUT is XCLKIN/2 if the PLL is enabled. Since both the XTIMCLK and CLKMODE bits in the XINTCNF2 register come up with a reset state of 1, SYSCLOCKOUT is further divided by 4 before it appears at XCLKOUT. This explains why XCLKOUT = XCLKIN/8 during this phase.
- After reset, the Boot ROM code executes instructions for 1260 SYSCLOCKOUT cycles (SYSCLOCKOUT = XCLKIN/2) and then samples BOOT Mode pins. Based on the status of the Boot Mode pin, the boot code branches to destination memory or boot code function in ROM. The BOOT Mode pins should be held high/low for at least 2520 XCLKIN cycles from boot ROM execution time for proper selection of Boot modes. If Boot ROM code executes after power-on conditions (in debugger environment), the Boot code execution time is based on the current SYSCLOCKOUT speed. The SYSCLOCKOUT will be based on user environment and could be with or without PLL enabled.
- The state of the GPIO pins is undefined (that is, they could be input or output) until the 1.8-V (or 1.9-V) supply reaches at least 1 V and 3.3-V supply reaches 2.5 V.

Figure 6-11. Power-on Reset in Microcomputer Mode (XMP/MC = 0) (See Note D)

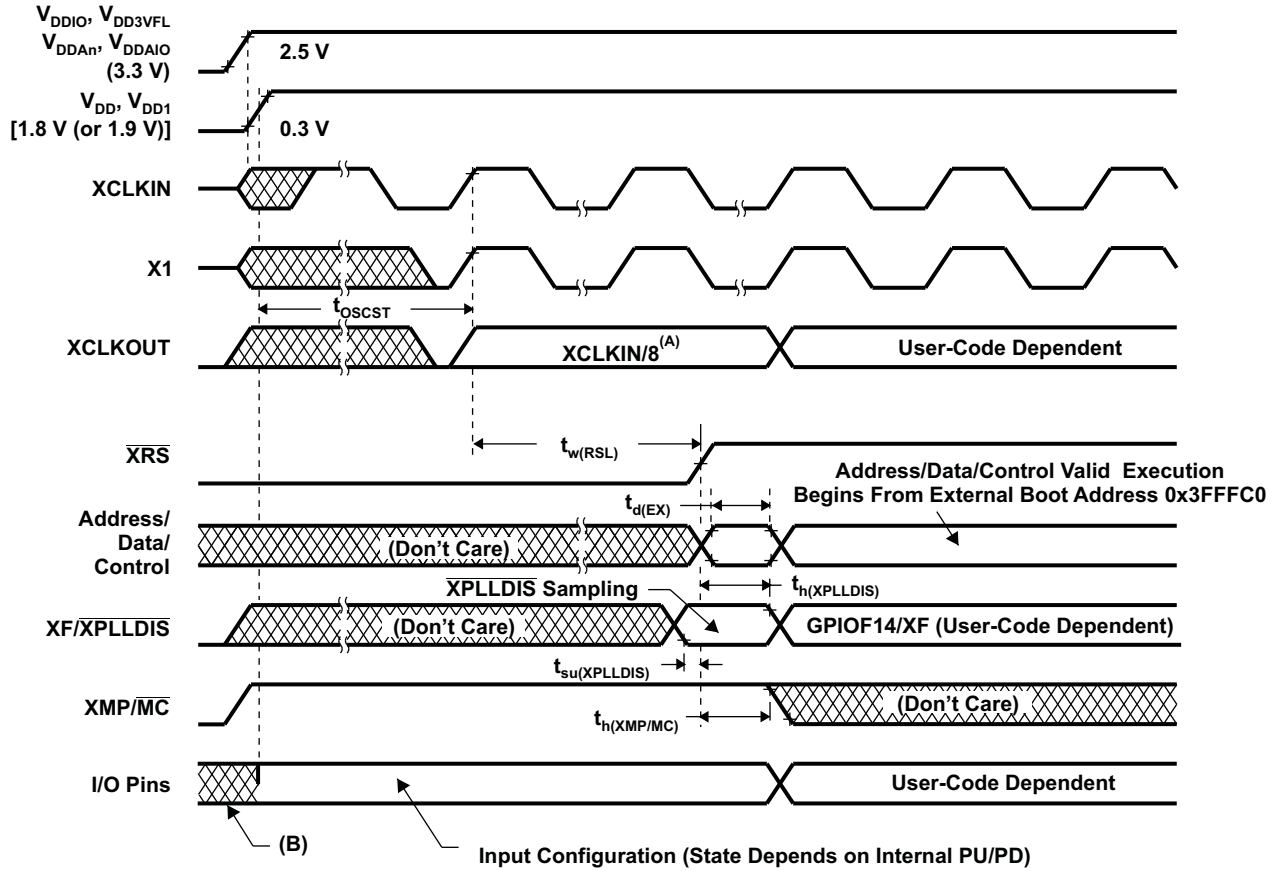

- A. Upon power up, SYSCLKOUT is XCLKIN/2 if the PLL is enabled. Since both the XTIMCLK and CLKMODE bits in the XINTCNF2 register come up with a reset state of 1, SYSCLKOUT is further divided by 4 before it appears at XCLKOUT. This explains why XCLKOUT = XCLKIN/8 during this phase.
- B. The state of the GPIO pins is undefined (that is, they could be input or output) until the 1.8-V (or 1.9-V) supply reaches at least 1 V and 3.3-V supply reaches 2.5 V.

Figure 6-12. Power-on Reset in Microprocessor Mode (XMP/MC = 1)

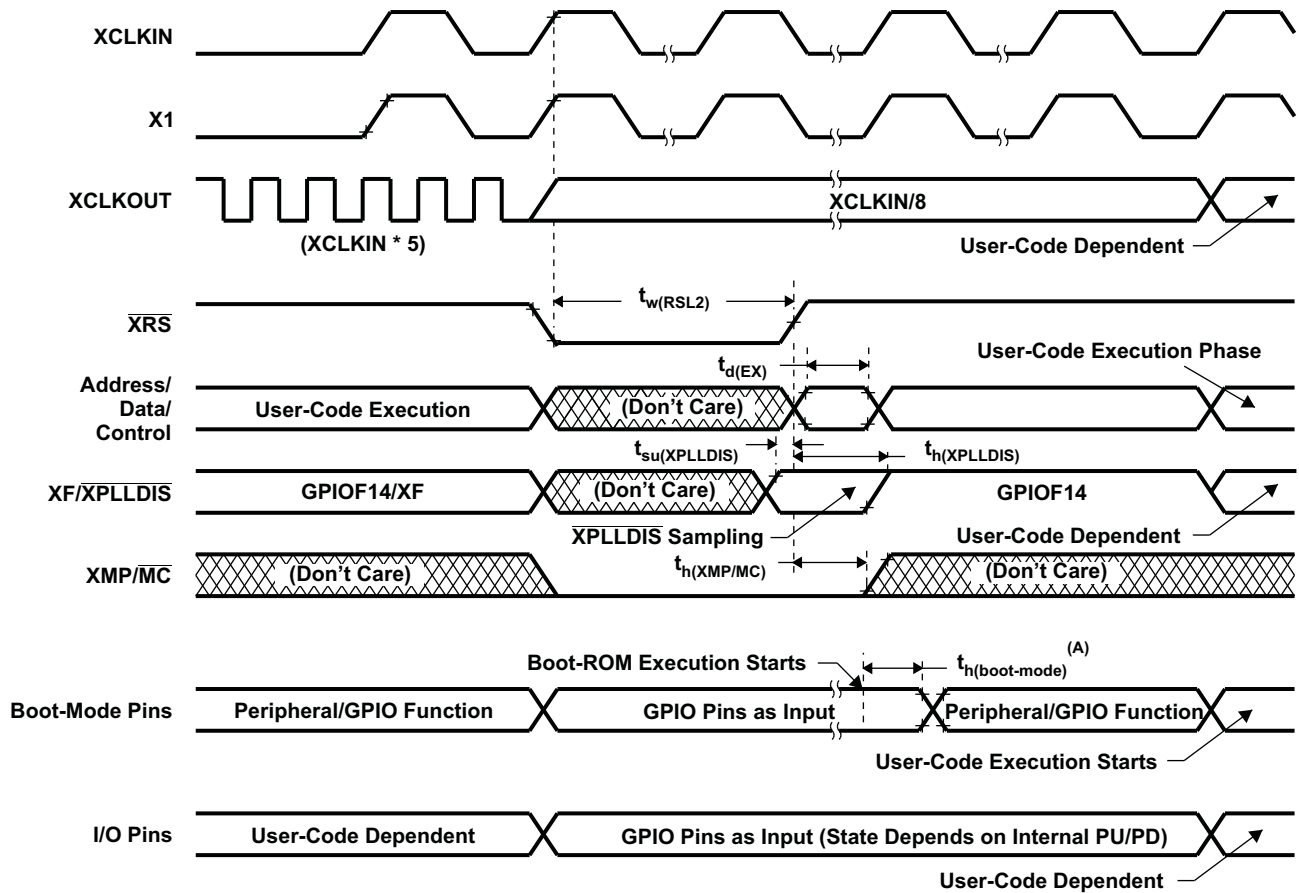

- A. After reset, the Boot ROM code executes instructions for 1260 SYSCLOCKOUT cycles ($SYSCLOCKOUT = XCLKIN/2$) and then samples BOOT Mode pins. Based on the status of the Boot Mode pin, the boot code branches to destination memory or boot code function in ROM. The BOOT Mode pins should be held high/low for at least 2520 XCLKIN cycles from boot ROM execution time for proper selection of Boot modes. If Boot ROM code executes after power-on conditions (in debugger environment), the Boot code execution time is based on the current SYSCLOCKOUT speed. The SYSCLOCKOUT will be based on user environment and could be with or without PLL enabled.

Figure 6-13. Warm Reset in Microcomputer Mode

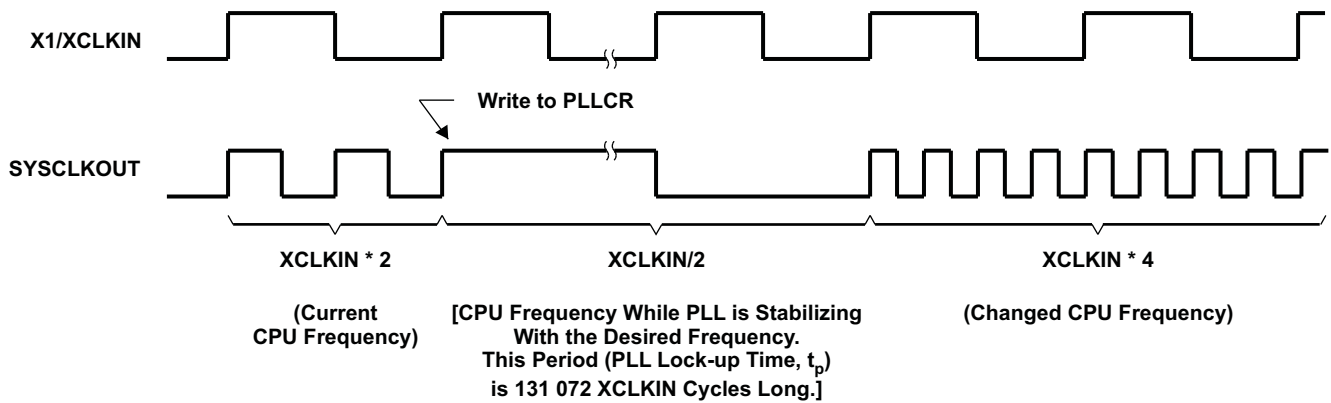

Figure 6-14. Effect of Writing Into PLLCR Register

6.16 Low-Power Mode Wakeup Timing

Table 6-12. IDLE Mode Timing Requirements

| | | MIN | NOM | MAX | UNIT |
|--------------------------|---|-------------------------|---|-----|--------|
| $t_{w(\text{WAKE-INT})}$ | Pulse duration, external wake-up signal | | | | cycles |
| | | Without input qualifier | $2t_{c(\text{SCO})}$ | | |
| | | With input qualifier | $1t_{c(\text{SCO})} + \text{IQT}^{(1)}$ | | |

(1) Input Qualification Time (IQT) = $[t_{c(\text{SCO})} \times 2 \times \text{QUALPRD}] \times 5 + [t_{c(\text{SCO})} \times 2 \times \text{QUALPRD}]$.

Table 6-13. IDLE Mode Switching Characteristics

| PARAMETER | | TEST CONDITIONS | MIN | TYP | MAX | UNIT |
|---------------------------|---|-------------------------|-----|---|--|--------|
| $t_{d(\text{WAKE-IDLE})}$ | Delay time, external wake signal to program execution resume ⁽¹⁾ | | | | | |
| | • Wake-up from Flash – Flash module in active state | Without input qualifier | | | $8t_{c(\text{SCO})}$ | cycles |
| | | With input qualifier | | | $8t_{c(\text{SCO})} + \text{IQT}^{(2)}$ | |
| | • Wake-up from Flash – Flash module in sleep state | Without input qualifier | | | $1050t_{c(\text{SCO})}$ | cycles |
| | | With input qualifier | | | $1050t_{c(\text{SCO})} + \text{IQT}^{(2)}$ | |
| | • Wake-up from SARAM | Without input qualifier | | | $8t_{c(\text{SCO})}$ | cycles |
| With input qualifier | | | | $8t_{c(\text{SCO})} + \text{IQT}^{(2)}$ | | |

(1) This is the time taken to begin execution of the instruction that immediately follows the IDLE instruction. Execution of an ISR (triggered by the wake-up) signal involves additional latency.

(2) Input Qualification Time (IQT) = $[t_{c(\text{SCO})} \times 2 \times \text{QUALPRD}] \times 5 + [t_{c(\text{SCO})} \times 2 \times \text{QUALPRD}]$.

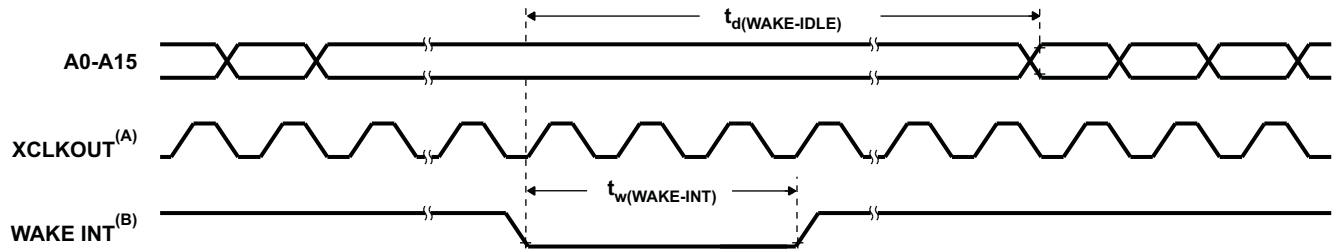

A. XCLKOUT = SYSCLKOUT

B. WAKE INT can be any enabled interrupt, $\overline{\text{WDINT}}$, XNMI, or $\overline{\text{XRS}}$.

Figure 6-15. IDLE Entry and Exit Timing

Table 6-14. STANDBY Mode Timing Requirements

| | | | MIN | NOM | MAX | UNIT |
|-------------------|---|-------------------------|--|-----|-----|--------|
| $t_{w(WAKE-INT)}$ | Pulse duration, external wake-up signal | Without input qualifier | 12 $t_{c(CI)}$ | | | cycles |
| | | With input qualifier | (2 + QUALSTDBY) * $t_{c(CI)}$ ⁽¹⁾ | | | |

(1) QUALSTDBY is a 6-bit field in the LPMCR0 register.

Table 6-15. STANDBY Mode Switching Characteristics

| PARAMETER | | TEST CONDITIONS | MIN | TYP | MAX | UNIT |
|----------------------|---|------------------------------------|---------------------------------------|-----|-----------------|--------|
| $t_{d(IDLE-XCOH)}$ | Delay time, IDLE instruction executed to XCLKOUT high | | 32 $t_{c(SCO)}$ | | 45 $t_{c(SCO)}$ | cycles |
| $t_{d(WAKE-STBY)}$ | Delay time, external wake signal to program execution resume ⁽¹⁾ | | | | | |
| | • Wake-up from Flash – Flash module in active state | Without input qualifier | 12 $t_{c(CI)}$ | | | cycles |
| | | With input qualifier | 12 $t_{c(CI)}$ + $t_{w(WAKE-INT)}$ | | | |
| | • Wake-up from Flash – Flash module in sleep state | Without input qualifier | 1125 $t_{c(SCO)}$ | | | cycles |
| | | With input qualifier | 1125 $t_{c(SCO)}$ + $t_{w(WAKE-INT)}$ | | | |
| | • Wake-up from SARAM | Without input qualifier | 12 $t_{c(CI)}$ | | | cycles |
| With input qualifier | | 12 $t_{c(CI)}$ + $t_{w(WAKE-INT)}$ | | | | |

(1) This is the time taken to begin execution of the instruction that immediately follows the IDLE instruction. Execution of an ISR (triggered by the wake-up) signal involves additional latency.

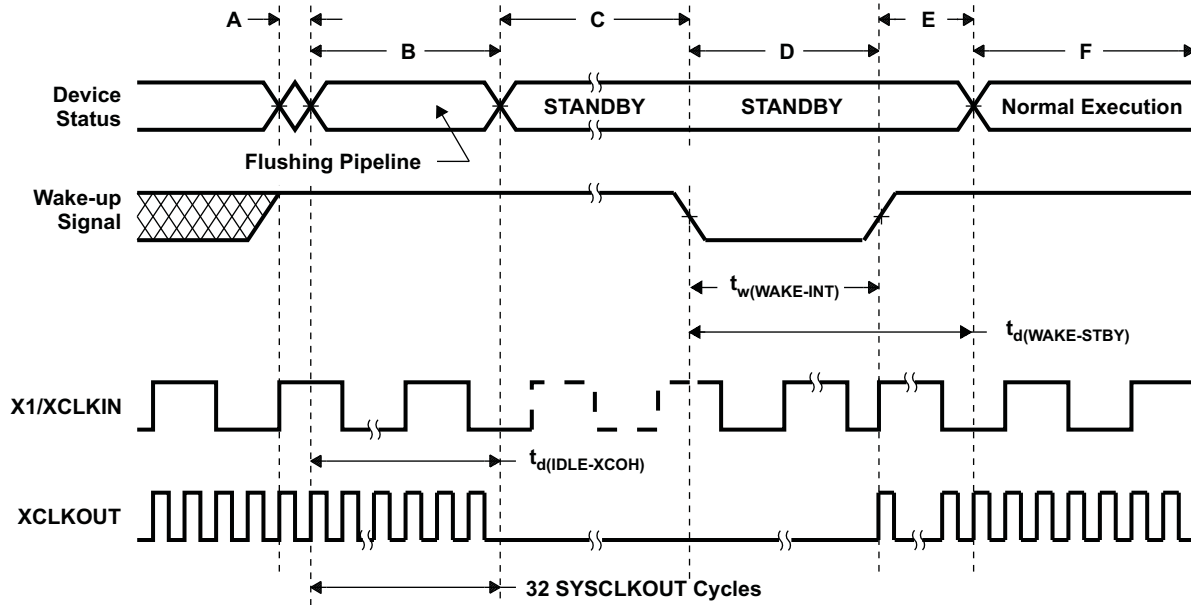

- A. IDLE instruction is executed to put the device into STANDBY mode.
- B. The PLL block responds to the STANDBY signal. SYSCLKOUT is held for the number of cycles indicated below before being turned off:
 - 16 cycles, when DIVSEL = 00 or 01
 - 32 cycles, when DIVSEL = 10
 - 64 cycles, when DIVSEL = 11
 This delay enables the CPU pipeline and any other pending operations to flush properly. If an access to XINTF is in progress and its access time is longer than this number, then it will fail. It is recommended that STANDBY mode be entered from SARAM without an XINTF access in progress.
- C. Clocks to the peripherals are turned off. However, the PLL and watchdog are not shut down. The device is now in STANDBY mode.
- D. The external wake-up signal is driven active.
- E. After a latency period, the STANDBY mode is exited.
- F. Normal execution resumes. The device will respond to the interrupt (if enabled).

Figure 6-16. STANDBY Entry and Exit Timing

Table 6-16. HALT Mode Timing Requirements

| | | MIN | NOM | MAX | UNIT |
|---------------------------|------------------------------------|---------------------|-----|-----|--------|
| $t_{w(\text{WAKE-XNMI})}$ | Pulse duration, XNMI wakeup signal | $2t_{c(\text{Cl})}$ | | | cycles |
| $t_{w(\text{WAKE-XRS})}$ | Pulse duration, XRS wakeup signal | $8t_{c(\text{Cl})}$ | | | cycles |

Table 6-17. HALT Mode Switching Characteristics

| PARAMETER | MIN | TYP | MAX | UNIT |
|---------------------------|---|-----------------------|--------------------------|--------|
| $t_{d(\text{IDLE-XCOH})}$ | Delay time, IDLE instruction executed to XCLKOUT high | $32t_{c(\text{SCO})}$ | $45t_{c(\text{SCO})}$ | cycles |
| t_p | PLL lock-up time | | $131072t_{c(\text{Cl})}$ | cycles |
| $t_{d(\text{WAKE})}$ | Delay time, PLL lock to program execution resume | | | |
| | <ul style="list-style-type: none"> Wake up from flash – Flash module in sleep state | | $1125t_{c(\text{SCO})}$ | cycles |
| | <ul style="list-style-type: none"> Wake up from SARAM | | $35t_{c(\text{SCO})}$ | cycles |

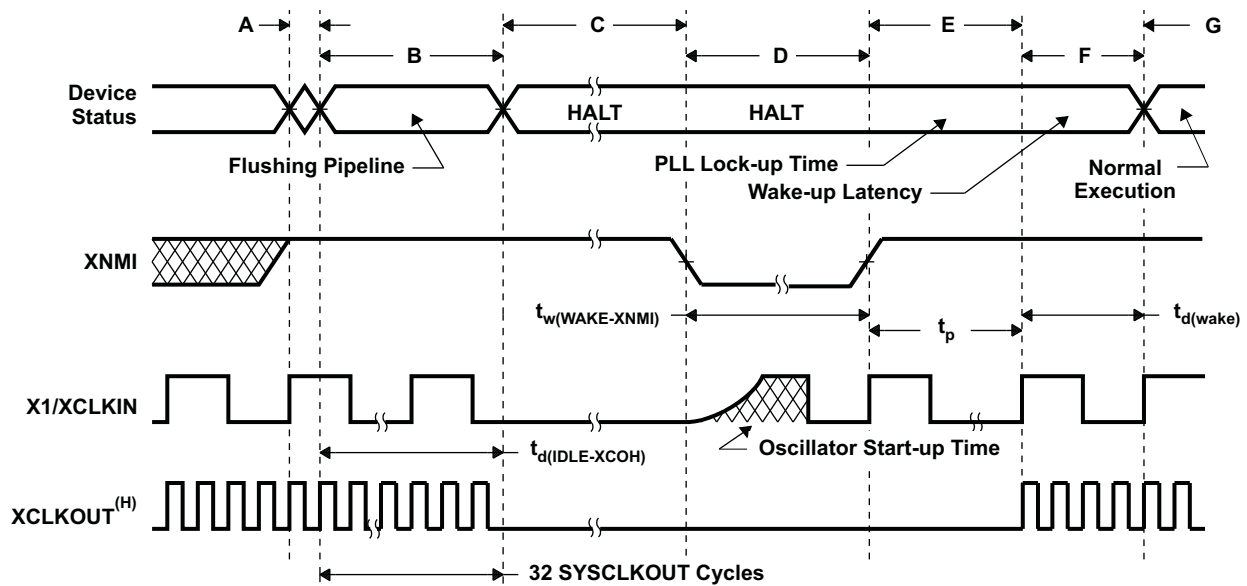

- IDLE instruction is executed to put the device into HALT mode.
- The PLL block responds to the HALT signal. SYSCLKOUT is held for another 32 cycles before the oscillator is turned off and the CLKIN to the core is stopped. This 32-cycle delay enables the CPU pipe and any other pending operations to flush properly.
- Clocks to the peripherals are turned off and the internal oscillator and PLL are shut down. The device is now in HALT mode and consumes absolute minimum power.
- When XNMI is driven active, the oscillator is turned on; but the PLL is not activated. The pulse duration of $2t_{c(\text{Cl})}$ is applicable when an external oscillator is used. If the internal oscillator is used, the oscillator wake-up time should be added to this parameter.
- When XNMI is deactivated, it initiates the PLL lock sequence, which takes 131,072 X1/XCLKIN cycles.
- When CLKIN to the core is enabled, the device will respond to the interrupt (if enabled), after a latency. The HALT mode is now exited.
- Normal operation resumes.
- XCLKOUT = SYSCLKOUT

Figure 6-17. HALT Wakeup Using XNMI

6.17 Event Manager Interface

6.17.1 PWM Timing

PWM refers to all PWM outputs on EVA and EVB.

Table 6-18. PWM Switching Characteristics⁽¹⁾⁽²⁾

| PARAMETER | TEST CONDITIONS | MIN | MAX | UNIT |
|--------------------|---|-----|-----|------|
| $t_{w(PWM)}^{(3)}$ | Pulse duration, PWMx output high/low | 25 | | ns |
| $t_{d(PWM)XCO}$ | Delay time, XCLKOUT high to PWMx output switching | | 10 | ns |

- (1) See the GPIO output timing for fall/rise times for PWM pins.
(2) PWM pin toggling frequency is limited by the GPIO output buffer switching frequency (20 MHz).
(3) PWM outputs may be 100%, 0%, or increments of $t_{c(HCO)}$ with respect to the PWM period.

Table 6-19. Timer and Capture Unit Timing Requirements⁽¹⁾⁽²⁾

| | | MIN | MAX | UNIT |
|------------------|--|-------------------------|---------------------------|--------|
| $t_{w(TDIR)}$ | Pulse duration, TDIRx low/high | Without input qualifier | $2t_{c(SCO)}$ | cycles |
| | | With input qualifier | $1t_{c(SCO)} + IQT^{(3)}$ | |
| $t_{w(CAP)}$ | Pulse duration, CAPx input low/high | Without input qualifier | $2t_{c(SCO)}$ | cycles |
| | | With input qualifier | $1t_{c(SCO)} + IQT^{(3)}$ | |
| $t_{w(TCLKINL)}$ | Pulse duration, TCLKINx low as a percentage of TCLKINx cycle time | 40 | 60 | % |
| $t_{w(TCLKINH)}$ | Pulse duration, TCLKINx high as a percentage of TCLKINx cycle time | 40 | 60 | % |
| $t_{c(TCLKIN)}$ | Cycle time, TCLKINx | $4t_{c(HCO)}$ | | ns |

- (1) The QUALPRD bit field value can range from 0 (no qualification) through 0xFF (510 SYSCLOCKOUT cycles). The qualification sampling period is $2n$ SYSCLOCKOUT cycles, where "n" is the value stored in the QUALPRD bit field. As an example, when QUALPRD = 1, the qualification sampling period is $1 \times 2 = 2$ SYSCLOCKOUT cycles (that is, the input is sampled every 2 SYSCLOCKOUT cycles). Six such samples will be taken over five sampling windows, each window being $2n$ SYSCLOCKOUT cycles. For QUALPRD = 1, the minimum width that is needed is $5 \times 2 = 10$ SYSCLOCKOUT cycles. However, since the external signal is driven asynchronously, a 11-SYSCLOCKOUT-wide pulse ensures reliable recognition.
(2) Maximum input frequency to the QEP = $\min[HSPCLK/2, 20 \text{ MHz}]$
(3) Input Qualification Time (IQT) = $[t_{c(SCO)} \times 2 \times \text{QUALPRD}] \times 5 + [t_{c(SCO)} \times 2 \times \text{QUALPRD}]$.

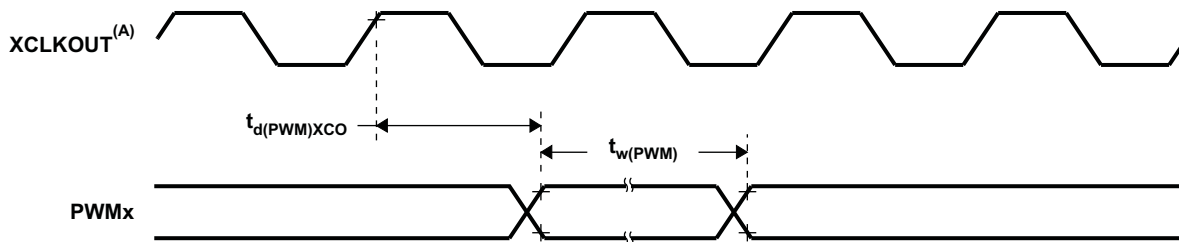

A. XCLKOUT = SYSCLOCKOUT

Figure 6-18. PWM Output Timing

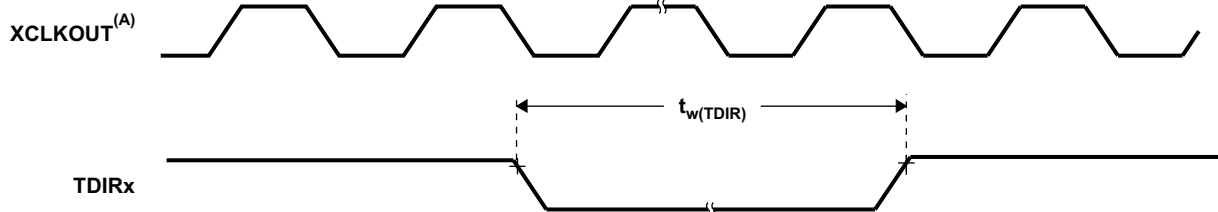

A. XCLKOUT = SYSCLOCKOUT

Figure 6-19. TDIRx Timing

Table 6-20. External ADC Start-of-Conversion – EVA – Switching Characteristics⁽¹⁾

| PARAMETER | | MIN | MAX | UNIT |
|-----------------------|---|----------------|---------------|-------|
| $t_{d(XCOH-EVASOCL)}$ | Delay time, XCLKOUT high to \overline{EVASOC} low | | $1t_{c(SCO)}$ | cycle |
| $t_{w(EVASOCL)}$ | Pulse duration, \overline{EVASOC} low | $32t_{c(HCO)}$ | | ns |

(1) XCLKOUT = SYSCLKOUT

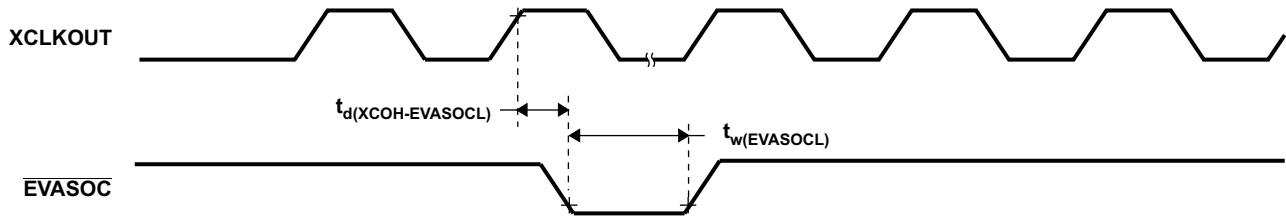

Figure 6-20. \overline{EVASOC} Timing

Table 6-21. External ADC Start-of-Conversion – EVB – Switching Characteristics⁽¹⁾

| PARAMETER | | MIN | MAX | UNIT |
|-----------------------|---|----------------|---------------|-------|
| $t_{d(XCOH-EVBSOCL)}$ | Delay time, XCLKOUT high to \overline{EVBSOC} low | | $1t_{c(SCO)}$ | cycle |
| $t_{w(EVBSOCL)}$ | Pulse duration, \overline{EVBSOC} low | $32t_{c(HCO)}$ | | ns |

(1) XCLKOUT = SYSCLKOUT

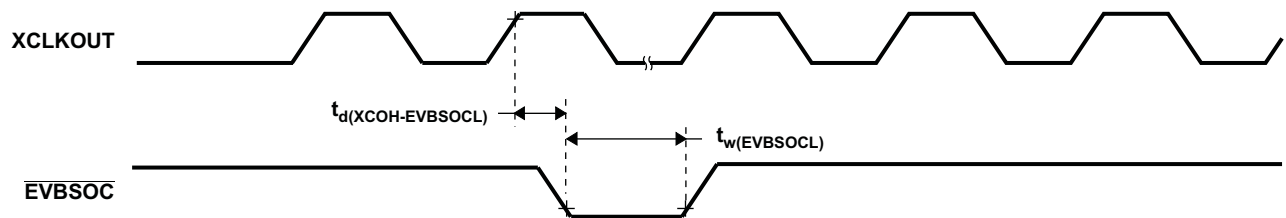

Figure 6-21. \overline{EVBSOC} Timing

6.17.2 Interrupt Timing

Table 6-22. Interrupt Switching Characteristics

| PARAMETER | | | MIN | MAX | UNIT |
|---------------------|--|-------------------------|-----|--------------------------------|------|
| $t_{d(PDP-PWM)HZ}$ | Delay time, $\overline{PDPINTx}$ low to PWM high-impedance state | Without input qualifier | | 12 | ns |
| | | With input qualifier | | $1t_{c(SCO)} + IQT + 12^{(1)}$ | |
| $t_{d(TRIP-PWM)HZ}$ | Delay time, $\overline{CxTRIP}/\overline{TxCTRIP}$ signals low to PWM high-impedance state | Without input qualifier | | $3 * t_{c(SCO)}$ | ns |
| | | With input qualifier | | $2t_{c(SCO)} + IQT^{(1)}$ | |
| $t_{d(INT)}$ | Delay time, INT low/high to interrupt-vector fetch | | | $IQT + 12t_{c(SCO)}^{(1)}$ | ns |

(1) Input Qualification Time (IQT) = $[t_{c(SCO)} \times 2 \times QUALPRD] \times 5 + [t_{c(SCO)} \times 2 \times QUALPRD]$.

Table 6-23. Interrupt Timing Requirements

| | | | MIN | MAX | UNIT |
|------------------|--|-------------------|-----|---------------------------|--------|
| $t_{w(INT)}$ | Pulse duration, INT input low/high | With no qualifier | | $2t_{c(SCO)}$ | cycles |
| | | With qualifier | | $1t_{c(SCO)} + IQT^{(1)}$ | |
| $t_{w(PDP)}$ | Pulse duration, $\overline{PDPINTx}$ input low | With no qualifier | | $2t_{c(SCO)}$ | cycles |
| | | With qualifier | | $1t_{c(SCO)} + IQT^{(1)}$ | |
| $t_{w(CxTRIP)}$ | Pulse duration, \overline{CxTRIP} input low | With no qualifier | | $2t_{c(SCO)}$ | cycles |
| | | With qualifier | | $1t_{c(SCO)} + IQT^{(1)}$ | |
| $t_{w(TxCTRIP)}$ | Pulse duration, $\overline{TxCTRIP}$ input low | With no qualifier | | $2t_{c(SCO)}$ | cycles |
| | | With qualifier | | $1t_{c(SCO)} + IQT^{(1)}$ | |

(1) Input Qualification Time (IQT) = $[t_{c(SCO)} \times 2 \times QUALPRD] \times 5 + [t_{c(SCO)} \times 2 \times QUALPRD]$.

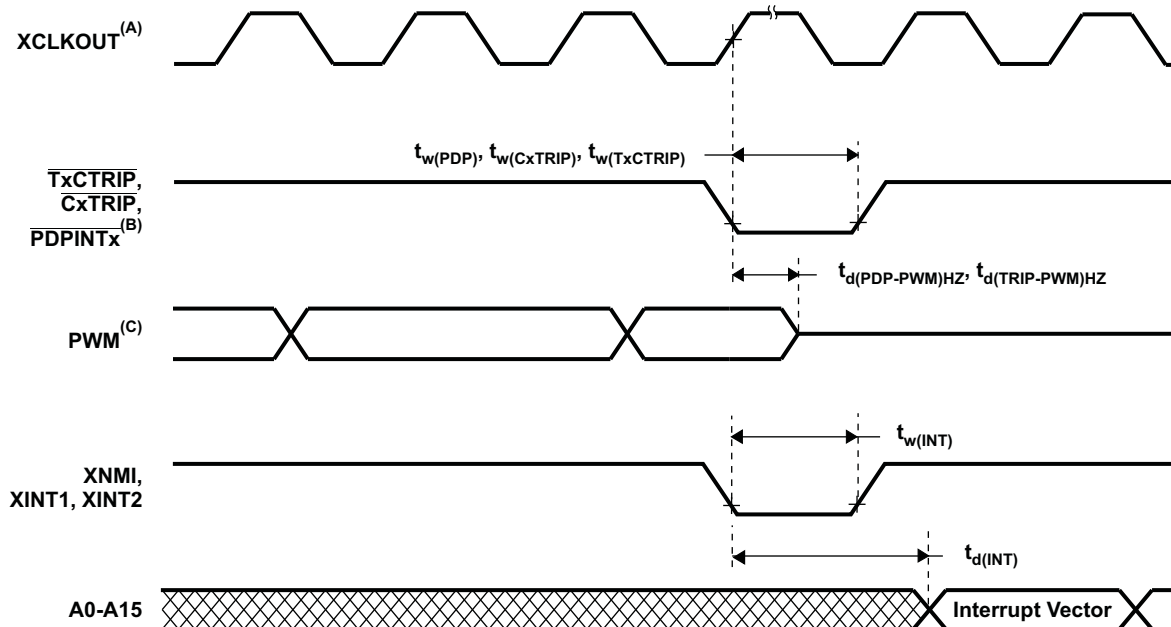

- A. XCLKOUT = SYSCLKOUT
- B. $\overline{TxCTRIP}$ – $\overline{T1CTRIP}$, $\overline{T2CTRIP}$, $\overline{T3CTRIP}$, $\overline{T4CTRIP}$
 \overline{CxTRIP} – $\overline{C1TRIP}$, $\overline{C2TRIP}$, $\overline{C3TRIP}$, $\overline{C4TRIP}$, $\overline{C5TRIP}$, or $\overline{C6TRIP}$
 $\overline{PDPINTx}$ – $\overline{PDPINTA}$ or $\overline{PDPINTB}$
- C. PWM refers to **all** the PWM pins in the device (that is, PWMn and TnPWM pins or PWM pin pair relevant to each CxTRIP pin). The state of the PWM pins after $\overline{PDPINTx}$ is taken high depends on the state of the FCOMPOE bit.

Figure 6-22. External Interrupt Timing

6.18 General-Purpose Input/Output (GPIO) – Output Timing

Table 6-24. General-Purpose Output Switching Characteristics

| PARAMETER | | | MIN | MAX | UNIT |
|-------------------|---|-----------|-----|---------------|-------|
| $t_{d(XCOH-GPO)}$ | Delay time, XCLKOUT high to GPIO low/high | All GPIOs | | $1t_{c(SCO)}$ | cycle |
| $t_{r(GPO)}$ | Rise time, GPIO switching low to high | All GPIOs | | 10 | ns |
| $t_{f(GPO)}$ | Fall time, GPIO switching high to low | All GPIOs | | 10 | ns |
| f_{GPO} | Toggleing frequency, GPO pins | | | 20 | MHz |

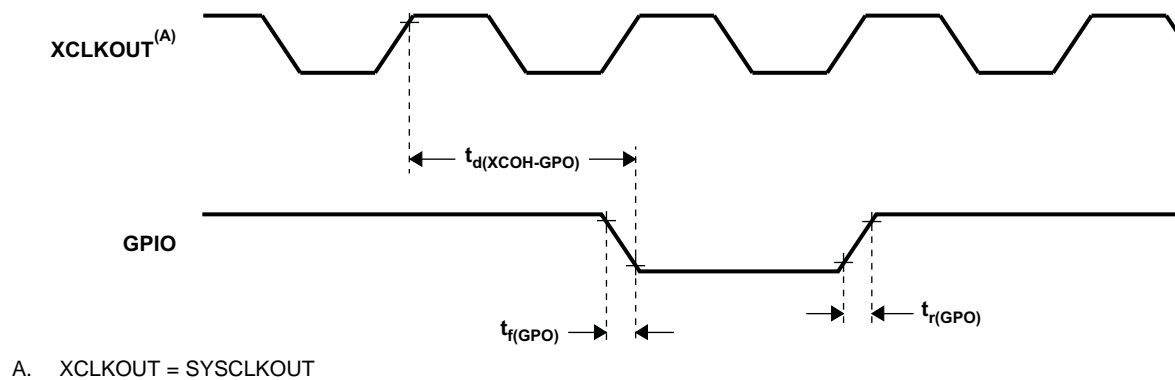
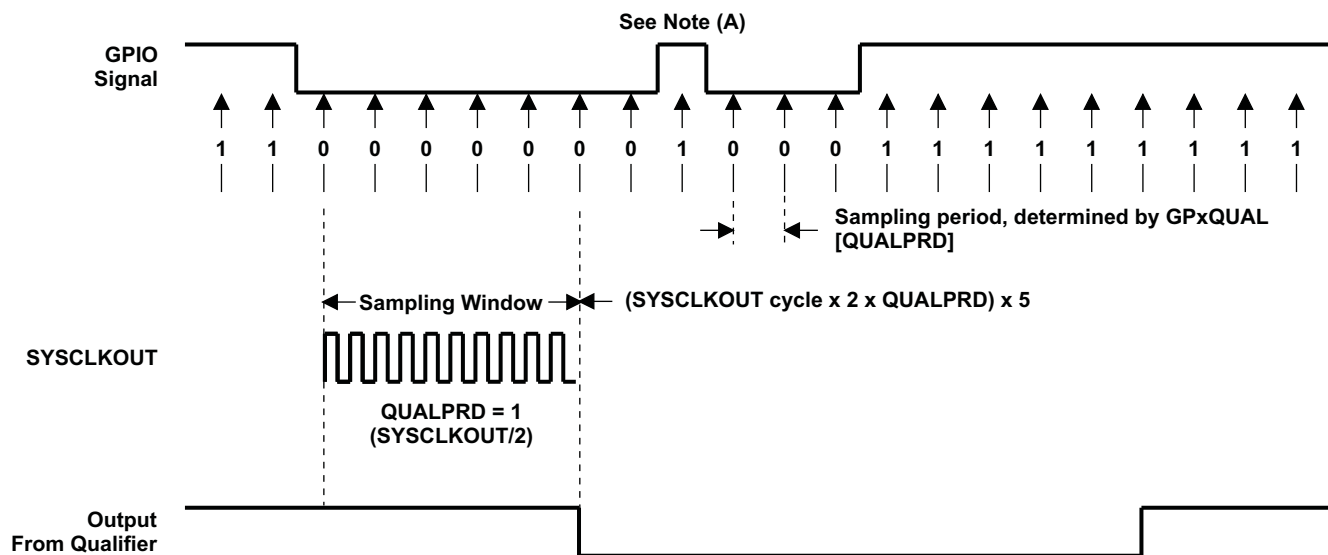

Figure 6-23. General-Purpose Output Timing

6.19 General-Purpose Input/Output (GPIO) – Input Timing



- A. This glitch is ignored by the input qualifier. The QUALPRD bit field specifies the qualification sampling period. It can vary from 00 to 0xFF. Input qualification is not applicable when QUALPRD = 00. For any other value "n", the qualification sampling period is 2n SYSCLKOUT cycles (that is, at every 2n SYSCLKOUT cycle, the GPIO pin will be sampled). Six consecutive samples must be of the same value for a given input to be recognized.
- B. For the qualifier to detect the change, the input must be stable for 10 SYSCLKOUT cycles or greater. In other words, the inputs should be stable for $(5 \times \text{QUALPRD} \times 2)$ SYSCLKOUT cycles. This would enable five sampling periods for detection to occur. Since external signals are driven asynchronously, a 13-SYSCLKOUT-wide pulse provides reliable recognition.

Figure 6-24. GPIO Input Qualifier – Example Diagram for QUALPRD = 1

Table 6-25. General-Purpose Input Timing Requirements

| | | | MIN | MAX | UNIT |
|--------------|------------------------------|-----------|---------------------------|-----|--------|
| $t_{w(GPI)}$ | Pulse duration GPIO low/high | All GPIOs | With no qualifier | | cycles |
| | | | With qualifier | | |
| | | | $2t_{c(SCO)}$ | | |
| | | | $1t_{c(SCO)} + IQT^{(1)}$ | | |

(1) Input Qualification Time (IQT) = $[t_{c(SCO)} \times 2 \times QUALPRD] \times 5 + [t_{c(SCO)} \times 2 \times QUALPRD]$.

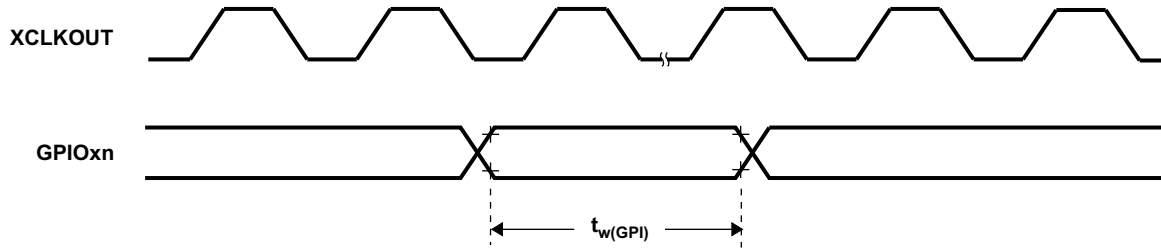

Figure 6-25. General-Purpose Input Timing

NOTE

The pulse width requirement for general-purpose input is applicable for the \overline{XBIO} and ADCSOC pins as well.

6.20 Serial Peripheral Interface (SPI) Master Mode Timing

Table 6-26 lists the master mode timing (clock phase = 0) and Table 6-27 lists the timing (clock phase = 1). Figure 6-26 and Figure 6-27 show the timing waveforms.

Table 6-26. SPI Master Mode External Timing (Clock Phase = 0)⁽¹⁾⁽²⁾

| NO. | | | SPI WHEN (SPIBRR + 1) IS EVEN OR SPIBRR = 0 OR 2 | | SPI WHEN (SPIBRR + 1) IS ODD AND SPIBRR > 3 | | UNIT |
|------------------|----------------------|---|--|------------------|---|----------------------------------|------|
| | | | MIN | MAX | MIN | MAX | |
| 1 | $t_{c(SPC)M}$ | Cycle time, SPICLK | $4t_{c(LCO)}$ | $128t_{c(LCO)}$ | $5t_{c(LCO)}$ | $127t_{c(LCO)}$ | ns |
| 2 ⁽³⁾ | $t_{w(SPCH)M}$ | Pulse duration, SPICLK high (clock polarity = 0) | $0.5t_{c(SPC)M} - 10$ | $0.5t_{c(SPC)M}$ | $0.5t_{c(SPC)M} - 0.5t_{c(LCO)} - 10$ | $0.5t_{c(SPC)M} - 0.5t_{c(LCO)}$ | ns |
| | $t_{w(SPCL)M}$ | Pulse duration, SPICLK low (clock polarity = 1) | $0.5t_{c(SPC)M} - 10$ | $0.5t_{c(SPC)M}$ | $0.5t_{c(SPC)M} - 0.5t_{c(LCO)} - 10$ | $0.5t_{c(SPC)M} - 0.5t_{c(LCO)}$ | |
| 3 ⁽³⁾ | $t_{w(SPCL)M}$ | Pulse duration, SPICLK low (clock polarity = 0) | $0.5t_{c(SPC)M} - 10$ | $0.5t_{c(SPC)M}$ | $0.5t_{c(SPC)M} + 0.5t_{c(LCO)} - 10$ | $0.5t_{c(SPC)M} + 0.5t_{c(LCO)}$ | ns |
| | $t_{w(SPCH)M}$ | Pulse duration, SPICLK high (clock polarity = 1) | $0.5t_{c(SPC)M} - 10$ | $0.5t_{c(SPC)M}$ | $0.5t_{c(SPC)M} + 0.5t_{c(LCO)} - 10$ | $0.5t_{c(SPC)M} + 0.5t_{c(LCO)}$ | |
| 4 ⁽³⁾ | $t_{d(SPCH-SIMO)M}$ | Delay time, SPICLK high to SPISIMO valid (clock polarity = 0) | -10 | 10 | -10 | 10 | ns |
| | $t_{d(SPCL-SIMO)M}$ | Delay time, SPICLK low to SPISIMO valid (clock polarity = 1) | -10 | 10 | -10 | 10 | |
| 5 ⁽³⁾ | $t_{v(SPCL-SIMO)M}$ | Valid time, SPISIMO data valid after SPICLK low (clock polarity = 0) | $0.5t_{c(SPC)M} - 10$ | | $0.5t_{c(SPC)M} + 0.5t_{c(LCO)} - 10$ | | ns |
| | $t_{v(SPCH-SIMO)M}$ | Valid time, SPISIMO data valid after SPICLK high (clock polarity = 1) | $0.5t_{c(SPC)M} - 10$ | | $0.5t_{c(SPC)M} + 0.5t_{c(LCO)} - 10$ | | |
| 8 ⁽³⁾ | $t_{su(SOMI-SPCL)M}$ | Setup time, SPISOMI before SPICLK low (clock polarity = 0) | 0 | | 0 | | ns |
| | $t_{su(SOMI-SPCH)M}$ | Setup time, SPISOMI before SPICLK high (clock polarity = 1) | 0 | | 0 | | |
| 9 ⁽³⁾ | $t_{v(SPCL-SOMI)M}$ | Valid time, SPISOMI data valid after SPICLK low (clock polarity = 0) | $0.25t_{c(SPC)M} - 10$ | | $0.5t_{c(SPC)M} - 0.5t_{c(LCO)} - 10$ | | ns |
| | $t_{v(SPCH-SOMI)M}$ | Valid time, SPISOMI data valid after SPICLK high (clock polarity = 1) | $0.25t_{c(SPC)M} - 10$ | | $0.5t_{c(SPC)M} - 0.5t_{c(LCO)} - 10$ | | |

(1) The MASTER/SLAVE bit (SPICTL.2) is set and the CLOCK PHASE bit (SPICTL.3) is cleared.

(2) $t_{c(SPC)}$ = SPI clock cycle time = LSPCLK/4 or LSPCLK/(SPIBRR + 1)

$t_{c(LCO)}$ = LSPCLK cycle time

(3) The active edge of the SPICLK signal referenced is controlled by the CLOCK POLARITY bit (SPICCR.6).

NOTE: Internal clock prescalers must be adjusted such that the SPI clock speed is limited to the following SPI clock rate:

- Master mode transmit: 20 MHz MAX. Master mode receive: 12.5 MHz MAX.
- Slave mode transmit: 12.5 MHz MAX. Slave mode receive: 12.5 MHz MAX.

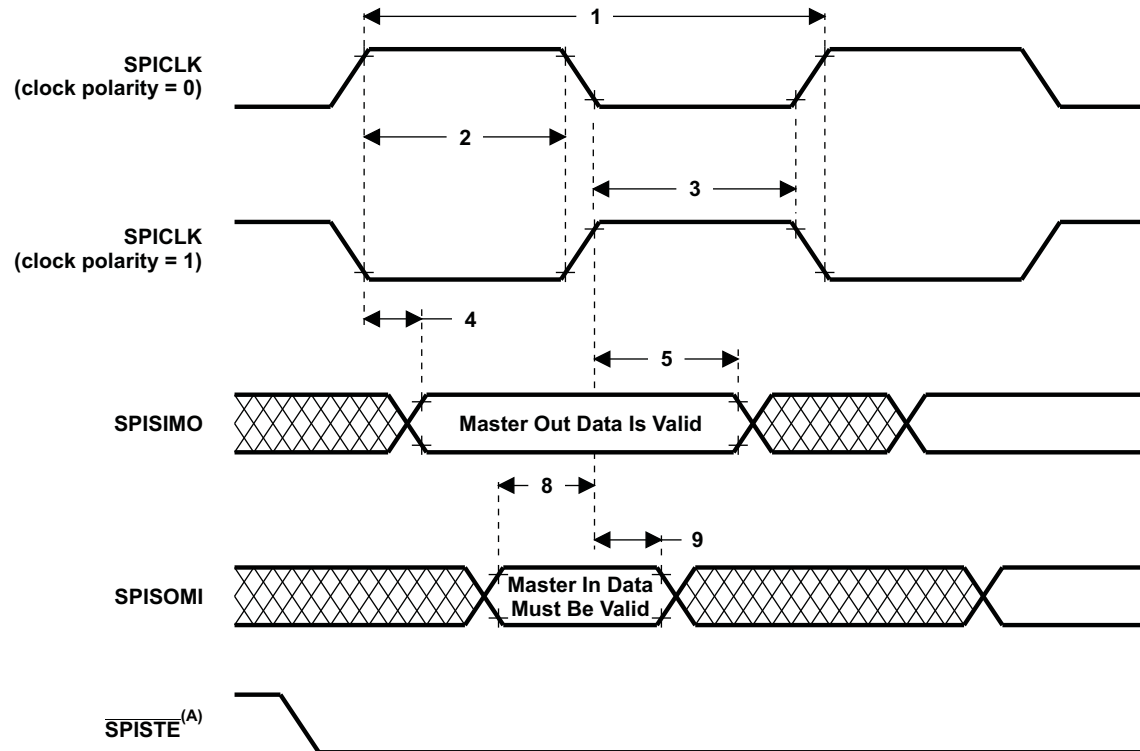

- A. In the master mode, $\overline{\text{SPISIMO}}$ goes active $0.5t_{c(\text{SPICLK})}$ before valid SPI clock edge. On the trailing end of the word, the $\overline{\text{SPISIMO}}$ will go inactive $0.5t_{c(\text{SPICLK})}$ after the receiving edge (SPICLK) of the last data bit, except that $\overline{\text{SPISIMO}}$ stays active between back-to-back transmit words in both FIFO and non-FIFO modes.

Figure 6-26. SPI Master Mode External Timing (Clock Phase = 0)

Table 6-27. SPI Master Mode External Timing (Clock Phase = 1)⁽¹⁾⁽²⁾

| NO. | | | SPI WHEN (SPIBRR + 1) IS EVEN OR SPIBRR = 0 OR 2 | | SPI WHEN (SPIBRR + 1) IS ODD AND SPIBRR > 3 | | UNIT |
|-------------------|----------------------|--|---|------------------|--|----------------------------------|------|
| | | | MIN | MAX | MIN | MAX | |
| 1 | $t_{c(SPC)M}$ | Cycle time, SPICLK | $4t_{c(LCO)}$ | $128t_{c(LCO)}$ | $5t_{c(LCO)}$ | $127t_{c(LCO)}$ | ns |
| 2 ⁽³⁾ | $t_{w(SPCH)M}$ | Pulse duration, SPICLK high (clock polarity = 0) | $0.5t_{c(SPC)M} - 10$ | $0.5t_{c(SPC)M}$ | $0.5t_{c(SPC)M} - 0.5t_{c(LCO)} - 10$ | $0.5t_{c(SPC)M} - 0.5t_{c(LCO)}$ | ns |
| | $t_{w(SPCL)M}$ | Pulse duration, SPICLK low (clock polarity = 1) | $0.5t_{c(SPC)M} - 10$ | $0.5t_{c(SPC)M}$ | $0.5t_{c(SPC)M} - 0.5t_{c(LCO)} - 10$ | $0.5t_{c(SPC)M} - 0.5t_{c(LCO)}$ | |
| 3 ⁽³⁾ | $t_{w(SPCL)M}$ | Pulse duration, SPICLK low (clock polarity = 0) | $0.5t_{c(SPC)M} - 10$ | $0.5t_{c(SPC)M}$ | $0.5t_{c(SPC)M} + 0.5t_{c(LCO)} - 10$ | $0.5t_{c(SPC)M} + 0.5t_{c(LCO)}$ | ns |
| | $t_{w(SPCH)M}$ | Pulse duration, SPICLK high (clock polarity = 1) | $0.5t_{c(SPC)M} - 10$ | $0.5t_{c(SPC)M}$ | $0.5t_{c(SPC)M} + 0.5t_{c(LCO)} - 10$ | $0.5t_{c(SPC)M} + 0.5t_{c(LCO)}$ | |
| 6 ⁽³⁾ | $t_{su(SIMO-SPCH)M}$ | Setup time, SPISIMO data valid before SPICLK high (clock polarity = 0) | $0.5t_{c(SPC)M} - 10$ | | $0.5t_{c(SPC)M} - 10$ | | ns |
| | $t_{su(SIMO-SPCL)M}$ | Setup time, SPISIMO data valid before SPICLK low (clock polarity = 1) | $0.5t_{c(SPC)M} - 10$ | | $0.5t_{c(SPC)M} - 10$ | | |
| 7 ⁽³⁾ | $t_{v(SPCH-SIMO)M}$ | Valid time, SPISIMO data valid after SPICLK high (clock polarity = 0) | $0.5t_{c(SPC)M} - 10$ | | $0.5t_{c(SPC)M} - 10$ | | ns |
| | $t_{v(SPCL-SIMO)M}$ | Valid time, SPISIMO data valid after SPICLK low (clock polarity = 1) | $0.5t_{c(SPC)M} - 10$ | | $0.5t_{c(SPC)M} - 10$ | | |
| 10 ⁽³⁾ | $t_{su(SOMI-SPCH)M}$ | Setup time, SPISOMI before SPICLK high (clock polarity = 0) | 0 | | 0 | | ns |
| | $t_{su(SOMI-SPCL)M}$ | Setup time, SPISOMI before SPICLK low (clock polarity = 1) | 0 | | 0 | | |
| 11 ⁽³⁾ | $t_{v(SPCH-SOMI)M}$ | Valid time, SPISOMI data valid after SPICLK high (clock polarity = 0) | $0.25t_{c(SPC)M} - 10$ | | $0.5t_{c(SPC)M} - 10$ | | ns |
| | $t_{v(SPCL-SOMI)M}$ | Valid time, SPISOMI data valid after SPICLK low (clock polarity = 1) | $0.25t_{c(SPC)M} - 10$ | | $0.5t_{c(SPC)M} - 10$ | | |

(1) The MASTER/SLAVE bit (SPICTL.2) is set and the CLOCK PHASE bit (SPICTL.3) is set.

(2) $t_{c(SPC)}$ = SPI clock cycle time = LSPCLK/4 or LSPCLK/(SPIBRR + 1)

$t_{c(LCO)}$ = LSPCLK cycle time

(3) The active edge of the SPICLK signal referenced is controlled by the CLOCK POLARITY bit (SPICCR.6).

NOTE: Internal clock prescalers must be adjusted such that the SPI clock speed is limited to the following SPI clock rate:

- Master mode transmit: 20 MHz MAX. Master mode receive: 12.5 MHz MAX.
- Slave mode transmit: 12.5 MHz MAX. Slave mode receive: 12.5 MHz MAX.

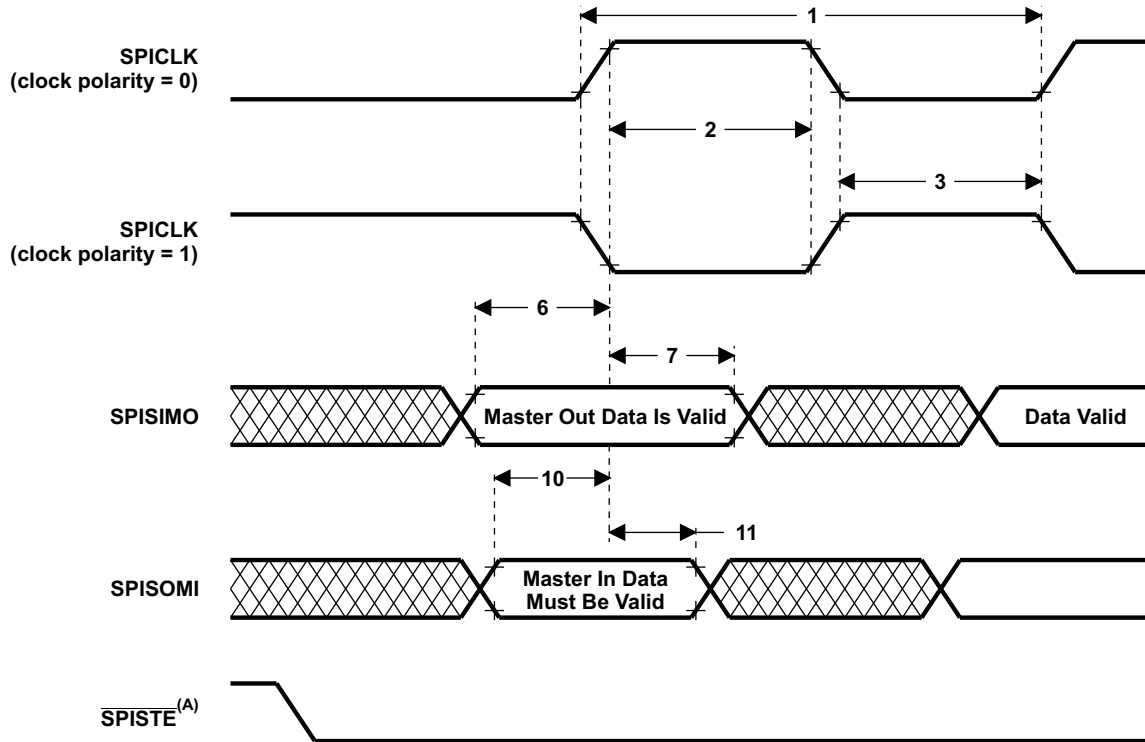

- A. In the master mode, $\overline{\text{SPISTE}}$ goes active $0.5t_{c(\text{SPC})}$ before valid SPI clock edge. On the trailing end of the word, the $\overline{\text{SPISTE}}$ will go inactive $0.5t_{c(\text{SPC})}$ after the receiving edge (SPICLK) of the last data bit, except that $\overline{\text{SPISTE}}$ stays active between back-to-back transmit words in both FIFO and non-FIFO modes.

Figure 6-27. SPI Master External Timing (Clock Phase = 1)

6.21 Serial Peripheral Interface (SPI) Slave Mode Timing

Table 6-28 lists the slave mode timing (clock phase = 0) and Table 6-29 lists the timing (clock phase = 1). Figure 6-28 and Figure 6-29 show the timing waveforms.

Table 6-28. SPI Slave Mode External Timing (Clock Phase = 0)⁽¹⁾⁽²⁾

| NO. | | | MIN | MAX | UNIT |
|-------------------|----------------------|---|-------------------------|------------------|------|
| 12 | $t_{c(SPC)S}$ | Cycle time, SPICLK | $4t_{c(LCO)}$ | | ns |
| 13 ⁽³⁾ | $t_{w(SPCH)S}$ | Pulse duration, SPICLK high (clock polarity = 0) | $0.5t_{c(SPC)S} - 10$ | $0.5t_{c(SPC)S}$ | ns |
| | $t_{w(SPCL)S}$ | Pulse duration, SPICLK low (clock polarity = 1) | $0.5t_{c(SPC)S} - 10$ | $0.5t_{c(SPC)S}$ | |
| 14 ⁽³⁾ | $t_{w(SPCL)S}$ | Pulse duration, SPICLK low (clock polarity = 0) | $0.5t_{c(SPC)S} - 10$ | $0.5t_{c(SPC)S}$ | ns |
| | $t_{w(SPCH)S}$ | Pulse duration, SPICLK high (clock polarity = 1) | $0.5t_{c(SPC)S} - 10$ | $0.5t_{c(SPC)S}$ | |
| 15 ⁽³⁾ | $t_{d(SPCH-SOM)S}$ | Delay time, SPICLK high to SPISOMI valid (clock polarity = 0) | $0.375t_{c(SPC)S} - 10$ | | ns |
| | $t_{d(SPCL-SOM)S}$ | Delay time, SPICLK low to SPISOMI valid (clock polarity = 1) | $0.375t_{c(SPC)S} - 10$ | | |
| 16 ⁽³⁾ | $t_{v(SPCL-SOM)S}$ | Valid time, SPISOMI data valid after SPICLK low (clock polarity = 0) | $0.75t_{c(SPC)S}$ | | ns |
| | $t_{v(SPCH-SOM)S}$ | Valid time, SPISOMI data valid after SPICLK high (clock polarity = 1) | $0.75t_{c(SPC)S}$ | | |
| 19 ⁽³⁾ | $t_{su(SIMO-SPCL)S}$ | Setup time, SPISIMO before SPICLK low (clock polarity = 0) | 0 | | ns |
| | $t_{su(SIMO-SPCH)S}$ | Setup time, SPISIMO before SPICLK high (clock polarity = 1) | 0 | | |
| 20 ⁽³⁾ | $t_{v(SPCL-SIMO)S}$ | Valid time, SPISIMO data valid after SPICLK low (clock polarity = 0) | $0.5t_{c(SPC)S}$ | | ns |
| | $t_{v(SPCH-SIMO)S}$ | Valid time, SPISIMO data valid after SPICLK high (clock polarity = 1) | $0.5t_{c(SPC)S}$ | | |

(1) The MASTER/SLAVE bit (SPICL2) is cleared and the CLOCK PHASE bit (SPICL3) is cleared.

(2) $t_{c(SPC)}$ = SPI clock cycle time = LSPCLK/4 or LSPCLK/(SPIBRR + 1)

$t_{c(LCO)}$ = LSPCLK cycle time

(3) The active edge of the SPICLK signal referenced is controlled by the CLOCK POLARITY bit (SPICCR.6).

NOTE: Internal clock prescalers must be adjusted such that the SPI clock speed is limited to the following SPI clock rate:

- Master mode transmit: 20 MHz MAX. Master mode receive: 12.5 MHz MAX.
- Slave mode transmit: 12.5 MHz MAX. Slave mode receive: 12.5 MHz MAX.

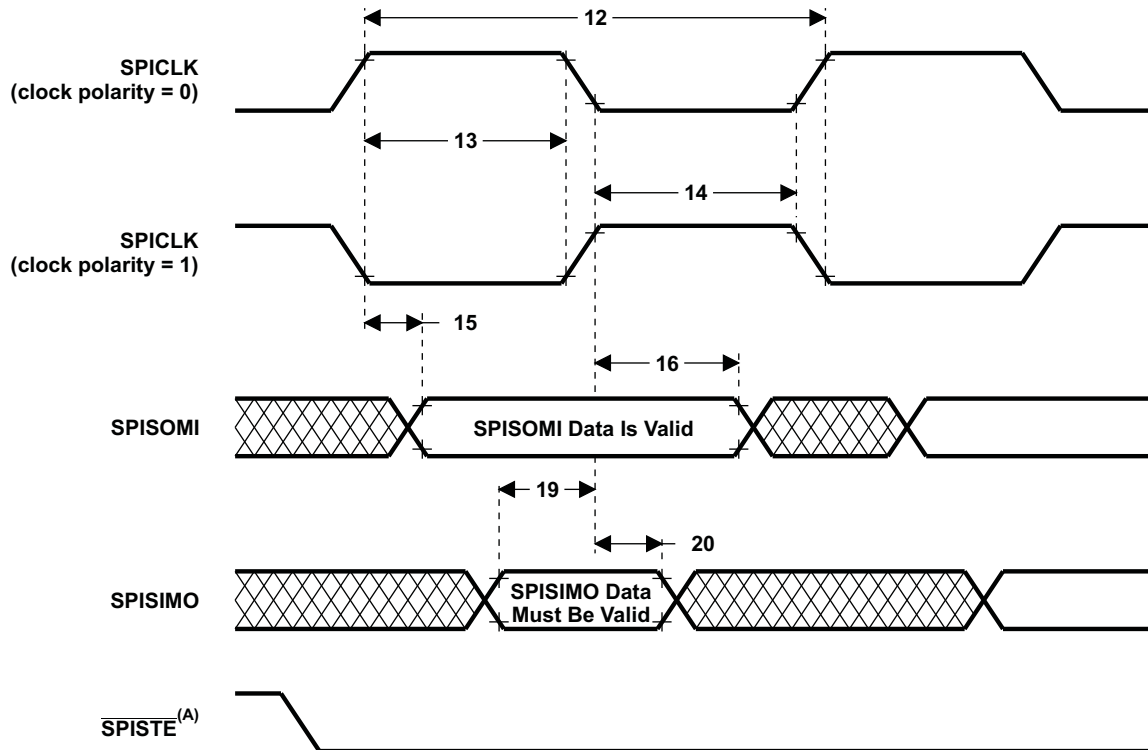

- A. In the slave mode, the $\overline{\text{SPISTE}}$ signal should be asserted low at least $0.5t_{\text{C(SPC)}}$ before the valid SPI clock edge and remain low for at least $0.5t_{\text{C(SPC)}}$ after the receiving edge (SPICLK) of the last data bit.

Figure 6-28. SPI Slave Mode External Timing (Clock Phase = 0)

Table 6-29. SPI Slave Mode External Timing (Clock Phase = 1)⁽¹⁾⁽²⁾

| NO. | | | MIN | MAX | UNIT |
|-------------------|----------------------|---|-----------------------|------------------|------|
| 12 | $t_{c(SPC)S}$ | Cycle time, SPICLK | $8t_{c(LCO)}$ | | ns |
| 13 ⁽³⁾ | $t_{w(SPCH)S}$ | Pulse duration, SPICLK high (clock polarity = 0) | $0.5t_{c(SPC)S} - 10$ | $0.5t_{c(SPC)S}$ | ns |
| | $t_{w(SPCL)S}$ | Pulse duration, SPICLK low (clock polarity = 1) | $0.5t_{c(SPC)S} - 10$ | $0.5t_{c(SPC)S}$ | |
| 14 ⁽³⁾ | $t_{w(SPCL)S}$ | Pulse duration, SPICLK low (clock polarity = 0) | $0.5t_{c(SPC)S} - 10$ | $0.5t_{c(SPC)S}$ | ns |
| | $t_{w(SPCH)S}$ | Pulse duration, SPICLK high (clock polarity = 1) | $0.5t_{c(SPC)S} - 10$ | $0.5t_{c(SPC)S}$ | |
| 17 ⁽³⁾ | $t_{su(SOMI-SPCH)S}$ | Setup time, SPISOMI before SPICLK high (clock polarity = 0) | $0.125t_{c(SPC)S}$ | | ns |
| | $t_{su(SOMI-SPCL)S}$ | Setup time, SPISOMI before SPICLK low (clock polarity = 1) | $0.125t_{c(SPC)S}$ | | |
| 18 ⁽³⁾ | $t_{v(SPCH-SOMI)S}$ | Valid time, SPISOMI data valid after SPICLK high (clock polarity = 0) | $0.75t_{c(SPC)S}$ | | ns |
| | $t_{v(SPCL-SOMI)S}$ | Valid time, SPISOMI data valid after SPICLK low (clock polarity = 1) | $0.75t_{c(SPC)S}$ | | |
| 21 ⁽³⁾ | $t_{su(SIMO-SPCH)S}$ | Setup time, SPISIMO before SPICLK high (clock polarity = 0) | 0 | | ns |
| | $t_{su(SIMO-SPCL)S}$ | Setup time, SPISIMO before SPICLK low (clock polarity = 1) | 0 | | |
| 22 ⁽³⁾ | $t_{v(SPCH-SIMO)S}$ | Valid time, SPISIMO data valid after SPICLK high (clock polarity = 0) | $0.5t_{c(SPC)S}$ | | ns |
| | $t_{v(SPCL-SIMO)S}$ | Valid time, SPISIMO data valid after SPICLK low (clock polarity = 1) | $0.5t_{c(SPC)S}$ | | |

(1) The MASTER/SLAVE bit (SPICTL.2) is cleared and the CLOCK PHASE bit (SPICTL.3) is set.

(2) $t_{c(SPC)}$ = SPI clock cycle time = LSPCLK/4 or LSPCLK/(SPIBRR + 1)

$t_{c(LCO)}$ = LSPCLK cycle time

(3) The active edge of the SPICLK signal referenced is controlled by the CLOCK POLARITY bit (SPICCR.6).

NOTE: Internal clock prescalers must be adjusted such that the SPI clock speed is limited to the following SPI clock rate:

- Master mode transmit: 20 MHz MAX. Master mode receive: 12.5 MHz MAX.
- Slave mode transmit: 12.5 MHz MAX. Slave mode receive: 12.5 MHz MAX.

6.22 External Interface (XINTF) Timing

Each XINTF access consists of three parts: Lead, Active, and Trail. The user configures the Lead/Active/Trail wait states in the XTIMING registers. There is one XTIMING register for each XINTF zone. Table 6-30 shows the relationship between the parameters configured in the XTIMING register and the duration of the pulse in terms of XTIMCLK cycles.

Table 6-30. Relationship Between Parameters Configured in XTIMING and Duration of Pulse⁽¹⁾⁽²⁾

| DESCRIPTION | DURATION (ns) | |
|--------------------------------|---|--|
| | X2TIMING = 0 | X2TIMING = 1 |
| LR Lead period, read access | $XRDLEAD \times t_{c(XTIM)}$ | $(XRDLEAD \times 2) \times t_{c(XTIM)}$ |
| AR Active period, read access | $(XRDACTIVE + WS + 1) \times t_{c(XTIM)}$ | $(XRDACTIVE \times 2 + WS + 1) \times t_{c(XTIM)}$ |
| TR Trail period, read access | $XRDTRAIL \times t_{c(XTIM)}$ | $(XRDTRAIL \times 2) \times t_{c(XTIM)}$ |
| LW Lead period, write access | $XWRLEAD \times t_{c(XTIM)}$ | $(XWRLEAD \times 2) \times t_{c(XTIM)}$ |
| AW Active period, write access | $(XWRACTIVE + WS + 1) \times t_{c(XTIM)}$ | $(XWRACTIVE \times 2 + WS + 1) \times t_{c(XTIM)}$ |
| TW Trail period, write access | $XWRTRAIL \times t_{c(XTIM)}$ | $(XWRTRAIL \times 2) \times t_{c(XTIM)}$ |

(1) $t_{c(XTIM)}$ – Cycle time, XTIMCLK

(2) WS refers to the number of wait states inserted by hardware when using XREADY. If the zone is configured to ignore XREADY (USEREADY = 0), then WS = 0.

Minimum wait state requirements must be met when configuring each zone's XTIMING register. These requirements are in addition to any timing requirements as specified by that device's data sheet. No internal device hardware is included to detect illegal settings.

- If the XREADY signal is ignored (USEREADY = 0), then:

- Lead: $LR \geq t_{c(XTIM)}$
 $LW \geq t_{c(XTIM)}$

These requirements result in the following XTIMING register configuration restrictions (no hardware to detect illegal XTIMING configurations):

| XRDLEAD | XRDACTIVE | XRDTRAIL | XWRLEAD | XWRACTIVE | XWRTRAIL | X2TIMING |
|----------|-----------|----------|----------|-----------|----------|----------|
| ≥ 1 | ≥ 0 | ≥ 0 | ≥ 1 | ≥ 0 | ≥ 0 | 0, 1 |

Examples of valid and invalid timing when not sampling XREADY (no hardware to detect illegal XTIMING configurations):

| | XRDLEAD | XRDACTIVE | XRDTRAIL | XWRLEAD | XWRACTIVE | XWRTRAIL | X2TIMING |
|---------|---------|-----------|----------|---------|-----------|----------|----------|
| Invalid | 0 | 0 | 0 | 0 | 0 | 0 | 0, 1 |
| Valid | 1 | 0 | 0 | 1 | 0 | 0 | 0, 1 |

- If the XREADY signal is sampled in the synchronous mode (USEREADY = 1, READYMODE = 0), then:
 1. Lead:
 - LR $\geq t_{c(XTIM)}$
 - LW $\geq t_{c(XTIM)}$
 2. Active:
 - AR $\geq 2 \times t_{c(XTIM)}$
 - AW $\geq 2 \times t_{c(XTIM)}$

NOTE: Restriction does not include external hardware wait states.

These requirements result in the following XTIMING register configuration restrictions (no hardware to detect illegal XTIMING configurations):

| XRDLEAD | XRDACTIVE | XRDTRAIL | XWRLEAD | XWRACTIVE | XWRTRAIL | X2TIMING |
|----------|-----------|----------|----------|-----------|----------|----------|
| ≥ 1 | ≥ 1 | ≥ 0 | ≥ 1 | ≥ 1 | ≥ 0 | 0, 1 |

Examples of valid and invalid timing when using synchronous XREADY (no hardware to detect illegal XTIMING configurations):

| | XRDLEAD | XRDACTIVE | XRDTRAIL | XWRLEAD | XWRACTIVE | XWRTRAIL | X2TIMING |
|---------|---------|-----------|----------|---------|-----------|----------|----------|
| Invalid | 0 | 0 | 0 | 0 | 0 | 0 | 0, 1 |
| Invalid | 1 | 0 | 0 | 1 | 0 | 0 | 0, 1 |
| Valid | 1 | 1 | 0 | 1 | 1 | 0 | 0, 1 |

- If the XREADY signal is sampled in the asynchronous mode (USEREADY = 1, READYMODE = 1), then:
 1. Lead: $LR \geq t_{c(XTIM)}$
 $LW \geq t_{c(XTIM)}$
 2. Active: $AR \geq 2 \times t_{c(XTIM)}$
 $AW \geq 2 \times t_{c(XTIM)}$

NOTE: Restriction does not include external hardware wait states

 3. Lead + Active: $LR + AR \geq 4 \times t_{c(XTIM)}$
 $LW + AW \geq 4 \times t_{c(XTIM)}$

NOTE: Restriction does not include external hardware wait states

These requirements result in the following XTIMING register configuration restrictions (no hardware to detect illegal XTIMING configurations):

| XRDLEAD | XRDACTIVE | XRDTRAIL | XWRLEAD | XWRACTIVE | XWRTRAIL | X2TIMING |
|----------|-----------|----------|----------|-----------|----------|----------|
| ≥ 1 | ≥ 2 | 0 | ≥ 1 | ≥ 2 | 0 | 0, 1 |

or (no hardware to detect illegal XTIMING configurations):

| XRDLEAD | XRDACTIVE | XRDTRAIL | XWRLEAD | XWRACTIVE | XWRTRAIL | X2TIMING |
|----------|-----------|----------|----------|-----------|----------|----------|
| ≥ 2 | ≥ 1 | 0 | ≥ 2 | ≥ 1 | 0 | 0, 1 |

Examples of valid and invalid timing when using asynchronous XREADY (no hardware to detect illegal XTIMING configurations):

| | XRDLEAD | XRDACTIVE | XRDTRAIL | XWRLEAD | XWRACTIVE | XWRTRAIL | X2TIMING |
|---------|---------|-----------|----------|---------|-----------|----------|----------|
| Invalid | 0 | 0 | 0 | 0 | 0 | 0 | 0, 1 |
| Invalid | 1 | 0 | 0 | 1 | 0 | 0 | 0, 1 |
| Invalid | 1 | 1 | 0 | 1 | 1 | 0 | 0 |
| Valid | 1 | 1 | 0 | 1 | 1 | 0 | 1 |
| Valid | 1 | 2 | 0 | 1 | 2 | 0 | 0, 1 |
| Valid | 2 | 1 | 0 | 2 | 1 | 0 | 0, 1 |

Unless otherwise specified, all XINTF timing is applicable for the clock configurations shown in [Table 6-31](#).

Table 6-31. XINTF Clock Configurations

| MODE | SYCLKOUT | XTIMCLK | XCLKOUT |
|---------------|----------|------------------------|--------------------------|
| 1 Example: | 150 MHz | SYCLKOUT 150 MHz | SYCLKOUT 150 MHz |
| 2 Example: | 150 MHz | SYCLKOUT 150 MHz | 1/2 SYCLKOUT 75 MHz |
| 3 Example: | 150 MHz | 1/2 SYCLKOUT 75 MHz | 1/2 SYCLKOUT 75 MHz |
| 4 Example: | 150 MHz | 1/2 SYCLKOUT 75 MHz | 1/4 SYCLKOUT 37.5 MHz |

The relationship between SYCLKOUT and XTIMCLK is shown in [Figure 6-30](#).

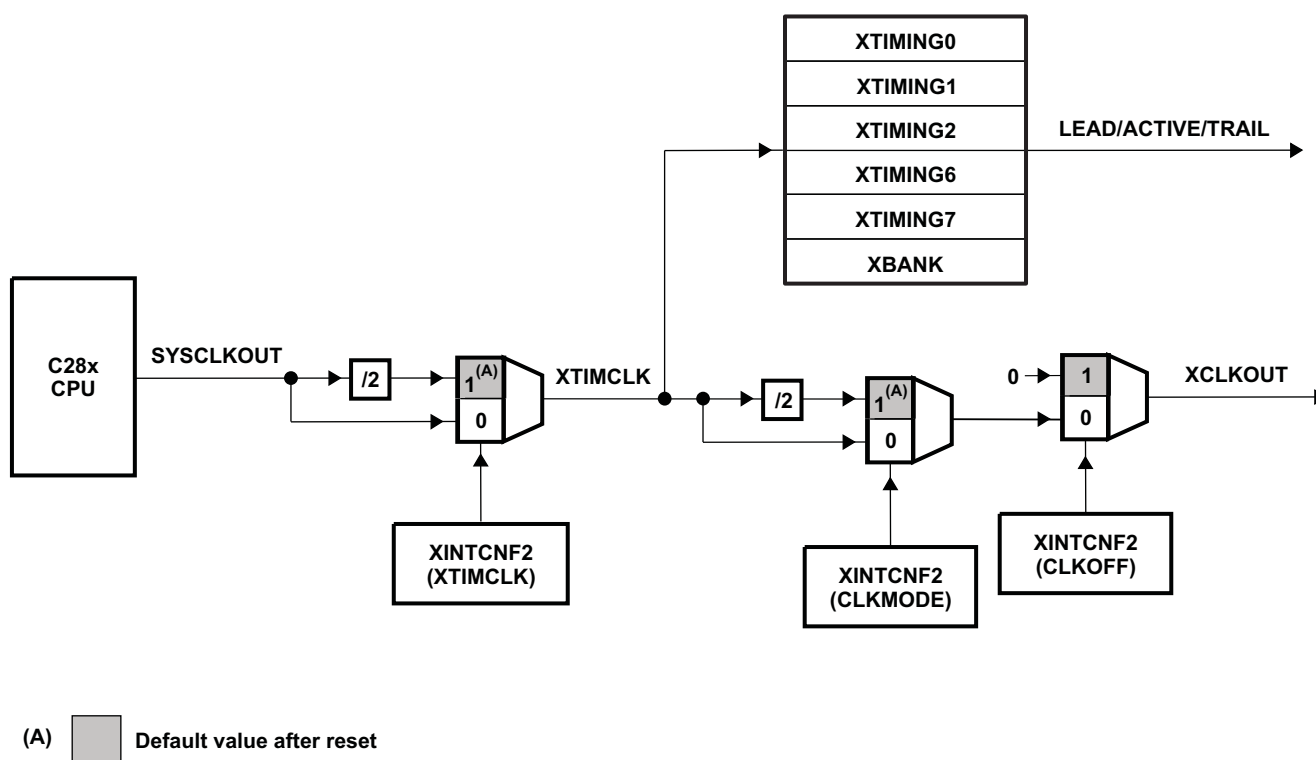

Figure 6-30. Relationship Between XTIMCLK and SYCLKOUT

6.23 XINTF Signal Alignment to XCLKOUT

For each XINTF access, the number of lead, active, and trail cycles is based on the internal clock XTIMCLK. Strobes such as $\overline{\text{XR}}\overline{\text{D}}$, $\overline{\text{XW}}\overline{\text{E}}$, and zone chip-select ($\overline{\text{XZCS}}$) change state in relationship to the rising edge of XTIMCLK. The external clock, XCLKOUT, can be configured to be either equal to or one-half the frequency of XTIMCLK.

For the case where XCLKOUT = XTIMCLK, all of the XINTF strobes will change state with respect to the rising edge of XCLKOUT. For the case where XCLKOUT = one-half XTIMCLK, some strobes will change state either on the rising edge of XCLKOUT or the falling edge of XCLKOUT. In the XINTF timing tables, the notation XCOHL is used to indicate that the parameter is with respect to either case; XCLKOUT rising edge (high) or XCLKOUT falling edge (low). If the parameter is always with respect to the rising edge of XCLKOUT, the notation XCOH is used.

For the case where XCLKOUT = one-half XTIMCLK, the XCLKOUT edge with which the change will be aligned can be determined based on the number of XTIMCLK cycles from the start of the access to the point at which the signal changes. If this number of XTIMCLK cycles is even, the alignment will be with respect to the rising edge of XCLKOUT. If this number is odd, then the signal will change with respect to the falling edge of XCLKOUT. Examples include the following:

- Strobes that change at the beginning of an access always align to the rising edge of XCLKOUT. This is because all XINTF accesses begin with respect to the rising edge of XCLKOUT.

Examples: XZCSL Zone chip-select active-low
 XRNWL $\overline{\text{XR}}\overline{\text{W}}$ active-low

- Strobes that change at the beginning of the active period will align to the rising edge of XCLKOUT if the total number of lead XTIMCLK cycles for the access is even. If the number of lead XTIMCLK cycles is odd, then the alignment will be with respect to the falling edge of XCLKOUT.

Examples: XRDL $\overline{\text{XR}}\overline{\text{D}}$ active-low
 XWEL $\overline{\text{XW}}\overline{\text{E}}$ active-low

- Strobes that change at the beginning of the trail period will align to the rising edge of XCLKOUT if the total number of lead + active XTIMCLK cycles (including hardware waitstates) for the access is even. If the number of lead + active XTIMCLK cycles (including hardware waitstates) is odd, then the alignment will be with respect to the falling edge of XCLKOUT.

Examples: XRDH $\overline{\text{XR}}\overline{\text{D}}$ inactive-high
 XWEH $\overline{\text{XW}}\overline{\text{E}}$ inactive-high

- Strobes that change at the end of the access will align to the rising edge of XCLKOUT if the total number of lead + active + trail XTIMCLK cycles (including hardware waitstates) is even. If the number of lead + active + trail XTIMCLK cycles (including hardware waitstates) is odd, then the alignment will be with respect to the falling edge of XCLKOUT.

Examples: XZCSH Zone chip-select inactive-high
 XRNWH $\overline{\text{XR}}\overline{\text{W}}$ inactive-high

6.24 External Interface Read Timing

Table 6-32. External Memory Interface Read Switching Characteristics

| PARAMETER | | MIN | MAX | UNIT |
|---------------------------|---|-----|-----|------|
| $t_{d(XCOH-XZCSL)}$ | Delay time, XCLKOUT high to zone chip-select active-low | | 1 | ns |
| $t_{d(XCOHL-XZCSH)}$ | Delay time, XCLKOUT high/low to zone chip-select inactive-high | -2 | 3 | ns |
| $t_{d(XCOH-XA)}$ | Delay time, XCLKOUT high to address valid | | 2 | ns |
| $t_{d(XCOHL-XRDL)}$ | Delay time, XCLKOUT high/low to $\overline{XR\overline{D}}$ active-low | | 1 | ns |
| $t_{d(XCOHL-XRDH)}$ | Delay time, XCLKOUT high/low to $\overline{XR\overline{D}}$ inactive-high | -2 | 1 | ns |
| $t_{h(XA)XZCSH}$ | Hold time, address valid after zone chip-select inactive-high | (1) | | ns |
| $t_{h(XA)XR\overline{D}}$ | Hold time, address valid after $\overline{XR\overline{D}}$ inactive-high | (1) | | ns |

(1) During inactive cycles, the XINTF address bus will always hold the last address put out on the bus. This includes alignment cycles.

Table 6-33. External Memory Interface Read Timing Requirements

| | | MIN | MAX | UNIT |
|----------------------------|---|-----|------------------------|------|
| $t_{a(A)}$ | Access time, read data from address valid | | $(LR + AR) - 14^{(1)}$ | ns |
| $t_{a(XR\overline{D})}$ | Access time, read data valid from $\overline{XR\overline{D}}$ active-low | | $AR - 12^{(1)}$ | ns |
| $t_{su(XD)XR\overline{D}}$ | Setup time, read data valid before $\overline{XR\overline{D}}$ strobe inactive-high | 12 | | ns |
| $t_{h(XD)XR\overline{D}}$ | Hold time, read data valid after $\overline{XR\overline{D}}$ inactive-high | 0 | | ns |

(1) LR = Lead period, read access. AR = Active period, read access. See [Table 6-30](#).

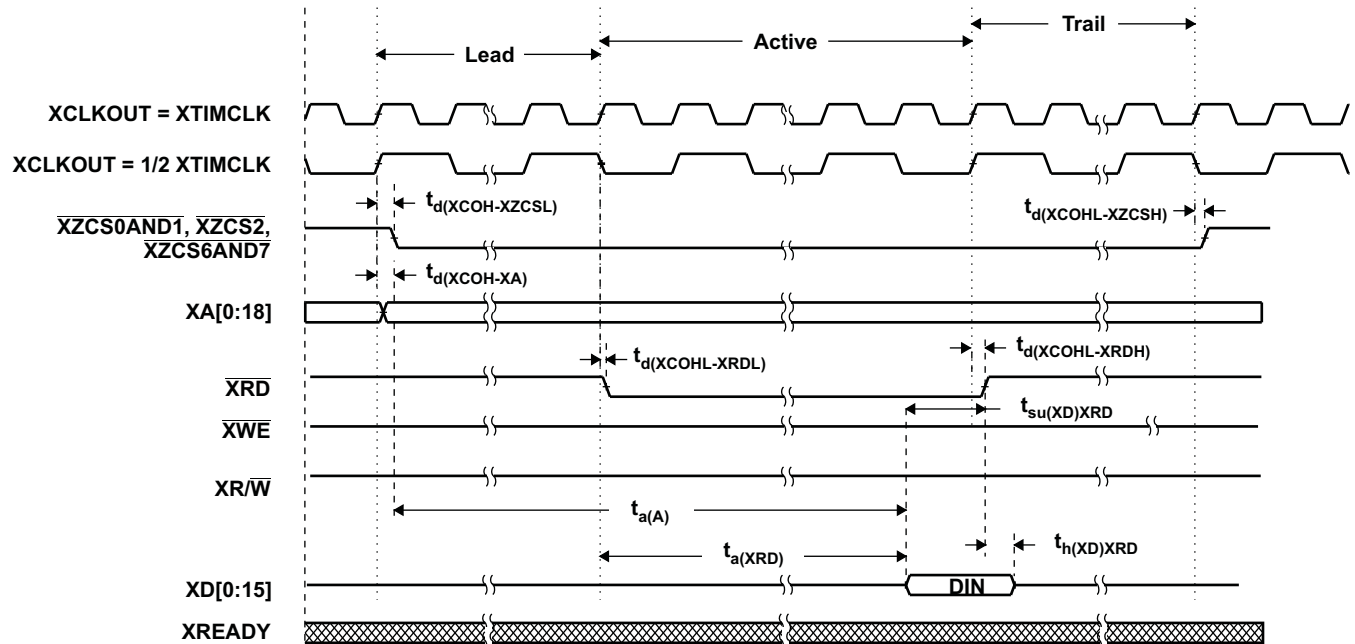

- A. All XINTF accesses (lead period) begin on the rising edge of XCLKOUT. When necessary, the device will insert an alignment cycle before an access to meet this requirement.
- B. During alignment cycles, all signals will transition to their inactive state.
- C. For USEREADY = 0, the external XREADY input signal is ignored.
- D. XA[0:18] will hold the last address put on the bus during inactive cycles, including alignment cycles.

Figure 6-31. Example Read Access

XTIMING register parameters used for this example:

| XRLEAD | XRDACTIVE | XRDTRAIL | USEREADY | X2TIMING | XWRLEAD | XWRACTIVE | XWRTRAIL | READYMODE |
|--------|-----------|----------|----------|----------|--------------------|--------------------|--------------------|--------------------|
| ≥ 1 | ≥ 0 | ≥ 0 | 0 | 0 | N/A ⁽¹⁾ | N/A ⁽¹⁾ | N/A ⁽¹⁾ | N/A ⁽¹⁾ |

(1) N/A = "Don't care" for this example

6.25 External Interface Write Timing

Table 6-34. External Memory Interface Write Switching Characteristics

| PARAMETER | | MIN | MAX | UNIT |
|----------------------|--|--------------|-----|------|
| $t_{d(XCOH-XZCSL)}$ | Delay time, XCLKOUT high to zone chip-select active-low | | 1 | ns |
| $t_{d(XCOHL-XZCSH)}$ | Delay time, XCLKOUT high or low to zone chip-select inactive-high | -2 | 3 | ns |
| $t_{d(XCOH-XA)}$ | Delay time, XCLKOUT high to address valid | | 2 | ns |
| $t_{d(XCOHL-XWEL)}$ | Delay time, XCLKOUT high/low to \overline{XWE} low | | 2 | ns |
| $t_{d(XCOHL-XWEH)}$ | Delay time, XCLKOUT high/low to \overline{XWE} high | | 2 | ns |
| $t_{d(XCOH-XRNWL)}$ | Delay time, XCLKOUT high to $\overline{XR/W}$ low | | 1 | ns |
| $t_{d(XCOHL-XRNWH)}$ | Delay time, XCLKOUT high/low to $\overline{XR/W}$ high | -2 | 1 | ns |
| $t_{en(XD)XWEL}$ | Enable time, data bus driven from \overline{XWE} low | 0 | | ns |
| $t_{d(XWEL-XD)}$ | Delay time, data valid after \overline{XWE} active-low | | 4 | ns |
| $t_{h(XA)XZCSH}$ | Hold time, address valid after zone chip-select inactive-high | | (1) | ns |
| $t_{h(XD)XWE}$ | Hold time, write data valid after \overline{XWE} inactive-high | $TW - 2$ (2) | | ns |
| $t_{dis(XD)XRNW}$ | Maximum time for DSP to release the data bus after $\overline{XR/W}$ inactive-high | | 4 | ns |

- (1) During inactive cycles, the XINTF address bus will always hold the last address put out on the bus. This includes alignment cycles.
 (2) TW = Trail period, write access. See Table 6-30.

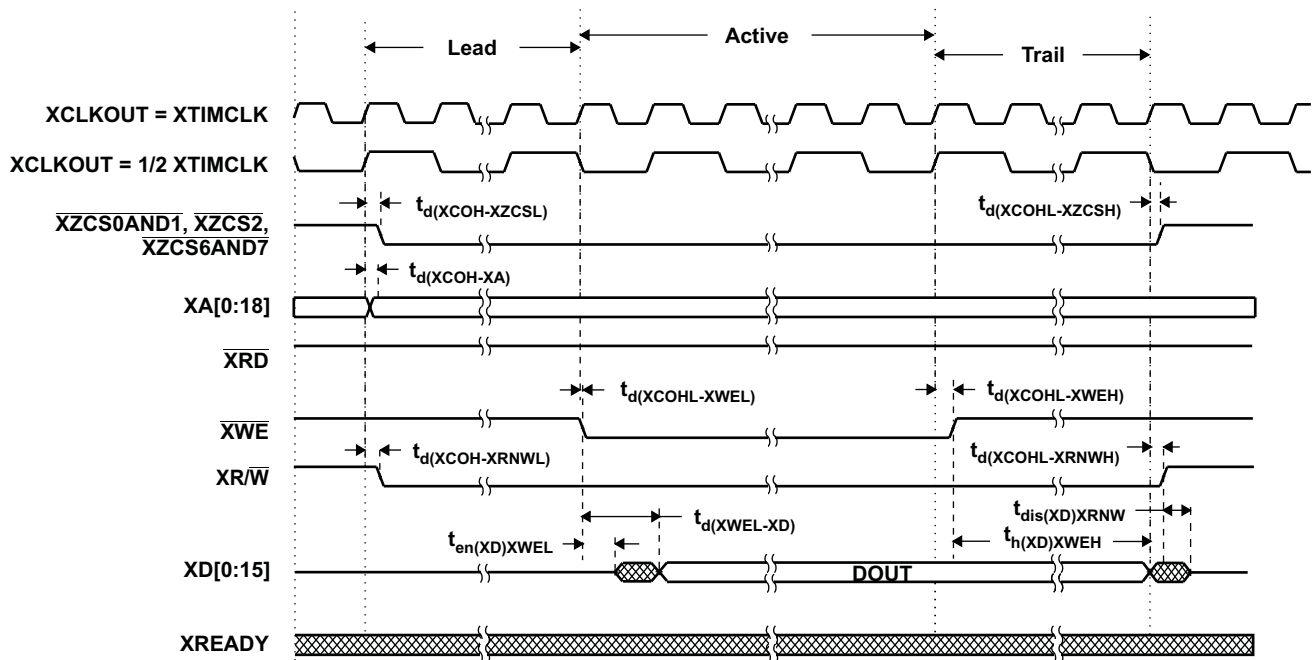

- All XINTF accesses (lead period) begin on the rising edge of XCLKOUT. When necessary, the device will insert an alignment cycle before an access to meet this requirement.
- During alignment cycles, all signals will transition to their inactive state.
- For $USEREADY = 0$, the external XREADY input signal is ignored.
- $XA[0:18]$ will hold the last address put on the bus during inactive cycles, including alignment cycles.

Figure 6-32. Example Write Access

XTIMING register parameters used for this example:

| XRDLEAD | XRDACTIVE | XRDTRAIL | USEREADY | X2TIMING | XWRLEAD | XWRACTIVE | XWRTRAIL | READYMODE |
|--------------------|--------------------|--------------------|----------|----------|----------|-----------|----------|--------------------|
| N/A ⁽¹⁾ | N/A ⁽¹⁾ | N/A ⁽¹⁾ | 0 | 0 | ≥ 1 | ≥ 0 | ≥ 0 | N/A ⁽¹⁾ |

- (1) N/A = "Don't care" for this example

6.26 External Interface Ready-on-Read Timing With One External Wait State

Table 6-35. External Memory Interface Read Switching Characteristics (Ready-on-Read, 1 Wait State)

| PARAMETER | | MIN | MAX | UNIT |
|---------------------------|---|-----|-----|------|
| $t_{d(XCOH-XZCSL)}$ | Delay time, XCLKOUT high to zone chip-select active-low | | 1 | ns |
| $t_{d(XCOHL-XZCSH)}$ | Delay time, XCLKOUT high/low to zone chip-select inactive-high | -2 | 3 | ns |
| $t_{d(XCOH-XA)}$ | Delay time, XCLKOUT high to address valid | | 2 | ns |
| $t_{d(XCOHL-XRDL)}$ | Delay time, XCLKOUT high/low to $\overline{XR\overline{D}}$ active-low | | 1 | ns |
| $t_{d(XCOHL-XRDH)}$ | Delay time, XCLKOUT high/low to $\overline{XR\overline{D}}$ inactive-high | -2 | 1 | ns |
| $t_{h(XA)XZCSH}$ | Hold time, address valid after zone chip-select inactive-high | (1) | | ns |
| $t_{h(XA)XR\overline{D}}$ | Hold time, address valid after $\overline{XR\overline{D}}$ inactive-high | (1) | | ns |

(1) During inactive cycles, the XINTF address bus will always hold the last address put out on the bus. This includes alignment cycles.

Table 6-36. External Memory Interface Read Timing Requirements (Ready-on-Read, 1 Wait State)

| | | MIN | MAX | UNIT |
|----------------------------|---|-----|-------------------------------|------|
| $t_{a(A)}$ | Access time, read data from address valid | | (LR + AR) - 14 ⁽¹⁾ | ns |
| $t_{a(XRD)}$ | Access time, read data valid from $\overline{XR\overline{D}}$ active-low | | AR - 12 ⁽¹⁾ | ns |
| $t_{su(XD)XR\overline{D}}$ | Setup time, read data valid before $\overline{XR\overline{D}}$ strobe inactive-high | 12 | | ns |
| $t_{h(XD)XR\overline{D}}$ | Hold time, read data valid after $\overline{XR\overline{D}}$ inactive-high | 0 | | ns |

(1) LR = Lead period, read access. AR = Active period, read access. See Table 6-30.

Table 6-37. Synchronous XREADY Timing Requirements (Ready-on-Read, 1 Wait State)⁽¹⁾

| | | MIN | MAX | UNIT |
|---------------------------|---|-----|-----|------|
| $t_{su(XRDYsynchL)XCOHL}$ | Setup time, XREADY (synchronous) low before XCLKOUT high/low | 15 | | ns |
| $t_{h(XRDYsynchL)}$ | Hold time, XREADY (synchronous) low | 12 | | ns |
| $t_{e(XRDYsynchH)}$ | Earliest time XREADY (synchronous) can go high before the sampling XCLKOUT edge | | 3 | ns |
| $t_{su(XRDYsynchH)XCOHL}$ | Setup time, XREADY (synchronous) high before XCLKOUT high/low | 15 | | ns |
| $t_{h(XRDYsynchH)XZCSH}$ | Hold time, XREADY (synchronous) held high after zone chip-select high | 0 | | ns |

(1) The first XREADY (synchronous) sample occurs with respect to E in Figure 6-33:

$$E = (XRDLEAD + XRDACTIVE) t_{c(XTIM)}$$

When first sampled, if XREADY (synchronous) is found to be high, then the access will complete. If XREADY (synchronous) is found to be low, it will be sampled again each $t_{c(XTIM)}$ until it is found to be high.

For each sample (n), the setup time (D) with respect to the beginning of the access can be calculated as:

$$D = (XRDLEAD + XRDACTIVE + n - 1) t_{c(XTIM)} - t_{su(XRDYsynchL)XCOHL}$$

where n is the sample number (n = 1, 2, 3, and so forth).

Table 6-38. Asynchronous XREADY Timing Requirements (Ready-on-Read, 1 Wait State)⁽¹⁾

| | | MIN | MAX | UNIT |
|----------------------------|--|-----|-----|------|
| $t_{su(XRDYAsynchL)XCOHL}$ | Setup time, XREADY (asynchronous) low before XCLKOUT high/low | 11 | | ns |
| $t_{h(XRDYAsynchL)}$ | Hold time, XREADY (asynchronous) low | 8 | | ns |
| $t_{e(XRDYAsynchH)}$ | Earliest time XREADY (asynchronous) can go high before the sampling XCLKOUT edge | | 3 | ns |
| $t_{su(XRDYAsynchH)XCOHL}$ | Setup time, XREADY (asynchronous) high before XCLKOUT high/low | 11 | | ns |
| $t_{h(XRDYAsynchH)XZCSH}$ | Hold time, XREADY (asynchronous) held high after zone chip-select high | 0 | | ns |

(1) The first XREADY (asynchronous) sample occurs with respect to E in Figure 6-34:

$$E = (XRDLEAD + XRDACTIVE - 2) t_{c(XTIM)}$$

When first sampled, if XREADY (asynchronous) is found to be high, then the access will complete. If XREADY (asynchronous) is found to be low, it will be sampled again each $t_{c(XTIM)}$ until it is found to be high.

For each sample, setup time from the beginning of the access can be calculated as:

$$D = (XRDLEAD + XRDACTIVE - 3 + n) t_{c(XTIM)} - t_{su(XRDYAsynchL)XCOHL}$$

where n is the sample number (n = 1, 2, 3, and so forth).

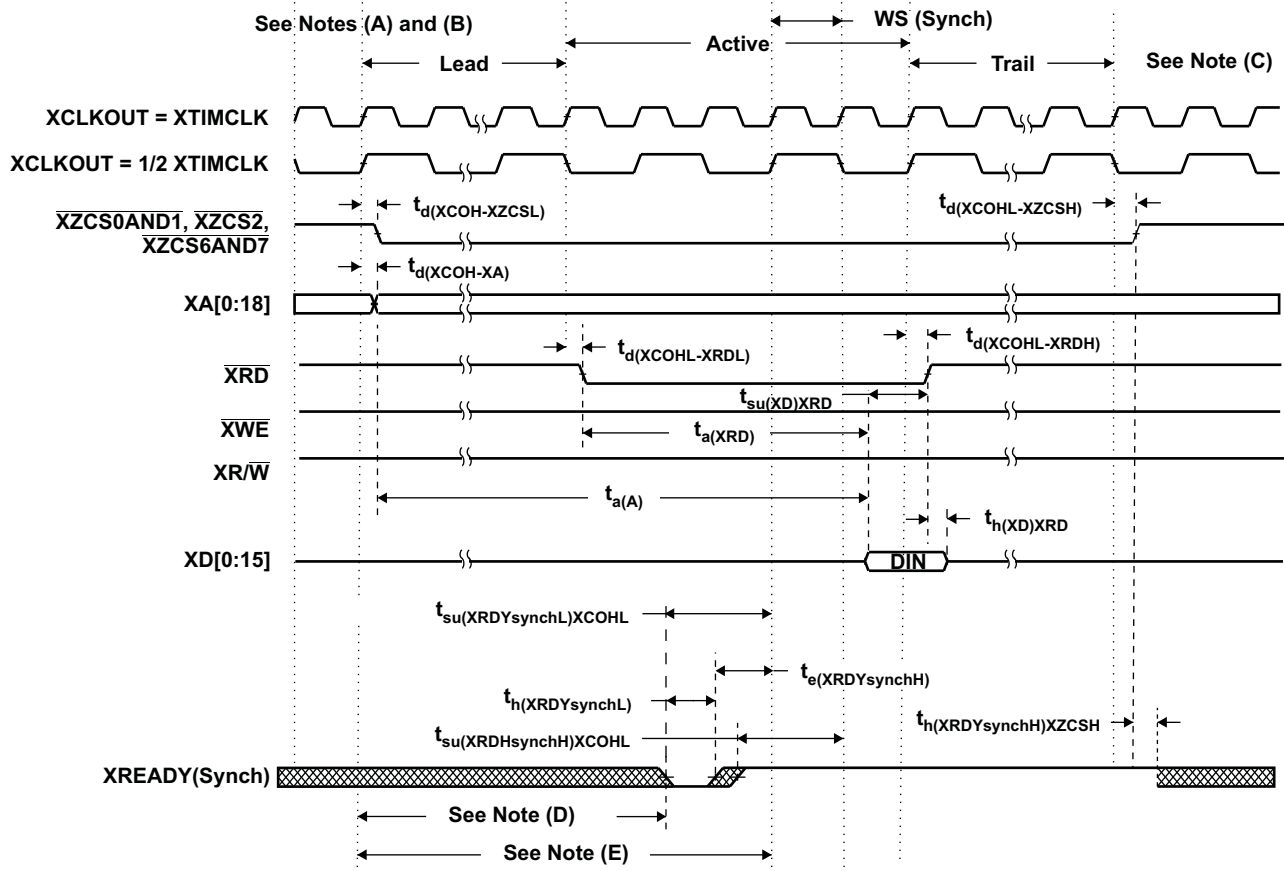

Legend:

= Don't care. Signal can be high or low during this time.

- A. All XINTF accesses (lead period) begin on the rising edge of XCLKOUT. When necessary, the device will insert an alignment cycle before an access to meet this requirement.
- B. During alignment cycles, all signals will transition to their inactive state.
- C. During inactive cycles, the XINTF address bus will always hold the last address put out on the bus. This includes alignment cycles.
- D. For each sample, setup time from the beginning of the access (D) can be calculated as:

$$D = (XRDLEAD + XRDACTIVE + n - 1) t_{c(XTIM)} - t_{su(XRDYsynchL)XCOHL}$$
- E. Reference for the first sample is with respect to this point

$$E = (XRDLEAD + XRDACTIVE) t_{c(XTIM)}$$
 where n is the sample number (n = 1, 2, 3, and so forth).

Figure 6-33. Example Read With Synchronous XREADY Access

XTIMING register parameters used for this example:

| XRDLEAD | XRDACTIVE | XRDTRAIL | USEREADY | X2TIMING | XWRLEAD | XWRACTIVE | XWRTRAIL | READYMODE |
|---------|-----------|----------|----------|----------|--------------------|--------------------|--------------------|--------------------|
| ≥ 1 | 3 | ≥ 1 | 1 | 0 | N/A ⁽¹⁾ | N/A ⁽¹⁾ | N/A ⁽¹⁾ | 0 = XREADY (Synch) |

(1) N/A = "Don't care" for this example

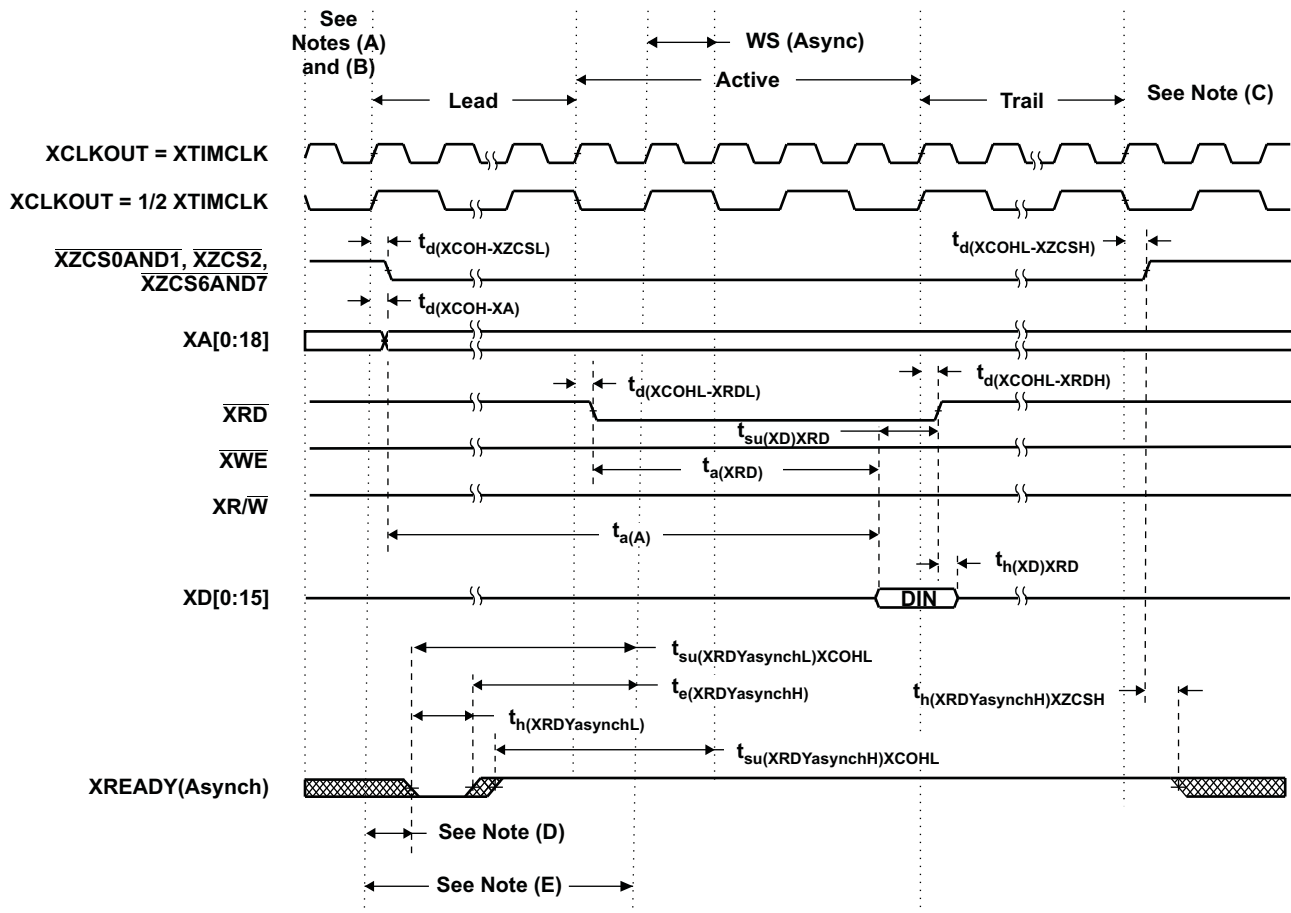

Legend:

= Don't care. Signal can be high or low during this time.

- A. All XINTF accesses (lead period) begin on the rising edge of XCLKOUT. When necessary, the device will insert an alignment cycle before an access to meet this requirement.
- B. During alignment cycles, all signals will transition to their inactive state.
- C. During inactive cycles, the XINTF address bus will always hold the last address put out on the bus. This includes alignment cycles.
- D. For each sample, setup time from the beginning of the access can be calculated as:
 $D = (XRDLEAD + XRDACTIVE - 3 + n) t_{c(XTIM)} - t_{su(XRDYasynchL)XCOHL}$
 where n is the sample number (n = 1, 2, 3, and so forth).
- E. Reference for the first sample is with respect to this point:
 $E = (XRDLEAD + XRDACTIVE - 2) t_{c(XTIM)}$

Figure 6-34. Example Read With Asynchronous XREADY Access

XTIMING register parameters used for this example:

| XRDLEAD | XRDACTIVE | XRDTRAIL | USEREADY | X2TIMING | XWRLEAD | XWRACTIVE | XWRTRAIL | READYMODE |
|---------|-----------|----------|----------|----------|--------------------|--------------------|--------------------|--------------------|
| ≥ 1 | 3 | ≥ 1 | 1 | 0 | N/A ⁽¹⁾ | N/A ⁽¹⁾ | N/A ⁽¹⁾ | 1 = XREADY (Async) |

(1) N/A = "Don't care" for this example

6.27 External Interface Ready-on-Write Timing With One External Wait State

Table 6-39. External Memory Interface Write Switching Characteristics (Ready-on-Write, 1 Wait State)

| PARAMETER | | MIN | MAX | UNIT |
|----------------------|--|----------------|-----|------|
| $t_{d(XCOH-XZCSL)}$ | Delay time, XCLKOUT high to zone chip-select active-low | | 1 | ns |
| $t_{d(XCOHL-XZCSH)}$ | Delay time, XCLKOUT high or low to zone chip-select inactive-high | -2 | 3 | ns |
| $t_{d(XCOH-XA)}$ | Delay time, XCLKOUT high to address valid | | 2 | ns |
| $t_{d(XCOHL-XWEL)}$ | Delay time, XCLKOUT high/low to \overline{XWE} low | | 2 | ns |
| $t_{d(XCOHL-XWEH)}$ | Delay time, XCLKOUT high/low to \overline{XWE} high | | 2 | ns |
| $t_{d(XCOH-XRNWL)}$ | Delay time, XCLKOUT high to $\overline{XR\overline{W}}$ low | | 1 | ns |
| $t_{d(XCOHL-XRNWH)}$ | Delay time, XCLKOUT high/low to $\overline{XR\overline{W}}$ high | -2 | 1 | ns |
| $t_{en(XD)XWEL}$ | Enable time, data bus driven from \overline{XWE} low | 0 | | ns |
| $t_{d(XWEL-XD)}$ | Delay time, data valid after \overline{XWE} active-low | | 4 | ns |
| $t_{h(XA)XZCSH}$ | Hold time, address valid after zone chip-select inactive-high | (1) | | ns |
| $t_{h(XD)XWE}$ | Hold time, write data valid after \overline{XWE} inactive-high | $TW - 2^{(2)}$ | | ns |
| $t_{dis(XD)XRNW}$ | Maximum time for DSP to release the data bus after $\overline{XR\overline{W}}$ inactive-high | | 4 | ns |

(1) During inactive cycles, the XINTF address bus will always hold the last address put out on the bus. This includes alignment cycles.

(2) TW = trail period, write access. See Table 6-30.

Table 6-40. Synchronous XREADY Timing Requirements (Ready-on-Write, 1 Wait State)⁽¹⁾

| | | MIN | MAX | UNIT |
|---------------------------|---|-----|-----|------|
| $t_{su(XRDYsynchL)XCOHL}$ | Setup time, XREADY (synchronous) low before XCLKOUT high/low | 15 | | ns |
| $t_{h(XRDYsynchL)}$ | Hold time, XREADY (synchronous) low | 12 | | ns |
| $t_{e(XRDYsynchH)}$ | Earliest time XREADY (synchronous) can go high before the sampling XCLKOUT edge | | 3 | ns |
| $t_{su(XRDYsynchH)XCOHL}$ | Setup time, XREADY (synchronous) high before XCLKOUT high/low | 15 | | ns |
| $t_{h(XRDYsynchH)XZCSH}$ | Hold time, XREADY (synchronous) held high after zone chip-select high | 0 | | ns |

(1) The first XREADY (synchronous) sample occurs with respect to E in Figure 6-35:

$$E = (XWRLEAD + XWRACTIVE) t_{c(XTIM)}$$

When first sampled, if XREADY (synchronous) is found to be high, then the access will complete. If XREADY (synchronous) is found to be low, it will be sampled again each $t_{c(XTIM)}$ until it is found to be high.

For each sample, setup time from the beginning of the access can be calculated as:

$$D = (XWRLEAD + XWRACTIVE + n - 1) t_{c(XTIM)} - t_{su(XRDYsynchL)XCOHL}$$

where n is the sample number (n = 1, 2, 3, and so forth).

Table 6-41. Asynchronous XREADY Timing Requirements (Ready-on-Write, 1 Wait State)⁽¹⁾

| | | MIN | MAX | UNIT |
|----------------------------|--|-----|-----|------|
| $t_{su(XRDYasynchL)XCOHL}$ | Setup time, XREADY (asynchronous) low before XCLKOUT high/low | 11 | | ns |
| $t_{h(XRDYasynchL)}$ | Hold time, XREADY (asynchronous) low | 8 | | ns |
| $t_{e(XRDYasynchH)}$ | Earliest time XREADY (asynchronous) can go high before the sampling XCLKOUT edge | | 3 | ns |
| $t_{su(XRDYasynchH)XCOHL}$ | Setup time, XREADY (asynchronous) high before XCLKOUT high/low | 11 | | ns |
| $t_{h(XRDYasynchH)XZCSH}$ | Hold time, XREADY (asynchronous) held high after zone chip-select high | 0 | | ns |

(1) The first XREADY (synchronous) sample occurs with respect to E in Figure 6-36:

$$E = (XWRLEAD + XWRACTIVE - 2) t_{c(XTIM)}$$

When first sampled, if XREADY (asynchronous) is found to be high, then the access will complete. If XREADY (asynchronous) is found to be low, it will be sampled again each $t_{c(XTIM)}$ until it is found to be high.

For each sample, setup time from the beginning of the access can be calculated as:

$$D = (XWRLEAD + XWRACTIVE - 3 + n) t_{c(XTIM)} - t_{su(XRDYasynchL)XCOHL}$$

where n is the sample number (n = 1, 2, 3, and so forth).

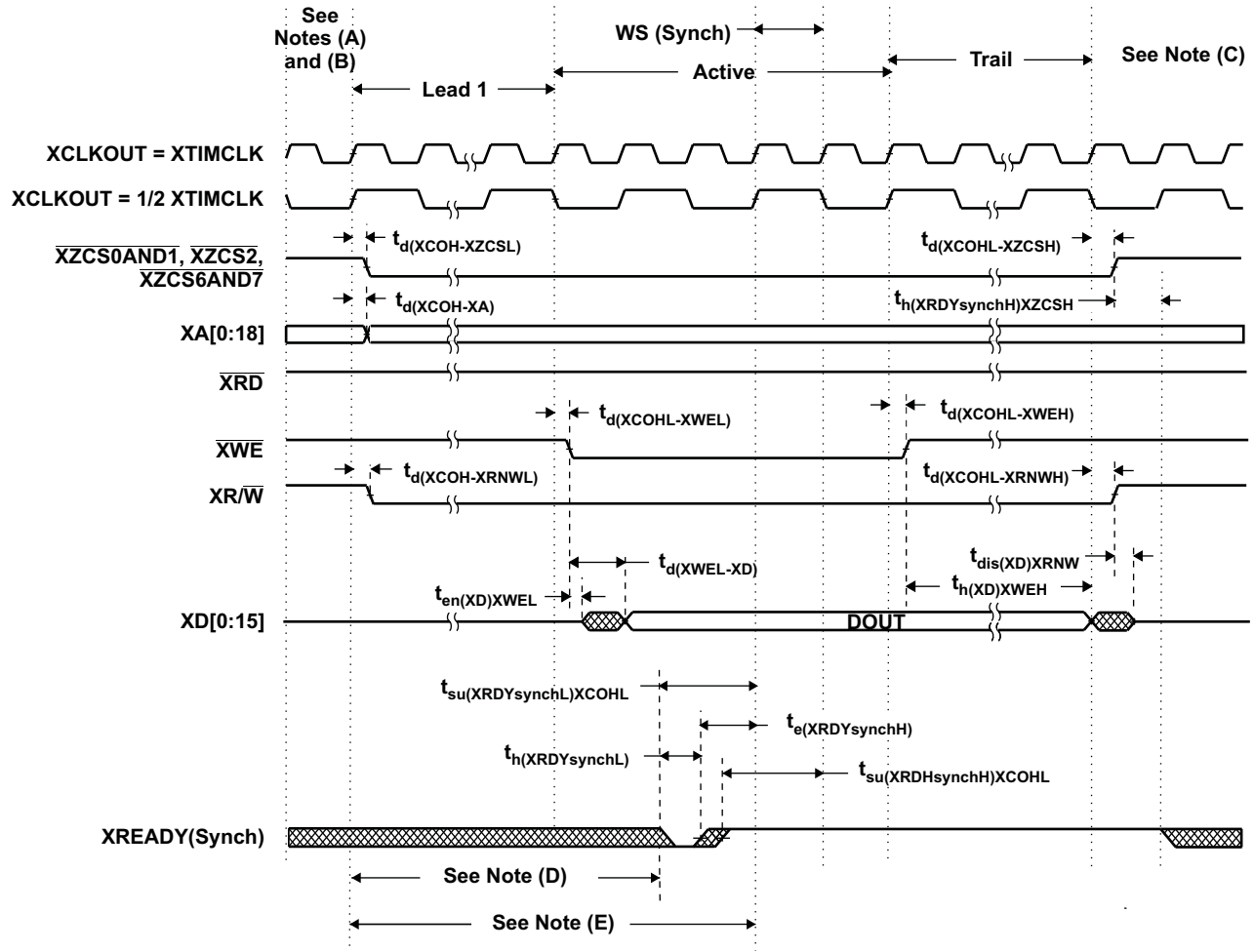

Legend:

 = Don't care. Signal can be high or low during this time.

- A. All XINTF accesses (lead period) begin on the rising edge of XCLKOUT. When necessary, the device will insert an alignment cycle before an access to meet this requirement.
- B. During alignment cycles, all signals will transition to their inactive state.
- C. During inactive cycles, the XINTF address bus will always hold the last address put out on the bus. This includes alignment cycles.
- D. For each sample, setup time from the beginning of the access can be calculated as:
 $D = (XWRLEAD + XWRACTIVE + n - 1) t_{c(XTIM)} - t_{su(XRDYsynchL)XCOHL}$
where n is the sample number (n = 1, 2, 3 and so forth).
- E. Reference for the first sample is with respect to this point
 $E = (XWRLEAD + XWRACTIVE) t_{c(XTIM)}$

Figure 6-35. Write With Synchronous XREADY Access

XTIMING register parameters used for this example:

| XRDLEAD | XRDACTIVE | XRDTRAIL | USEREADY | X2TIMING | XWRLEAD | XWRACTIVE | XWRTRAIL | READYMODE |
|--------------------|--------------------|--------------------|----------|----------|---------|-----------|----------|--------------------|
| N/A ⁽¹⁾ | N/A ⁽¹⁾ | N/A ⁽¹⁾ | 1 | 0 | ≥ 1 | 3 | ≥ 1 | 0 = XREADY (Synch) |

(1) N/A = "Don't care" for this example

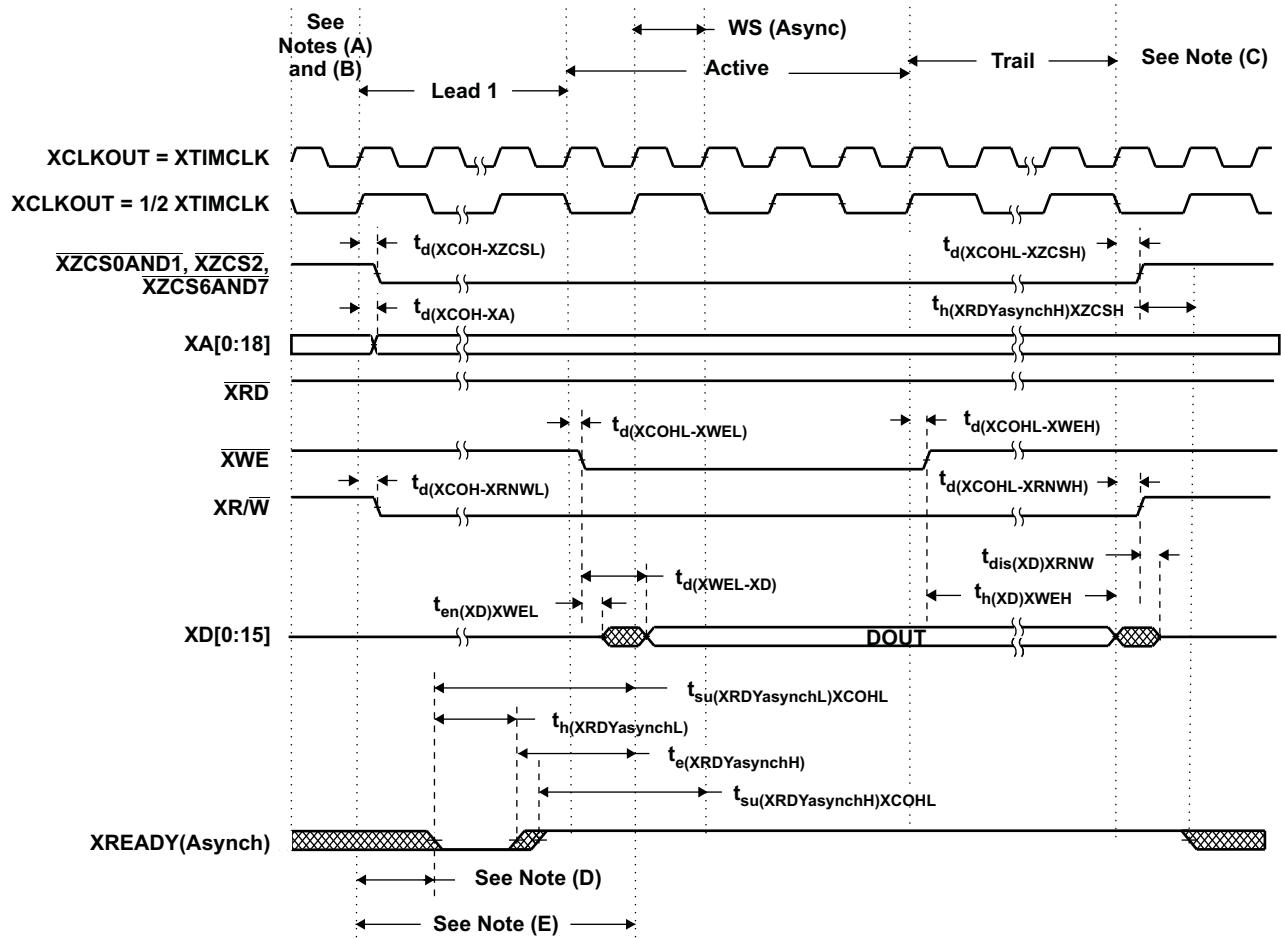

Legend:

= Don't care. Signal can be high or low during this time.

- A. All XINTF accesses (lead period) begin on the rising edge of XCLKOUT. When necessary, the device will insert an alignment cycle before an access to meet this requirement.
- B. During alignment cycles, all signals will transition to their inactive state.
- C. During inactive cycles, the XINTF address bus will always hold the last address put out on the bus. This includes alignment cycles.
- D. For each sample, setup time from the beginning of the access can be calculated as:

$$D = (XWRLEAD + XWRACTIVE - 3 + n) t_{c(XTIM)} - t_{su(XRDYasynchL)XCOHL}$$
 where n is the sample number (n = 1, 2, 3 and so forth).
- E. Reference for the first sample is with respect to this point

$$E = (XWRLEAD + XWRACTIVE - 2) t_{c(XTIM)}$$

Figure 6-36. Write With Asynchronous XREADY Access

XTIMING register parameters used for this example:

| XRDLEAD | XRDACTIVE | XRDTRAIL | USEREADY | X2TIMING | XWRLEAD | XWRACTIVE | XWRTRAIL | READYMODE |
|--------------------|--------------------|--------------------|----------|----------|---------|-----------|----------|--------------------|
| N/A ⁽¹⁾ | N/A ⁽¹⁾ | N/A ⁽¹⁾ | 1 | 0 | ≥ 1 | 3 | ≥ 1 | 1 = XREADY (Async) |

(1) N/A = "Don't care" for this example

6.28 $\overline{\text{XHOLD}}$ and $\overline{\text{XHOLDA}}$

If the HOLD mode bit is set while $\overline{\text{XHOLD}}$ and $\overline{\text{XHOLDA}}$ are both low (external bus accesses granted), the $\overline{\text{XHOLDA}}$ signal is forced high (at the end of the current cycle) and the external interface is taken out of high-impedance mode.

On a reset ($\overline{\text{XRS}}$), the HOLD mode bit is set to 0. If the $\overline{\text{XHOLD}}$ signal is active low on a system reset, the bus and all signal strobes must be in high-impedance mode, and the $\overline{\text{XHOLDA}}$ signal is also driven active low.

When HOLD mode is enabled and $\overline{\text{XHOLDA}}$ is active-low (external bus grant active), the CPU can still execute code from internal memory. If an access is made to the external interface, the CPU is stalled until the $\overline{\text{XHOLD}}$ signal is removed.

An external DMA request, when granted, places the following signals in a high-impedance mode:

| | |
|--|-------------------------------|
| $\text{XA}[18:0]$ | $\overline{\text{XZCS0AND1}}$ |
| $\text{XD}[15:0]$ | $\overline{\text{XZCS2}}$ |
| $\overline{\text{XWE}}, \overline{\text{XRD}}$ | $\overline{\text{XZCS6AND7}}$ |
| $\text{XR}/\overline{\text{W}}$ | |

All other signals not listed in this group remain in their default or functional operational modes during these signal events.

6.29 XHOLD/XHOLDA Timing

Table 6-42. XHOLD/XHOLDA Timing Requirements (XCLKOUT = XTIMCLK)⁽¹⁾⁽²⁾

| | | MIN | MAX | UNIT |
|-----------------|---|-----|----------------|------|
| $t_{d(HL-HiZ)}$ | Delay time, XHOLD low to Hi-Z on all Address, Data, and Control | | $4t_{c(XTIM)}$ | ns |
| $t_{d(HL-HAL)}$ | Delay time, XHOLD low to XHOLDA low | | $5t_{c(XTIM)}$ | ns |
| $t_{d(HH-HAH)}$ | Delay time, XHOLD high to XHOLDA high | | $3t_{c(XTIM)}$ | ns |
| $t_{d(HH-BV)}$ | Delay time, XHOLD high to Bus valid | | $4t_{c(XTIM)}$ | ns |

- (1) When a low signal is detected on XHOLD, all pending XINTF accesses will be completed before the bus is placed in a high-impedance state.
- (2) The state of XHOLD is latched on the rising edge of XTIMCLK.

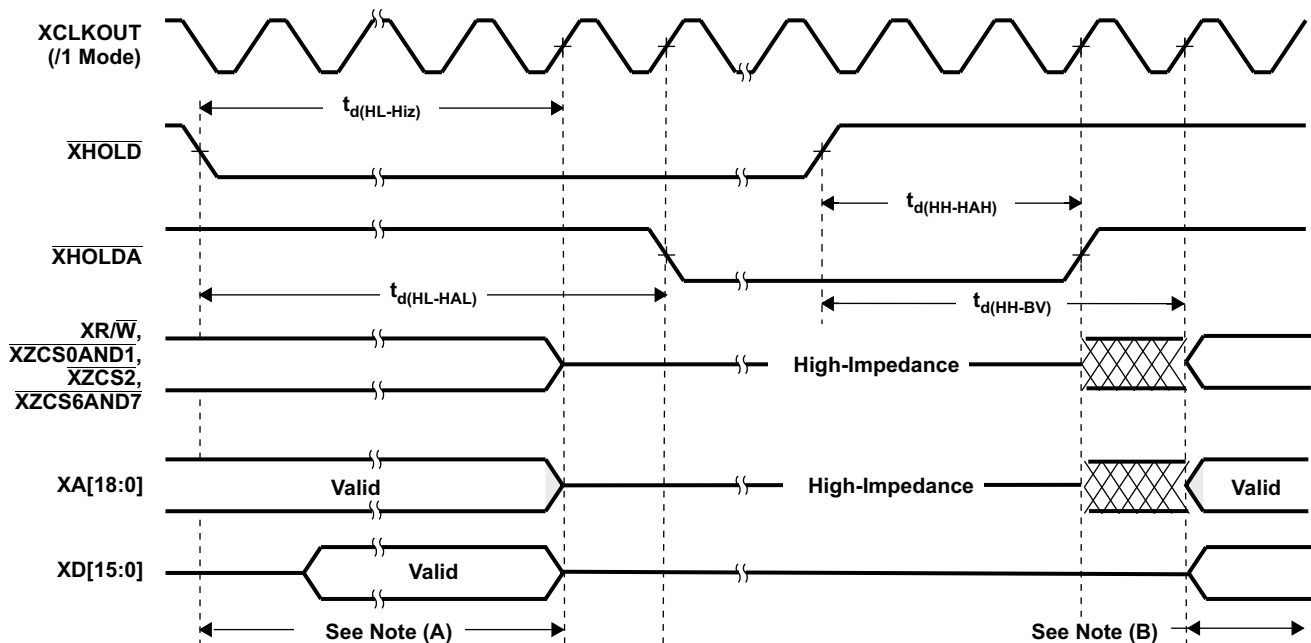

- A. All pending XINTF accesses are completed.
- B. Normal XINTF operation resumes.

Figure 6-37. External Interface Hold Waveform

Table 6-43. $\overline{\text{XHOLD}}/\overline{\text{XHOLDA}}$ Timing Requirements ($\text{XCLKOUT} = 1/2 \text{XTIMCLK}$)⁽¹⁾⁽²⁾⁽³⁾

| | | MIN | MAX | UNIT |
|------------------------|---|-----|--|------|
| $t_{d(\text{HL-HiZ})}$ | Delay time, $\overline{\text{XHOLD}}$ low to Hi-Z on all Address, Data, and Control | | $4t_{c(\text{XTIM})} + t_{c(\text{XCO})}$ | ns |
| $t_{d(\text{HL-HAL})}$ | Delay time, $\overline{\text{XHOLD}}$ low to $\overline{\text{XHOLDA}}$ low | | $4t_{c(\text{XTIM})} + 2t_{c(\text{XCO})}$ | ns |
| $t_{d(\text{HH-HAH})}$ | Delay time, $\overline{\text{XHOLD}}$ high to $\overline{\text{XHOLDA}}$ high | | $4t_{c(\text{XTIM})}$ | ns |
| $t_{d(\text{HH-BV})}$ | Delay time, $\overline{\text{XHOLD}}$ high to Bus valid | | $6t_{c(\text{XTIM})}$ | ns |

- (1) When a low signal is detected on $\overline{\text{XHOLD}}$, all pending XINTF accesses will be completed before the bus is placed in a high-impedance state.
- (2) The state of $\overline{\text{XHOLD}}$ is latched on the rising edge of XTIMCLK.
- (3) After the $\overline{\text{XHOLD}}$ is detected low or high, all bus transitions and $\overline{\text{XHOLDA}}$ transitions will occur with respect to the rising edge of XCLKOUT. Thus, for this mode where $\text{XCLKOUT} = 1/2 \text{XTIMCLK}$, the transitions can occur up to 1 XTIMCLK cycle earlier than the maximum value specified.

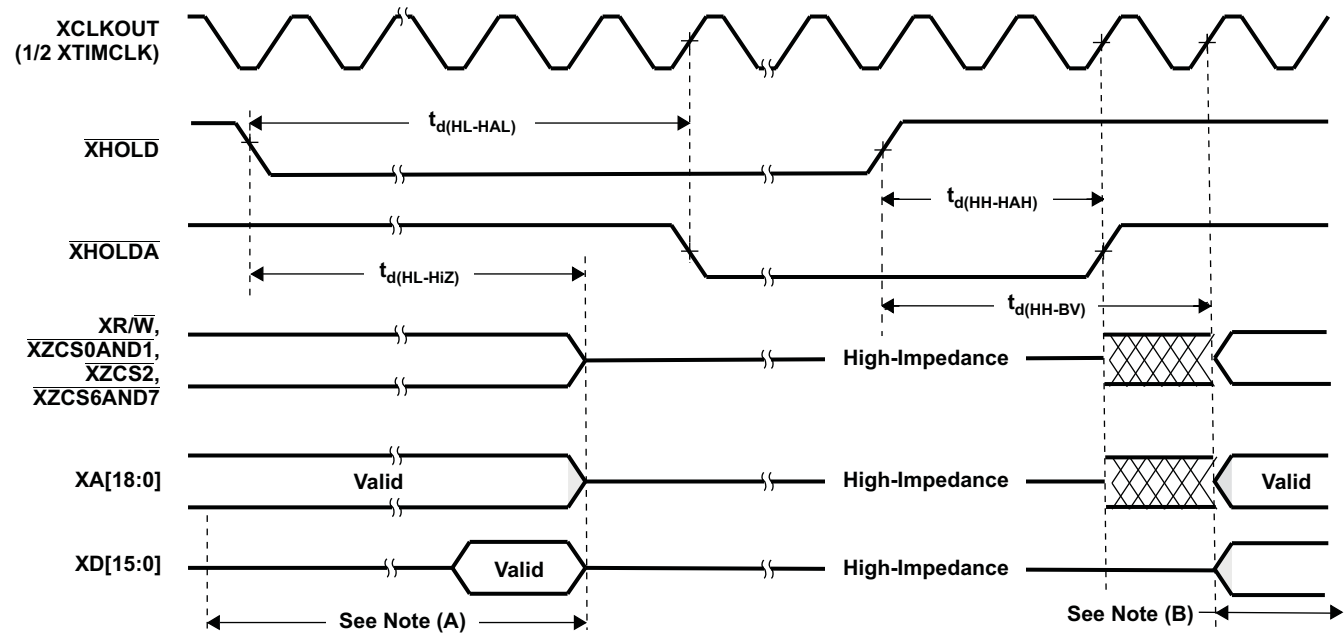

- A. All pending XINTF accesses are completed.
- B. Normal XINTF operation resumes.

Figure 6-38. $\overline{\text{XHOLD}}/\overline{\text{XHOLDA}}$ Timing Requirements ($\text{XCLKOUT} = 1/2 \text{XTIMCLK}$)

6.30 On-Chip Analog-to-Digital Converter

6.30.1 ADC Absolute Maximum Ratings

Unless otherwise noted, the list of absolute maximum ratings are specified over operating conditions. Stresses beyond those listed under Absolute Maximum Ratings may cause permanent damage to the device. These are stress ratings only. Exposure to absolute-maximum-rated conditions for extended periods may affect device reliability.

| | |
|---|----------------------------|
| Supply voltage range (V_{SSA1}/V_{SSA2} to $V_{DDA1}/V_{DDA2}/AVDDREFBG$) | –0.3 V to 4.6 V |
| Supply voltage range (V_{SS1} to V_{DD1}) | –0.3 V to 2.5 V |
| Analog Input (ADCIN) Clamp Current, total (max) | ± 20 mA ⁽¹⁾ |

- (1) The analog inputs have an internal clamping circuit that clamps the voltage to a diode drop above V_{DDA} or below V_{SS} . The continuous clamp current per pin is ± 2 mA.

6.30.2 ADC Electrical Characteristics Over Recommended Operating Conditions

Table 6-44. DC Specifications⁽¹⁾

| PARAMETER | | MIN | TYP | MAX | UNIT |
|---|-----------------------------------|------|-----|------|--------|
| Resolution | | 12 | | | Bits |
| ADC clock ⁽²⁾ | | 1 | | | kHz |
| | | | | 25 | MHz |
| ACCURACY | | | | | |
| INL (Integral nonlinearity) ⁽³⁾ | 1–18.75 MHz ADC clock | | | ±1.5 | LSB |
| DNL (Differential nonlinearity) ⁽³⁾ | 1–18.75 MHz ADC clock | | | ±1 | LSB |
| Offset error ⁽⁴⁾ | | –80 | | 80 | LSB |
| Overall gain error with internal reference ⁽⁵⁾ | F281x | –200 | | 200 | LSB |
| | C281x | –80 | | 80 | |
| Overall gain error with external reference ⁽⁶⁾ | If ADCREFP – ADCREFM = 1 V ± 0.1% | –50 | | 50 | LSB |
| Channel-to-channel offset variation | | | ±8 | | LSB |
| Channel-to-channel Gain variation | | | ±8 | | LSB |
| ANALOG INPUT | | | | | |
| Analog input voltage (ADCINx to ADCLO) ⁽⁷⁾ | | 0 | | 3 | V |
| ADCLO | | –5 | 0 | 5 | mV |
| Input capacitance | | | 10 | | pF |
| Input leakage current | | | 3 | ±5 | µA |
| INTERNAL VOLTAGE REFERENCE⁽⁵⁾ | | | | | |
| Accuracy, ADCV _{REFP} | | 1.9 | 2 | 2.1 | V |
| Accuracy, ADCV _{REFM} | | 0.95 | 1 | 1.05 | V |
| Voltage difference, ADCREFP – ADCREFM | | | 1 | | V |
| Temperature coefficient | | | 50 | | PPM/°C |
| Reference noise | | | 100 | | µV |
| EXTERNAL VOLTAGE REFERENCE⁽⁶⁾ | | | | | |
| Accuracy, ADCV _{REFP} | | 1.9 | 2 | 2.1 | V |
| Accuracy, ADCV _{REFM} | | 0.95 | 1 | 1.05 | V |
| Input voltage difference, ADCREFP – ADCREFM | | 0.99 | 1 | 1.01 | V |

- (1) Tested at 12.5-MHz ADCCLK.
- (2) If SYSCLKOUT ≤ 25 MHz, ADC clock ≤ SYSCLKOUT/2.
- (3) The INL degrades for frequencies beyond 18.75 MHz–25 MHz. Applications that require these sampling rates should use a 20K resistor as bias resistor on the ADCRESEXT pin. This improves overall linearity and typical current drawn by the ADC will be a few mA more than 24.9-kΩ bias. The ADC module in C281x devices can operate at 24.9k bias on ADCRESEXT pin for the full range 1–25 MHz.
- (4) 1 LSB has the weighted value of $3.0/4096 = 0.732$ mV.
- (5) A single internal band gap reference (±5% accuracy) sources both ADCREFP and ADCREFM signals, and hence, these voltages track together. The ADC converter uses the difference between these two as its reference. The total gain error will be the combination of the gain error shown here and the voltage reference accuracy (ADCREFP – ADCREFM). A software-based calibration procedure is recommended for better accuracy. See the *F2810, F2811, and F2812 ADC Calibration Application Report* (literature number [SPRA989](#)) and [Section 5.2](#), Documentation Support, for relevant documents.
- (6) In this mode, the accuracy of external reference is critical for overall gain. The voltage difference (ADCREFP – ADCREFM) will determine the overall accuracy.
- (7) Voltages above $V_{DDA} + 0.3$ V or below $V_{SS} - 0.3$ V applied to an analog input pin may temporarily affect the conversion of another pin. To avoid this, the analog inputs should be kept within these limits.

Table 6-45. AC Specifications

| PARAMETER | | MIN | TYP | MAX | UNIT |
|---------------|------------------------------------|-----|------|-----|------|
| SINAD | Signal-to-noise ratio + distortion | | 62 | | dB |
| SNR | Signal-to-noise ratio | | 62 | | dB |
| THD (100 kHz) | Total harmonic distortion | | -68 | | dB |
| ENOB (SNR) | Effective number of bits | | 10.1 | | Bits |
| SFDR | Spurious free dynamic range | | 69 | | dB |

6.30.3 Current Consumption for Different ADC Configurations

Table 6-46. Current Consumption for Different ADC Configurations (at 25-MHz ADCCLK)⁽¹⁾

| I _{DDA} (TYP) ⁽²⁾ | I _{DDAIO} (TYP) | I _{DD1} (TYP) | ADC OPERATING MODE/CONDITIONS |
|---------------------------------------|--------------------------|------------------------|---|
| 40 mA | 1 μA | 0.5 mA | Mode A (Operational Mode): • BG and REF enabled • PWD disabled |
| 7 mA | 0 | 5 μA | Mode B: • ADC clock enabled • BG and REF enabled • PWD enabled |
| 1 μA | 0 | 5 μA | Mode C: • ADC clock enabled • BG and REF disabled • PWD enabled |
| 1 μA | 0 | 0 | Mode D: • ADC clock disabled • BG and REF disabled • PWD enabled |

- (1) Test Conditions:
- SYSCLKOUT = 150 MHz
 - ADC module clock = 25 MHz
 - ADC performing a continuous conversion of all 16 channels in Mode A
- (2) I_{DDA} – includes current into V_{DDA1}/V_{DDA2} and AVDDREFBG

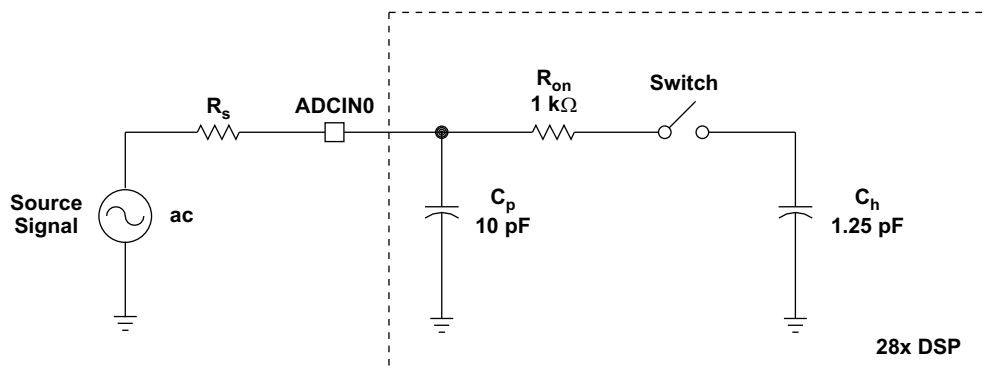

Typical Values of the Input Circuit Components:

- Switch Resistance (R_{on}): 1 kΩ
- Sampling Capacitor (C_h): 1.25 pF
- Parasitic Capacitance (C_p): 10 pF
- Source Resistance (R_s): 50 Ω

Figure 6-39. ADC Analog Input Impedance Model

6.30.4 ADC Power-Up Control Bit Timing

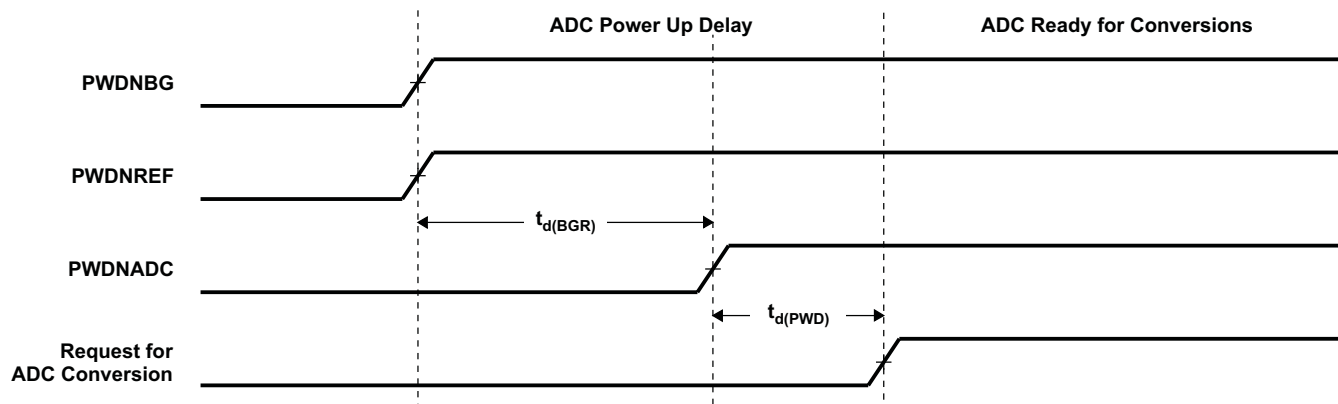

Figure 6-40. ADC Power-Up Control Bit Timing

Table 6-47. ADC Power-Up Delays⁽¹⁾

| | | MIN | TYP | MAX | UNIT |
|--------------|---|-----|-----|-----|---------|
| $t_{d(BGR)}$ | Delay time for band gap reference to be stable. Bits 7 and 6 of the ADCTRL3 register (ADCBGRFDN1/0) are to be set to 1 before the ADCPWDN bit is enabled. | 7 | 8 | 10 | ms |
| $t_{d(PWD)}$ | Delay time for power-down control to be stable. Bit 5 of the ADCTRL3 register (ADCPWDN) is to be set to 1 before any ADC conversions are initiated. | 20 | 50 | | μ s |
| | | | | 1 | ms |

(1) These delays are necessary and recommended to make the ADC analog reference circuit stable before conversions are initiated. If conversions are started without these delays, the ADC results will show a higher gain. For power down, all three bits can be cleared at the same time.

6.30.5 Detailed Description

6.30.5.1 Reference Voltage

The on-chip ADC has a built-in reference, which provides the reference voltages for the ADC. ADCVREFP is set to 2.0 V and ADCVREFM is set to 1.0 V.

6.30.5.2 Analog Inputs

The on-chip ADC consists of 16 analog inputs, which are sampled either one at a time or two channels at a time. These inputs are software-selectable.

6.30.5.3 Converter

The on-chip ADC uses a 12-bit four-stage pipeline architecture, which achieves a high sample rate with low power consumption.

6.30.5.4 Conversion Modes

The conversion can be performed in two different conversion modes:

- Sequential sampling mode (SMODE = 0)
- Simultaneous sampling mode (SMODE = 1)

6.30.6 Sequential Sampling Mode (Single-Channel) (SMODE = 0)

In sequential sampling mode, the ADC can continuously convert input signals on any of the channels (Ax to Bx). The ADC can start conversions on event triggers from the Event Managers (EVA/EVB), software trigger, or from an external ADCSOC signal. If the SMODE bit is 0, the ADC will do conversions on the selected channel on every Sample/Hold pulse. The conversion time and latency of the Result register update are explained below. The ADC interrupt flags are set a few SYSCLKOUT cycles after the Result register update. The selected channels will be sampled at every falling edge of the Sample/Hold pulse. The Sample/Hold pulse width can be programmed to be 1 ADC clock wide (minimum) or 16 ADC clocks wide (maximum).

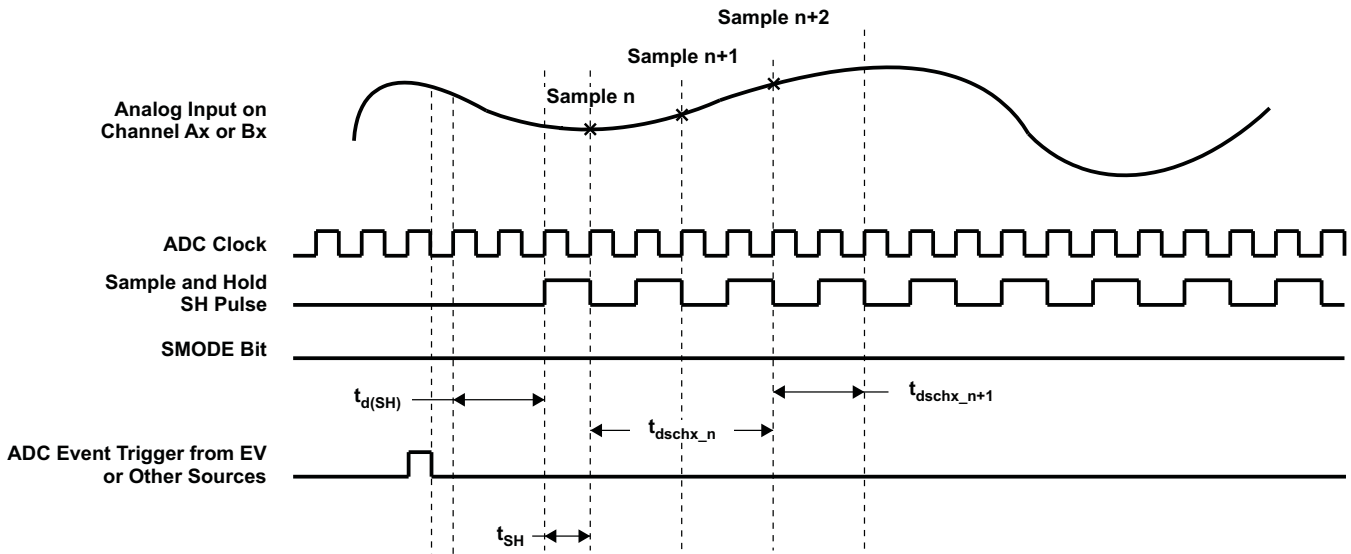

Figure 6-41. Sequential Sampling Mode (Single-Channel) Timing

Table 6-48. Sequential Sampling Mode Timing

| | | SAMPLE n | SAMPLE n + 1 | AT 25-MHz ADC CLOCK, $t_c(\text{ADCCLK}) = 40 \text{ ns}$ | REMARKS |
|----------------------------|--|---|---|---|-------------------------------------|
| $t_{d(\text{SH})}$ | Delay time from event trigger to sampling | $2.5t_c(\text{ADCCLK})$ | | | |
| t_{SH} | Sample/ Hold width/ Acquisition width | $(1 + \text{Acqps}) * t_c(\text{ADCCLK})$ | | 40 ns with Acqps = 0 | Acqps value = 0–15 ADCTRL1[8:11] |
| $t_{d(\text{schx}_n)}$ | Delay time for first result to appear in the Result register | $4t_c(\text{ADCCLK})$ | | 160 ns | |
| $t_{d(\text{schx}_{n+1})}$ | Delay time for successive results to appear in the Result register | | $(2 + \text{Acqps}) * t_c(\text{ADCCLK})$ | 80 ns | |

6.30.7 Simultaneous Sampling Mode (Dual-Channel) (SMODE = 1)

In simultaneous mode, the ADC can continuously convert input signals on any one pair of channels (A0/B0 to A7/B7). The ADC can start conversions on event triggers from the Event Managers (EVA/EVB), software trigger, or from an external ADCSOC signal. If the SMODE bit is 1, the ADC will do conversions on two selected channels on every Sample/Hold pulse. The conversion time and latency of the Result register update are explained below. The ADC interrupt flags are set a few SYSCLKOUT cycles after the Result register update. The selected channels will be sampled simultaneously at the falling edge of the Sample/Hold pulse. The Sample/Hold pulse width can be programmed to be 1 ADC clock wide (minimum) or 16 ADC clocks wide (maximum).

NOTE

In Simultaneous Mode, the ADCIN channel pair select has to be A0/B0, A1/B1, ..., A7/B7, and *not* in other combinations (such as A1/B3, and so forth).

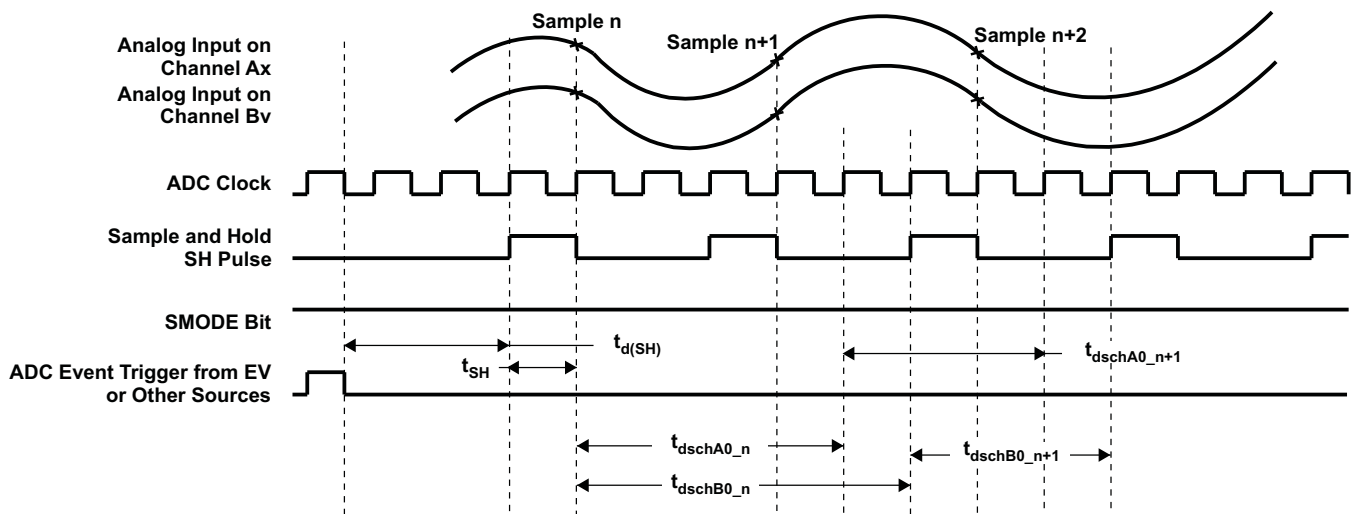

Figure 6-42. Simultaneous Sampling Mode Timing

Table 6-49. Simultaneous Sampling Mode Timing

| | | SAMPLE n | SAMPLE n + 1 | AT 25-MHz ADC CLOCK, t _c (ADCCLK) = 40 ns | REMARKS |
|----------------------------|--|---------------------------------------|---------------------------------------|--|-------------------------------------|
| t _d (SH) | Delay time from event trigger to sampling | 2.5t _c (ADCCLK) | | | |
| t _{SH} | Sample/Hold width/ Acquisition Width | (1 + Acqps) * t _c (ADCCLK) | | 40 ns with Acqps = 0 | Acqps value = 0–15 ADCTRL1[8:11] |
| t _d (schA0_n) | Delay time for first result to appear in Result register | 4t _c (ADCCLK) | | 160 ns | |
| t _d (schB0_n) | Delay time for first result to appear in Result register | 5t _c (ADCCLK) | | 200 ns | |
| t _d (schA0_n+1) | Delay time for successive results to appear in Result register | | (3 + Acqps) * t _c (ADCCLK) | 120 ns | |
| t _d (schB0_n+1) | Delay time for successive results to appear in Result register | | (3 + Acqps) * t _c (ADCCLK) | 120 ns | |

6.30.8 Definitions of Specifications and Terminology

Integral Nonlinearity

Integral nonlinearity refers to the deviation of each individual code from a line drawn from zero through full scale. The point used as zero occurs 1/2 LSB before the first code transition. The full-scale point is defined as level 1/2 LSB beyond the last code transition. The deviation is measured from the center of each particular code to the true straight line between these two points.

Differential Nonlinearity

An ideal ADC exhibits code transitions that are exactly 1 LSB apart. DNL is the deviation from this ideal value. A differential nonlinearity error of less than ± 1 LSB ensures no missing codes.

Zero Offset

The major carry transition should occur when the analog input is at zero volt. Zero error is defined as the deviation of the actual transition from that point.

Gain Error

The first code transition should occur at an analog value 1/2 LSB above negative full scale. The last transition should occur at an analog value 1 1/2 LSB below the nominal full scale. Gain error is the deviation of the actual difference between first and last code transitions and the ideal difference between first and last code transitions.

Signal-to-Noise Ratio + Distortion (SINAD)

SINAD is the ratio of the rms value of the measured input signal to the rms sum of all other spectral components below the Nyquist frequency, including harmonics but excluding dc. The value for SINAD is expressed in decibels.

Effective Number of Bits (ENOB)

For a sine wave, SINAD can be expressed in terms of the number of bits. Using the following formula,

$$N = \frac{(\text{SINAD} - 1.76)}{6.02}$$

it is possible to get a measure of performance expressed as N, the effective number of bits. Thus, effective number of bits for a device for sine wave inputs at a given input frequency can be calculated directly from its measured SINAD.

Total Harmonic Distortion (THD)

THD is the ratio of the rms sum of the first six harmonic components to the rms value of the measured input signal and is expressed as a percentage or in decibels.

Spurious Free Dynamic Range (SFDR)

SFDR is the difference in dB between the rms amplitude of the input signal and the peak spurious signal.

6.31 Multichannel Buffered Serial Port (McBSP) Timing

6.31.1 McBSP Transmit and Receive Timing

Table 6-50. McBSP Timing Requirements⁽¹⁾⁽²⁾

| NO. | | | MIN | MAX | UNIT |
|-----|--|---|------------|-------------------|------|
| | McBSP module clock (CLKG, CLKX, CLKR) range | | 1 | | kHz |
| | | | | 20 ⁽³⁾ | MHz |
| | McBSP module cycle time (CLKG, CLKX, CLKR) range | | 50 | | ns |
| | | | | 1 | ms |
| M11 | $t_{c(CKRX)}$ | Cycle time, CLKR/X | CLKR/X ext | 2P | ns |
| M12 | $t_{w(CKRX)}$ | Pulse duration, CLKR/X high or CLKR/X low | CLKR/X ext | P – 7 | ns |
| M13 | $t_{r(CKRX)}$ | Rise time, CLKR/X | CLKR/X ext | 7 | ns |
| M14 | $t_{f(CKRX)}$ | Fall time, CLKR/X | CLKR/X ext | 7 | ns |
| M15 | $t_{su(FRH-CKRL)}$ | Setup time, external FSR high before CLKR low | CLKR int | 18 | ns |
| | | | CLKR ext | 2 | |
| M16 | $t_{h(CKRL-FRH)}$ | Hold time, external FSR high after CLKR low | CLKR int | 0 | ns |
| | | | CLKR ext | 6 | |
| M17 | $t_{su(DRV-CKRL)}$ | Setup time, DR valid before CLKR low | CLKR int | 18 | ns |
| | | | CLKR ext | 2 | |
| M18 | $t_{h(CKRL-DRV)}$ | Hold time, DR valid after CLKR low | CLKR int | 0 | ns |
| | | | CLKR ext | 6 | |
| M19 | $t_{su(FXH-CKXL)}$ | Setup time, external FSX high before CLKX low | CLKX int | 18 | ns |
| | | | CLKX ext | 2 | |
| M20 | $t_{h(CKXL-FXH)}$ | Hold time, external FSX high after CLKX low | CLKX int | 0 | ns |
| | | | CLKX ext | 6 | |

- (1) Polarity bits CLKRP = CLKXP = FSRP = FSXP = 0. If the polarity of any of the signals is inverted, then the timing references of that signal are also inverted.
- (2) 2P = 1/CLKG in ns. CLKG is the output of sample rate generator mux. CLKG = CLKSRG/(1 + CLKGDV). CLKSRG can be LSPCLK, CLKX, CLKR as source. CLKSRG ≤ (SYSCLKOUT/2). McBSP performance is limited by I/O buffer switching speed.
- (3) Internal clock prescalers must be adjusted such that the McBSP clock (CLKG, CLKX, CLKR) speeds are not greater than the I/O buffer speed limit (20 MHz).

Table 6-51. McBSP Switching Characteristics⁽¹⁾⁽²⁾

| NO. | PARAMETER | | MIN | MAX | UNIT | | |
|-----|------------------------------------|---|------------|---|--------|----|--------|
| M1 | $t_c(\text{CKRX})$ | Cycle time, CLKR/X | CLKR/X int | 2P | ns | | |
| M2 | $t_w(\text{CKRXH})$ | Pulse duration, CLKR/X high | CLKR/X int | D – 5 ⁽³⁾ D + 5 ⁽³⁾ | ns | | |
| M3 | $t_w(\text{CKRXL})$ | Pulse duration, CLKR/X low | CLKR/X int | C – 5 ⁽³⁾ C + 5 ⁽³⁾ | ns | | |
| M4 | $t_d(\text{CKRH-FRV})$ | Delay time, CLKR high to internal FSR valid | CLKR int | 0 4 | ns | | |
| | | | CLKR ext | 3 27 | | | |
| M5 | $t_d(\text{CKXH-FXV})$ | Delay time, CLKX high to internal FSX valid | CLKX int | 0 4 | ns | | |
| | | | CLKX ext | 3 27 | | | |
| M6 | $t_{\text{dis}}(\text{CKXH-DXHZ})$ | Disable time, CLKX high to DX high impedance following last data bit | CLKX int | | 8 | ns | |
| | | | CLKX ext | | 14 | | |
| M7 | $t_d(\text{CKXH-DXV})$ | Delay time, CLKX high to DX valid. This applies to all bits except the first bit transmitted. | CLKX int | | 9 | ns | |
| | | | CLKX ext | | 28 | | |
| | | Delay time, CLKX high to DX valid. Only applies to first bit transmitted when in Data Delay 1 or 2 (XDATDLY = 01b or 10b) modes. | DXENA = 0 | CLKX int | | | 8 |
| | | | DXENA = 1 | CLKX int | | | P + 8 |
| | | | DXENA = 0 | CLKX ext | | | 14 |
| | | | DXENA = 1 | CLKX ext | | | P + 14 |
| M8 | $t_{\text{en}}(\text{CKXH-DX})$ | Enable time, CLKX high to DX driven. Only applies to first bit transmitted when in Data Delay 1 or 2 (XDATDLY = 01b or 10b) modes. | DXENA = 0 | CLKX int | 0 | ns | |
| | | | DXENA = 1 | CLKX int | P | | |
| | | | DXENA = 0 | CLKX ext | 6 | | |
| | | | DXENA = 1 | CLKX ext | P + 6 | | |
| M9 | $t_d(\text{FXH-DXV})$ | Delay time, FSX high to DX valid. Only applies to first bit transmitted when in Data Delay 0 (XDATDLY = 00b) mode. | DXENA = 0 | FSX int | 8 | ns | |
| | | | DXENA = 1 | FSX int | P + 8 | | |
| | | | DXENA = 0 | FSX ext | 14 | | |
| | | | DXENA = 1 | FSX ext | P + 14 | | |
| M10 | $t_{\text{en}}(\text{FXH-DX})$ | Enable time, FSX high to DX driven. Only applies to first bit transmitted when in Data Delay 0 (XDATDLY = 00b) mode. | DXENA = 0 | FSX int | 0 | ns | |
| | | | DXENA = 1 | FSX int | P | | |
| | | | DXENA = 0 | FSX ext | 6 | | |
| | | | DXENA = 1 | FSX ext | P + 6 | | |

(1) Polarity bits CLKRP = CLKXP = FSRP = FSXP = 0. If the polarity of any of the signals is inverted, then the timing references of that signal are also inverted.

(2) 2P = 1/CLKG in ns.

(3) C = CLKRX low pulse width = P
D = CLKRX high pulse width = P

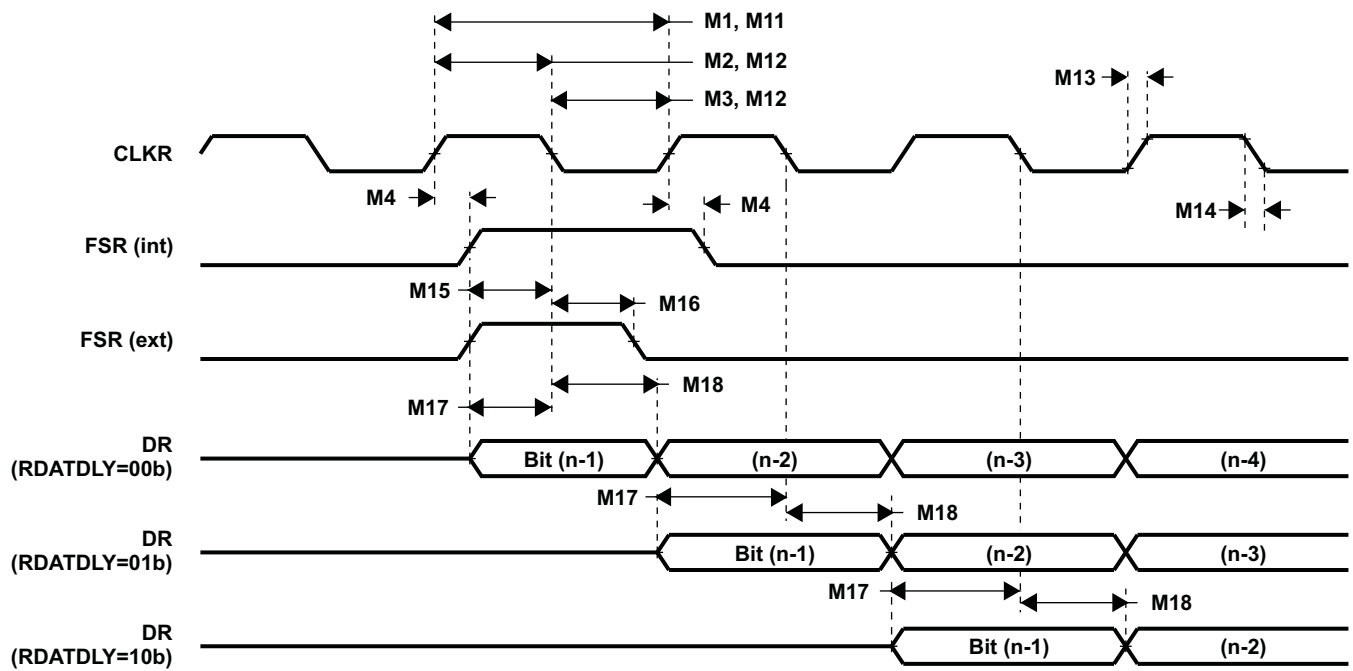

Figure 6-43. McBSP Receive Timing

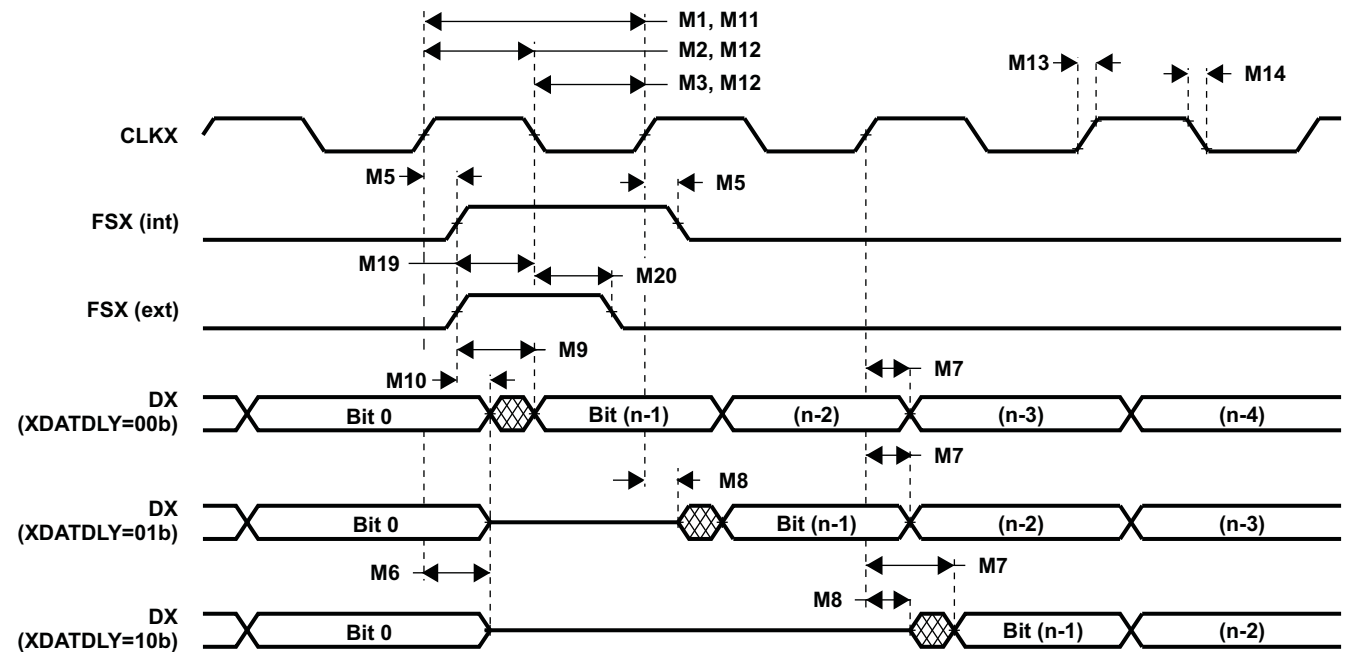

Figure 6-44. McBSP Transmit Timing

6.31.2 McBSP as SPI Master or Slave Timing

Table 6-52. McBSP as SPI Master or Slave Timing Requirements (CLKSTP = 10b, CLKXP = 0)⁽¹⁾

| NO. | | | MASTER | | SLAVE | | UNIT |
|-----|---------------------|--------------------------------------|--------|-----|---------|-----|------|
| | | | MIN | MAX | MIN | MAX | |
| M30 | $t_{su}(DRV-CKXL)$ | Setup time, DR valid before CLKX low | 30 | | 8P – 10 | | ns |
| M31 | $t_h(CKXL-DRV)$ | Hold time, DR valid after CLKX low | 1 | | 8P – 10 | | ns |
| M32 | $t_{su}(BFXL-CKXH)$ | Setup time, FSX low before CLKX high | | | 8P + 10 | | ns |
| M33 | $t_c(CKX)$ | Cycle time, CLKX | 2P | | 16P | | ns |

(1) 2P = 1/CLKG.
For all SPI slave modes, CLKX has to be minimum 8 CLKG cycles. Also, CLKG should be LSPCLK/2 by setting CLKSM = CLKGDV = 1. With maximum LSPCLK speed of 75 MHz, CLKX maximum frequency will be LSPCLK/16, that is 4.6875 MHz and P = 13.3 ns.

Table 6-53. McBSP as SPI Master or Slave Switching Characteristics (CLKSTP = 10b, CLKXP = 0)⁽¹⁾

| NO. | PARAMETER | MASTER | | SLAVE | | UNIT |
|-----|---------------------|--------|-----|--------|-----|------|
| | | MIN | MAX | MIN | MAX | |
| M24 | $t_h(CKXL-FXL)$ | | 2P | | | ns |
| M25 | $t_d(FXL-CKXH)$ | | P | | | ns |
| M28 | $t_{dis}(FXH-DXHZ)$ | 6 | | 6P + 6 | | ns |
| M29 | $t_d(FXL-DXV)$ | 6 | | 4P + 6 | | ns |

(1) 2P = 1/CLKG.
For all SPI slave modes, CLKX has to be minimum 8 CLKG cycles. Also, CLKG should be LSPCLK/2 by setting CLKSM = CLKGDV = 1. With maximum LSPCLK speed of 75 MHz, CLKX maximum frequency will be LSPCLK/16, that is 4.6875 MHz and P = 13.3 ns.

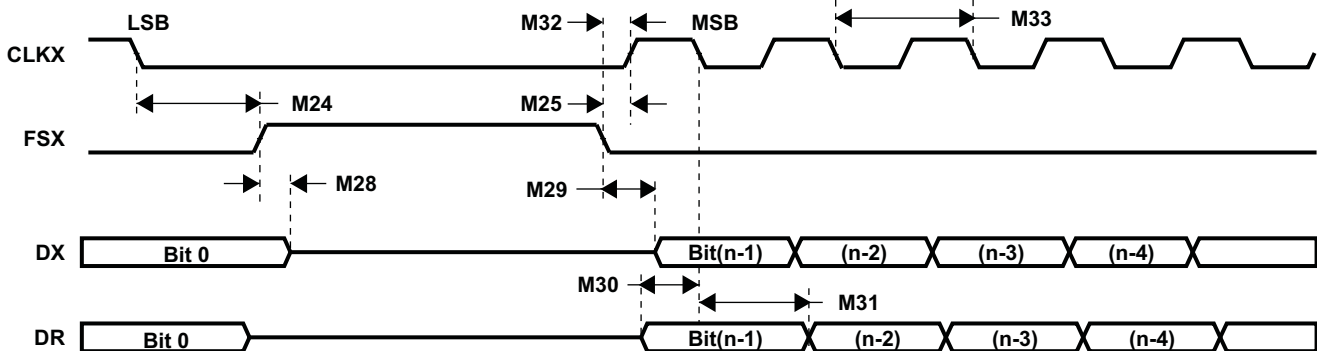

Figure 6-45. McBSP Timing as SPI Master or Slave: CLKSTP = 10b, CLKXP = 0

Table 6-54. McBSP as SPI Master or Slave Timing Requirements (CLKSTP = 11b, CLKXP = 0)⁽¹⁾

| NO. | | | MASTER | | SLAVE | | UNIT |
|-----|--------------------|---------------------------------------|--------|-----|----------|-----|------|
| | | | MIN | MAX | MIN | MAX | |
| M39 | $t_{su(DRV-CKXH)}$ | Setup time, DR valid before CLKX high | 30 | | 8P – 10 | | ns |
| M40 | $t_h(CKXH-DRV)$ | Hold time, DR valid after CLKX high | 1 | | 8P – 10 | | ns |
| M41 | $t_{su(FXL-CKXH)}$ | Setup time, FSX low before CLKX high | | | 16P + 10 | | ns |
| M42 | $t_c(CKX)$ | Cycle time, CLKX | 2P | | 16P | | ns |

(1) $2P = 1/CLKG$.
For all SPI slave modes, CLKX has to be minimum 8 CLKG cycles. Also CLKG should be LSPCLK/2 by setting CLKSM = CLKGDV = 1. With maximum LSPCLK speed of 75 MHz, CLKX maximum frequency will be LSPCLK/16, that is 4.6875 MHz and P = 13.3 ns.

Table 6-55. McBSP as SPI Master or Slave Switching Characteristics (CLKSTP = 11b, CLKXP = 0)⁽¹⁾

| NO. | PARAMETER | MASTER | | SLAVE | | UNIT |
|-----|----------------------|--------|-------|-------|--------|------|
| | | MIN | MAX | MIN | MAX | |
| M34 | $t_h(CKXL-FXL)$ | | P | | | ns |
| M35 | $t_d(FXL-CKXH)$ | | 2P | | | ns |
| M37 | $t_{dis}(CKXL-DXHZ)$ | | P + 6 | | 7P + 6 | ns |
| M38 | $t_d(FXL-DXV)$ | | 6 | | 4P + 6 | ns |

(1) $2P = 1/CLKG$.
For all SPI slave modes, CLKX has to be minimum 8 CLKG cycles. Also CLKG should be LSPCLK/2 by setting CLKSM = CLKGDV = 1. With maximum LSPCLK speed of 75 MHz, CLKX maximum frequency will be LSPCLK/16, that is 4.6875 MHz and P = 13.3 ns.

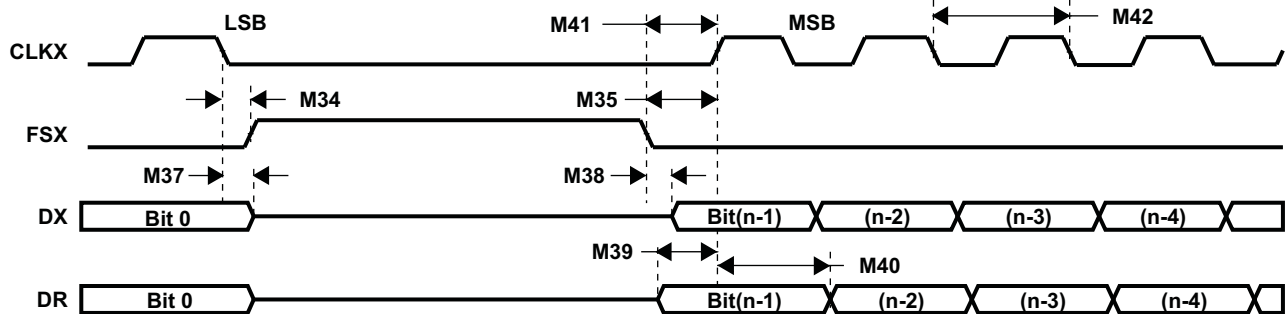

Figure 6-46. McBSP Timing as SPI Master or Slave: CLKSTP = 11b, CLKXP = 0

Table 6-56. McBSP as SPI Master or Slave Timing Requirements (CLKSTP = 10b, CLKXP = 1)⁽¹⁾

| NO. | | | MASTER | | SLAVE | | UNIT |
|-----|--------------------|---------------------------------------|--------|-----|---------|-----|------|
| | | | MIN | MAX | MIN | MAX | |
| M49 | $t_{su(DRV-CKXH)}$ | Setup time, DR valid before CLKX high | 30 | | 8P – 10 | | ns |
| M50 | $t_h(CKXH-DRV)$ | Hold time, DR valid after CLKX high | 1 | | 8P – 10 | | ns |
| M51 | $t_{su(FXL-CKXL)}$ | Setup time, FSX low before CLKX low | | | 8P + 10 | | ns |
| M52 | $t_c(CKX)$ | Cycle time, CLKX | 2P | | 16P | | ns |

(1) 2P = 1/CLKG.
For all SPI slave modes, CLKX has to be minimum 8 CLKG cycles. Also CLKG should be LSPCLK/2 by setting CLKSM = CLKGDV = 1. With maximum LSPCLK speed of 75 MHz, CLKX maximum frequency will be LSPCLK/16, that is 4.6875 MHz and P = 13.3 ns.

Table 6-57. McBSP as SPI Master or Slave Switching Characteristics (CLKSTP = 10b, CLKXP = 1)⁽¹⁾

| NO. | PARAMETER | MASTER | | SLAVE | | UNIT |
|-----|---------------------|--------|-----|--------|-----|------|
| | | MIN | MAX | MIN | MAX | |
| M43 | $t_h(CKXH-FXL)$ | 2P | | | | ns |
| M44 | $t_d(FXL-CKXL)$ | P | | | | ns |
| M47 | $t_{dis}(FXH-DXHZ)$ | 6 | | 6P + 6 | | ns |
| M48 | $t_d(FXL-DXV)$ | 6 | | 4P + 6 | | ns |

(1) 2P = 1/CLKG.
For all SPI slave modes, CLKX has to be minimum 8 CLKG cycles. Also CLKG should be LSPCLK/2 by setting CLKSM = CLKGDV = 1. With maximum LSPCLK speed of 75 MHz, CLKX maximum frequency will be LSPCLK/16, that is 4.6875 MHz and P = 13.3 ns.

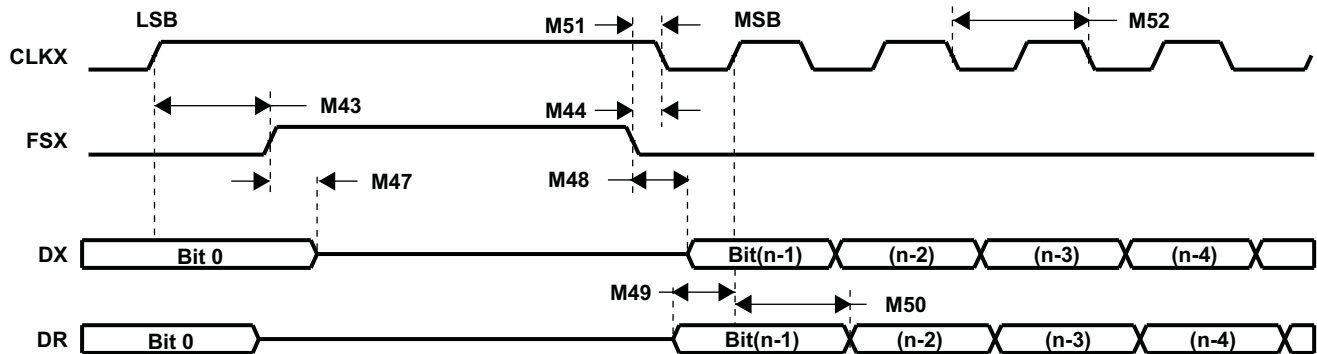

Figure 6-47. McBSP Timing as SPI Master or Slave: CLKSTP = 10b, CLKXP = 1

Table 6-58. McBSP as SPI Master or Slave Timing Requirements (CLKSTP = 11b, CLKXP = 1)⁽¹⁾

| NO. | | | MASTER | | SLAVE | | UNIT |
|-----|--------------------|--------------------------------------|--------|-----|----------|-----|------|
| | | | MIN | MAX | MIN | MAX | |
| M58 | $t_{su(DRV-CKXL)}$ | Setup time, DR valid before CLKX low | 30 | | 8P – 10 | | ns |
| M59 | $t_h(CKXL-DRV)$ | Hold time, DR valid after CLKX low | 1 | | 8P – 10 | | ns |
| M60 | $t_{su(FXL-CKXL)}$ | Setup time, FSX low before CLKX low | | | 16P + 10 | | ns |
| M61 | $t_c(CKX)$ | Cycle time, CLKX | 2P | | 16P | | ns |

(1) $2P = 1/CLKG$.
 For all SPI slave modes, CLKX has to be minimum 8 CLKG cycles. Also CLKG should be LSPCLK/2 by setting CLKSM = CLKGDV = 1. With maximum LSPCLK speed of 75 MHz, CLKX maximum frequency will be LSPCLK/16, that is 4.6875 MHz and P = 13.3 ns.

Table 6-59. McBSP as SPI Master or Slave Switching Characteristics (CLKSTP = 11b, CLKXP = 1)⁽¹⁾

| NO. | PARAMETER | MASTER | | SLAVE | | UNIT |
|-----|----------------------|--------|-------|--------|---------|------|
| | | MIN | MAX | MIN | MAX | |
| M53 | $t_h(CKXH-FXL)$ | | P | | | ns |
| M54 | $t_d(FXL-CKXL)$ | | 2P | | | ns |
| M55 | $t_d(CLKXH-DXV)$ | -2 | 0 | 3P + 6 | 5P + 20 | ns |
| M56 | $t_{dis}(CKXH-DXHZ)$ | | P + 6 | | 7P + 6 | ns |
| M57 | $t_d(FXL-DXV)$ | | 6 | | 4P + 6 | ns |

(1) $2P = 1/CLKG$.
 For all SPI slave modes, CLKX has to be minimum 8 CLKG cycles. Also CLKG should be LSPCLK/2 by setting CLKSM = CLKGDV = 1. With maximum LSPCLK speed of 75 MHz, CLKX maximum frequency will be LSPCLK/16, that is 4.6875 MHz and P = 13.3 ns.

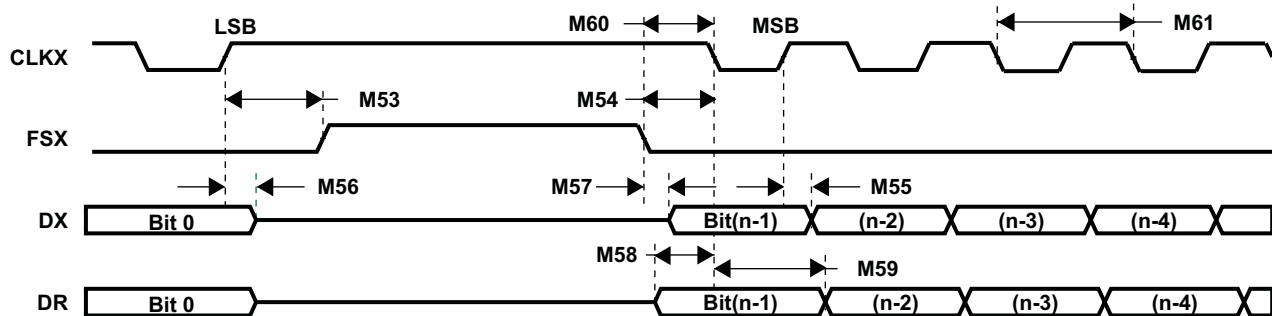

Figure 6-48. McBSP Timing as SPI Master or Slave: CLKSTP = 11b, CLKXP = 1

6.32 Flash Timing (F281x Only)

Table 6-60. Flash Endurance for A and S Temperature Material⁽¹⁾

| | | ERASE/PROGRAM TEMPERATURE | MIN | TYP | MAX | UNIT |
|------------------|--|---------------------------|----------------------|----------------------|-----|--------|
| N _f | Flash endurance for the array (Write/Erase cycles) | 0°C to 85°C (ambient) | 20000 ⁽²⁾ | 50000 ⁽²⁾ | | cycles |
| N _{OTP} | OTP endurance for the array (Write cycles) | 0°C to 85°C (ambient) | | | 1 | write |

(1) Write/erase operations outside of the temperature ranges indicated are not specified and may affect the endurance numbers.

(2) The Write/Erase cycle numbers of 20000 (MIN) and 50000 (TYP) are applicable **only** for silicon revision G. For older silicon revisions, the Write/Erase cycle numbers of 100 (MIN) and 1000 (TYP) are applicable.

Table 6-61. Flash Endurance for Q Temperature Material⁽¹⁾

| | | ERASE/PROGRAM TEMPERATURE | MIN | TYP | MAX | UNIT |
|------------------|--|---------------------------|----------------------|----------------------|-----|--------|
| N _f | Flash endurance for the array (Write/Erase cycles) | -40°C to 125°C (ambient) | 20000 ⁽²⁾ | 50000 ⁽²⁾ | | cycles |
| N _{OTP} | OTP endurance for the array (Write cycles) | -40°C to 125°C (ambient) | | | 1 | write |

(1) Write/erase operations outside of the temperature ranges indicated are not specified and may affect the endurance numbers.

(2) The Write/Erase cycle numbers of 20000 (MIN) and 50000 (TYP) are applicable **only** for silicon revision G. For older silicon revisions, the Write/Erase cycle numbers of 100 (MIN) and 1000 (TYP) are applicable.

Table 6-62. Flash Parameters at 150-MHz SYSCLKOUT⁽¹⁾

| PARAMETER | | | MIN | TYP | MAX | UNIT |
|---------------------------|--|-----------------------------------|-----|-----|-----|------|
| Program Time | 16-Bit Word | Using Flash API v1 ⁽²⁾ | | 35 | | μs |
| | | Using Flash API v2.10 | | 50 | | |
| | 8K Sector | Using Flash API v1 ⁽²⁾ | | 170 | | ms |
| | | Using Flash API v2.10 | | 250 | | |
| | 16K Sector | Using Flash API v1 ⁽²⁾ | | 320 | | ms |
| | | Using Flash API v2.10 | | 500 | | |
| Erase Time ⁽³⁾ | 8K Sector | | | 10 | | s |
| | 16K Sector | | | 11 | | |
| I _{DD3VFLP} | V _{DD3VFL} current consumption during the Erase/Program cycle | Erase | | 75 | | mA |
| | | Program | | 35 | | |
| I _{DDP} | V _{DD} current consumption during Erase/Program cycle | | | 140 | | mA |
| I _{DDIOP} | V _{DDIO} current consumption during Erase/Program cycle | | | 20 | | mA |

(1) Typical parameters as seen at room temperature including function call overhead, with all peripherals off.

(2) Flash API v1.00 is useable on rev. C silicon only.

(3) The on-chip flash memory is in an erased state when the device is shipped from TI. As such, erasing the flash memory is not required prior to programming, when programming the device for the first time. However, the erase operation is needed on all subsequent programming operations.

Table 6-63. Flash/OTP Access Timing

| PARAMETER | | MIN | MAX | UNIT |
|--------------|--------------------------|-----|-----|------|
| $t_{a(fp)}$ | Paged Flash access time | 36 | | ns |
| $t_{a(fr)}$ | Random Flash access time | 36 | | ns |
| $t_{a(OTP)}$ | OTP access time | 60 | | ns |

Table 6-64. Minimum Required Flash Wait States at Different Frequencies (F281x devices)

| SYSCLKOUT (MHz) | SYSCLKOUT (ns) | PAGE WAIT STATE ⁽¹⁾ | RANDOM WAIT STATE ^{(1) (2)} | OTP |
|-----------------|----------------|--------------------------------|--------------------------------------|-----|
| 150 | 6.67 | 5 | 5 | 8 |
| 120 | 8.33 | 4 | 4 | 7 |
| 100 | 10 | 3 | 3 | 5 |
| 75 | 13.33 | 2 | 2 | 4 |
| 50 | 20 | 1 | 1 | 2 |
| 30 | 33.33 | 1 | 1 | 1 |
| 25 | 40 | 0 | 1 | 1 |
| 15 | 66.67 | 0 | 1 | 1 |
| 4 | 250 | 0 | 1 | 1 |

(1) Formulas to compute page wait state and random wait state:

$$\text{Flash Page Wait State} = \left\lceil \left[\left(\frac{t_{a(fp)}}{t_{c(SCO)}} \right) - 1 \right] \right\rceil \text{ (round up to the next highest integer, or 0, whichever is larger)}$$

$$\text{Flash Random Wait State} = \left\lceil \left[\left(\frac{t_{a(fr)}}{t_{c(SCO)}} \right) - 1 \right] \right\rceil \text{ (round up to the next highest integer, or 1, whichever is larger)}$$

$$\text{OTP Wait State} = \left\lceil \left[\left(\frac{t_{a(OTP)}}{t_{c(SCO)}} \right) - 1 \right] \right\rceil \text{ (round up to the next highest integer, or 1, whichever is larger)}$$

(2) Random wait state must be greater than or equal to 1.

6.33 ROM Timing (C281x only)

Table 6-65. ROM Access Timing

| PARAMETER | | MIN | MAX | UNIT |
|--------------|---|-----|-----|------|
| $t_{a(rp)}$ | Paged ROM access time | 23 | | ns |
| $t_{a(rr)}$ | Random ROM access time | 23 | | ns |
| $t_{a(ROM)}$ | ROM (OTP area) access time ⁽¹⁾ | 60 | | ns |

(1) In C281x devices, a 1K x 16 ROM block replaces the OTP block found in Flash devices.

Table 6-66. Minimum Required ROM Wait States at Different Frequencies (C281x devices)

| SYSCLKOUT (MHz) | SYSCLKOUT (ns) | PAGE WAIT STATE ⁽¹⁾ | RANDOM WAIT STATE ^{(1) (2)} |
|-----------------|----------------|--------------------------------|--------------------------------------|
| 150 | 6.67 | 3 | 3 |
| 120 | 8.33 | 2 | 2 |
| 100 | 10 | 2 | 2 |
| 75 | 13.33 | 1 | 1 |
| 50 | 20 | 1 | 1 |
| 30 | 33.33 | 0 | 1 |
| 25 | 40 | 0 | 1 |
| 15 | 66.67 | 0 | 1 |
| 4 | 250 | 0 | 1 |

(1) Formulas to compute page wait state and random wait state:

$$\text{ROM Page Wait State} = \left\lceil \left(\frac{t_{a(rp)}}{t_{c(SCO)}} \right) - 1 \right\rceil \quad (\text{round up to the next highest integer, or 0, whichever is larger})$$

$$\text{ROM Random Wait State} = \left\lceil \left(\frac{t_{a(rr)}}{t_{c(SCO)}} \right) - 1 \right\rceil \quad (\text{round up to the next highest integer, or 1, whichever is larger})$$

(2) Random wait state must be greater than or equal to 1.

6.34 Migrating From F281x Devices to C281x Devices

The migration issues to be considered while migrating from the F281x devices to C281x devices are as follows:

- The 1K OTP memory available in F281x devices has been replaced by 1K ROM in C281x devices.
- Power sequencing is not needed for C281x devices. In other words, 3.3-V and 1.8-V (or 1.9-V) can ramp together. C281x can also be used on boards that have F281x power sequencing implemented; however, if the 1.8-V (or 1.9-V) rail lags the 3.3-V rail, the GPIO pins are undefined until the 1.8-V rail reaches at least 1 V.
- Current consumption differs for F281x and C281x devices for all four possible modes. See the appropriate electrical section for exact numbers.
- The V_{DD3VFL} pin is the 3.3-V flash core power pin in F281x devices but is a V_{DDIO} pin in C281x devices.
- F281x and C281x devices are pin-compatible and code-compatible; however, they are electrically different with different EMI/ESD profiles. Before ramping production with C281x devices, evaluate performance of the hardware design with both devices.
- Addresses 0x3D 7BFC through 0x3D 7BFF in the OTP and addresses 0x3F 7FF2 through 0x3F 7FF5 in the main ROM array are reserved for ROM part-specific information and are not available for user applications.
- The ADC module in C281x devices can operate at 24.9k bias on ADCRESEXT pin for the full range 1–25 MHz. While migrating the F281x designs to C281x, use a 24.9k resistor for biasing the ADC.
- The paged and random wait-state specifications for the flash and ROM parts are different. While migrating from flash to ROM parts, the same wait-state values must be used for best performance compatibility (for example, in applications that use software delay loops or where precise interrupt latencies are critical).
- The PART-ID register value is different for Flash and ROM parts.

For errata applicable to 281x devices, see the *TMS320F2810*, *TMS320F2811*, *TMS320F2812*, *TMS320C2810*, *TMS320C2811*, *TMS320C2812 DSP Silicon Errata* (literature number [SPRZ193](#)).

7 Revision History

This data sheet revision history highlights the technical changes made to the SPRS174S device-specific data sheet to make it an SPRS174T revision.

Scope: See table below.

| LOCATION | ADDITIONS, DELETIONS, AND MODIFICATIONS |
|-----------------------------|---|
| Section 1.1 | Features: <ul style="list-style-type: none"> • Added "Endianness: Little Endian" feature |
| Table 6-4 | Recommended "Low-Dropout Regulators": <ul style="list-style-type: none"> • Replaced TPS767D301 with TPS75005 • Added DESCRIPTION column |
| Table 6-59 | McBSP as SPI Master or Slave Switching Characteristics (CLKSTP = 11b, CLKXP = 1): <ul style="list-style-type: none"> • Added parameter M55, $t_{d(CLKXH-DXV)}$, Delay time, CLKX high to DX valid |
| Table 6-62 | Flash Parameters at 150-MHz SYSCLKOUT: <ul style="list-style-type: none"> • Added footnote about flash memory being in an erased state when the device is shipped |

8 Mechanical Data

Table 8-1 through Table 8-4 provide the thermal resistance characteristics for the various packages.

Table 8-1. Thermal Resistance Characteristics for 179-Ball GHH

| PARAMETER | 179-GHH PACKAGE | UNIT |
|---------------|-----------------|------|
| Ψ_{sJT} | 0.658 | °C/W |
| Θ_{JA} | 42.57 | °C/W |
| Θ_{JC} | 16.08 | °C/W |

Table 8-2. Thermal Resistance Characteristics for 179-Ball ZHH

| PARAMETER | 179-ZHH PACKAGE | UNIT |
|---------------|-----------------|------|
| Ψ_{sJT} | 0.658 | °C/W |
| Θ_{JA} | 42.57 | °C/W |
| Θ_{JC} | 16.08 | °C/W |

Table 8-3. Thermal Resistance Characteristics for 176-Pin PGF

| PARAMETER | 176-PGF PACKAGE | UNIT |
|---------------|-----------------|------|
| Ψ_{sJT} | 0.247 | °C/W |
| Θ_{JA} | 41.88 | °C/W |
| Θ_{JC} | 9.73 | °C/W |

Table 8-4. Thermal Resistance Characteristics for 128-Pin PBK

| PARAMETER | 128-PBK PACKAGE | UNIT |
|---------------|-----------------|------|
| Ψ_{sJT} | 0.271 | °C/W |
| Θ_{JA} | 41.65 | °C/W |
| Θ_{JC} | 10.76 | °C/W |

The following mechanical package diagram(s) reflect the most current released mechanical data available for the designated device(s).

PACKAGING INFORMATION

| Orderable Device | Status (1) | Package Type | Package Drawing | Pins | Package Qty | Eco Plan (2) | Lead/Ball Finish (6) | MSL Peak Temp (3) | Op Temp (°C) | Device Marking (4/5) | Samples |
|-------------------|---------------|------------------|-----------------|------|-------------|-------------------------|-------------------------|----------------------|--------------|-------------------------|-------------------------|
| TMS320C2810PBKA | ACTIVE | LQFP | PBK | 128 | | TBD | Call TI | Call TI | -40 to 85 | | Samples |
| TMS320C2810PBKQ | ACTIVE | LQFP | PBK | 128 | | TBD | Call TI | Call TI | -40 to 125 | | Samples |
| TMS320C2811PBKA | ACTIVE | LQFP | PBK | 128 | | TBD | Call TI | Call TI | -40 to 85 | | Samples |
| TMS320C2811PBKQ | ACTIVE | LQFP | PBK | 128 | | TBD | Call TI | Call TI | -40 to 125 | | Samples |
| TMS320C2812PGFA | ACTIVE | LQFP | PGF | 176 | | TBD | Call TI | Call TI | -40 to 85 | | Samples |
| TMS320F2810PBKA | ACTIVE | LQFP | PBK | 128 | 90 | Green (RoHS & no Sb/Br) | CU NIPDAU | Level-2-260C-1 YEAR | -40 to 85 | 320F2810PBKA TMS | Samples |
| TMS320F2810PBKQ | ACTIVE | LQFP | PBK | 128 | 90 | Green (RoHS & no Sb/Br) | CU NIPDAU | Level-2-260C-1 YEAR | -40 to 125 | 320F2810PBKQ TMS | Samples |
| TMS320F2810PBKQR | ACTIVE | LQFP | PBK | 128 | 1000 | Green (RoHS & no Sb/Br) | CU NIPDAU | Level-2-260C-1 YEAR | -40 to 125 | 320F2810PBKQ TMS | Samples |
| TMS320F2810PBKS | ACTIVE | LQFP | PBK | 128 | 90 | Green (RoHS & no Sb/Br) | CU NIPDAU | Level-2-260C-1 YEAR | -40 to 125 | 320F2810PBKS TMS | Samples |
| TMS320F2811PBKA | ACTIVE | LQFP | PBK | 128 | 90 | Green (RoHS & no Sb/Br) | CU NIPDAU | Level-2-260C-1 YEAR | -40 to 85 | 320F2811PBKA TMS | Samples |
| TMS320F2811PBKQ | ACTIVE | LQFP | PBK | 128 | 90 | Green (RoHS & no Sb/Br) | CU NIPDAU | Level-2-260C-1 YEAR | -40 to 125 | 320F2811PBKQ TMS | Samples |
| TMS320F2811PBKS | ACTIVE | LQFP | PBK | 128 | 90 | Green (RoHS & no Sb/Br) | CU NIPDAU | Level-2-260C-1 YEAR | -40 to 125 | 320F2811PBKS TMS | Samples |
| TMS320F2812GHHA | ACTIVE | BGA MICROSTAR | GHH | 179 | 160 | TBD | SNPB | Level-3-220C-168 HR | -40 to 85 | 320F2812GHHA TMS | Samples |
| TMS320F2812GHHAR | ACTIVE | BGA MICROSTAR | GHH | 179 | 1000 | TBD | SNPB | Level-3-220C-168 HR | -40 to 85 | 320F2812GHHA TMS | Samples |
| TMS320F2812GHHQ | ACTIVE | BGA MICROSTAR | GHH | 179 | 160 | TBD | SNPB | Level-3-220C-168 HR | -40 to 125 | 320F2812GHHQ TMS | Samples |
| TMS320F2812GHHS | ACTIVE | BGA MICROSTAR | GHH | 179 | 160 | TBD | SNPB | Level-3-220C-168 HR | -40 to 125 | 320F2812GHHS TMS | Samples |
| TMS320F2812PGFA | ACTIVE | LQFP | PGF | 176 | 40 | Green (RoHS & no Sb/Br) | CU NIPDAU | Level-3-260C-168 HR | -40 to 85 | 320F2812PGFA TMS | Samples |
| TMS320F2812PGFAG4 | ACTIVE | LQFP | PGF | 176 | 40 | Green (RoHS & no Sb/Br) | CU NIPDAU | Level-3-260C-168 HR | -40 to 85 | 320F2812PGFA TMS | Samples |

| Orderable Device | Status (1) | Package Type | Package Drawing | Pins | Package Qty | Eco Plan (2) | Lead/Ball Finish (6) | MSL Peak Temp (3) | Op Temp (°C) | Device Marking (4/5) | Samples |
|------------------|---------------|------------------|-----------------|------|-------------|-------------------------|-------------------------|----------------------|--------------|-------------------------|-------------------------|
| TMS320F2812PGFQ | ACTIVE | LQFP | PGF | 176 | 40 | Green (RoHS & no Sb/Br) | CU NIPDAU | Level-3-260C-168 HR | -40 to 125 | 320F2812PGFQ TMS | Samples |
| TMS320F2812PGFS | ACTIVE | LQFP | PGF | 176 | 40 | Green (RoHS & no Sb/Br) | CU NIPDAU | Level-3-260C-168 HR | -40 to 125 | 320F2812PGFS TMS | Samples |
| TMS320F2812ZHHA | ACTIVE | BGA MICROSTAR | ZHH | 179 | 160 | Green (RoHS & no Sb/Br) | SNAGCU | Level-3-260C-168 HR | -40 to 85 | 320F2812ZHHA TMS | Samples |
| TMS320F2812ZHAR | ACTIVE | BGA MICROSTAR | ZHH | 179 | 1000 | Green (RoHS & no Sb/Br) | SNAGCU | Level-3-260C-168 HR | -40 to 85 | 320F2812ZHHA TMS | Samples |
| TMS320F2812ZHHS | ACTIVE | BGA MICROSTAR | ZHH | 179 | 160 | Green (RoHS & no Sb/Br) | SNAGCU | Level-3-260C-168 HR | -40 to 125 | 320F2812ZHHS TMS | Samples |

(1) The marketing status values are defined as follows:

ACTIVE: Product device recommended for new designs.

LIFEBUY: TI has announced that the device will be discontinued, and a lifetime-buy period is in effect.

NRND: Not recommended for new designs. Device is in production to support existing customers, but TI does not recommend using this part in a new design.

PREVIEW: Device has been announced but is not in production. Samples may or may not be available.

OBSELETE: TI has discontinued the production of the device.

(2) Eco Plan - The planned eco-friendly classification: Pb-Free (RoHS), Pb-Free (RoHS Exempt), or Green (RoHS & no Sb/Br) - please check <http://www.ti.com/productcontent> for the latest availability information and additional product content details.

TBD: The Pb-Free/Green conversion plan has not been defined.

Pb-Free (RoHS): TI's terms "Lead-Free" or "Pb-Free" mean semiconductor products that are compatible with the current RoHS requirements for all 6 substances, including the requirement that lead not exceed 0.1% by weight in homogeneous materials. Where designed to be soldered at high temperatures, TI Pb-Free products are suitable for use in specified lead-free processes.

Pb-Free (RoHS Exempt): This component has a RoHS exemption for either 1) lead-based flip-chip solder bumps used between the die and package, or 2) lead-based die adhesive used between the die and leadframe. The component is otherwise considered Pb-Free (RoHS compatible) as defined above.

Green (RoHS & no Sb/Br): TI defines "Green" to mean Pb-Free (RoHS compatible), and free of Bromine (Br) and Antimony (Sb) based flame retardants (Br or Sb do not exceed 0.1% by weight in homogeneous material)

(3) MSL, Peak Temp. - The Moisture Sensitivity Level rating according to the JEDEC industry standard classifications, and peak solder temperature.

(4) There may be additional marking, which relates to the logo, the lot trace code information, or the environmental category on the device.

(5) Multiple Device Markings will be inside parentheses. Only one Device Marking contained in parentheses and separated by a "~" will appear on a device. If a line is indented then it is a continuation of the previous line and the two combined represent the entire Device Marking for that device.

(6) Lead/Ball Finish - Orderable Devices may have multiple material finish options. Finish options are separated by a vertical ruled line. Lead/Ball Finish values may wrap to two lines if the finish value exceeds the maximum column width.

Important Information and Disclaimer: The information provided on this page represents TI's knowledge and belief as of the date that it is provided. TI bases its knowledge and belief on information provided by third parties, and makes no representation or warranty as to the accuracy of such information. Efforts are underway to better integrate information from third parties. TI has taken and continues to take reasonable steps to provide representative and accurate information but may not have conducted destructive testing or chemical analysis on incoming materials and chemicals. TI and TI suppliers consider certain information to be proprietary, and thus CAS numbers and other limited information may not be available for release.

In no event shall TI's liability arising out of such information exceed the total purchase price of the TI part(s) at issue in this document sold by TI to Customer on an annual basis.

OTHER QUALIFIED VERSIONS OF TMS320F2812 :

- Catalog: [SM320F2812](#)
- Enhanced Product: [SM320F2812-EP](#)
- Military: [SMJ320F2812](#)

NOTE: Qualified Version Definitions:

- Catalog - TI's standard catalog product
- Enhanced Product - Supports Defense, Aerospace and Medical Applications
- Military - QML certified for Military and Defense Applications

MECHANICAL DATA

ZHH (S-PBGA-N179)

PLASTIC BALL GRID ARRAY

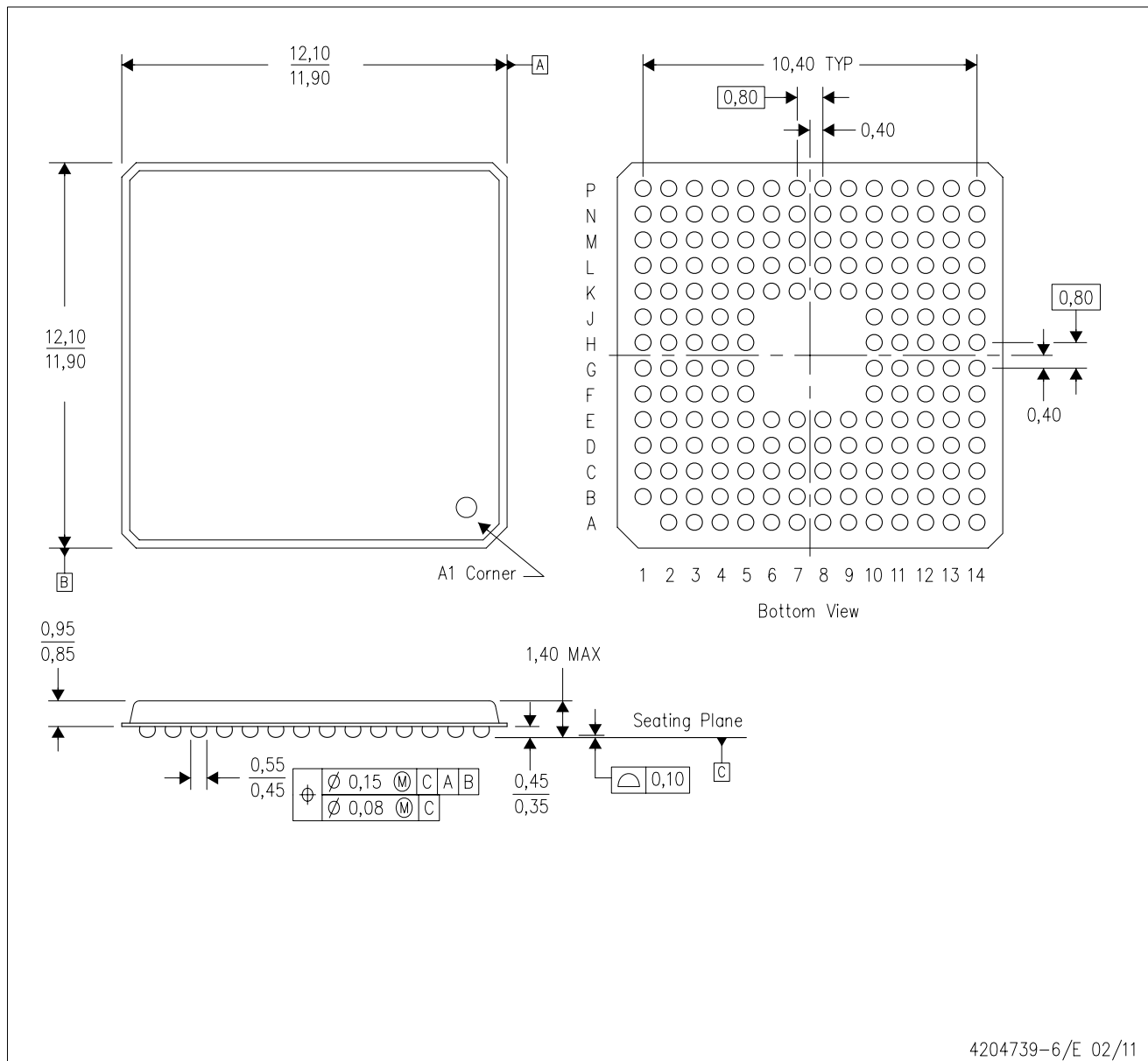

- NOTES:
- A. All linear dimensions are in millimeters.
 - B. This drawing is subject to change without notice.
 - C. MicroStar BGA configuration.
 - D. This is a Pb-free solder ball design.

MicroStar is a trademark of Texas Instruments.

MECHANICAL DATA

PBK (S-PQFP-G120)

PLASTIC QUAD FLATPACK

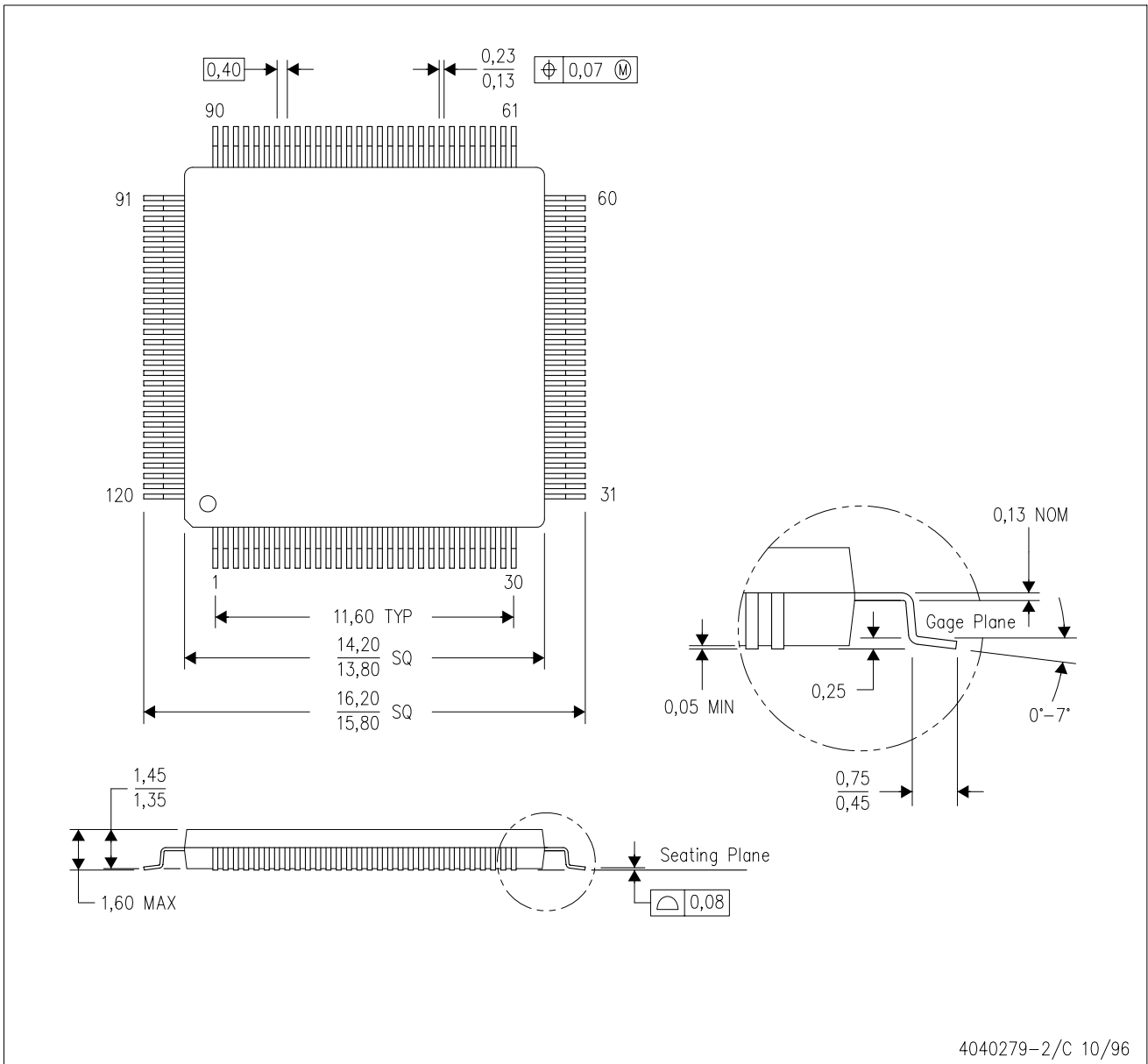

- NOTES:
- A. All linear dimensions are in millimeters.
 - B. This drawing is subject to change without notice.
 - C. Falls within JEDEC MS-026

MECHANICAL DATA

PBK (S-PQFP-G128)

PLASTIC QUAD FLATPACK

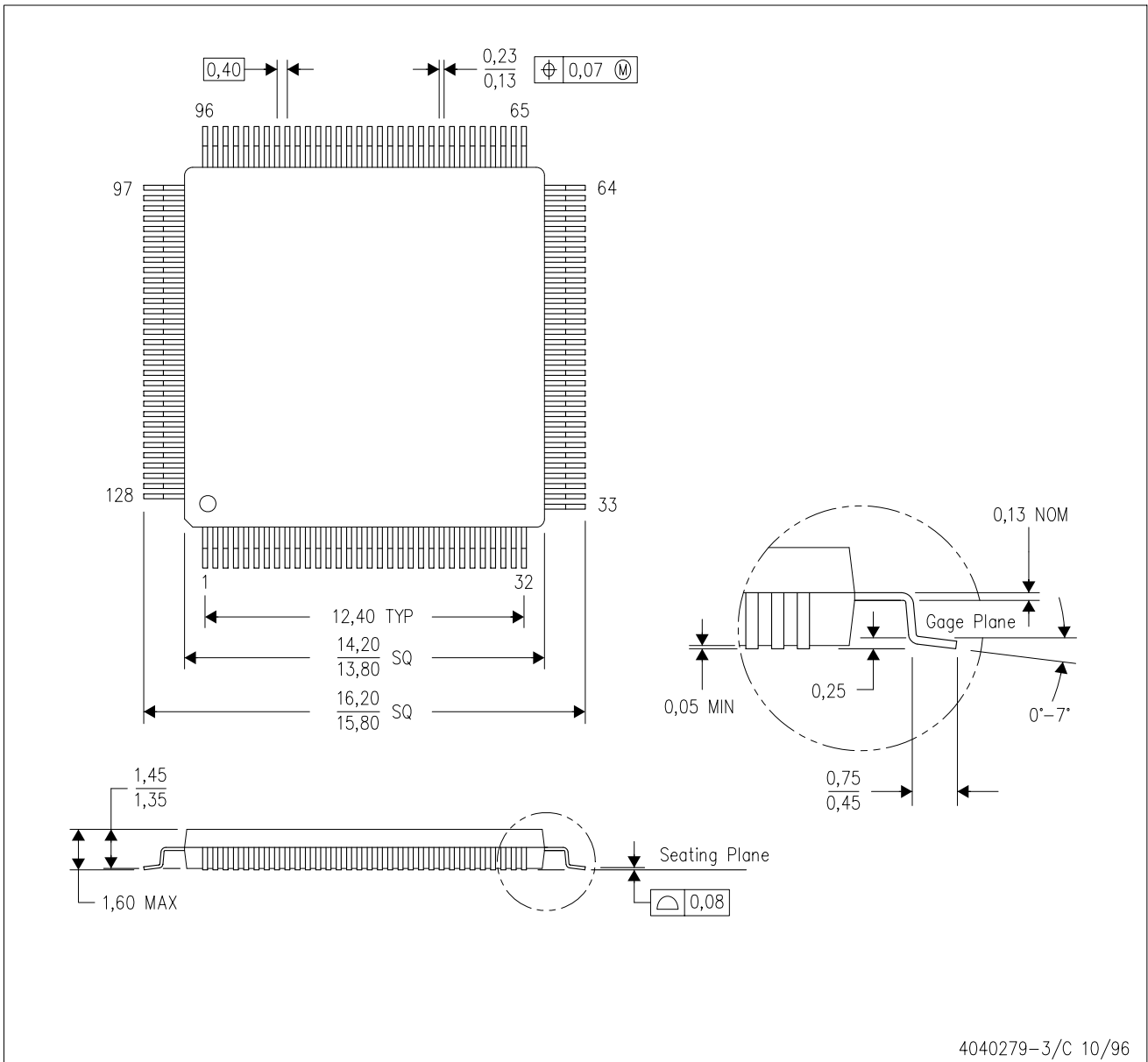

- NOTES:
- A. All linear dimensions are in millimeters.
 - B. This drawing is subject to change without notice.
 - C. Falls within JEDEC MS-026

PBK (S-PQFP-G128)

PLASTIC QUAD FLAT PACK

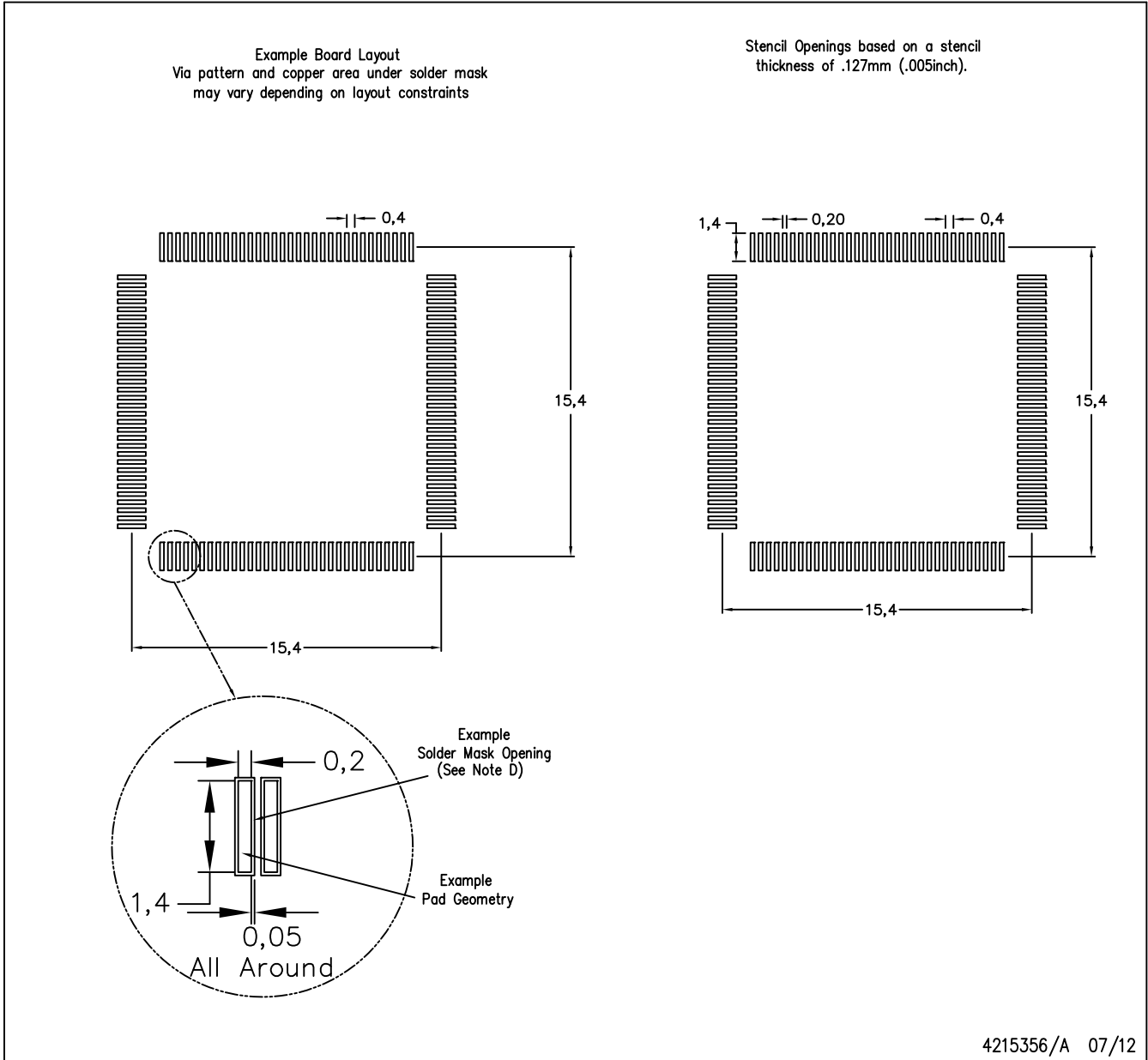

- NOTES:
- A. All linear dimensions are in millimeters.
 - B. This drawing is subject to change without notice.
 - C. Laser cutting apertures with trapezoidal walls and also rounding corners will offer better paste release. Customers should contact their board assembly site for stencil design recommendations. Example stencil metal load solder paste. Refer to IPC-7525 for other stencil recommendations.
 - D. Customers should contact their board fabrication site for solder mask tolerances between and around signal pads.

PGF (S-PQFP-G176)

PLASTIC QUAD FLATPACK

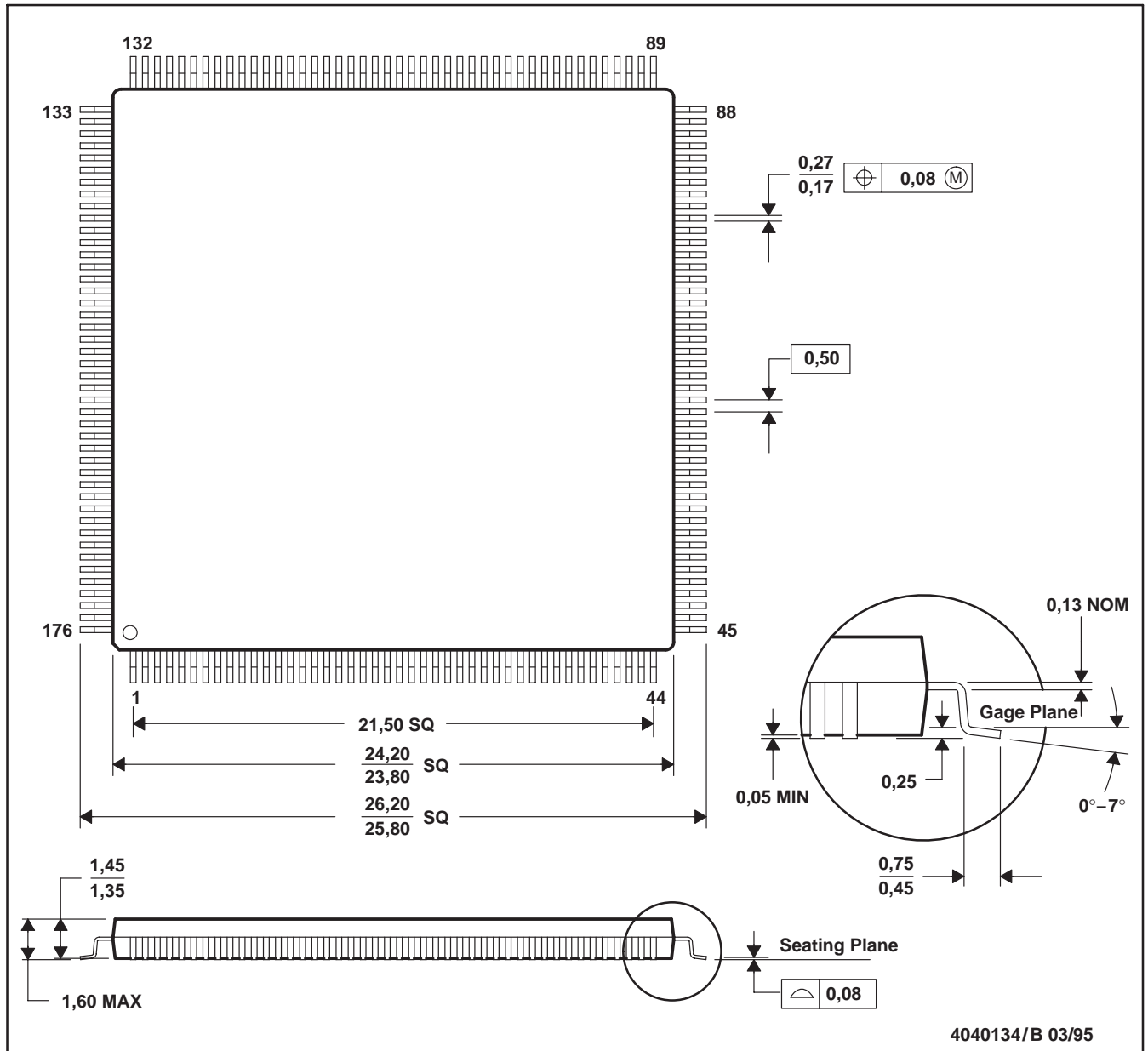

- NOTES: A. All linear dimensions are in millimeters.
 B. This drawing is subject to change without notice.
 C. Falls within JEDEC MO-136

IMPORTANT NOTICE

Texas Instruments Incorporated and its subsidiaries (TI) reserve the right to make corrections, enhancements, improvements and other changes to its semiconductor products and services per JESD46, latest issue, and to discontinue any product or service per JESD48, latest issue. Buyers should obtain the latest relevant information before placing orders and should verify that such information is current and complete. All semiconductor products (also referred to herein as "components") are sold subject to TI's terms and conditions of sale supplied at the time of order acknowledgment.

TI warrants performance of its components to the specifications applicable at the time of sale, in accordance with the warranty in TI's terms and conditions of sale of semiconductor products. Testing and other quality control techniques are used to the extent TI deems necessary to support this warranty. Except where mandated by applicable law, testing of all parameters of each component is not necessarily performed.

TI assumes no liability for applications assistance or the design of Buyers' products. Buyers are responsible for their products and applications using TI components. To minimize the risks associated with Buyers' products and applications, Buyers should provide adequate design and operating safeguards.

TI does not warrant or represent that any license, either express or implied, is granted under any patent right, copyright, mask work right, or other intellectual property right relating to any combination, machine, or process in which TI components or services are used. Information published by TI regarding third-party products or services does not constitute a license to use such products or services or a warranty or endorsement thereof. Use of such information may require a license from a third party under the patents or other intellectual property of the third party, or a license from TI under the patents or other intellectual property of TI.

Reproduction of significant portions of TI information in TI data books or data sheets is permissible only if reproduction is without alteration and is accompanied by all associated warranties, conditions, limitations, and notices. TI is not responsible or liable for such altered documentation. Information of third parties may be subject to additional restrictions.

Resale of TI components or services with statements different from or beyond the parameters stated by TI for that component or service voids all express and any implied warranties for the associated TI component or service and is an unfair and deceptive business practice. TI is not responsible or liable for any such statements.

Buyer acknowledges and agrees that it is solely responsible for compliance with all legal, regulatory and safety-related requirements concerning its products, and any use of TI components in its applications, notwithstanding any applications-related information or support that may be provided by TI. Buyer represents and agrees that it has all the necessary expertise to create and implement safeguards which anticipate dangerous consequences of failures, monitor failures and their consequences, lessen the likelihood of failures that might cause harm and take appropriate remedial actions. Buyer will fully indemnify TI and its representatives against any damages arising out of the use of any TI components in safety-critical applications.

In some cases, TI components may be promoted specifically to facilitate safety-related applications. With such components, TI's goal is to help enable customers to design and create their own end-product solutions that meet applicable functional safety standards and requirements. Nonetheless, such components are subject to these terms.

No TI components are authorized for use in FDA Class III (or similar life-critical medical equipment) unless authorized officers of the parties have executed a special agreement specifically governing such use.

Only those TI components which TI has specifically designated as military grade or "enhanced plastic" are designed and intended for use in military/aerospace applications or environments. Buyer acknowledges and agrees that any military or aerospace use of TI components which have **not** been so designated is solely at the Buyer's risk, and that Buyer is solely responsible for compliance with all legal and regulatory requirements in connection with such use.

TI has specifically designated certain components as meeting ISO/TS16949 requirements, mainly for automotive use. In any case of use of non-designated products, TI will not be responsible for any failure to meet ISO/TS16949.

Products

| | |
|------------------------------|--|
| Audio | www.ti.com/audio |
| Amplifiers | amplifier.ti.com |
| Data Converters | dataconverter.ti.com |
| DLP® Products | www.dlp.com |
| DSP | dsp.ti.com |
| Clocks and Timers | www.ti.com/clocks |
| Interface | interface.ti.com |
| Logic | logic.ti.com |
| Power Mgmt | power.ti.com |
| Microcontrollers | microcontroller.ti.com |
| RFID | www.ti-rfid.com |
| OMAP Applications Processors | www.ti.com/omap |
| Wireless Connectivity | www.ti.com/wirelessconnectivity |

Applications

| | |
|-------------------------------|--|
| Automotive and Transportation | www.ti.com/automotive |
| Communications and Telecom | www.ti.com/communications |
| Computers and Peripherals | www.ti.com/computers |
| Consumer Electronics | www.ti.com/consumer-apps |
| Energy and Lighting | www.ti.com/energy |
| Industrial | www.ti.com/industrial |
| Medical | www.ti.com/medical |
| Security | www.ti.com/security |
| Space, Avionics and Defense | www.ti.com/space-avionics-defense |
| Video and Imaging | www.ti.com/video |

TI E2E Community

e2e.ti.com

Looking for pricing, stock, or lifecycle information?

Click below to explore more details on WIN SOURCE:

 [View TMS320F2812GHHQ on WIN SOURCE](#)

 [Texas Instruments](#) Information

Optimize Your Supply Chain with WIN SOURCE Solutions

-  Global Sourcing Solution
-  Obsolete Management
-  Cost Control Management
-  Shortage Management
-  Alternative Solution
-  Excess Inventory Management