



THE DATASHEET OF LP395Z/NOPB



LP395 Ultra Reliable Power Transistor

Check for Samples: [LP395](#)

FEATURES

- **Internal Thermal Limiting**
- **Internal Current and Power Limiting**
- **Specified 100 mA Output Current**
- **0.5 μ A Typical Base Current**
- **Directly Interfaces with TTL or CMOS**
- **+36 Volts On Base Causes No Damage**
- **2 μ s Switching Time**

DESCRIPTION

The LP395 is a fast monolithic transistor with complete overload protection. This very high gain transistor has included on the chip, current limiting, power limiting, and thermal overload protection, making it difficult to destroy from almost any type of overload. Available in an epoxy TO-92 transistor package this device is specified to deliver 100 mA.

Thermal limiting at the chip level, a feature not available in discrete designs, provides comprehensive protection against overload. Excessive power dissipation or inadequate heat sinking causes the thermal limiting circuitry to turn off the device preventing excessive die temperature.

The LP395 offers a significant increase in reliability while simplifying protection circuitry. It is especially attractive as a small incandescent lamp or solenoid driver because of its low drive requirements and blowout-proof design.

Connection Diagram

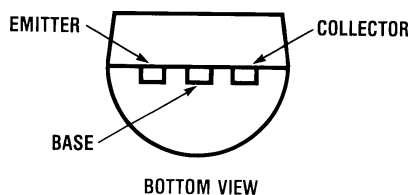

Figure 1. TO-92 Package
See NS Package LP0003A

The LP395 is easy to use and only a few precautions need be observed. Excessive collector to emitter voltage can destroy the LP395 as with any transistor. When the device is used as an emitter follower with a low source impedance, it is necessary to insert a 4.7 k Ω resistor in series with the base lead to prevent possible emitter follower oscillations. Also since it has good high frequency response, supply by-passing is recommended.

Areas where the LP395 differs from a standard NPN transistor are in saturation voltage, leakage (quiescent) current and in base current. Since the internal protection circuitry requires voltage and current to function, the minimum voltage across the device in the on condition (saturated) is typically 1.6 Volts, while in the off condition the quiescent (leakage) current is typically 200 μ A. Base current in this device flows out of the base lead, rather than into the base as is the case with conventional NPN transistors. Also the base can be driven positive up to 36 Volts without damage, but will draw current if driven negative more than 0.6 Volts. Additionally, if the base lead is left open, the LP395 will turn on.

The LP395 is a low-power version of the 1-Amp LM195/LM295/LM395 Ultra Reliable Power Transistor.

The LP395 is rated for operation over a -40°C to $+125^{\circ}\text{C}$ range.

Typical Applications

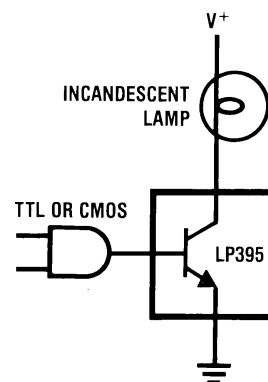

Figure 2. Fully Protected Lamp Driver



Please be aware that an important notice concerning availability, standard warranty, and use in critical applications of Texas Instruments semiconductor products and disclaimers thereto appears at the end of this data sheet.

All trademarks are the property of their respective owners.



These devices have limited built-in ESD protection. The leads should be shorted together or the device placed in conductive foam during storage or handling to prevent electrostatic damage to the MOS gates.

ABSOLUTE MAXIMUM RATINGS⁽¹⁾

Collector to Emitter Voltage	36V
Collector to Base Voltage	36V
Base to Emitter Voltage (Forward)	36V
Base to Emitter Voltage (Reverse)	10V
Base to Emitter Current (Reverse)	20 mA
Collector Current Limit	Internally Limited
Power Dissipation	Internally Limited
Operating Temperature Range	-40°C to +125°C
Storage Temperature Range	-65°C to +150°C
Lead Temp. (Soldering, 10 seconds)	260°C

(1) Absolute Maximum Ratings indicate limits beyond which damage to the device may occur. Operating Ratings indicate conditions for which the device is functional, but do not ensure specific performance limits.

ELECTRICAL CHARACTERISTICS

Symbol	Parameter	Conditions	Typical	Tested Limit ⁽¹⁾	Design Limit ⁽²⁾	Units (Limit)
V_{CE}	Collector to Emitter Operating Voltage	$0.5 \text{ mA} \leq I_C \leq 100 \text{ mA}$		36	36 ⁽³⁾	V(Max)
I_{CL}	Collector Current Limit ⁽⁴⁾	$V_{BE} = 2V, V_{CE} = 36V$	45	25	20	mA(Min)
		$V_{BE} = 2V, V_{CE} = 15V$	90	60	50	mA(Min)
		$V_{BE} = 2V, 2V \leq V_{CE} \leq 6V$	130	100	100	mA(Min)
I_B	Base Current	$0 \leq I_C \leq 100 \text{ mA}$	-0.3	-2.0	-2.5	$\mu\text{A}(\text{Max})$
I_Q	Quiescent Current	$V_{BE} = 0V, 0 \leq V_{CE} \leq 36V$	0.24	0.50	0.60	mA(Max)
$V_{CE(\text{SAT})}$	Saturation Voltage	$V_{BE} = 2V, I_C = 100 \text{ mA}$	1.82	2.00	2.10	V(Max)
BV_{BE}	Base to Emitter Break-down Voltage ⁽⁴⁾	$0 \leq V_{CE} \leq 36V, I_B = 2 \mu\text{A}$		36	36	V(Min)
V_{BE}	Base to Emitter Voltage ⁽⁵⁾	$I_C = 5 \text{ mA}$	0.69	0.79	0.90	V(Max)
		$I_C = 100 \text{ mA}$ ⁽⁴⁾	1.02		1.40	V (Max)
t_S	Switching Time	$V_{CE} = 20V, R_L = 200\Omega$ $V_{BE} = 0V, +2V, 0V$	2			μs
θ_{JA}	Thermal Resistance Junction to Ambient	0.4" leads soldered to printed circuit board	150		180	$^{\circ}\text{C/W}$ (Max)
		0.125" leads soldered to printed circuit board	130		160	$^{\circ}\text{C/W}$ (Max)

- (1) Specified and 100% production tested.
- (2) Specified (but not 100% production tested) over the operating temperature and supply voltage ranges. These limits are not used to calculate outgoing quality levels.
- (3) Parameters identified with **boldface type** apply at temp. extremes. All other numbers, unless noted apply at +25°C.
- (4) These numbers apply for pulse testing with a low duty cycle.
- (5) Base positive with respect to emitter.

SIMPLIFIED CIRCUIT

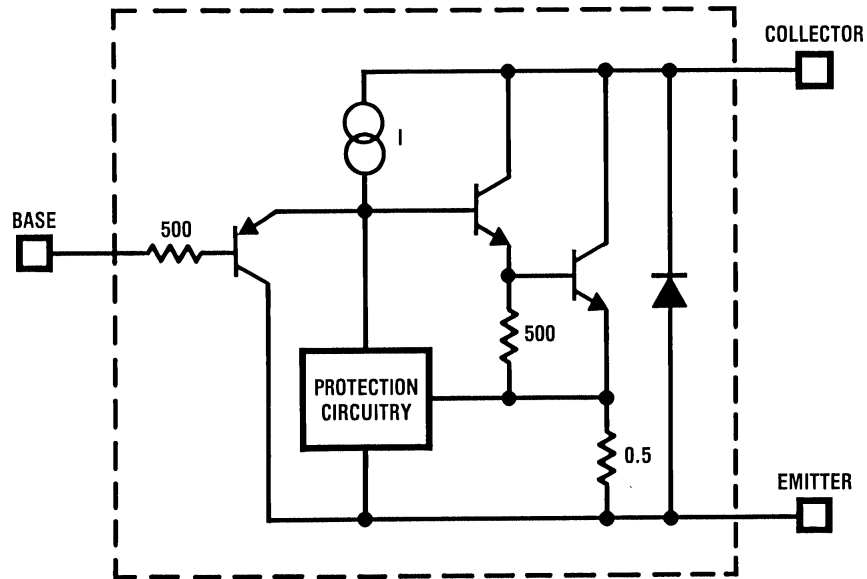

APPLICATIONS INFORMATION

One failure mode incandescent lamps may experience is one in which the filament resistance drops to a very low value before it actually blows out. This is especially rough on most solid-state lamp drivers and in most cases a lamp failure of this type will also cause the lamp driver to fail. Because of its high gain and blowout-proof design, the LP395 is an ideal candidate for reliably driving small incandescent lamps. Additionally, the current limiting characteristics of the LP395 are advantageous as it serves to limit the cold filament inrush current, thus increasing lamp life.

TYPICAL PERFORMANCE CHARACTERISTICS

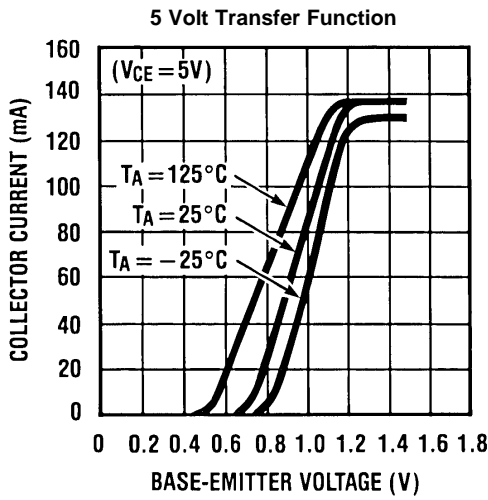

Figure 3.

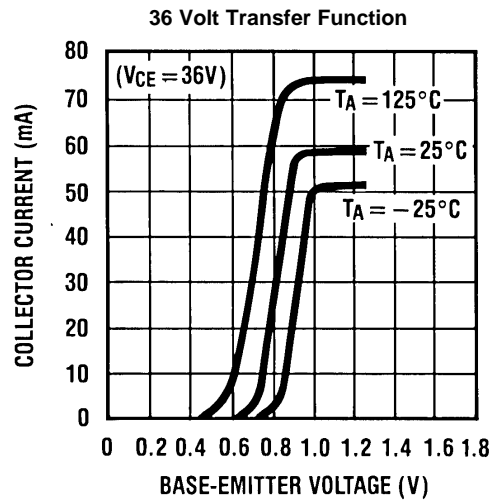

Figure 4.

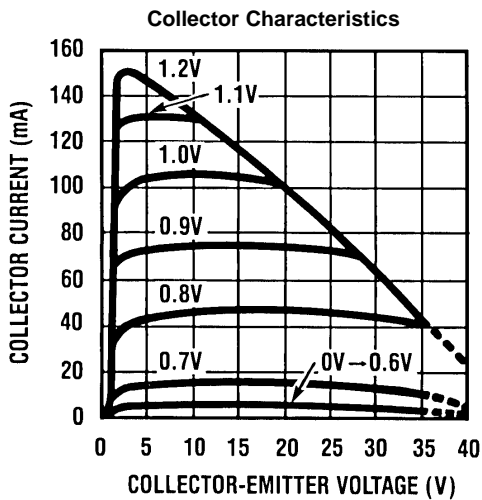

Figure 5.

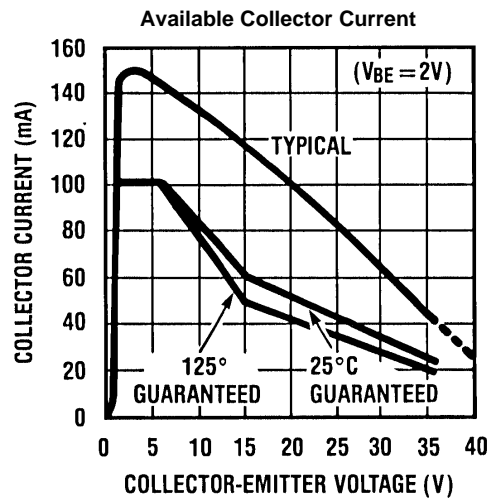

Figure 6.

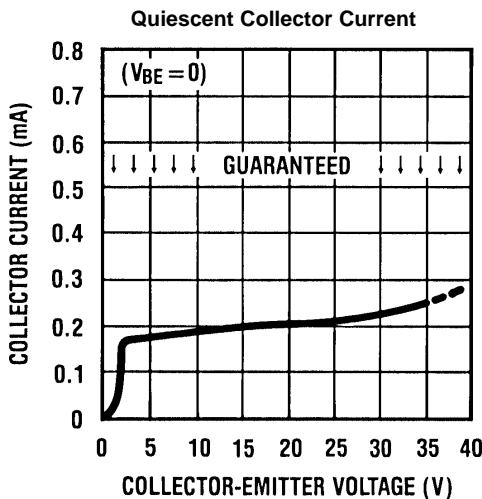

Figure 7.

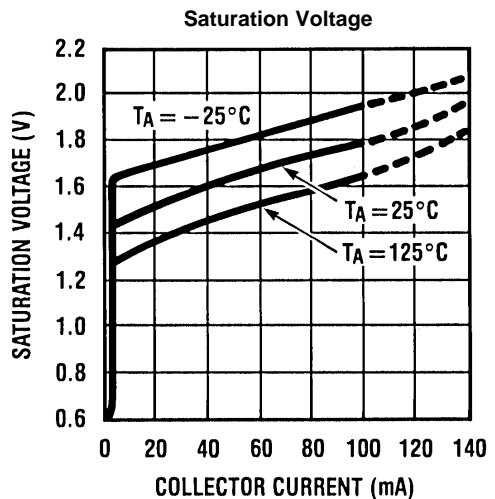

Figure 8.

TYPICAL PERFORMANCE CHARACTERISTICS (continued)

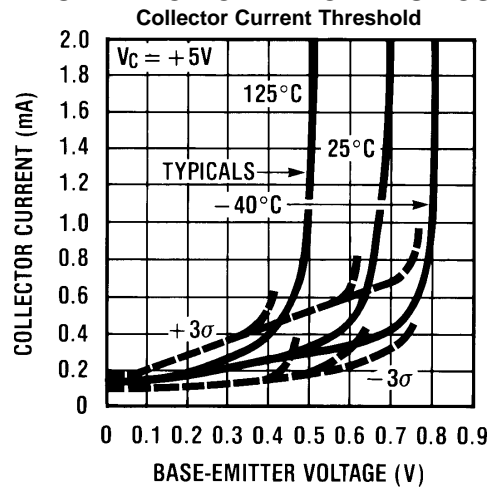

Figure 9.

TYPICAL APPLICATIONS

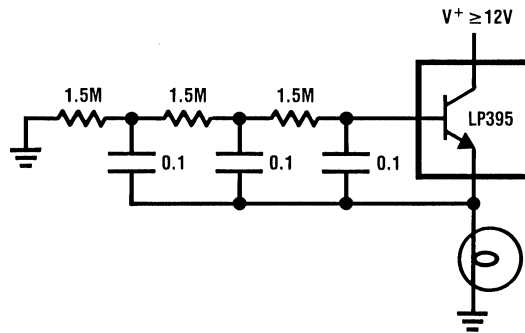

Figure 10. Lamp Flasher (Short Circuit Proof)

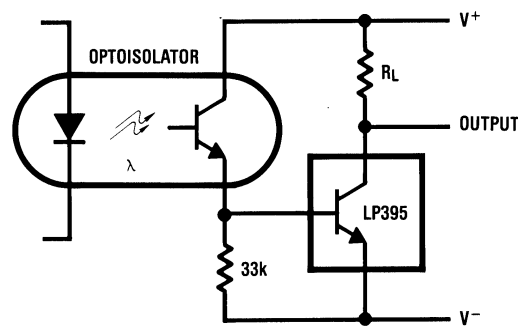

Figure 11. Optically Isolated Switch

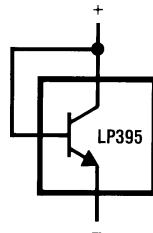

Figure 12. Two Terminal Current Limiter

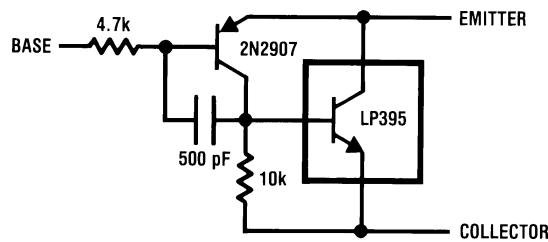

Figure 13. Composite PNP

REVISION HISTORY

Changes from Revision B (March 2013) to Revision C	Page
• Changed layout of National Data Sheet to TI format	6

PACKAGING INFORMATION

Orderable Device	Status (1)	Package Type	Package Drawing	Pins	Package Qty	Eco Plan (2)	Lead/Ball Finish (6)	MSL Peak Temp (3)	Op Temp (°C)	Device Marking (4/5)	Samples
LP395Z/LFT1	ACTIVE	TO-92	LP	3	2000	Green (RoHS & no Sb/Br)	CU SN	N / A for Pkg Type		LP 395Z	Samples
LP395Z/NOPB	ACTIVE	TO-92	LP	3	1800	Green (RoHS & no Sb/Br)	CU SN	N / A for Pkg Type	-40 to 125	LP 395Z	Samples

(1) The marketing status values are defined as follows:

ACTIVE: Product device recommended for new designs.

LIFEBUY: TI has announced that the device will be discontinued, and a lifetime-buy period is in effect.

NRND: Not recommended for new designs. Device is in production to support existing customers, but TI does not recommend using this part in a new design.

PREVIEW: Device has been announced but is not in production. Samples may or may not be available.

OBSOLETE: TI has discontinued the production of the device.

(2) **RoHS:** TI defines "RoHS" to mean semiconductor products that are compliant with the current EU RoHS requirements for all 10 RoHS substances, including the requirement that RoHS substance do not exceed 0.1% by weight in homogeneous materials. Where designed to be soldered at high temperatures, "RoHS" products are suitable for use in specified lead-free processes. TI may reference these types of products as "Pb-Free".

RoHS Exempt: TI defines "RoHS Exempt" to mean products that contain lead but are compliant with EU RoHS pursuant to a specific EU RoHS exemption.

Green: TI defines "Green" to mean the content of Chlorine (Cl) and Bromine (Br) based flame retardants meet JS709B low halogen requirements of <=1000ppm threshold. Antimony trioxide based flame retardants must also meet the <=1000ppm threshold requirement.

(3) MSL, Peak Temp. - The Moisture Sensitivity Level rating according to the JEDEC industry standard classifications, and peak solder temperature.

(4) There may be additional marking, which relates to the logo, the lot trace code information, or the environmental category on the device.

(5) Multiple Device Markings will be inside parentheses. Only one Device Marking contained in parentheses and separated by a "~" will appear on a device. If a line is indented then it is a continuation of the previous line and the two combined represent the entire Device Marking for that device.

(6) Lead/Ball Finish - Orderable Devices may have multiple material finish options. Finish options are separated by a vertical ruled line. Lead/Ball Finish values may wrap to two lines if the finish value exceeds the maximum column width.

Important Information and Disclaimer:The information provided on this page represents TI's knowledge and belief as of the date that it is provided. TI bases its knowledge and belief on information provided by third parties, and makes no representation or warranty as to the accuracy of such information. Efforts are underway to better integrate information from third parties. TI has taken and continues to take reasonable steps to provide representative and accurate information but may not have conducted destructive testing or chemical analysis on incoming materials and chemicals. TI and TI suppliers consider certain information to be proprietary, and thus CAS numbers and other limited information may not be available for release.

In no event shall TI's liability arising out of such information exceed the total purchase price of the TI part(s) at issue in this document sold by TI to Customer on an annual basis.

GENERIC PACKAGE VIEW

LP 3

TO-92 - 5.34 mm max height

TRANSISTOR OUTLINE

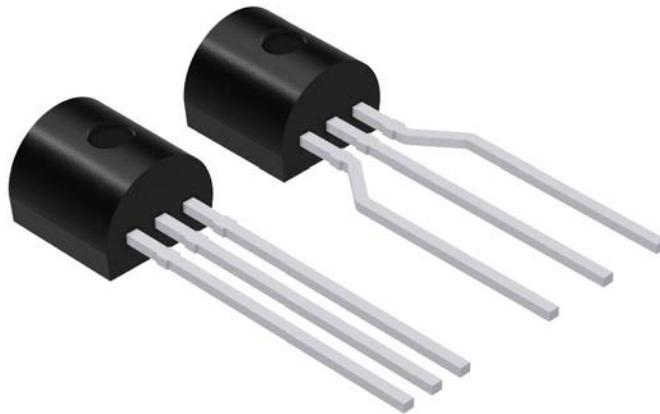

Images above are just a representation of the package family, actual package may vary.
Refer to the product data sheet for package details.

4040001-2/F

LP0003A



PACKAGE OUTLINE

TO-92 - 5.34 mm max height

TO-92

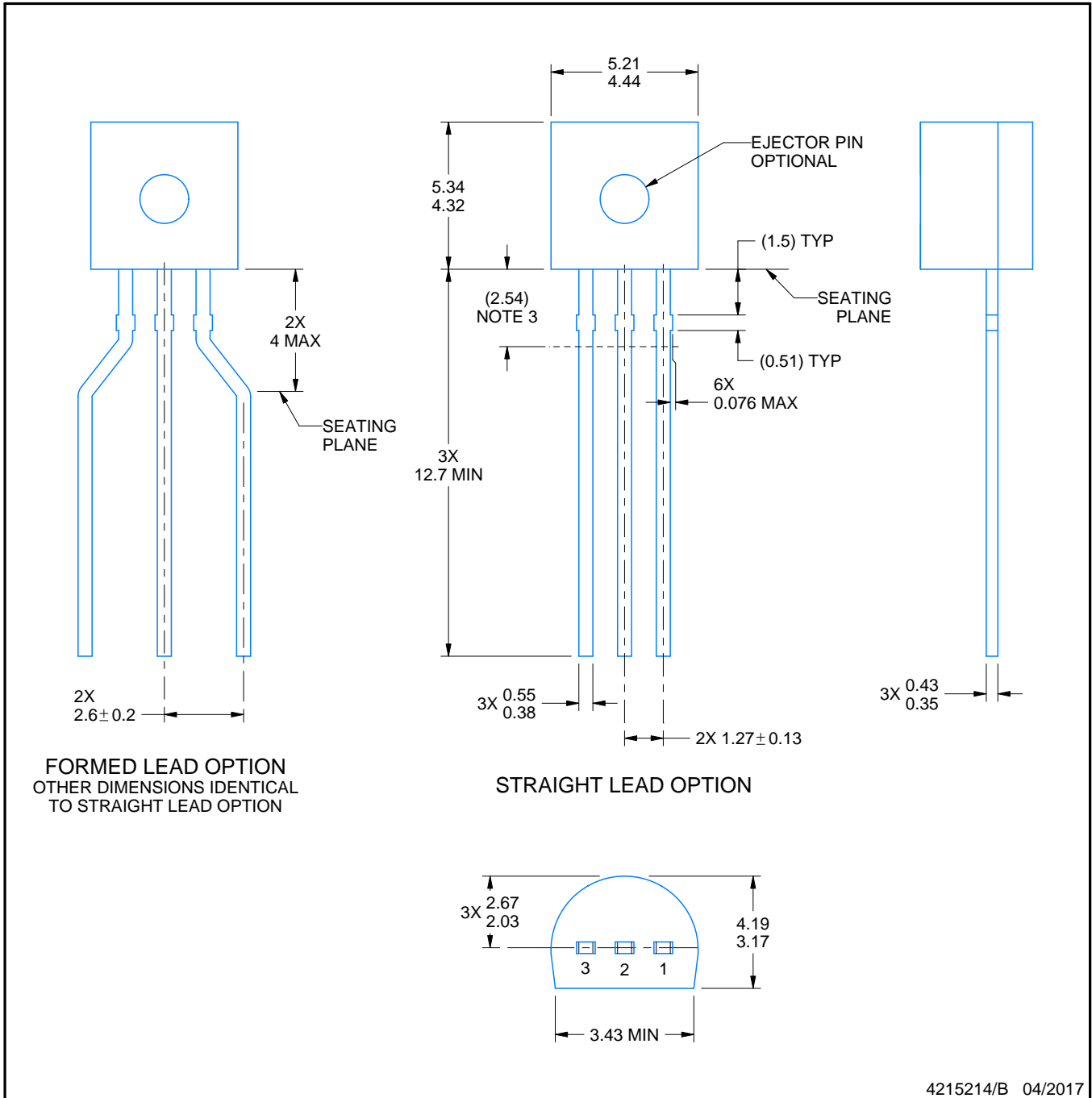

4215214/B 04/2017

NOTES:

1. All linear dimensions are in millimeters. Any dimensions in parenthesis are for reference only. Dimensioning and tolerancing per ASME Y14.5M.
2. This drawing is subject to change without notice.
3. Lead dimensions are not controlled within this area.
4. Reference JEDEC TO-226, variation AA.
5. Shipping method:
 - a. Straight lead option available in bulk pack only.
 - b. Formed lead option available in tape and reel or ammo pack.
 - c. Specific products can be offered in limited combinations of shipping medium and lead options.
 - d. Consult product folder for more information on available options.

EXAMPLE BOARD LAYOUT

LP0003A

TO-92 - 5.34 mm max height

TO-92

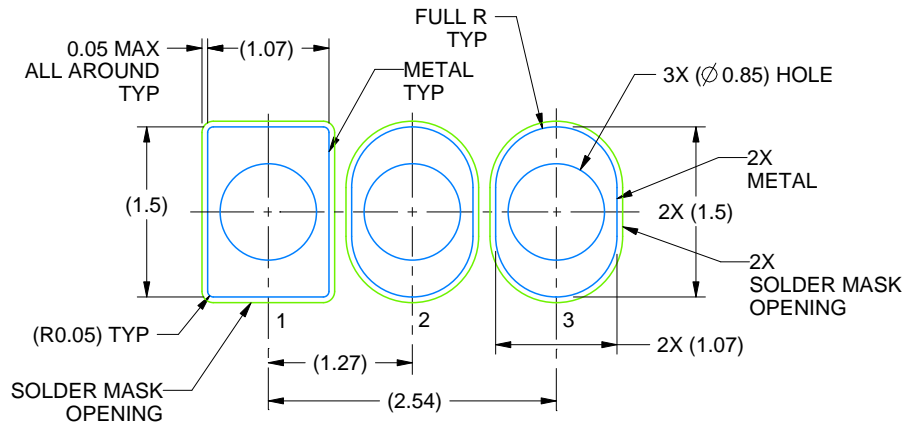

LAND PATTERN EXAMPLE
STRAIGHT LEAD OPTION
NON-SOLDER MASK DEFINED
SCALE:15X

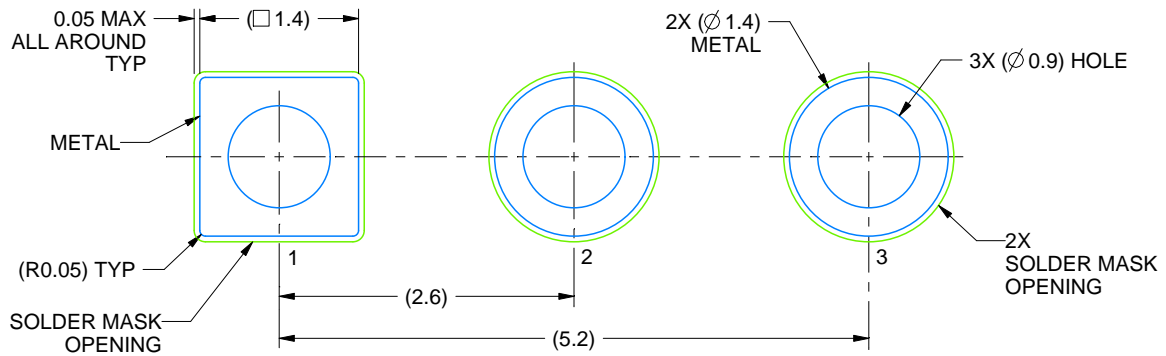

LAND PATTERN EXAMPLE
FORMED LEAD OPTION
NON-SOLDER MASK DEFINED
SCALE:15X

4215214/B 04/2017

TAPE SPECIFICATIONS

LP0003A

TO-92 - 5.34 mm max height

TO-92

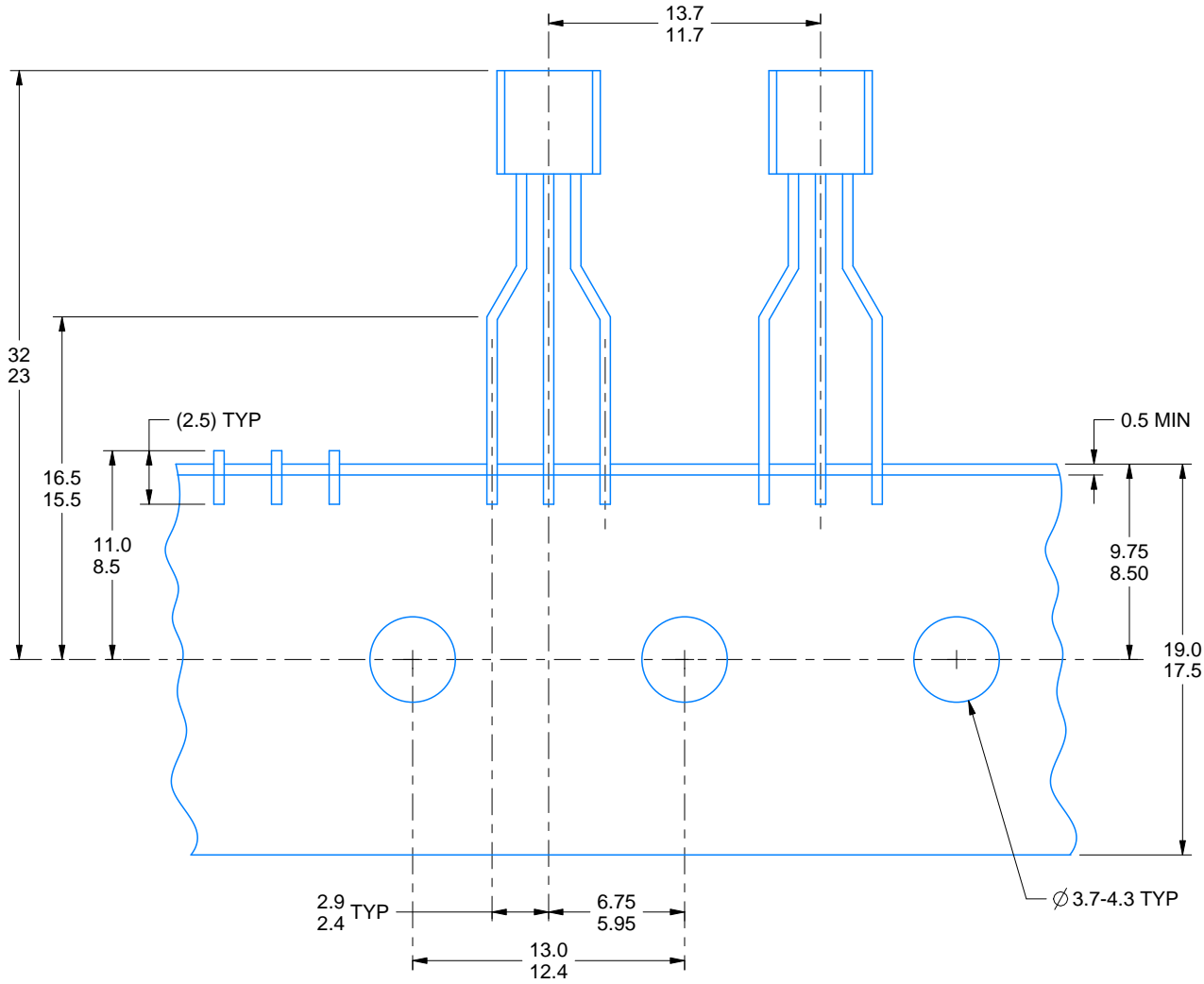

FOR FORMED LEAD OPTION PACKAGE

4215214/B 04/2017

IMPORTANT NOTICE

Texas Instruments Incorporated (TI) reserves the right to make corrections, enhancements, improvements and other changes to its semiconductor products and services per JESD46, latest issue, and to discontinue any product or service per JESD48, latest issue. Buyers should obtain the latest relevant information before placing orders and should verify that such information is current and complete.

TI's published terms of sale for semiconductor products (<http://www.ti.com/sc/docs/stdterms.htm>) apply to the sale of packaged integrated circuit products that TI has qualified and released to market. Additional terms may apply to the use or sale of other types of TI products and services.

Reproduction of significant portions of TI information in TI data sheets is permissible only if reproduction is without alteration and is accompanied by all associated warranties, conditions, limitations, and notices. TI is not responsible or liable for such reproduced documentation. Information of third parties may be subject to additional restrictions. Resale of TI products or services with statements different from or beyond the parameters stated by TI for that product or service voids all express and any implied warranties for the associated TI product or service and is an unfair and deceptive business practice. TI is not responsible or liable for any such statements.

Buyers and others who are developing systems that incorporate TI products (collectively, "Designers") understand and agree that Designers remain responsible for using their independent analysis, evaluation and judgment in designing their applications and that Designers have full and exclusive responsibility to assure the safety of Designers' applications and compliance of their applications (and of all TI products used in or for Designers' applications) with all applicable regulations, laws and other applicable requirements. Designer represents that, with respect to their applications, Designer has all the necessary expertise to create and implement safeguards that (1) anticipate dangerous consequences of failures, (2) monitor failures and their consequences, and (3) lessen the likelihood of failures that might cause harm and take appropriate actions. Designer agrees that prior to using or distributing any applications that include TI products, Designer will thoroughly test such applications and the functionality of such TI products as used in such applications.

TI's provision of technical, application or other design advice, quality characterization, reliability data or other services or information, including, but not limited to, reference designs and materials relating to evaluation modules, (collectively, "TI Resources") are intended to assist designers who are developing applications that incorporate TI products; by downloading, accessing or using TI Resources in any way, Designer (individually or, if Designer is acting on behalf of a company, Designer's company) agrees to use any particular TI Resource solely for this purpose and subject to the terms of this Notice.

TI's provision of TI Resources does not expand or otherwise alter TI's applicable published warranties or warranty disclaimers for TI products, and no additional obligations or liabilities arise from TI providing such TI Resources. TI reserves the right to make corrections, enhancements, improvements and other changes to its TI Resources. TI has not conducted any testing other than that specifically described in the published documentation for a particular TI Resource.

Designer is authorized to use, copy and modify any individual TI Resource only in connection with the development of applications that include the TI product(s) identified in such TI Resource. NO OTHER LICENSE, EXPRESS OR IMPLIED, BY ESTOPPEL OR OTHERWISE TO ANY OTHER TI INTELLECTUAL PROPERTY RIGHT, AND NO LICENSE TO ANY TECHNOLOGY OR INTELLECTUAL PROPERTY RIGHT OF TI OR ANY THIRD PARTY IS GRANTED HEREIN, including but not limited to any patent right, copyright, mask work right, or other intellectual property right relating to any combination, machine, or process in which TI products or services are used. Information regarding or referencing third-party products or services does not constitute a license to use such products or services, or a warranty or endorsement thereof. Use of TI Resources may require a license from a third party under the patents or other intellectual property of the third party, or a license from TI under the patents or other intellectual property of TI.

TI RESOURCES ARE PROVIDED "AS IS" AND WITH ALL FAULTS. TI DISCLAIMS ALL OTHER WARRANTIES OR REPRESENTATIONS, EXPRESS OR IMPLIED, REGARDING RESOURCES OR USE THEREOF, INCLUDING BUT NOT LIMITED TO ACCURACY OR COMPLETENESS, TITLE, ANY EPIDEMIC FAILURE WARRANTY AND ANY IMPLIED WARRANTIES OF MERCHANTABILITY, FITNESS FOR A PARTICULAR PURPOSE, AND NON-INFRINGEMENT OF ANY THIRD PARTY INTELLECTUAL PROPERTY RIGHTS. TI SHALL NOT BE LIABLE FOR AND SHALL NOT DEFEND OR INDEMNIFY DESIGNER AGAINST ANY CLAIM, INCLUDING BUT NOT LIMITED TO ANY INFRINGEMENT CLAIM THAT RELATES TO OR IS BASED ON ANY COMBINATION OF PRODUCTS EVEN IF DESCRIBED IN TI RESOURCES OR OTHERWISE. IN NO EVENT SHALL TI BE LIABLE FOR ANY ACTUAL, DIRECT, SPECIAL, COLLATERAL, INDIRECT, PUNITIVE, INCIDENTAL, CONSEQUENTIAL OR EXEMPLARY DAMAGES IN CONNECTION WITH OR ARISING OUT OF TI RESOURCES OR USE THEREOF, AND REGARDLESS OF WHETHER TI HAS BEEN ADVISED OF THE POSSIBILITY OF SUCH DAMAGES.

Unless TI has explicitly designated an individual product as meeting the requirements of a particular industry standard (e.g., ISO/TS 16949 and ISO 26262), TI is not responsible for any failure to meet such industry standard requirements.



Where TI specifically promotes products as facilitating functional safety or as compliant with industry functional safety standards, such products are intended to help enable customers to design and create their own applications that meet applicable functional safety standards and requirements. Using products in an application does not by itself establish any safety features in the application. Designers must ensure compliance with safety-related requirements and standards applicable to their applications. Designer may not use any TI products in life-critical medical equipment unless authorized officers of the parties have executed a special contract specifically governing such use. Life-critical medical equipment is medical equipment where failure of such equipment would cause serious bodily injury or death (e.g., life support, pacemakers, defibrillators, heart pumps, neurostimulators, and implantables). Such equipment includes, without limitation, all medical devices identified by the U.S. Food and Drug Administration as Class III devices and equivalent classifications outside the U.S.

TI may expressly designate certain products as completing a particular qualification (e.g., Q100, Military Grade, or Enhanced Product). Designers agree that it has the necessary expertise to select the product with the appropriate qualification designation for their applications and that proper product selection is at Designers' own risk. Designers are solely responsible for compliance with all legal and regulatory requirements in connection with such selection.

Designer will fully indemnify TI and its representatives against any damages, costs, losses, and/or liabilities arising out of Designer's non-compliance with the terms and provisions of this Notice.

Looking for pricing, stock, or lifecycle information?

Click below to explore more details on WIN SOURCE:

-  [View LP395Z/NOPB on WIN SOURCE](#)
-  [Texas Instruments](#) Information

Optimize Your Supply Chain with WIN SOURCE Solutions

-  Global Sourcing Solution
-  Obsolete Management
-  Cost Control Management
-  Shortage Management
-  Alternative Solution
-  Excess Inventory Management