



**THE DATASHEET OF  
AT29LV1024-15TC**



## Features

- Single Voltage Range, 3V to 3.6V Supply
- 3-volt Only Read and Write Operation
- Software Protected Programming
- Fast Read Access Time - 150 ns
- Low Power Dissipation
  - 15 mA Active Current
  - 50  $\mu$ A CMOS Standby Current
- Sector Program Operation
  - Single-cycle Reprogram (Erase and Program)
  - 512 Sectors (128 words/sector)
  - Internal Address and Data Latches for 128 Words
- Fast Sector Program Cycle Time - 20 ms
- Internal Program Control and Timer
- $\overline{\text{DATA}}$  Polling for End of Program Detection
- Typical Endurance > 10,000 Cycles
- CMOS and TTL Compatible Inputs and Outputs
- Commercial and Industrial Temperature Ranges

## Description

The AT29LV1024 is a 3-volt only in-system Flash programmable and erasable read only memory (PEROM). Its 1 megabit of memory is organized as 65,536 words by 16 bits. Manufactured with Atmel's advanced nonvolatile CMOS technology, the device offers access times to 150 ns with power dissipation of just 54 mW. When the device is deselected, the CMOS standby current is less than 50  $\mu$ A. The device endurance is

*(continued)*

## Pin Configurations

Pin Name	Function
A0 - A15	Addresses
$\overline{\text{CE}}$	Chip Enable
$\overline{\text{OE}}$	Output Enable
$\overline{\text{WE}}$	Write Enable
I/O0 - I/O15	Data Inputs/Outputs
NC	No Connect
DC	Don't Connect

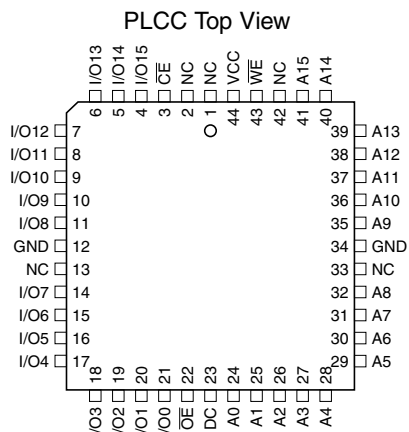

TSOP Top View  
Type 1

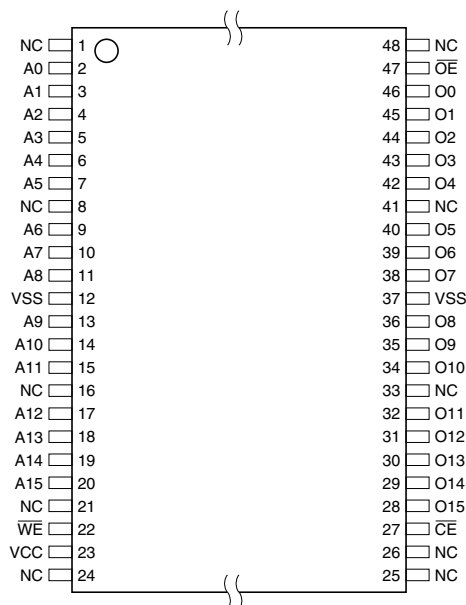

**1-megabit  
(64K x 16)  
3-volt Only  
Flash Memory**

**AT29LV1024**



such that any sector can typically be written to in excess of 10,000 times.

To allow for simple in-system reprogrammability, the AT29LV1024 does not require high input voltages for programming. Three-volt-only commands determine the operation of the device. Reading data out of the device is similar to reading from an EPROM. Reprogramming the AT29LV1024 is performed on a sector basis; 128 words of data are loaded into the device and then simultaneously programmed.

During a reprogram cycle, the address locations and 128 words of data are internally latched, freeing the address and data bus for other operations. Following the initiation of a program cycle, the device will automatically erase the sector and then program the latched data using an internal control timer. The end of a program cycle can be detected by  $\overline{\text{DATA}}$  polling of I/O7 or I/O15. Once the end of a program cycle has been detected, a new access for a read or program can begin.

## Block Diagram

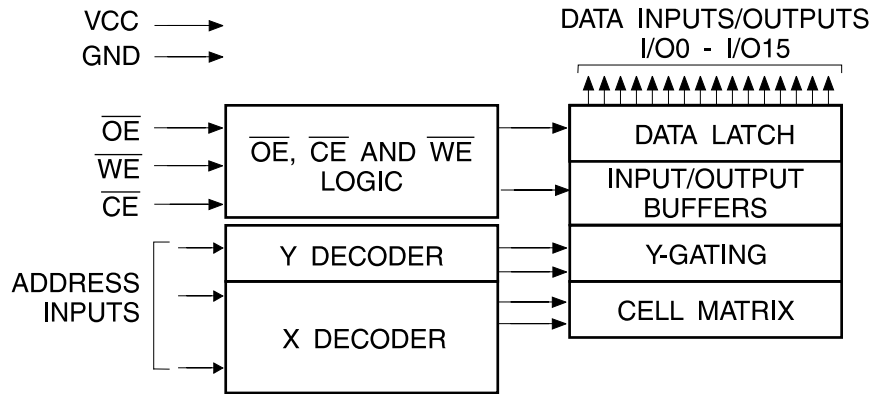

## Device Operation

**READ:** The AT29LV1024 is accessed like an EPROM. When  $\overline{\text{CE}}$  and  $\overline{\text{OE}}$  are low and  $\overline{\text{WE}}$  is high, the data stored at the memory location determined by the address pins is asserted on the outputs. The outputs are put in the high impedance state whenever  $\overline{\text{CE}}$  or  $\overline{\text{OE}}$  is high. This dual-line control gives designers flexibility in preventing bus contention.

**SOFTWARE DATA PROTECTION PROGRAMMING:** The AT29LV1024 has 512 individual sectors, each 128 words. Using the software data protection feature, word loads are used to enter the 128 words of a sector to be programmed. The AT29LV1024 can only be programmed or reprogrammed using the software data protection feature. The device is programmed on a sector basis. If a word of data within the sector is to be changed, data for the entire 128 word sector must be loaded into the device. The AT29LV1024 automatically does a sector erase prior to loading the data into the sector. An erase command is not required.

Software data protection protects the device from inadvertent programming. A series of three program commands to specific addresses with specific data must be presented to the device before programming may occur. The same three program commands must begin each program operation. All software program commands must obey the sector program timing specifications. Power transitions will not reset the software data protection feature, however the software

feature will guard against inadvertent program cycles during power transitions.

Any attempt to write to the device without the 3-word command sequence will start the internal write timers. No data will be written to the device; however, for the duration of  $t_{\text{WC}}$ , a read operation will effectively be a polling operation.

After the software data protection's 3-word command code is given, a word load is performed by applying a low pulse on the  $\overline{\text{WE}}$  or  $\overline{\text{CE}}$  input with  $\overline{\text{CE}}$  or  $\overline{\text{WE}}$  low (respectively) and  $\overline{\text{OE}}$  high. The address is latched on the falling edge of  $\overline{\text{CE}}$  or  $\overline{\text{WE}}$ , whichever occurs last. The data is latched by the first rising edge of  $\overline{\text{CE}}$  or  $\overline{\text{WE}}$ .

The 128 words of data must be loaded into each sector. Any word that is not loaded during the programming of its sector will be erased to read FFFFH. Once the words of a sector are loaded into the device, they are simultaneously programmed during the internal programming period. After the first data word has been loaded into the device, successive words are entered in the same manner. Each new word to be programmed must have its high to low transition on  $\overline{\text{WE}}$  (or  $\overline{\text{CE}}$ ) within 150  $\mu\text{s}$  of the low to high transition of  $\overline{\text{WE}}$  (or  $\overline{\text{CE}}$ ) of the preceding word. If a high to low transition is not detected within 150  $\mu\text{s}$  of the last low to high transition, the load period will end and the internal programming period will start. A7 to A15 specify the sector address. The sector address must be valid during each high to low transi-

tion of  $\overline{WE}$  (or  $\overline{CE}$ ). A0 to A6 specify the word address within the sector. The words may be loaded in any order; sequential loading is not required. Once a programming operation has been initiated, and for the duration of  $t_{WC}$ , a read operation will effectively be a polling operation.

**HARDWARE DATA PROTECTION:** Hardware features protect against inadvertent programs to the AT29LV1024 in the following ways: (a)  $V_{CC}$  sense—if  $V_{CC}$  is below 1.8V (typical), the program function is inhibited; (b)  $V_{CC}$  power on delay—once  $V_{CC}$  has reached the  $V_{CC}$  sense level, the device will automatically time out 10 ms (typical) before programming; (c) Program inhibit—holding any one of  $\overline{OE}$  low,  $\overline{CE}$  high or  $\overline{WE}$  high inhibits program cycles; and (d) Noise filter—pulses of less than 15 ns (typical) on the  $\overline{WE}$  or  $\overline{CE}$  inputs will not initiate a program cycle.

**INPUT LEVELS:** While operating with a 3.3V  $\pm 10\%$  power supply, the address inputs and control inputs ( $\overline{OE}$ ,  $\overline{CE}$  and  $\overline{WE}$ ) may be driven from 0 to 5.5V without adversely affecting the operation of the device. The I/O lines can be driven from 0 to 3.6V.

**PRODUCT IDENTIFICATION:** The product identification mode identifies the device and manufacturer as Atmel. It may be accessed by hardware or software operation. The hardware operation mode can be used by an external programmer to identify the correct programming algorithm for the Atmel product. In addition, users may wish to use the software product identification mode to identify the part (i.e. using the device code), and have the system software use the appropriate sector size for program operations. In this

manner, the user can have a common board design for various Flash densities and, with each density's sector size in a memory map, have the system software apply the appropriate sector size.

For details, see Operating Modes (for hardware operation) or Software Product Identification. The manufacturer and device code is the same for both modes.

**DATA POLLING:** The AT29LV1024 features  $\overline{DATA}$  polling to indicate the end of a program cycle. During a program cycle an attempted read of the last word loaded will result in the complement of the loaded data on I/O7 and I/O15. Once the program cycle has been completed, true data is valid on all outputs and the next cycle may begin.  $\overline{DATA}$  polling may begin at any time during the program cycle.

**TOGGLE BIT:** In addition to  $\overline{DATA}$  polling the AT29LV1024 provides another method for determining the end of a program or erase cycle. During a program or erase operation, successive attempts to read data from the device will result in I/O6 and I/O14 toggling between one and zero. Once the program cycle has completed, I/O6 and I/O14 will stop toggling and valid data will be read. Examining the toggle bit may begin at any time during a program cycle.

**OPTIONAL CHIP ERASE MODE:** The entire device can be erased by using a 6-byte software code. Please see Software Chip Erase application note for details.

## Absolute Maximum Ratings\*

Temperature Under Bias.....	-55°C to +125°C
Storage Temperature .....	-65°C to +150°C
All Input Voltages (including NC Pins) with Respect to Ground .....	-0.6V to +6.25V
All Output Voltages with Respect to Ground .....	-0.6V to $V_{CC} + 0.6V$
Voltage on A9 (including NC Pins) with Respect to Ground .....	-0.6V to +13.5V

\*NOTICE: Stresses beyond those listed under “Absolute Maximum Ratings” may cause permanent damage to the device. This is a stress rating only and functional operation of the device at these or any other conditions beyond those indicated in the operational sections of this specification is not implied. Exposure to absolute maximum rating conditions for extended periods may affect device reliability



## DC and AC Operating Range

		AT29LV1024-15	AT29LV1024-20	AT29LV1024-25
Operating Temperature (Case)	Com.	0°C - 70°C	0°C - 70°C	0°C - 70°C
	Ind.	-40°C - 85°C	-40°C - 85°C	-40°C - 85°C
V <sub>CC</sub> Power Supply <sup>(1)</sup>		3.3V ± 0.3V	3.3V ± 0.3V	3.3V ± 0.3V

Note: 1. After power is applied and V<sub>CC</sub> is at the minimum specified data sheet value, the system should wait 20 ms before an operational mode is started.

## Operating Modes

Mode	$\overline{CE}$	$\overline{OE}$	$\overline{WE}$	Ai	I/O
Read	V <sub>IL</sub>	V <sub>IL</sub>	V <sub>IH</sub>	Ai	D <sub>OUT</sub>
Program <sup>(2)</sup>	V <sub>IL</sub>	V <sub>IH</sub>	V <sub>IL</sub>	Ai	D <sub>IN</sub>
Standby/Write Inhibit	V <sub>IH</sub>	X <sup>(1)</sup>	X	X	High Z
Program Inhibit	X	X	V <sub>IH</sub>		
Program Inhibit	X	V <sub>IL</sub>	X		
Output Disable	X	V <sub>IH</sub>	X		High Z
Product Identification					
Hardware	V <sub>IL</sub>	V <sub>IL</sub>	V <sub>IH</sub>	A1 - A15 = V <sub>IL</sub> , A9 = V <sub>H</sub> , <sup>(3)</sup> A0 = V <sub>IL</sub>	Manufacturer Code <sup>(4)</sup>
				A1 - A15 = V <sub>IL</sub> , A9 = V <sub>H</sub> , <sup>(3)</sup> A0 = V <sub>IH</sub>	Device Code <sup>(4)</sup>
Software <sup>(5)</sup>				A0 = V <sub>IL</sub>	Manufacturer Code <sup>(4)</sup>
				A0 = V <sub>IH</sub>	Device Code <sup>(4)</sup>

- Notes:
1. X can be V<sub>IL</sub> or V<sub>IH</sub>.
  2. Refer to AC Programming Waveforms.
  3. V<sub>H</sub> = 12.0V ± 0.5V.
  4. Manufacturer Code: 1F, Device Code: 26.
  5. See details under Software Product Identification Entry/Exit.

## DC Characteristics

Symbol	Parameter	Condition	Min	Max	Units
I <sub>LI</sub>	Input Load Current	V <sub>IN</sub> = 0V to V <sub>CC</sub>		1	μA
I <sub>LO</sub>	Output Leakage Current	V <sub>I/O</sub> = 0V to V <sub>CC</sub>		1	μA
I <sub>SB1</sub>	V <sub>CC</sub> Standby Current CMOS	$\overline{CE} = V_{CC} - 0.3V$ to V <sub>CC</sub>	Com.	50	μA
			Ind.	100	μA
I <sub>SB2</sub>	V <sub>CC</sub> Standby Current TTL	$\overline{CE} = 2.0V$ to V <sub>CC</sub>		1	mA
I <sub>CC</sub>	V <sub>CC</sub> Active Current	f = 5 MHz; I <sub>OUT</sub> = 0 mA, V <sub>CC</sub> = 3.6V		15	mA
V <sub>IL</sub>	Input Low Voltage			0.6	V
V <sub>IH</sub>	Input High Voltage		2.0		V
V <sub>OL</sub>	Output Low Voltage	I <sub>OL</sub> = 1.6 mA, V <sub>CC</sub> = 3.0V		0.45	V
V <sub>OH1</sub>	Output High Voltage	I <sub>OH</sub> = 100 μA, V <sub>CC</sub> = 3.0V	2.4		V

## AC Read Characteristics

Symbol	Parameter	AT29LV1024-15		AT29LV1024-20		AT29LV1024-25		Units
		Min	Max	Min	Max	Min	Max	
$t_{ACC}$	Address to Output Delay		150		200		250	ns
$t_{CE}^{(1)}$	$\overline{CE}$ to Output Delay		150		200		250	ns
$t_{OE}^{(2)}$	$\overline{OE}$ to Output Delay	0	85	0	100	0	120	ns
$t_{DF}^{(3)(4)}$	$\overline{CE}$ or $\overline{OE}$ to Output Float	0	40	0	50	0	60	ns
$t_{OH}$	Output Hold from $\overline{OE}$ , $\overline{CE}$ or Address, whichever occurred first	0		0		0		ns

## AC Read Waveforms<sup>(1)(2)(3)(4)</sup>

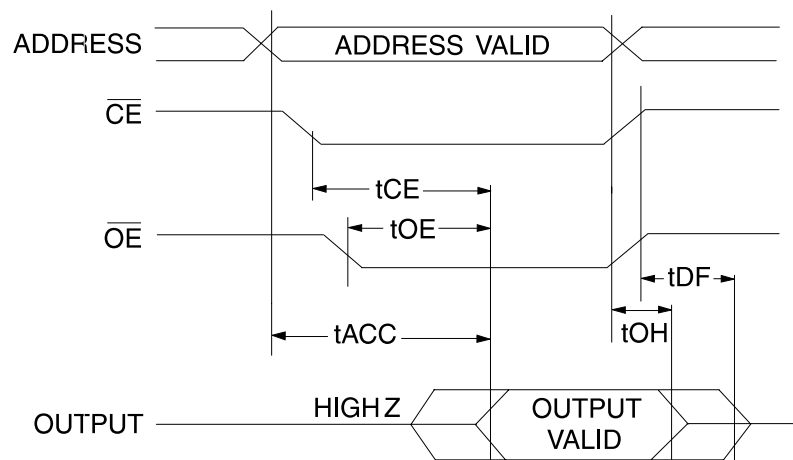

- Notes:
- $\overline{CE}$  may be delayed up to  $t_{ACC} - t_{CE}$  after the address transition without impact on  $t_{ACC}$ .
  - $\overline{OE}$  may be delayed up to  $t_{CE} - t_{OE}$  after the falling edge of  $\overline{CE}$  without impact on  $t_{CE}$  or by  $t_{ACC} - t_{OE}$  after an address change without impact on  $t_{ACC}$ .
  - $t_{DF}$  is specified from  $\overline{OE}$  or  $\overline{CE}$  whichever occurs first (CL = 5 pF).
  - This parameter is characterized and is not 100% tested.

## Input Test Waveforms and Measurement Level

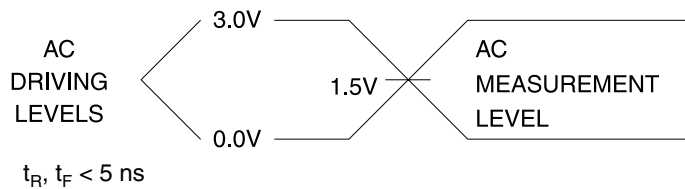

## Output Test Load

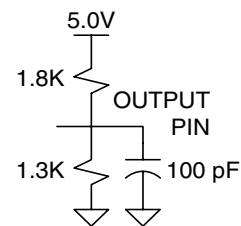

## Pin Capacitance

$f = 1 \text{ MHz}$ ,  $T = 25^\circ\text{C}^{(1)}$

Symbol	Typ	Max	Units	Conditions
$C_{IN}$	4	6	pF	$V_{IN} = 0V$
$C_{OUT}$	8	12	pF	$V_{OUT} = 0V$

- Note: 1. This parameter is characterized and is not 100% tested.

## AC Word Load Characteristics

Symbol	Parameter	Min	Max	Units
$t_{AS}, t_{OES}$	Address, $\overline{OE}$ Set-up Time	0		ns
$t_{AH}$	Address Hold Time	100		ns
$t_{CS}$	Chip Select Set-up Time	0		ns
$t_{CH}$	Chip Select Hold Time	0		ns
$t_{WP}$	Write Pulse Width ( $\overline{WE}$ or $\overline{CE}$ )	200		ns
$t_{DS}$	Data Set-up Time	100		ns
$t_{DH}, t_{OEH}$	Data, $\overline{OE}$ Hold Time	0		ns
$t_{WPH}$	Write Pulse Width High	200		ns

## AC Byte Load Waveforms<sup>(1)(2)</sup>

### $\overline{WE}$ Controlled

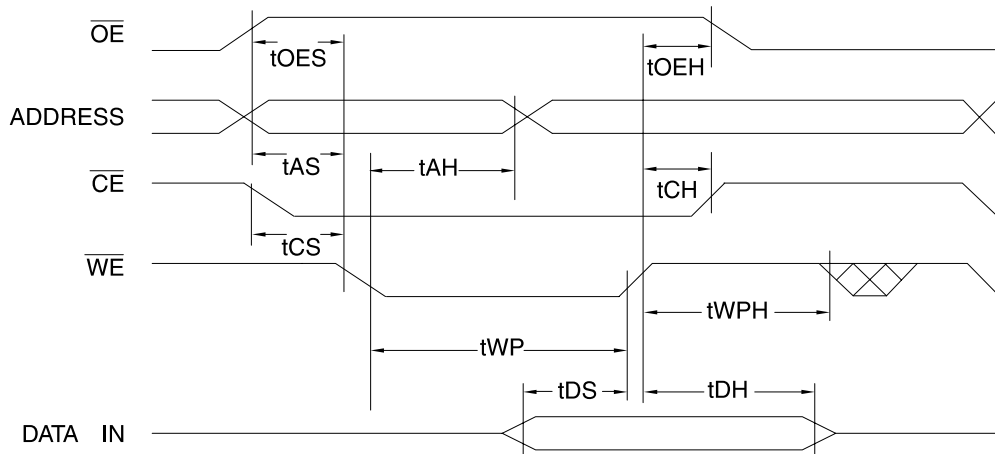

### $\overline{CE}$ Controlled

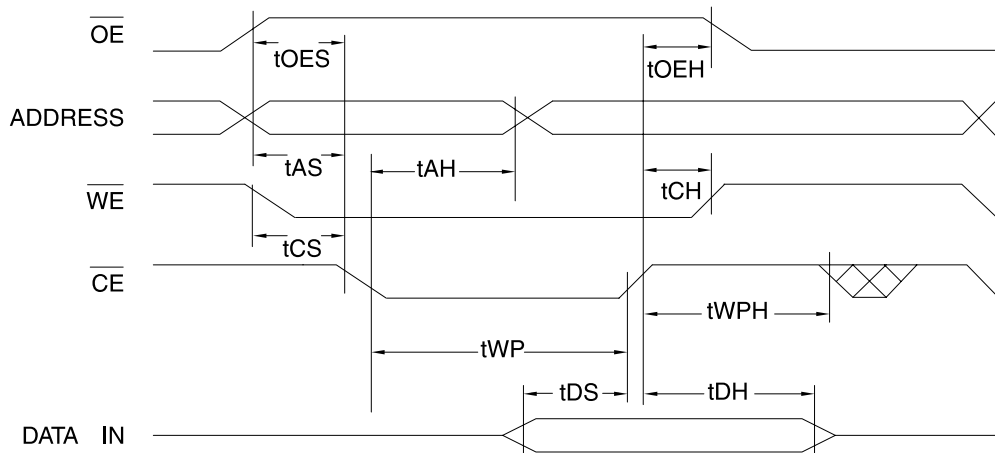

- Notes:
1. The software data protection commands must be applied prior to word loads.
  2. A complete sector (128 words) should be loaded using these waveforms as shown in the Software Protected Word Load waveforms (see next page).

### Program Cycle Characteristics

Symbol	Parameter	Min	Max	Units
$t_{WC}$	Write Cycle Time		20	ms
$t_{AS}$	Address Set-up Time	0		ns
$t_{AH}$	Address Hold Time	100		ns
$t_{DS}$	Data Set-up Time	100		ns
$t_{DH}$	Data Hold Time	0		ns
$t_{WP}$	Write Pulse Width	200		ns
$t_{WLC}$	Word Load Cycle Time		150	$\mu$ s
$t_{WPH}$	Write Pulse Width High	200		ns

### Software Protected Program Waveform<sup>(1)(2)(3)</sup>

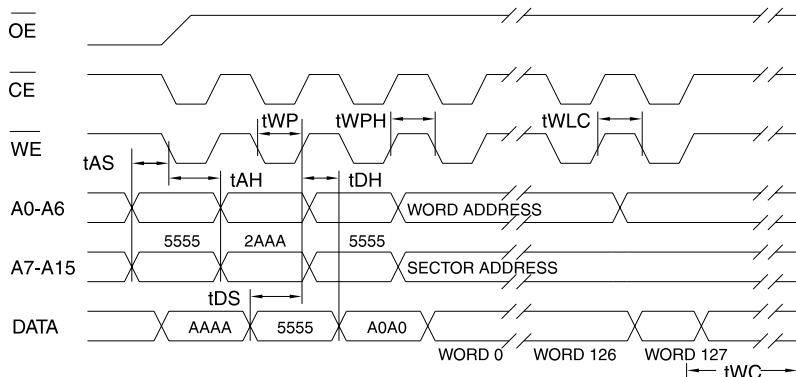

- Notes:
1. A7 through A15 must specify the sector address during each high to low transition of  $\overline{WE}$  (or  $\overline{CE}$ ) after the software code has been entered.
  2.  $\overline{OE}$  must be high when  $\overline{WE}$  and  $\overline{CE}$  are both low.
  3. All words that are not loaded within the sector being programmed will be indeterminate.

### Programming Algorithm<sup>(1)</sup>

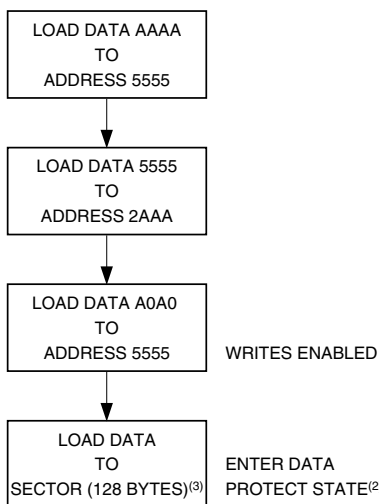

Notes for software program code:

1. Data Format: I/O7 - I/O0 (Hex); Address Format: A14 - A0 (Hex).
2. Data Protect state will be re-activated at end of program cycle.
3. 128 words of data **MUST BE** loaded.

## Data Polling Characteristics<sup>(1)</sup>

Symbol	Parameter	Min	Typ	Max	Units
$t_{DH}$	Data Hold Time	0			ns
$t_{OE\bar{H}}$	$\bar{O}\bar{E}$ Hold Time	0			ns
$t_{OE}$	$\bar{O}\bar{E}$ to Output Delay <sup>(2)</sup>				ns
$t_{WR}$	Write Recovery Time	0			ns

Notes: 1. These parameters are characterized and not 100% tested.  
2. See  $t_{OE}$  spec in AC Read Characteristics.

## Data Polling Waveforms

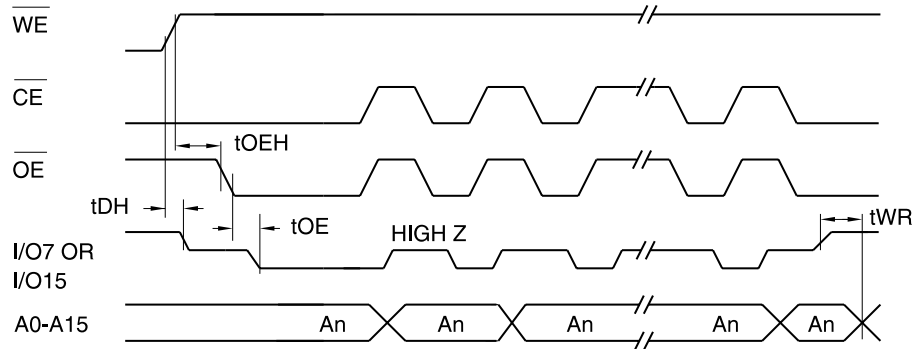

## Toggle Bit Characteristics<sup>(1)</sup>

Symbol	Parameter	Min	Typ	Max	Units
$t_{DH}$	Data Hold Time	10			ns
$t_{OE\bar{H}}$	$\bar{O}\bar{E}$ Hold Time	10			ns
$t_{OE}$	$\bar{O}\bar{E}$ to Output Delay <sup>(2)</sup>				ns
$t_{OEHP}$	$\bar{O}\bar{E}$ High Pulse	150			ns
$t_{WR}$	Write Recovery Time	0			ns

Notes: 1. These parameters are characterized and not 100% tested.  
2. See  $t_{OE}$  spec in AC Read Characteristics.

## Toggle Bit Waveforms<sup>(1)(2)(3)</sup>

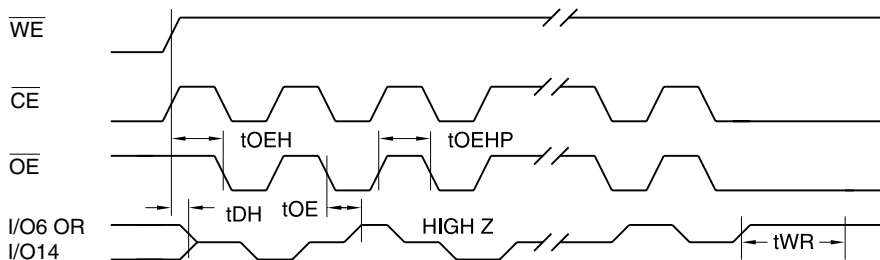

Notes: 1. Toggling either  $\bar{O}\bar{E}$  or  $\bar{C}\bar{E}$  or both  $\bar{O}\bar{E}$  and  $\bar{C}\bar{E}$  will operate toggle bit.  
2. Beginning and ending state of I/O6 and I/O14 may vary.  
3. Any address location may be used but the address should not vary.

## Software Product Identification Entry<sup>(1)</sup>

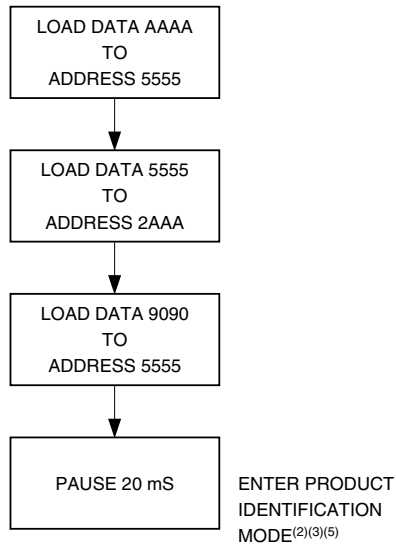

## Software Product Identification Exit<sup>(1)</sup>

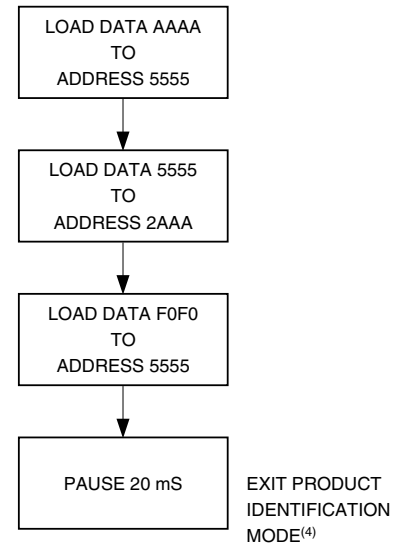

### Notes for software product identification:

1. Data Format: I/O15 - I/O0 (Hex);  
Address Format: A14 - A0 (Hex).
2. A1 - A15 =  $V_{IL}$ .  
Manufacturer Code is read for A0 =  $V_{IL}$ ;  
Device Code is read for A0 =  $V_{IH}$ .
3. The device does not remain in identification mode if powered down.
4. The device returns to standard operation mode.
5. Manufacturer Code is 1F. The Device Code is 26.



## Ordering Information

$t_{ACC}$ (ns)	$I_{CC}$ (mA)		Ordering Code	Package	Operation Range
	Active	Standby			
150	15	0.05	AT29LV1024-15JC AT29LV1024-15TC	44J 48T	Commercial (0° to 70°C)
	15	0.05	AT29LV1024-15JI AT29LV1024-15TI	44J 48T	Industrial (-40° to 85°C)
200	15	0.05	AT29LV1024-20JC AT29LV1024-20TC	44J 48T	Commercial (0° to 70°C)
	15	0.10	AT29LV1024-20JI AT29LV1024-20TI	44J 48T	Industrial (-40° to 85°C)
250	15	0.05	AT29LV1024-25JC AT29LV1024-25TC	44J 48T	Commercial (0° to 70°C)
	15	0.10	AT29LV1024-25JI AT29LV1024-25TI	44J 48T	Industrial (-40° to 85°C)

Package Type	
<b>44J</b>	44-lead, Plastic J-Leaded Chip Carrier (PLCC)
<b>48T</b>	48-lead, Thin Small Outline Package (TSOP)

Packaging Information

**44J**, 44-lead, Plastic J-Leaded Chip Carrier (PLCC)  
 Dimensions in Inches and Millimeters (PLCC)  
 JEDEC STANDARD MS-018 AC

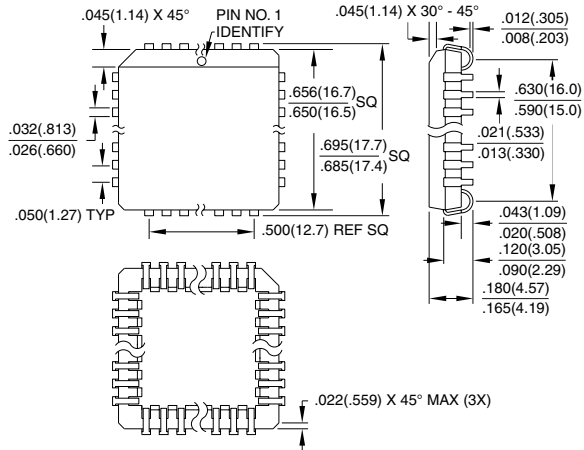

**48T**, 48-lead, Plastic Thin Small Outline Package (TSOP)  
 Dimensions in Millimeters and (Inches)\*  
 JEDEC OUTLINE MO-142 DD

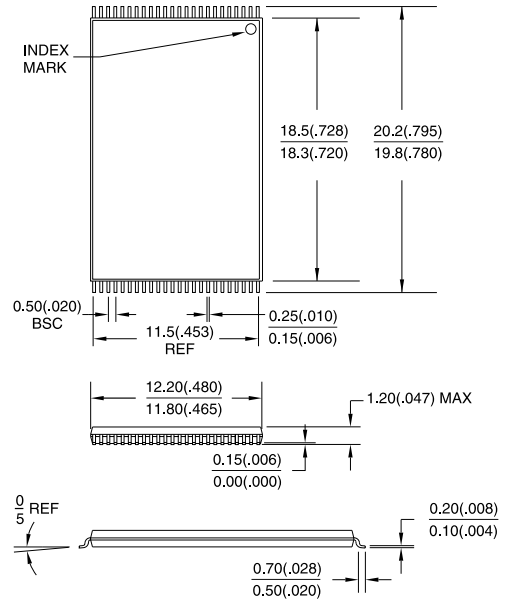

\*Controlling dimension: millimeters



## Atmel Headquarters

### *Corporate Headquarters*

2325 Orchard Parkway  
San Jose, CA 95131  
TEL (408) 441-0311  
FAX (408) 487-2600

### *Europe*

Atmel U.K., Ltd.  
Coliseum Business Centre  
Riverside Way  
Camberley, Surrey GU15 3YL  
England  
TEL (44) 1276-686-677  
FAX (44) 1276-686-697

### *Asia*

Atmel Asia, Ltd.  
Room 1219  
Chinachem Golden Plaza  
77 Mody Road Tsimhatsui  
East Kowloon  
Hong Kong  
TEL (852) 2721-9778  
FAX (852) 2722-1369

### *Japan*

Atmel Japan K.K.  
9F, Tonetsu Shinkawa Bldg.  
1-24-8 Shinkawa  
Chuo-ku, Tokyo 104-0033  
Japan  
TEL (81) 3-3523-3551  
FAX (81) 3-3523-7581

## Atmel Operations

### *Atmel Colorado Springs*

1150 E. Cheyenne Mtn. Blvd.  
Colorado Springs, CO 80906  
TEL (719) 576-3300  
FAX (719) 540-1759

### *Atmel Rousset*

Zone Industrielle  
13106 Rousset Cedex  
France  
TEL (33) 4-4253-6000  
FAX (33) 4-4253-6001

---

### *Fax-on-Demand*

North America:  
1-(800) 292-8635  
International:  
1-(408) 441-0732

### *e-mail*

[literature@atmel.com](mailto:literature@atmel.com)

### *Web Site*

<http://www.atmel.com>

### *BBS*

1-(408) 436-4309

### © Atmel Corporation 2000.

Atmel Corporation makes no warranty for the use of its products, other than those expressly contained in the Company's standard warranty which is detailed in Atmel's Terms and Conditions located on the Company's web site. The Company assumes no responsibility for any errors which may appear in this document, reserves the right to change devices or specifications detailed herein at any time without notice, and does not make any commitment to update the information contained herein. No licenses to patents or other intellectual property of Atmel are granted by the Company in connection with the sale of Atmel products, expressly or by implication. Atmel's products are not authorized for use as critical components in life support devices or systems.

Marks bearing ® and/or ™ are registered trademarks and trademarks of Atmel Corporation.

Terms and product names in this document may be trademarks of others.



Printed on recycled paper.

0564B-01/00/xM

## Looking for pricing, stock, or lifecycle information?

Click below to explore more details on WIN SOURCE:

- ⊖ [View AT29LV1024-15TC on WIN SOURCE](#)
- ⊖ [Microchip Technology](#) Information

## Optimize Your Supply Chain with WIN SOURCE Solutions

- ✓ Global Sourcing Solution
- ✓ Obsolete Management
- ✓ Cost Control Management
- ✓ Shortage Management
- ✓ Alternative Solution
- ✓ Excess Inventory Management