



**THE DATASHEET OF
MP3V5050VC6U**



MP3V5050V, -50 to 0 kPa, Gauge Pressure Sensor

The MP3V5050V piezoresistive transducer is a state-of-the-art, monolithic, signal conditioned, silicon pressure sensor. This sensor combines advanced micromachining techniques, thin film metallization, and bipolar semiconductor processing to provide an accurate, high level analog output signal that is proportional to applied pressure. The MP3V5050V is optimized to perform with vacuum pressures on the P1 port.

Features

- 2.5% maximum error over 0 °C to 85 °C
- Ideally suited for microprocessor or microcontroller-based systems
- Temperature compensated over -40 °C to +125 °C
- Patented silicon shear stress strain gauge
- Durable thermoplastic (PPS) surface mount package
- Ideal for automotive and non-automotive applications

Application examples

- Pump/motor control
- Robotics
- Level detectors
- Medical diagnostics
- Pressure switching
- Blood pressure measurement

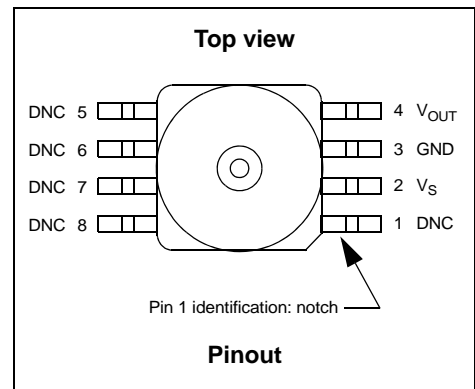
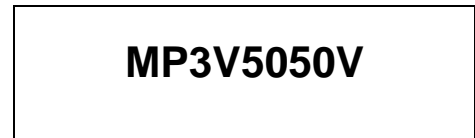

Ordering Information									
Part number	Shipping	Package	# of Ports			Pressure type			Device marking
			None	Single	Dual	Gauge	Differential	Absolute	
MP3V5050VC6U	Rail	98ASB17757C		•		•			MP3V5050V

Freescale reserves the right to change the detail specifications as may be required to permit improvements in the design of its products.

© 2008, 2010, 2015 Freescale Semiconductor, Inc. All rights reserved.



Contents

1	General Description	3
1.1	Block diagram	3
1.2	Pinout	3
2	Mechanical and Electrical Specifications	4
2.1	Maximum Ratings	4
2.2	Operating Characteristics	4
3	On-chip Temperature Compensation and Calibration	5
4	Package Information	8
4.1	Minimum recommended footprint for surface mounted applications	8
4.2	Package dimensions	9
5	Revision History	10

Related Documentation

The MP3V5050V device features and operations are described in a variety of reference manuals, user guides, and application notes. To find the most-current versions of these documents:

1. Go to the Freescale homepage at:
<http://www.freescale.com/>
2. In the Keyword search box at the top of the page, enter the device number MP3V5050V.
3. In the Refine Your Result pane on the left, click on the Documentation link.

MP3V5050V

1 General Description

1.1 Block diagram

Figure 1 shows a block diagram of the internal circuitry integrated on a pressure sensor chip.

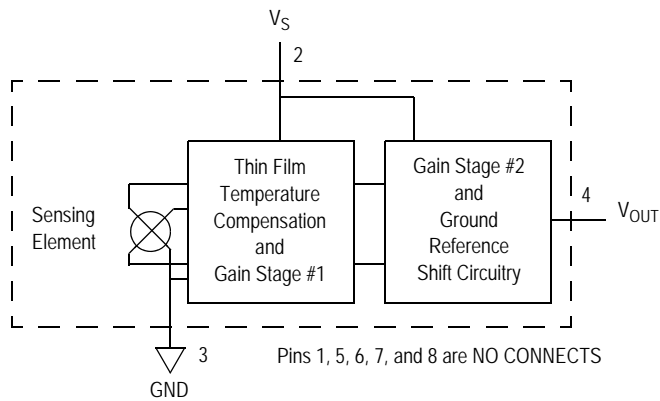

Figure 1. Fully integrated pressure sensor block diagram

1.2 Pinout

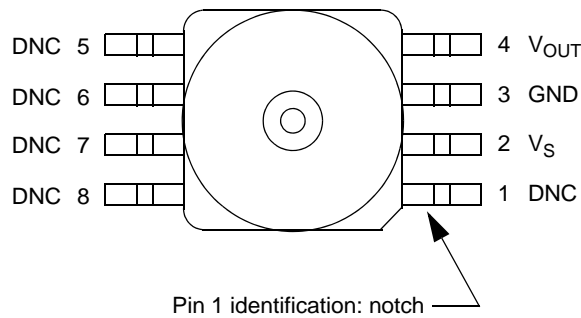

Figure 2. Device pinout (top view)

Table 1. Pin functions

Pin	Name	Function
1	DNC	Do not connect to external circuitry or ground. Pin 1 is notated by the notch in the lead.
2	V_S	Voltage supply
3	GND	Ground
4	V_{OUT}	Output voltage
5	DNC	Do not connect to external circuitry or ground.
6	DNC	Do not connect to external circuitry or ground.
7	DNC	Do not connect to external circuitry or ground.
8	DNC	Do not connect to external circuitry or ground.

2 Mechanical and Electrical Specifications

2.1 Maximum ratings

Table 2. Maximum ratings⁽¹⁾

Rating	Symbol	Value	Unit
Maximum pressure (P1 > P2)	P_{max}	200	kPa
Storage temperature	T_{stg}	-40° to +125°	°C
Operating temperature	T_A	-40° to +125°	°C

1.Exposure beyond the specified limits may cause permanent damage or degradation to the device.

2.2 Operating characteristics

Table 3. Operating characteristics ($V_S = 3.0 V_{DC}$, $T_A = 25 °C$ unless otherwise noted, $P1 > P2$)

Characteristic	Symbol	Min	Typ	Max	Unit
Pressure range	P_{OP}	-50	—	0	kPa
Supply voltage ⁽¹⁾	V_S	2.7	3.0	3.3	V_{DC}
Supply current	I_O	—	7.0	10	mA _{dc}
Full-scale output ⁽²⁾ (0° to 85°C) @ $V_S = 3.0$ Volts, ($P_{diff} = 0$ kPa)	V_{FSO}	2.7	2.8	2.9	V_{DC}
Full-scale span ⁽³⁾ (0 °C to 85 °C) @ $V_S = 3.0$ Volts	V_{FSS}	—	2.7	—	V_{DC}
Accuracy ⁽⁴⁾ (0 °C to 85 °C)	—	—	—	±2.5	% V_{FSS}
Sensitivity	V/P	—	54	—	mV/kPa
Response time ⁽⁵⁾	t_R	—	1.0	—	ms
Warm-up time ⁽⁶⁾	—	—	20	—	ms
Offset stability ⁽⁷⁾	—	—	±0.5	—	% V_{FSS}
Pressure offset ⁽⁸⁾ (0 °C to 85 °C)	V_{OFF}	0.06	0.12	0.19	V_{DC}

1.Device is ratiometric within this specified excitation range.

2.Full-scale output (V_{FSO}) is defined as the output voltage at the maximum or full-rated pressure.

3.Full-scale span (V_{FSS}) is defined as the algebraic difference between the output voltage at full-rated pressure and the output voltage at the minimum rated pressure.

4. Accuracy is the deviation in actual output from nominal output over the entire pressure range and temperature range as a percent of span at 25 °C due to all sources of errors, including the following:

Linearity: Output deviation from a straight line relationship with pressure over the specified pressure range.

Temperature hysteresis: Output deviation at any temperature within the operating temperature range, after the temperature is cycled to and from the minimum or maximum operating temperature points, with zero differential pressure applied.

Pressure hysteresis: Output deviation at any pressure within the specified range, when this pressure is cycled to and from minimum or maximum rated pressure at 25 °C.

TcSpan: Output deviation over the temperature range of 0 °C to 85 °C, relative to 25 °C.

TcOffset: Output deviation with minimum pressure applied, over the temperature range of 0 °C to 85 °C, relative to 25 °C.

5. Response time is defined as the time for the incremental change in the output to go from 10% to 90% of its final value when subjected to a specified step change in pressure.

6. Warm-up time is defined as the time required for the product to meet the specified output voltage after the pressure has been stabilized.

7. Offset stability is the product's output deviation when subjected to 1000 hours of pulsed pressure, temperature cycling with bias test.

8.Offset (V_{OFF}) is defined as the output voltage at the minimum rated pressure.

3 On-chip Temperature Compensation and Calibration

Figure 3 illustrates the differential/gauge sensing chip in the basic chip carrier.

Figure 4 shows the recommended decoupling circuit for interfacing the output of the integrated sensor to the A/D input of a microprocessor or microcontroller. Proper decoupling of the power supply is recommended.

Figure 5 shows the sensor output signal relative to pressure input. Typical minimum and maximum output curves are shown for operation over 0 °C to 85 °C temperature range. The output will saturate outside of the rated pressure range.

A fluorosilicone gel isolates the die surface and wire bonds from the environment, while allowing the pressure signal to be transmitted to the silicon diaphragm. The MP3V5050V pressure sensor operating characteristics, internal reliability and qualification tests are based on use of dry air as the pressure media. Media other than dry air may have adverse effects on sensor performance and long-term reliability. Contact the factory for information regarding media compatibility in your application.

The MP3V5050V is optimized to perform in vacuum pressures applied to port P1. The sensor is calibrated and temperature compensated to give a positive electrical output upon measuring a vacuum pressure up to the rated pressure of up to -50 kPa where the output will be the full-scale voltage listed in Table 3.

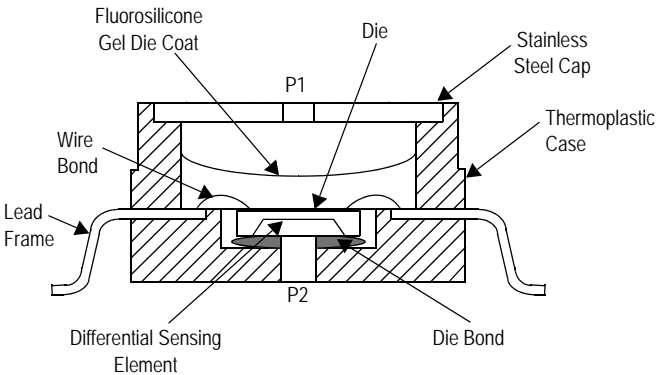

Figure 3. Cross-sectional diagram SOP (not-to-scale)

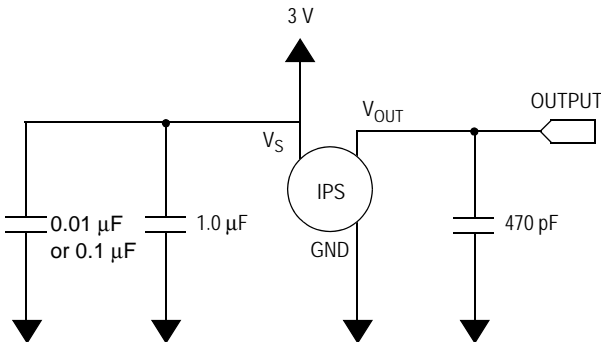

Figure 4. Recommended power supply decoupling and output filtering

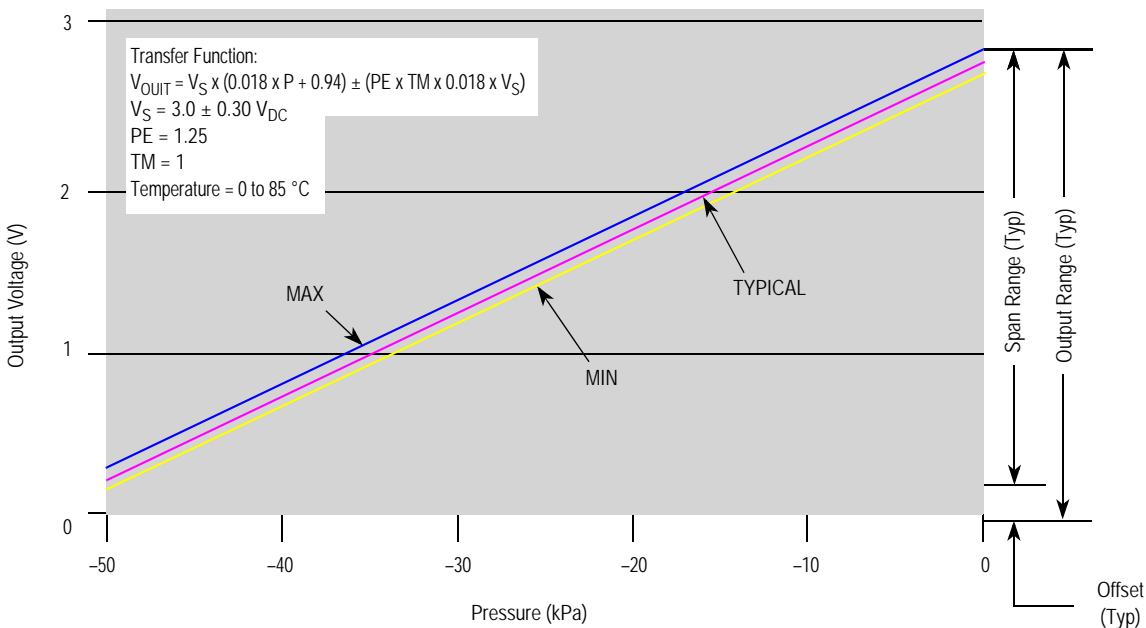
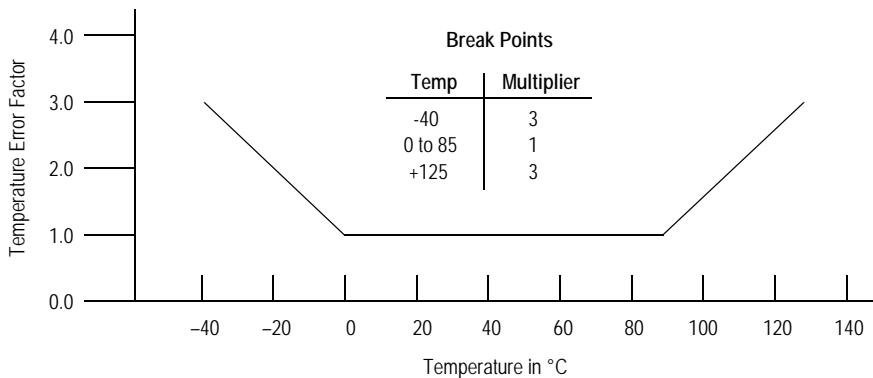

Figure 5. Output vs. pressure differential

Nominal Transfer Value: $V_{OUT} = V_S \times (0.018 \times P + 0.94) \pm (\text{Pressure Error} \times \text{Temp Multi} \times 0.018 \times V_S)$
 $V_S = 3.0 \pm 0.3 \text{ V}$

Figure 6. Transfer function



NOTE: The Temperature Multiplier is a linear response from 0 °C to -40 °C and from 85 °C to 125 °C.

Figure 7. Temperature error band

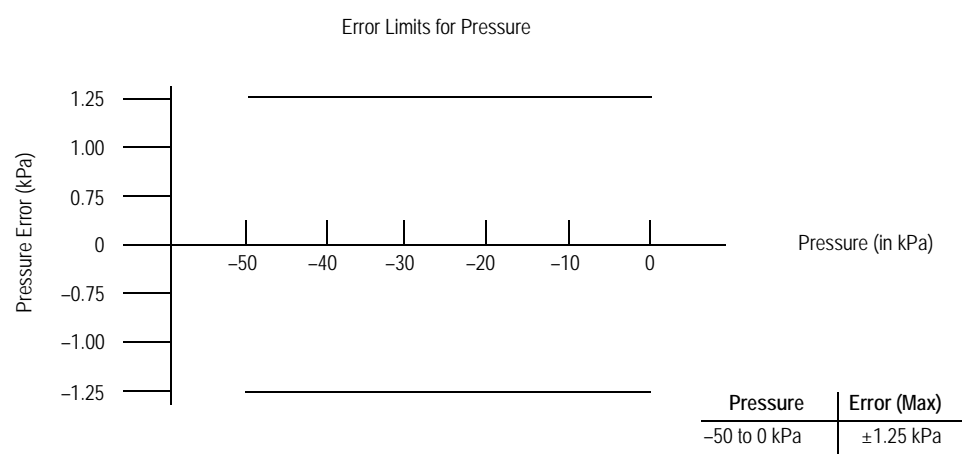
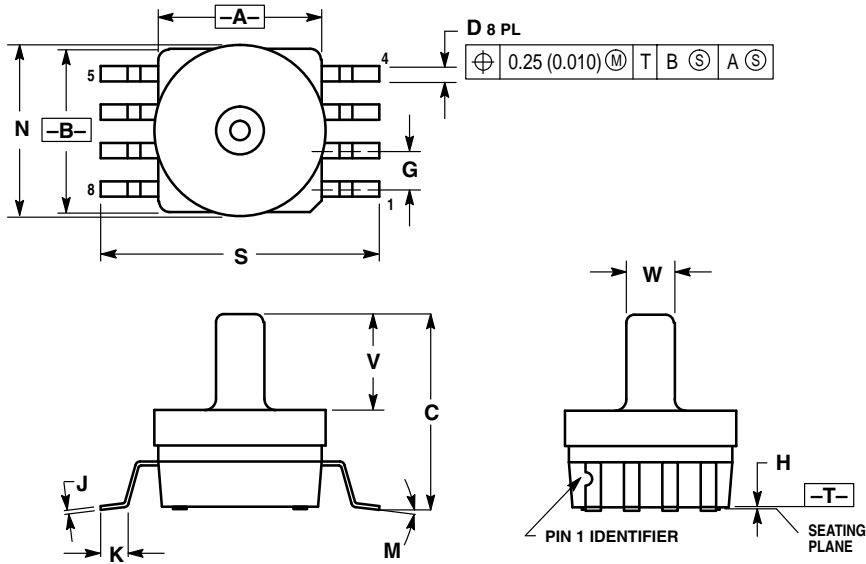

Figure 8. Pressure error band

4.2 Package dimensions

This drawing is located at http://cache.freescale.com/files/shared/doc/package_info/98ASB17757C.pdf.



DIM	INCHES		MILLIMETERS	
	MIN	MAX	MIN	MAX
A	0.415	0.425	10.54	10.79
B	0.415	0.425	10.54	10.79
C	0.500	0.520	12.70	13.21
D	0.038	0.042	0.96	1.07
G	0.100 BSC		2.54 BSC	
H	0.002	0.010	0.05	0.25
J	0.009	0.011	0.23	0.28
K	0.061	0.071	1.55	1.80
M	0°	7°	0°	7°
N	0.444	0.448	11.28	11.38
S	0.709	0.725	18.01	18.41
V	0.245	0.255	6.22	6.48
W	0.115	0.125	2.92	3.17

Case 98ASB17757C, small outline package



5 Revision History

Table 4. Revision history

Revision number	Revision date	Description
2.1	09/2015	<ul style="list-style-type: none">• Updated format.• Deleted part number MP3V5050VC6T1.• Added vacuum pressure information to section 3.



How to Reach Us:

Home Page:

freescale.com

Web Support:

freescale.com/support

Information in this document is provided solely to enable system and software implementers to use Freescale products. There are no express or implied copyright licenses granted hereunder to design or fabricate any integrated circuits based on the information in this document.

Freescale reserves the right to make changes without further notice to any products herein. Freescale makes no warranty, representation, or guarantee regarding the suitability of its products for any particular purpose, nor does Freescale assume any liability arising out of the application or use of any product or circuit, and specifically disclaims any and all liability, including without limitation consequential or incidental damages. "Typical" parameters that may be provided in Freescale data sheets and/or specifications can and do vary in different applications, and actual performance may vary over time. All operating parameters, including "typicals," must be validated for each customer application by customer's technical experts. Freescale does not convey any license under its patent rights nor the rights of others. Freescale sells products pursuant to standard terms and conditions of sale, which can be found at the following address: freescale.com/salestermsandconditions.

Freescale and the Freescale logo are trademarks of Freescale Semiconductor, Inc., Reg. U.S. Pat. & Tm. Off. All other product or service names are the property of their respective owners.

© 2008, 2010, 2015 Freescale Semiconductor, Inc.

Looking for pricing, stock, or lifecycle information?

Click below to explore more details on WIN SOURCE:

 [View MP3V5050VC6U on WIN SOURCE](#)

 [NXP / Nexperia Information](#)

Optimize Your Supply Chain with WIN SOURCE Solutions

-  Global Sourcing Solution
-  Obsolete Management
-  Cost Control Management
-  Shortage Management
-  Alternative Solution
-  Excess Inventory Management