



**THE DATASHEET OF
MAX3227CDBRG4**



FEATURES

- Meets or Exceeds the Requirements of TIA/EIA-232-F and ITU v.28 Standards
- Operates With 3-V to 5.5-V V_{CC} Supply
- Operates at Least 1 Mbit/s
- Low Standby Current . . . 1 μ A Typ
- External Capacitors . . . $4 \times 0.1 \mu$ F
- Accepts 5-V Logic Input With 3.3-V Supply
- Designed to Be Interchangeable With Maxim™ MAX3227
- Latch-Up Performance Exceeds 100 mA Per JESD 78, Class II
- ESD Protection for RS-232 I/O Pins
 - ±15 kV – Human-Body Model
 - ±8 kV – IEC61000-4-2, Contact Discharge
 - ±8 kV – IEC61000-4-2, Air-Gap Discharge
- Auto-Powerdown Plus Feature Automatically Disables Drivers for Power Savings
- Packaged in Plastic Shrink Small-Outline Package

APPLICATIONS

- Battery-Powered, Hand-Held, and Portable Equipment
- PDAs and Palmtop PCs
- Notebooks, Sub-Notebooks, and Laptops
- Digital Cameras
- Mobile Phones and Wireless Devices

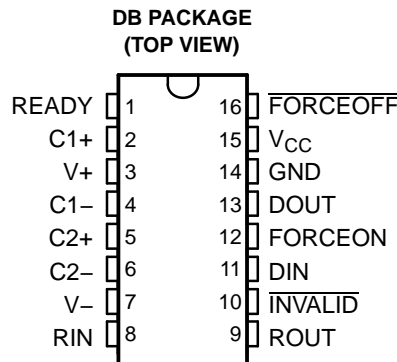

DESCRIPTION/ORDERING INFORMATION

The MAX3227 consists of one line driver, one line receiver, and a dual charge-pump circuit with ±15-kV ESD protection pin to pin (serial-port connection pins, including GND). The device meets the requirements of TIA/EIA-232-F and provides the electrical interface between an asynchronous communication controller and the serial-port connector. The charge pump and four small external capacitors allow operation from a single 3-V to 5.5-V supply. This device operates at data-signaling rates of 1 Mbit/s in normal operating mode and a maximum of 30-V/ μ s driver output slew rate. This device also features a logic-level output (READY) that asserts when the charge pump is regulating and the device is ready to begin transmitting.

The MAX3227 achieves a 1- μ A supply current using the auto-powerdown plus feature. This device automatically enters a low-power powerdown mode when the RS-232 cable is disconnected or the drivers of the connected peripherals are inactive for more than 30 s. They turn on again when they sense a valid transition at any driver or receiver input. Auto-powerdown saves power without changes to the existing BIOS or operating system.

The MAX3227C is characterized for operation from 0°C to 70°C. The MAX3227I is characterized for operation from –40°C to 85°C.

AVAILABLE OPTIONS

T_A	PACKAGED DEVICE
	SHRINK SMALL OUTLINE (DB) ⁽¹⁾
0°C to 70°C	MAX3227CDB
–40°C to 85°C	MAX3227IDB

- (1) The DB package is available taped and reeled. Add the suffix R to device type (e.g., MAX3227CDBR).



Please be aware that an important notice concerning availability, standard warranty, and use in critical applications of Texas Instruments semiconductor products and disclaimers thereto appears at the end of this data sheet.

All trademarks are the property of their respective owners.

FUNCTION TABLE⁽¹⁾

INPUT CONDITIONS				OUTPUT STATES				OPERATING MODE
FORCEON	$\overline{\text{FORCEOFF}}$	RECEIVER OR DRIVER EDGE WITHIN 30 s	VALID RS-232 LEVEL PRESENT AT RECEIVER	DRIVER	RECEIVER	$\overline{\text{INVALID}}$	READY	
Auto-Powerdown Plus Conditions								
H	H	NO	NO	Active	Active	L	H	Normal operation, auto-powerdown plus disabled
H	H	NO	YES	Active	Active	H	H	Normal operation, auto-powerdown plus disabled
L	H	YES	NO	Active	Active	L	H	Normal operation, auto-powerdown plus enabled
L	H	YES	YES	Active	Active	H	H	Normal operation, auto-powerdown plus enabled
L	H	NO	NO	Z	Active	L	L	Powerdown, auto-powerdown plus enabled
L	H	NO	YES	Z	Active	H	L	Powerdown, auto-powerdown plus enabled
X	L	X	NO	Z	Active	L	L	Manual powerdown
X	L	X	YES	Z	Active	H	L	Manual powerdown
Auto-Powerdown Conditions								
$\overline{\text{INVALID}}$	$\overline{\text{INVALID}}$	X	NO	Z	Active	L	L	Powerdown, auto-powerdown enabled
$\overline{\text{INVALID}}$	$\overline{\text{INVALID}}$	X	YES	Active	Active	H	H	Normal operation, auto-powerdown enabled

(1) H = high level, L = low level, X = irrelevant, Z = high impedance

TERMINAL FUNCTIONS

TERMINAL		DESCRIPTION
NAME	NO.	
C1+	2	Positive terminal of voltage-doubler charge-pump capacitor
C1–	4	Negative terminal of voltage-doubler charge-pump capacitor
C2+	5	Positive terminal of inverting charge-pump capacitor
C2–	6	Negative terminal of inverting charge-pump capacitor
DIN	11	CMOS driver input
DOUT	13	RS-232 driver output
$\overline{\text{FORCEOFF}}$	16	Force-off input, active low. Drive low to shut down drivers, receivers, and charge pump. This overrides auto-shutdown and FORCEON (see Function Table).
FORCEON	12	Force-on input, active high. Drive high to override powerdown, keeping drivers and receivers on (FORCEOFF must be high) (see Function Table).
GND	14	Ground
$\overline{\text{INVALID}}$	10	Valid signal detector output, active low. A logic high indicates that a valid RS-232 level is present on a receiver input.
READY	1	Ready to transmit output, active high. READY is enabled high when V– goes below –3.5 V and the device is ready to transmit.
RIN	8	RS-232 receiver input
ROUT	9	CMOS receiver output
V+	3	$+2 \times V_{CC}$ generated by the charge pump
V–	7	$-2 \times V_{CC}$ generated by the charge pump
V _{CC}	15	3-V to 5.5-V single-supply voltage

LOGIC DIAGRAM (POSITIVE LOGIC)

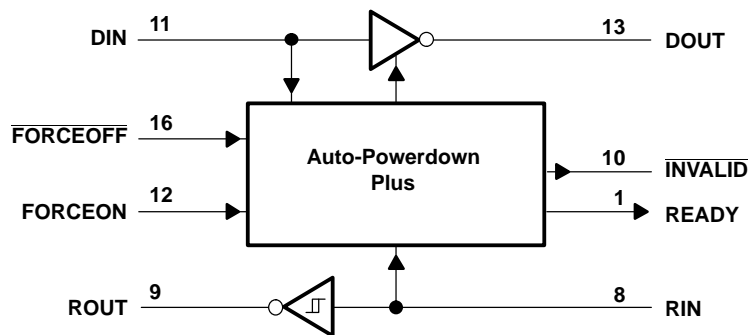

MAX3227

3-V TO 5.5-V SINGLE-CHANNEL RS-232 LINE DRIVER/RECEIVER WITH ± 15 -kV ESD PROTECTION

SLLS673A–AUGUST 2005–REVISED FEBRUARY 2006

Absolute Maximum Ratings⁽¹⁾

over operating free-air temperature range (unless otherwise noted)

		MIN	MAX	UNIT	
V_{CC}	Supply voltage range ⁽²⁾	-0.3	6	V	
V+	Positive output supply voltage range ⁽²⁾	-0.3	7	V	
V-	Negative output supply voltage range ⁽²⁾	0.3	-7	V	
V+ - V-	Supply voltage difference ⁽²⁾		13	V	
V_I	Input voltage range	Driver ($\overline{\text{FORCEOFF}}$, FORCEON)	-0.3	6	V
		Receiver	-25	25	
V_O	Output voltage range	Driver	-13.2	13.2	V
		Receiver ($\overline{\text{INVALID}}$, READY)	-0.3	$V_{CC} + 0.3$	
	Short-circuit duration	DOUT to GND		Unlimited	
θ_{JA}	Package thermal impedance ⁽³⁾		82	$^{\circ}\text{C}/\text{W}$	
		Lead temperature 1,6 mm (1/16 in) from case for 10 s	260	$^{\circ}\text{C}$	
T_{stg}	Storage temperature range	-65	150	$^{\circ}\text{C}$	

- (1) Stresses beyond those listed under "absolute maximum ratings" may cause permanent damage to the device. These are stress ratings only, and functional operation of the device at these or any other conditions beyond those indicated under "recommended operating conditions" is not implied. Exposure to absolute-maximum-rated conditions for extended periods may affect device reliability.
- (2) All voltages are with respect to network GND.
- (3) The package thermal impedance is calculated in accordance with JESD 51-7.

Recommended Operating Conditions⁽¹⁾

See [Figure 5](#)

		MIN	NOM	MAX	UNIT	
Supply voltage	$V_{CC} = 3.3 \text{ V}$	3	3.3	3.6	V	
	$V_{CC} = 5 \text{ V}$	4.5	5	5.5		
V_{IH}	Driver and control high-level input voltage	DIN, $\overline{\text{FORCEOFF}}$, FORCEON	$V_{CC} = 3.3 \text{ V}$	2	5.5	V
			$V_{CC} = 5 \text{ V}$	2.4	5.5	
V_{IL}	Driver and control low-level input voltage	DIN, $\overline{\text{FORCEOFF}}$, FORCEON		0	0.8	V
V_I	Receiver input voltage	-25		25	V	
T_A	Operating free-air temperature	MAX3227C	0	70	$^{\circ}\text{C}$	
		MAX3227I	-40	85		

- (1) Test conditions are C1–C4 = 0.1 μF at $V_{CC} = 3.3 \text{ V} \pm 0.3 \text{ V}$; C1 = 0.047 μF , C2–C4 = 0.33 μF at $V_{CC} = 5 \text{ V} \pm 0.5 \text{ V}$.

Electrical Characteristics⁽¹⁾

over recommended ranges of supply voltage and operating free-air temperature (unless otherwise noted) (see [Figure 5](#))

PARAMETER		TEST CONDITIONS	MIN	TYP ⁽²⁾	MAX	UNIT
I_I	Input leakage current	$\overline{\text{FORCEOFF}}$, FORCEON		± 0.01	± 1	μA
I_{CC}	Supply current ($T_A = 25^{\circ}\text{C}$)	Auto-powerdown plus disabled	No load, $\overline{\text{FORCEOFF}}$ and FORCEON at V_{CC}	0.3	2	mA
		Powered off	No load, $\overline{\text{FORCEOFF}}$ at GND	1	10	
		Auto-powerdown plus enabled	No load, $\overline{\text{FORCEOFF}}$ at V_{CC} , FORCEON at GND, All RIN are open or grounded	1	10	μA

- (1) Test conditions are C1–C4 = 0.1 μF at $V_{CC} = 3.3 \text{ V} \pm 0.3 \text{ V}$; C1 = 0.047 μF , C2–C4 = 0.33 μF at $V_{CC} = 5 \text{ V} \pm 0.5 \text{ V}$.
- (2) All typical values are at $V_{CC} = 3.3 \text{ V}$ or $V_{CC} = 5 \text{ V}$, and $T_A = 25^{\circ}\text{C}$.

DRIVER SECTION

Electrical Characteristics⁽¹⁾

over recommended ranges of supply voltage and operating free-air temperature (unless otherwise noted)
(see [Figure 1](#) and [Figure 2](#))

PARAMETER		TEST CONDITIONS	MIN	TYP ⁽²⁾	MAX	UNIT
V _{OH}	High-level output voltage	DOUT at R _L = 3 k Ω to GND, DIN = GND	5	5.4		V
V _{OL}	Low-level output voltage	DOUT at R _L = 3 k Ω to GND, DIN = V _{CC}	–5	–5.4		V
I _{IH}	High-level input current	V _I = V _{CC}		± 0.01	± 1	μ A
I _{IL}	Low-level input current	V _I at GND		± 0.01	± 1	μ A
I _{OS}	Short-circuit output current ⁽³⁾	V _{CC} = 3.6 V, V _O = 0 V		± 35	± 60	mA
		V _{CC} = 5.5 V, V _O = 0 V		± 35	± 60	
r _o	Output resistance	V _{CC} , V ₊ , and V _– = 0 V, V _O = ± 2 V	300	10M		Ω
I _{off}	Output leakage current	$\overline{\text{FORCEOFF}}$ = GND, V _O = ± 12 V, V _{CC} = 0 to 5.5 V			± 25	μ A

(1) Test conditions are C1–C4 = 0.1 μ F at V_{CC} = 3.3 V \pm 0.3 V; C1 = 0.047 μ F, C2–C4 = 0.33 μ F at V_{CC} = 5 V \pm 0.5 V.

(2) All typical values are at V_{CC} = 3.3 V or V_{CC} = 5 V, and T_A = 25°C.

(3) Short-circuit durations should be controlled to prevent exceeding the device absolute power dissipation ratings, and not more than one output should be shorted at a time.

Switching Characteristics⁽¹⁾

over recommended ranges of supply voltage and operating free-air temperature (unless otherwise noted)
(see [Figure 1](#) and [Figure 2](#))

PARAMETER		TEST CONDITIONS	MIN	TYP ⁽²⁾	MAX	UNIT
Maximum data rate		C _L = 1000 pF, R _L = 3 k Ω , One DIN switching, See Figure 1	250			kbit/s
		C _L = 1000 pF, R _L = 3 k Ω , V _{CC} = 4.5 V, See Figure 1	1000			
		C _L = 250 pF, R _L = 3 k Ω , V _{CC} = 3 V, See Figure 1	1000			
t _{sk(p)}	Pulse skew ⁽³⁾	C _L = 150 pF to 2500 pF, R _L = 3 k Ω to 7 k Ω , See Figure 2		25		ns
SR(tr)	Slew rate, transition region	V _{CC} = 3.3 V, R _L = 3 k Ω to 7 k Ω , C _L = 150 pF to 1000 pF, See Figure 1	24		150	V/ μ s

(1) Test conditions are C1–C4 = 0.1 μ F at V_{CC} = 3.3 V \pm 0.3 V; C1 = 0.047 μ F, C2–C4 = 0.33 μ F at V_{CC} = 5 V \pm 0.5 V.

(2) All typical values are at V_{CC} = 3.3 V or V_{CC} = 5 V, and T_A = 25°C.

(3) Pulse skew is defined as |t_{PLH} – t_{PHL}| of each channel of the same device.

ESD Protection

TERMINAL		TEST CONDITIONS	TYP	UNIT
NAME	NO.			
DOUT	13	Human-Body Model	± 15	kV
		Contact Discharge (IEC61000-4-2)	± 8	
		Air-Gap Discharge (IEC61000-4-2)	± 8	

MAX3227

3-V TO 5.5-V SINGLE-CHANNEL RS-232 LINE DRIVER/RECEIVER WITH ± 15 -kV ESD PROTECTION

SLLS673A – AUGUST 2005 – REVISED FEBRUARY 2006

RECEIVER SECTION

Electrical Characteristics⁽¹⁾

over recommended ranges of supply voltage and operating free-air temperature (unless otherwise noted) (see [Figure 3](#))

PARAMETER		TEST CONDITIONS	MIN	TYP ⁽²⁾	MAX	UNIT
V_{OH}	High-level output voltage	$I_{OH} = -1$ mA	$V_{CC} - 0.6$	$V_{CC} - 0.1$		V
V_{OL}	Low-level output voltage	$I_{OL} = 1.6$ mA			0.4	V
V_{IT+}	Positive-going input threshold voltage	$V_{CC} = 3.3$ V		1.5	2.4	V
		$V_{CC} = 5$ V		1.8	2.4	
V_{IT-}	Negative-going input threshold voltage	$V_{CC} = 3.3$ V	0.6	1.2		V
		$V_{CC} = 5$ V	0.8	1.5		
V_{hys}	Input hysteresis ($V_{IT+} - V_{IT-}$)			0.5		V
I_{off}	Output leakage current			± 0.05	± 10	μ A
r_i	Input resistance	$V_I = \pm 3$ V to ± 25 V	3	5	7	k Ω

(1) Test conditions are C1–C4 = 0.1 μ F at $V_{CC} = 3.3$ V \pm 0.3 V; C1 = 0.047 μ F, C2–C4 = 0.33 μ F at $V_{CC} = 5$ V \pm 0.5 V.

(2) All typical values are at $V_{CC} = 3.3$ V or $V_{CC} = 5$ V, and $T_A = 25^\circ$ C.

Switching Characteristics⁽¹⁾

over recommended ranges of supply voltage and operating free-air temperature (unless otherwise noted)

PARAMETER		TEST CONDITIONS	TYP ⁽²⁾	UNIT
t_{PLH}	Propagation delay time, low- to high-level output	$C_L = 150$ pF, See Figure 3	150	ns
t_{PHL}	Propagation delay time, high- to low-level output	$C_L = 150$ pF, See Figure 3	150	ns
$t_{sk(p)}$	Pulse skew ⁽³⁾	See Figure 3	50	ns

(1) Test conditions are C1–C4 = 0.1 μ F at $V_{CC} = 3.3$ V \pm 0.3 V; C1 = 0.047 μ F, C2–C4 = 0.33 μ F at $V_{CC} = 5$ V \pm 0.5 V.

(2) All typical values are at $V_{CC} = 3.3$ V or $V_{CC} = 5$ V, and $T_A = 25^\circ$ C.

(3) Pulse skew is defined as $|t_{PLH} - t_{PHL}|$ of each channel of the same device.

ESD Protection

TERMINAL		TEST CONDITIONS	TYP	UNIT
NAME	NO.			
RIN	8	Human-Body Model	± 15	kV
		Contact Discharge (IEC61000-4-2)	± 8	
		Air-Gap Discharge (IEC61000-4-2)	± 15	

AUTO-POWERDOWN SECTION

Electrical Characteristics

over recommended ranges of supply voltage and operating free-air temperature (unless otherwise noted) (see [Figure 4](#))

PARAMETER		TEST CONDITIONS	MIN	MAX	UNIT
V_{T+} (valid)	Receiver input threshold for $\overline{\text{INVALID}}$ high-level output voltage	FORCEON = GND, $\overline{\text{FORCEOFF}} = V_{CC}$		2.7	V
V_{T-} (valid)	Receiver input threshold for $\overline{\text{INVALID}}$ high-level output voltage	FORCEON = GND, $\overline{\text{FORCEOFF}} = V_{CC}$	–2.7		V
V_{T} (invalid)	Receiver input threshold for $\overline{\text{INVALID}}$ low-level output voltage	FORCEON = GND, $\overline{\text{FORCEOFF}} = V_{CC}$	–0.3	0.3	V
V_{OH}	$\overline{\text{INVALID}}$, READY output voltage high	$I_{OH} = -1$ mA, FORCEON = GND, $\overline{\text{FORCEOFF}} = V_{CC}$	$V_{CC} - 0.6$		V
V_{OL}	$\overline{\text{INVALID}}$, READY output voltage low	$I_{OL} = 1.6$ mA, FORCEON = GND, $\overline{\text{FORCEOFF}} = V_{CC}$		0.4	V

Switching Characteristics

over recommended ranges of supply voltage and operating free-air temperature (unless otherwise noted) (see [Figure 4](#))

PARAMETER		MIN	TYP ⁽¹⁾	MAX	UNIT	
t_{INVH}	Propagation delay time, low- to high-level output		1		μs	
t_{INVL}	Propagation delay time, high- to low-level output		30		μs	
t_{WU}	Supply enable time		100		μs	
t_{AUTOPRDN}	Driver or receiver edge to driver's shutdown	$V_{CC} = 5$ V	15	30	60	s

(1) All typical values are at $V_{CC} = 3.3$ V or $V_{CC} = 5$ V, and $T_A = 25^\circ\text{C}$.

PARAMETER MEASUREMENT INFORMATION

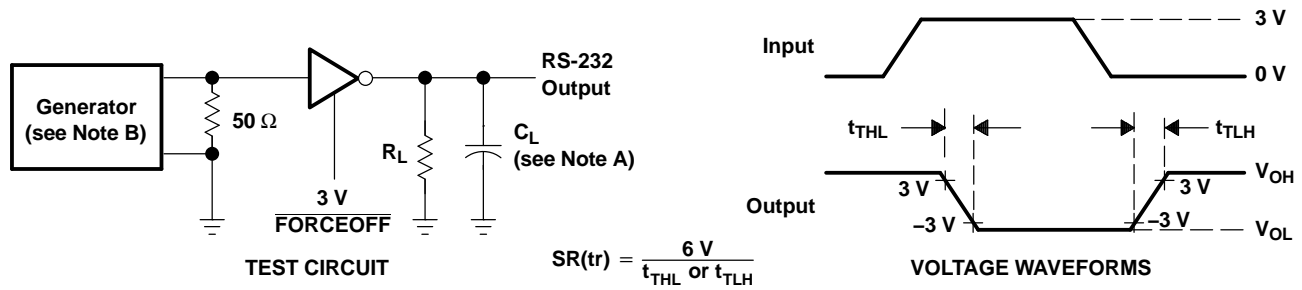

NOTES: A. C_L includes probe and jig capacitance.
 B. The pulse generator has the following characteristics: PRR = 250 kbit/s, $Z_O = 50\ \Omega$, 50% duty cycle, $t_r \leq 10\text{ ns}$, $t_f \leq 10\text{ ns}$.

Figure 1. Driver Slew Rate

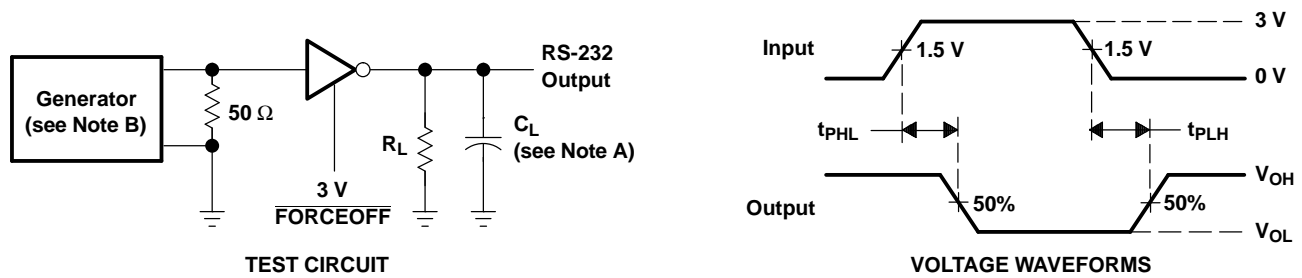

NOTES: A. C_L includes probe and jig capacitance.
 B. The pulse generator has the following characteristics: PRR = 250 kbit/s, $Z_O = 50\ \Omega$, 50% duty cycle, $t_r \leq 10\text{ ns}$, $t_f \leq 10\text{ ns}$.

Figure 2. Driver Pulse Skew

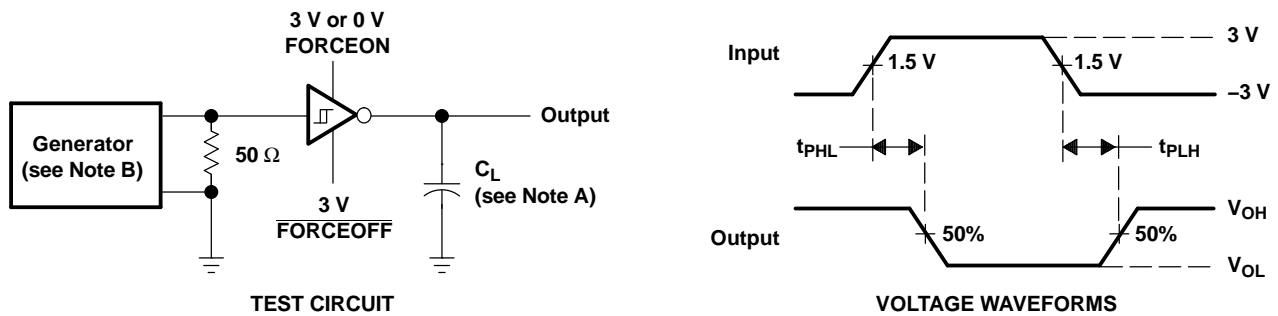

NOTES: A. C_L includes probe and jig capacitance.
 B. The pulse generator has the following characteristics: $Z_O = 50\ \Omega$, 50% duty cycle, $t_r \leq 10\text{ ns}$, $t_f \leq 10\text{ ns}$.

Figure 3. Receiver Propagation Delay Times

PARAMETER MEASUREMENT INFORMATION (continued)

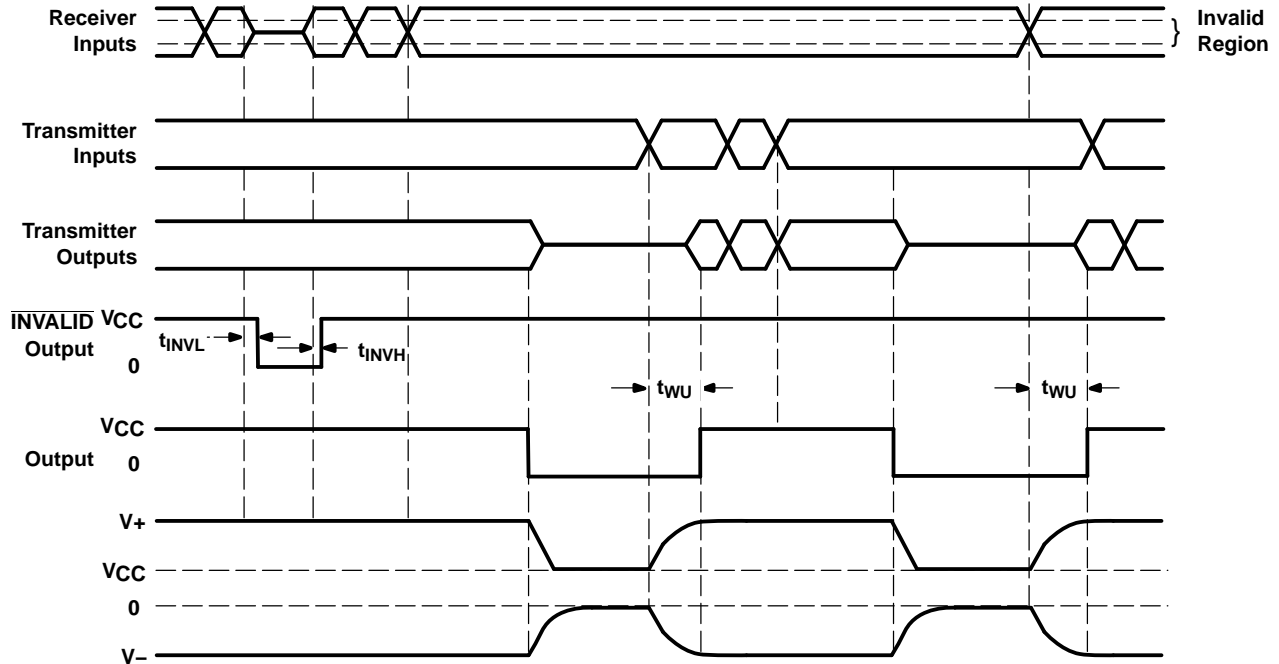

VOLTAGE WAVEFORMS

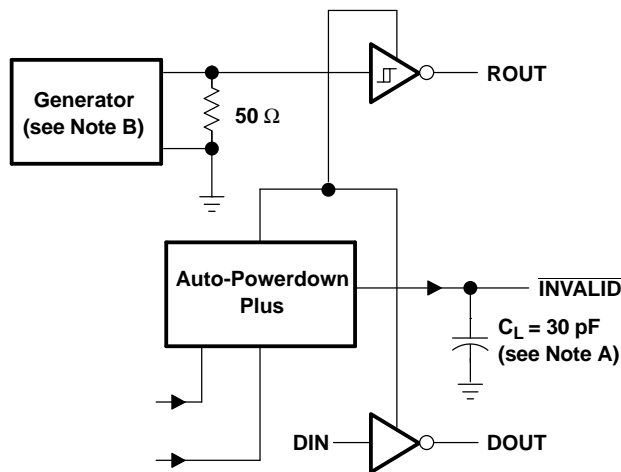

TEST CIRCUIT

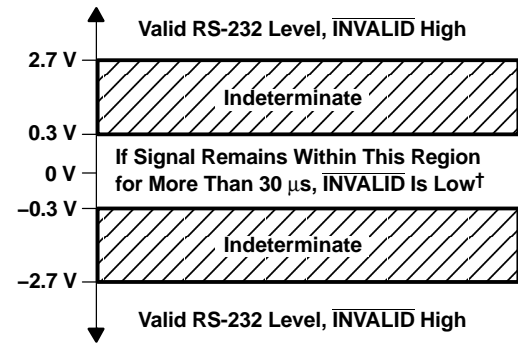

† Auto-powerdown disables drivers and reduces supply current to 1 μ A.

Figure 4. $\overline{\text{INVALID}}$ Propagation Delay Times and Driver Enabling Time

APPLICATION INFORMATION

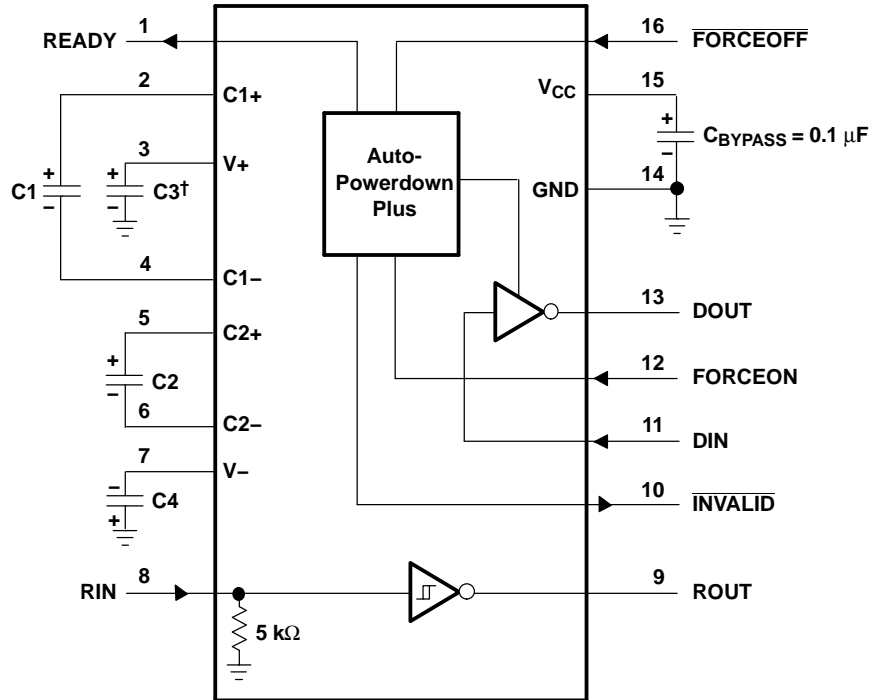

† C3 can be connected to V_{CC} or GND.

NOTES: A. Resistor values shown are nominal.

B. Nonpolarized ceramic capacitors are acceptable. If polarized tantalum or electrolytic capacitors are used, they should be connected as shown.

V_{CC} vs CAPACITOR VALUES

V _{CC}	C1	C2, C3, and C4
3.3 V ± 0.3 V	0.1 μF	0.1 μF
5 V ± 0.5 V	0.047 μF	0.33 μF
3 V to 5.5 V	0.1 μF	0.47 μF

Figure 5. Typical Operating Circuit and Capacitor Values

PACKAGING INFORMATION

Orderable Device	Status ⁽¹⁾	Package Type	Package Drawing	Pins	Package Qty	Eco Plan ⁽²⁾	Lead/Ball Finish	MSL Peak Temp ⁽³⁾
MAX3227CDB	ACTIVE	SSOP	DB	16	80	Green (RoHS & no Sb/Br)	CU NIPDAU	Level-1-260C-UNLIM
MAX3227CDBE4	ACTIVE	SSOP	DB	16	80	Green (RoHS & no Sb/Br)	CU NIPDAU	Level-1-260C-UNLIM
MAX3227CDBG4	ACTIVE	SSOP	DB	16	80	Green (RoHS & no Sb/Br)	CU NIPDAU	Level-1-260C-UNLIM
MAX3227CDBR	ACTIVE	SSOP	DB	16	2000	Green (RoHS & no Sb/Br)	CU NIPDAU	Level-1-260C-UNLIM
MAX3227CDBRE4	ACTIVE	SSOP	DB	16	2000	Green (RoHS & no Sb/Br)	CU NIPDAU	Level-1-260C-UNLIM
MAX3227CDBRG4	ACTIVE	SSOP	DB	16	2000	Green (RoHS & no Sb/Br)	CU NIPDAU	Level-1-260C-UNLIM
MAX3227IDB	ACTIVE	SSOP	DB	16	80	Green (RoHS & no Sb/Br)	CU NIPDAU	Level-1-260C-UNLIM
MAX3227IDBE4	ACTIVE	SSOP	DB	16	80	Green (RoHS & no Sb/Br)	CU NIPDAU	Level-1-260C-UNLIM
MAX3227IDBG4	ACTIVE	SSOP	DB	16	80	Green (RoHS & no Sb/Br)	CU NIPDAU	Level-1-260C-UNLIM
MAX3227IDBR	ACTIVE	SSOP	DB	16	2000	Green (RoHS & no Sb/Br)	CU NIPDAU	Level-1-260C-UNLIM
MAX3227IDBRE4	ACTIVE	SSOP	DB	16	2000	Green (RoHS & no Sb/Br)	CU NIPDAU	Level-1-260C-UNLIM
MAX3227IDBRG4	ACTIVE	SSOP	DB	16	2000	Green (RoHS & no Sb/Br)	CU NIPDAU	Level-1-260C-UNLIM

⁽¹⁾ The marketing status values are defined as follows:

ACTIVE: Product device recommended for new designs.

LIFEBUY: TI has announced that the device will be discontinued, and a lifetime-buy period is in effect.

NRND: Not recommended for new designs. Device is in production to support existing customers, but TI does not recommend using this part in a new design.

PREVIEW: Device has been announced but is not in production. Samples may or may not be available.

OBSOLETE: TI has discontinued the production of the device.

⁽²⁾ Eco Plan - The planned eco-friendly classification: Pb-Free (RoHS), Pb-Free (RoHS Exempt), or Green (RoHS & no Sb/Br) - please check <http://www.ti.com/productcontent> for the latest availability information and additional product content details.

TBD: The Pb-Free/Green conversion plan has not been defined.

Pb-Free (RoHS): TI's terms "Lead-Free" or "Pb-Free" mean semiconductor products that are compatible with the current RoHS requirements for all 6 substances, including the requirement that lead not exceed 0.1% by weight in homogeneous materials. Where designed to be soldered at high temperatures, TI Pb-Free products are suitable for use in specified lead-free processes.

Pb-Free (RoHS Exempt): This component has a RoHS exemption for either 1) lead-based flip-chip solder bumps used between the die and package, or 2) lead-based die adhesive used between the die and leadframe. The component is otherwise considered Pb-Free (RoHS compatible) as defined above.

Green (RoHS & no Sb/Br): TI defines "Green" to mean Pb-Free (RoHS compatible), and free of Bromine (Br) and Antimony (Sb) based flame retardants (Br or Sb do not exceed 0.1% by weight in homogeneous material)

⁽³⁾ MSL, Peak Temp. -- The Moisture Sensitivity Level rating according to the JEDEC industry standard classifications, and peak solder temperature.

Important Information and Disclaimer: The information provided on this page represents TI's knowledge and belief as of the date that it is provided. TI bases its knowledge and belief on information provided by third parties, and makes no representation or warranty as to the accuracy of such information. Efforts are underway to better integrate information from third parties. TI has taken and continues to take reasonable steps to provide representative and accurate information but may not have conducted destructive testing or chemical analysis on incoming materials and chemicals. TI and TI suppliers consider certain information to be proprietary, and thus CAS numbers and other limited information may not be available for release.

In no event shall TI's liability arising out of such information exceed the total purchase price of the TI part(s) at issue in this document sold by TI to Customer on an annual basis.

TAPE AND REEL INFORMATION



QUADRANT ASSIGNMENTS FOR PIN 1 ORIENTATION IN TAPE

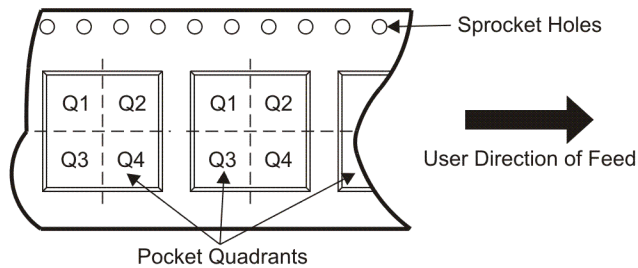

*All dimensions are nominal

Device	Package Type	Package Drawing	Pins	SPQ	Reel Diameter (mm)	Reel Width W1 (mm)	A0 (mm)	B0 (mm)	K0 (mm)	P1 (mm)	W (mm)	Pin1 Quadrant
MAX3227CDBR	SSOP	DB	16	2000	330.0	16.4	8.2	6.6	2.5	12.0	16.0	Q1
MAX3227IDBR	SSOP	DB	16	2000	330.0	16.4	8.2	6.6	2.5	12.0	16.0	Q1

TAPE AND REEL BOX DIMENSIONS



*All dimensions are nominal

Device	Package Type	Package Drawing	Pins	SPQ	Length (mm)	Width (mm)	Height (mm)
MAX3227CDBR	SSOP	DB	16	2000	346.0	346.0	33.0
MAX3227IDBR	SSOP	DB	16	2000	346.0	346.0	33.0

DB (R-PDSO-G**)

PLASTIC SMALL-OUTLINE

28 PINS SHOWN



- NOTES: A. All linear dimensions are in millimeters.
 B. This drawing is subject to change without notice.
 C. Body dimensions do not include mold flash or protrusion not to exceed 0,15.
 D. Falls within JEDEC MO-150

IMPORTANT NOTICE

Texas Instruments Incorporated and its subsidiaries (TI) reserve the right to make corrections, modifications, enhancements, improvements, and other changes to its products and services at any time and to discontinue any product or service without notice. Customers should obtain the latest relevant information before placing orders and should verify that such information is current and complete. All products are sold subject to TI's terms and conditions of sale supplied at the time of order acknowledgment.

TI warrants performance of its hardware products to the specifications applicable at the time of sale in accordance with TI's standard warranty. Testing and other quality control techniques are used to the extent TI deems necessary to support this warranty. Except where mandated by government requirements, testing of all parameters of each product is not necessarily performed.

TI assumes no liability for applications assistance or customer product design. Customers are responsible for their products and applications using TI components. To minimize the risks associated with customer products and applications, customers should provide adequate design and operating safeguards.

TI does not warrant or represent that any license, either express or implied, is granted under any TI patent right, copyright, mask work right, or other TI intellectual property right relating to any combination, machine, or process in which TI products or services are used. Information published by TI regarding third-party products or services does not constitute a license from TI to use such products or services or a warranty or endorsement thereof. Use of such information may require a license from a third party under the patents or other intellectual property of the third party, or a license from TI under the patents or other intellectual property of TI.

Reproduction of TI information in TI data books or data sheets is permissible only if reproduction is without alteration and is accompanied by all associated warranties, conditions, limitations, and notices. Reproduction of this information with alteration is an unfair and deceptive business practice. TI is not responsible or liable for such altered documentation. Information of third parties may be subject to additional restrictions.

Resale of TI products or services with statements different from or beyond the parameters stated by TI for that product or service voids all express and any implied warranties for the associated TI product or service and is an unfair and deceptive business practice. TI is not responsible or liable for any such statements.

TI products are not authorized for use in safety-critical applications (such as life support) where a failure of the TI product would reasonably be expected to cause severe personal injury or death, unless officers of the parties have executed an agreement specifically governing such use. Buyers represent that they have all necessary expertise in the safety and regulatory ramifications of their applications, and acknowledge and agree that they are solely responsible for all legal, regulatory and safety-related requirements concerning their products and any use of TI products in such safety-critical applications, notwithstanding any applications-related information or support that may be provided by TI. Further, Buyers must fully indemnify TI and its representatives against any damages arising out of the use of TI products in such safety-critical applications.

TI products are neither designed nor intended for use in military/aerospace applications or environments unless the TI products are specifically designated by TI as military-grade or "enhanced plastic." Only products designated by TI as military-grade meet military specifications. Buyers acknowledge and agree that any such use of TI products which TI has not designated as military-grade is solely at the Buyer's risk, and that they are solely responsible for compliance with all legal and regulatory requirements in connection with such use.

TI products are neither designed nor intended for use in automotive applications or environments unless the specific TI products are designated by TI as compliant with ISO/TS 16949 requirements. Buyers acknowledge and agree that, if they use any non-designated products in automotive applications, TI will not be responsible for any failure to meet such requirements.

Following are URLs where you can obtain information on other Texas Instruments products and application solutions:

Products

Amplifiers	amplifier.ti.com
Data Converters	dataconverter.ti.com
DLP® Products	www.dlp.com
DSP	dsp.ti.com
Clocks and Timers	www.ti.com/clocks
Interface	interface.ti.com
Logic	logic.ti.com
Power Mgmt	power.ti.com
Microcontrollers	microcontroller.ti.com
RFID	www.ti-rfid.com
RF/IF and ZigBee® Solutions	www.ti.com/lprf

Applications

Audio	www.ti.com/audio
Automotive	www.ti.com/automotive
Broadband	www.ti.com/broadband
Digital Control	www.ti.com/digitalcontrol
Medical	www.ti.com/medical
Military	www.ti.com/military
Optical Networking	www.ti.com/opticalnetwork
Security	www.ti.com/security
Telephony	www.ti.com/telephony
Video & Imaging	www.ti.com/video
Wireless	www.ti.com/wireless

Mailing Address: Texas Instruments, Post Office Box 655303, Dallas, Texas 75265
Copyright © 2009, Texas Instruments Incorporated

Looking for pricing, stock, or lifecycle information?

Click below to explore more details on WIN SOURCE:

 [View MAX3227CDBRG4 on WIN SOURCE](#)

 [Texas Instruments](#) Information

Optimize Your Supply Chain with WIN SOURCE Solutions

-  Global Sourcing Solution
-  Obsolete Management
-  Cost Control Management
-  Shortage Management
-  Alternative Solution
-  Excess Inventory Management