

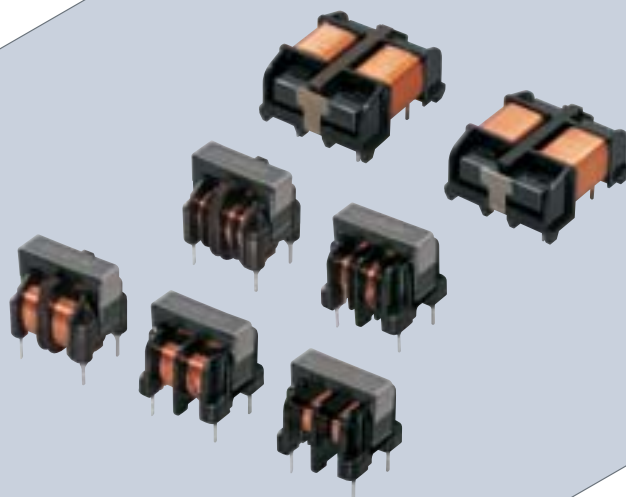

**THE DATASHEET OF
PLY17BS1023R0A2B**



EMI Suppression Filters (EMIFIL[®]) for AC Power Lines





EU RoHS Compliant

- All the products in this catalog comply with EU RoHS.
- EU RoHS is "the European Directive 2011/65/EU on the Restriction of the Use of Certain Hazardous Substances in Electrical and Electronic Equipment."
- For more details, please refer to our website 'Murata's Approach for EU RoHS' (<http://www.murata.com/en-eu/support/compliance/rohs>).

Contents

Product specifications are as of October 2016.

EMIFIL® in this catalog is the trademark of Murata Manufacturing Co., Ltd.

Part Numbering	p2
Outline of EMI Suppression Filter (EMIFIL®) for AC Power Lines	p3
<hr/>	
1 Common Mode Choke Coil	p5
PLA10 Series Standard Winding	p5
PLA10 Series Sectional Winding	p5
PLA10 Series (Safety Standard Recognized) Standard Winding	p7
PLA10 Series (Safety Standard Recognized) Sectional Winding	p7
PLA10 Series High Inductance Standard Winding	p9
PLA10 Series High Inductance Sectional Winding	p9
PLA10 Series High Inductance (Safety Standard Recognized) Standard Winding ...	p11
PLA10 Series High Inductance (Safety Standard Recognized) Sectional Winding ...	p11
PLH10 Series	p13
PLH10 Series (Safety Standard Recognized)	p14
<hr/>	
2 Hybrid Choke Coil	p15
PLY10 Series Standard Winding	p15
PLY10 Series Sectional Winding	p15
PLY10 Series (Safety Standard Recognized) Standard Winding	p17
PLY10 Series (Safety Standard Recognized) Sectional Winding	p17
PLY10 Series High Inductance Standard Winding	p19
PLY10 Series High Inductance Sectional Winding	p19
PLY10 Series High Inductance (Safety Standard Recognized) Standard Winding ...	p21
PLY10 Series High Inductance (Safety Standard Recognized) Sectional Winding ...	p21
PLY17 Series A Type	p23
PLY17 Series B Type	p23
PLY17 Series (Safety Standard Recognized) A Type	p25
PLY17 Series (Safety Standard Recognized) B Type	p25
Noise Suppression Effect of PLY10 Series	p27
<hr/>	
⚠Caution/Notice	p28
Packaging	p29

Please check the MURATA website (<http://www.murata.com/>) if you cannot find a part number in this catalog.

● Part Numbering

AC Line Filters

(Part Number)

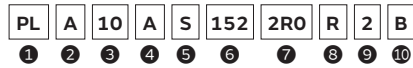

① Product ID

Product ID	
PL	Common Mode Choke Coils

② Type

Code	Type
A	AC Standard
H	AC High-frequency
Y	AC Hybrid Choke Coils

③ Applications

Code	Applications
10	for AC Line
17	

④ Structure

Code	Structure
A	Core Vertical
B	Core Horizontal

⑤ Features

Code	Features
S	Safety Recognized
N	General Use
H	High Inductance
V	High Inductance Safety Recognized

⑥ Inductance

Expressed by three figures. The unit is micro-henry (μH). The first and second figures are significant digits, and the third figure expresses the number of zeros that follow the two figures.

⑦ Rated Current

Expressed by three-digit alphanumerics. The unit is amperes (A). A decimal point is expressed by the capital letter "R." In this case, all figures are significant digits.

⑧ Winding Mode

Code	Winding Mode
A	Parallel Winding
B	Parallel Winding (High-Performance)
D	Sectional Winding
R	Standard
P	Single Layer Winding

⑨ Lead Dimensions

Code	Lead Dimensions
2	3.5mm

⑩ Packaging

Code	Packaging	Series
B	Bulk	All series

Outline of EMI Suppression Filter (EMIFIL[®]) for AC Power Lines





EMI (Electromagnetic Interference) suppression filters for AC power lines eliminate noise entering equipment from commercial power lines or noise generated from electronic equipment.

Common mode chokes, line bypass capacitors, and across the line capacitors are generally used as AC EMI suppression filter devices. In suppressing common mode noise, common mode chokes are the most important devices. Because the characteristics of common mode chokes influence the

performance of the total filter block, MURATA provides two types of common mode chokes (standard type and high frequency type).

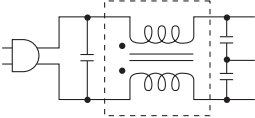
A hybrid choke coil is a high-performance EMI suppression device that can suppress both common mode noise and differential mode noise at the same time. It is effective in AC power supplies with active devices for a higher harmonic countermeasure, which tends to emit relatively higher differential mode noise.

Classification of EMI Suppression Filter for AC Power Lines

Product Name	Appearance	Effective Frequency Range (Hz)						Application
		10k	100k	1M	10M	100M	1G	
Common Mode Choke Coil	Standard Type							 Suppression of general common mode noise
	 PLA10							
Common Mode Choke Coil	High Frequency Type							Suppression of common mode noise which contains high frequency noise above 10MHz
	 PLH10							
Hybrid Choke Coil	 PLY10							Suppression of conduction noise in AC power line with active device for higher harmonic countermeasure. Suppression of AC power line noise which contains both common mode noise and differential mode noise.
Hybrid Choke Coil	 PLY17							For AC power supply, AC adaptor. Set for low-profile equipment.

Outline of EMI Suppression Filter (EMIFIL[®]) for AC Power Lines

Common Mode Choke Coil Standard Winding and Sectional Winding

Standard Winding

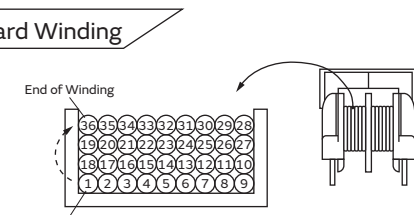

End of Winding

Beginning of Winding

High-frequency noise can pass through the Filter easily because both edges of coils are close, as shown above

Standard Winding

Large inductance is available
 →Highly Efficient in Low Frequency

Sectional Winding

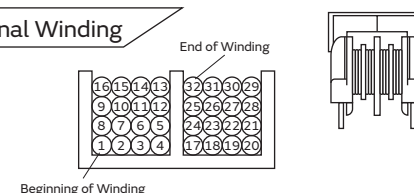

End of Winding

Beginning of Winding

High-frequency noise can hardly pass through the Filter because both edges of coil are not close as shown above

Sectional Winding

Excellent performance in high frequency
 Stray capacity between windings is low

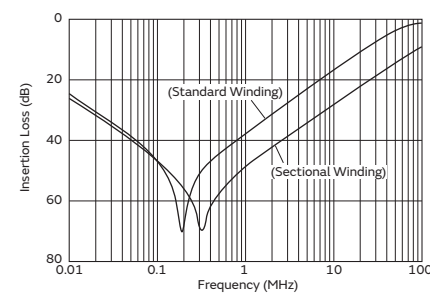

Insertion Loss (dB)

Frequency (MHz)

(Standard Winding)

(Sectional Winding)

Noise Measures for Switching Power Supply

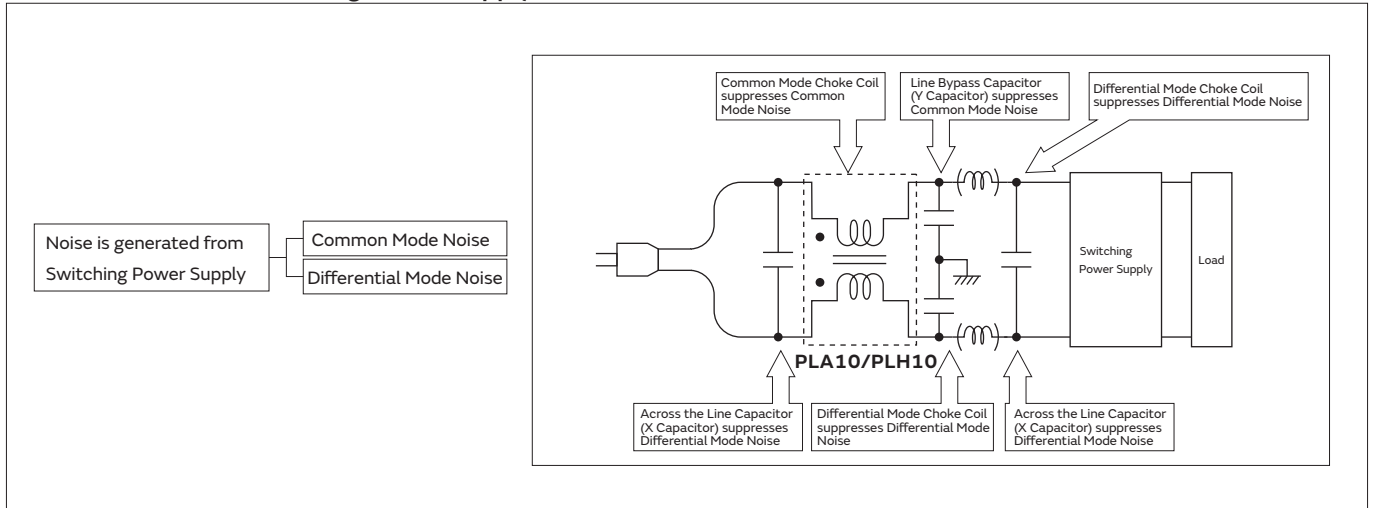

EMI Suppression Filters (EMIFIL®) for AC Power Lines

Common Mode Choke Coil

PLA10 Series

The PLA10 series is a compact size AC common mode choke coil. It can obtain a high inductance value in spite of its compact size.

Features

1. Compact and lightweight
2. Low profile in vertical core layout
3. Both a standard winding type and a sectional winding for higher frequency noise is available.

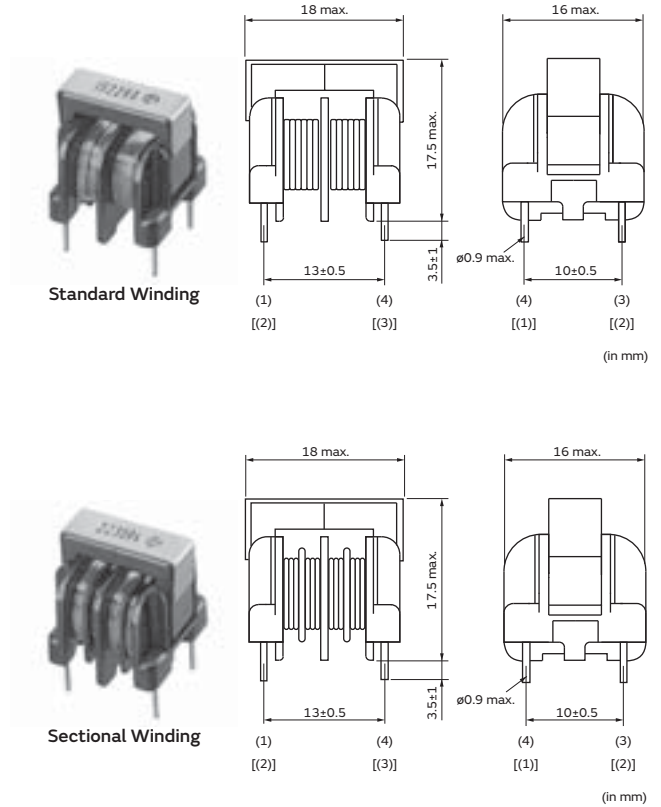

Standard Winding

Part Number	Common Mode Inductance (min.) (mH)	Rated Current (A)	Rated Voltage		Insulation Resistance (min.) (M ohm)
			(VAC)	(VDC)	
PLA10AN1522R0R2B	1.5	2.0	300	500	100
PLA10AN1821R7R2B	1.8	1.7	300	500	100
PLA10AN2221R5R2B	2.2	1.5	300	500	100
PLA10AN3021R3R2B	3.0	1.3	300	500	100
PLA10AN3521R2R2B	3.5	1.2	300	500	100
PLA10AN5521R0R2B	5.5	1.0	300	500	100
PLA10AN7420R8R2B	7.4	0.8	300	500	100
PLA10AN1030R7R2B	10.0	0.7	300	100	100
PLA10AN1230R6R2B	12.0	0.6	300	100	100
PLA10AN2030R5R2B	20.0	0.5	300	100	100
PLA10AN3030R4R2B	30.0	0.4	300	100	100
PLA10AN4330R3R2B	43.0	0.3	300	100	100

Operating Temperature Range: -25°C to 60°C Winding Temperature Rise (at Rated Current): 60°C (max.)

Sectional Winding

Part Number	Common Mode Inductance (min.) (mH)	Rated Current (A)	Rated Voltage		Insulation Resistance (min.) (M ohm)
			(VAC)	(VDC)	
PLA10AN9012R0D2B	0.9	2.0	300	500	100
PLA10AN1321R7D2B	1.3	1.7	300	500	100
PLA10AN1821R5D2B	1.8	1.5	300	500	100
PLA10AN2021R3D2B	2.0	1.3	300	500	100

Continued on the following page. ↗

Continued from the preceding page. ↘

Part Number	Common Mode Inductance (min.) (mH)	Rated Current (A)	Rated Voltage		Insulation Resistance (min.) (M ohm)
			(VAC)	(VDC)	
PLA10AN3621R0D2B	3.6	1.0	300	500	100
PLA10AN7720R7D2B	7.7	0.7	300	100	100
PLA10AN1330R5D2B	13.0	0.5	300	100	100
PLA10AN2230R4D2B	22.0	0.4	300	100	100
PLA10AN3630R3D2B	36.0	0.3	300	100	100

Operating Temperature Range: -25°C to 60°C Winding Temperature Rise (at Rated Current): 60°C (max.)

Equivalent Circuit Diagram

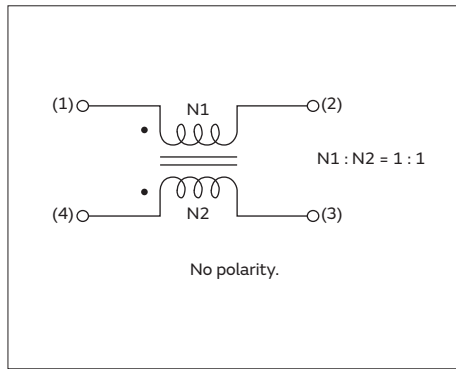

Insertion Loss - Frequency Characteristics

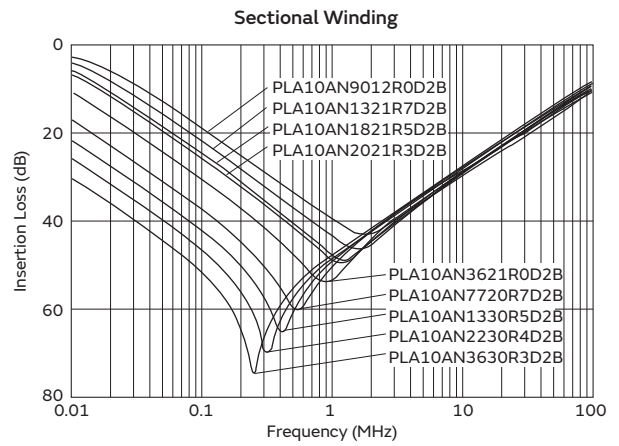
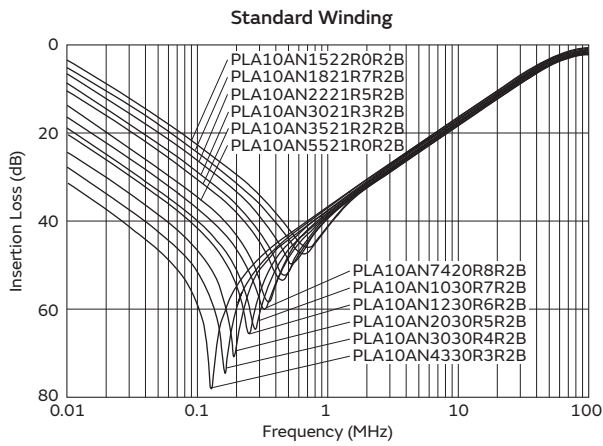

PLA10 Series (Safety Standard Recognized)

Features

1. Compact and lightweight
2. Low profile in vertical core layout
3. Both a standard winding and a sectional winding for higher frequency noise is available.
4. Safety standards: EN60065

Applications

Noise suppression of AC power lines

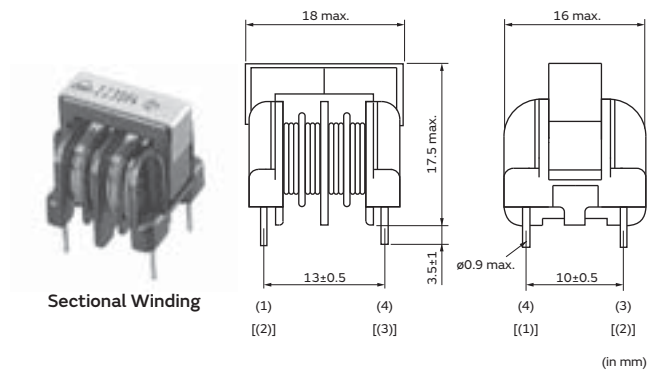
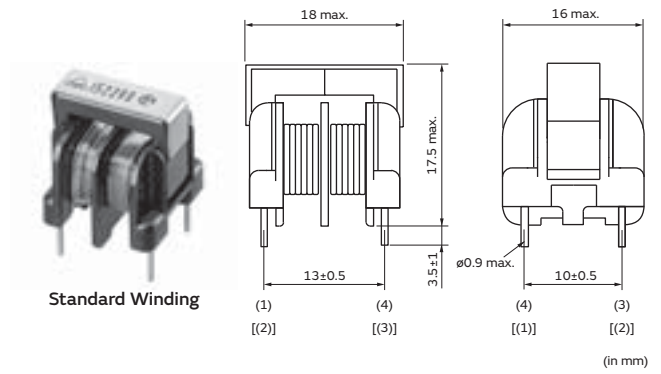

Standard Winding

Part Number	Common Mode Inductance (min.) (mH)	Rated Current (A)	Rated Voltage (VAC)	Insulation Resistance (min.) (M ohm)
PLA10AS1522R0R2B	1.5	2.0	250	100
PLA10AS1821R7R2B	1.8	1.7	250	100
PLA10AS2221R5R2B	2.2	1.5	250	100
PLA10AS3021R3R2B	3.0	1.3	250	100
PLA10AS3521R2R2B	3.5	1.2	250	100
PLA10AS5521R0R2B	5.5	1.0	250	100
PLA10AS7420R8R2B	7.4	0.8	250	100
PLA10AS1030R7R2B	10.0	0.7	250	100
PLA10AS1230R6R2B	12.0	0.6	250	100
PLA10AS2030R5R2B	20.0	0.5	250	100
PLA10AS3030R4R2B	30.0	0.4	250	100
PLA10AS4330R3R2B	43.0	0.3	250	100

Operating Temperature Range: -25°C to 60°C Winding Temperature Rise (at Rated Current): 60°C (max.)

Sectional Winding

Part Number	Common Mode Inductance (min.) (mH)	Rated Current (A)	Rated Voltage (VAC)	Insulation Resistance (min.) (M ohm)
PLA10AS9012R0D2B	0.9	2.0	250	100
PLA10AS1321R7D2B	1.3	1.7	250	100
PLA10AS1821R5D2B	1.8	1.5	250	100
PLA10AS2021R3D2B	2.0	1.3	250	100
PLA10AS3621R0D2B	3.6	1.0	250	100
PLA10AS7720R7D2B	7.7	0.7	250	100
PLA10AS1330R5D2B	13.0	0.5	250	100
PLA10AS2230R4D2B	22.0	0.4	250	100
PLA10AS3630R3D2B	36.0	0.3	250	100

Operating Temperature Range: -25°C to 60°C Winding Temperature Rise (at Rated Current): 60°C (max.)

Equivalent Circuit Diagram

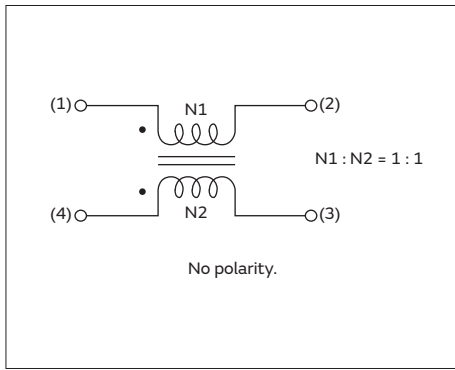

Insertion Loss - Frequency Characteristics

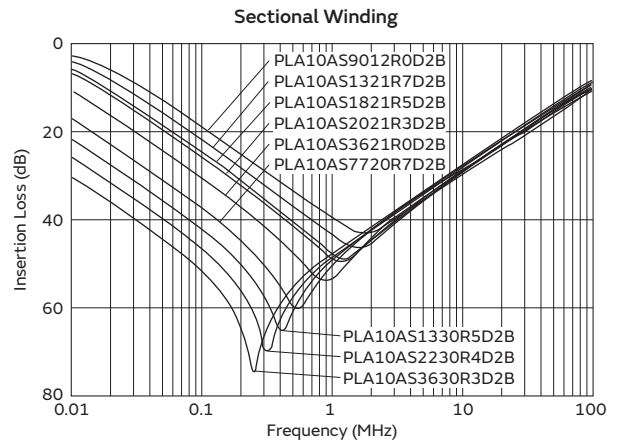
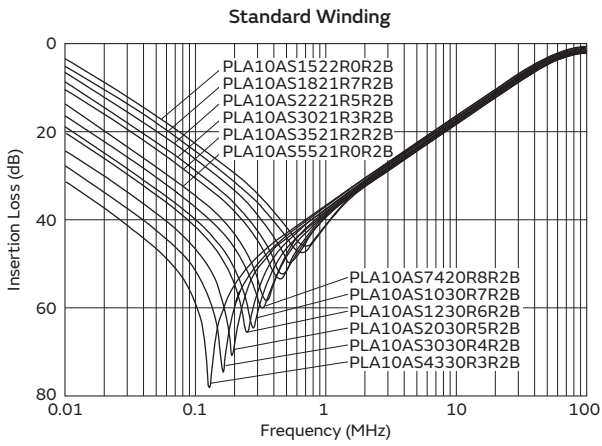

PLA10 Series High Inductance

The PLA10 series is a compact size AC common mode choke coil. It can obtain a high inductance value in spite of its compact size.

Features

1. Compact and lightweight
2. Low profile in vertical core layout
3. This is high inductance choke coil by high permeability ferrite core.

The inductance of new (high inductance) series is increased 100% compared with our existing products.

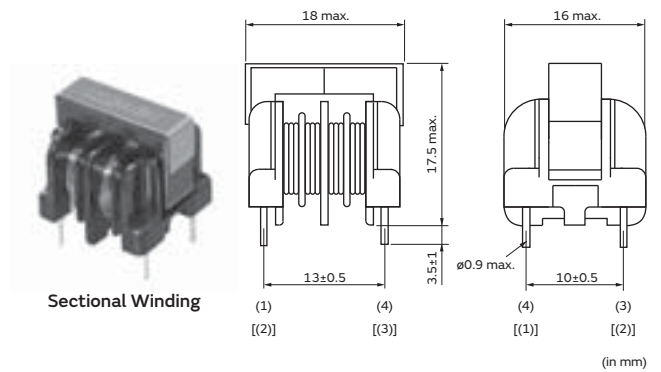
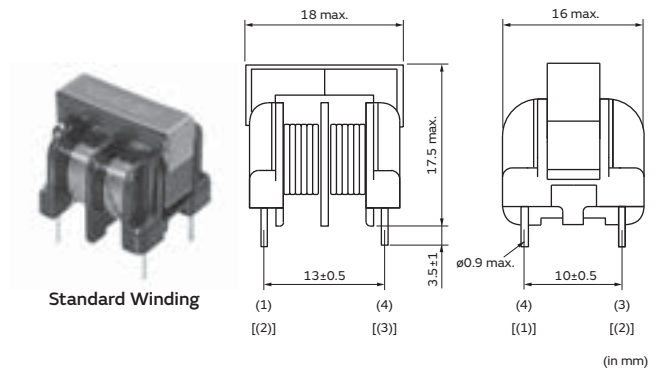

Standard Winding

Part Number	Common Mode Inductance (min.) (mH)	Rated Current (A)	Rated Voltage		Insulation Resistance (min.) (M ohm)
			(VAC)	(VDC)	
PLA10AH2222R2R2B	2.2	2.2	300	500	100
PLA10AH3321R8R2B	3.3	1.8	300	500	100
PLA10AH5321R4R2B	5.3	1.4	300	500	100
PLA10AH1031R0R2B	10.0	1.0	300	500	100
PLA10AH1330R8R2B	13.0	0.8	300	100	100
PLA10AH1830R7R2B	18.0	0.7	300	100	100
PLA10AH2830R6R2B	28.0	0.6	300	100	100
PLA10AH4130R5R2B	41.0	0.5	300	100	100

Operating Temperature Range: -25°C to 55°C Winding Temperature Rise (at Rated Current): 60°C (max.)

Sectional Winding

Part Number	Common Mode Inductance (min.) (mH)	Rated Current (A)	Rated Voltage		Insulation Resistance (min.) (M ohm)
			(VAC)	(VDC)	
PLA10AH1222R4D2B	1.2	2.4	300	500	100
PLA10AH2921R7D2B	2.9	1.7	300	500	100
PLA10AH3821R4D2B	3.8	1.4	300	500	100
PLA10AH5921R1D2B	5.9	1.1	300	500	100
PLA10AH7121R0D2B	7.1	1.0	300	500	100
PLA10AH1230R8D2B	12.0	0.8	300	100	100
PLA10AH1530R7D2B	15.0	0.7	300	100	100
PLA10AH2030R6D2B	20.0	0.6	300	100	100
PLA10AH2930R5D2B	29.0	0.5	300	100	100

Operating Temperature Range: -25°C to 55°C Winding Temperature Rise (at Rated Current): 60°C (max.)

Equivalent Circuit Diagram

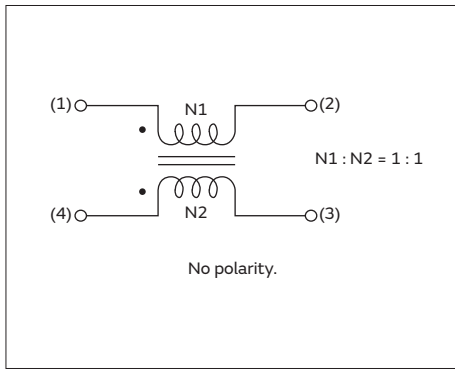

Insertion Loss - Frequency Characteristics

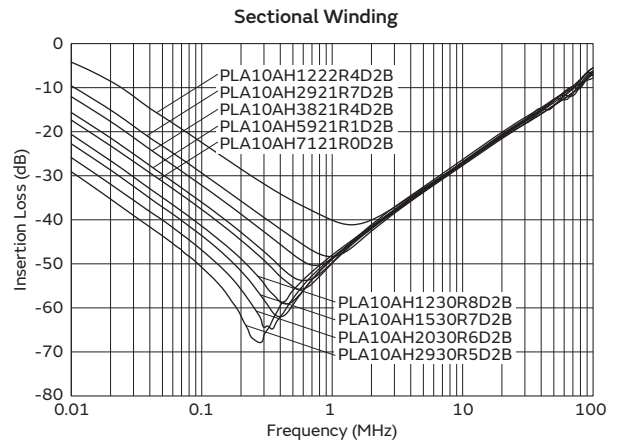
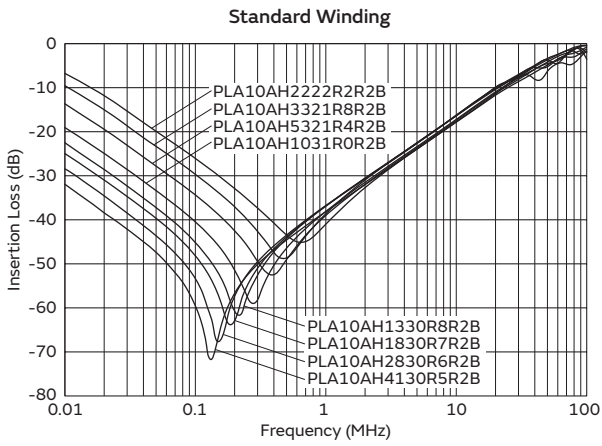

PLA10 Series High Inductance (Safety Standard Recognized)

The PLA10 series is a compact size AC common mode choke coil. It can obtain a high inductance value in spite of its compact size.

Features

1. Compact and lightweight
2. Low profile in vertical core layout
3. This is high inductance choke coil by high permeability ferrite core.
 The inductance of new (high inductance) series is increased 100% compared with our existing products.
4. Safety standards: EN60065

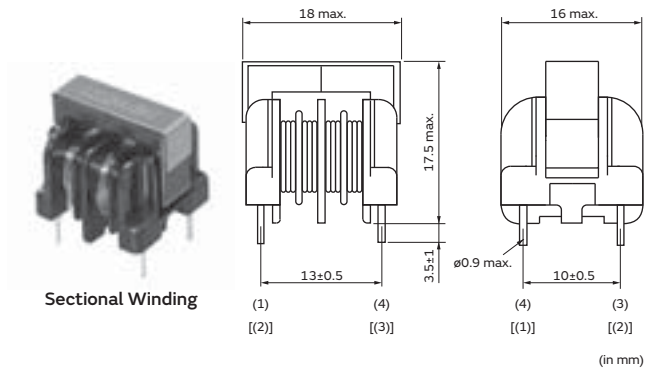
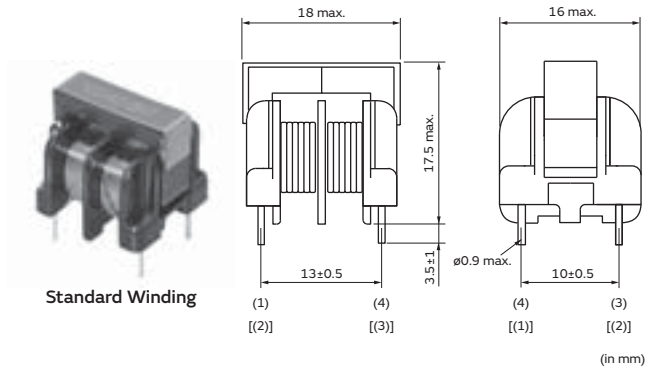

Standard Winding

Part Number	Common Mode Inductance (min.) (mH)	Rated Current (A)	Rated Voltage (VAC)	Insulation Resistance (min.) (M ohm)
PLA10AV2222R2R2B	2.2	2.2	250	100
PLA10AV3321R8R2B	3.3	1.8	250	100
PLA10AV5321R4R2B	5.3	1.4	250	100
PLA10AV1031R0R2B	10.0	1.0	250	100
PLA10AV1330R8R2B	13.0	0.8	250	100
PLA10AV1830R7R2B	18.0	0.7	250	100
PLA10AV2830R6R2B	28.0	0.6	250	100
PLA10AV4130R5R2B	41.0	0.5	250	100

Operating Temperature Range: -25°C to 55°C Winding Temperature Rise (at Rated Current): 60°C (max.)

Sectional Winding

Part Number	Common Mode Inductance (min.) (mH)	Rated Current (A)	Rated Voltage (VAC)	Insulation Resistance (min.) (M ohm)
PLA10AV1222R4D2B	1.2	2.4	250	100
PLA10AV2921R7D2B	2.9	1.7	250	100
PLA10AV3821R4D2B	3.8	1.4	250	100
PLA10AV5921R1D2B	5.9	1.1	250	100
PLA10AV7121R0D2B	7.1	1.0	250	100
PLA10AV1230R8D2B	12.0	0.8	250	100
PLA10AV1530R7D2B	15.0	0.7	250	100
PLA10AV2030R6D2B	20.0	0.6	250	100
PLA10AV2930R5D2B	29.0	0.5	250	100

Operating Temperature Range: -25°C to 55°C Winding Temperature Rise (at Rated Current): 60°C (max.)

1

Equivalent Circuit Diagram

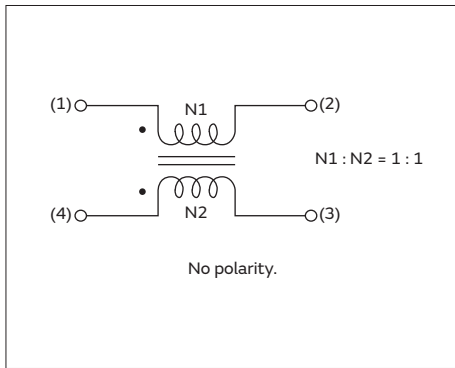

Insertion Loss - Frequency Characteristics

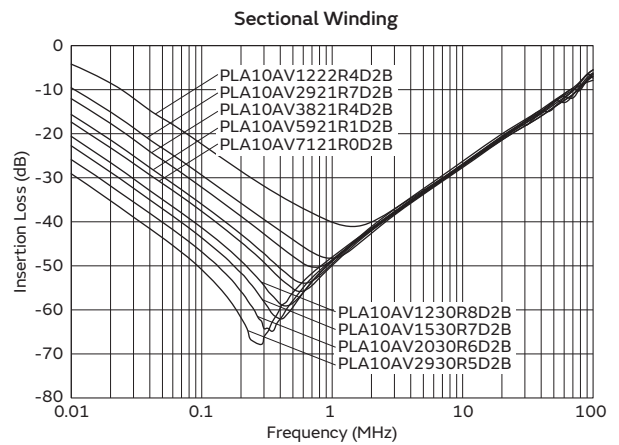
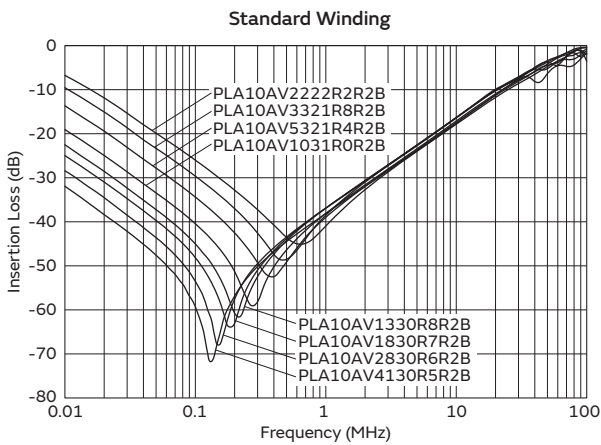

12

PLH10 Series

The PLH10 series is a common mode choke coil for high frequency use. The same dimensions as the PLA10 series enables flexible design.

Features

1. High performance in high frequency range
2. Compact and lightweight
3. Low profile in vertical core layout

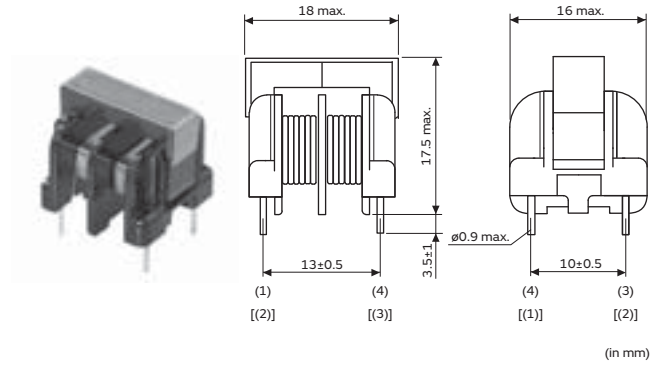

Part Number	Common Mode Inductance (min.) (μ H)	Rated Current (A)	Rated Voltage		Insulation Resistance (min.) (M ohm)
			(VAC)	(VDC)	
PLH10AN7003R6P2B	70	3.6	300	500	100
PLH10AN1112R6P2B	110	2.6	300	500	100
PLH10AN1612R1P2B	160	2.1	300	500	100
PLH10AN2211R5P2B	220	1.5	300	100	100
PLH10AN2911R2P2B	290	1.2	300	100	100
PLH10AN3711R0P2B	370	1.0	300	100	100

Operating Temperature Range: -25°C to 60°C Winding Temperature Rise (at Rated Current): 60°C (max.)

Equivalent Circuit Diagram

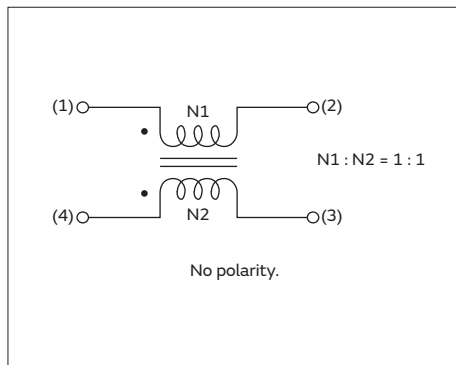

Insertion Loss - Frequency Characteristics

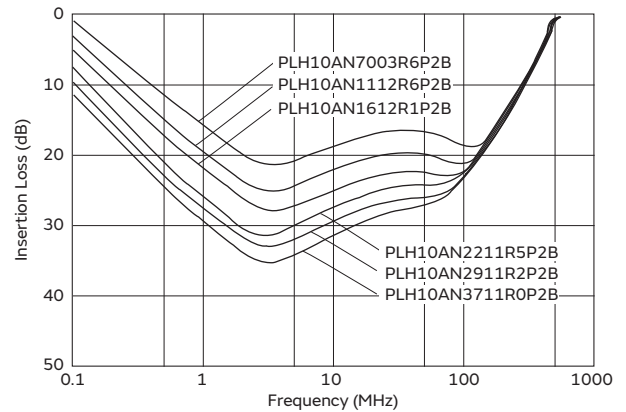

PLH10 Series (Safety Standard Recognized)

Features

1. High performance in high frequency range
2. Compact and lightweight
3. Low profile in vertical core layout
4. Safety standards: EN60065

Applications

Suppressing radiation noise in switching power supply and inverter (AC-DC converter)

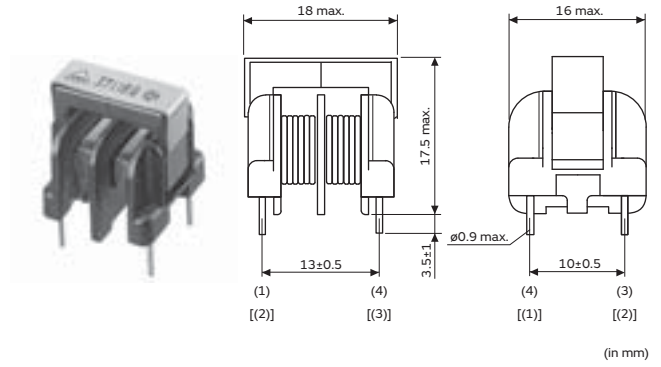

Part Number	Common Mode Inductance (min.) (μH)	Rated Current (A)	Rated Voltage (VAC)	Insulation Resistance (min.) (M ohm)
PLH10AS7003R6P2B	70	3.6	250	100
PLH10AS1112R6P2B	110	2.6	250	100
PLH10AS1612R1P2B	160	2.1	250	100
PLH10AS2211R5P2B	220	1.5	250	100
PLH10AS2911R2P2B	290	1.2	250	100
PLH10AS3711R0P2B	370	1.0	250	100

Operating Temperature Range: -25°C to 60°C Winding Temperature Rise (at Rated Current): 60°C (max.)

Equivalent Circuit Diagram

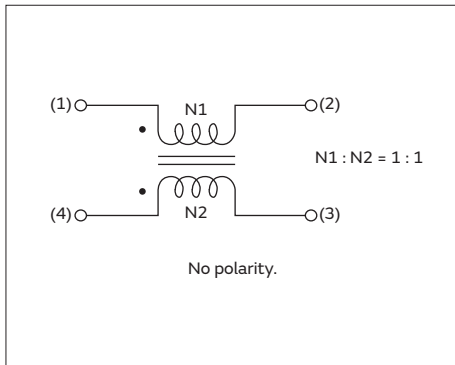

Insertion Loss - Frequency Characteristics

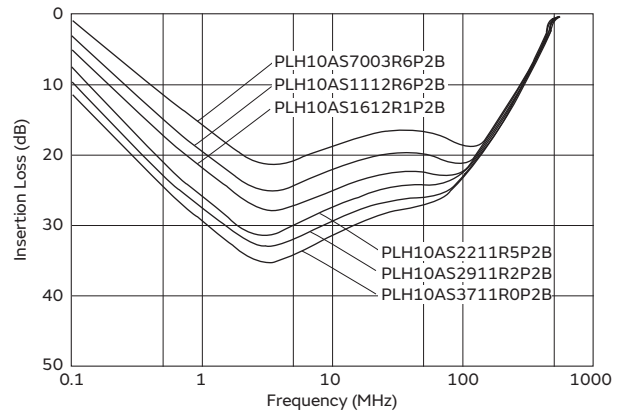

EMI Suppression Filters (EMIFIL®) for AC Power Lines

Hybrid Choke Coil

PLY10 Series

The PLY10 is a compact and high-performance hybrid choke coil that can handle differential mode noise caused by the harmonics currents regulation circuit as well as common mode noise. It can handle noise problems much more compactly than a combination of a conventional common mode choke coil and a differential mode choke coil.

Features

1. PLY10 has both functions of a common mode choke coil and a differential mode choke coil in its compact body.
2. Low profile in vertical core layout
3. PLY10 has the same pin layout as a general common mode choke coil which enables it to replace conventional components.
4. Both a standard winding and a sectional winding for higher frequency noise is available.

EMI Problem for harmonics currents regulation

There are some methods that meet harmonics currents regulations (IEC1000-3, EN60555-2) such as an active filter and one converter. However, they cause new EMI problems of differential mode noise because they use active components. For that reason, additional filter components to meet differential mode noise must be applied.



Standard Winding

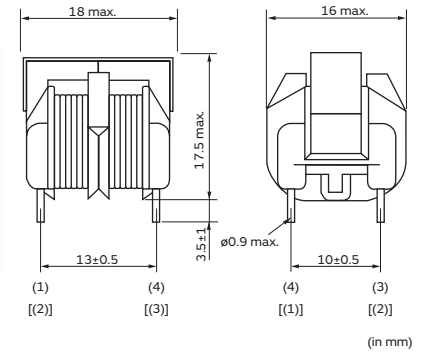

Sectional Winding

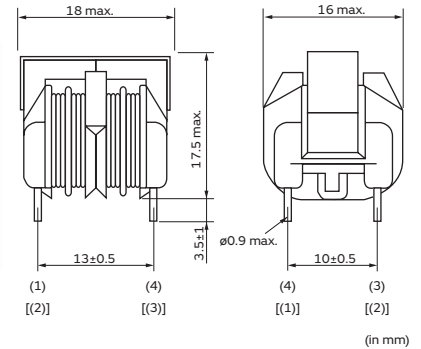

Standard Winding

Part Number	Common Mode Inductance (min.) (mH)	Normal Mode Inductance (min.) (µH)	Rated Current (A)	Rated Voltage	
				(VAC)	(VDC)
PLY10AN9012R0R2B	0.9	65	2.0	300	500
PLY10AN1121R8R2B	1.1	90	1.8	300	500
PLY10AN1521R6R2B	1.5	110	1.6	300	500
PLY10AN2121R4R2B	2.1	150	1.4	300	500
PLY10AN2821R2R2B	2.8	190	1.2	300	500
PLY10AN4321R0R2B	4.3	300	1.0	300	500
PLY10AN6220R8R2B	6.2	400	0.8	300	50
PLY10AN8720R7R2B	8.7	530	0.7	300	50
PLY10AN9920R6R2B	9.9	690	0.6	300	50
PLY10AN1430R5R2B	14.0	1000	0.5	300	50

Operating Temperature Range: -25°C to 60°C Winding Temperature Rise (at Rated Current): 60°C (max.)

Sectional Winding

Part Number	Common Mode Inductance (min.) (mH)	Normal Mode Inductance (min.) (µH)	Rated Current (A)	Rated Voltage	
				(VAC)	(VDC)
PLY10AN7012R0D2B	0.7	50	2.0	300	500
PLY10AN1121R7D2B	1.1	65	1.7	300	500

Continued on the following page. ↗

Continued from the preceding page. ↘

Part Number	Common Mode Inductance (min.) (mH)	Normal Mode Inductance (min.) (μH)	Rated Current (A)	Rated Voltage	
				(VAC)	(VDC)
PLY10AN1421R4D2B	1.4	110	1.4	300	500
PLY10AN2321R2D2B	2.3	160	1.2	300	500
PLY10AN3521R0D2B	3.5	240	1.0	300	500
PLY10AN4420R8D2B	4.4	320	0.8	300	50
PLY10AN8720R7D2B	8.7	500	0.7	300	50
PLY10AN9720R6D2B	9.7	670	0.6	300	50
PLY10AN1130R5D2B	11.0	840	0.5	300	50

Operating Temperature Range: -25°C to 60°C Winding Temperature Rise (at Rated Current): 60°C (max.)

Equivalent Circuit Diagram

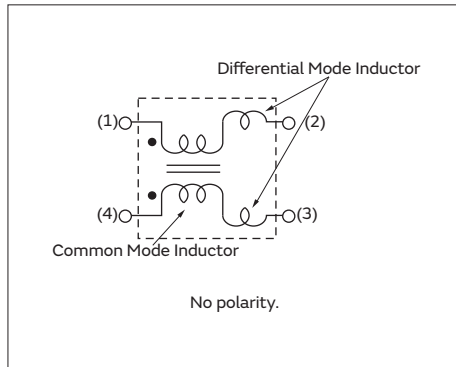

Common Mode Insertion Loss - Frequency Characteristics

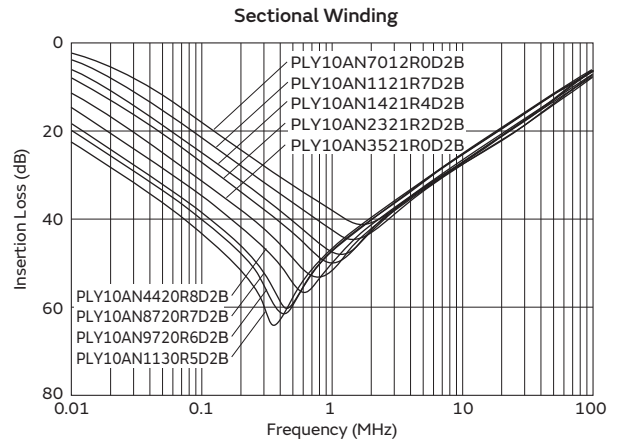
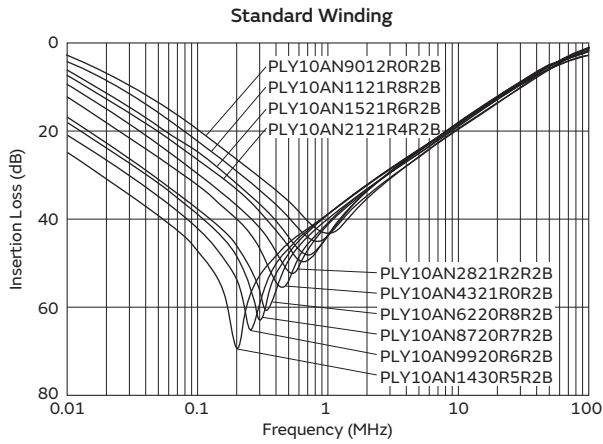

Differential Mode Insertion Loss - Frequency Characteristics

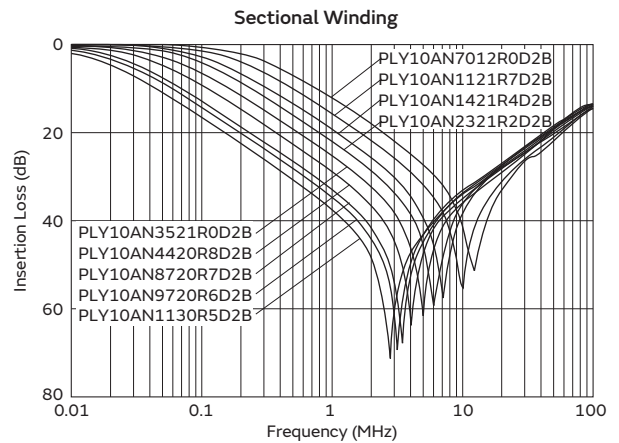
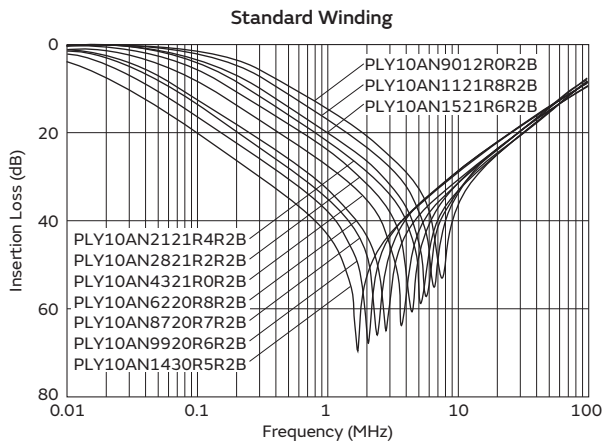

PLY10 Series (Safety Standard Recognized)

The PLY10 is a compact and high-performance hybrid choke coil that can handle differential mode noise caused by the harmonics currents regulation circuit as well as common mode noise. It can handle noise problems much more compactly than a combination of a conventional common mode choke coil and a differential mode choke coil.

Features

1. PLY10 has both functions of a common mode choke coil and a differential mode choke coil in its compact body.
2. Low profile in vertical core layout
3. PLY10 has the same pin layout as a general common mode choke coil which enables it to replace conventional components.
4. Safety standards: EN60065

EMI Problem for harmonics currents regulation

There are some methods that meet harmonics currents regulations (IEC1000-3, EN60555-2) such as an active filter and one converter. However, they cause new EMI problems of differential mode noise because they use active components. For that reason, additional filter components to meet differential mode noise must be applied.

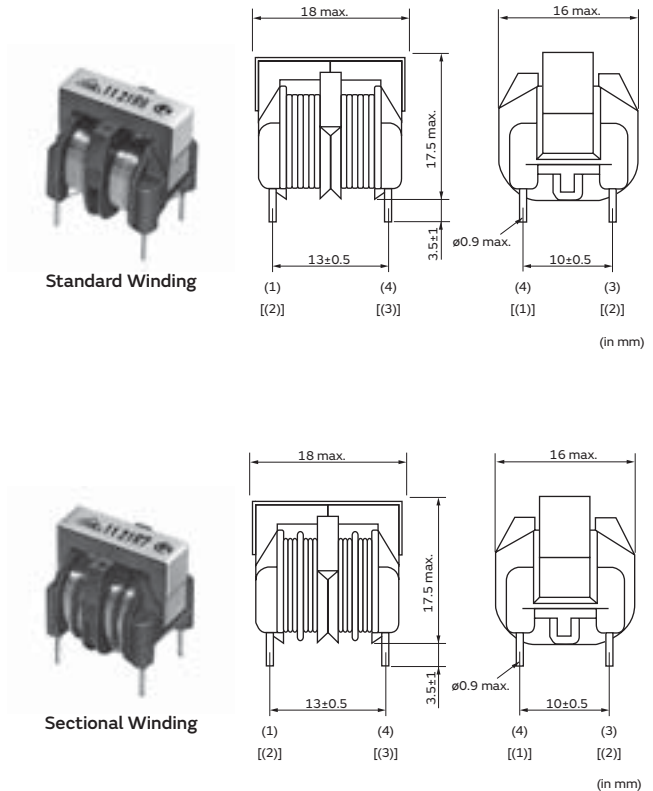

Standard Winding

Part Number	Common Mode Inductance (min.) (mH)	Normal Mode Inductance (min.) (μH)	Rated Current (A)	Rated Voltage (VAC)
PLY10AS9012R0R2B	0.9	65	2.0	300
PLY10AS1121R8R2B	1.1	90	1.8	300
PLY10AS1521R6R2B	1.5	110	1.6	300
PLY10AS2121R4R2B	2.1	150	1.4	300
PLY10AS2821R2R2B	2.8	190	1.2	300
PLY10AS4321R0R2B	4.3	300	1.0	300
PLY10AS6220R8R2B	6.2	400	0.8	300
PLY10AS8720R7R2B	8.7	530	0.7	300
PLY10AS9920R6R2B	9.9	690	0.6	300
PLY10AS1430R5R2B	14.0	1000	0.5	300

Operating Temperature Range: -25°C to 60°C Winding Temperature Rise (at Rated Current): 60°C (max.)

Sectional Winding

Part Number	Common Mode Inductance (min.) (mH)	Normal Mode Inductance (min.) (μH)	Rated Current (A)	Rated Voltage (VAC)
PLY10AS7012R0D2B	0.7	50	2.0	300
PLY10AS1121R7D2B	1.1	65	1.7	300
PLY10AS1421R4D2B	1.4	110	1.4	300
PLY10AS2321R2D2B	2.3	160	1.2	300
PLY10AS3521R0D2B	3.5	240	1.0	300
PLY10AS4420R8D2B	4.4	320	0.8	300
PLY10AS8720R7D2B	8.7	500	0.7	300
PLY10AS9720R6D2B	9.7	670	0.6	300
PLY10AS1130R5D2B	11.0	840	0.5	300

Operating Temperature Range: -25°C to 60°C Winding Temperature Rise (at Rated Current): 60°C (max.)

Equivalent Circuit Diagram

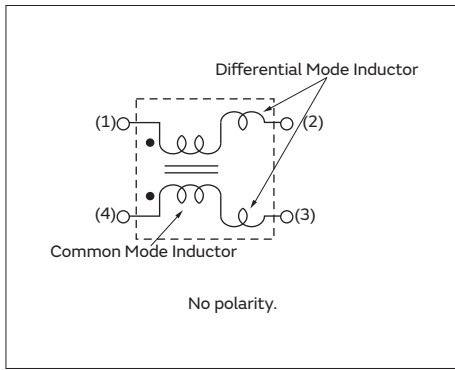

Common Mode Insertion Loss - Frequency Characteristics

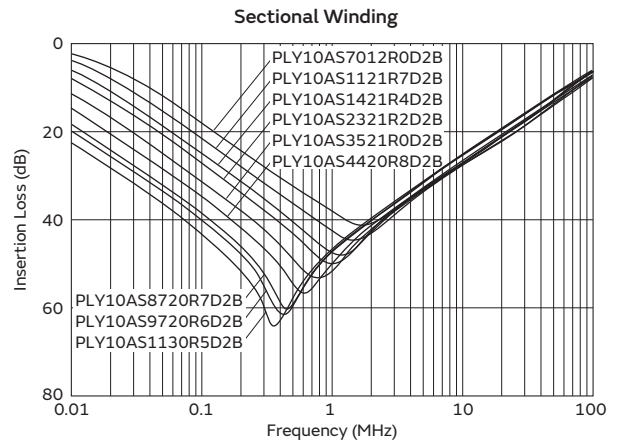
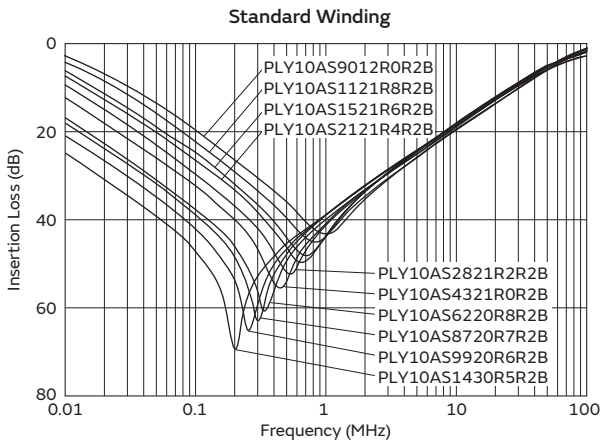

Differential Mode Insertion Loss - Frequency Characteristics

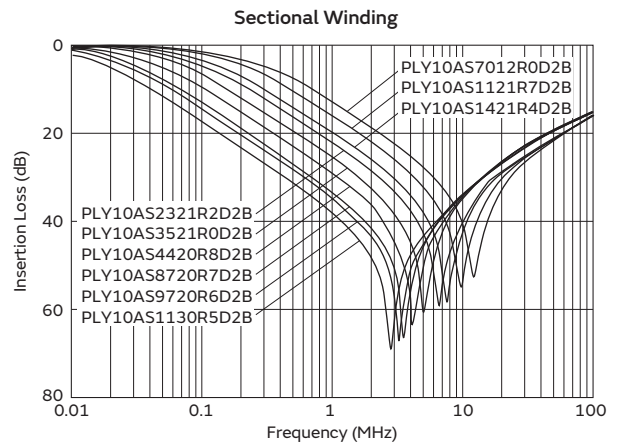
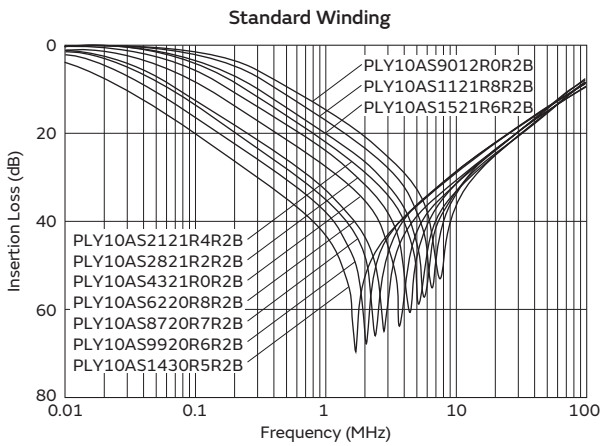

PLY10 Series High Inductance

The PLY10 is a compact and high-performance hybrid choke coil that can handle differential mode noise caused by the harmonics currents regulation circuit as well as common mode noise. It can handle noise problems much more compactly than a combination of a conventional common mode choke coil and a differential mode choke coil.

Features

1. PLY10 has both functions of a common mode choke coil and a differential mode choke coil in its compact body.
2. Low profile in vertical core layout.
3. PLY10 has the same pin layout as a general common mode choke coil which enables it to replace conventional components.
4. This is high inductance choke coil by high permeability ferrite core.
 The inductance of new (high inductance) series is increased 100% compared with our existing products.

EMI Problem for harmonics currents regulation

There are some methods that meet harmonics currents regulations (IEC1000-3, EN60555-2) such as an active filter and one converter. However, they cause new EMI problems of differential mode noise because they use active components. For that reason, additional filter components to meet differential mode noise must be applied.



Standard Winding

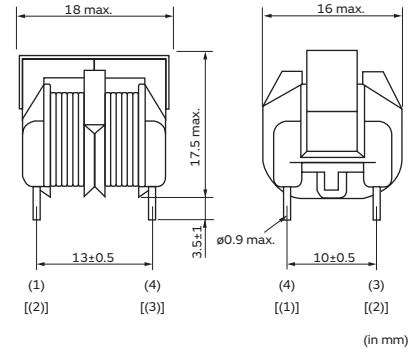

Sectional Winding

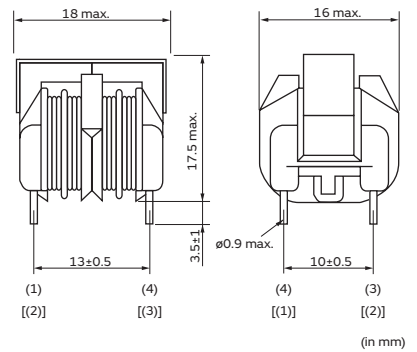

Standard Winding

Part Number	Common Mode Inductance (min.) (mH)	Normal Mode Inductance (min.) (µH)	Rated Current (A)	Rated Voltage	
				(VAC)	(VDC)
PLY10AH2222R1R2B	2.2	90	2.1	300	500
PLY10AH3321R7R2B	3.3	130	1.7	300	500
PLY10AH5121R3R2B	5.1	210	1.3	300	500
PLY10AH1031R0R2B	10.0	390	1.0	300	500
PLY10AH1430R8R2B	14.0	590	0.8	300	50
PLY10AH2030R7R2B	20.0	820	0.7	300	50
PLY10AH2530R6R2B	25.0	1000	0.6	300	50
PLY10AH3730R5R2B	37.0	1500	0.5	300	50

Operating Temperature Range: -25°C to 55°C Winding Temperature Rise (at Rated Current): 60°C (max.)

Sectional Winding

Part Number	Common Mode Inductance (min.) (mH)	Normal Mode Inductance (min.) (µH)	Rated Current (A)	Rated Voltage	
				(VAC)	(VDC)
PLY10AH1422R3D2B	1.4	50	2.3	300	500
PLY10AH2121R8D2B	2.1	80	1.8	300	500
PLY10AH6721R0D2B	6.7	260	1.0	300	500
PLY10AH1130R8D2B	11.0	460	0.8	300	50
PLY10AH1630R7D2B	16.0	650	0.7	300	50
PLY10AH1930R6D2B	19.0	760	0.6	300	50
PLY10AH2630R5D2B	26.0	1000	0.5	300	50

Operating Temperature Range: -25°C to 55°C Winding Temperature Rise (at Rated Current): 60°C (max.)

Equivalent Circuit Diagram

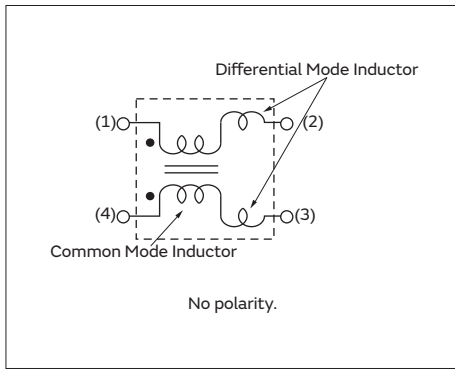

Common Mode Insertion Loss - Frequency Characteristics

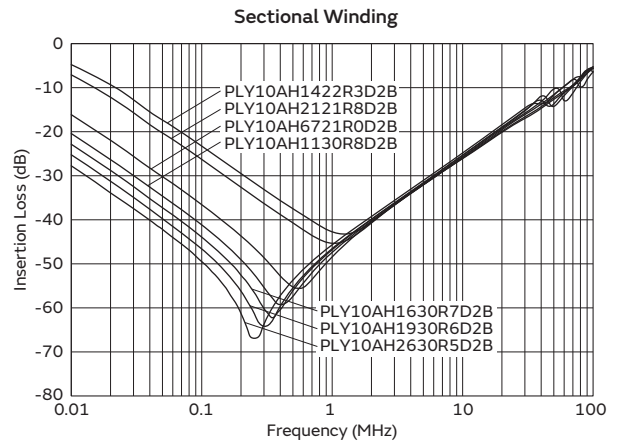
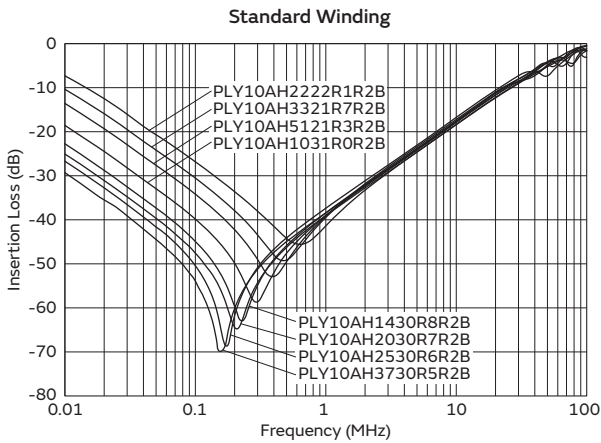

Differential Mode Insertion Loss - Frequency Characteristics

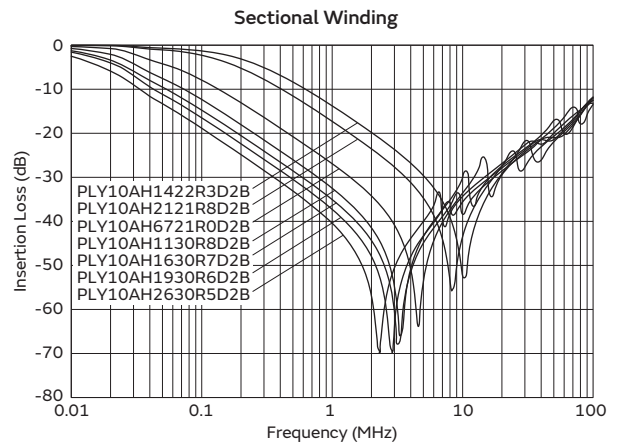
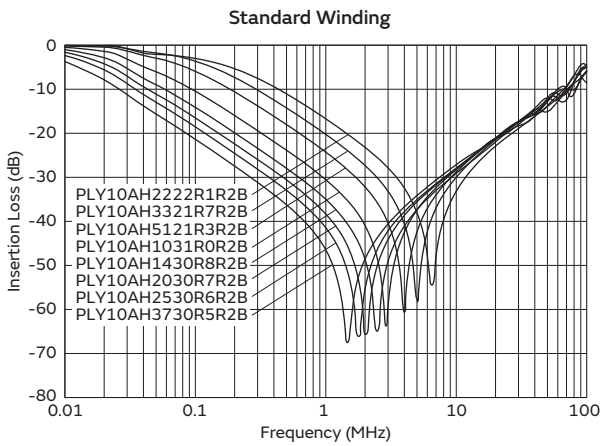

PLY10 Series High Inductance (Safety Standard Recognized)

The PLY10 is a compact and high-performance hybrid choke coil that can handle differential mode noise caused by the harmonics currents regulation circuit as well as common mode noise. It can handle noise problems much more compactly than a combination of a conventional common mode choke coil and a differential mode choke coil.

Features

1. PLY10 has both functions of a common mode choke coil and a differential mode choke coil in its compact body.
2. Low profile in vertical core layout.
3. PLY10 has the same pin layout as a general common mode choke coil which enables it to replace conventional components.
4. This is high inductance choke coil by high permeability ferrite core.
 The inductance of new (high inductance) series is increased 100% compared with our existing products.
5. Safety standards: EN60065

EMI Problem for harmonics currents regulation

There are some methods that meet harmonics currents regulations (IEC1000-3, EN60555-2) such as an active filter and one converter. However, they cause new EMI problems of differential mode noise because they use active components. For that reason, additional filter components to meet differential mode noise must be applied.



Standard Winding

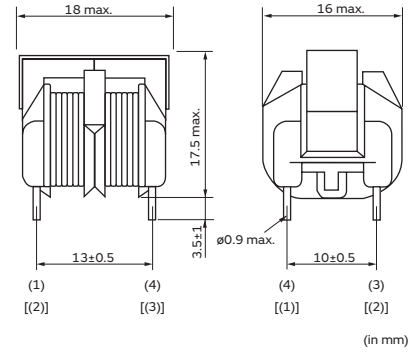

Sectional Winding

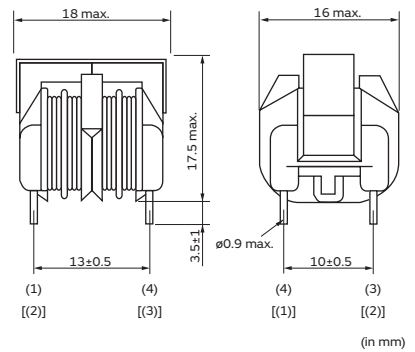

Standard Winding

Part Number	Common Mode Inductance (min.) (mH)	Normal Mode Inductance (min.) (μH)	Rated Current (A)	Rated Voltage (VAC)
PLY10AV2222R1R2B	2.2	90	2.1	300
PLY10AV3321R7R2B	3.3	130	1.7	300
PLY10AV5121R3R2B	5.1	210	1.3	300
PLY10AV1031R0R2B	10.0	390	1.0	300
PLY10AV1430R8R2B	14.0	590	0.8	300
PLY10AV2030R7R2B	20.0	820	0.7	300
PLY10AV2530R6R2B	25.0	1000	0.6	300
PLY10AV3730R5R2B	37.0	1500	0.5	300

Operating Temperature Range: -25°C to 55°C Winding Temperature Rise (at Rated Current): 60°C (max.)

Sectional Winding

Part Number	Common Mode Inductance (min.) (mH)	Normal Mode Inductance (min.) (μH)	Rated Current (A)	Rated Voltage (VAC)
PLY10AV1422R3D2B	1.4	50	2.3	300
PLY10AV2121R8D2B	2.1	80	1.8	300
PLY10AV6721R0D2B	6.7	260	1.0	300
PLY10AV1130R8D2B	11.0	460	0.8	300
PLY10AV1630R7D2B	16.0	650	0.7	300
PLY10AV1930R6D2B	19.0	760	0.6	300
PLY10AV2630R5D2B	26.0	1000	0.5	300

Operating Temperature Range: -25°C to 55°C Winding Temperature Rise (at Rated Current): 60°C (max.)

Equivalent Circuit Diagram

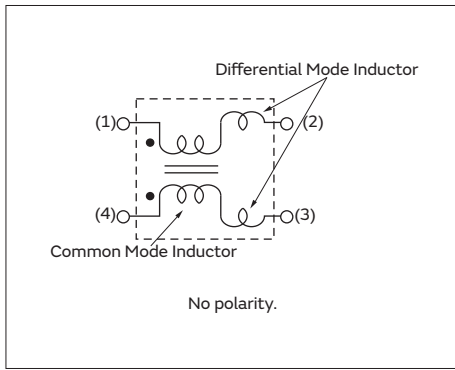

2

Common Mode Insertion Loss - Frequency Characteristics

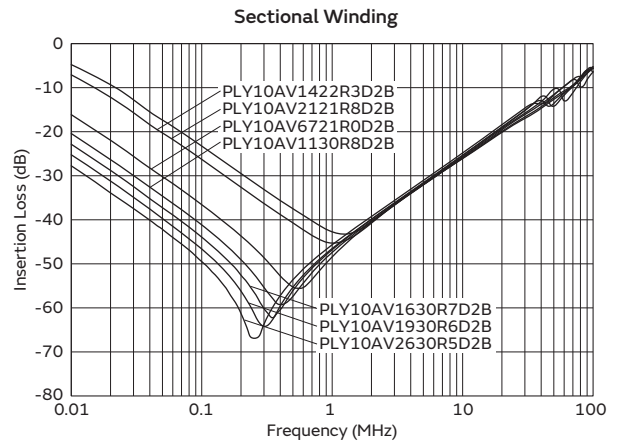
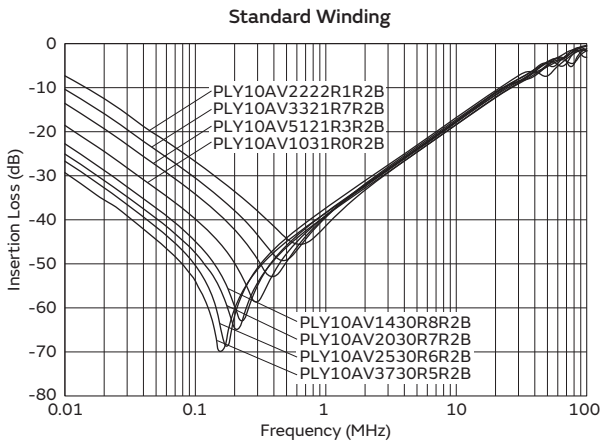

Differential Mode Insertion Loss - Frequency Characteristics

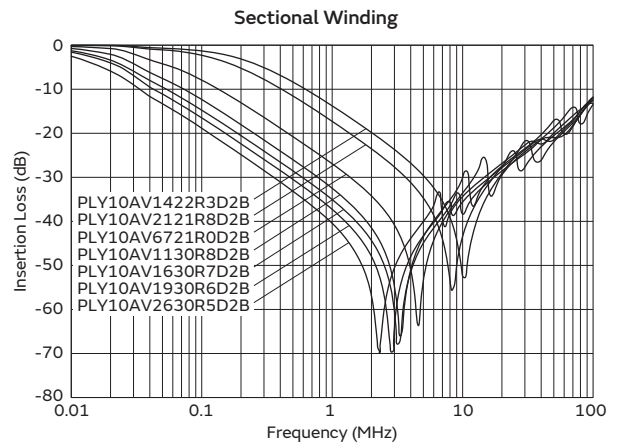
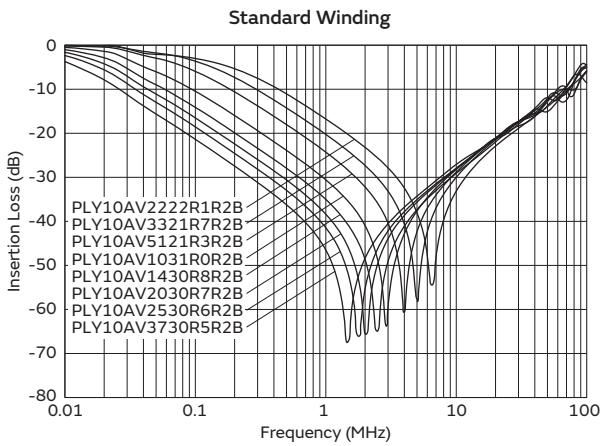

PLY17 Series

Features

1. Integration of choke coil function to suppress differential mode/Low and High Frequency common mode noise.
2. Low Profile (H=<13mm)

Applications

1. For AC power supply, AC adapter
2. Low-profile equipment such as lighting equipment, FPD, Digital Amplifier



A/B Type

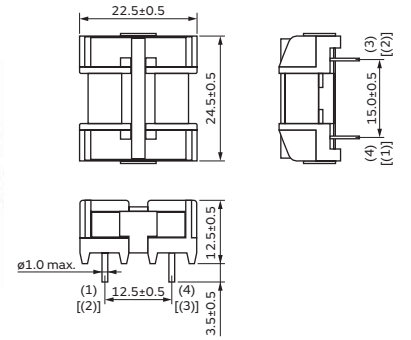

(in mm)

A Type

Part Number	Common Mode Inductance (min.) (mH)	Normal Mode Inductance (min.) (μH)	Rated Current (A)	Rated Voltage (VAC)
PLY17BN4912R4A2B	0.49	18	2.4	300
PLY17BN9612R0A2B	0.96	36	2.0	300
PLY17BN1023R0A2B	1.0	36	3.0	300
PLY17BN1121R8A2B	1.1	44	1.8	300
PLY17BN1721R5A2B	1.7	67	1.5	300
PLY17BN2921R2A2B	2.9	110	1.2	300
PLY17BN3721R0A2B	3.7	140	1.0	300
PLY17BN5620R8A2B	5.6	210	0.8	300
PLY17BN7820R7A2B	7.8	290	0.7	300
PLY17BN9320R6A2B	9.3	350	0.6	300

Operating Temperature Range: -25°C to 60°C Winding Temperature Rise (at Rated Current): 60°C (max.)

B Type

Part Number	Common Mode Inductance (min.) (mH)	Normal Mode Inductance (min.) (μH)	Rated Current (A)	Rated Voltage (VAC)
PLY17BN4912R4B2B	0.49	24	2.4	300
PLY17BN9612R0B2B	0.96	47	2.0	300
PLY17BN1023R0B2B	1.0	47	3.0	300
PLY17BN1121R8B2B	1.1	58	1.8	300
PLY17BN1721R5B2B	1.7	88	1.5	300
PLY17BN2921R2B2B	2.9	140	1.2	300
PLY17BN3721R0B2B	3.7	180	1.0	300
PLY17BN5620R8B2B	5.6	280	0.8	300
PLY17BN7820R7B2B	7.8	390	0.7	300
PLY17BN9320R6B2B	9.3	460	0.6	300

Operating Temperature Range: -25°C to 60°C Winding Temperature Rise (at Rated Current): 60°C (max.)

Equivalent Circuit Diagram

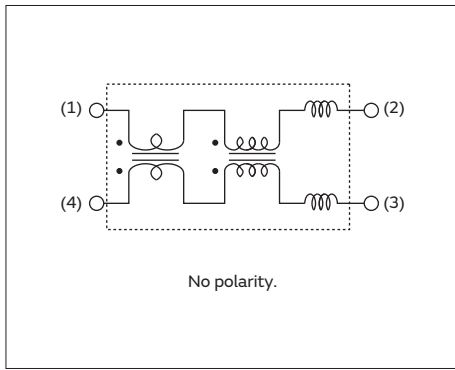

2

Common Mode Insertion Loss - Frequency Characteristics

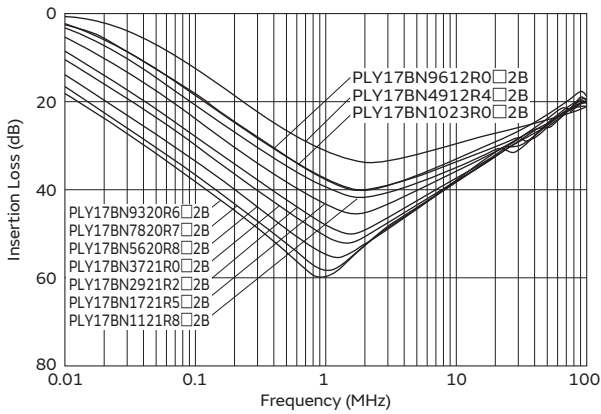

Differential Mode Insertion Loss - Frequency Characteristics

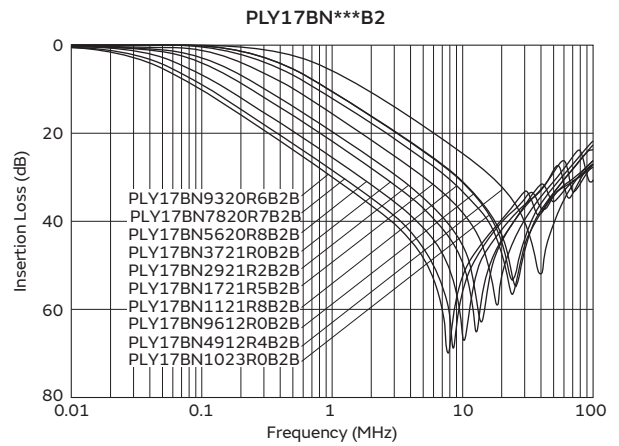
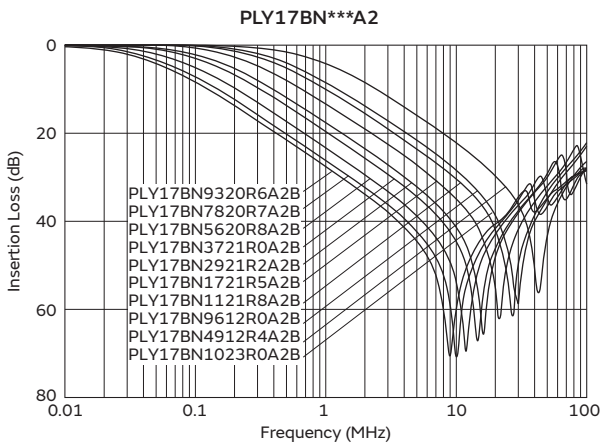

PLY17 Series (Safety Standard Recognized)

Features

1. Integration of choke coil function to suppress differential mode/Low and High Frequency common mode noise.
2. Low Profile (H=<13mm)
3. Safety standards: EN60065

Applications

1. For AC power supply, AC adapter
2. Low-profile equipment such as lighting equipment, FPD, Digital Amplifier

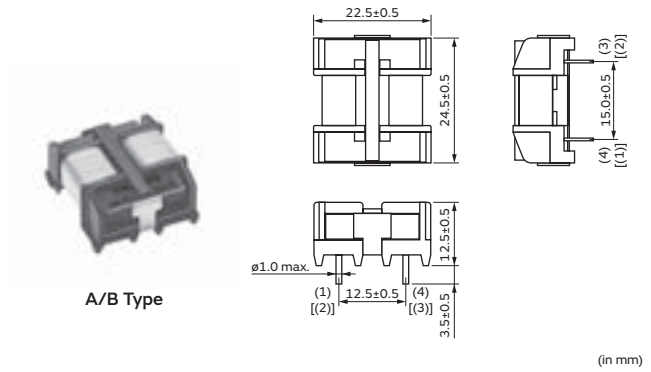

A Type

Part Number	Common Mode Inductance (min.) (mH)	Normal Mode Inductance (min.) (μH)	Rated Current (A)	Rated Voltage (VAC)
PLY17BS4912R4A2B	0.49	18	2.4	250
PLY17BS9612R0A2B	0.96	36	2.0	250
PLY17BS1023R0A2B	1.0	36	3.0	250
PLY17BS1121R8A2B	1.1	44	1.8	250
PLY17BS1721R5A2B	1.7	67	1.5	250
PLY17BS2921R2A2B	2.9	110	1.2	250
PLY17BS3721R0A2B	3.7	140	1.0	250
PLY17BS5620R8A2B	5.6	210	0.8	250
PLY17BS7820R7A2B	7.8	290	0.7	250
PLY17BS9320R6A2B	9.3	350	0.6	250

Operating Temperature Range: -25°C to 60°C Winding Temperature Rise (at Rated Current): 60°C (max.)

B Type

Part Number	Common Mode Inductance (min.) (mH)	Normal Mode Inductance (min.) (μH)	Rated Current (A)	Rated Voltage (VAC)
PLY17BS4912R4B2B	0.49	24	2.4	250
PLY17BS9612R0B2B	0.96	47	2.0	250
PLY17BS1023R0B2B	1.0	47	3.0	250
PLY17BS1121R8B2B	1.1	58	1.8	250
PLY17BS1721R5B2B	1.7	88	1.5	250
PLY17BS2921R2B2B	2.9	140	1.2	250
PLY17BS3721R0B2B	3.7	180	1.0	250
PLY17BS5620R8B2B	5.6	280	0.8	250
PLY17BS7820R7B2B	7.8	390	0.7	250
PLY17BS9320R6B2B	9.3	460	0.6	250

Operating Temperature Range: -25°C to 60°C Winding Temperature Rise (at Rated Current): 60°C (max.)

Equivalent Circuit Diagram

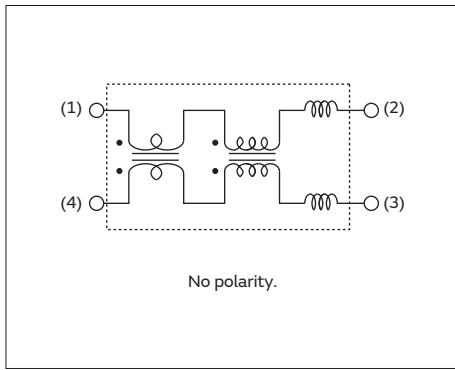

2

Common Mode Insertion Loss - Frequency Characteristics

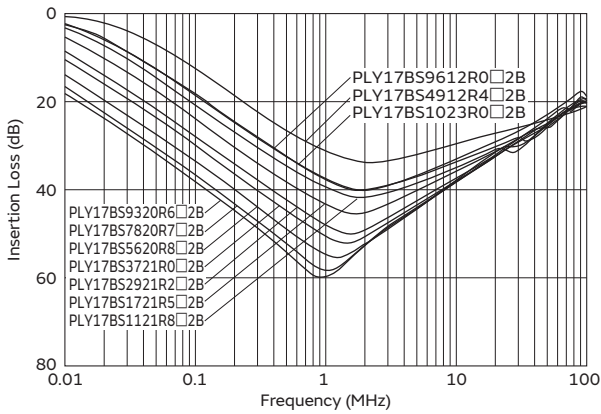

Differential Mode Insertion Loss - Frequency Characteristics

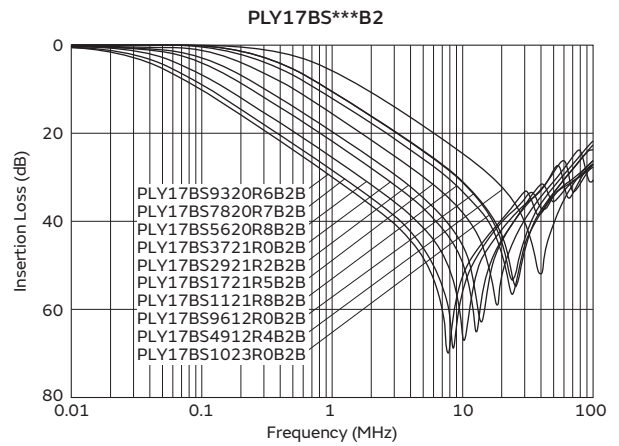
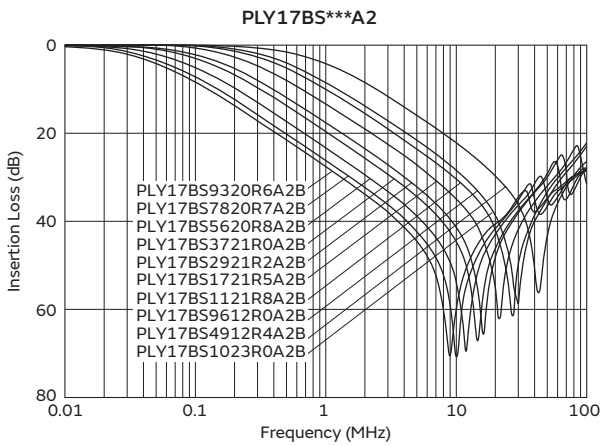

Noise Suppression Effect of PLY10 Series

The data shows noise suppression effects comparison PLY10 with existing common mode choke coil. (In AC adaptor of notebook PC)

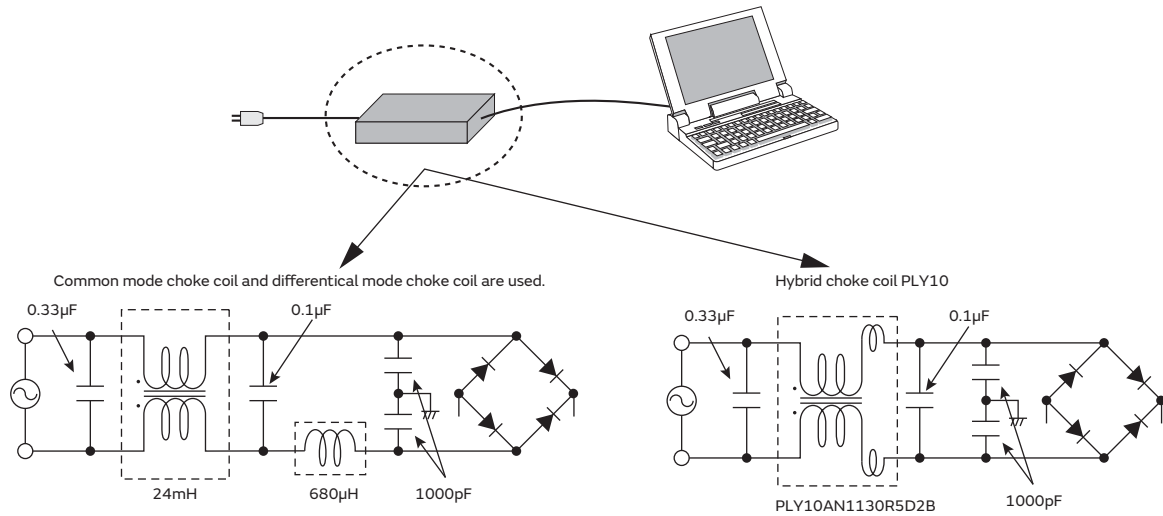

• Noise Level

The filter circuit with hybrid choke coil has suppressed conducted noise as well as a conventional filter in spite of its compact composition.

Common mode choke coil and differential mode choke coil are used.

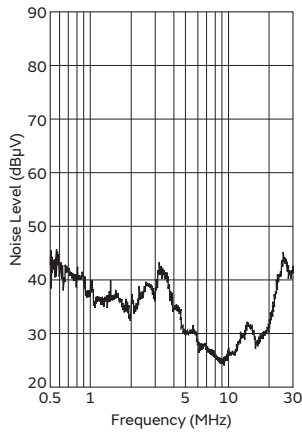

Hybrid choke coil PLY10

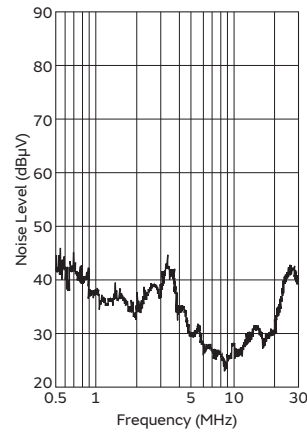

⚠Caution/Notice

⚠Caution (Rating)

1. Rated Current

Operating current should not exceed the rated value. Even if operating current is under the rated value, adequate ventilation is required to avoid excessive heat generated within the product (choke coil) and from surrounding heat sources. If exceeding these conditions, excessive heat may cause fumes or permanent damage to the product. Please ensure that the product (choke coil) is evaluated and confirmed against the specification when it is mounted in your final assembled product.
 -> Winding temperature should be less than 120°C. Maximum allowable temperature at the surface of the coil (ambient temperature + winding temperature rise) is in accordance with each safety standard applicable to the final assembled product.

When the temperature at winding exceeds the maximum allowable temperature of the safety standard, the rated current should be derated.

2. Inrush Current

Inrush current should not exceed 10 times the rated current within 1/4 cycle of 50/60Hz commercial power line. Inrush current should be limited to a minimum of 10 seconds after last inrush.

If these conditions are exceeded, excessive heat may cause fumes or permanent damage to the component, or at worst cause ignition.

Notice (Storage and Operating Conditions)

1. Soldering Conditions

(1) Flux, Solder

- Rosin-based flux should be used. Do not use strong acidic flux with halide content exceeding 0.2wt% (chlorine conversion value)
- Use Sn-3.0Ag-0.5Cu solder

(2) Flow soldering profile

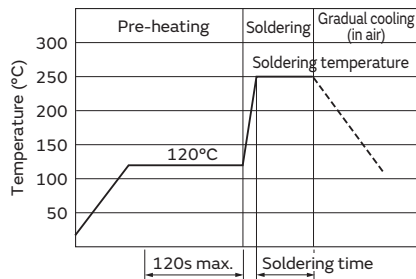

Standard profile		Limit profile		
Sn-3.0Ag-0.5Cu solder				
Soldering temp.	Soldering time	Soldering temp.	Soldering time	Cycle of flow
250±2°C	4-6s	265±3°C	5s	2 times

For additional mounting methods, please contact Murata.

Notice (Soldering and Mounting)

Magnetic Flux Leakage

Choke coils generate small amounts of magnetic flux leakage that may adversely affect equipment operation according to component arrangement. Testing should be completed on final assembly to ensure equipment performance is not affected.

2. Cleaning

Avoid cleaning the product due to non-waterproof construction.

3. Storage and Handling Requirements

(1) Storage period

Product should be used within 12 months after receiving. Solderability should be checked if this period is exceeded.

(2) Storage conditions

Storage Temperature: -10 to 40 °C
 Relative humidity: 30 to 70%
 Avoid sudden changes in temperature and humidity. Don't keep products in corrosive gases such as sulfur, chlorine gas or acid, as it may cause oxidation of lead terminals resulting in poor solderability or corrosion of component windings.

(3) Handling conditions

Care should be taken when transporting or handling the product to avoid excessive vibration or mechanical shock.

Notice (Rating)

Coil Humming Noise

Magnetic flux generated between coil and core or between the choke coil windings creates repulsive power between the coil windings. This repulsive power causes the coil winding to vibrate and create a humming noise. The amount of hum produced by the coil is proportionate to the amount of harmonic distortion generated by the operating current. This does not influence the electrical performance of the coils, but it should be considered and tested in actual circuit application.

Packaging

Minimum Quantity

Part Number	Minimum Quantity (pcs.)
	Box
PLA10	1260
PLH10	1260
PLY10	1200
PLY17	1080

Global Locations

For details please visit www.murata.com



⚠ Note

1 Export Control

For customers outside Japan:

No Murata products should be used or sold, through any channels, for use in the design, development, production, utilization, maintenance or operation of, or otherwise contribution to (1) any weapons (Weapons of Mass Destruction [nuclear, chemical or biological weapons or missiles] or conventional weapons) or (2) goods or systems specially designed or intended for military end-use or utilization by military end-users.

For customers in Japan:

For products which are controlled items subject to the "Foreign Exchange and Foreign Trade Law" of Japan, the export license specified by the law is required for export.

2 Please contact our sales representatives or product engineers before using the products in this catalog for the applications listed below, which require especially high reliability for the prevention of defects which might directly damage a third party's life, body or property, or when one of our products is intended for use in applications other than those specified in this catalog.

- ① Aircraft equipment
- ② Aerospace equipment
- ③ Undersea equipment
- ④ Power plant equipment
- ⑤ Medical equipment
- ⑥ Transportation equipment (vehicles, trains, ships, etc.)
- ⑦ Traffic signal equipment
- ⑧ Disaster prevention / crime prevention equipment
- ⑨ Data-processing equipment
- ⑩ Application of similar complexity and/or reliability requirements to the applications listed above

3 Product specifications in this catalog are as of October 2016. They are subject to change or our products in it may be discontinued without advance notice. Please check with our sales representatives or product engineers before ordering. If there are any questions, please contact our sales representatives or product engineers.

4 Please read rating and ⚠CAUTION (for storage, operating, rating, soldering, mounting and handling) in this catalog to prevent smoking and/or burning, etc.

5 This catalog has only typical specifications. Therefore, please approve our product specifications or transact the approval sheet for product specifications before ordering.

6 Please note that unless otherwise specified, we shall assume no responsibility whatsoever for any conflict or dispute that may occur in connection with the effect of our and/or a third party's intellectual property rights and other related rights in consideration of your use of our products and/or information described or contained in our catalogs. In this connection, no representation shall be made to the effect that any third parties are authorized to use the rights mentioned above under licenses without our consent.

7 No ozone depleting substances (ODS) under the Montreal Protocol are used in our manufacturing process.

Murata Manufacturing Co., Ltd.

www.murata.com

muRata
INNOVATOR IN ELECTRONICS

Looking for pricing, stock, or lifecycle information?

Click below to explore more details on WIN SOURCE:

- ⊖ [View PLY17BS1023R0A2B on WIN SOURCE](#)
- ⊖ [Murata Electronics North America Information](#)

Optimize Your Supply Chain with WIN SOURCE Solutions

- ✓ Global Sourcing Solution
- ✓ Obsolete Management
- ✓ Cost Control Management
- ✓ Shortage Management
- ✓ Alternative Solution
- ✓ Excess Inventory Management