



**THE DATASHEET OF
SN74LVC162244ADLR**



SN74LVC162244A 16-Bit Buffer/Driver with 3-State Outputs

1 Features

- Member of the Texas Instruments Widebus™ Family
- Operates From 1.65 V to 3.6 V
- Inputs Accept Voltages to 5.5 V
- Max t_{pd} of 4.4 ns at 3.3 V
- Typical V_{OLP} (Output Ground Bounce) < 0.8 V at $V_{CC} = 3.3$ V, $T_A = 25^\circ\text{C}$
- Typical V_{OHV} (Output V_{OH} Undershoot) > 2 V at $V_{CC} = 3.3$ V, $T_A = 25^\circ\text{C}$
- Supports Mixed-Mode Signal Operation on All Ports (5-V Input/Output Voltage With 3.3-V V_{CC})
- Output Ports Have Equivalent 26 Ω Series Resistors, So No External Resistors Are Required
- I_{off} Supports Live Insertion, Partial Power Down Mode, and Back Drive Protection
- Latch-Up Performance Exceeds 100 mA Per JESD 78, Class II
- ESD Protection Exceeds JESD 22
 - 2000-V Human-Body Model (A114-A)
 - 1000-V Charged-Device Model (C101)

2 Applications

- Motor drive
- Network switch
- Power Infrastructure
- Test and Measurement

3 Description

This 16-bit buffer or driver is designed for 1.65-V to 3.6-V V_{CC} operation. The device can be used as four 4-bit buffers, two 8-bit buffers, or one 16-bit buffer.

Device Information⁽¹⁾

PART NUMBER	PACKAGE	BODY SIZE (NOM)
SN74LVC162244A	SSOP (48)	15.88 × 7.49 mm
	TSSOP (48)	12.50 × 6.10 mm
	TVSOP (48)	9.70 × 4.40 mm

(1) For all available packages, see the orderable addendum at the end of the data sheet.

4 Simplified Schematic

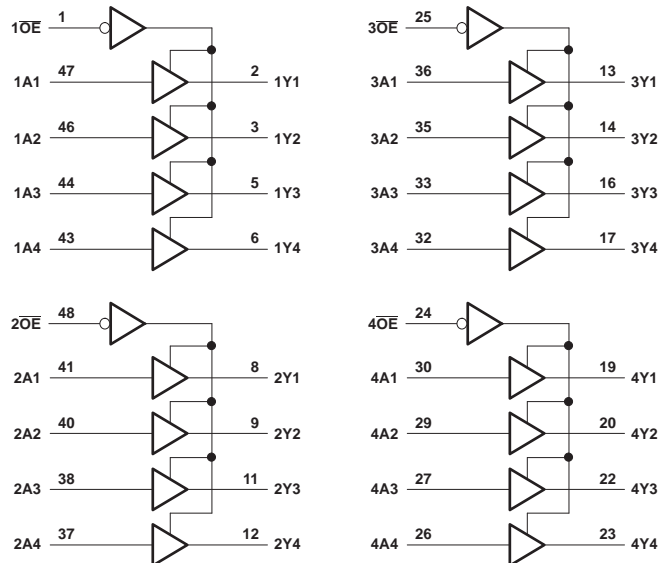

Pin numbers shown are for the DGG, DGV, and DL packages.



Table of Contents

1 Features	1	9.1 Overview	11
2 Applications	1	9.2 Functional Block Diagram	11
3 Description	1	9.3 Feature Description	11
4 Simplified Schematic	1	9.4 Device Functional Modes	12
5 Revision History	2	10 Application and Implementation	12
6 Pin Configuration and Functions	3	10.1 Application Information	12
7 Specifications	6	10.2 Typical Application	12
7.1 Absolute Maximum Ratings	6	11 Power Supply Recommendations	13
7.2 Handling Ratings	6	12 Layout	14
7.3 Recommended Operating Conditions	7	12.1 Layout Guidelines	14
7.4 Thermal Information	7	12.2 Layout Example	14
7.5 Electrical Characteristics	8	13 Device and Documentation Support	14
7.6 Switching Characteristics	8	13.1 Trademarks	14
7.7 Operating Characteristics	8	13.2 Electrostatic Discharge Caution	14
7.8 Typical Characteristics	9	13.3 Glossary	14
8 Parameter Measurement Information	10	14 Mechanical, Packaging, and Orderable Information	14
9 Detailed Description	11		

5 Revision History

NOTE: Page numbers for previous revisions may differ from page numbers in the current version.

Changes from Revision A (October 2005) to Revision B	Page
• Updated document to new TI data sheet format	1
• Removed Ordering Information table	1
• Added Applications	1
• Changed MAX ambient temperature to 125°C	7
• Added Device and Documentation Support section	14
• Added ESD warning	14
• Added Mechanical, Packaging, and Orderable Information section	14

6 Pin Configuration and Functions

DGG, DGV, OR DL PACKAGE
(TOP VIEW)

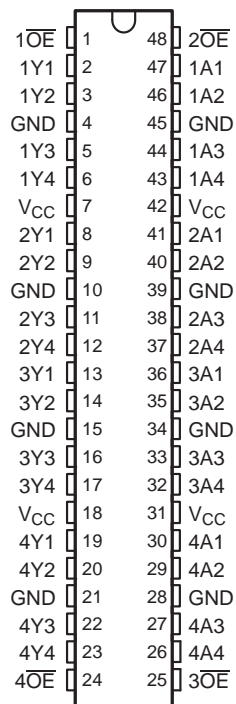

Pin Functions

PIN		I/O	DESCRIPTION
NAME	NO.		
1OE	1	I	Output Enable 1 (input)
1Y1	2	O	1Y1 Output
1Y2	3	O	1Y2 Output
GND	4	–	Ground pin
1Y3	5	O	1Y3 Output
1Y4	6	O	1Y4 Output
V _{CC}	7	–	Power pin
2Y1	8	O	2Y1 Output
2Y2	9	O	2Y2 Output
GND	10	–	Ground pin
2Y3	11	O	2Y3 Output
2Y4	12	O	2Y4 Output
3Y1	13	O	3Y1 Output
3Y2	14	O	3Y2 Output
GND	15	–	Ground pin
3Y3	16	O	3Y3 Output
3Y4	17	O	3Y4 Output
V _{CC}	18	–	Power pin
4Y1	19	O	4Y1 Output
4Y2	20	O	4Y2 Output
GND	21	–	Ground pin
4Y3	22	O	4Y3 Output

Pin Functions (continued)

PIN		I/O	DESCRIPTION
NAME	NO.		
4Y4	23	O	4Y4 Output
4OE	24	I	Output Enable 4 (input)
3OE	25	I	Output Enable 3 (input)
4A4	26	I	4A4 Input
4A3	27	I	4A3 Input
GND	28	–	Ground pin
4A2	29	I	4A2 Input
4A1	30	I	4A1 Input
V _{CC}	31	–	Power pin
3A4	32	I	3A4 Input
3A3	33	I	3A3 Input
GND	34	–	Ground pin
3A2	35	I	3A2 Input
3A1	36	I	3A1 Input
2A4	37	I	2A4 Input
2A3	38	I	2A3 Input
GND	39	–	Ground pin
2A2	40	I	2A2 Input
2A1	41	I	2A1 Input
V _{CC}	42	–	Power pin
1A4	43	I	1A4 Input
1A3	44	I	1A3 Input
GND	45	–	Ground pin
1A2	46	I	1A2 Input
1A1	47	I	1A1 Input
2OE	48	I	Output Enable 2 (Input)

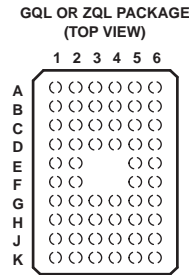

**Table 1. 3Pin Assignments⁽¹⁾
(56-Ball GQL or ZQL Package)**

	1	2	3	4	5	6
A	1 \overline{OE}	NC	NC	NC	NC	2 \overline{OE}
B	1Y2	1Y1	GND	GND	1A1	1A2
C	1Y4	1Y3	V _{CC}	V _{CC}	1A3	1A4
D	2Y2	2Y1	GND	GND	2A1	2A2
E	2Y4	2Y3			2A3	2A4
F	3Y1	3Y2			3A2	3A1
G	3Y3	3Y4	GND	GND	3A4	3A3
H	4Y1	4Y2	V _{CC}	V _{CC}	4A2	4A1
J	4Y3	4Y4	GND	GND	4A4	4A3
K	4 \overline{OE}	NC	NC	NC	NC	3 \overline{OE}

(1) NC - No internal connection

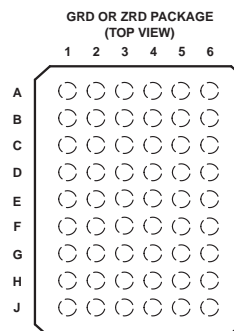

**Table 2. Pin Assignments⁽¹⁾
(54-Ball GRD or ZRD Package)**

	1	2	3	4	5	6
A	1Y1	NC	1 \overline{OE}	2 \overline{OE}	NC	1A1
B	1Y3	1Y2	NC	NC	1A2	1A3
C	2Y1	1Y4	V _{CC}	V _{CC}	1A4	2A1
D	2Y3	2Y2	GND	GND	2A2	2A3
E	3Y1	2Y4	GND	GND	2A4	3A1
F	3Y3	3Y2	GND	GND	3A2	3A3
G	4Y1	3Y4	V _{CC}	V _{CC}	3A4	4A1
H	4Y3	4Y2	NC	NC	4A2	4A3
J	4Y4	NC	4 \overline{OE}	3 \overline{OE}	NC	4A4

(1) NC - No internal connection

7 Specifications

7.1 Absolute Maximum Ratings⁽¹⁾

over operating free-air temperature range (unless otherwise noted)

		MIN	MAX	UNIT
V _{CC}	Supply voltage range	-0.5	6.5	V
V _I	Input voltage range ⁽²⁾	-0.5	6.5	V
V _O	Voltage range applied to any output in the high-impedance or power-off state ⁽²⁾	-0.5	6.5	V
V _O	Voltage range applied to any output in the high or low state ⁽²⁾⁽³⁾	-0.5	V _{CC} + 0.5	V
I _{IK}	Input clamp current	V _I < 0		-50 mA
I _{OK}	Output clamp current	V _O < 0		-50 mA
I _O	Continuous output current			±50 mA
Continuous current through each V _{CC} or GND				±100 mA

- (1) Stresses beyond those listed under *Absolute Maximum Ratings* may cause permanent damage to the device. These are stress ratings only, and functional operation of the device at these or any other conditions beyond those indicated under *Recommended Operating Conditions* is not implied. Exposure to absolute-maximum-rated conditions for extended periods may affect device reliability.
- (2) The input negative-voltage and output voltage ratings may be exceeded if the input and output current ratings are observed.
- (3) The value of V_{CC} is provided in the *Recommended Operating Conditions* table.

7.2 Handling Ratings

		MIN	MAX	UNIT
T _{stg}	Storage temperature range	-65	150	°C
V _(ESD)	Electrostatic discharge	Human body model (HBM), per ANSI/ESDA/JEDEC JS-001, all pins ⁽¹⁾		V
		Charged device model (CDM), per JEDEC specification JESD22-C101, all pins ⁽²⁾		

- (1) JEDEC document JEP155 states that 500-V HBM allows safe manufacturing with a standard ESD control process.
- (2) JEDEC document JEP157 states that 250-V CDM allows safe manufacturing with a standard ESD control process.

7.3 Recommended Operating Conditions

 over operating free-air temperature range (unless otherwise noted)⁽¹⁾

		MIN	MAX	UNIT	
V _{CC}	Supply voltage	Operating	1.65	3.6	V
		Data retention only	1.5		
V _{IH}	High-level input voltage	V _{CC} = 1.65 V to 1.95 V	0.65 × V _{CC}		V
		V _{CC} = 2.3 V to 2.7 V	1.7		
		V _{CC} = 2.7 V to 3.6 V	2		
V _{IL}	Low-level input voltage	V _{CC} = 1.65 V to 1.95 V		0.35 × V _{CC}	V
		V _{CC} = 2.3 V to 2.7 V		0.7	
		V _{CC} = 2.7 V to 3.6 V		0.8	
V _I	Input voltage	0	5.5	V	
V _O	Output voltage	High or low state	0	V _{CC}	V
		High-impedance state	0	5.5	
I _{OH}	High-level output current	V _{CC} = 1.65 V		-2	mA
		V _{CC} = 2.3 V		-4	
		V _{CC} = 2.7 V		-8	
		V _{CC} = 3 V		-12	
I _{OL}	Low-level output current	V _{CC} = 1.65 V		2	mA
		V _{CC} = 2.3 V		4	
		V _{CC} = 2.7 V		8	
		V _{CC} = 3 V		12	
Δt/Δv	Input transition rise or fall rate		10	ns/V	
T _A	Operating free-air temperature	-40	125	°C	

(1) All unused inputs of the device must be held at V_{CC} or GND to ensure proper device operation. Refer to the TI application report, *Implications of Slow or Floating CMOS Inputs*, literature number [SCBA004](#).

7.4 Thermal Information

THERMAL METRIC ⁽¹⁾		DGG	DGV	DL	UNIT
		48 PINS	48 PINS	48 PINS	
R _{θJA}	Junction-to-ambient thermal resistance	64.3	78.4	68.4	°C/W
R _{θJC(top)}	Junction-to-case (top) thermal resistance	17.6	30.7	34.7	
R _{θJB}	Junction-to-board thermal resistance	31.5	41.8	41.0	
Ψ _{JT}	Junction-to-top characterization parameter	1.1	3.8	12.3	
Ψ _{JB}	Junction-to-board characterization parameter	31.2	41.3	40.4	

(1) For more information about traditional and new thermal metrics, see the *IC Package Thermal Metrics* application report, [SPRA953](#).

7.5 Electrical Characteristics

over recommended operating free-air temperature range (unless otherwise noted)

PARAMETER	TEST CONDITIONS	V_{CC}	MIN	TYP ⁽¹⁾	MAX	UNIT	
V_{OH}	$I_{OH} = -100 \mu A$	1.65 V to 3.6 V	$V_{CC} - 0.2$			V	
	$I_{OH} = -2 \text{ mA}$	1.65 V	1.2				
	$I_{OH} = -4 \text{ mA}$	2.3 V	1.7				
		2.7 V	2.2				
	$I_{OH} = -6 \text{ mA}$	3 V	2.4				
	$I_{OH} = -8 \text{ mA}$	2.7 V	2				
V_{OL}	$I_{OL} = 100 \mu A$	1.65 V to 3.6 V	0.2			V	
	$I_{OL} = 2 \text{ mA}$	1.65 V	0.45				
	$I_{OL} = 4 \text{ mA}$	2.3 V	0.7				
		2.7 V	0.4				
	$I_{OL} = 6 \text{ mA}$	3 V	0.55				
	$I_{OL} = 8 \text{ mA}$	2.7 V	0.6				
	$I_{OL} = 12 \text{ mA}$	3 V	0.8				
I_I	$V_I = 0 \text{ to } 5.5 \text{ V}$	3.6 V	± 5			μA	
I_{off}	$V_I \text{ or } V_O = 5.5 \text{ V}$	0	± 10			μA	
I_{OZ}	$V_O = 0 \text{ to } 5.5 \text{ V}$	3.6 V	± 10			μA	
I_{CC}	$V_I = V_{CC} \text{ or GND}$	3.6 V	$I_O = 0$			20	μA
	$3.6 \text{ V} \leq V_I \leq 5.5 \text{ V}^{(2)}$					20	
ΔI_{CC}	One input at $V_{CC} - 0.6 \text{ V}$, Other inputs at $V_{CC} \text{ or GND}$	2.7 V to 3.6 V	500			μA	
C_i	$V_I = V_{CC} \text{ or GND}$	3.3 V	5.5			pF	
C_o	$V_O = V_{CC} \text{ or GND}$	3.3 V	6			pF	

 (1) All typical values are at $V_{CC} = 3.3 \text{ V}$, $T_A = 25^\circ\text{C}$.

(2) This applies in the disabled state only.

7.6 Switching Characteristics

 over recommended operating free-air temperature range (unless otherwise noted) (see [Figure 3](#))

PARAMETER	FROM (INPUT)	TO (OUTPUT)	$V_{CC} = 1.8 \text{ V} \pm 0.15 \text{ V}$		$V_{CC} = 2.5 \text{ V} \pm 0.2 \text{ V}$		$V_{CC} = 2.7 \text{ V}$		$V_{CC} = 3.3 \text{ V} \pm 0.3 \text{ V}$		UNIT
			MIN	MAX	MIN	MAX	MIN	MAX	MIN	MAX	
t_{pd}	A	Y	1.5	6	1	4.3	1	5.6	1.1	4.4	ns
t_{en}	\overline{OE}	Y	1.5	7.3	1	5	1	6.9	1	5.5	ns
t_{dis}	\overline{OE}	Y	1.5	8.9	1	5.5	1	6.8	1.8	6.3	ns

7.7 Operating Characteristics

 $T_A = 25^\circ\text{C}$

PARAMETER	TEST CONDITIONS	$V_{CC} = 1.8 \text{ V}$	$V_{CC} = 2.5 \text{ V}$	$V_{CC} = 3.3 \text{ V}$	UNIT	
		TYP	TYP	TYP		
C_{pd} Power dissipation capacitance per buffer/driver	Outputs enabled	f = 10 MHz	31	33	35	pF
	Outputs disabled		2	3	4	

7.8 Typical Characteristics

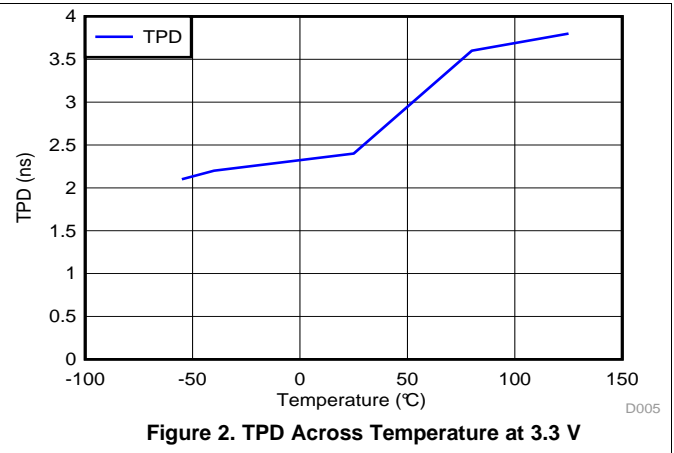
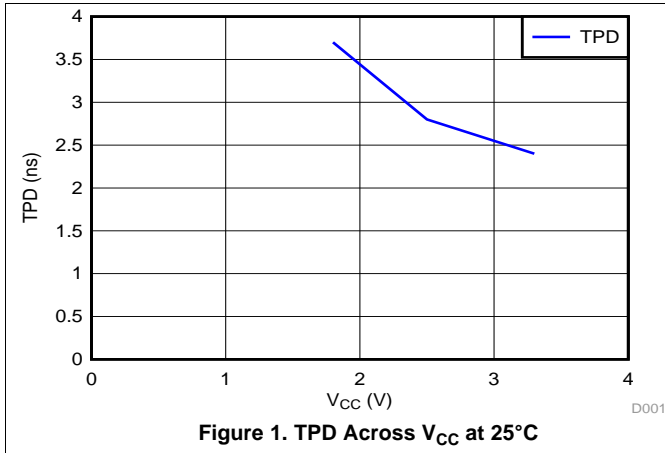

8 Parameter Measurement Information

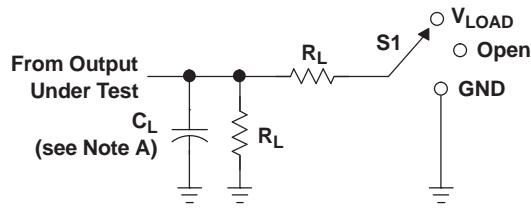
LOAD CIRCUIT

TEST	S1
t_{PLH}/t_{PHL}	Open
t_{PLZ}/t_{PZL}	V_{LOAD}
t_{PHZ}/t_{PZH}	GND

V_{CC}	INPUTS		V_M	V_{LOAD}	C_L	R_L	V_{Δ}
	V_I	t_r/t_f					
$1.8\text{ V} \pm 0.15\text{ V}$	V_{CC}	$\leq 2\text{ ns}$	$V_{CC}/2$	$2 \times V_{CC}$	30 pF	1 k Ω	0.15 V
$2.5\text{ V} \pm 0.2\text{ V}$	V_{CC}	$\leq 2\text{ ns}$	$V_{CC}/2$	$2 \times V_{CC}$	30 pF	500 Ω	0.15 V
2.7 V	2.7 V	$\leq 2.5\text{ ns}$	1.5 V	6 V	50 pF	500 Ω	0.3 V
$3.3\text{ V} \pm 0.3\text{ V}$	2.7 V	$\leq 2.5\text{ ns}$	1.5 V	6 V	50 pF	500 Ω	0.3 V

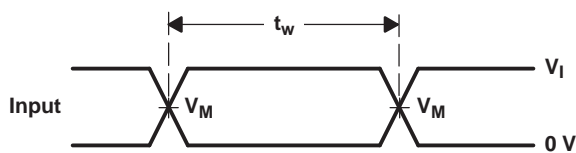
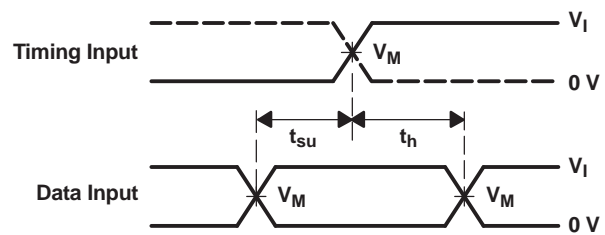
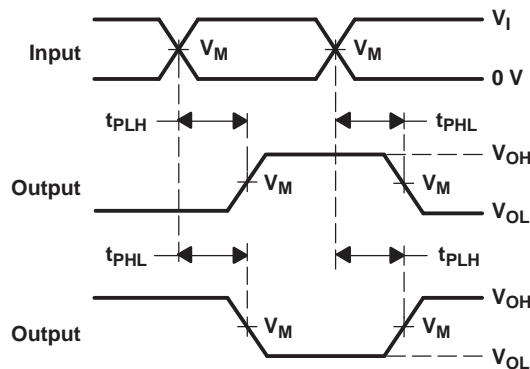
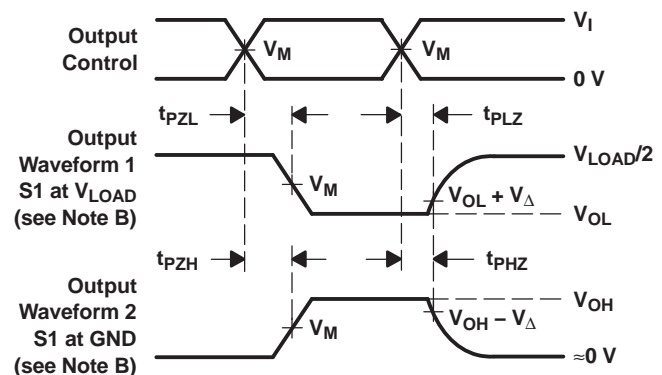
**VOLTAGE WAVEFORMS
PULSE DURATION**

**VOLTAGE WAVEFORMS
SETUP AND HOLD TIMES**

**VOLTAGE WAVEFORMS
PROPAGATION DELAY TIMES
INVERTING AND NONINVERTING OUTPUTS**

**VOLTAGE WAVEFORMS
ENABLE AND DISABLE TIMES
LOW- AND HIGH-LEVEL ENABLING**

- NOTES:
- C_L includes probe and jig capacitance.
 - Waveform 1 is for an output with internal conditions such that the output is low, except when disabled by the output control. Waveform 2 is for an output with internal conditions such that the output is high, except when disabled by the output control.
 - All input pulses are supplied by generators having the following characteristics: $PRR \leq 10\text{ MHz}$, $Z_O = 50\ \Omega$.
 - The outputs are measured one at a time, with one transition per measurement.
 - t_{PLZ} and t_{PHZ} are the same as t_{dis} .
 - t_{PZL} and t_{PZH} are the same as t_{en} .
 - t_{PLH} and t_{PHL} are the same as t_{pd} .
 - All parameters and waveforms are not applicable to all devices.

Figure 3. Load Circuit and Voltage Waveforms

9 Detailed Description

9.1 Overview

This 16-bit buffer/driver is designed for 1.65-V to 3.6-V V_{CC} operation. The SN74LVC162244A is designed specifically to improve the performance and density of 3-state memory address drivers, clock drivers, and bus-oriented receivers and transmitters. The device can be used as four 4-bit buffers, two 8-bit buffers, or one 16-bit buffer. It provides true outputs and symmetrical active-low output-enable (\overline{OE}) inputs.

Inputs can be driven from either 3.3-V or 5-V devices. This feature allows the use of this device as a translator in a mixed 3.3-V/5-V system environment. The outputs, which are designed to sink up to 12 mA, include equivalent 26- Ω resistors to reduce overshoot and undershoot. Inputs can be driven from either 3.3-V or 5-V devices. This feature allows the use of this device as a translator in a mixed 3.3-V/5-V system environment. This device is fully specified for partial-power-down applications using I_{off} . The I_{off} circuitry disables the outputs, preventing damaging current backflow through the device when it is powered down. To ensure the high-impedance state during power up or power down, \overline{OE} should be tied to V_{CC} through a pullup resistor; the minimum value of the resistor is determined by the current-sinking capability of the driver.

9.2 Functional Block Diagram

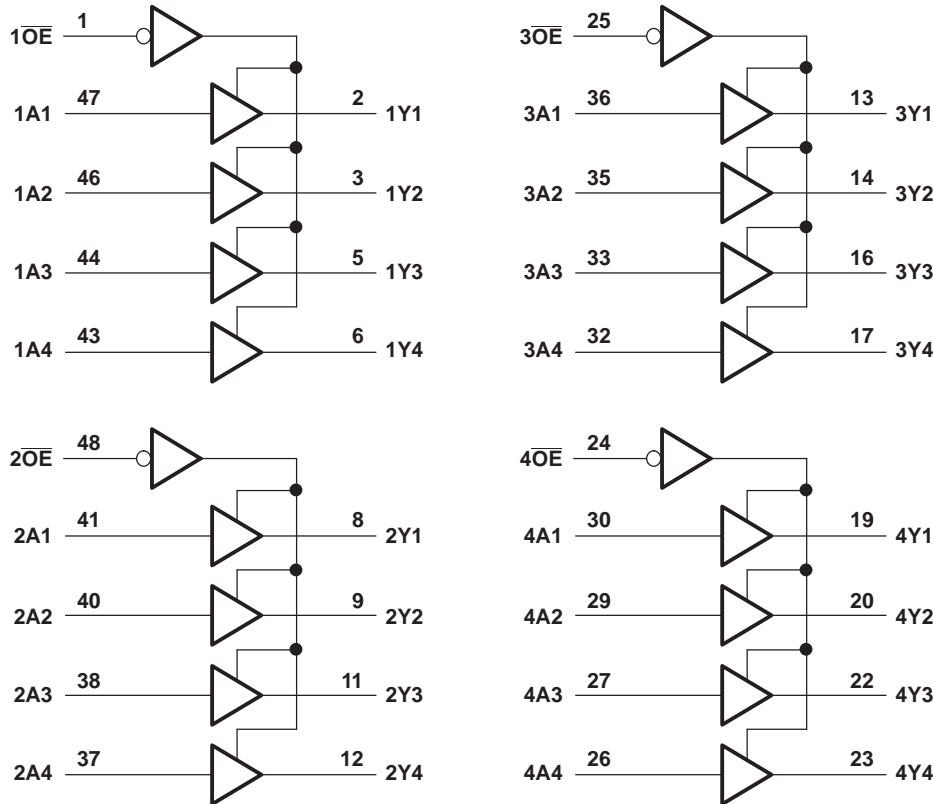

Pin numbers shown are for the DGG, DGV, and DL packages.

9.3 Feature Description

- Wide operating voltage range
 - Operates from 1.65 V to 3.6 V
- Allows down voltage translation
 - Inputs accept voltages to 5.5 V
- I_{off} feature
 - Allows voltages on the inputs and outputs when V_{CC} is 0 V

9.4 Device Functional Modes

**Table 3. Function Table
(Each 4-Bit Buffer)**

INPUTS		OUTPUT Y
$\overline{\text{OE}}$	A	
L	H	H
L	L	L
H	X	Z

10 Application and Implementation

10.1 Application Information

The SN74LVC162244A is a 16 bit buffer driver. This device can be used as four 4-bit, two 8-bit, or one 16-bit buffer. It allows data transmission from the A bus to the Y bus with 4 separate enable pins that control 4 bits each. The output-enable ($\overline{\text{OE}}$) input can be used to disable sections of the device so the buses are effectively isolated. The device has 5.5 V tolerant inputs at any valid V_{CC} which allows it to be used in multi-power systems and can be used for down translation.

10.2 Typical Application

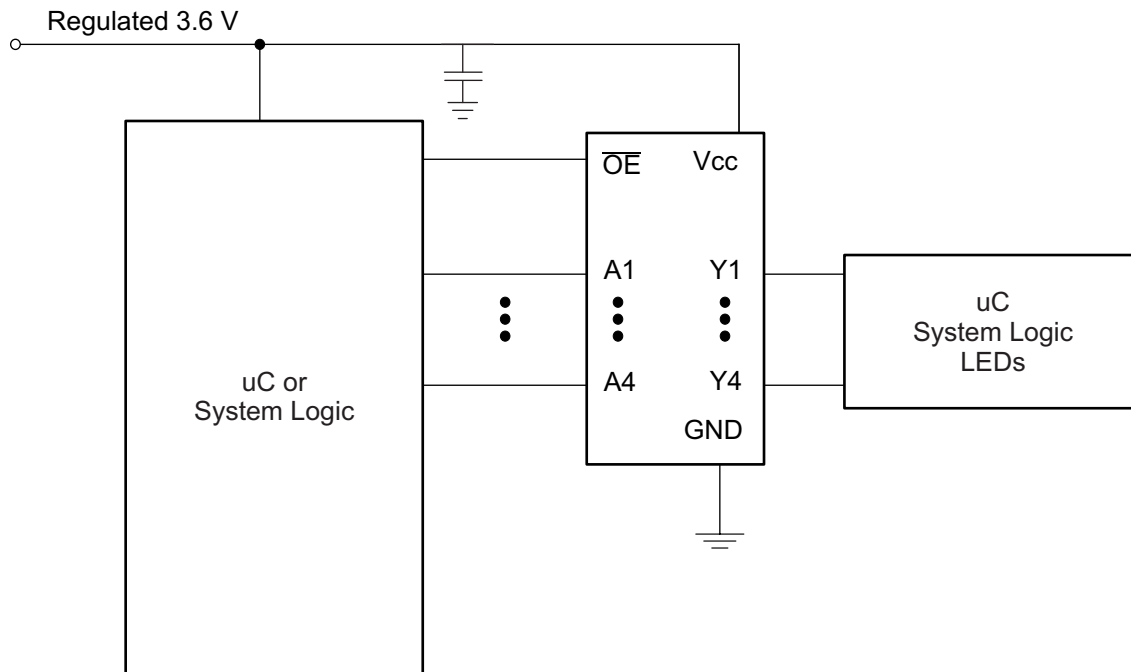

Figure 4. Typical Application Schematic

Typical Application (continued)

10.2.1 Design Requirements

This device uses CMOS technology and has balanced output drive. Care should be taken to avoid bus contention because it can drive currents that would exceed maximum limits. The high drive will also create fast edges into light loads so routing and load conditions should be considered to prevent ringing.

10.2.2 Detailed Design Procedure

1. Recommended Input Conditions
 - Rise time and fall time specs: See $(\Delta t/\Delta V)$ in the [Recommended Operating Conditions](#) table.
 - Specified high and low levels: See $(V_{IH}$ and $V_{IL})$ in the [Recommended Operating Conditions](#) table.
 - Inputs are overvoltage tolerant allowing them to go as high as 5.5 V at any valid V_{CC} .
2. Recommended Output Conditions
 - Load currents should not exceed 25 mA per output and 50 mA total for the part.
 - Outputs should not be pulled above V_{CC} .

10.2.3 Application Curves

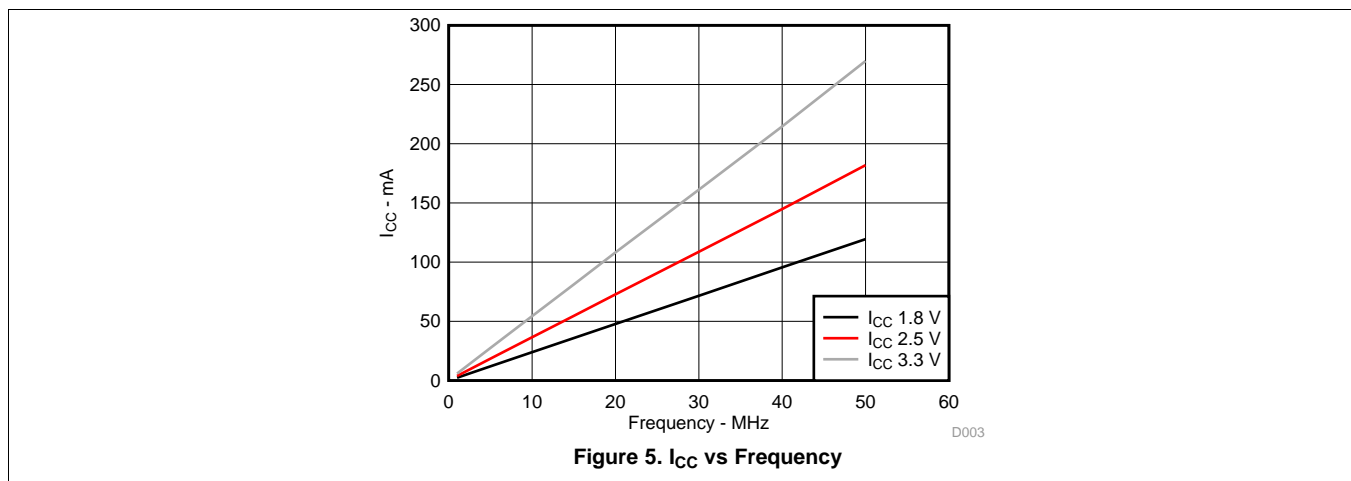

11 Power Supply Recommendations

The power supply can be any voltage between the MIN and MAX supply voltage rating located in the [Recommended Operating Conditions](#) table.

Each V_{CC} pin should have a good bypass capacitor to prevent power disturbance. For devices with a single supply, 0.1 μF is recommended; if there are multiple V_{CC} pins, then 0.01 μF or 0.022 μF is recommended for each power pin. It is acceptable to parallel multiple bypass caps to reject different frequencies of noise. A 0.1 μF and a 1 μF are commonly used in parallel. The bypass capacitor should be installed as close to the power pin as possible for best results.

12 Layout

12.1 Layout Guidelines

When using multiple bit logic devices inputs should not ever float.

In many cases, functions or parts of functions of digital logic devices are unused, for example, when only two inputs of a triple-input AND gate are used or only 3 of the 4 buffer gates are used. Such input pins should not be left unconnected because the undefined voltages at the outside connections result in undefined operational states. Specified below are the rules that must be observed under all circumstances. All unused inputs of digital logic devices must be connected to a high or low bias to prevent them from floating. The logic level that should be applied to any particular unused input depends on the function of the device. Generally they will be tied to GND or V_{CC} whichever make more sense or is more convenient. It is generally OK to float outputs unless the part is a transceiver. If the transceiver has an output enable pin it will disable the outputs section of the part when asserted. This will not disable the input section of the IOs, so they also cannot float when disabled.

12.2 Layout Example

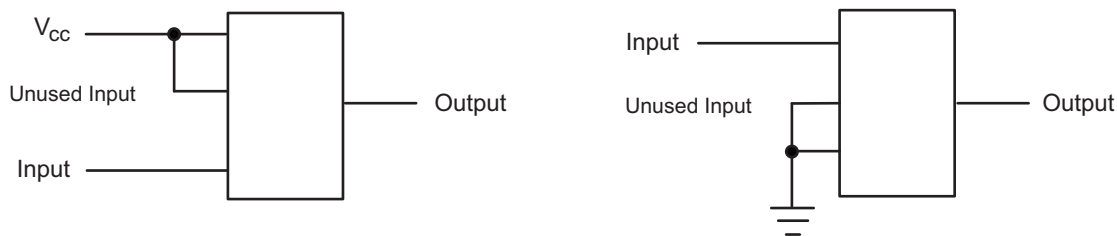

Figure 6. Layout Diagram

13 Device and Documentation Support

13.1 Trademarks

Widebus is a trademark of Texas Instruments.
All other trademarks are the property of their respective owners.

13.2 Electrostatic Discharge Caution



These devices have limited built-in ESD protection. The leads should be shorted together or the device placed in conductive foam during storage or handling to prevent electrostatic damage to the MOS gates.

13.3 Glossary

[SLYZ022](#) — *TI Glossary*.

This glossary lists and explains terms, acronyms and definitions.

14 Mechanical, Packaging, and Orderable Information

The following pages include mechanical, packaging, and orderable information. This information is the most current data available for the designated devices. This data is subject to change without notice and revision of this document. For browser-based versions of this data sheet, refer to the left-hand navigation.

PACKAGING INFORMATION

Orderable Device	Status (1)	Package Type	Package Drawing	Pins	Package Qty	Eco Plan (2)	Lead/Ball Finish (6)	MSL Peak Temp (3)	Op Temp (°C)	Device Marking (4/5)	Samples
74LVC162244ADGGRG4	ACTIVE	TSSOP	DGG	48	2000	Green (RoHS & no Sb/Br)	CU NIPDAU	Level-1-260C-UNLIM	-40 to 125	LVC162244A	Samples
SN74LVC162244ADGGR	ACTIVE	TSSOP	DGG	48	2000	Green (RoHS & no Sb/Br)	CU NIPDAU	Level-1-260C-UNLIM	-40 to 125	LVC162244A	Samples
SN74LVC162244ADGVR	ACTIVE	TVSOP	DGV	48	2000	Green (RoHS & no Sb/Br)	CU NIPDAU	Level-1-260C-UNLIM	-40 to 125	LD2244A	Samples
SN74LVC162244ADL	ACTIVE	SSOP	DL	48	25	Green (RoHS & no Sb/Br)	CU NIPDAU	Level-1-260C-UNLIM	-40 to 125	LVC162244A	Samples
SN74LVC162244ADLG4	ACTIVE	SSOP	DL	48	25	Green (RoHS & no Sb/Br)	CU NIPDAU	Level-1-260C-UNLIM	-40 to 125	LVC162244A	Samples
SN74LVC162244ADLR	ACTIVE	SSOP	DL	48	1000	Green (RoHS & no Sb/Br)	CU NIPDAU	Level-1-260C-UNLIM	-40 to 125	LVC162244A	Samples
SN74LVC162244AZQLR	ACTIVE	BGA MICROSTAR JUNIOR	ZQL	56	1000	Green (RoHS & no Sb/Br)	SNAGCU	Level-1-260C-UNLIM	-40 to 85	LD2244A	Samples

(1) The marketing status values are defined as follows:

ACTIVE: Product device recommended for new designs.

LIFEBUY: TI has announced that the device will be discontinued, and a lifetime-buy period is in effect.

NRND: Not recommended for new designs. Device is in production to support existing customers, but TI does not recommend using this part in a new design.

PREVIEW: Device has been announced but is not in production. Samples may or may not be available.

OBSOLETE: TI has discontinued the production of the device.

(2) **RoHS:** TI defines "RoHS" to mean semiconductor products that are compliant with the current EU RoHS requirements for all 10 RoHS substances, including the requirement that RoHS substance do not exceed 0.1% by weight in homogeneous materials. Where designed to be soldered at high temperatures, "RoHS" products are suitable for use in specified lead-free processes. TI may reference these types of products as "Pb-Free".

RoHS Exempt: TI defines "RoHS Exempt" to mean products that contain lead but are compliant with EU RoHS pursuant to a specific EU RoHS exemption.

Green: TI defines "Green" to mean the content of Chlorine (Cl) and Bromine (Br) based flame retardants meet JS709B low halogen requirements of <=1000ppm threshold. Antimony trioxide based flame retardants must also meet the <=1000ppm threshold requirement.

(3) MSL, Peak Temp. - The Moisture Sensitivity Level rating according to the JEDEC industry standard classifications, and peak solder temperature.

(4) There may be additional marking, which relates to the logo, the lot trace code information, or the environmental category on the device.

⁽⁵⁾ Multiple Device Markings will be inside parentheses. Only one Device Marking contained in parentheses and separated by a "-" will appear on a device. If a line is indented then it is a continuation of the previous line and the two combined represent the entire Device Marking for that device.

⁽⁶⁾ Lead/Ball Finish - Orderable Devices may have multiple material finish options. Finish options are separated by a vertical ruled line. Lead/Ball Finish values may wrap to two lines if the finish value exceeds the maximum column width.

Important Information and Disclaimer:The information provided on this page represents TI's knowledge and belief as of the date that it is provided. TI bases its knowledge and belief on information provided by third parties, and makes no representation or warranty as to the accuracy of such information. Efforts are underway to better integrate information from third parties. TI has taken and continues to take reasonable steps to provide representative and accurate information but may not have conducted destructive testing or chemical analysis on incoming materials and chemicals. TI and TI suppliers consider certain information to be proprietary, and thus CAS numbers and other limited information may not be available for release.

In no event shall TI's liability arising out of such information exceed the total purchase price of the TI part(s) at issue in this document sold by TI to Customer on an annual basis.

TAPE AND REEL INFORMATION



QUADRANT ASSIGNMENTS FOR PIN 1 ORIENTATION IN TAPE



*All dimensions are nominal

Device	Package Type	Package Drawing	Pins	SPQ	Reel Diameter (mm)	Reel Width W1 (mm)	A0 (mm)	B0 (mm)	K0 (mm)	P1 (mm)	W (mm)	Pin1 Quadrant
SN74LVC162244ADGGR	TSSOP	DGG	48	2000	330.0	24.4	8.6	13.0	1.8	12.0	24.0	Q1
SN74LVC162244ADGVR	TVSOP	DGV	48	2000	330.0	16.4	7.1	10.2	1.6	12.0	16.0	Q1
SN74LVC162244ADLR	SSOP	DL	48	1000	330.0	32.4	11.35	16.2	3.1	16.0	32.0	Q1
SN74LVC162244AZQLR	BGA MICROSTAR JUNIOR	ZQL	56	1000	330.0	16.4	4.8	7.3	1.5	8.0	16.0	Q1

TAPE AND REEL BOX DIMENSIONS



*All dimensions are nominal

Device	Package Type	Package Drawing	Pins	SPQ	Length (mm)	Width (mm)	Height (mm)
SN74LVC162244ADGGR	TSSOP	DGG	48	2000	367.0	367.0	45.0
SN74LVC162244ADGVR	TVSOP	DGV	48	2000	367.0	367.0	38.0
SN74LVC162244ADLR	SSOP	DL	48	1000	367.0	367.0	55.0
SN74LVC162244AZQLR	BGA MICROSTAR JUNIOR	ZQL	56	1000	350.0	350.0	43.0

MECHANICAL DATA

DL (R-PDSO-G48)

PLASTIC SMALL-OUTLINE PACKAGE



- NOTES:
- All linear dimensions are in inches (millimeters).
 - This drawing is subject to change without notice.
 - Body dimensions do not include mold flash or protrusion not to exceed 0.006 (0,15).
 - Falls within JEDEC MO-118

PowerPAD is a trademark of Texas Instruments.

DGG (R-PDSO-G**)

PLASTIC SMALL-OUTLINE PACKAGE

48 PINS SHOWN

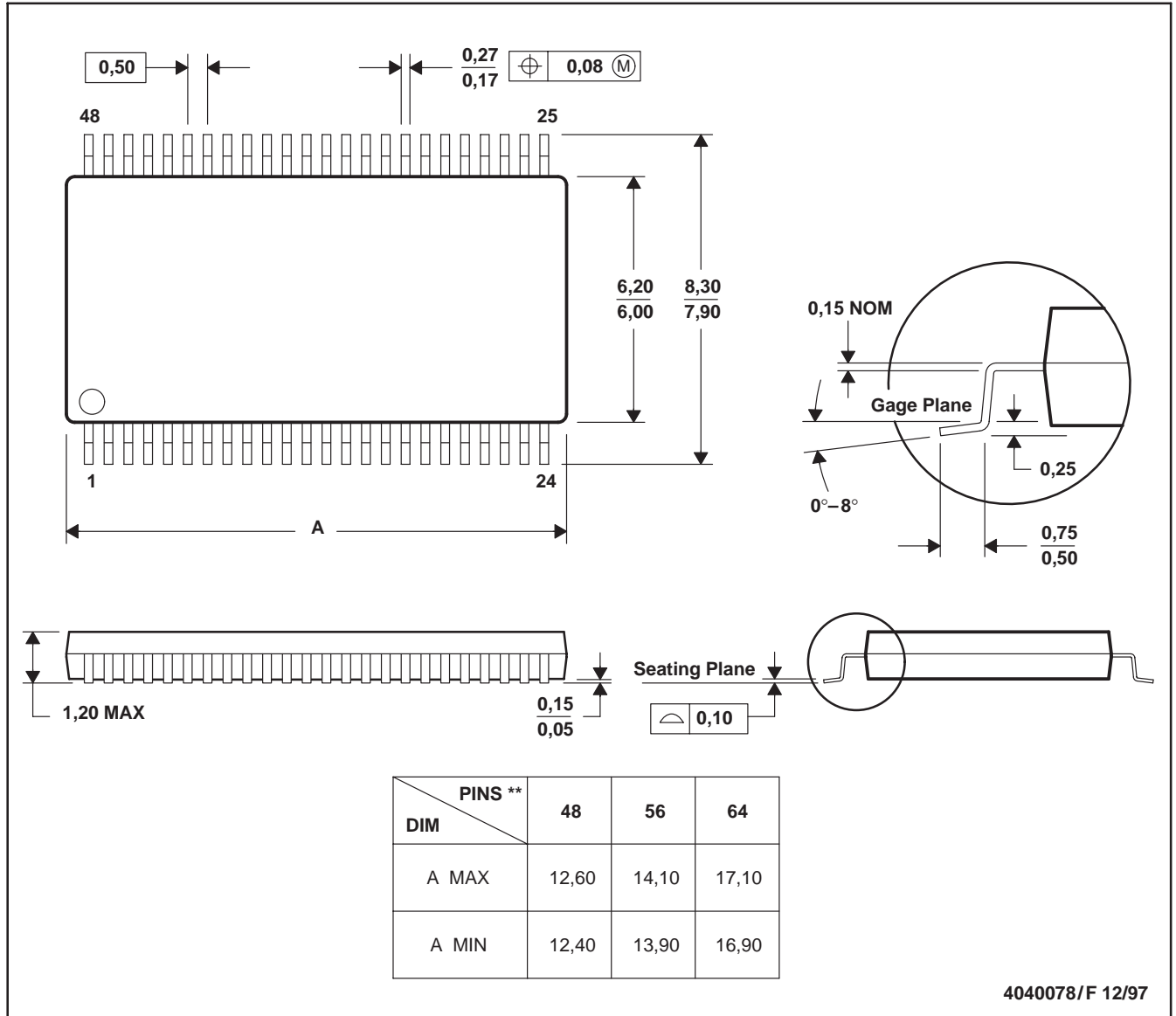

- NOTES: A. All linear dimensions are in millimeters.
 B. This drawing is subject to change without notice.
 C. Body dimensions do not include mold protrusion not to exceed 0,15.
 D. Falls within JEDEC MO-153

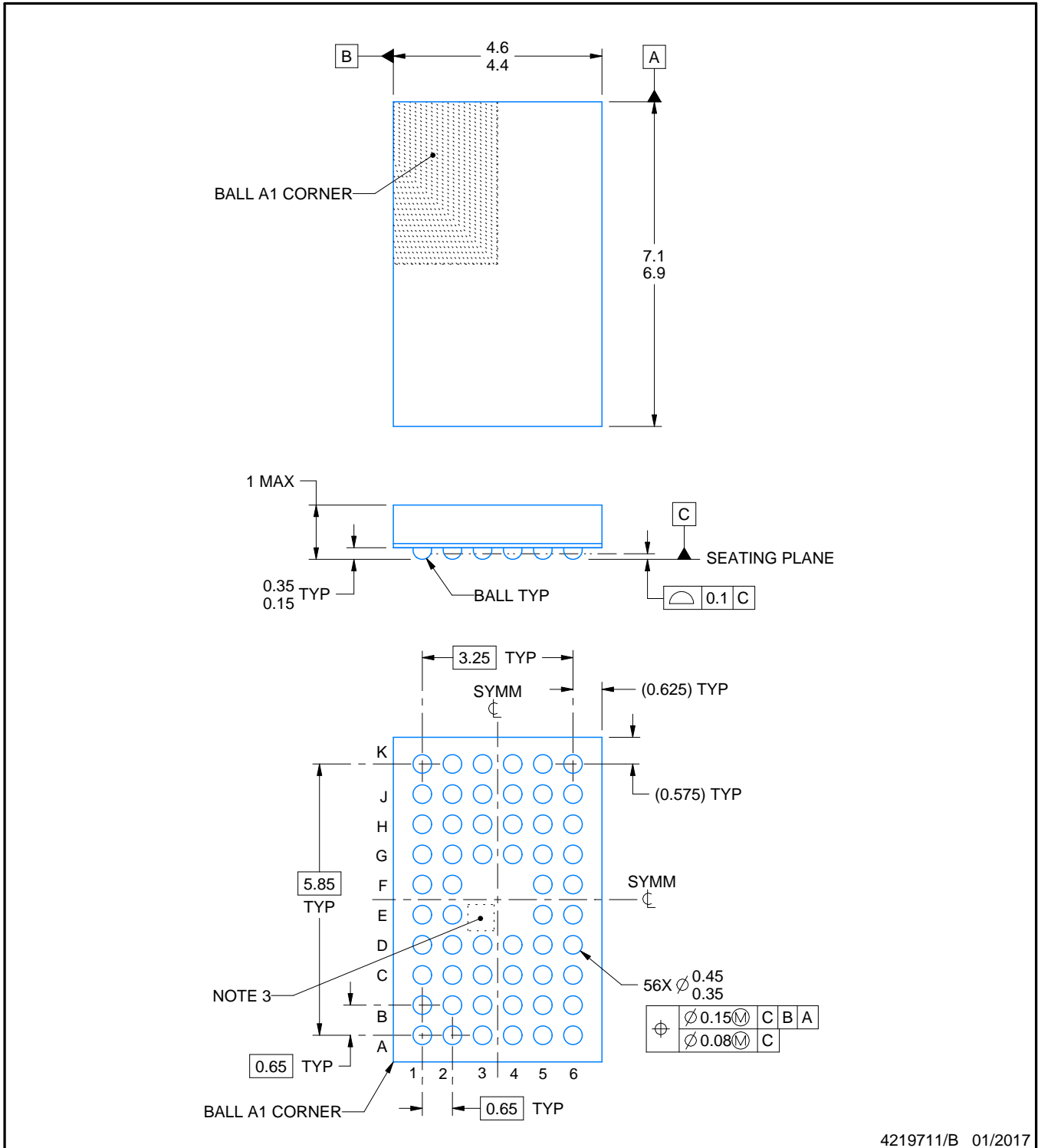
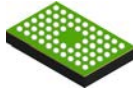

4219711/B 01/2017

NOTES:

1. All linear dimensions are in millimeters. Any dimensions in parenthesis are for reference only. Dimensioning and tolerancing per ASME Y14.5M.
2. This drawing is subject to change without notice.
3. No metal in this area, indicates orientation.

EXAMPLE BOARD LAYOUT

ZQL0056A

JRBGA - 1 mm max height

PLASTIC BALL GRID ARRAY

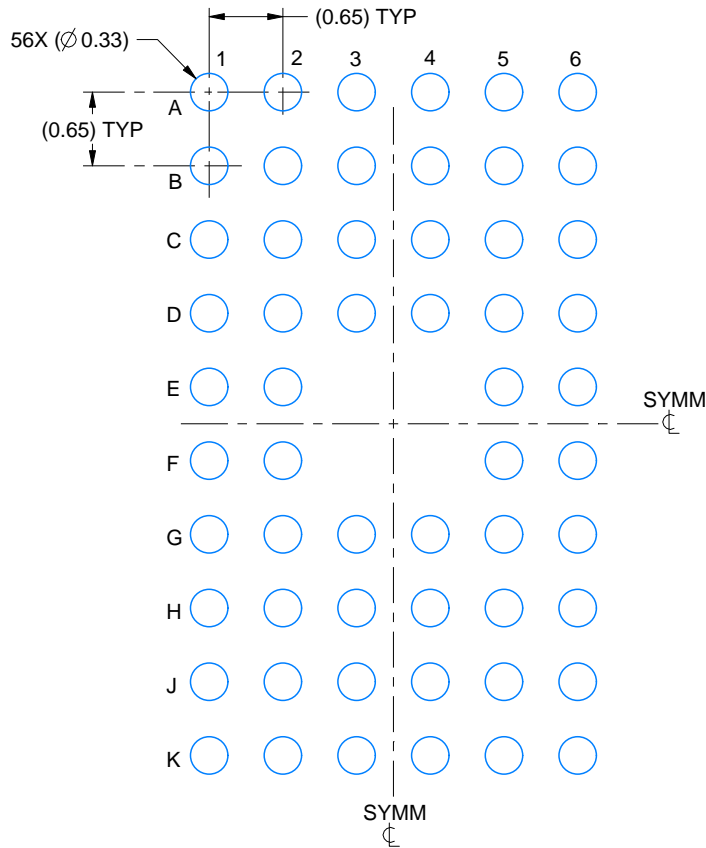

LAND PATTERN EXAMPLE
EXPOSED METAL SHOWN
SCALE:15X

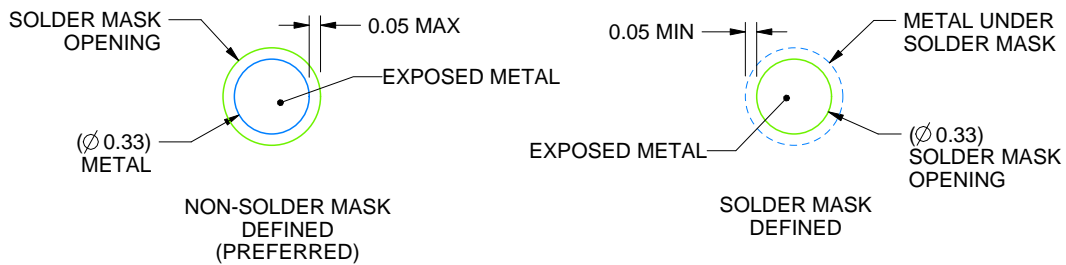

SOLDER MASK DETAILS
NOT TO SCALE

4219711/B 01/2017

NOTES: (continued)

- Final dimensions may vary due to manufacturing tolerance considerations and also routing constraints. For information, see Texas Instruments literature number SPRAA99 (www.ti.com/lit/spraa99).

EXAMPLE STENCIL DESIGN

ZQL0056A

JRBGA - 1 mm max height

PLASTIC BALL GRID ARRAY

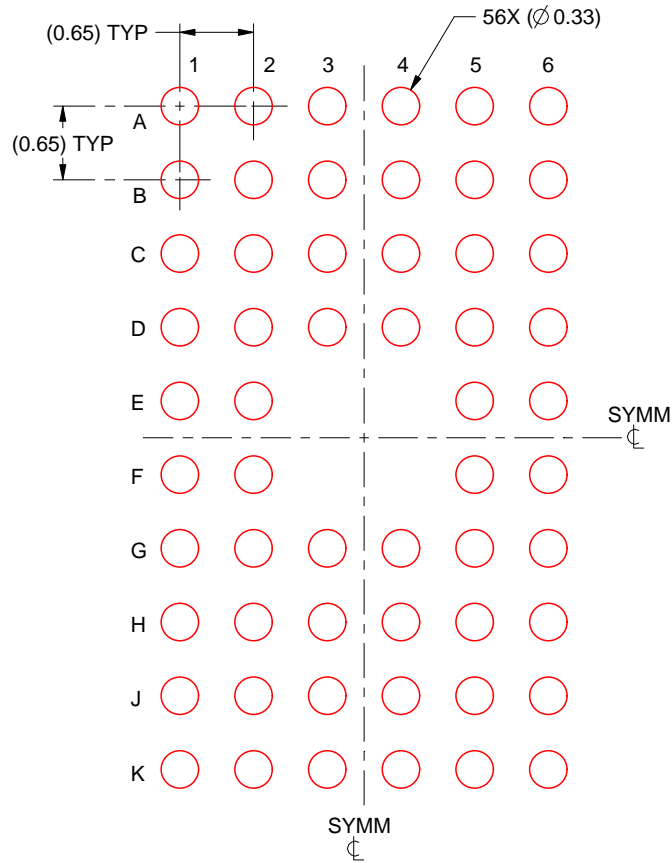

SOLDER PASTE EXAMPLE
BASED ON 0.125 mm THICK STENCIL
SCALE:15X

4219711/B 01/2017

NOTES: (continued)

5. Laser cutting apertures with trapezoidal walls and rounded corners may offer better paste release.

IMPORTANT NOTICE AND DISCLAIMER

TI PROVIDES TECHNICAL AND RELIABILITY DATA (INCLUDING DATASHEETS), DESIGN RESOURCES (INCLUDING REFERENCE DESIGNS), APPLICATION OR OTHER DESIGN ADVICE, WEB TOOLS, SAFETY INFORMATION, AND OTHER RESOURCES "AS IS" AND WITH ALL FAULTS, AND DISCLAIMS ALL WARRANTIES, EXPRESS AND IMPLIED, INCLUDING WITHOUT LIMITATION ANY IMPLIED WARRANTIES OF MERCHANTABILITY, FITNESS FOR A PARTICULAR PURPOSE OR NON-INFRINGEMENT OF THIRD PARTY INTELLECTUAL PROPERTY RIGHTS.

These resources are intended for skilled developers designing with TI products. You are solely responsible for (1) selecting the appropriate TI products for your application, (2) designing, validating and testing your application, and (3) ensuring your application meets applicable standards, and any other safety, security, or other requirements. These resources are subject to change without notice. TI grants you permission to use these resources only for development of an application that uses the TI products described in the resource. Other reproduction and display of these resources is prohibited. No license is granted to any other TI intellectual property right or to any third party intellectual property right. TI disclaims responsibility for, and you will fully indemnify TI and its representatives against, any claims, damages, costs, losses, and liabilities arising out of your use of these resources.

TI's products are provided subject to TI's Terms of Sale (www.ti.com/legal/termsofsale.html) or other applicable terms available either on ti.com or provided in conjunction with such TI products. TI's provision of these resources does not expand or otherwise alter TI's applicable warranties or warranty disclaimers for TI products.

Mailing Address: Texas Instruments, Post Office Box 655303, Dallas, Texas 75265
Copyright © 2019, Texas Instruments Incorporated

Looking for pricing, stock, or lifecycle information?

Click below to explore more details on WIN SOURCE:

 [View SN74LVC162244ADLR on WIN SOURCE](#)

 [Texas Instruments](#) Information

Optimize Your Supply Chain with WIN SOURCE Solutions

-  Global Sourcing Solution
-  Obsolete Management
-  Cost Control Management
-  Shortage Management
-  Alternative Solution
-  Excess Inventory Management