



**THE DATASHEET OF
DM74LS156N**



DM74LS155 • DM74LS156

Dual 2-Line to 4-Line Decoders/Demultiplexers

General Description

These TTL circuits feature dual 1-line-to-4-line demultiplexers with individual strobes and common binary-address inputs in a single 16-pin package. When both sections are enabled by the strobes, the common address inputs sequentially select and route associated input data to the appropriate output of each section. The individual strobes permit activating or inhibiting each of the 4-bit sections as desired. Data applied to input C1 is inverted at its outputs and data applied at C2 is true through its outputs. The inverter following the C1 data input permits use as a 3-to-8-line decoder, or 1-to-8-line demultiplexer, without external gating. Input clamping diodes are provided on these circuits to minimize transmission-line effects and simplify system design.

Features

- Applications:
 - Dual 2-to-4-line decoder
 - Dual 1-to-4-line demultiplexer
 - 3-to-8-line decoder
 - 1-to-8-line demultiplexer
- Individual strobes simplify cascading for decoding or demultiplexing larger words
- Input clamping diodes simplify system design
- Choice of outputs:
 - Totem-pole (DM74LS155)
 - Open-collector (DM74LS156)

Ordering Code:

Order Number	Package Number	Package Description
DM74LS155M	M16A	16-Lead Small Outline Integrated Circuit (SOIC), JEDEC MS-012, 0.150 Narrow
DM74LS155N	N16E	16-Lead Plastic Dual-In-Line Package (PDIP), JEDEC MS-001, 0.300 Wide
DM74LS156M	M16A	16-Lead Small Outline Integrated Circuit (SOIC), JEDEC MS-012, 0.150 Narrow
DM74LS156N	N16E	16-Lead Plastic Dual-In-Line Package (PDIP), JEDEC MS-001, 0.300 Wide

Devices also available in Tape and Reel. Specify by appending the suffix letter "X" to the ordering code.

Connection Diagram

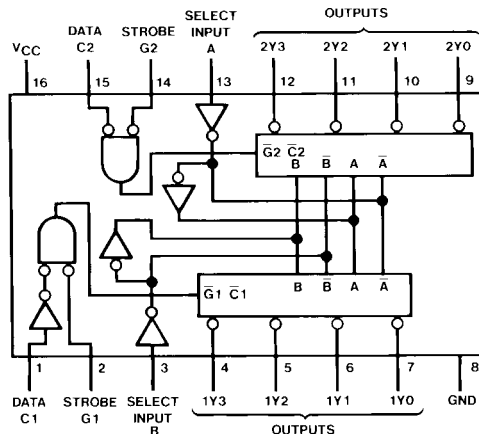

Function Tables

3-Line-to-8-Line Decoder or 1-Line-to-8-Line Demultiplexer

Inputs				Outputs							
Select			Strobe Or Data	(0)	(1)	(2)	(3)	(4)	(5)	(6)	(7)
C (Note 1)	B	A	G (Note 2)	2Y0	2Y1	2Y2	2Y3	1Y0	1Y1	1Y2	1Y3
X	X	X	H	H	H	H	H	H	H	H	H
L	L	L	L	L	H	H	H	H	H	H	H
L	L	H	L	H	L	H	H	H	H	H	H
L	H	L	L	H	H	L	H	H	H	H	H
L	H	H	L	H	H	H	L	H	H	H	H
H	L	L	L	H	H	H	H	L	H	H	H
H	L	H	L	H	H	H	H	H	L	H	H
H	H	L	L	H	H	H	H	H	H	L	H
H	H	H	L	H	H	H	H	H	H	H	L

2-Line-to-4-Line Decoder or 1-Line-to-4-Line Demultiplexer

Inputs				Outputs				Inputs				Outputs			
Select		Strobe	Data	1Y0	1Y1	1Y2	1Y3	Select		Strobe	Data	2Y0	2Y1	2Y2	2Y3
B	A	G1	C1					B	A	G2	C2				
X	X	H	X	H	H	H	H	X	X	H	X	H	H	H	H
L	L	L	H	L	H	H	H	L	L	L	L	L	H	H	H
L	H	L	H	H	L	H	H	L	H	L	L	H	L	H	H
H	L	L	H	H	H	L	H	H	L	L	L	H	H	L	H
H	H	L	H	H	H	H	L	H	H	L	L	H	H	H	L
X	X	X	L	H	H	H	H	X	X	X	H	H	H	H	H

H = HIGH level
L = LOW level
X = don't care

Note 1: C = inputs C1 and C2 connected together

Note 2: G = inputs G1 and G2 connected together

Logic Diagram

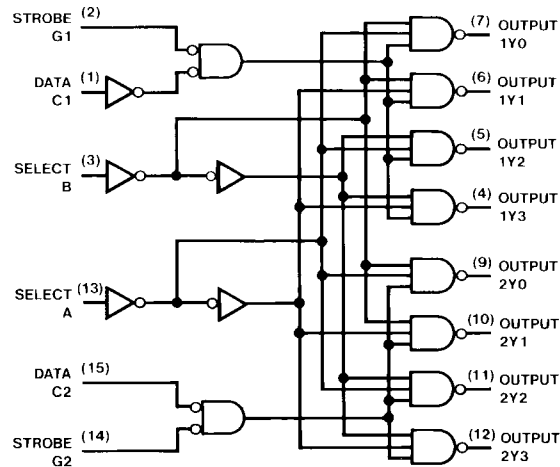

Absolute Maximum Ratings(Note 3)

Supply Voltage	7V
Input Voltage	7V
Operating Free Air Temperature Range	0°C to +70°C
Storage Temperature Range	-65°C to +150°C

Note 3: The "Absolute Maximum Ratings" are those values beyond which the safety of the device cannot be guaranteed. The device should not be operated at these limits. The parametric values defined in the Electrical Characteristics tables are not guaranteed at the absolute maximum ratings. The "Recommended Operating Conditions" table will define the conditions for actual device operation.

DM74LS155 Recommended Operating Conditions

Symbol	Parameter	Min	Nom	Max	Units
V _{CC}	Supply Voltage	4.75	5	5.25	V
V _{IH}	HIGH Level Input Voltage	2			V
V _{IL}	LOW Level Input Voltage			0.8	V
V _{OH}	HIGH Level Output Current			-0.4	mA
I _{OL}	LOW Level Output Current			8	mA
T _A	Free Air Operating Temperature	0		70	°C

DM74LS155 Electrical Characteristics

over recommended operating free air temperature range (unless otherwise noted)

Symbol	Parameter	Conditions	Min	Typ (Note 4)	Max	Units
V _I	Input Clamp Voltage	V _{CC} = Min, I _I = -18 mA			-1.5	V
V _{OH}	HIGH Level Output Voltage	V _{CC} = Min, I _{OH} = Max V _{IL} = Max, V _{IH} = Min	2.7	3.4		V
V _{OL}	LOW Level Output Voltage	V _{CC} = Min, I _{OL} = Max V _{IL} = Max, V _{IH} = Min I _{OL} = 4 mA, V _{CC} = Min		0.35 0.25	0.5 0.4	V
I _I	Input Current @ Max Input Voltage	V _{CC} = Max, V _I = 7V			0.1	mA
I _{IH}	HIGH Level Input Current	V _{CC} = Max, V _I = 2.7V			20	μA
I _{IL}	LOW Level Input Current	V _{CC} = Max, V _I = 0.4V			-0.36	mA
I _{OS}	Short Circuit Output Current	V _{CC} = Max (Note 5)	-20		-100	mA
I _{CC}	Supply Current	V _{CC} = Max (Note 6)		6.1	10	mA

Note 4: All typicals are at V_{CC} = 5V, T_A = 25° C.

Note 5: Not more than one output should be shorted at a time, and the duration should not exceed one second.

Note 6: I_{CC} is measured with all outputs OPEN, A,B, and C1 inputs at 4.5V, and C2, G1, and G2 inputs GROUNDED.

DM74LS155 Switching Characteristics

at V_{CC} = 5V and T_A = 25°C

Symbol	Parameter	From (Input) To (Output)	R _L = 2 kΩ				Units
			C _L = 15 pF		C _L = 50 pF		
			Min	Max	Min	Max	
t _{PLH}	Propagation Delay Time LOW-to-HIGH Level Output	A, B, C2, G1 or G2 to Y		18		22	ns
t _{PHL}	Propagation Delay Time HIGH-to-LOW Level Output	A, B, C2, G1 or G2 to Y		27		35	ns
t _{PLH}	Propagation Delay Time LOW-to-HIGH Level Output	A or B to Y		18		24	ns
t _{PHL}	Propagation Delay Time HIGH-to-LOW Level Output	A or B to Y		27		35	ns
t _{PLH}	Propagation Delay Time LOW-to-HIGH Level Output	C1 to Y		20		24	ns
t _{PHL}	Propagation Delay Time HIGH-to-LOW Level Output	C1 to Y		27		35	ns

DM74LS156 Recommended Operating Conditions

Symbol	Parameter	Min	Nom	Max	Units
V_{CC}	Supply Voltage	4.75	5	5.25	V
V_{IH}	HIGH Level Input Voltage	2			V
V_{IL}	LOW Level Input Voltage			0.8	V
V_{OH}	HIGH Level Output Voltage			5.5	V
I_{OL}	LOW Level Output Current			8	mA
T_A	Free Air Operating Temperature	0		70	°C

DM74LS156 Electrical Characteristics

over recommended operating free air temperature range (unless otherwise noted)

Symbol	Parameter	Conditions	Min	Typ (Note 7)	Max	Units
V_I	Input Clamp Voltage	$V_{CC} = \text{Min}, I_I = -18 \text{ mA}$			-1.5	V
I_{CEX}	HIGH Level Output Current	$V_{CC} = \text{Min}, V_O = 5.5 \text{ V}$ $V_{IL} = \text{Max}, V_{IH} = \text{Min}$			100	μA
V_{OL}	LOW Level Output Voltage	$V_{CC} = \text{Min}, I_{OL} = \text{Max}$ $V_{IL} = \text{Max}, V_{IH} = \text{Min}$ $I_{OL} = 4 \text{ mA}, V_{CC} = \text{Min}$		0.35	0.5	V
I_I	Input Current @ Max Input Voltage	$V_{CC} = \text{Max}, V_I = 7 \text{ V}$			0.1	mA
I_{IH}	HIGH Level Input Current	$V_{CC} = \text{Max}, V_I = 2.7 \text{ V}$			20	μA
I_{IL}	LOW Level Input Current	$V_{CC} = \text{Max}, V_I = 0.4 \text{ V}$			-0.36	mA
I_{CC}	Supply Current	$V_{CC} = \text{Max}$ (Note 8)		6.1	10	mA

Note 7: All typicals are at $V_{CC} = 5 \text{ V}, T_A = 25^\circ \text{ C}$.

Note 8: I_{CC} is measured with all outputs OPEN, A, B, and C1 inputs at 4.5V, and C2, G1, and G2 GROUNDED.

DM74LS156 Switching Characteristics

at $V_{CC} = 5 \text{ V}$ and $T_A = 25^\circ \text{ C}$

Symbol	Parameter	From (Input) To (Output)	$R_L = 2 \text{ k}\Omega$				Units
			$C_L = 15 \text{ pF}$		$C_L = 50 \text{ pF}$		
			Min	Max	Min	Max	
t_{PLH}	Propagation Delay Time LOW-to-HIGH Level Output	A, B, C2, G1 or G2 to Y		28		53	ns
t_{PHL}	Propagation Delay Time HIGH-to-LOW Level Output	A, B, C2, G1 or G2 to Y		33		43	ns
t_{PLH}	Propagation Delay Time LOW-to-HIGH Level Output	A or B to Y		28		53	ns
t_{PHL}	Propagation Delay Time HIGH-to-LOW Level Output	A or B to Y		33		43	ns
t_{PLH}	Propagation Delay Time LOW-to-HIGH Level Output	C1 to Y		28		53	ns
t_{PHL}	Propagation Delay Time HIGH-to-LOW Level Output	C1 to Y		34		43	ns

Physical Dimensions inches (millimeters) unless otherwise noted

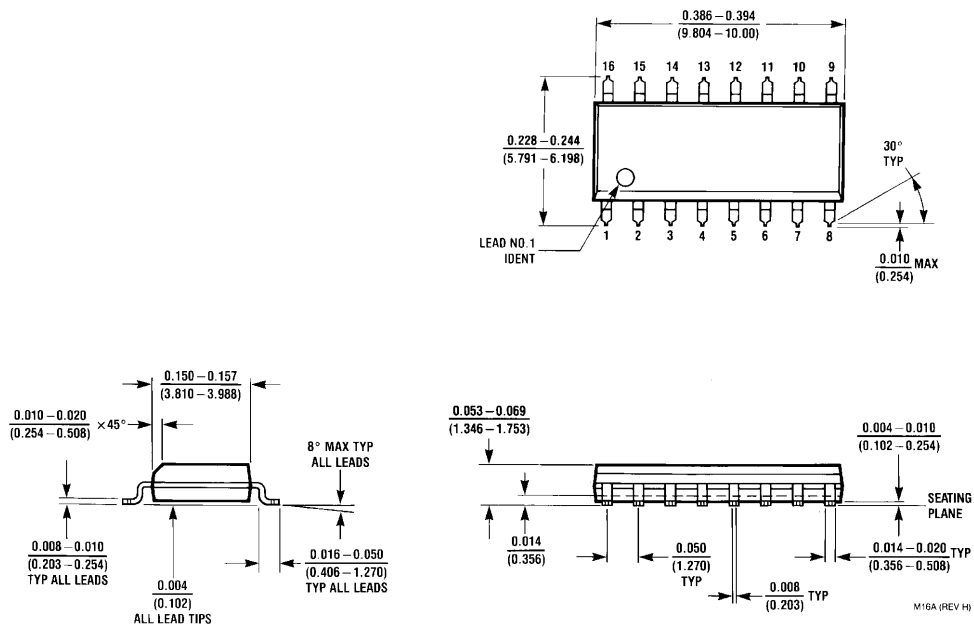

**16-Lead Small Outline Integrated Circuit (SOIC), JEDEC MS-012, 0.150 Narrow
Package Number M16A**

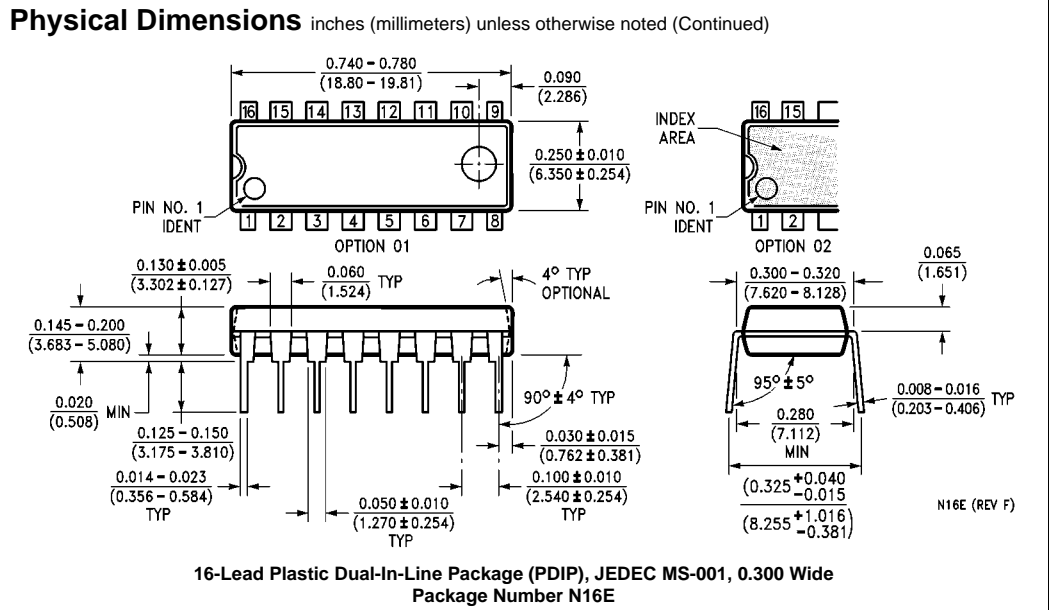

Fairchild does not assume any responsibility for use of any circuitry described, no circuit patent licenses are implied and Fairchild reserves the right at any time without notice to change said circuitry and specifications.

LIFE SUPPORT POLICY

FAIRCHILD'S PRODUCTS ARE NOT AUTHORIZED FOR USE AS CRITICAL COMPONENTS IN LIFE SUPPORT DEVICES OR SYSTEMS WITHOUT THE EXPRESS WRITTEN APPROVAL OF THE PRESIDENT OF FAIRCHILD SEMICONDUCTOR CORPORATION. As used herein:

1. Life support devices or systems are devices or systems which, (a) are intended for surgical implant into the body, or (b) support or sustain life, and (c) whose failure to perform when properly used in accordance with instructions for use provided in the labeling, can be reasonably expected to result in a significant injury to the user.
2. A critical component in any component of a life support device or system whose failure to perform can be reasonably expected to cause the failure of the life support device or system, or to affect its safety or effectiveness.

www.fairchildsemi.com

Looking for pricing, stock, or lifecycle information?

Click below to explore more details on WIN SOURCE:

- ⊖ [View DM74LS156N](#) on WIN SOURCE
- ⊖ [ON Semiconductor](#) Information

Optimize Your Supply Chain with WIN SOURCE Solutions

- ✓ Global Sourcing Solution
- ✓ Obsolete Management
- ✓ Cost Control Management
- ✓ Shortage Management
- ✓ Alternative Solution
- ✓ Excess Inventory Management