

TIBPAL16L8-5C, TIBPAL16R4-5C, TIBPAL16R6-5C, TIBPAL16R8-5C
 TIBPAL16L8-7M, TIBPAL16R4-7M, TIBPAL16R6-7M, TIBPAL16R8-7M
 HIGH-PERFORMANCE *IMPACT-X*TM PAL[®] CIRCUITS

SRPS011D – D3359, OCTOBER 1989 – REVISED SEPTEMBER 1992

- **High-Performance Operation:**
 - f_{max} (no feedback)
 - TIBPAL16R' -5C Series . . . 125 MHz Min
 - TIBPAL16R' -7M Series . . . 100 MHz Min
 - f_{max} (internal feedback)
 - TIBPAL16R' -5C Series . . . 125 MHz Min
 - TIBPAL16R' -7M Series . . . 100 MHz Min
 - f_{max} (external feedback)
 - TIBPAL16R' -5C Series . . . 117 MHz Min
 - TIBPAL16R' -7M Series . . . 74 MHz Min
 - Propagation Delay**
 - TIBPAL16L8-5C Series . . . 5 ns Max
 - TIBPAL16L8-7M Series . . . 7 ns Max
 - TIBPAL16R' -5C Series (CLK-to-Q) . . . 4 ns Max
 - TIBPAL16R' -7M Series (CLK-to-Q) . . . 6.5 ns Max

- **Functionally Equivalent, but Faster than, Existing 20-Pin PLDs**
- **Preload Capability on Output Registers Simplifies Testing**
- **Power-Up Clear on Registered Devices (All Register Outputs are Set Low, but Voltage Levels at the Output Pins Go High)**
- **Package Options Include Both Plastic and Ceramic Chip Carriers in Addition to Plastic and Ceramic DIPs**
- **Security Fuse Prevents Duplication**

DEVICE	I INPUTS	3-STATE O OUTPUTS	REGISTERED Q OUTPUTS	I/O PORTS
'PAL16L8	10	2	0	6
'PAL16R4	8	0	4 (3-state buffers)	4
'PAL16R6	8	0	6 (3-state buffers)	2
'PAL16R8	8	0	8 (3-state buffers)	0

TIBPAL16L8'
 C SUFFIX . . . J OR N PACKAGE
 M SUFFIX . . . J PACKAGE

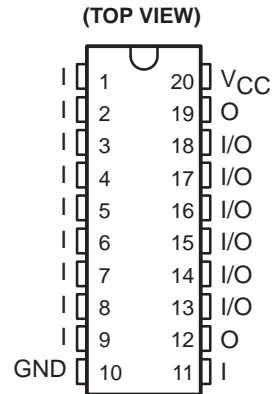

TIBPAL16L8'
 C SUFFIX . . . FN PACKAGE
 M SUFFIX . . . FK PACKAGE

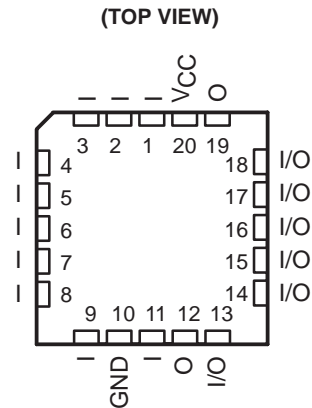

Pin assignments in operating mode

description

These programmable array logic devices feature high speed and functional equivalency when compared with currently available devices. These *IMPACT-X*TM circuits combine the latest Advanced Low-Power Schottky technology with proven titanium-tungsten fuses to provide reliable, high-performance substitutes for conventional TTL logic. Their easy programmability allows for quick design of custom functions and typically results in a more compact circuit board.

The TIBPAL16' C series is characterized from 0°C to 75°C. The TIBPAL16' M series is characterized for operation over the full military temperature range of -55°C to 125°C.

These devices are covered by U.S. Patent 4,410,987.
IMPACT-X is a trademark of Texas Instruments Incorporated.
 PAL is a registered trademark of Advanced Micro Devices Inc.

This document contains information on products in more than one phase of development. The status of each device is indicated on the page(s) specifying its electrical characteristics.



**TIBPAL16R4-5C, TIBPAL16R6-5C, TIBPAL16R8-5C
TIBPAL16R4-7M, TIBPAL16R6-7M, TIBPAL16R8-7M
HIGH-PERFORMANCE *IMPACT-X*[™] PAL[®] CIRCUITS**
SRPS011D – D3359, OCTOBER 1989 – REVISED SEPTEMBER 1992

TIBPAL16R4'
C SUFFIX . . . J OR N PACKAGE
M SUFFIX . . . J PACKAGE

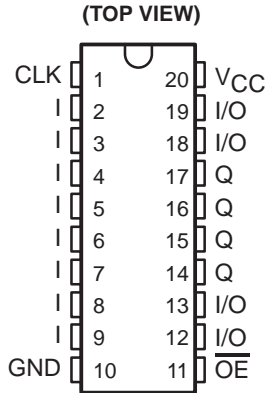

TIBPAL16R4'
C SUFFIX . . . FN PACKAGE
M SUFFIX . . . FK PACKAGE

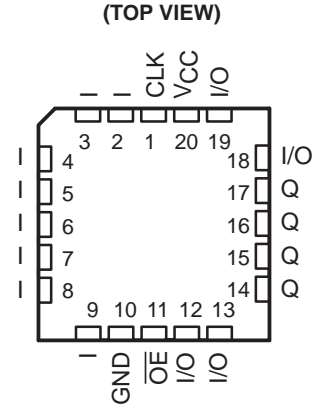

TIBPAL16R6'
C SUFFIX . . . J OR N PACKAGE
M SUFFIX . . . J PACKAGE

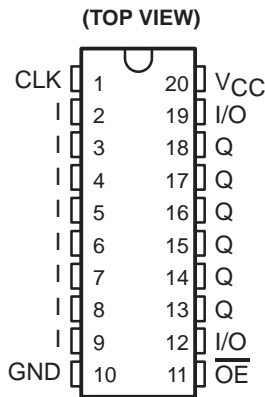

TIBPAL16R6'
C SUFFIX . . . FN PACKAGE
M SUFFIX . . . FK PACKAGE

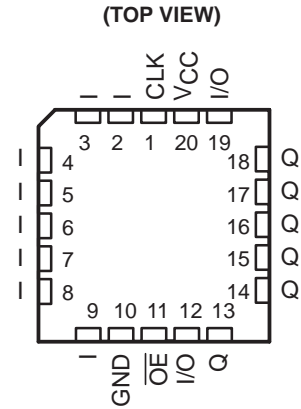

TIBPAL16R8'
C SUFFIX . . . J OR N PACKAGE
M SUFFIX . . . J PACKAGE

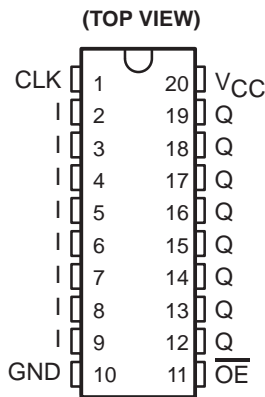

TIBPAL16R8'
C SUFFIX . . . FN PACKAGE
M SUFFIX . . . FK PACKAGE

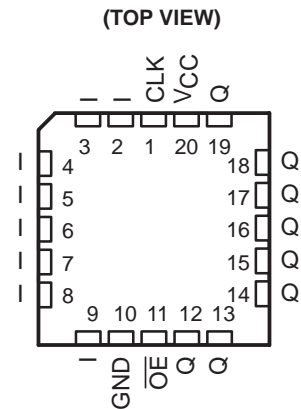

Pin assignments in operating mode

functional block diagrams (positive logic)

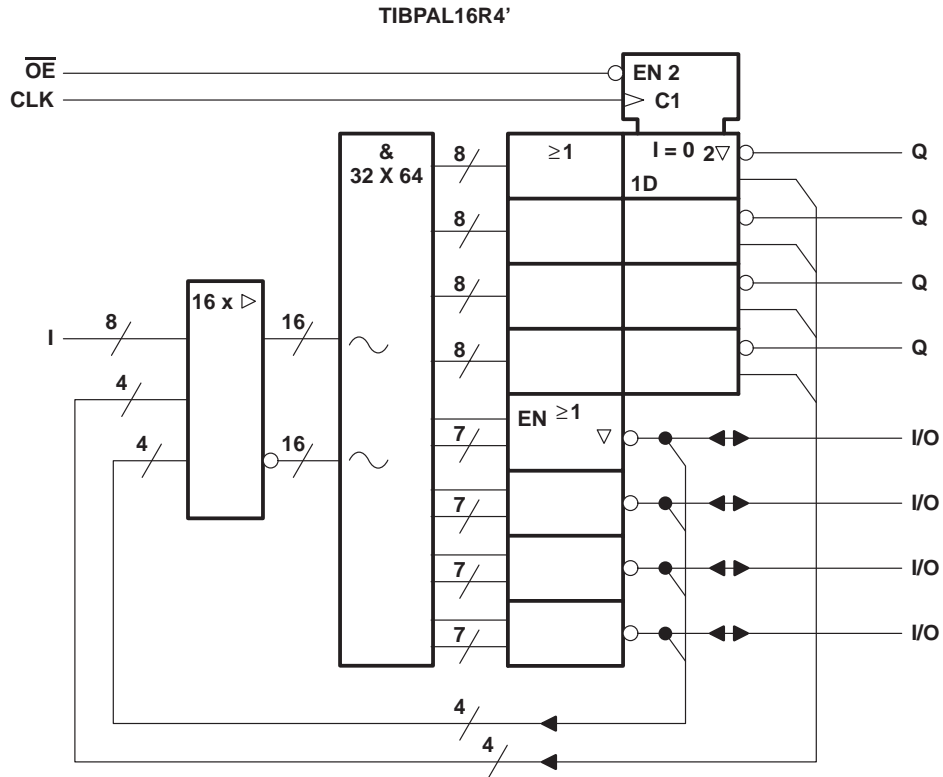
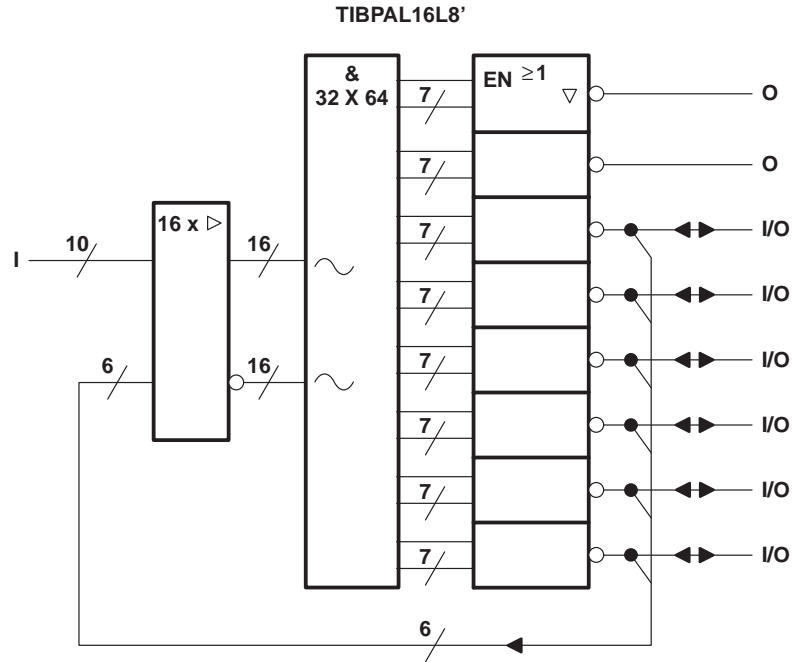

~ denotes fused inputs

functional block diagrams (positive logic)

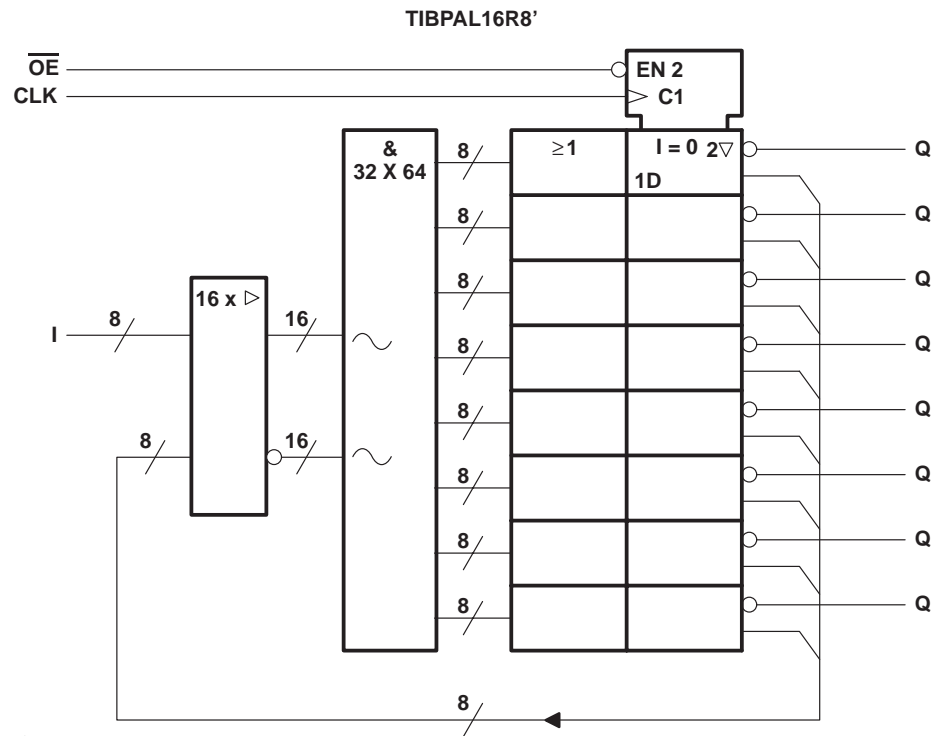
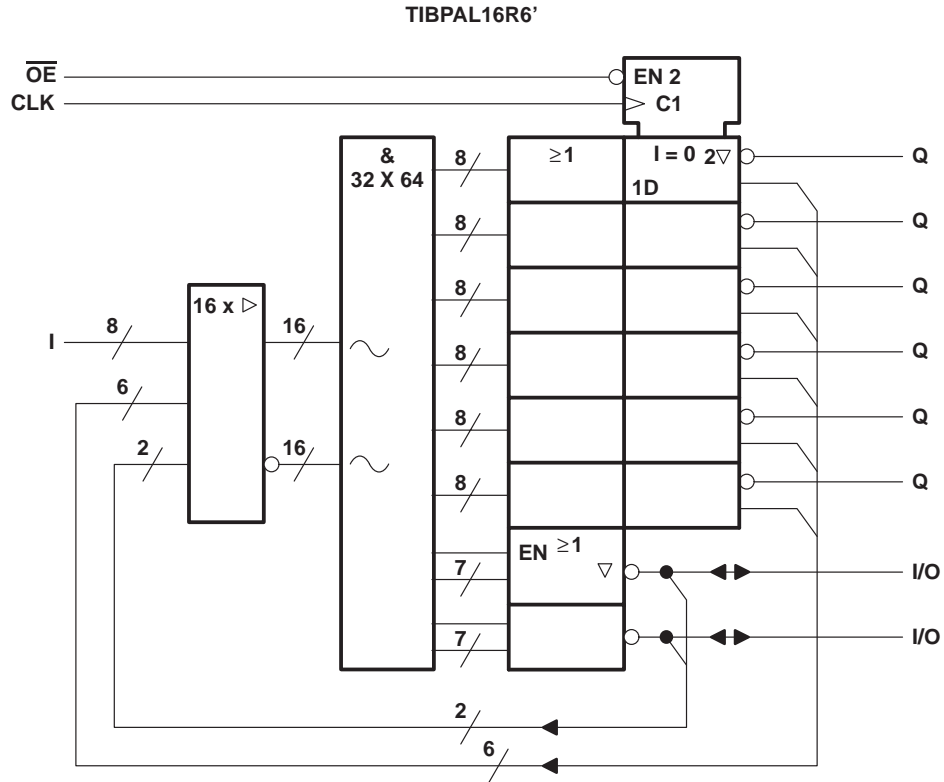

~ denotes fused inputs

logic diagram (positive logic)

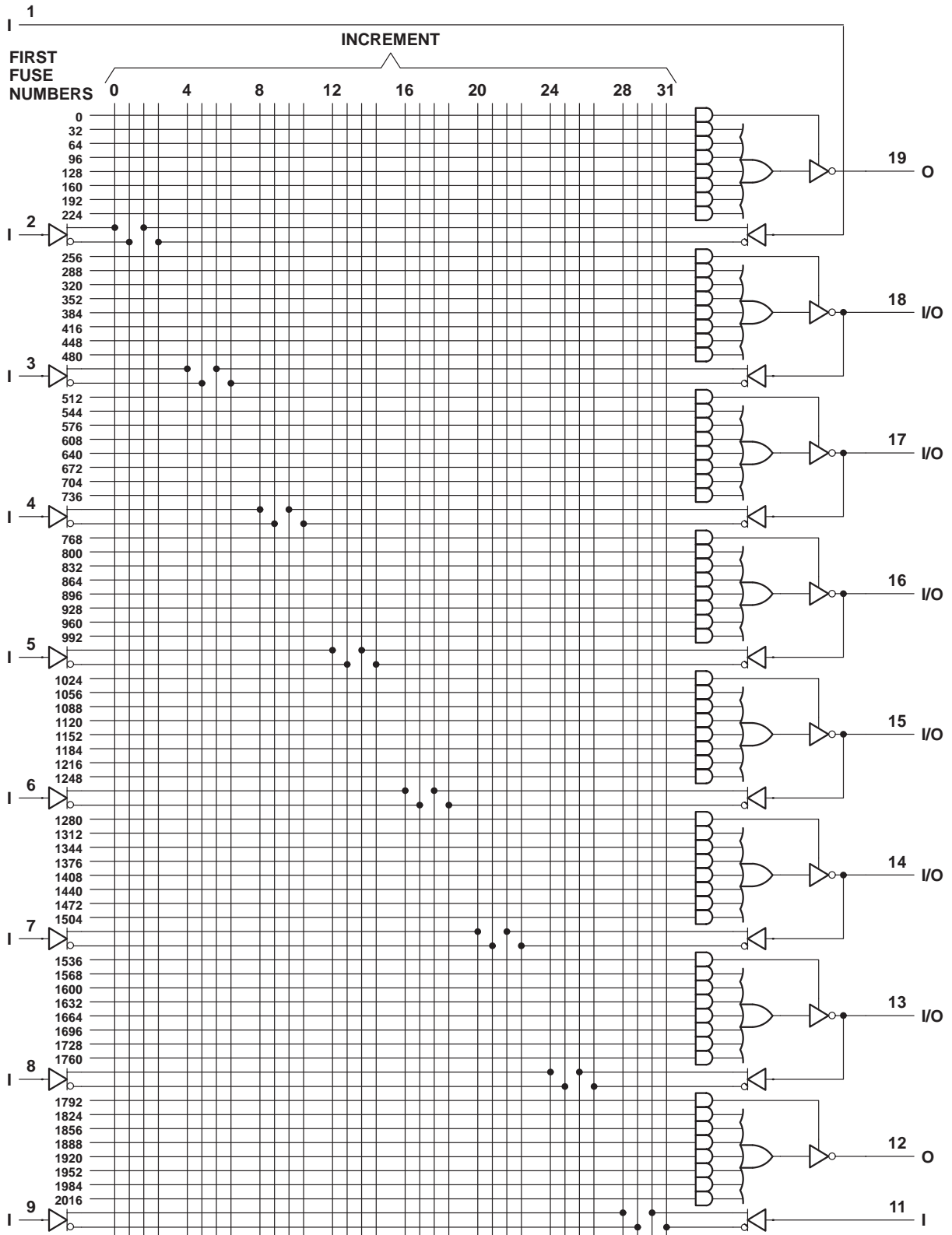

Fuse number = First fuse number + Increment

logic diagram (positive logic)

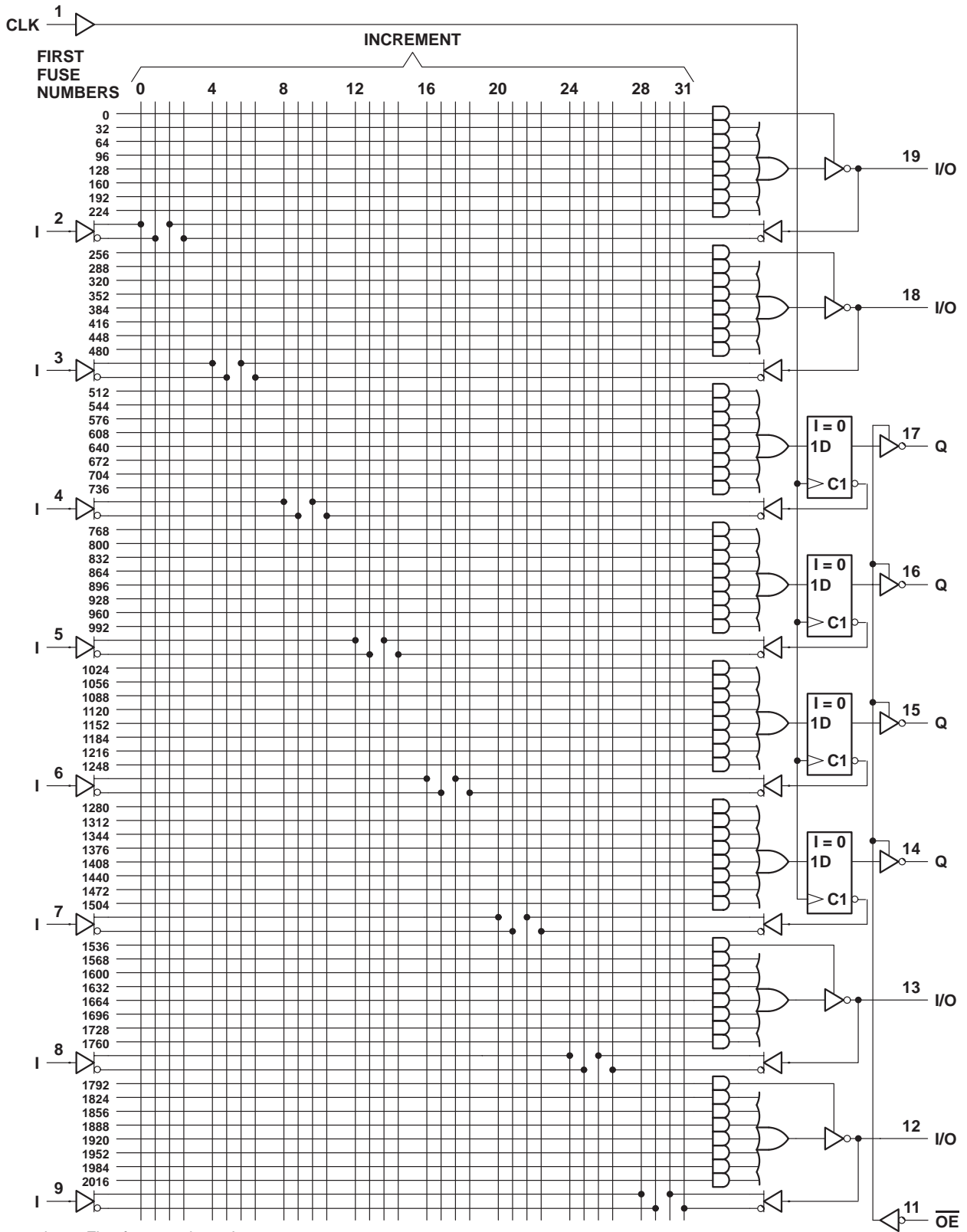

Fuse number = First fuse number + Increment



logic diagram (positive logic)

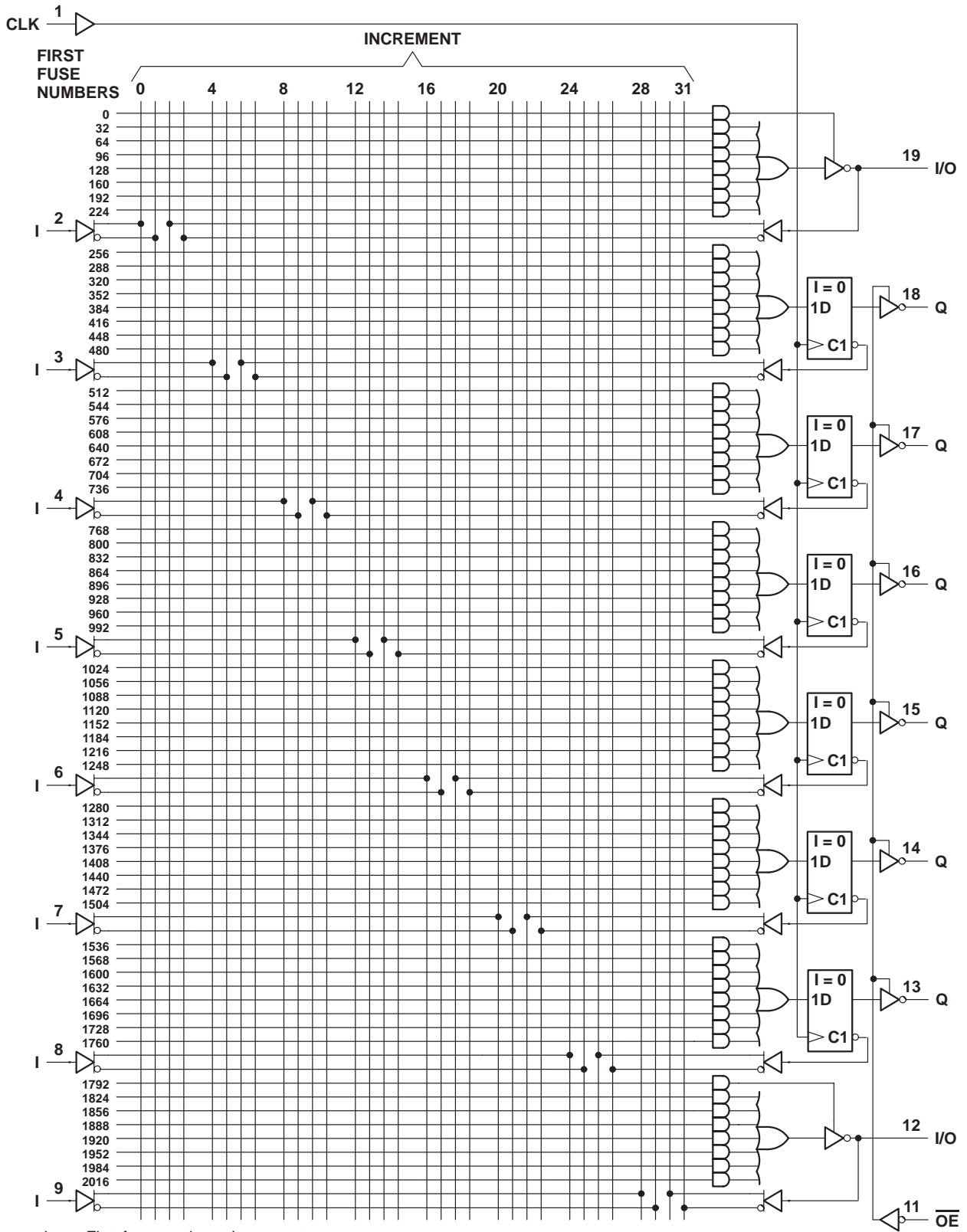

Fuse number = First fuse number + Increment



logic diagram (positive logic)

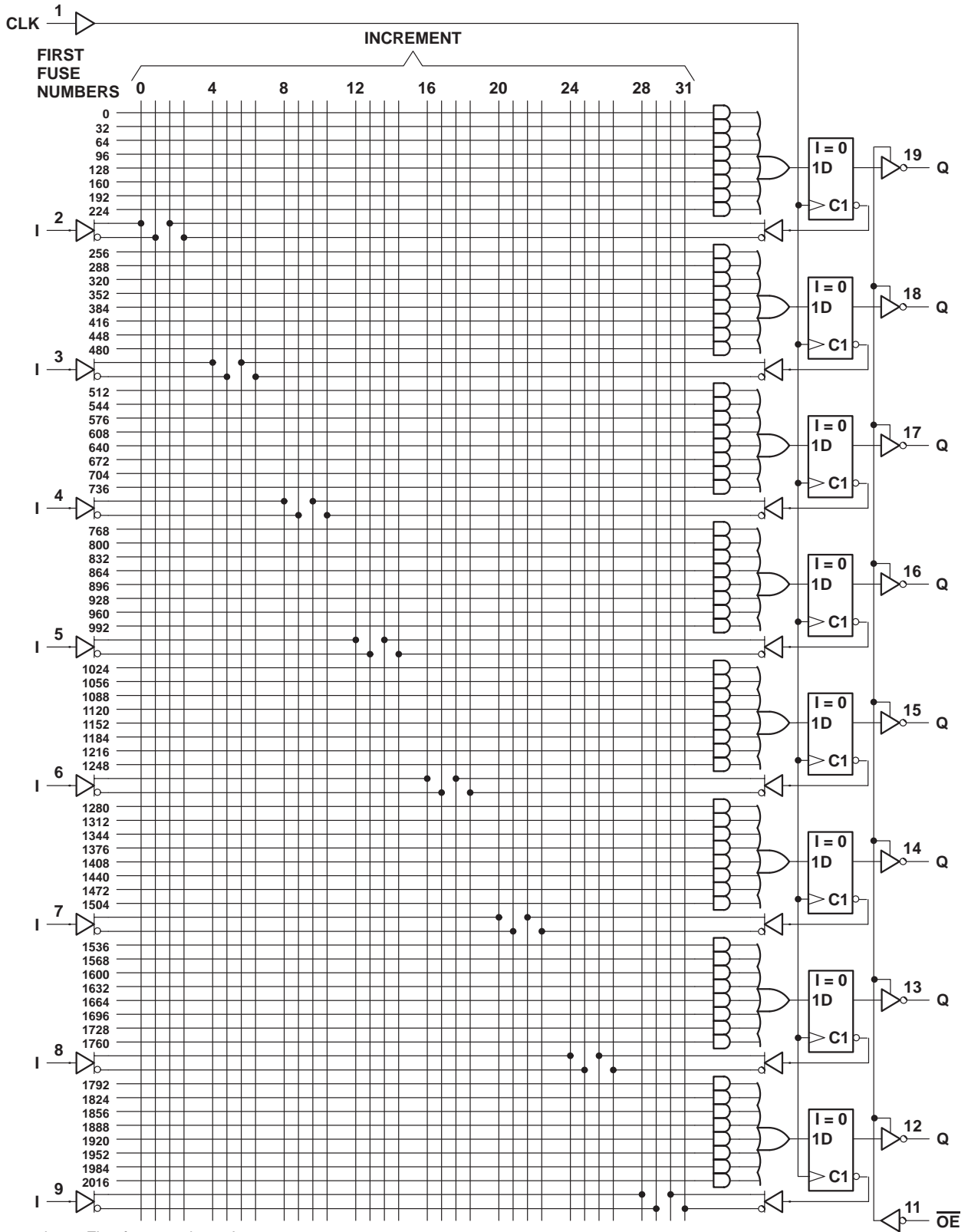

Fuse number = First fuse number + Increment



absolute maximum ratings over operating free-air temperature range (unless otherwise noted)

Supply voltage, V_{CC} (see Note 1)	7 V
Input voltage (see Note 1)	5.5 V
Voltage applied to disabled output (see Note 1)	5.5 V
Operating free-air temperature range	0°C to 75°C
Storage temperature range	–65°C to 150°C

NOTE 1: These ratings apply except for programming pins during a programming cycle or during a preload cycle.

recommended operating conditions

		MIN	NOM	MAX	UNIT
V_{CC}	Supply voltage	4.75	5	5.25	V
V_{IH}	High-level input voltage (see Note 2)	2		5.5	V
V_{IL}	Low-level input voltage (see Note 2)			0.8	V
I_{OH}	High-level output current			–3.2	mA
I_{OL}	Low-level output current			24	mA
T_A	Operating free-air temperature	0	25	75	°C

NOTE 2: These are absolute voltage levels with respect to the ground pin of the device and include all overshoots due to system and/or tester noise. Testing these parameters should not be attempted without suitable equipment.

electrical characteristics over recommended operating free-air temperature range

PARAMETER	TEST CONDITIONS		MIN	TYP†	MAX	UNIT
V_{IK}	$V_{CC} = 4.75$ V,	$I_I = -18$ mA		–0.8	–1.5	V
V_{OH}	$V_{CC} = 4.75$ V,	$I_{OH} = -3.2$ mA	2.4	2.7		V
V_{OL}	$V_{CC} = 4.75$ V,	$I_{OL} = 24$ mA		0.3	0.5	V
$I_{OZH}‡$	$V_{CC} = 5.25$ V,	$V_O = 2.7$ V			100	μA
$I_{OZL}‡$	$V_{CC} = 5.25$ V,	$V_O = 0.4$ V			–100	μA
I_I	$V_{CC} = 5.25$ V,	$V_I = 5.5$ V			100	μA
$I_{IH}‡$	$V_{CC} = 5.25$ V,	$V_I = 2.7$ V			25	μA
$I_{IL}‡$	$V_{CC} = 5.25$ V,	$V_I = 0.4$ V			–250	μA
$I_{OS}§$	$V_{CC} = 5.25$ V,	$V_O = 0.5$ V	–30	–70	–130	mA
I_{CC}	$V_{CC} = 5.25$ V,	$V_I = 0$, Outputs open			180	mA
C_i	$f = 1$ MHz,	$V_I = 2$ V		8.5		pF
C_o	$f = 1$ MHz,	$V_O = 2$ V		10		pF

† All typical values are at $V_{CC} = 5$ V, $T_A = 25^\circ\text{C}$.

‡ I/O leakage is the worst case of I_{OZL} and I_{IL} or I_{OZH} and I_{IH} , respectively.

§ Not more than one output should be shorted at a time, and the duration of the short circuit should not exceed one second. V_O is set at 0.5 V to avoid test problems caused by test equipment ground degradation.

switching characteristics over recommended ranges of supply voltage and operating free-air temperature (unless otherwise noted)

PARAMETER	FROM (INPUT)	TO (OUTPUT)	TEST CONDITIONS	TIBPAL16L8-5CFN		TIBPAL16L8-5CJ TIBPAL16L8-5CN		UNIT
				MIN	MAX	MIN	MAX	
t_{pd}	I, I/O	O, I/O with up to 4 outputs switching	R1 = 200 Ω, R2 = 200 Ω, See Figure 8	1.5	5	1.5	5	ns
	I, I/O	O, I/O with more than 4 outputs switching		1.5	5	1.5	5.5	
t_{en}	I, I/O	O, I/O		2	7	2	7	ns
t_{dis}	I, I/O	O, I/O		2	7	2	7	ns

PRODUCTION DATA information is current as of publication date. Products conform to specifications per the terms of Texas Instruments standard warranty. Production processing does not necessarily include testing of all parameters.



TIBPAL16R4-5C, TIBPAL16R6-5C HIGH-PERFORMANCE *IMPACT-X*™ PAL® CIRCUITS

SRPS011D – D3359, OCTOBER 1989 – REVISED SEPTEMBER 1992

absolute maximum ratings over operating free-air temperature range (unless otherwise noted)

Supply voltage, V_{CC} (see Note 1)	7 V
Input voltage (see Note 1)	5.5 V
Voltage applied to disabled output (see Note 1)	5.5 V
Operating free-air temperature range	0°C to 75°C
Storage temperature range	–65°C to 150°C

NOTE 1: These ratings apply except for programming pins during a programming cycle or during a preload cycle.

recommended operating conditions

		MIN	NOM	MAX	UNIT
V_{CC}	Supply voltage	4.75	5	5.25	V
V_{IH}	High-level input voltage (see Note 2)	2		5.5	V
V_{IL}	Low-level input voltage (see Note 2)			0.8	V
I_{OH}	High-level output current			–3.2	mA
I_{OL}	Low-level output current			24	mA
f_{clock}	Clock frequency	0		125	MHz
t_w	Pulse duration, clock	High	4		ns
		Low	4		
t_{su}	Setup time, input or feedback before clock↑	4.5		ns	
t_h	Hold time, input or feedback after clock↑	0		ns	
T_A	Operating free-air temperature	0	25	75	°C

NOTE 2: These are absolute voltage levels with respect to the ground pin of the device and include all overshoots due to system and/or tester noise. Testing these parameters should not be attempted without suitable equipment.

TIBPAL16R4-5C, TIBPAL16R6-5C
HIGH-PERFORMANCE *IMPACT-X*™ PAL® CIRCUITS

SRPS011D – D3359, OCTOBER 1989 – REVISED SEPTEMBER 1992

electrical characteristics over recommended operating free-air temperature range

PARAMETER		TEST CONDITIONS		MIN	TYP†	MAX	UNIT
V _{IK}		V _{CC} = 4.75 V,	I _I = -18 mA		-0.8	-1.5	V
V _{OH}		V _{CC} = 4.75 V,	I _{OH} = -3.2 mA	2.4	2.7		V
V _{OL}		V _{CC} = 4.75 V,	I _{OL} = 24 mA		0.3	0.5	V
I _{OZH} ‡		V _{CC} = 5.25 V,	V _O = 2.7 V			100	μA
I _{OZL} ‡		V _{CC} = 5.25 V,	V _O = 0.4 V			-100	μA
I _I		V _{CC} = 5.25 V,	V _I = 5.5 V			100	μA
I _{IH} ‡		V _{CC} = 5.25 V,	V _I = 2.7 V			25	μA
I _{IL} ‡		V _{CC} = 5.25 V,	V _I = 0.4 V			-250	μA
I _{OS} §		V _{CC} = 5.25 V,	V _O = 0.5 V	-30	-70	-130	mA
I _{CC}		V _{CC} = 5.25 V,	V _I = 0, Outputs open			200	mA
C _i	I	f = 1 MHz,	V _I = 2 V				pF
	CLK/OE			7			
C _o	I/O	f = 1 MHz,	V _O = 2 V				pF
	Q			10			
				5			
				7			

switching characteristics over recommended ranges of supply voltage and operating free-air temperature (unless otherwise noted)

PARAMETER	FROM (INPUT)	TO (OUTPUT)	TEST CONDITIONS	TIBPAL16R4-5CFN TIBPAL16R6-5CFN			TIBPAL16R4-5CJ TIBPAL16R6-5CJ TIBPAL16R4-5CN TIBPAL16R6-5CN			UNIT
				MIN	TYP†	MAX	MIN	TYP†	MAX	
f _{max} ¶	without feedback		R1 = 200 Ω, R2 = 200 Ω, See Figure 8	125			125			MHz
	with internal feedback (counter configuration)			125			125			
	with external feedback			117			111			
t _{pd}	CLK↑	Q		1.5			4			ns
t _{pd}	CLK↑	Internal feedback					3.5			ns
t _{pd}	I, I/O	I/O		1.5			5			ns
t _{en}	\overline{OE} ↓	Q		1.5			6			ns
t _{dis}	\overline{OE} ↑	Q		1			6.5			ns
t _{en}	I, I/O	I/O		2			7			ns
t _{dis}	I, I/O	I/O		2			7			ns
t _r			1.5			1.5			ns	
t _f			1.5			1.5			ns	
t _{sk(o)} #	Skew between registered outputs		0.5			0.5			ns	

† All typical values are at V_{CC} = 5 V, T_A = 25°C.

‡ I/O leakage is the worst case of I_{OZL} and I_{IL} or I_{OZH} and I_{IH}, respectively.

§ Not more than one output should be shorted at a time, and the duration of the short circuit should not exceed one second. V_O is set at 0.5 V to avoid test problems caused by test equipment ground degradation.

¶ See 'f_{max} Specification' near the end of this data sheet.

t_{sk(o)} is the skew time between registered outputs.

TIBPAL16R8-5C

HIGH-PERFORMANCE *IMPACT-X*™ *PAL*® CIRCUITS

SRPS011D – D3359, OCTOBER 1989 – REVISED SEPTEMBER 1992

absolute maximum ratings over operating free-air temperature range (unless otherwise noted)

Supply voltage, V_{CC} (see Note 1)	7 V
Input voltage (see Note 1)	5.5 V
Voltage applied to disabled output (see Note 1)	5.5 V
Operating free-air temperature range	0°C to 75°C
Storage temperature range	–65°C to 150°C

NOTE 1: These ratings apply except for programming pins during a programming cycle or during a preload cycle.

recommended operating conditions

		MIN	NOM	MAX	UNIT
V_{CC}	Supply voltage	4.75	5	5.25	V
V_{IH}	High-level input voltage (see Note 2)	2		5.5	V
V_{IL}	Low-level input voltage (see Note 2)			0.8	V
I_{OH}	High-level output current			–3.2	mA
I_{OL}	Low-level output current			24	mA
f_{clock}	Clock frequency	0		125	MHz
t_w	Pulse duration, clock	High		4	ns
		Low		4	
t_{su}	Setup time, input or feedback before clock↑	4.5			ns
t_h	Hold time, input or feedback after clock↑	0			ns
T_A	Operating free-air temperature	0	25	75	°C

NOTE 2: These are absolute voltage levels with respect to the ground pin of the device and include all overshoots due to system and/or tester noise. Testing these parameters should not be attempted without suitable equipment.

electrical characteristics over recommended operating free-air temperature range

PARAMETER	TEST CONDITIONS	TIBPAL16R8-5CFN			TIBPAL16R8-5CJ TIBPAL16R8-5CN			UNIT
		MIN	TYP†	MAX	MIN	TYP†	MAX	
V _{IK}	V _{CC} = 4.75 V, I _I = -18 mA	-0.8	-1.5		-0.8	-1.5		V
V _{OH}	V _{CC} = 4.75 V, I _{OH} = -3.2 mA	2.4	2.7		2.4	2.7		V
V _{OL}	V _{CC} = 4.75 V, I _{OL} = 24 mA		0.3	0.5		0.3	0.5	V
I _{OZH}	V _{CC} = 5.25 V, V _O = 2.7 V			100			100	μA
I _{OZL}	V _{CC} = 5.25 V, V _O = 0.4 V			-100			-100	μA
I _I	V _{CC} = 5.25 V, V _I = 5.5 V			100			100	μA
I _{IH}	V _{CC} = 5.25 V, V _I = 2.7 V			25			25	μA
I _{IL}	V _{CC} = 5.25 V, V _I = 0.4 V			-250			-250	μA
I _{OS‡}	V _{CC} = 5.25 V, V _O = 0.5 V	-30	-70	-130	-30	-70	-130	mA
I _{CC}	V _{CC} = 5.25 V, V _I = 0, Outputs open			180			180	mA
C _i	f = 1 MHz, V _I = 2 V	I			6.5			pF
		CLK/OE			5.5			
C _o	f = 1 MHz, V _O = 2 V	10			8			pF

switching characteristics over recommended ranges of supply voltage and operating free-air temperature (unless otherwise noted)

PARAMETER	FROM (INPUT)	TO (OUTPUT)	TEST CONDITIONS	TIBPAL16R8-5CFN			TIBPAL16R8-5CJ TIBPAL16R8-5CN			UNIT	
				MIN	TYP†	MAX	MIN	TYP†	MAX		
f _{max} §	without feedback		R1 = 200 Ω, R2 = 200 Ω, See Figure 8	125			125			MHz	
	with internal feedback (counter configuration)			125			125				
	with external feedback			117			111				
t _{pd}	CLK↑	Q		with up to 4 outputs switching	1.5			4			ns
	CLK↑	Q		with more than 4 outputs switching	1.5			4.5			
t _{pd} ¶	CLK↑	Internal feedback		3.5			3.5			ns	
t _{en}	$\overline{\text{OE}}\downarrow$	Q		1.5			6			ns	
t _{dis}	$\overline{\text{OE}}\uparrow$	Q		1			6.5			ns	
t _r				1.5			1.5			ns	
t _f				1.5			1.5			ns	
t _{sk(o)} #	Skew between outputs			0.5			0.5			ns	

† All typical values are at V_{CC} = 5 V, T_A = 25°C.

‡ Not more than one output should be shorted at a time, and the duration of the short circuit should not exceed one second. V_O is set at 0.5 V to avoid test problems caused by test equipment ground degradation.

§ See 'f_{max} Specification' near the end of this data sheet.

¶ This parameter is calculated from the measured f_{max} with internal feedback in a counter configuration (see Figure 2 for illustration).

t_{sk(o)} is the skew time between registered outputs.

TIBPAL16L8-7M, TIBPAL16R4-7M, TIBPAL16R6-7M, TIBPAL16R8-7M HIGH-PERFORMANCE *IMPACT-X*[™] *PAL*[®] CIRCUITS

SRPS011D – D3359, OCTOBER 1989 – REVISED SEPTEMBER 1992

absolute maximum ratings over operating free-air temperature range (unless otherwise noted)

Supply voltage, V_{CC} (see Note 1)	7 V
Input voltage (see Note 1)	5.5 V
Voltage applied to disabled output (see Note 1)	5.5 V
Operating free-air temperature range	–55°C to 125°C
Storage temperature range	–65°C to 150°C

NOTE 1: These ratings apply except for programming pins during a programming cycle or during a preload cycle.

recommended operating conditions

		MIN	NOM	MAX	UNIT
V_{CC}	Supply voltage	4.5	5	5.5	V
V_{IH}	High-level input voltage (see Note 2)	2		5.5	V
V_{IL}	Low-level input voltage (see Note 2)			0.8	V
I_{OH}	High-level output current			–2	mA
I_{OL}	Low-level output current			12	mA
f_{clock}^{\dagger}	Clock frequency	0		100	MHz
t_w^{\dagger}	Pulse duration, clock	High		5	ns
		Low		5	
t_{su}^{\dagger}	Setup time, input or feedback before clock \uparrow		7		ns
t_h^{\dagger}	Hold time, input or feedback after clock \uparrow		0		ns
T_A	Operating free-air temperature	–55	25	125	°C

$\dagger f_{clock}$, t_w , t_{su} , and t_h do not apply to TIBPAL16L8'

NOTE 2: These are absolute voltage levels with respect to the ground pin of the device and include all overshoots due to system and/or tester noise. Testing these parameters should not be attempted without suitable equipment.

PRODUCT PREVIEW

PRODUCT PREVIEW information concerns products in the formative or design phase of development. Characteristic data and other specifications are design goals. Texas Instruments reserves the right to change or discontinue these products without notice.



POST OFFICE BOX 655303 • DALLAS, TEXAS 75265

TIBPAL16L8-7M, TIBPAL16R4-7M, TIBPAL16R6-7M, TIBPAL16R8-7M HIGH-PERFORMANCE *IMPACT-X*TM PAL[®] CIRCUITS

SRPS011D – D3359, OCTOBER 1989 – REVISED SEPTEMBER 1992

electrical characteristics over recommended operating free-air temperature range

PARAMETER		TEST CONDITIONS		MIN	TYP†	MAX	UNIT
V _{IK}		V _{CC} = 4.5 V,	I _I = -18 mA		-0.8	-1.5	V
V _{OH}		V _{CC} = 4.5 V,	I _{OH} = -2 mA	2.4	2.7		V
V _{OL}		V _{CC} = 4.5 V,	I _{OL} = 12 mA		0.25	0.5	V
I _{OZH}	0, Q outputs	V _{CC} = 5.5 V,	V _O = 2.7 V			20	μA
	I/O ports					100	
I _{OZL}	0, Q outputs	V _{CC} = 5.5 V,	V _O = 0.4 V			-20	μA
	I/O ports					-250	
I _I		V _{CC} = 5.5 V,	V _I = 5.5 V			1	mA
I _{IH}	I/O ports	V _{CC} = 5.5 V,	V _I = 2.7 V			100	μA
	All others					25	
I _{IL}		V _{CC} = 5.5 V,	V _I = 0.4 V			-250	μA
I _{OS‡}		V _{CC} = 5.5 V,	V _O = 0.5 V	-30	-70	-130	mA
I _{CC}		V _{CC} = 5.5 V,	V _I = GND, $\overline{OE} = V_{IH}$, Outputs open			210	mA
C _i	I	f = 1 MHz,	V _I = 2 V			8.5	pF
	CLK/ \overline{OE}					7.5	
C _o		f = 1 MHz,	V _O = 2 V			10	pF

† All typical values are at V_{CC} = 5 V, T_A = 25°C.

‡ Not more than one output should be shorted at a time, and the duration of the short circuit should not exceed one second. V_O is set at 0.5 V to avoid test problems caused by test equipment ground degradation.

switching characteristics over recommended ranges of supply voltage and operating free-air temperature (unless otherwise noted)

PARAMETER	FROM (INPUT)	TO (OUTPUT)	TEST CONDITION	MIN	MAX	UNIT
f _{max} §	without feedback		R1 = 390 Ω, R2 = 750 Ω, See Figure 8	100		MHz
	with internal feedback (counter configuration)			100		
	with external feedback			74		
t _{pd}	I, I/O	O, I/O		1	7	ns
t _{pd}	CLK	Q		1	7	ns
t _{en}	OE↓	Q		1	8	ns
t _{dis}	OE↑	Q	1	10	ns	
t _{en}	I, I/O	O, I/O	1	9	ns	
t _{dis}	I, I/O	O, I/O	1	10	ns	

§ See 'f_{max} Specification' near the end of this data sheet. f_{max} does not apply for TIBPAL16L8'. f_{max} with external feedback is not production tested and is calculated from the equation located in the f_{max} specifications section.

PRODUCT PREVIEW

programming information

Texas Instruments programmable logic devices can be programmed using widely available software and inexpensive device programmers.

Complete programming specifications, algorithms, and the latest information on hardware, software, and firmware are available upon request. Information on programmers capable of programming Texas Instruments programmable logic is also available, upon request, from the nearest TI field sales office, local authorized TI distributor, or by calling Texas Instruments at (214) 997-5666.

asynchronous preload procedure for registered outputs (see Figure 1 and Note 3)†

The output registers can be preloaded to any desired state during device testing. This permits any state to be tested without having to step through the entire state-machine sequence. Each register is preloaded individually by following the steps given below.

- Step 1. With V_{CC} at 5 volts and Pin 1 at V_{IL} , raise Pin 11 to V_{IHH} .
- Step 2. Apply either V_{IL} or V_{IH} to the output corresponding to the register to be preloaded.
- Step 3. Lower Pin 11 to 5 V.
- Step 4. Remove output voltage, then lower Pin 11 to V_{IL} . Preload can be verified by observing the voltage level at the output pin.

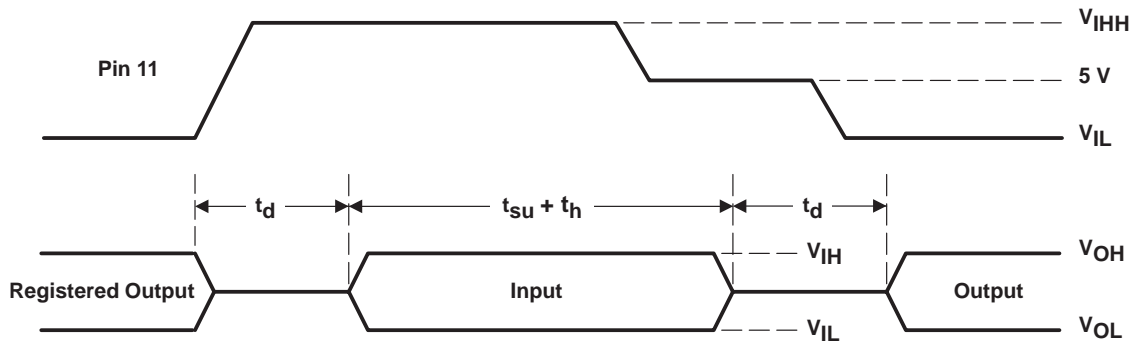

Figure 1. Asynchronous Preload Waveforms †

† Not applicable for TIBPAL16L8-5C and TIBPAL16L8-7M.

NOTE 3: $t_d = t_{su} = t_h = 100$ ns to 1000 ns

$V_{IHH} = 10.25$ V to 10.75 V

power-up reset (see Figure 2)

Following power up, all registers are reset to zero. This feature provides extra flexibility to the system designer and is especially valuable in simplifying state-machine initialization. To ensure a valid power-up reset, it is important that the rise of V_{CC} be monotonic. Following power-up reset, a low-to-high clock transition must not occur until all applicable input and feedback setup times are met.

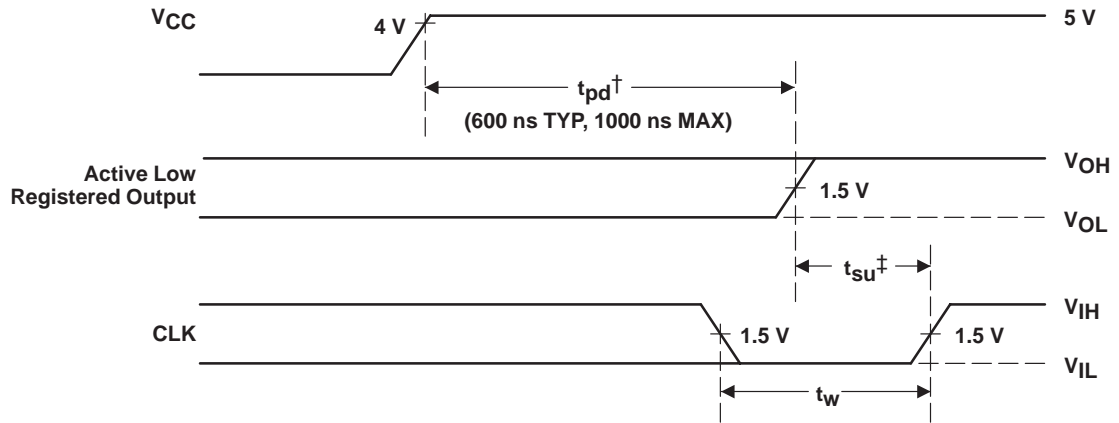

[†] This is the power-up reset time and applies to registered outputs only. The values shown are from characterization data.

[‡] This is the setup time for input or feedback.

Figure 2. Power-Up Reset Waveforms

f_{max} SPECIFICATIONS

f_{max} without feedback (see Figure 3)

In this mode, data is presented at the input to the flip-flop and clocked through to the Q output with no feedback. Under this condition, the clock period is limited by the sum of the data setup time and the data hold time (t_{su} + t_h). However, the minimum f_{max} is determined by the minimum clock period (t_w high + t_w low).

$$\text{Thus, } f_{\text{max}} \text{ without feedback} = \frac{1}{(t_{w\text{high}} + t_{w\text{low}})} \text{ or } \frac{1}{(t_{\text{su}} + t_{\text{h}})}$$

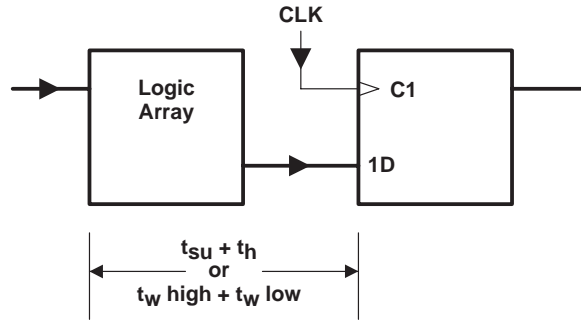

Figure 3. f_{max} Without Feedback

f_{max} with internal feedback (see Figure 4)

This configuration is most popular in counters and on-chip state-machine designs. The flip-flop inputs are defined by the device inputs and flip-flop outputs. Under this condition, the period is limited by the internal delay from the flip-flop outputs through the internal feedback and logic array to the inputs of the next flip-flop.

$$\text{Thus, } f_{\text{max}} \text{ with internal feedback} = \frac{1}{(t_{\text{su}} + t_{\text{pd CLK-to-FB}})}$$

Where t_{pd} CLK-to-FB is the deduced value of the delay from CLK to the input of the logic array.

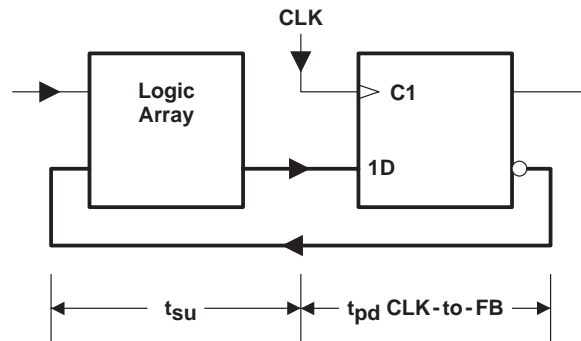

Figure 4. f_{max} With Internal Feedback

f_{max} SPECIFICATIONS

f_{max} with external feedback (see Figure 5)

This configuration is a typical state-machine design with feedback signals sent off-chip. This external feedback could go back to the device inputs or to a second device in a multi-chip state machine. The slowest path defining the period is the sum of the clock-to-output time and the input setup time for the external signals ($t_{su} + t_{pd \text{ CLK-to-Q}}$).

$$\text{Thus, } f_{\text{max}} \text{ with external feedback} = \frac{1}{(t_{\text{su}} + t_{\text{pd CLK-to-Q}})}$$

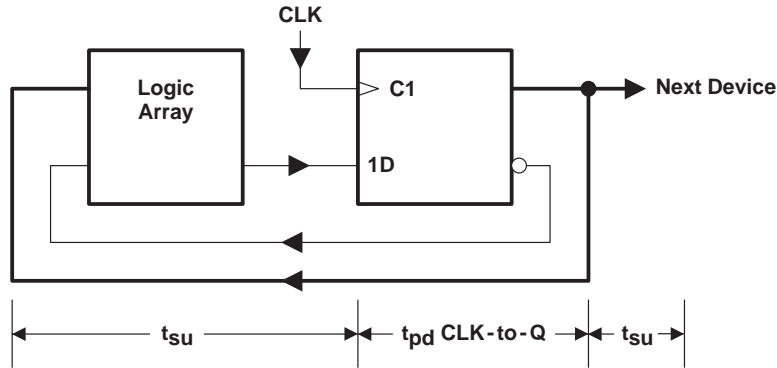

Figure 5. f_{max} With External Feedback

THERMAL INFORMATION

thermal management of the TIBPAL16R8-5C

Thermal management of the TIBPAL16R8-5CN and TIBPAL16R8-5CFN is necessary when operating at certain conditions of frequency, output loading, and outputs switching simultaneously. The device and system application will determine the appropriate level of management.

Determining the level of thermal management is based on factors such as power dissipation (P_D), ambient temperature (T_A), and transverse airflow (FPM). Figures 6 (a) and 6 (b) show the relationship between ambient temperature and transverse airflow at given power dissipation levels. The required transverse airflow can be determined at a particular ambient temperature and device power dissipation level in order to ensure the device specifications.

Figure 7 illustrates how power dissipation varies as a function of frequency and the number of outputs switching simultaneously. It should be noted that all outputs are fully loaded ($C_L = 50$ pF). Since the condition of eight fully loaded outputs represents the worst-case condition, each application must be evaluated accordingly.

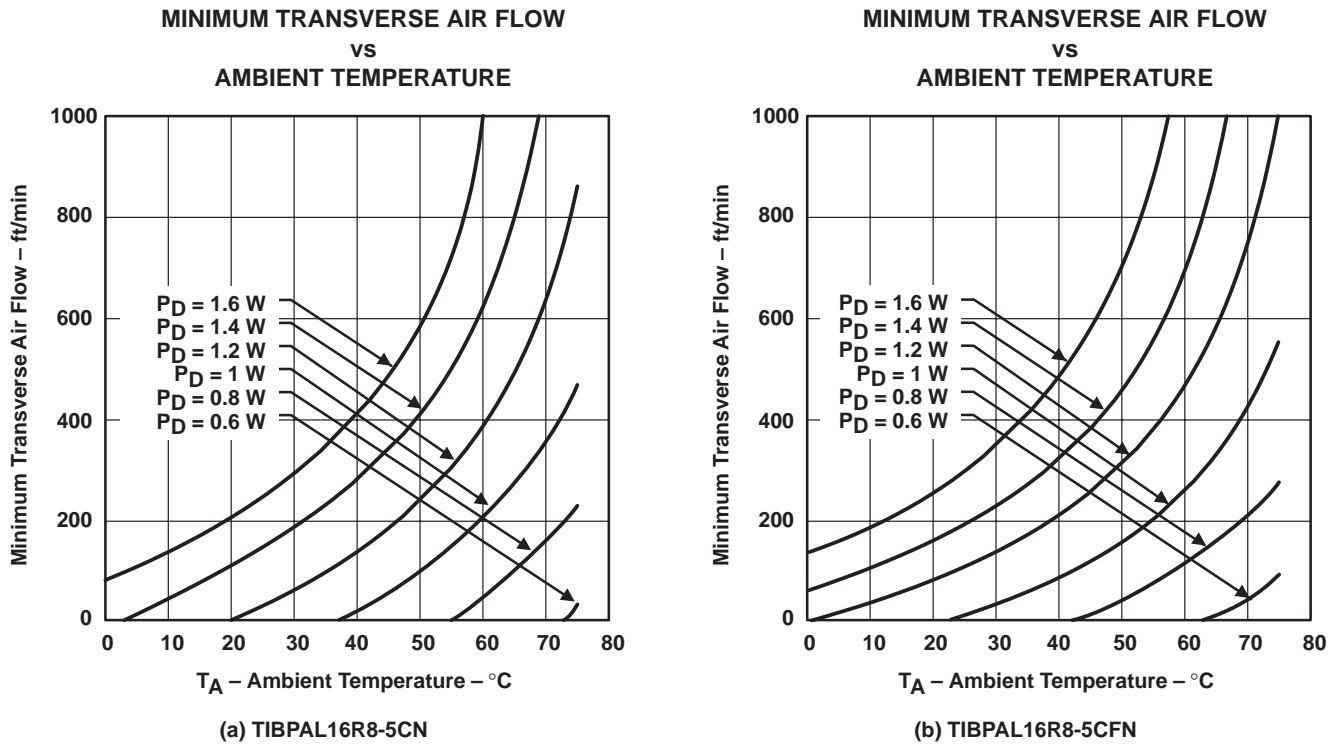

Figure 6

THERMAL INFORMATION

**POWER DISSIPATION
 vs
 FREQUENCY**

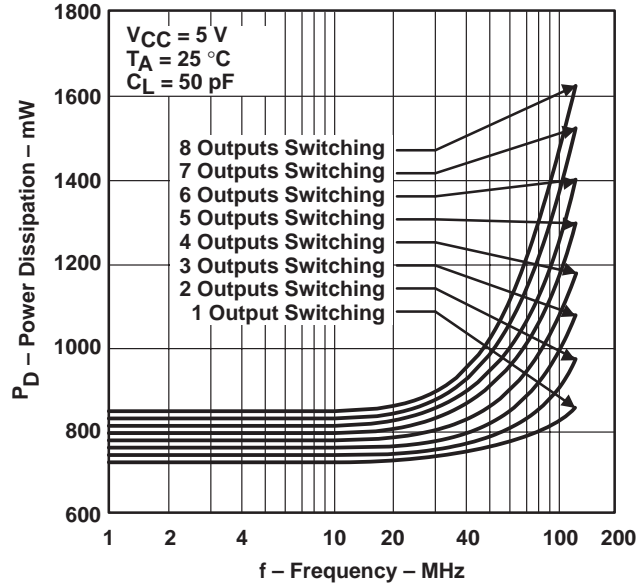
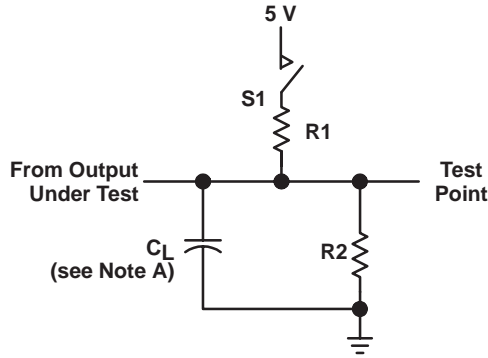
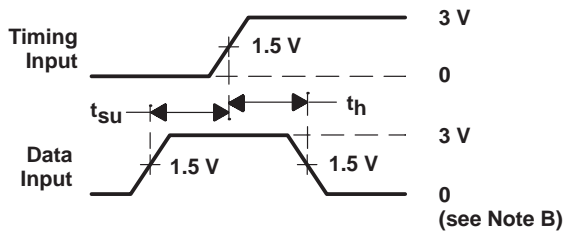

Figure 7

PARAMETER MEASUREMENT INFORMATION



LOAD CIRCUIT FOR 3-STATE OUTPUTS



VOLTAGE WAVEFORMS SETUP AND HOLD TIMES

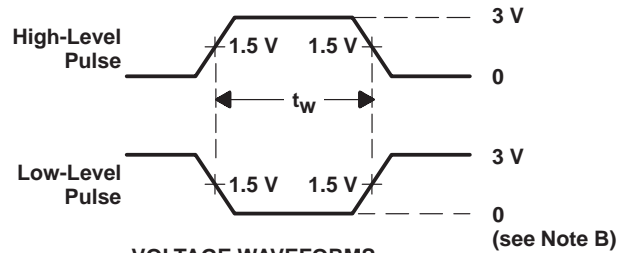

VOLTAGE WAVEFORMS PULSE DURATIONS

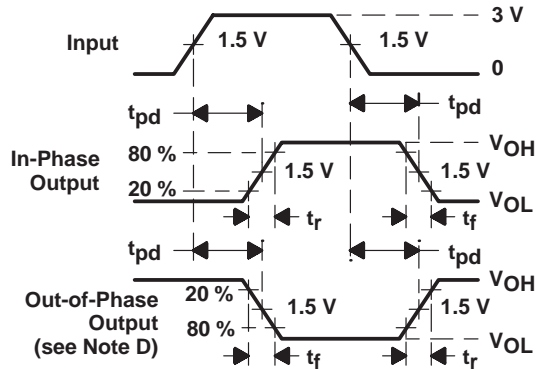

VOLTAGE WAVEFORMS PROPAGATION DELAY TIMES

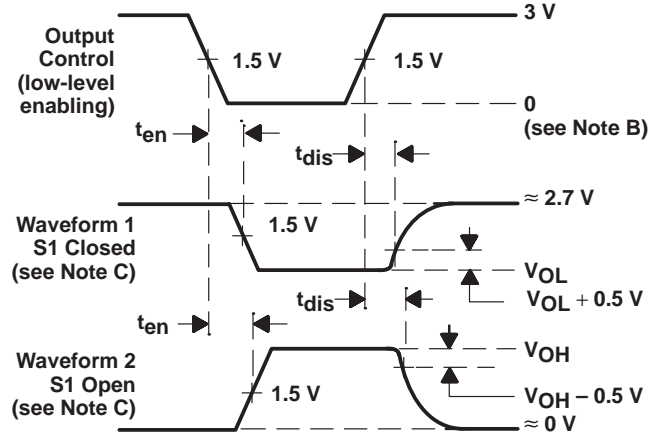

VOLTAGE WAVEFORMS ENABLE AND DISABLE TIMES, 3-STATE OUTPUTS

- NOTES: A. C_L includes probe and jig capacitance and is 50 pF for t_{pd} and t_{en} , 5 pF for t_{dis} .
 B. All input pulses have the following characteristics: For C suffix, $PRR \leq 1$ MHz, $t_r = t_f = 2$ ns, duty cycle = 50%; For M suffix, $PRR \leq 10$ MHz, $t_r = t_f \leq 2$ ns, duty cycle = 50%.
 C. Waveform 1 is for an output with internal conditions such that the output is low except when disabled by the output control. Waveform 2 is for an output with internal conditions such that the output is high except when disabled by the output control.
 D. When measuring propagation delay times of 3-state outputs, switch S1 is closed.
 E. Equivalent loads may be used for testing.

Figure 8. Load Circuit and Voltage Waveforms

metastable characteristics of TIBPAL16R4-5C, TIBPAL16R6-5C, and TIBPAL16R8-5C

At some point a system designer is faced with the problem of synchronizing two digital signals operating at two different frequencies. This problem is typically overcome by synchronizing one of the signals to the local clock through use of a flip-flop. However, this solution presents an awkward dilemma since the setup and hold time specifications associated with the flip-flop are sure to be violated. The metastable characteristics of the flip-flop can influence overall system reliability.

Whenever the setup and hold times of a flip-flop are violated, its output response becomes uncertain and is said to be in the metastable state if the output hangs up in the region between V_{IL} and V_{IH} . This metastable condition lasts until the flip-flop falls into one of its two stable states, which takes longer than the specified maximum propagation delay time (CLK to Q max).

From a system engineering standpoint, a designer cannot use the specified data sheet maximum for propagation delay time when using the flip-flop as a data synchronizer – how long to wait after the specified data sheet maximum must be known before using the data in order to guarantee reliable system operation.

The circuit shown in Figure 9 can be used to evaluate MTBF (Mean Time Between Failure) and Δt for a selected flip-flop. Whenever the Q output of the DUT is between 0.8 V and 2 V, the comparators are in opposite states. When the Q output of the DUT is higher than 2 V or lower than 0.8 V, the comparators are at the same logic level. The outputs of the two comparators are sampled a selected time (Δt) after system clock (SCLK). The exclusive OR gate detects the occurrence of a failure and increments the failure counter.

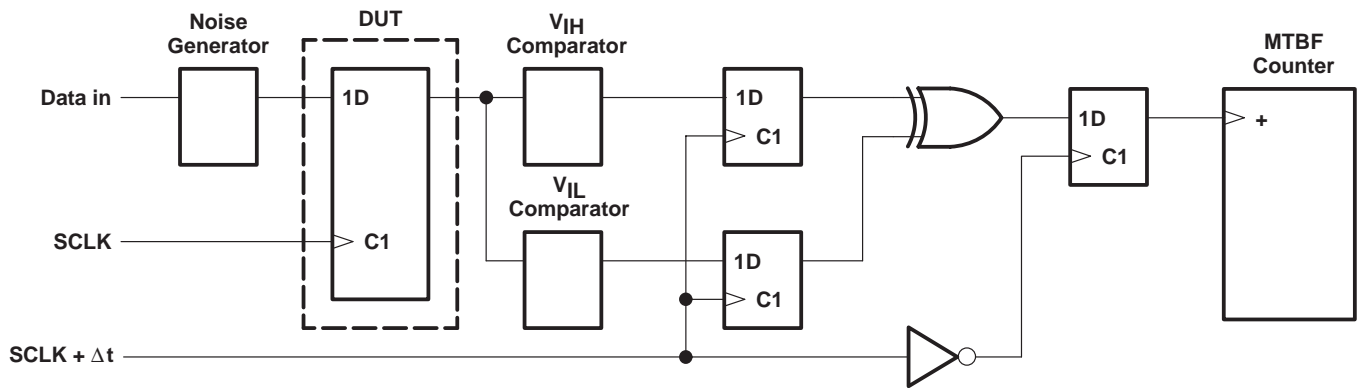

Figure 9. Metastable Evaluation Test Circuit

In order to maximize the possibility of forcing the DUT into a metastable state, the input data signal is applied so that it always violates the setup and hold time. This condition is illustrated in the timing diagram in Figure 10. Any other relationship of SCLK to data will provide less chance for the device to enter into the metastable state.

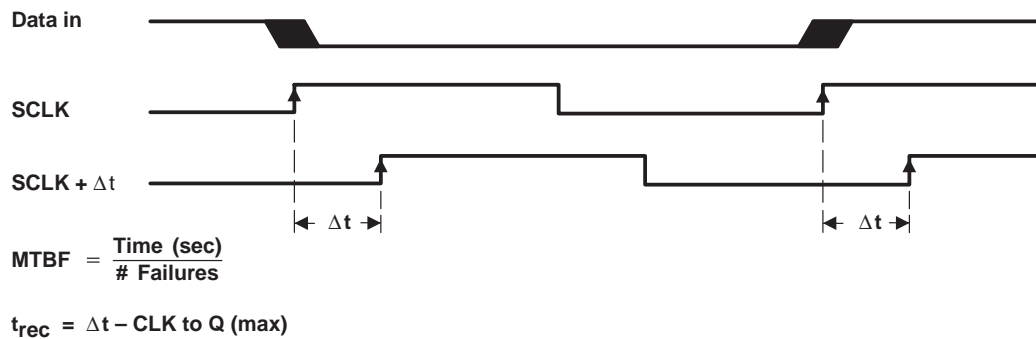

Figure 10. Timing Diagram

By using the described test circuit, MTBF can be determined for several different values of Δt (see Figure 9). Plotting this information on semilog scale demonstrates the metastable characteristics of the selected flip-flop. Figure 11 shows the results for the TIBPAL16'-5C operating at 1 MHz.

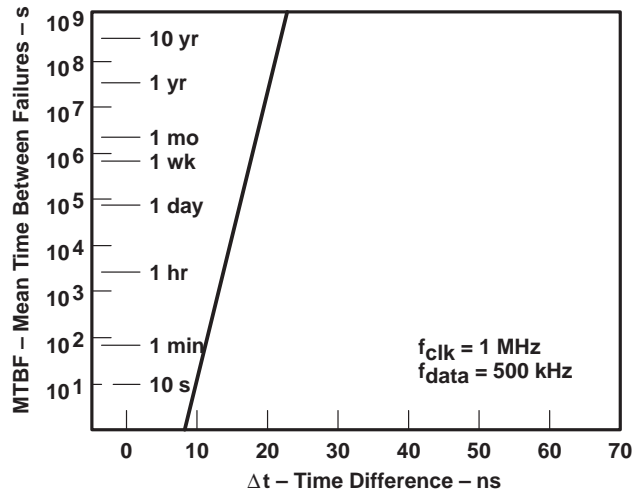

Figure 11. Metastable Characteristics

From the data taken in the above experiment, an equation can be derived for the metastable characteristics at other clock frequencies.

The metastable equation: $\frac{1}{\text{MTBF}} = f_{\text{SCLK}} \times f_{\text{data}} \times C1 \times e^{-C2 \times \Delta t}$

The constants C1 and C2 describe the metastable characteristics of the device. From the experimental data, these constants can be solved for: $C1 = 4.37 \times 10^{-3}$ and $C2 = 2.01$

Therefore

$$\frac{1}{\text{MTBF}} = f_{\text{SCLK}} \times f_{\text{data}} \times 4.37 \times 10^{-3} \times e^{-2.01 \times \Delta t}$$

definition of variables

DUT (Device Under Test): The DUT is a 5-ns registered PLD programmed with the equation $Q = D$.

MTBF (Mean Time Between Failures): The average time (s) between metastable occurrences that cause a violation of the device specifications.

f_{SCLK} (system clock frequency): Actual clock frequency for the DUT.

f_{data} (data frequency): Actual data frequency for a specified input to the DUT.

C1: Calculated constant that defines the magnitude of the curve.

C2: Calculated constant that defines the slope of the curve.

t_{rec} (metastability recovery time): Minimum time required to guarantee recovery from metastability, at a given MTBF failure rate. $t_{\text{rec}} = \Delta t - t_{\text{pd}}$ (CLK to Q, max)

Δt : The time difference (ns) from when the synchronizing flip-flop is clocked to when its output is sampled.

The test described above has shown the metastable characteristics of the TIBPAL16R4/R6/R8-5C series. For additional information on metastable characteristics of Texas Instruments logic circuits, please refer to TI Applications publication SDAA004, "Metastable Characteristics, Design Considerations for ALS, AS, and LS Circuits."

TYPICAL CHARACTERISTICS

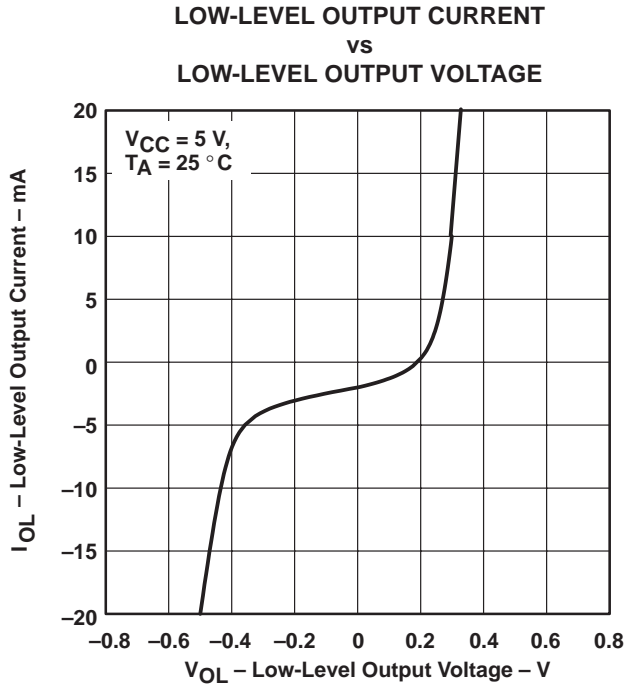

Figure 12

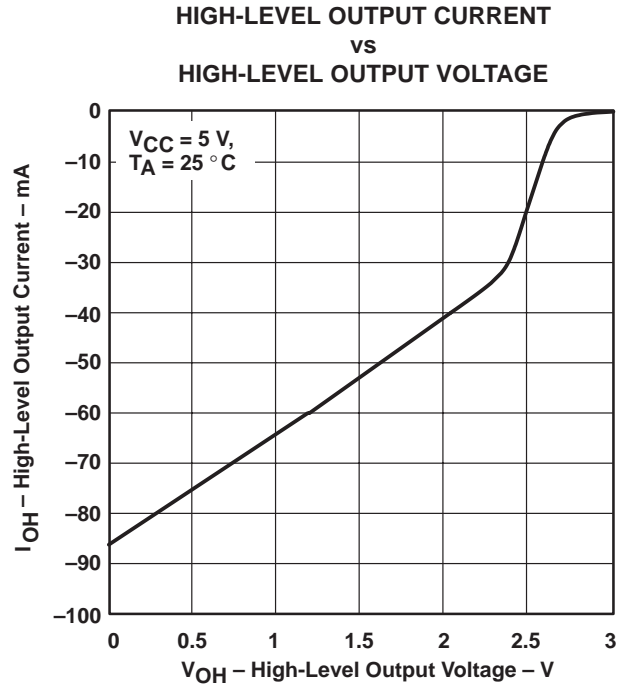

Figure 13

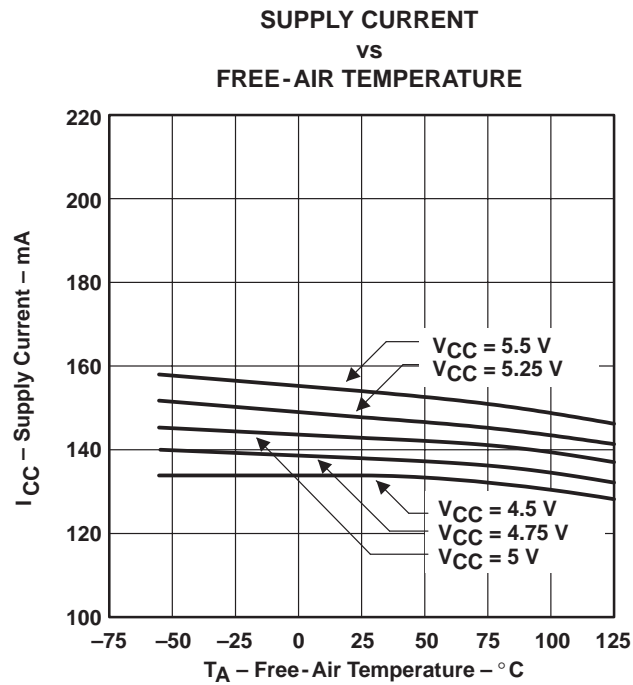

Figure 14

TYPICAL CHARACTERISTICS

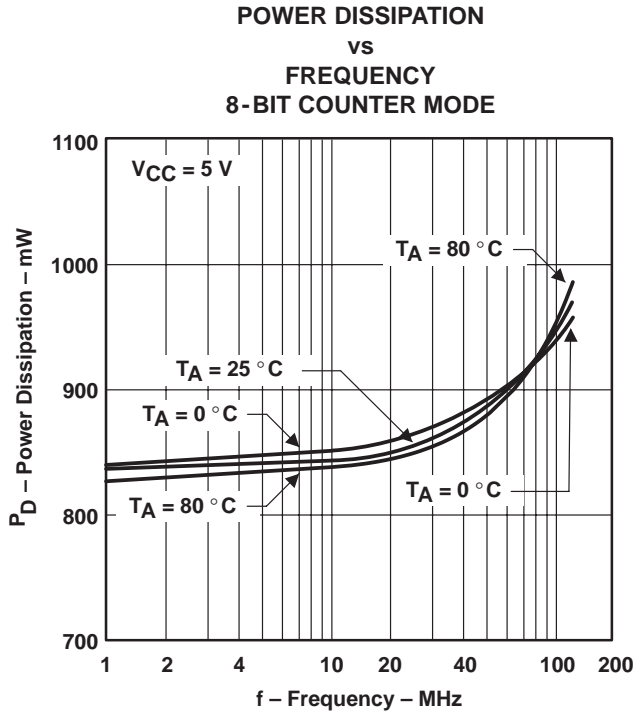

Figure 15

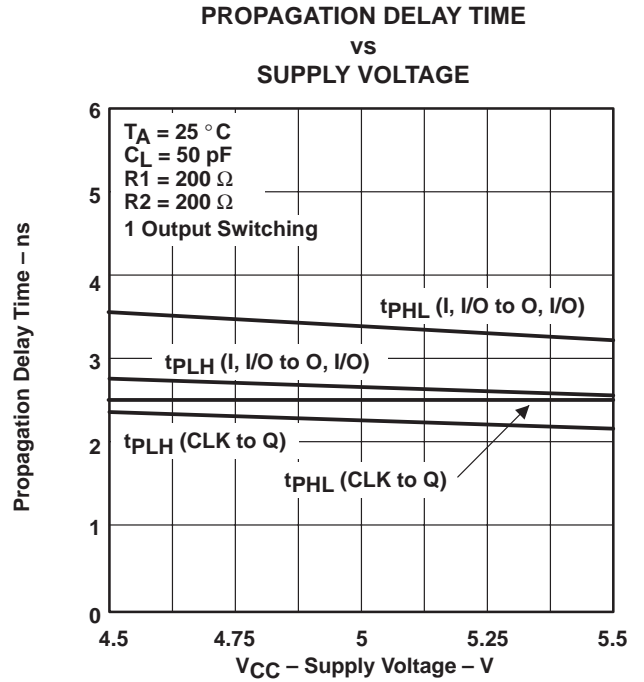

Figure 16

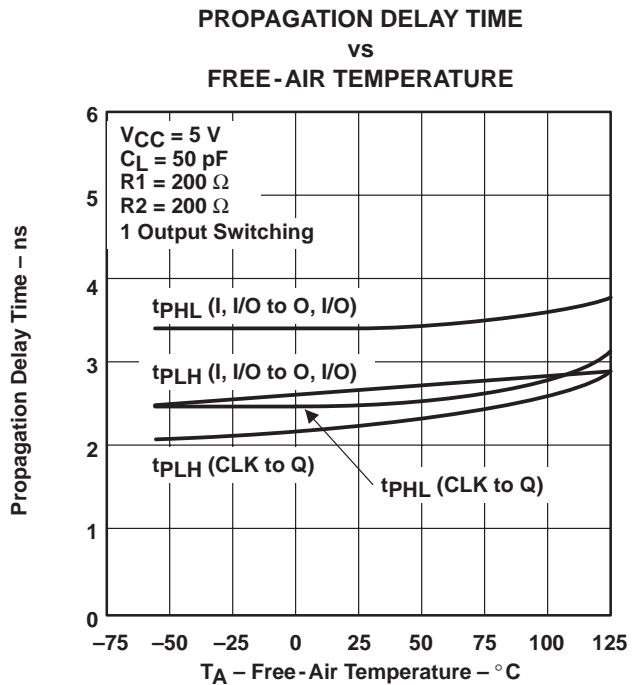

Figure 17

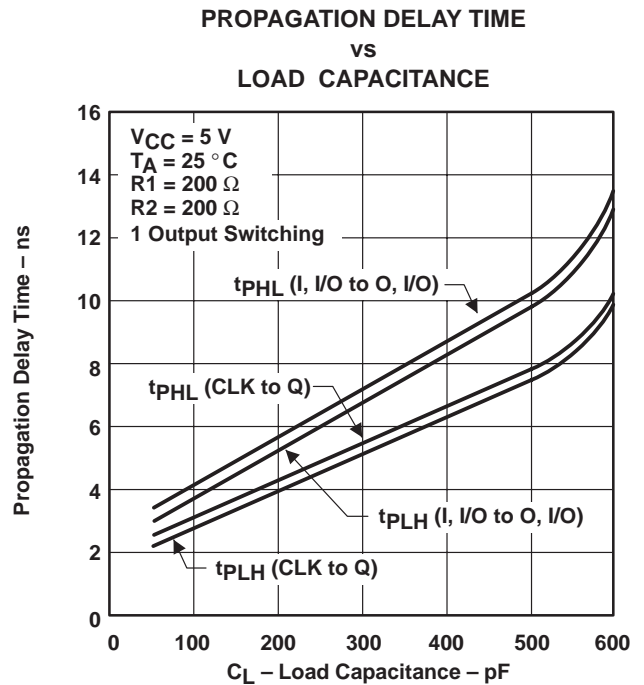

Figure 18

TYPICAL CHARACTERISTICS

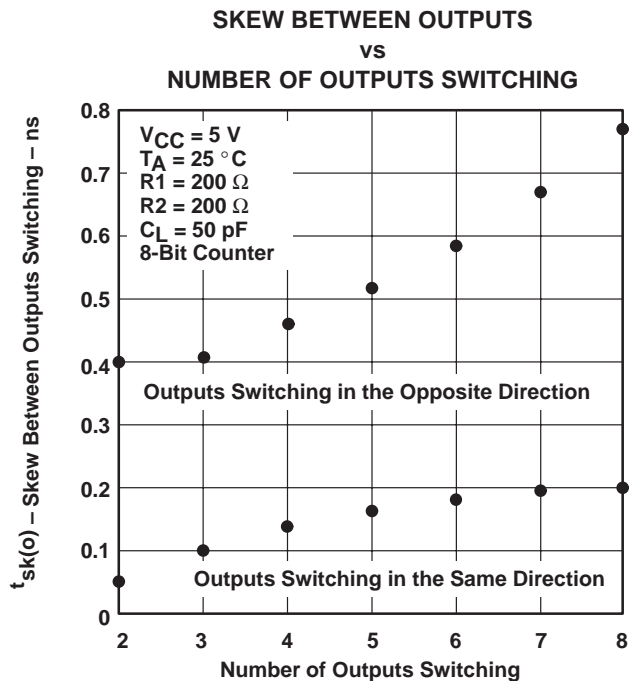

Figure 19

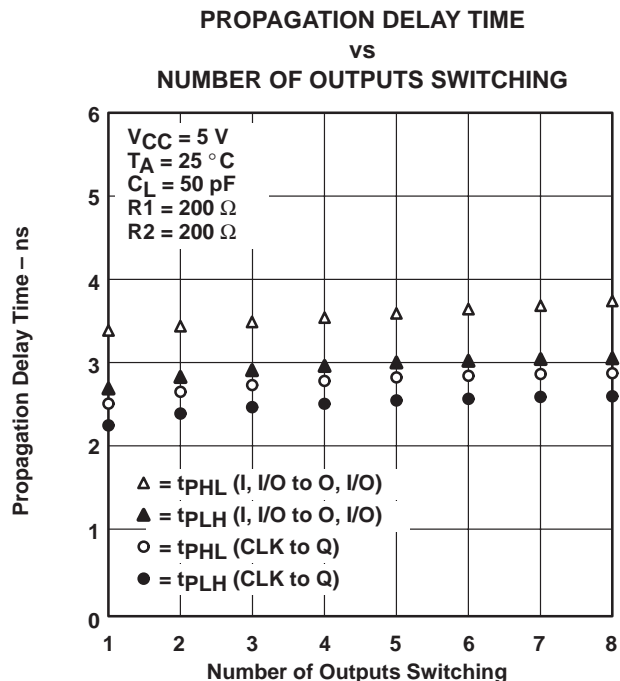

Figure 20

TI North American Sales Offices

ALABAMA: Huntsville: (205) 837-7530
ARIZONA: Phoenix: (602) 995-1007
CALIFORNIA: Irvine: (714) 660-1200
 San Diego: (619) 278-9600
 Santa Clara: (408) 980-9000
 Woodland Hills: (818) 704-8100
COLORADO: Aurora: (303) 368-8000
CONNECTICUT: Wallingford: (203) 269-0074
FLORIDA: Altamonte Springs: (407) 260-2116
 Fort Lauderdale: (305) 973-8502
 Tampa: (813) 885-7588
GEORGIA: Norcross: (404) 662-7967
ILLINOIS: Arlington Heights: (708) 640-3000
INDIANA: Carmel: (317) 573-6400
 Fort Wayne: (219) 489-4697
KANSAS: Overland Park: (913) 451-4511
MARYLAND: Columbia: (410) 964-2003
MASSACHUSETTS: Waltham: (617) 895-9100
MICHIGAN: Farmington Hills: (313) 553-1581
MINNESOTA: Eden Prairie: (612) 828-9300
MISSOURI: St. Louis: (314) 821-8400
NEW JERSEY: Iselin: (908) 750-1050
NEW MEXICO: Albuquerque: (505) 345-2555
NEW YORK: East Syracuse: (315) 463-9291
 Fishkill: (914) 897-2900
 Melville: (516) 454-6600
 Pittsford: (716) 385-6770
NORTH CAROLINA: Charlotte: (704) 527-0930
 Raleigh: (919) 876-2725
OHIO: Beachwood: (216) 765-7258
 Beavercreek: (513) 427-6200
OREGON: Beaverton: (503) 643-6758
PENNSYLVANIA: Blue Bell: (215) 825-9500
PUERTO RICO: Hato Rey: (809) 753-8700
TEXAS: Austin: (512) 250-6769
 Dallas: (214) 917-1264
 Houston: (713) 778-6592
 Midland: (915) 561-7137
UTAH: Salt Lake City: (801) 466-8972
WISCONSIN: Waukesha: (414) 798-1001
CANADA: Nepean: (613) 726-1970
 Richmond Hill: (416) 884-9181
 St. Laurent: (514) 335-8392

TI Regional Technology Centers

CALIFORNIA: Irvine: (714) 660-8140
 Santa Clara: (408) 748-2222
GEORGIA: Norcross: (404) 662-7945
ILLINOIS: Arlington Heights: (708) 640-2909
INDIANA: Indianapolis: (317) 573-6400
MASSACHUSETTS: Waltham: (617) 895-9196
MEXICO: Mexico City: 491-70834
MINNESOTA: Minneapolis: (612) 828-9300
TEXAS: Dallas: (214) 917-3881
CANADA: Nepean: (613) 726-1970

Customer Response Center

TOLL FREE: (800) 336-5236
OUTSIDE USA: (214) 995-6611
 (8:00 a.m. – 5:00 p.m. CST)

TI Authorized North American Distributors

Alliance Electronics, Inc. (military product only)
 Almac/Arrow
 Anthem Electronics
 Arrow/Schweber
 Future Electronics (Canada)
 GRS Electronics Co., Inc.
 Hall-Mark Electronics
 Marshall Industries
 Newark Electronics
 Rochester Electronics, Inc.
 (obsolete product only) (508) 462-9332
 Wyle Laboratories
 Zeus Components

TI Distributors

ALABAMA: Arrow/Schweber (205) 837-6955; Hall-Mark (205) 837-8700; Marshall (205) 881-9235.
ARIZONA: Anthem (602) 966-6600; Arrow/Schweber (602) 437-0750; Hall-Mark (602) 431-0030; Marshall (602) 496-0290; Wyle (602) 437-2088.
CALIFORNIA: Los Angeles/Orange County: Anthem (818) 775-1333, (714) 768-4444; Arrow/Schweber (818) 380-9686, (714) 838-5422; Hall-Mark (818) 773-4500, (714) 727-6000; Marshall (818) 878-7000, (714) 458-5301; Wyle (818) 880-9000, (714) 863-9953; Zeus (714) 921-9000, (818) 889-3838;
 Sacramento: Anthem (916) 624-9744; Hall-Mark (916) 624-9781; Marshall (916) 635-9700; Wyle (916) 638-5282;
 San Diego: Anthem (619) 453-9005; Arrow/Schweber (619) 565-4800; Hall-Mark (619) 268-1201; Marshall (619) 578-9600; Wyle (619) 565-9171; Zeus (619) 277-9681.
 San Francisco Bay Area: Anthem (408) 453-1200; Arrow/Schweber (408) 441-9700, (510) 490-9477; Hall-Mark (408) 432-4000; Marshall (408) 942-4600; Wyle (408) 727-2500; Zeus (408) 629-4789.
COLORADO: Anthem (303) 790-4500; Arrow/Schweber (303) 799-0258; Hall-Mark (303) 790-1662; Marshall (303) 451-8383; Wyle (303) 457-9953.
CONNECTICUT: Anthem (203) 575-1575; Arrow/Schweber (203) 265-7741; Hall-Mark (203) 271-2844; Marshall (203) 265-3822.
FLORIDA: Fort Lauderdale: Arrow/Schweber (305) 429-8200; Hall-Mark (305) 971-9280; Marshall (305) 977-4880.
 Orlando: Arrow/Schweber (407) 333-9300; Hall-Mark (407) 830-5855; Marshall (407) 767-8585; Zeus (407) 788-9100.
 Tampa: Hall-Mark (813) 541-7440; Marshall (813) 573-1399.
GEORGIA: Arrow/Schweber (404) 497-1300; Hall-Mark (404) 623-4400; Marshall (404) 923-5750.
ILLINOIS: Anthem (708) 884-0200; Arrow/Schweber (708) 250-0500; Hall-Mark (312) 860-3800; Marshall (708) 490-0155; Newark (312) 784-5100.
INDIANA: Arrow/Schweber (317) 299-2071; Hall-Mark (317) 872-8875; Marshall (317) 297-0483.
IOWA: Arrow/Schweber (319) 395-7230.
KANSAS: Arrow/Schweber (913) 541-9542; Hall-Mark (913) 888-4747; Marshall (913) 492-3121.
MARYLAND: Anthem (301) 995-6640; Arrow/Schweber (301) 596-7800; Hall-Mark (301) 988-9800; Marshall (301) 622-1118; Zeus (301) 997-1118.
MASSACHUSETTS: Anthem (508) 657-5170; Arrow/Schweber (508) 658-0900; Hall-Mark (508) 667-0902; Marshall (508) 658-0810; Wyle (617) 272-7300; Zeus (617) 246-8200.

MICHIGAN: Detroit: Arrow/Schweber (313) 462-2290; Hall-Mark (313) 416-5800; Marshall (313) 525-5850; Newark (313) 967-0600.
MINNESOTA: Anthem (612) 944-5454; Arrow/Schweber (612) 941-5280; Hall-Mark (612) 881-2600; Marshall (612) 559-2211.
MISSOURI: Arrow/Schweber (314) 567-6888; Hall-Mark (314) 291-5350; Marshall (314) 291-4650.
NEW JERSEY: Anthem (201) 227-7960; Arrow/Schweber (201) 227-7880, (609) 596-8000; Hall-Mark (201) 515-3000, (609) 235-1900; Marshall (201) 882-0320, (609) 234-9100.
NEW MEXICO: Alliance (505) 292-3360.
NEW YORK: Long Island: Anthem (516) 864-6600; Arrow/Schweber (516) 231-1000; Hall-Mark (516) 737-0600; Marshall (516) 273-2424; Zeus (914) 937-7400.
Rochester: Arrow/Schweber (716) 427-0300; Hall-Mark (716) 425-3300; Marshall (716) 235-7620.
Syracuse: Marshall (607) 785-2345.
NORTH CAROLINA: Arrow/Schweber (919) 876-3132; Hall-Mark (919) 872-0712; Marshall (919) 878-9882.
OHIO: Cleveland: Arrow/Schweber (216) 248-3990; Hall-Mark (216) 349-4632; Marshall (216) 248-1788.
Columbus: Hall-Mark (614) 888-3313.
Dayton: Arrow/Schweber (513) 435-5563; Marshall (513) 898-4480; Zeus (513) 293-6162.
OKLAHOMA: Arrow/Schweber (918) 252-7537; Hall-Mark (918) 254-6110.
OREGON: Almac/Arrow (503) 629-8090; Anthem (503) 643-1114; Marshall (503) 644-5050; Wyle (503) 643-7900.
PENNSYLVANIA: Anthem (215) 443-5150; Arrow/Schweber (215) 928-1800; GRS (215) 922-7037; (609) 964-8560; Marshall (412) 788-0441.
TEXAS: Austin: Arrow/Schweber (512) 835-4180; Hall-Mark (512) 258-8848; Marshall (512) 837-1991; Wyle (512) 345-8853;
 Dallas: Anthem (214) 238-7100; Arrow/Schweber (214) 380-6464; Hall-Mark (214) 553-4300; Marshall (214) 233-5200; Wyle (214) 235-9953; Zeus (214) 783-7010;
 Houston: Arrow/Schweber (713) 530-4700; Hall-Mark (713) 781-6100; Marshall (713) 467-1666; Wyle (713) 879-9953.
UTAH: Anthem (801) 973-8555; Arrow/Schweber (801) 973-6913; Marshall (801) 973-2288; Wyle (801) 974-9953.
WASHINGTON: Almac/Arrow (206) 643-9992; Anthem (206) 483-1700; Marshall (206) 486-5747; Wyle (206) 881-1150.
WISCONSIN: Arrow/Schweber (414) 792-0150; Hall-Mark (414) 797-7844; Marshall (414) 797-8400.
CANADA: Calgary: Future (403) 235-5325;
 Edmonton: Future (403) 438-2858;
 Montreal: Arrow/Schweber (514) 421-7411; Future (514) 694-7710; Marshall (514) 694-8142
 Ottawa: Arrow/Schweber (613) 226-6903; Future (613) 820-8313.
 Quebec: Future (418) 897-6666.
 Toronto: Arrow/Schweber (416) 670-7769; Future (416) 612-9200; Marshall (416) 458-8046.
 Vancouver: Arrow/Schweber (604) 421-2333; Future (604) 294-1166.

TI Die Processors

Chip Supply (407) 298-7100
 Elmo Semiconductor (818) 768-7400
 Minco Technology Labs (512) 834-2022



D0892

PACKAGING INFORMATION

Orderable Device	Status ⁽¹⁾	Package Type	Package Drawing	Pins	Package Qty	Eco Plan ⁽²⁾	Lead/Ball Finish	MSL Peak Temp ⁽³⁾
5962-85155212A	ACTIVE	LCCC	FK	20	1	TBD	POST-PLATE	N / A for Pkg Type
5962-8515521RA	ACTIVE	CDIP	J	20	1	TBD	A42	N / A for Pkg Type
5962-8515521SA	ACTIVE	CFP	W	20	1	TBD	Call TI	N / A for Pkg Type
TIBPAL16L8-5CFN	OBSOLETE	PLCC	FN	20		TBD	Call TI	Call TI
TIBPAL16L8-5CN	OBSOLETE	PDIP	N	20		TBD	Call TI	Call TI
TIBPAL16R4-5CN	OBSOLETE	PDIP	N	20		TBD	Call TI	Call TI
TIBPAL16R6-5CFN	ACTIVE	PLCC	FN	20	46	TBD	CU SNPB	Level-1-220C-UNLIM
TIBPAL16R6-5CN	ACTIVE	PDIP	N	20	20	Pb-Free (RoHS)	CU NIPDAU	N / A for Pkg Type
TIBPAL16R8-5CFN	ACTIVE	PLCC	FN	20	46	TBD	CU SNPB	Level-1-220C-UNLIM
TIBPAL16R8-5CN	ACTIVE	PDIP	N	20	20	Pb-Free (RoHS)	CU NIPDAU	N / A for Pkg Type
TIBPAL16R8-7MFKB	ACTIVE	LCCC	FK	20	1	TBD	POST-PLATE	N / A for Pkg Type
TIBPAL16R8-7MJB	ACTIVE	CDIP	J	20	1	TBD	A42	N / A for Pkg Type
TIBPAL16R8-7MWB	ACTIVE	CFP	W	20	1	TBD	Call TI	N / A for Pkg Type

⁽¹⁾ The marketing status values are defined as follows:

ACTIVE: Product device recommended for new designs.

LIFEBUY: TI has announced that the device will be discontinued, and a lifetime-buy period is in effect.

NRND: Not recommended for new designs. Device is in production to support existing customers, but TI does not recommend using this part in a new design.

PREVIEW: Device has been announced but is not in production. Samples may or may not be available.

OBSOLETE: TI has discontinued the production of the device.

⁽²⁾ Eco Plan - The planned eco-friendly classification: Pb-Free (RoHS), Pb-Free (RoHS Exempt), or Green (RoHS & no Sb/Br) - please check <http://www.ti.com/productcontent> for the latest availability information and additional product content details.

TBD: The Pb-Free/Green conversion plan has not been defined.

Pb-Free (RoHS): TI's terms "Lead-Free" or "Pb-Free" mean semiconductor products that are compatible with the current RoHS requirements for all 6 substances, including the requirement that lead not exceed 0.1% by weight in homogeneous materials. Where designed to be soldered at high temperatures, TI Pb-Free products are suitable for use in specified lead-free processes.

Pb-Free (RoHS Exempt): This component has a RoHS exemption for either 1) lead-based flip-chip solder bumps used between the die and package, or 2) lead-based die adhesive used between the die and leadframe. The component is otherwise considered Pb-Free (RoHS compatible) as defined above.

Green (RoHS & no Sb/Br): TI defines "Green" to mean Pb-Free (RoHS compatible), and free of Bromine (Br) and Antimony (Sb) based flame retardants (Br or Sb do not exceed 0.1% by weight in homogeneous material)

⁽³⁾ MSL, Peak Temp. -- The Moisture Sensitivity Level rating according to the JEDEC industry standard classifications, and peak solder temperature.

Important Information and Disclaimer: The information provided on this page represents TI's knowledge and belief as of the date that it is provided. TI bases its knowledge and belief on information provided by third parties, and makes no representation or warranty as to the accuracy of such information. Efforts are underway to better integrate information from third parties. TI has taken and continues to take reasonable steps to provide representative and accurate information but may not have conducted destructive testing or chemical analysis on incoming materials and chemicals. TI and TI suppliers consider certain information to be proprietary, and thus CAS numbers and other limited information may not be available for release.

In no event shall TI's liability arising out of such information exceed the total purchase price of the TI part(s) at issue in this document sold by TI to Customer on an annual basis.

FK (S-CQCC-N**)

LEADLESS CERAMIC CHIP CARRIER

28 TERMINAL SHOWN

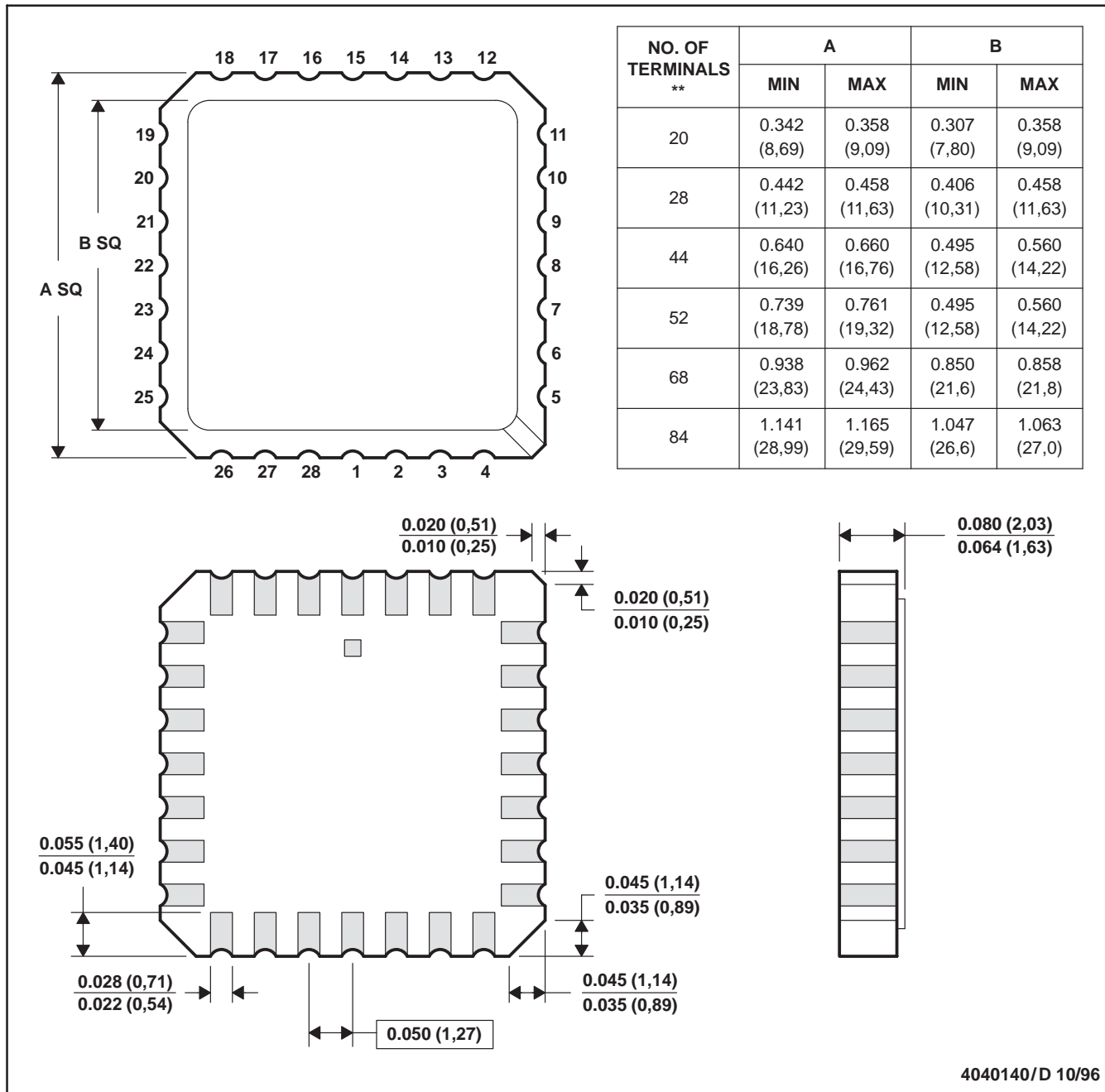

- NOTES:
- A. All linear dimensions are in inches (millimeters).
 - B. This drawing is subject to change without notice.
 - C. This package can be hermetically sealed with a metal lid.
 - D. The terminals are gold plated.
 - E. Falls within JEDEC MS-004

J (R-GDIP-T**)

14 LEADS SHOWN

CERAMIC DUAL IN-LINE PACKAGE

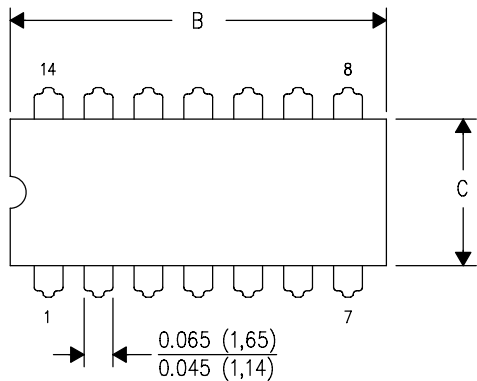

DIM \ PINS **	14	16	18	20
A	0.300 (7,62) BSC	0.300 (7,62) BSC	0.300 (7,62) BSC	0.300 (7,62) BSC
B MAX	0.785 (19,94)	.840 (21,34)	0.960 (24,38)	1.060 (26,92)
B MIN	—	—	—	—
C MAX	0.300 (7,62)	0.300 (7,62)	0.310 (7,87)	0.300 (7,62)
C MIN	0.245 (6,22)	0.245 (6,22)	0.220 (5,59)	0.245 (6,22)



4040083/F 03/03

- NOTES:
- All linear dimensions are in inches (millimeters).
 - This drawing is subject to change without notice.
 - This package is hermetically sealed with a ceramic lid using glass frit.
 - Index point is provided on cap for terminal identification only on press ceramic glass frit seal only.
 - Falls within MIL STD 1835 GDIP1-T14, GDIP1-T16, GDIP1-T18 and GDIP1-T20.

W (R-GDFP-F20)

CERAMIC DUAL FLATPACK

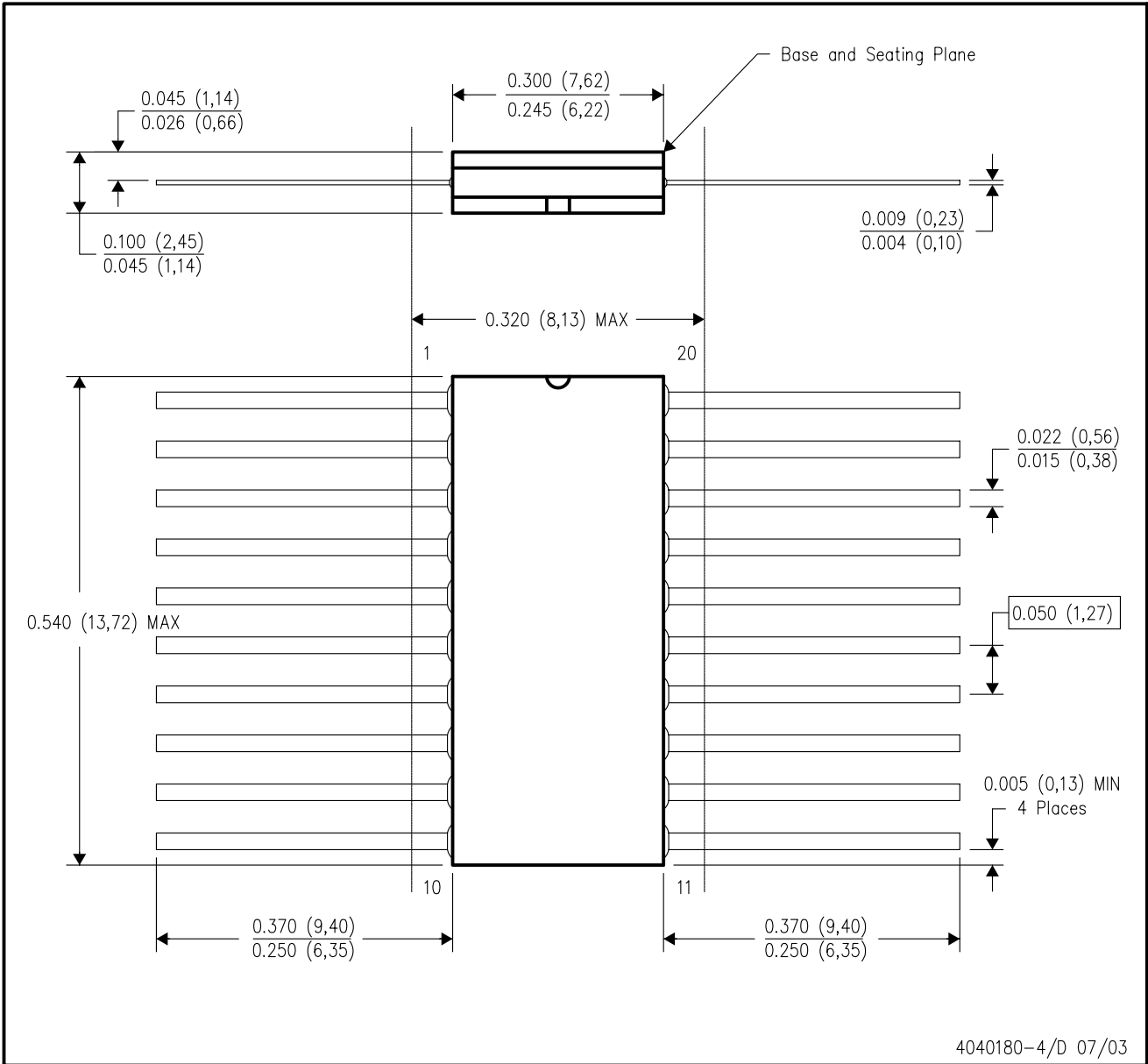

- NOTES:
- A. All linear dimensions are in inches (millimeters).
 - B. This drawing is subject to change without notice.
 - C. This package can be hermetically sealed with a ceramic lid using glass frit.
 - D. Index point is provided on cap for terminal identification only.
 - E. Falls within Mil-Std 1835 GDFP2-F20

FN (S-PQCC-J**)

PLASTIC J-LEADED CHIP CARRIER

20 PIN SHOWN

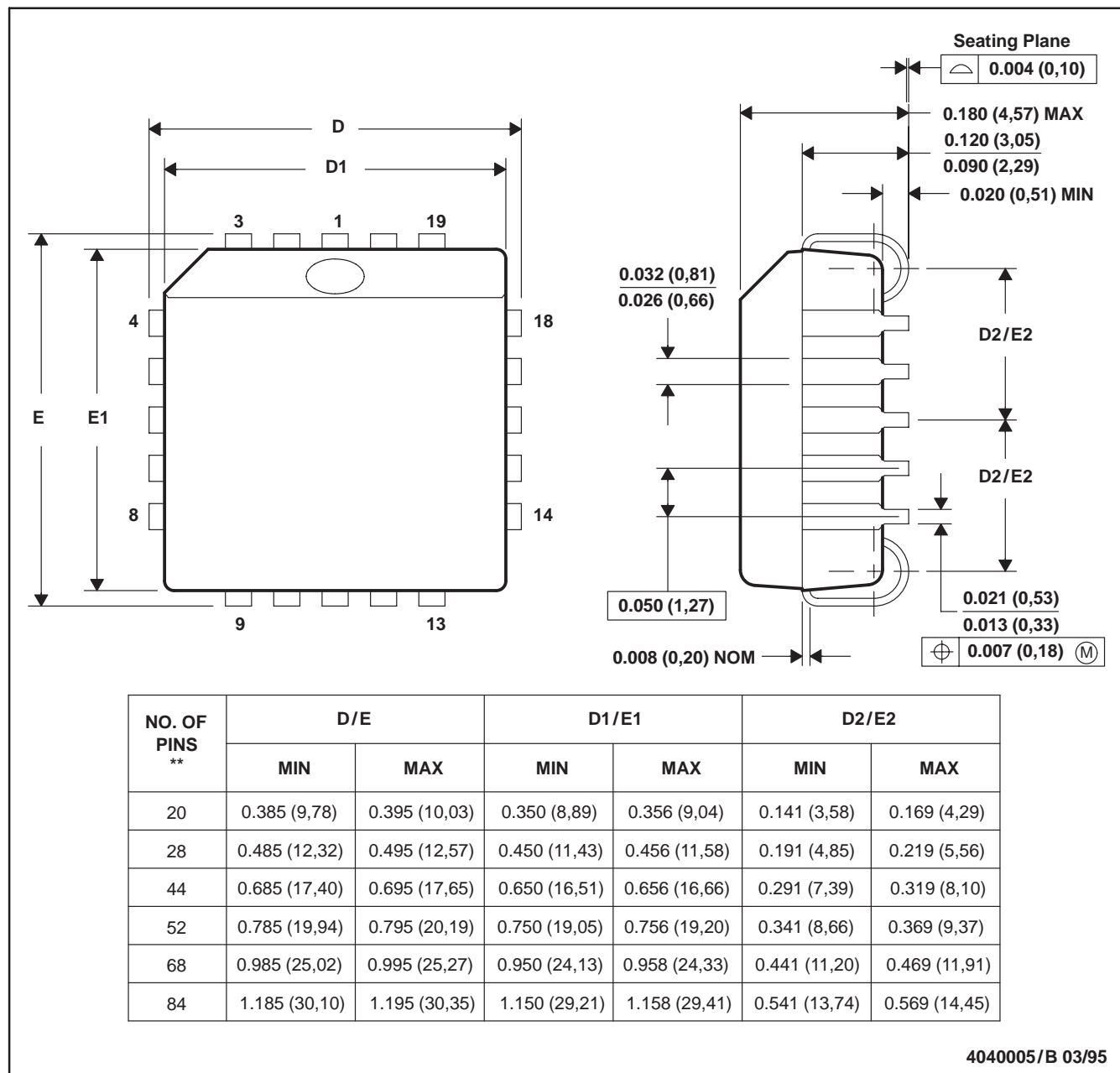

- NOTES: A. All linear dimensions are in inches (millimeters).
 B. This drawing is subject to change without notice.
 C. Falls within JEDEC MS-018

N (R-PDIP-T**)

PLASTIC DUAL-IN-LINE PACKAGE

16 PINS SHOWN



- NOTES:
- A. All linear dimensions are in inches (millimeters).
 - B. This drawing is subject to change without notice.
 - Falls within JEDEC MS-001, except 18 and 20 pin minimum body length (Dim A).
 - The 20 pin end lead shoulder width is a vendor option, either half or full width.

IMPORTANT NOTICE

Texas Instruments Incorporated and its subsidiaries (TI) reserve the right to make corrections, modifications, enhancements, improvements, and other changes to its products and services at any time and to discontinue any product or service without notice. Customers should obtain the latest relevant information before placing orders and should verify that such information is current and complete. All products are sold subject to TI's terms and conditions of sale supplied at the time of order acknowledgment.

TI warrants performance of its hardware products to the specifications applicable at the time of sale in accordance with TI's standard warranty. Testing and other quality control techniques are used to the extent TI deems necessary to support this warranty. Except where mandated by government requirements, testing of all parameters of each product is not necessarily performed.

TI assumes no liability for applications assistance or customer product design. Customers are responsible for their products and applications using TI components. To minimize the risks associated with customer products and applications, customers should provide adequate design and operating safeguards.

TI does not warrant or represent that any license, either express or implied, is granted under any TI patent right, copyright, mask work right, or other TI intellectual property right relating to any combination, machine, or process in which TI products or services are used. Information published by TI regarding third-party products or services does not constitute a license from TI to use such products or services or a warranty or endorsement thereof. Use of such information may require a license from a third party under the patents or other intellectual property of the third party, or a license from TI under the patents or other intellectual property of TI.

Reproduction of TI information in TI data books or data sheets is permissible only if reproduction is without alteration and is accompanied by all associated warranties, conditions, limitations, and notices. Reproduction of this information with alteration is an unfair and deceptive business practice. TI is not responsible or liable for such altered documentation. Information of third parties may be subject to additional restrictions.

Resale of TI products or services with statements different from or beyond the parameters stated by TI for that product or service voids all express and any implied warranties for the associated TI product or service and is an unfair and deceptive business practice. TI is not responsible or liable for any such statements.

TI products are not authorized for use in safety-critical applications (such as life support) where a failure of the TI product would reasonably be expected to cause severe personal injury or death, unless officers of the parties have executed an agreement specifically governing such use. Buyers represent that they have all necessary expertise in the safety and regulatory ramifications of their applications, and acknowledge and agree that they are solely responsible for all legal, regulatory and safety-related requirements concerning their products and any use of TI products in such safety-critical applications, notwithstanding any applications-related information or support that may be provided by TI. Further, Buyers must fully indemnify TI and its representatives against any damages arising out of the use of TI products in such safety-critical applications.

TI products are neither designed nor intended for use in military/aerospace applications or environments unless the TI products are specifically designated by TI as military-grade or "enhanced plastic." Only products designated by TI as military-grade meet military specifications. Buyers acknowledge and agree that any such use of TI products which TI has not designated as military-grade is solely at the Buyer's risk, and that they are solely responsible for compliance with all legal and regulatory requirements in connection with such use.

TI products are neither designed nor intended for use in automotive applications or environments unless the specific TI products are designated by TI as compliant with ISO/TS 16949 requirements. Buyers acknowledge and agree that, if they use any non-designated products in automotive applications, TI will not be responsible for any failure to meet such requirements.



Following are URLs where you can obtain information on other Texas Instruments products and application solutions:

Products		Applications	
Amplifiers	amplifier.ti.com	Audio	www.ti.com/audio
Data Converters	dataconverter.ti.com	Automotive	www.ti.com/automotive
DLP® Products	www.dlp.com	Communications and Telecom	www.ti.com/communications
DSP	dsp.ti.com	Computers and Peripherals	www.ti.com/computers
Clocks and Timers	www.ti.com/clocks	Consumer Electronics	www.ti.com/consumer-apps
Interface	interface.ti.com	Energy	www.ti.com/energy
Logic	logic.ti.com	Industrial	www.ti.com/industrial
Power Mgmt	power.ti.com	Medical	www.ti.com/medical
Microcontrollers	microcontroller.ti.com	Security	www.ti.com/security
RFID	www.ti-rfid.com	Space, Avionics & Defense	www.ti.com/space-avionics-defense
RF/IF and ZigBee® Solutions	www.ti.com/lprf	Video and Imaging	www.ti.com/video
		Wireless	www.ti.com/wireless-apps

Mailing Address: Texas Instruments, Post Office Box 655303, Dallas, Texas 75265
Copyright © 2010, Texas Instruments Incorporated

Looking for pricing, stock, or lifecycle information?

Click below to explore more details on WIN SOURCE:

-  [View TIBPAL16R6-5CN on WIN SOURCE](#)
-  [Texas Instruments](#) Information

Optimize Your Supply Chain with WIN SOURCE Solutions

-  Global Sourcing Solution
-  Obsolete Management
-  Cost Control Management
-  Shortage Management
-  Alternative Solution
-  Excess Inventory Management