

SN65LBC180-Q1

LOW-POWER DIFFERENTIAL LINE DRIVER AND RECEIVER PAIR

SGLS251A – JULY 2004 – REVISED JUNE 2008

- **Qualified for Automotive Applications**
- **Designed for High-Speed Multipoint Data Transmission Over Long Cables**
- **Operate With Pulse Durations as Low as 30 ns**
- **Low Supply Current . . . 5 mA Max**
- **Meet or Exceed the Requirements of ANSI Standard RS-485 and ISO 8482:1987(E)**
- **3-State Outputs for Party-Line Buses**
- **Common-Mode Voltage Range of -7 V to 12 V**
- **Thermal Shutdown Protection Prevents Driver Damage From Bus Contention**
- **Positive and Negative Output Current Limiting**
- **Pin Compatible With the SN75ALS180**

description

The SN65LBC180 differential driver and receiver pair is a monolithic integrated circuit designed for bidirectional data communication over long cables that take on the characteristics of transmission lines. It is a balanced, or differential, voltage mode device that meets or exceeds the requirements of industry standards ANSI RS-485 and ISO 8482:1987(E). The device is designed using TI's proprietary LinBiCMOS™ with the low power consumption of CMOS and the precision and robustness of bipolar transistors in the same circuit.

The SN65LBC180 combines a differential line driver and receiver with 3-state outputs and operates from a single 5-V supply. The driver and receiver have active-high and active-low enables, respectively, which can be externally connected to function as a direction control. The driver differential outputs and the receiver differential inputs are connected to separate terminals for full-duplex operation and are designed to present minimum loading to the bus whether disabled or powered off ($V_{CC} = 0$). This part features a wide common-mode voltage range making it suitable for point-to-point or multipoint data-bus applications.

**D PACKAGE
(TOP VIEW)**

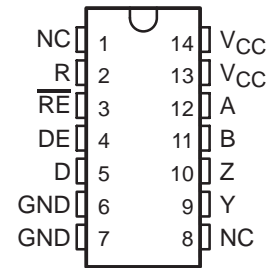

NC—No internal connection

Function Tables

DRIVER

INPUT D	ENABLE DE	OUTPUTS	
		Y	Z
H	H	H	L
L	H	L	H
X	L	Z	Z

RECEIVER

DIFFERENTIAL INPUTS A-B	ENABLE \overline{RE}	OUTPUT R
$V_{ID} \geq 0.2 V$	L	H
$-0.2 V < V_{ID} < 0.2 V$	L	?
$V_{ID} \leq -0.2 V$	L	L
X	H	Z
Open circuit	L	H

H = high level, L = low level, ? = indeterminate, X = irrelevant, Z = high impedance (off)

logic diagram (positive logic)

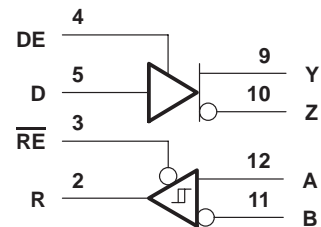

Please be aware that an important notice concerning availability, standard warranty, and use in critical applications of Texas Instruments semiconductor products and disclaimers thereto appears at the end of this data sheet.

LinBiCMOS is a trademark of Texas Instruments Incorporated.

PRODUCTION DATA information is current as of publication date. Products conform to specifications per the terms of Texas Instruments standard warranty. Production processing does not necessarily include testing of all parameters.



POST OFFICE BOX 655303 • DALLAS, TEXAS 75265

Copyright © 2008 Texas Instruments Incorporated

SN65LBC180-Q1

LOW-POWER DIFFERENTIAL LINE DRIVER AND RECEIVER PAIR

SGLS251A – JULY 2004 – REVISED JUNE 2008

description/ordering information (continued)

ORDERING INFORMATION†

TA	PACKAGE‡		ORDERABLE PART NUMBER	TOP-SIDE MARKING
-40°C to 85°C	SOIC – D	Tape and reel	SN65LBC180IDRQ1	LBC180Q1

† For the most current package and ordering information, see the Package Option Addendum at the end of this document, or see the TI web site at <http://www.ti.com>.

‡ Package drawings, thermal data, and symbolization are available at <http://www.ti.com/packaging>.

The devices also provide positive and negative output-current limiting and thermal shutdown for protection from line fault conditions. The line driver shuts down at a junction temperature of approximately 172°C.



POST OFFICE BOX 655303 • DALLAS, TEXAS 75265

SN65LBC180-Q1 LOW-POWER DIFFERENTIAL LINE DRIVER AND RECEIVER PAIR

SGLS251A – JULY 2004 – REVISED JUNE 2008

schematics of inputs and outputs

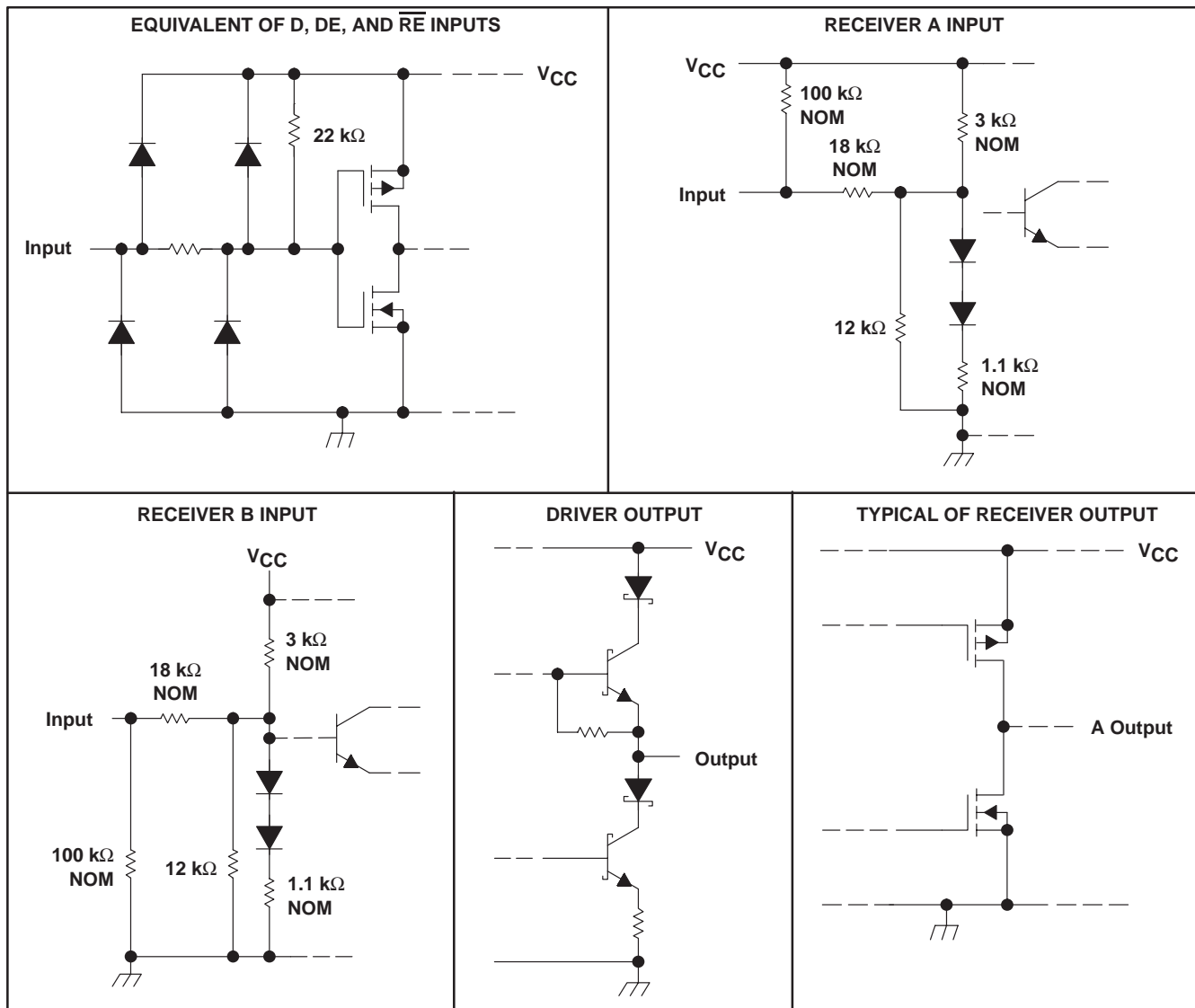

SN65LBC180-Q1

LOW-POWER DIFFERENTIAL LINE DRIVER AND RECEIVER PAIR

SGLS251A – JULY 2004 – REVISED JUNE 2008

absolute maximum ratings over operating free-air temperature range (unless otherwise noted)[†]

Supply voltage range, V_{CC} (see Note 1)	–0.3 V to 7 V
Input voltage range, V_I (A, B)(see Note 1)	–10 V to 15 V
Voltage range at D, R, DE, \overline{RE} (see Note 1)	–0.3 V to $V_{CC} + 0.5$ V
Continuous total power dissipation (see Note 2)	Internally limited
Total power dissipation	See Dissipation Rating Table
Operating free-air temperature range, T_A	–40°C to 85°C
Storage temperature range, T_{stg}	–65°C to 150°C
Lead temperature 1,6 mm (1/16 inch) from case for 10 seconds	260°C

[†] Stresses beyond those listed under “absolute maximum ratings” may cause permanent damage to the device. These are stress ratings only, and functional operation of the device at these or any other conditions beyond those indicated under “recommended operating conditions” is not implied. Exposure to absolute-maximum-rated conditions for extended periods may affect device reliability.

- NOTES: 1. All voltage values are with respect to GND.
 2. The maximum operating junction temperature is internally limited. Use the dissipation rating table to operate below this temperature.

DISSIPATION RATING TABLE

PACKAGE	$T_A \leq 25^\circ\text{C}$ POWER RATING	DERATING FACTOR ABOVE $T_A = 25^\circ\text{C}$	$T_A = 70^\circ\text{C}$ POWER RATING	$T_A = 85^\circ\text{C}$ POWER RATING
D	950 mW	7.6 mW/°C	608 mW	494 mW

recommended operating conditions

		MIN	NOM	MAX	UNIT
Supply voltage, V_{CC}		4.75	5	5.25	V
High-level input voltage, V_{IH}	D, DE, and \overline{RE}	2			V
Low-level input voltage, V_{IL}	D, DE, and \overline{RE}			0.8	V
Differential input voltage, V_{ID}		–6 [‡]		6	V
Voltage at any bus terminal (separately or common mode), V_O , V_I , or V_{IC}	A, B, Y, or Z	–7 [‡]		12	V
High-level output current, I_{OH}	Y or Z			–60	mA
	R			–8	
Low-level output current, I_{OL}	Y or Z			60	mA
	R			8	
Operating free-air temperature, T_A		–40		85	°C

[‡] The algebraic convention where the least positive (more negative) limit is designated minimum, is used in this data sheet for the differential input voltage, voltage at any bus terminal, operating temperature, input threshold voltage, and common-mode output voltage.



SN65LBC180-Q1

LOW-POWER DIFFERENTIAL LINE DRIVER AND RECEIVER PAIR

SGLS251A – JULY 2004 – REVISED JUNE 2008

DRIVER SECTION

electrical characteristics over recommended operating conditions (unless otherwise noted)

PARAMETER		TEST CONDITIONS		MIN	TYP†	MAX	UNIT
V_{IK}	Input clamp voltage	$I_I = -18 \text{ mA}$				-1.5	V
$ V_{OD} $	Differential output voltage magnitude (see Note 3)	$R_L = 54 \Omega$,	See Figure 1	1.1	2.5	5	V
		$R_L = 60 \Omega$,	See Figure 2	1.1	2	5	
$\Delta V_{OD} $	Change in magnitude of differential output voltage (see Note 4)	See Figures 1 and 2				± 0.2	V
V_{OC}	Common-mode output voltage			1	2.5	3	V
$\Delta V_{OC} $	Change in magnitude of common-mode output voltage (see Note 4)	$R_L = 54 \Omega$,	See Figure 1			± 0.2	V
I_O	Output current with power off	$V_{CC} = 0$,	$V_O = -7 \text{ V to } 12 \text{ V}$			± 100	μA
I_{OZ}	High-impedance-state output current	$V_O = -7 \text{ V to } 12 \text{ V}$				± 100	μA
I_{IH}	High-level input current	$V_I = 2.4 \text{ V}$				-100	μA
I_{IL}	Low-level input current	$V_I = 0.4 \text{ V}$				-100	μA
I_{OS}	Short-circuit output current	$-7 \text{ V} \leq V_O \leq 12 \text{ V}$				± 250	mA
I_{CC}	Supply current	Receiver disabled	Outputs enabled			5	mA
			Outputs disabled			3	

† All typical values are at $V_{CC} = 5 \text{ V}$ and $T_A = 25^\circ\text{C}$.

- NOTES: 3. The minimum V_{OD} specification of the SN65LBC180 may not fully comply with ANSI RS-485 at operating temperatures below 0°C . System designers should take the possibly lower output signal into account in determining the maximum signal-transmission distance.
4. $\Delta|V_{OD}|$ and $\Delta|V_{OC}|$ are the changes in the steady-state magnitude of V_{OD} and V_{OC} , respectively, that occur when the input is changed from a high level to a low level.

switching characteristics, $V_{CC} = 5 \text{ V}$, $T_A = 25^\circ\text{C}$

PARAMETER		TEST CONDITIONS		MIN	TYP	MAX	UNIT
$t_{d(OD)}$	Differential output delay time	$R_L = 54 \Omega$,	See Figure 3	7	12	18	ns
$t_{t(OD)}$	Differential output transition time			5	10	20	ns
t_{PZH}	Output enable time to high level	$R_L = 110 \Omega$,	See Figure 4			35	ns
t_{PZL}	Output enable time to low level	$R_L = 110 \Omega$,	See Figure 5			35	ns
t_{PHZ}	Output disable time from high level	$R_L = 110 \Omega$,	See Figure 4			50	ns
t_{PLZ}	Output disable time from low level	$R_L = 110 \Omega$,	See Figure 5			35	ns

SN65LBC180-Q1

LOW-POWER DIFFERENTIAL LINE DRIVER AND RECEIVER PAIR

SGLS251A – JULY 2004 – REVISED JUNE 2008

RECEIVER SECTION

electrical characteristics over recommended operating conditions (unless otherwise noted)

PARAMETER		TEST CONDITIONS	MIN	TYP	MAX	UNIT
V_{IT+}	Positive-going input threshold voltage	$I_O = -8 \text{ mA}$			0.2	V
V_{IT-}	Negative-going input threshold voltage	$I_O = 8 \text{ mA}$	-0.2			V
V_{hys}	Hysteresis voltage ($V_{IT+} - V_{IT-}$)			45		mV
V_{IK}	Enable-input clamp voltage	$I_I = -18 \text{ mA}$			-1.5	V
V_{OH}	High-level output voltage	$V_{ID} = 200 \text{ mV}$, $I_{OH} = -8 \text{ mA}$	3.5	4.5		V
V_{OL}	Low-level output voltage	$V_{ID} = -200 \text{ mV}$, $I_{OL} = 8 \text{ mA}$	0.3	0.5		V
I_{OZ}	High-impedance-state output current	$V_O = 0 \text{ V to } V_{CC}$			± 20	μA
I_{IH}	High-level enable-input current	$V_{IH} = 2.4 \text{ V}$			-50	μA
I_{IL}	Low-level enable-input current	$V_{IL} = 0.4 \text{ V}$			-100	μA
I_I	Bus input current	$V_I = 12 \text{ V}$, $V_{CC} = 5 \text{ V}$, Other input at 0 V		0.7	1	mA
		$V_I = 12 \text{ V}$, $V_{CC} = 0 \text{ V}$, Other input at 0 V		0.8	1	
		$V_I = -7 \text{ V}$, $V_{CC} = 5 \text{ V}$, Other input at 0 V		-0.5	-0.8	
		$V_I = -7 \text{ V}$, $V_{CC} = 0 \text{ V}$, Other input at 0 V		-0.5	-0.8	
I_{CC}	Supply current	Driver disabled	Outputs enabled		5	mA
			Outputs disabled		3	

switching characteristics, $V_{CC} = 5 \text{ V}$, $T_A = 25^\circ\text{C}$

PARAMETER		TEST CONDITIONS	MIN	TYP	MAX	UNIT
t_{PHL}	Propagation delay time, high- to low-level output	$V_{ID} = -1.5 \text{ V to } 1.5 \text{ V}$, See Figure 6	11	22	33	ns
t_{PLH}	Propagation delay time, low- to high-level output		11	22	33	ns
$t_{sk(p)}$	Pulse skew ($ t_{PHL} - t_{PLH} $)		3	6		ns
t_t	Transition time		5	8		ns
t_{PZH}	Output enable time to high level	See Figure 7			35	ns
t_{PZL}	Output enable time to low level				30	ns
t_{PHZ}	Output disable time from high level				35	ns
t_{PLZ}	Output disable time from low level				30	ns



PARAMETER MEASUREMENT INFORMATION

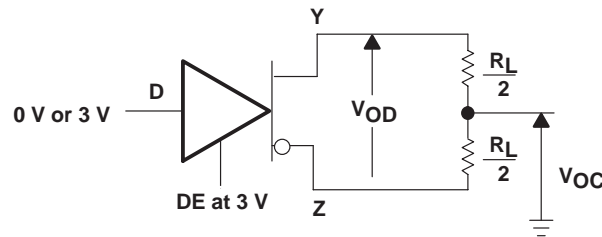

Figure 1. Differential and Common-Mode Output Voltages

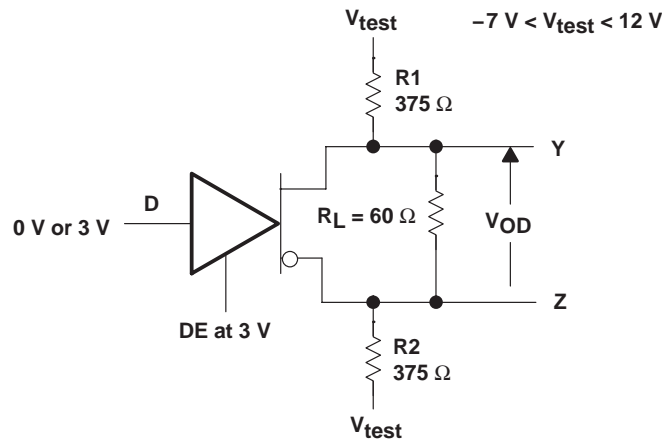
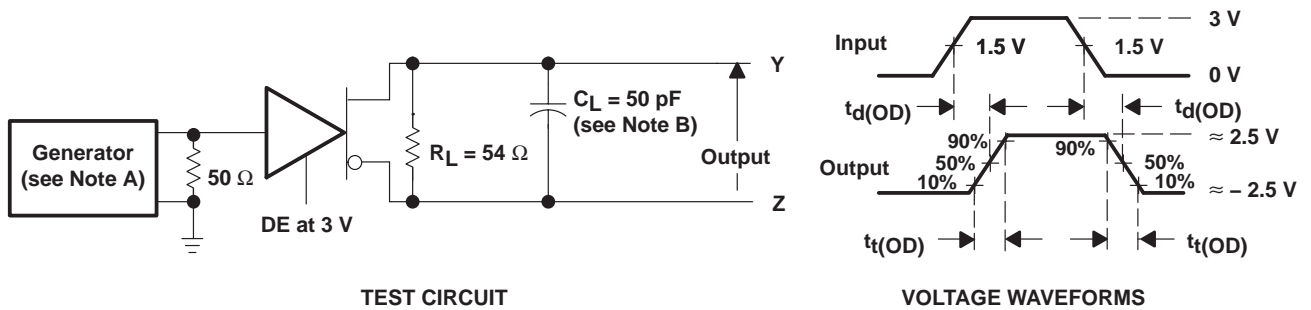

Figure 2. Driver V_{OD} Test Circuit



- NOTES: A. The input pulse is supplied by a generator having the following characteristics: PRR > 1 MHz, 50% duty cycle, $t_r \leq 6$ ns, $t_f \leq 6$ ns, $Z_O = 50 \Omega$.
 B. C_L includes probe and jig capacitance.

Figure 3. Driver Test Circuit and Differential Output Delay and Transition Time Voltage Waveforms

SN65LBC180-Q1

LOW-POWER DIFFERENTIAL LINE DRIVER AND RECEIVER PAIR

SGLS251A – JULY 2004 – REVISED JUNE 2008

PARAMETER MEASUREMENT INFORMATION

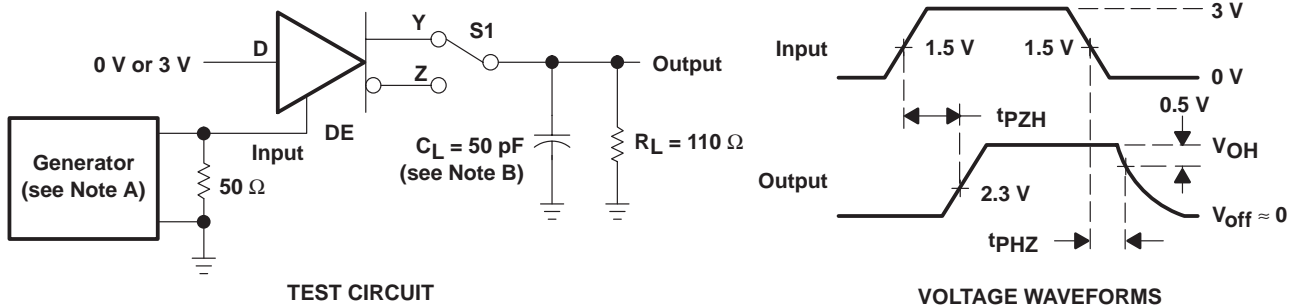

Figure 4. Driver Test Circuit and Enable and Disable Time Waveforms

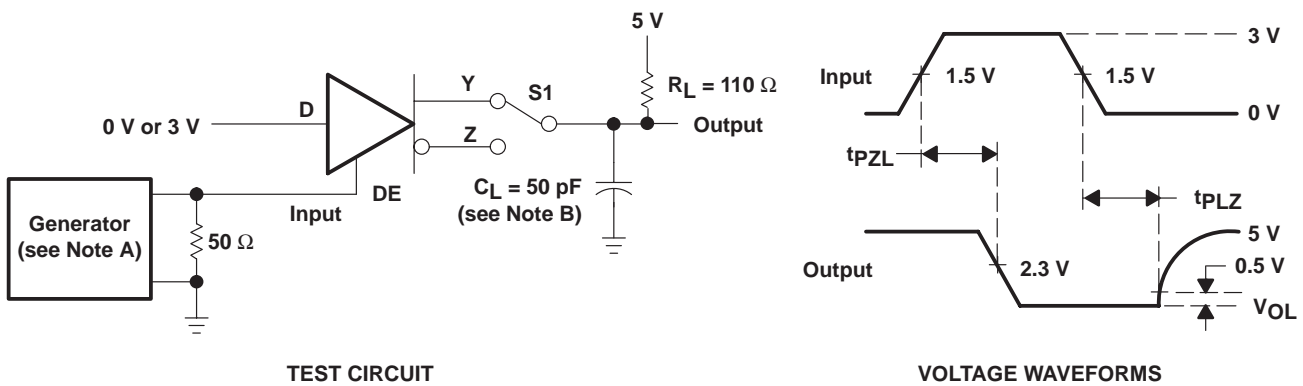
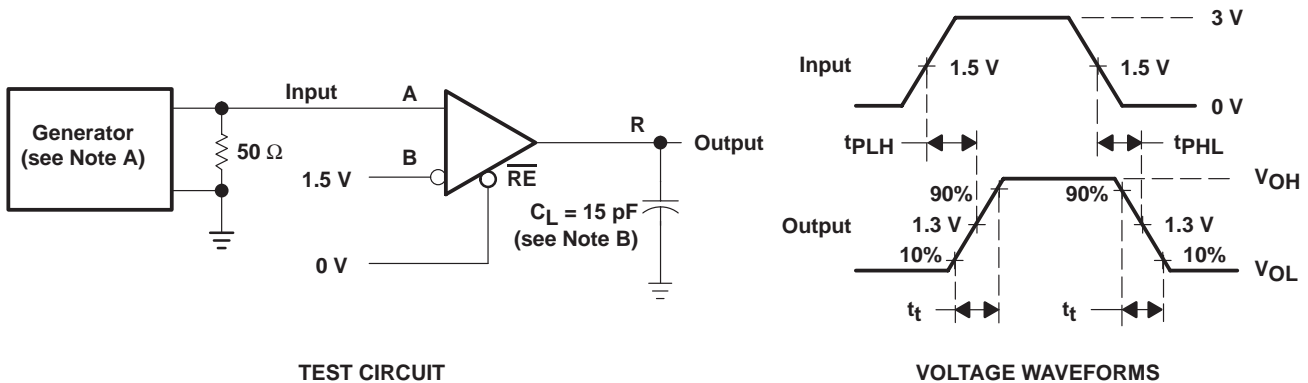

Figure 5. Driver Test Circuit and Enable and Disable Time Voltage Waveforms



- NOTES: A. The input pulse is supplied by a generator having the following characteristics: $PRR \leq 1 \text{ MHz}$, 50% duty cycle, $t_r \leq 6 \text{ ns}$, $t_f \leq 6 \text{ ns}$, $Z_0 = 50 \Omega$.
- B. C_L includes probe and jig capacitance.

Figure 6. Receiver Test Circuit and Propagation Delay Time Voltage Waveforms

SN65LBC180-Q1

LOW-POWER DIFFERENTIAL LINE DRIVER AND RECEIVER PAIR

SGLS251A – JULY 2004 – REVISED JUNE 2008

PARAMETER MEASUREMENT INFORMATION

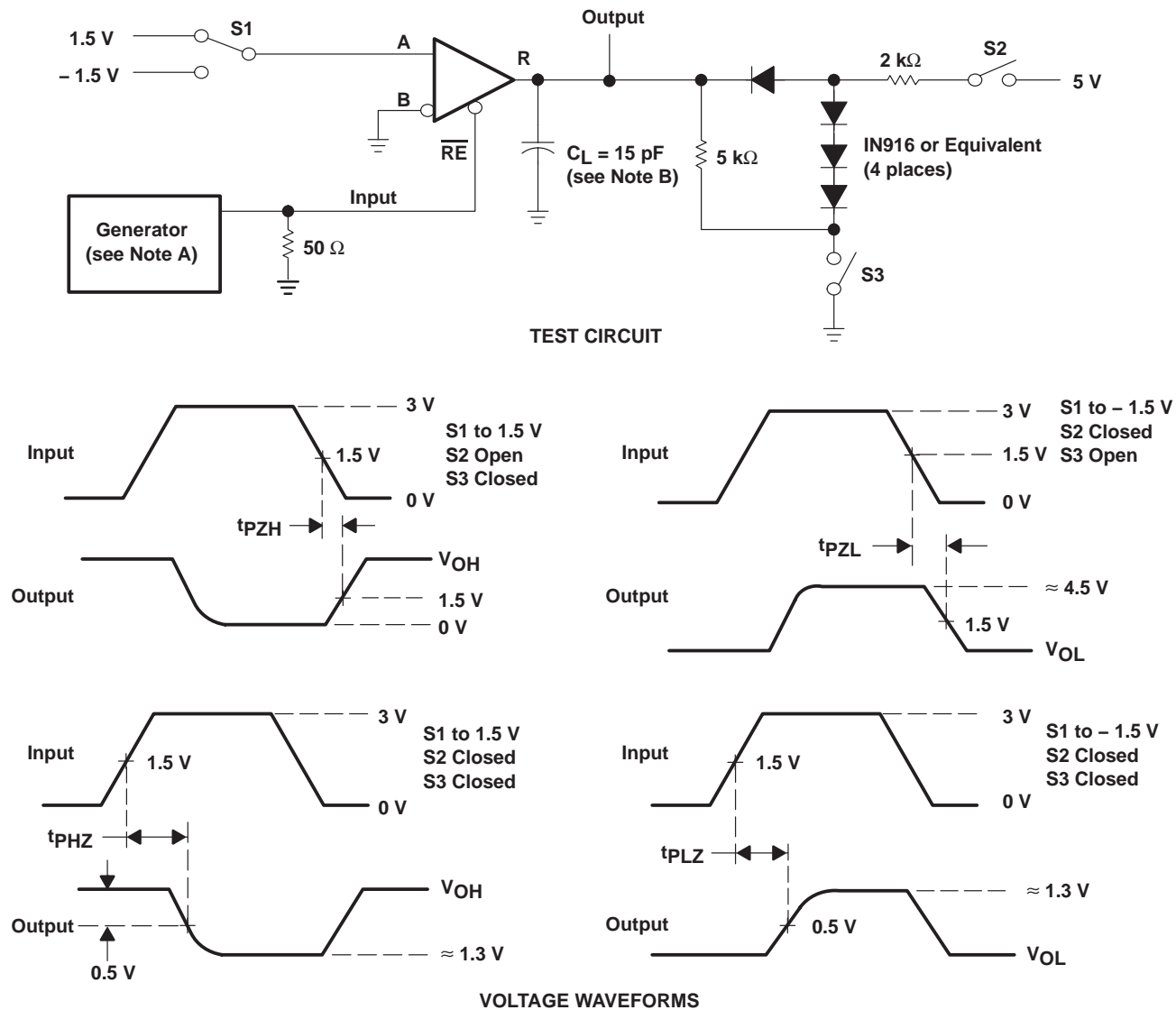

- NOTES: A. The input pulse is supplied by a generator having the following characteristics: $PRR \leq 1$ MHz, 50% duty cycle, $t_r \leq 6$ ns, $t_f \leq 6$ ns, $Z_O = 50 \Omega$.
- B. C_L includes probe and jig capacitance.

Figure 7. Receiver Output Enable and Disable Times

SN65LBC180-Q1

LOW-POWER DIFFERENTIAL LINE DRIVER AND RECEIVER PAIR

SGLS251A – JULY 2004 – REVISED JUNE 2008

TYPICAL CHARACTERISTICS

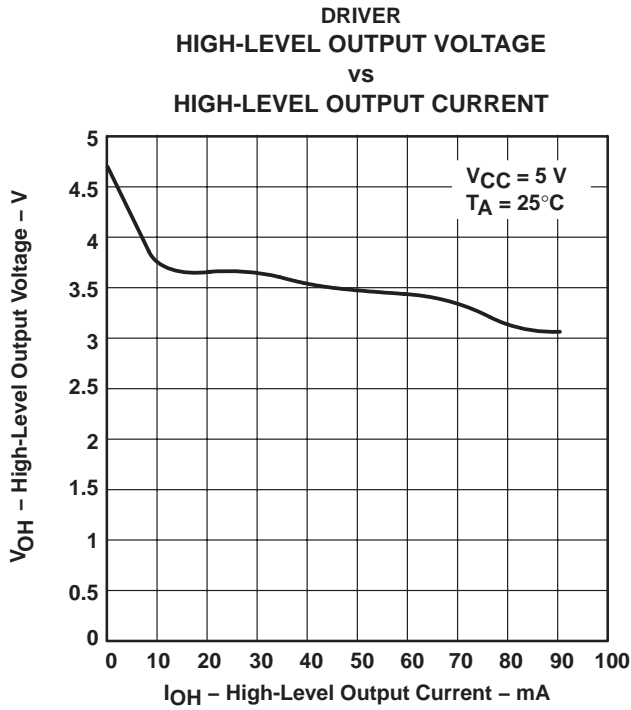

Figure 8

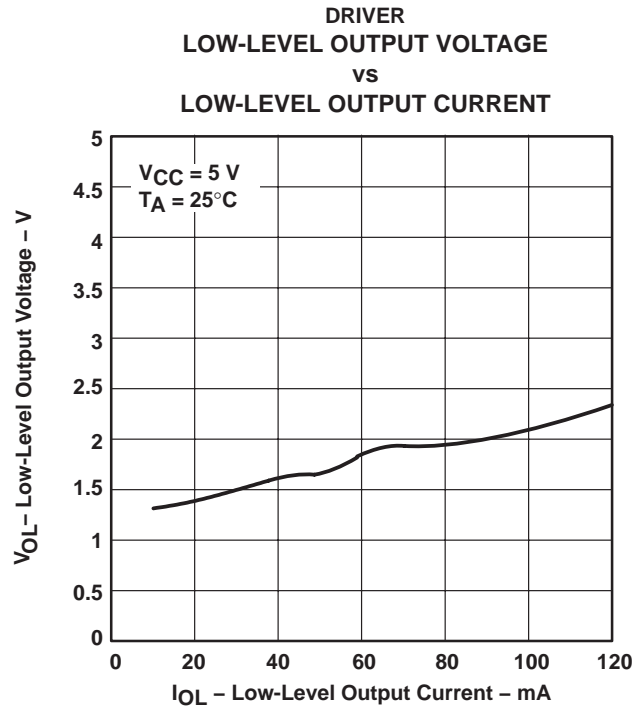

Figure 9

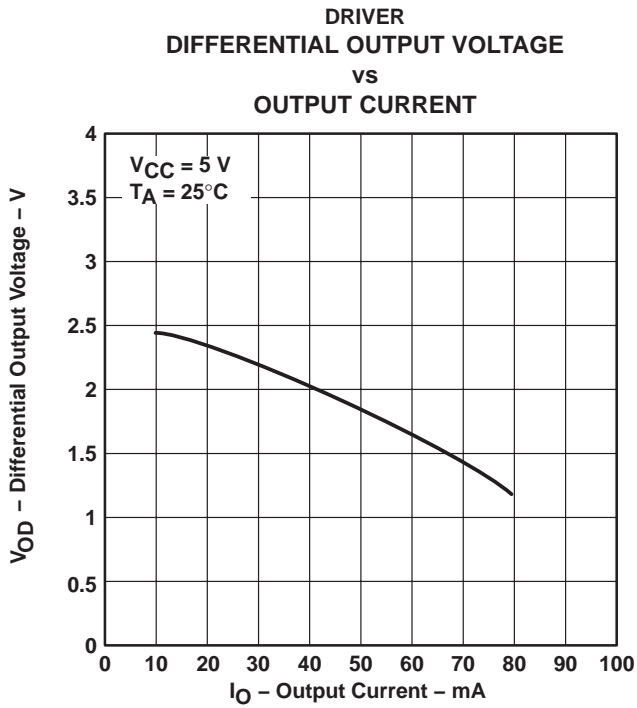

Figure 10

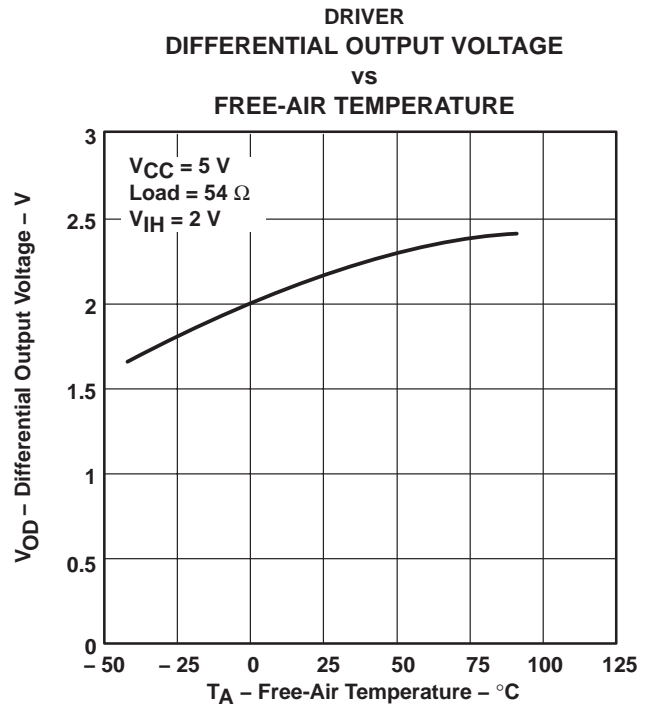

Figure 11



SN65LBC180-Q1

LOW-POWER DIFFERENTIAL LINE DRIVER AND RECEIVER PAIR

SGLS251A – JULY 2004 – REVISED JUNE 2008

TYPICAL CHARACTERISTICS

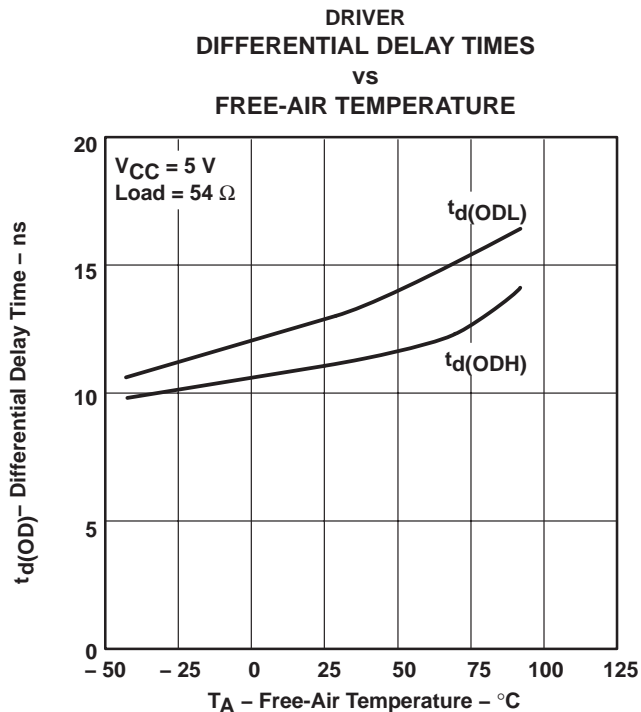

Figure 12

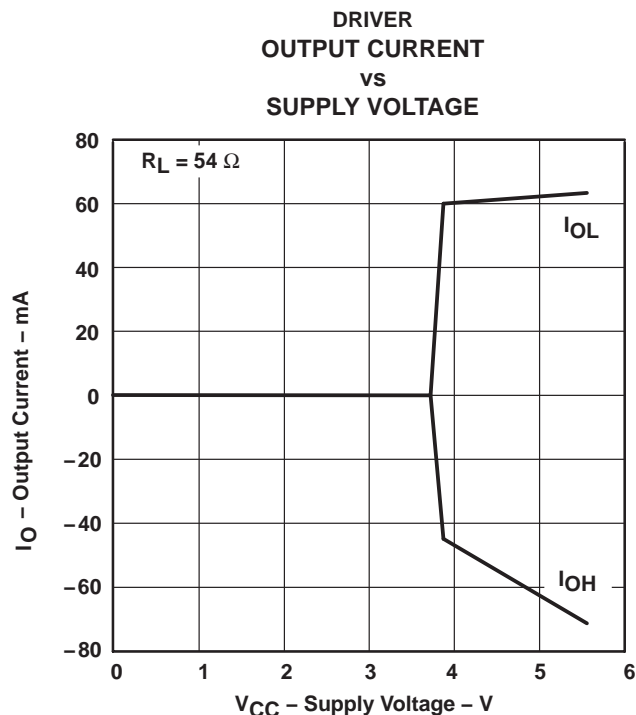

Figure 13

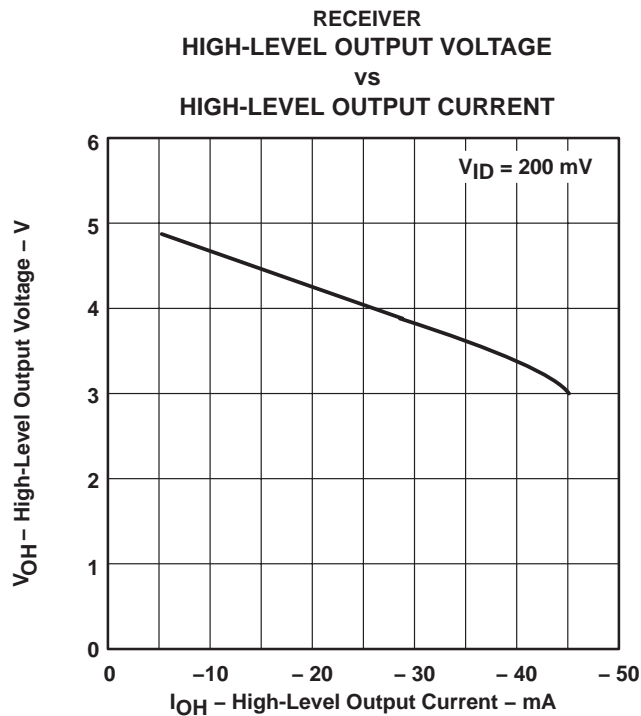

Figure 14

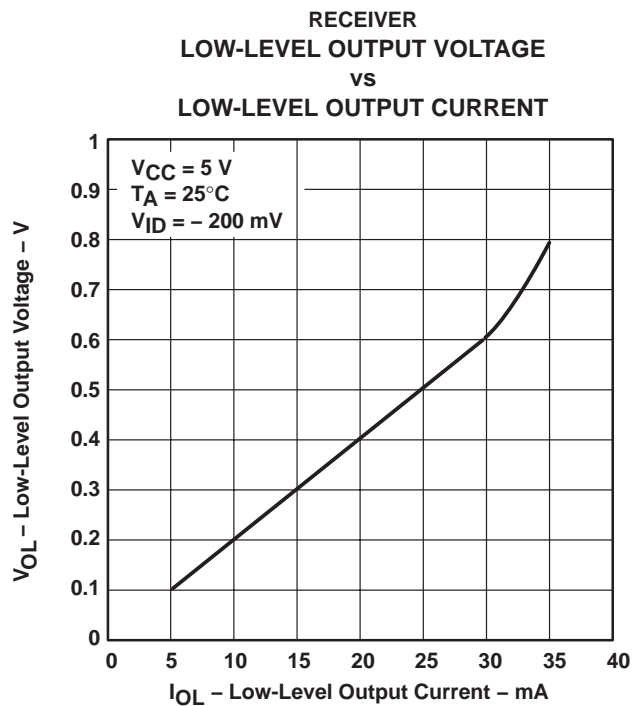

Figure 15

SN65LBC180-Q1

LOW-POWER DIFFERENTIAL LINE DRIVER AND RECEIVER PAIR

SGLS251A – JULY 2004 – REVISED JUNE 2008

TYPICAL CHARACTERISTICS

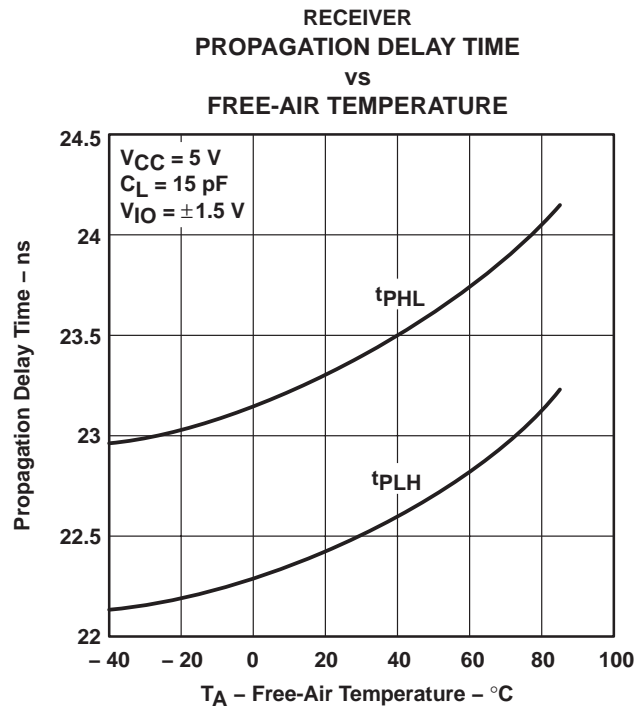
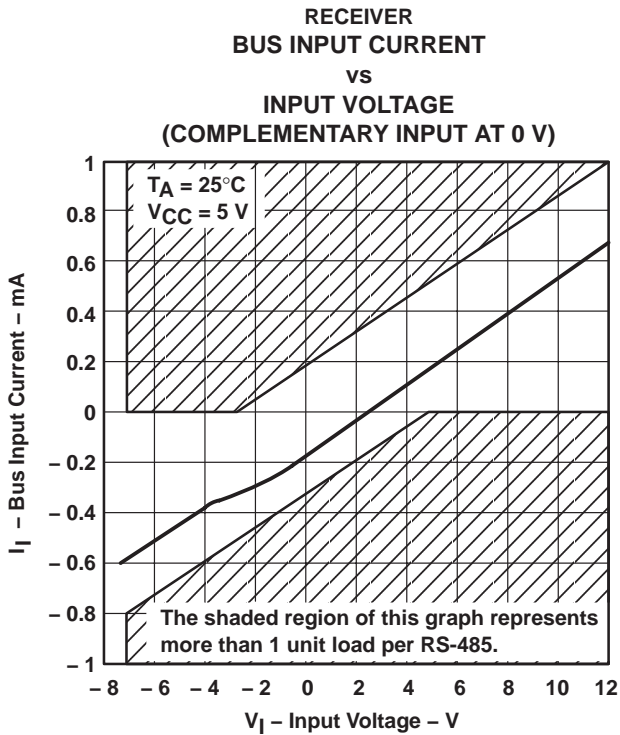
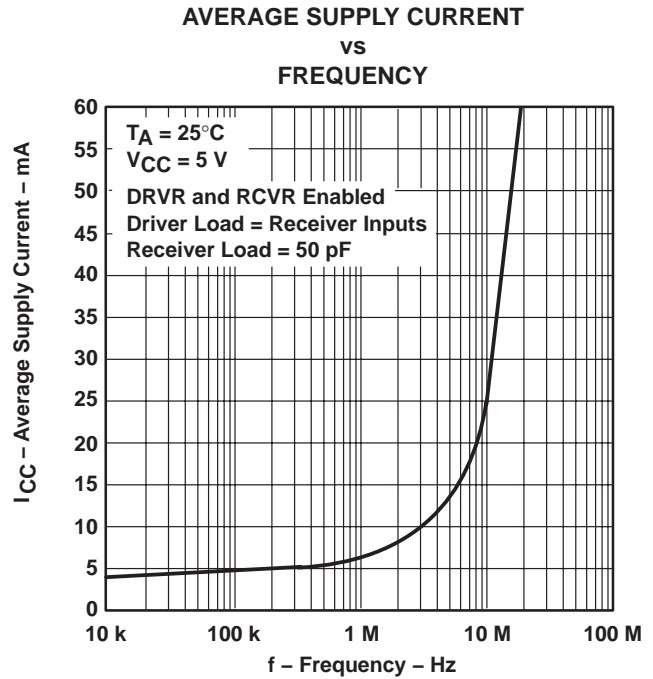
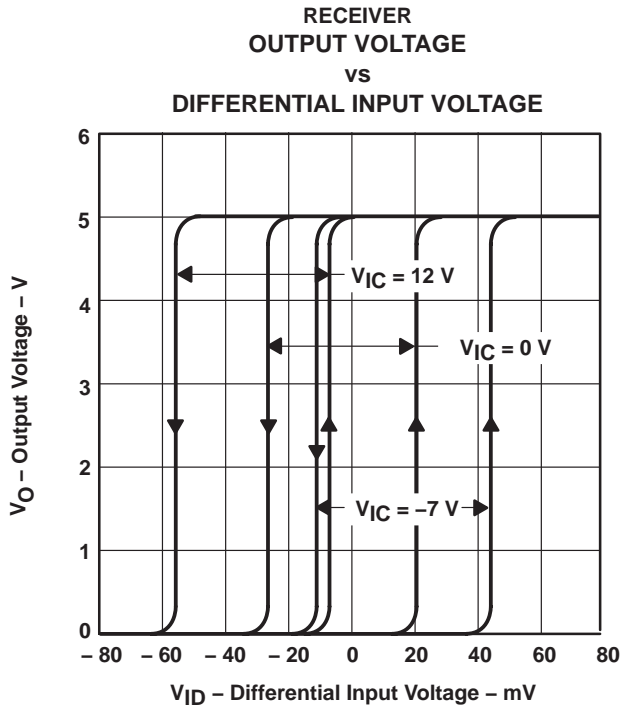

APPLICATION INFORMATION

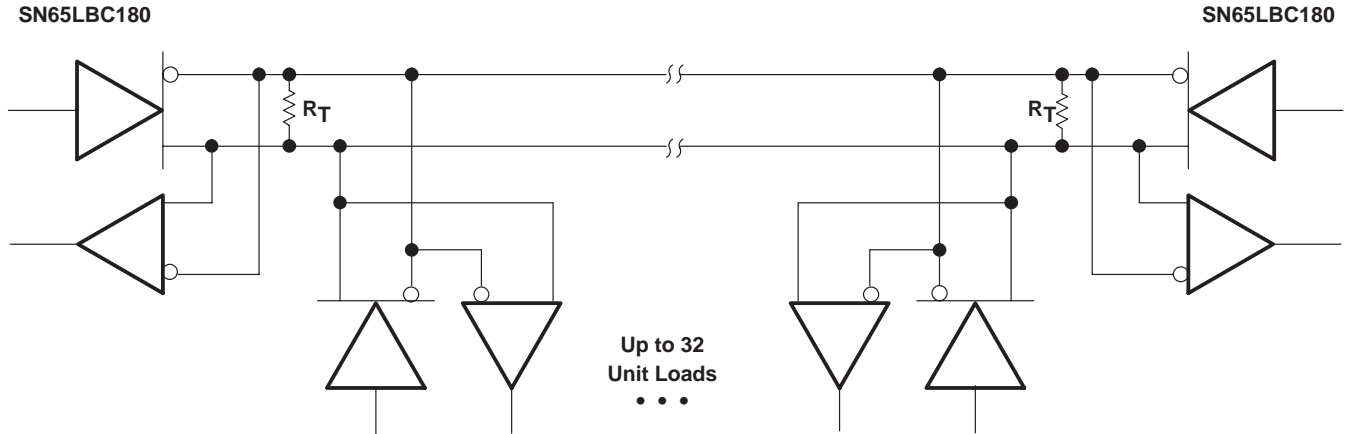

NOTE A: The line should be terminated at both ends in its characteristic impedance ($R_T = Z_0$). Stub lengths off the main line should be kept as short as possible. One SN65LBC180 typically represents less than one unit load.

Figure 20. Typical Application Circuit

PACKAGING INFORMATION

Orderable Device	Status (1)	Package Type	Package Drawing	Pins	Package Qty	Eco Plan (2)	Lead/Ball Finish	MSL Peak Temp (3)	Op Temp (°C)	Top-Side Markings (4)	Samples
SN65LBC180IDRG4Q1	ACTIVE	SOIC	D	14	2500	Green (RoHS & no Sb/Br)	CU NIPDAU	Level-1-260C-UNLIM	-40 to 85	BL180Q1	Samples
SN65LBC180IDRQ1	ACTIVE	SOIC	D	14	2500	Green (RoHS & no Sb/Br)	CU NIPDAU	Level-1-260C-UNLIM	-40 to 85	LBC180IQ1	Samples

(1) The marketing status values are defined as follows:

ACTIVE: Product device recommended for new designs.

LIFEBUY: TI has announced that the device will be discontinued, and a lifetime-buy period is in effect.

NRND: Not recommended for new designs. Device is in production to support existing customers, but TI does not recommend using this part in a new design.

PREVIEW: Device has been announced but is not in production. Samples may or may not be available.

OBSOLETE: TI has discontinued the production of the device.

(2) Eco Plan - The planned eco-friendly classification: Pb-Free (RoHS), Pb-Free (RoHS Exempt), or Green (RoHS & no Sb/Br) - please check <http://www.ti.com/productcontent> for the latest availability information and additional product content details.

TBD: The Pb-Free/Green conversion plan has not been defined.

Pb-Free (RoHS): TI's terms "Lead-Free" or "Pb-Free" mean semiconductor products that are compatible with the current RoHS requirements for all 6 substances, including the requirement that lead not exceed 0.1% by weight in homogeneous materials. Where designed to be soldered at high temperatures, TI Pb-Free products are suitable for use in specified lead-free processes.

Pb-Free (RoHS Exempt): This component has a RoHS exemption for either 1) lead-based flip-chip solder bumps used between the die and package, or 2) lead-based die adhesive used between the die and leadframe. The component is otherwise considered Pb-Free (RoHS compatible) as defined above.

Green (RoHS & no Sb/Br): TI defines "Green" to mean Pb-Free (RoHS compatible), and free of Bromine (Br) and Antimony (Sb) based flame retardants (Br or Sb do not exceed 0.1% by weight in homogeneous material)

(3) MSL, Peak Temp. -- The Moisture Sensitivity Level rating according to the JEDEC industry standard classifications, and peak solder temperature.

(4) Multiple Top-Side Markings will be inside parentheses. Only one Top-Side Marking contained in parentheses and separated by a "~" will appear on a device. If a line is indented then it is a continuation of the previous line and the two combined represent the entire Top-Side Marking for that device.

Important Information and Disclaimer: The information provided on this page represents TI's knowledge and belief as of the date that it is provided. TI bases its knowledge and belief on information provided by third parties, and makes no representation or warranty as to the accuracy of such information. Efforts are underway to better integrate information from third parties. TI has taken and continues to take reasonable steps to provide representative and accurate information but may not have conducted destructive testing or chemical analysis on incoming materials and chemicals. TI and TI suppliers consider certain information to be proprietary, and thus CAS numbers and other limited information may not be available for release.

In no event shall TI's liability arising out of such information exceed the total purchase price of the TI part(s) at issue in this document sold by TI to Customer on an annual basis.

OTHER QUALIFIED VERSIONS OF SN65LBC180-Q1 :

- Catalog: [SN65LBC180](#)

NOTE: Qualified Version Definitions:

- Catalog - TI's standard catalog product

TAPE AND REEL BOX DIMENSIONS



*All dimensions are nominal

Device	Package Type	Package Drawing	Pins	SPQ	Length (mm)	Width (mm)	Height (mm)
SN65LBC180IDRG4Q1	SOIC	D	14	2500	350.0	350.0	43.0

D (R-PDSO-G14)

PLASTIC SMALL OUTLINE



- NOTES:
- A. All linear dimensions are in inches (millimeters).
 - B. This drawing is subject to change without notice.
 - Body length does not include mold flash, protrusions, or gate burrs. Mold flash, protrusions, or gate burrs shall not exceed 0.006 (0,15) each side.
 - Body width does not include interlead flash. Interlead flash shall not exceed 0.017 (0,43) each side.
 - E. Reference JEDEC MS-012 variation AB.

D (R-PDSO-G14)

PLASTIC SMALL OUTLINE



4211283-3/E 08/12

- NOTES:
- All linear dimensions are in millimeters.
 - This drawing is subject to change without notice.
 - Publication IPC-7351 is recommended for alternate designs.
 - Laser cutting apertures with trapezoidal walls and also rounding corners will offer better paste release. Customers should contact their board assembly site for stencil design recommendations. Refer to IPC-7525 for other stencil recommendations.
 - Customers should contact their board fabrication site for solder mask tolerances between and around signal pads.

IMPORTANT NOTICE AND DISCLAIMER

TI PROVIDES TECHNICAL AND RELIABILITY DATA (INCLUDING DATASHEETS), DESIGN RESOURCES (INCLUDING REFERENCE DESIGNS), APPLICATION OR OTHER DESIGN ADVICE, WEB TOOLS, SAFETY INFORMATION, AND OTHER RESOURCES "AS IS" AND WITH ALL FAULTS, AND DISCLAIMS ALL WARRANTIES, EXPRESS AND IMPLIED, INCLUDING WITHOUT LIMITATION ANY IMPLIED WARRANTIES OF MERCHANTABILITY, FITNESS FOR A PARTICULAR PURPOSE OR NON-INFRINGEMENT OF THIRD PARTY INTELLECTUAL PROPERTY RIGHTS.

These resources are intended for skilled developers designing with TI products. You are solely responsible for (1) selecting the appropriate TI products for your application, (2) designing, validating and testing your application, and (3) ensuring your application meets applicable standards, and any other safety, security, or other requirements. These resources are subject to change without notice. TI grants you permission to use these resources only for development of an application that uses the TI products described in the resource. Other reproduction and display of these resources is prohibited. No license is granted to any other TI intellectual property right or to any third party intellectual property right. TI disclaims responsibility for, and you will fully indemnify TI and its representatives against, any claims, damages, costs, losses, and liabilities arising out of your use of these resources.

TI's products are provided subject to TI's Terms of Sale (www.ti.com/legal/termsofsale.html) or other applicable terms available either on ti.com or provided in conjunction with such TI products. TI's provision of these resources does not expand or otherwise alter TI's applicable warranties or warranty disclaimers for TI products.

Mailing Address: Texas Instruments, Post Office Box 655303, Dallas, Texas 75265
Copyright © 2019, Texas Instruments Incorporated

Looking for pricing, stock, or lifecycle information?

Click below to explore more details on WIN SOURCE:

 [View SN65LBC180IDRQ1 on WIN SOURCE](#)

 [Texas Instruments](#) Information

Optimize Your Supply Chain with WIN SOURCE Solutions

-  Global Sourcing Solution
-  Obsolete Management
-  Cost Control Management
-  Shortage Management
-  Alternative Solution
-  Excess Inventory Management