

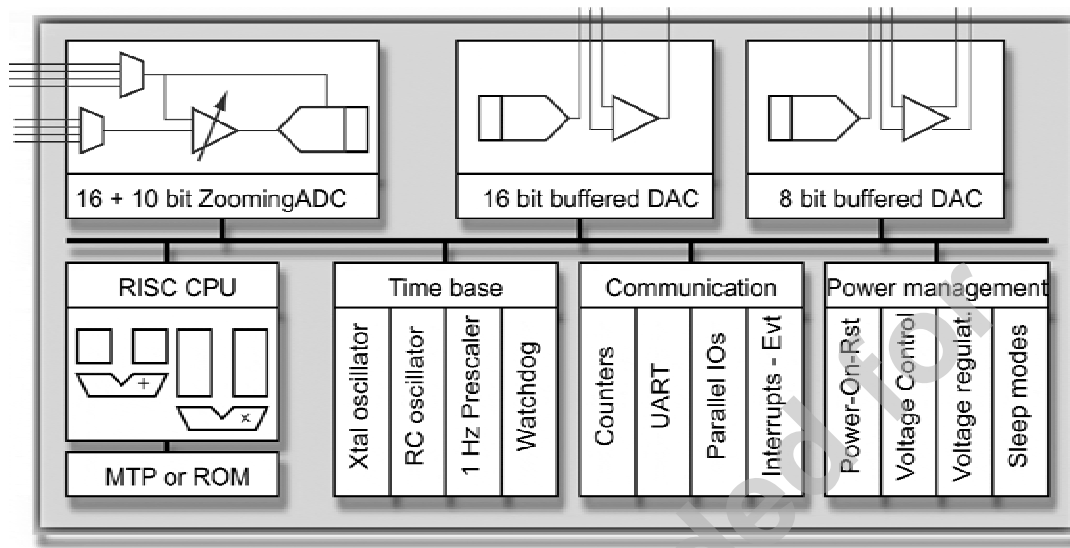

**THE DATASHEET OF
XE8805AMI028LF**





XE8805/05A – SX8805R Sensing Machine – Data Acquisition with 16+10 bit ZoomingADC™ and buffered DACs

General Description

The XE8805A is a data acquisition ultra low-power low-voltage system on a chip (SoC) with a high efficiency microcontroller unit embedded (MCU), allowing for 1 MIPS at 300uA and 2.4 V, and multiplying in one clock cycle.

The XE8805A includes a high resolution acquisition path with the 16+10 bits ZoomingADC and two buffered DACs.

The XE8805A is available with on chip ROM (the SX8805) or Multiple-Time-Programmable (MTP) program memory.

Applications

- Portable, battery operated instruments
- Current loop powered instruments
- Wheatstone bridge interfaces
- Pressure and chemical sensors
- HVAC control
- Metering
- Sports watches, wrist instruments

Key product Features

- Low-power, high resolution ZoomingADC
 - 0.5 to 1000 gain with offset cancellation
 - up to 16 bits analog to digital converter
 - up to 13 inputs multiplexer
- Low-voltage low-power controller operation
 - 2 MIPS with 2.4 V to 5.5 V operation
 - 300 µA at 1 MIPS over voltage range
- 22 kByte (8 kInstruction) MTP
- 520 Byte RAM data memory
- RC and crystal oscillators
- 5 reset, 22 interrupt, 8 event sources
- 8 bit and 16 bit buffered DACs
- 100 years MTP Flash retention at 55°C

Ordering Information

Product	Temperature range	Memory type	Package
XE8805MI028*	-40°C to 85 °C	MTP	LQFP64
XE8805AMI000	-40°C to 85 °C	MTP	die
XE8805AMI028LF	-40°C to 85 °C	MTP	LQFP64
SX8805Rxxx	-40°C to 85 °C**	ROM	

*Not for new designs

**Extended temperature range on request

TABLE OF CONTENTS

Chapter 1	XE8805/05A Overview
Chapter 2	XE8805/05A Performance
Chapter 3	XE8805/05A CPU
Chapter 4	XE8805/05A Memory
Chapter 5	System Block
Chapter 6	Reset generator
Chapter 7	Clock generation
Chapter 8	Interrupt handler
Chapter 9	Event handler
Chapter 10	Low power RAM
Chapter 11	Port A
Chapter 12	Port B
Chapter 13	Port C
Chapter 14	Universal Asynchronous Receiver/Transmitter (UART)
Chapter 15	Universal Synchronous Receiver/Transmitter (USRT)
Chapter 16	Acquisition Chain (ZoomingADC™)
Chapter 17	Voltage multiplier
Chapter 18	Signal D/A (DAS)
Chapter 19	Bias D/A (DAB)
Chapter 20	Counters/Timers/PWM
Chapter 21	The Voltage Level Detector
Chapter 22	XE8805/05A Dimensions

Not Recommended for
New Designs

1. General Overview

CONTENTS

1.1	Top schematic	1-2
1.1.1	General description	1-2
1.1.2	XE8805 vs XE8805A	1-4
1.2	Pin map	1-4
1.2.1	Bare die	1-4
1.2.2	LQFP-64	1-5
1.3	Pin assignment	1-6

Not Recommended for
New Designs

1.1 Top schematic

1.1.1 General description

The top level block schematic of the circuit is shown in Figure 1-1. The heart of the circuit consists of the Coolrisc816® CPU core. This core includes an 8x8 multiplier and 16 internal registers.

The bus controller generates all control signals for access to all data registers other than the CPU internal registers.

The reset block generates the adequate reset signals for the rest of the circuit as a function of the set-up contained in its control registers. Possible reset sources are the power-on-reset (POR), the external pin RESET, the watchdog (WD), a bus error detected by the bus controller or a programmable pattern on Port A. Different low power modes are implemented.

The clock generation and power management block sets up the clock signals and generates internal supplies for different blocks. The clock can be generated from the RC oscillator (this is the start-up condition), the crystal oscillator (XTAL) or an external clock source (given on the OSCIN pin).

The test controller generates all set-up signals for different test modes. In normal operation, it is used as a set of 8 low power data registers. If power consumption is important for the application, the variables that need to be accessed very often should be stored in these registers rather than in the RAM.

The IRQ handler routes the interrupt signals of the different peripherals to the IRQ inputs of the CPU core. It allows masking of the interrupt sources and it flags which interrupt source is active.

Events are generally used to restart the processor after a HALT period without jumping to a specified address, i.e. the program execution resumes with the instruction following the HALT instruction. The EVN handler routes the event signals of the different peripherals to the EVN inputs of the CPU core. It allows masking of the interrupt sources and it flags which interrupt source is active.

The Port B is an 8 bit parallel IO port with analog capabilities. The URST, UART, and PWM block also make use of this port.

The instruction memory is a 22-bit wide flash or ROM memory depending on the circuit version. Flash and ROM versions have both 8k instruction memory. The data memory of this product is 512 byte SRAM.

The Acquisition Chain is a high resolution acquisition path with the 16+10 bit fully differential ZoomingADC™. The VMULT (voltage multiplier) powers a part of the Acquisition Chain.

The signal D/A (DAS) is a 16 bit D/A based on sigma-delta modulation. It includes a stand-alone amplifier that can be used for analog output filtering.

The bias D/A (DAB) is an 8 bit low frequency D/A. It includes a stand-alone amplifier that is used to drive large currents. It can be used to bias a sensor.

The Port A is an 8 bit parallel input port. It can also generate interrupts, events or a reset. It can be used to input external clocks for the timer/counter/PWM block.

The Port C is a general purpose 8 bit parallel I/O port.

The USRT (universal synchronous receiver/transmitter) contains some simple hardware functions in order to simplify the software implementation of a synchronous serial link.

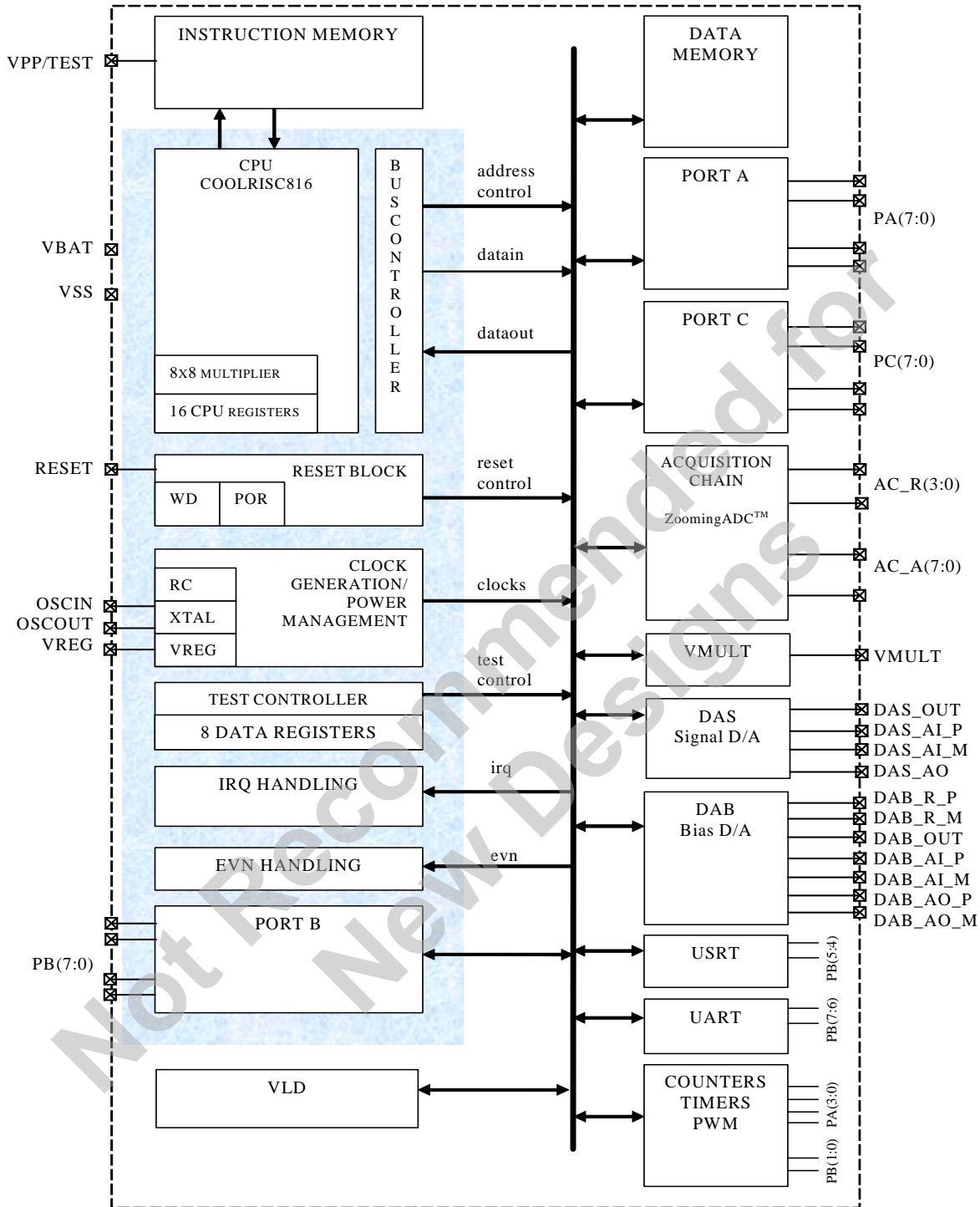

Figure 1-1. Block schematic of the XE8805/05A circuit.

The UART (universal asynchronous receiver/transmitter) contains a full hardware implementation of the asynchronous serial link.

The counters/timers/PWM can take their clocks from internal or external sources (on Port A) and can generate interrupts or events. The PWM is output on Port B.

The VLD (voltage level detector) detects the battery end of life with respect to a programmable threshold.

1.1.2 XE8805 vs XE8805A

The XE8805A has a new RESET pin function. The action of the RESET pin of the XE8805A resets the clock registers too and creates an additional short delay. See the RESET chapter for more information.

1.2 Pin map

1.2.1 Bare die

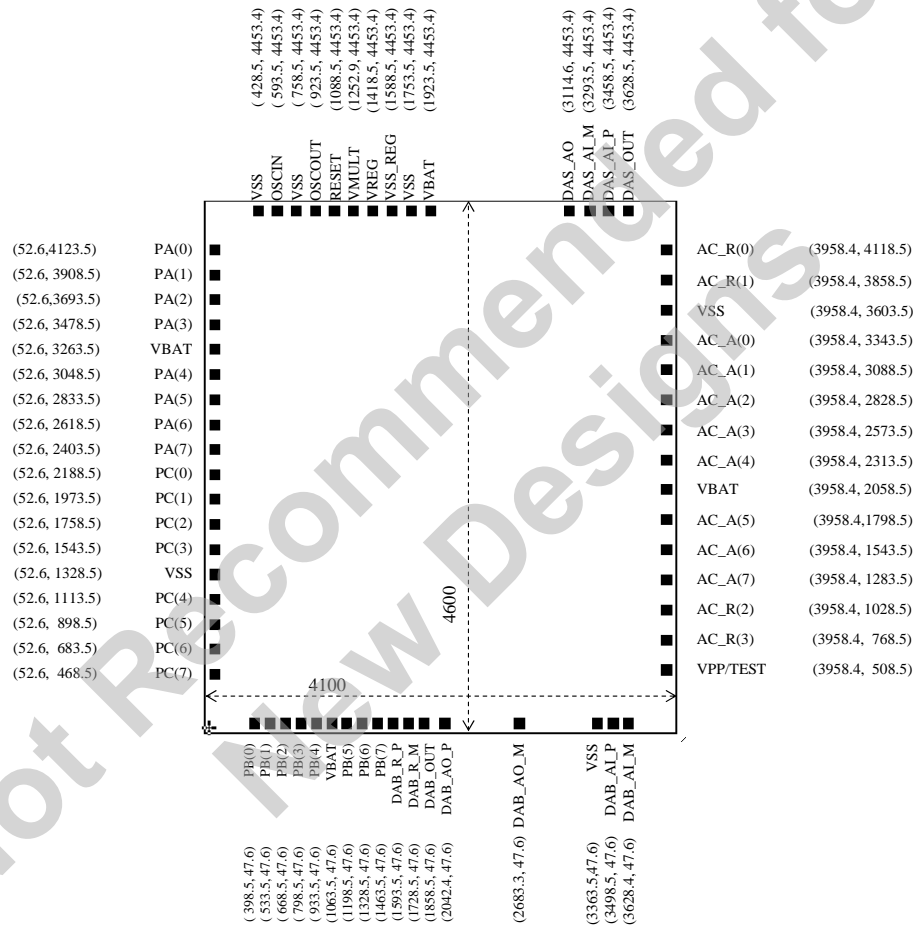

Figure 1-2. Die dimensions and pin coordinates (in μm)

1.2.2 LQFP-64

The XE8805/05A is delivered in a LQFP-64 package. The pin map is given below.

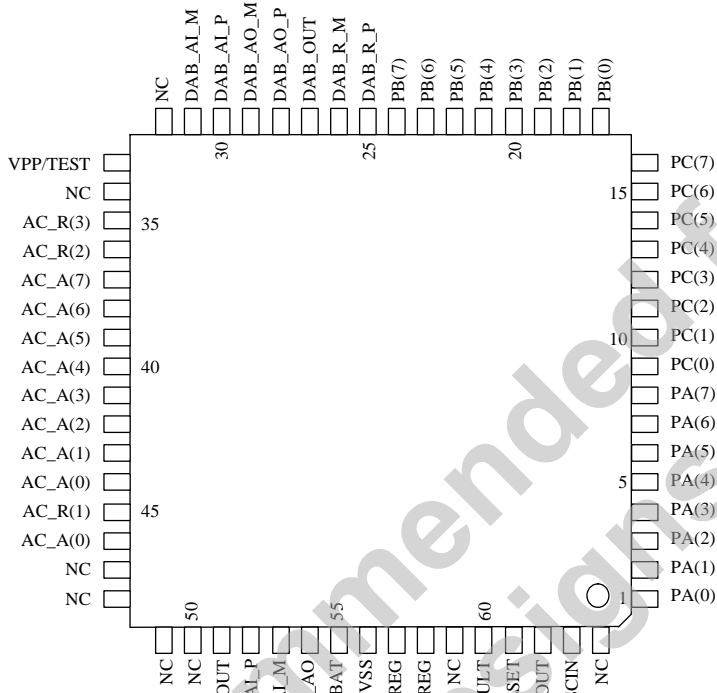

Figure 1-3. LQFP-64 pin map

Package pin	name	Package pin	name
1	PA(0)	33	VPP/TEST
2	PA(1)	34	NC
3	PA(2)	35	AC_R(3)
4	PA(3)	36	AC_R(2)
5	PA(4)	37	AC_A(7)
6	PA(5)	38	AC_A(6)
7	PA(6)	39	AC_A(5)
8	PA(7)	40	AC_A(4)
9	PC(0)	41	AC_A(3)
10	PC(1)	42	AC_A(2)
11	PC(2)	43	AC_A(1)
12	PC(3)	44	AC_A(0)
13	PC(4)	45	AC_R(1)
14	PC(5)	46	AC_R(0)
15	PC(6)	47	NC
16	PC(7)	48	NC
17	PB(0)	49	NC
18	PB(1)	50	NC
19	PB(2)	51	DAS_OUT
20	PB(3)	52	DAS_AI_P

Package pin	name	Package pin	name
21	PB(4)	53	DAS_AI_M
22	PB(5)	54	DAS_AO
23	PB(6)	55	VBAT
24	PB(7)	56	VSS
25	DAB_R_P	57	VSS_REG
26	DAB_R_M	58	VREG
27	DAB_OUT	59	NC
28	DAB_AO_P	60	VMULT
29	DAB_AO_M	61	RESET
30	DAB_AI_P	62	OSCOUT
31	DAB_AI_M	63	OSCIN
32	NC	64	NC

Table 1-1. Bonding plan of the LQFP-64 package (LQFP 64L 10x10mm thick 1.6 mm)

1.3 Pin assignment

The table below gives a short description of the different pin assignments.

Pin	Assignment
VBAT	Positive power supply
VSS VSS_REG	Negative power supply
VREG	Connection for the mandatory external capacitor of the voltage regulator
VPP/TEST	High voltage supply for flash memory programming (NC in ROM versions)
RESET	Resets the circuit when the voltage is high
OSCIN/OSCOUT	Quartz crystal connections, also used for flash memory programming
PA(7:0)	Parallel input port A pins
PB(7:0)	Parallel I/O port B pins
PC(7:0)	Parallel I/O port C pins
AC_A(7:0)	Acquisition chain input pins
AC_R(3:0)	Acquisition chain reference pins
VMULT	Connection for the external capacitor if VBAT is below 3V
DAB_OUT	Bias D/A output
DAB_R_x	Bias D/A reference (x=P: plus, x=M: minus)
DAB_Ax_y	Bias D/A amplifier IO (x=I: input, x=O: output ; y=P: plus, y=M: minus)
DAS_OUT	Signal D/A output
DAS_AI_x	Signal D/A amplifier inputs (x=P: plus, x=M: minus)
DAS_AO	Signal D/A amplifier output

Table 1-2. Pin assignment

Table 1-3 gives a more detailed pin map for the different pins. It also indicates the possible I/O configuration of these pins. The indications in blue bold are the configuration at start-up.

The pins CNTx pins are possible counter inputs, PWMx are possible PWM outputs.

pin	function			I/O configuration						
	first	second	third	AI	AO	DI	DO	OD	PU	POWER
1	PA(0)	CNTA				X			X	
2	PA(1)	CNTB				X			X	
3	PA(2)	CNTC				X			X	
4	PA(3)	CNTD				X			X	
5	PA(4)					X			X	
6	PA(5)					X			X	
7	PA(6)					X			X	
8	PA(7)					X			X	
9	PC(0)					X	X			
10	PC(1)					X	X			
11	PC(2)					X	X			
12	PC(3)					X	X			
13	PC(4)					X	X			
14	PC(5)					X	X			
15	PC(6)					X	X			
16	PC(7)					X	X			
17	PB(0)	PWM0		X	X	X	X	X	X	
18	PB(1)	PWM1		X	X	X	X	X	X	
19	PB(2)			X	X	X	X	X	X	
20	PB(3)			X	X	X	X	X	X	
21	PB(4)	USRT_S0		X	X	X	X	X	X	
22	PB(5)	USRT_S1		X	X	X	X	X	X	
23	PB(6)	UART_Tx		X	X	X	X	X	X	
24	PB(7)	UART_Rx		X	X	X	X	X	X	
25	DAB_R_P			X						
26	DAB_R_M			X						
27	DAB_OUT				X					
28	DAB_AO_P				X					
29	DAB_AO_M				X					
30	DAB_AI_P			X						
31	DAB_AI_M			X						
33	VPP	TEST								X
35	AC_R(3)			X						
36	AC_R(2)			X						
37	AC_A(7)			X						
38	AC_A(6)			X						
39	AC_A(5)			X						
40	AC_A(4)			X						
41	AC_A(3)			X						
42	AC_A(2)			X						
43	AC_A(1)			X						
44	AC_A(0)			X						
45	AC_R(1)			X						
46	AC_R(0)			X						
51	DAS_OUT				X					
52	DAS_AI_P			X						
53	DAS_AI_M			X						
54	DAS_AO				X					
55	VBAT									X

pin	function			I/O configuration						
lqfp-64	first	second	third	AI	AO	DI	DO	OD	PU	POWER
56	VSS									X
57	VSS_REG									X
58	VREG				X					
60	VMULT				X					
61	RESET					X				
62	OSCOUT				X					
63	OSCIN			X						

Pin map table legend:
 blue bold: configuration at start up

- AI: analog input
- AO: analog output
- DI: digital input
- DO: digital output
- OD: nMOS open drain output
- PU: pull-up resistor
- POWER: power supply

Table 1-3. Pin description table

Not Recommended for New Designs

2 XE8805/05A Performance

2.1	Absolute maximum ratings	2-2
2.2	Operating range	2-2
2.3	Supply configurations	2-3
2.3.1	Flash circuit	2-3
2.3.2	ROM circuit	2-3
2.4	Current consumption	2-5
2.5	Operating speed	2-6
2.5.1	Flash version	2-6
2.5.2	ROM circuit version	2-6

Not Recommended for
New Designs

2.1 Absolute maximum ratings

Table 2-1. Absolute maximum ratings

	Min.	Max.		Note
Voltage applied to VBAT with respect to VSS	-0.3	6.0	V	
Voltage applied to VPP with respect to VSS	VBAT-0.3	12	V	
Voltage applied to all pins except VPP and VBAT	VSS-0.3	VBAT+0.3	V	
Storage temperature (ROM device or unprogrammed flash device)	-55	150	°C	
Storage temperature (programmed flash device)	-40	85	°C	

Stresses beyond the absolute maximal ratings may cause permanent damage to the device. Functional operation at the absolute maximal ratings is not implied. Exposure to conditions beyond the absolute maximal ratings may affect the reliability of the device.

2.2 Operating range

Table 2-2. Operating range for the flash device

	Min.	Max.		Note
Voltage applied to VBAT with respect to VSS	2.4	5.5	V	
Voltage applied to VBAT with respect to VSS during the flash programming	3.3	5.5	V	1
Voltage applied to VPP with respect to VSS	VBAT	11.5	V	
Voltage applied to all pins except VPP and VBAT	VSS	VBAT	V	
Operating temperature range	-40	85	°C	
Capacitor on VREG (flash version)	0.8	1.2	μF	2
Capacitor on VMULT	1.0	3.0	nF	3

1. During the programming of the device, the supply voltage should at least be equal to the supply voltage used during normal operation.
2. The capacitor on VREG is mandatory.
3. The capacitor on VMULT is optional. The capacitor has to be present if the multiplier is enabled. The multiplier has to be enabled if VBAT < 3.0V.

Table 2-3. Operating range for the ROM device

	Min.	Max.		Note
Voltage applied to VBAT with respect to VSS	2.4	5.5	V	
Voltage applied to all pins except VPP and VBAT	VSS	VBAT	V	
Operating temperature range	-40	125	°C	
Capacitor on VREG	0.1	1.2	μF	1
Capacitor on VMULT	1.0	3.0	nF	2

1. The capacitor may be omitted when VREG is connected to VBAT.
2. The capacitor on VMULT is optional. The capacitor has to be present if the multiplier is enabled. The multiplier has to be enabled if VBAT < 3.0V.

All specifications in this document are valid for the complete operating range unless otherwise specified.

Table 2-4. Operating range of the Flash memory

	Min.	Max.		Note
Retention time at 85°C	10		years	1
Retention time at 55°C	100		years	1
Number of programming cycles	10			2

1. Valid only if programmed using a programming tool that is qualified
2. Circuits can be programmed more than 10 times but after that, the retention time is no longer guaranteed. All qualification tests have been done after 10 cycles.

2.3 Supply configurations

2.3.1 Flash circuit

The flash version of the circuit can be run from a supply between 2.4V and 5.5V (Figure 2-1). The capacitor on VREG has to be connected at all times (value in Table 2-2) to guarantee proper operation of the device. The capacitor on VMULT is only required if the circuit is to be operated below 3V.

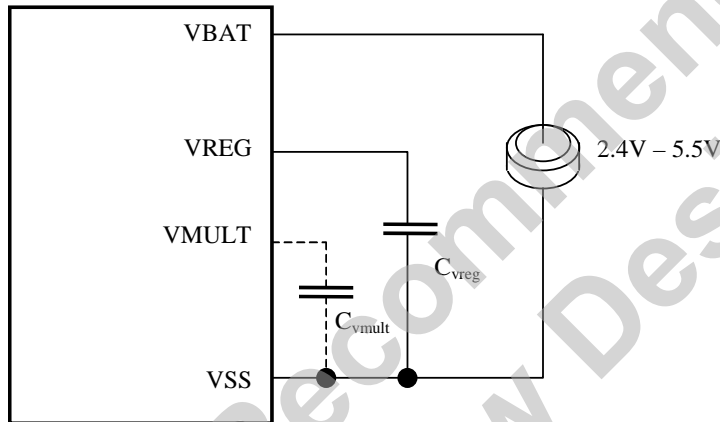

Figure 2-1. Supply configuration for the flash circuit.

2.3.2 ROM circuit

For the ROM version, two possible operating modes exist: with and without voltage regulator. Using the voltage regulator, low power consumption will be obtained even with supply voltages above 2.4V. Without the voltage regulator (i.e. VREG short-circuited to VBAT), a higher speed can be obtained.

2.3.2.1 Low power operation

In this case, the internal voltage regulator is used in order to maintain low power consumption independent from the supply voltage. The capacitor on VREG has to be connected at all times (value in Table 2-3) to guarantee proper operation of the device. The capacitor on VMULT has to be connected only when VBAT < 3V.

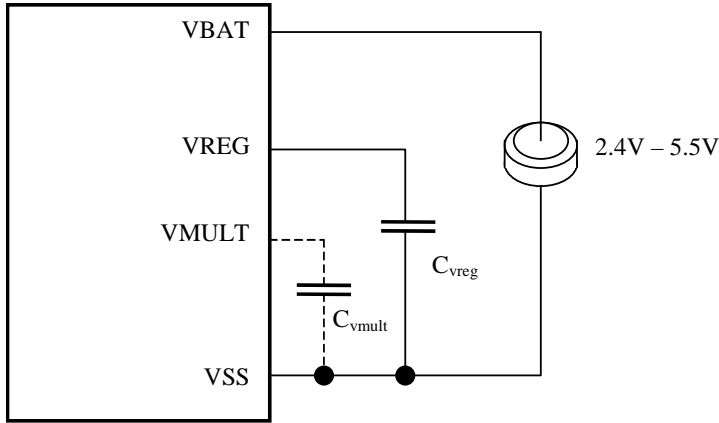

Figure 2-2. Supply voltage connections for low power operation of the ROM version.

2.3.2.2 High speed operation

In this case, the internal voltage regulator is not used. The operation speed of the circuit can be increased with increasing supply voltage but the supply current will also increase. The capacitor on VMULT has to be connected only when $V_{BAT} < 3V$. In this case, the supply voltage can decrease down to 2.15V. Beware however that the zoomingADC™ will not run below 2.4V (see Figure 2-4). In this configuration, the circuit can not be used above 3.3V.

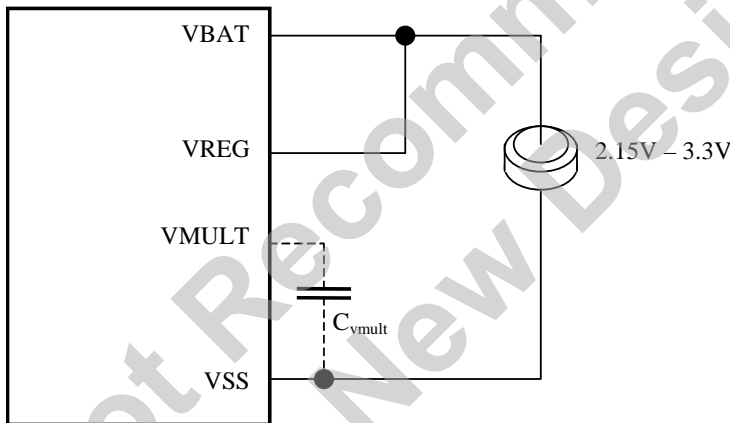

Figure 2-3. Supply voltage connections for high speed operation of the ROM version.

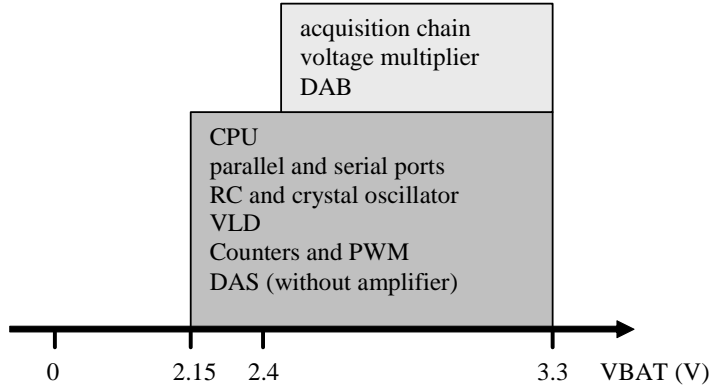

Figure 2-4. Operation range of the different circuit blocks

2.4 Current consumption

The tables below give the current consumption for the circuit in different configurations. The figures are indicative only and may change as a function of the actual software implemented in the circuit.

Table 2-5 gives the current consumption for the flash version of the circuit. The peripherals are disabled. The parallel ports A and B are configured in input with pull up, the parallel port C is configured as an output. Their pins are not connected externally. The pin RESET is connected to VSS and the pin VPP/TEST is connected to VBAT. The inputs of the acquisition chain are connected to VSS.

Table 2-5. Typical current consumption of the XE8805 version (8k instructions flash memory)

Operation mode	CPU	RC	Xtal	Consumption	comments	Note
High speed CPU	1 MIPS	1 MHz	Off	310 μ A	2.4V <> 5.5V, 27°C	
Low power CPU	32 kIPS	Off	32 kHz	10 μ A	2.4V <> 5.5V, 27°C	
Low power time keeping	HALT	Off	32 kHz	1.0 μ A	2.4V <> 5.5V, 27°C	
Fast wake-up time keeping	HALT	Ready	32kHz	1.7 μ A	2.4V <> 5.5V, 27°C	
Immediate wake-up time keeping	HALT	100 kHz	Off	1.4 μ A	2.4V <> 5.5V, 27°C	
VLD static current				15 μ A	2.4V <> 5.5V, 27°C	
16 bit resolution data acquisition	HALT	2 MHz	Off	190 μ A	3.0V, 27°C	1
12 bit , gain 100, data acquisition	HALT	2 MHz	Off	460 μ A	3.0V, 27°C	2

1. PGA disabled, ADC enabled, 16 bit resolution
2. PGA 1 disabled, PGA 2 and 3 enabled, ADC enabled, 12 bit resolution

For more information concerning the current consumption of the zoomingADC™, see the chapter power consumption in the acquisition chain documentation which shows the current consumption of this block as a function of temperature and voltage and for different configurations of the PGA and ADC.

The power consumption of the ROM version of the circuit is identical if it is configured as shown in Figure 2-2. In the high speed configuration, the current consumption will increase proportional with VBAT.

2.5 Operating speed

2.5.1 Flash version

The speed of the devices is not highly dependent upon the supply voltage. However, by limiting the temperature range, the speed can be increased. The minimal guaranteed speed as a function of the supply voltage and maximal temperature operating temperature is given in Figure 2-5.

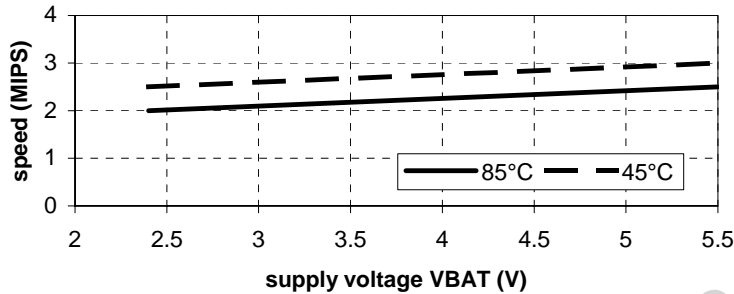

Figure 2-5. Guaranteed speed as a function of the supply voltage and maximal temperature.

2.5.2 ROM circuit version

2.5.2.1 Low power supply configuration

In the low power supply configuration as shown in Figure 2-2, the operating speed does not depend highly on the supply voltage as shown in Figure 2-6.

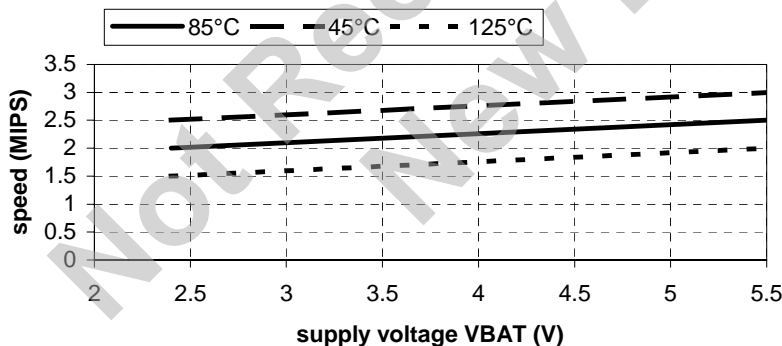

Figure 2-6. Guaranteed speed as a function of supply voltage and for different maximal temperatures using the voltage regulator.

2.5.2.2 High speed supply configuration

In the high speed supply configuration of Figure 2-3, the guaranteed speed of the circuit is shown in Figure 2-7.

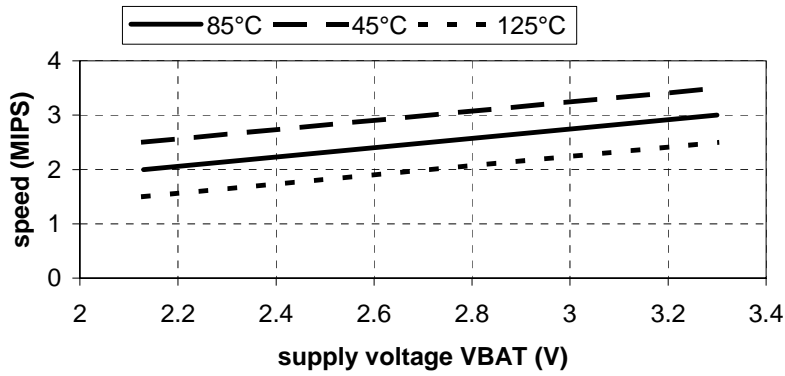

Figure 2-7. Guaranteed speed as a function of supply voltage and for three temperature ranges when VREG=VBAT.

Not Recommended for New Designs

3. CPU

CONTENTS

3.1	CPU description	3-2
3.2	CPU internal registers	3-2
3.3	CPU instruction short reference	3-4

Not Recommended for
New Designs

3.1 CPU description

The CPU of the XE8000 series is a low power RISC core. It has 16 internal registers for efficient implementation of the C compiler. Its instruction set is made up of 35 generic instructions, all coded on 22 bits, with 8 addressing modes. All instructions are executed in one clock cycle, including conditional jumps and 8x8 multiplication. The circuit therefore runs on 1 MIPS on a 1MHz clock.

The CPU hardware and software description is given in the document “Coolrisc816 Hardware and Software Reference Manual”. A short summary is given in the following paragraphs.

The good code efficiency of the CPU core makes it possible to compute a polynomial like $Z = (A_0 + A_1 \cdot Y) \cdot X + B_0 + B_1 \cdot Y$ in less than 300 clock cycles (software code generated by the XEMICS C-compiler, all numbers are signed integers on 16 bits).

3.2 CPU internal registers

As shown in Figure 3-1, the CPU has 16 internal 8-bit registers. Some of these registers can be concatenated to a 16-bit word for use in some instructions. The function of these registers is defined in Table 3-1. The status register stat (Table 3-2) is used to manage the different interrupt and event levels. An interrupt or an event can both be used to wake up after a HALT instruction. The difference is that an interrupt jumps to a special interrupt function whereas an event continues the software execution with the instruction following the HALT instruction.

The program counter (PC) is a 16 bit register that indicates the address of the instruction that has to be executed. The stack (ST_n) is used to memorise the return address when executing subroutines or interrupt routines.

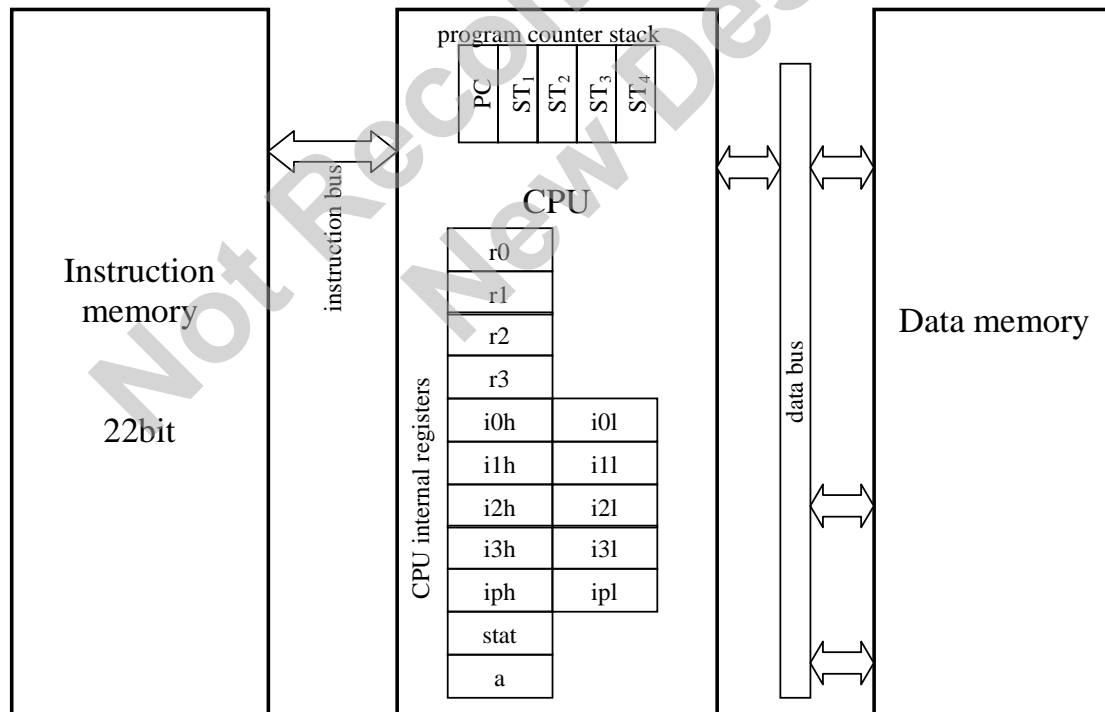

Figure 3-1. CPU internal registers

Register name	Register function
r0	general purpose
r1	general purpose
r2	general purpose
r3	data memory offset
i0h	MSB of the data memory index i0
i0l	LBS of the data memory index i0
i1h	MSB of the data memory index i1
i1l	LBS of the data memory index i1
i2h	MSB of the data memory index i2
i2l	LBS of the data memory index i2
i3h	MSB of the data memory index i3
i3l	LBS of the data memory index i3
iph	MSB of the program memory index ip
ipl	LBS of the program memory index ip
stat	status register
a	accumulator

Table 3-1. CPU internal register definition

bit	name	function
7	IE2	enables (when 1) the interrupt request of level 2
6	IE1	enables (when 1) the interrupt request of level 1
5	GIE	enables (when 1) all interrupt request levels
4	IN2	interrupt request of level 2. The interrupts labelled "low" in the interrupt handler are routed to this interrupt level. This bit has to be cleared when the interrupt is served.
3	IN1	interrupt request of level 1. The interrupts labelled "mid" in the interrupt handler are routed to this interrupt level. This bit has to be cleared when the interrupt is served.
2	IN0	interrupt request of level 0. The interrupts labelled "hig" in the interrupt handler are routed to this interrupt level. This bit has to be cleared when the interrupt is served.
1	EV1	event request of level 1. The events labelled "low" in the event handler are routed to this event level. This bit has to be cleared when the event is served.
0	EVO	event request of level 0. The events labelled "hig" in the event handler are routed to this event level. This bit has to be cleared when the event is served.

Table 3-2. Status register description

The CPU also has a number of flags that can be used for conditional jumps. These flags are defined in Table 3-3.

symbol	name	function
Z	zero	Z=1 when the accumulator a content is zero
C	carry	This flag is used in shift or arithmetic operations. For a shift operation, it has the value of the bit that was shifted out (LSB for shift right, MSB for shift left). For an arithmetic operation with unsigned numbers: it is 1 at occurrence of an overflow during an addition (or equivalent). it is 0 at occurrence of an underflow during a subtraction (or equivalent).
V	overflow	This flag is used in shift or arithmetic operations. For arithmetic or shift operations with signed numbers, it is 1 if an overflow or underflow occurs.

Table 3-3. Flag description

3.3 CPU instruction short reference

Table 3-4 shows a short description of the different instructions available on the Coolisc816. The notation **cc** in the conditional jump instruction refers to the condition description as given in Table 3-6. The notation **reg**, **reg1**, **reg2**, **reg3** refers to one of the CPU internal registers of Table 3-1. The notation **eaddr** and **DM(eaddr)** refer to one of the extended address modes as defined in Table 3-5. The notation **DM(xxx)** refers to the data memory location with address xxx.

Instruction	Modification	Operation
Jump addr[15:0]	-,-,-,-	PC := addr[15:0]
Jump ip	-,-,-,-	PC := ip
Jcc addr[15:0]	-,-,-,-	if cc is true then PC := addr[15:0]
Jcc ip	-,-,-,-	if cc is true then PC := ip
Call addr[15:0]	-,-,-,-	ST _{n+1} := ST _n (n>1); ST ₁ := PC+1; PC := addr[15:0]
Call ip	-,-,-,-	ST _{n+1} := ST _n (n>1); ST ₁ := PC+1; PC := ip
Calls addr[15:0]	-,-,-,-	ip := PC+1; PC := addr[15:0]
Calls ip	-,-,-,-	ip := PC+1; PC := ip
Ret	-,-,-,-	PC := ST ₁ ; ST _n := ST _{n+1} (n>1)
Rets	-,-,-,-	PC := ip
Reti	-,-,-,-	PC := ST ₁ ; ST _n := ST _{n+1} (n>1); GIE := 1
Push	-,-,-,-	PC := PC+1; ST _{n+1} := ST _n (n>1); ST ₁ := ip
Pop	-,-,-,-	PC := PC+1; ip := ST ₁ ; ST _n := ST _{n+1} (n>1)
Move reg,#data[7:0]	-,-, Z, a	a := data[7:0]; reg := data[7:0]
Move reg1, reg2	-,-, Z, a	a := reg2 ; reg1 := reg2
Move reg, eaddr	-,-, Z, a	a := DM(eaddr) ; reg := DM(eaddr)
Move eaddr, reg	-,-,-,-	DM(eaddr) := reg
Move addr[7:0],#data[7:0]	-,-,-,-	DM(addr[7:0]) := data[7:0]
Cmvd reg1, reg2	-,-, Z, a	a := reg2 ; if C=0 then reg1 := a;
Cmvd reg, eaddr	-,-, Z, a	a := DM(eaddr) ; if C=0 then reg := a
Cmvs reg1, reg2	-,-, Z, a	a := reg2 ; if C=1 then reg1 := a;
Cmvs reg, eaddr	-,-, Z, a	a := DM(eaddr) ; if C=1 then reg := a
Shl reg1, reg2	C, V, Z, a	a := reg2 <<1; a[0] := 0; C := reg2 [7]; reg1 := a
Shl reg	C, V, Z, a	a := reg <<1; a[0] := 0; C := reg [7]; reg := a
Shl reg, eaddr	C, V, Z, a	a := DM(eaddr) <<1; a[0] := 0; C := DM(eaddr) [7]; reg := a
Shlc reg1, reg2	C, V, Z, a	a := reg2 <<1; a[0] := C; C := reg2 [7]; reg1 := a
Shlc reg	C, V, Z, a	a := reg <<1; a[0] := C; C := reg [7]; reg := a
Shlc reg, eaddr	C, V, Z, a	a := DM(eaddr) <<1; a[0] := C; C := DM(eaddr) [7]; reg := a
Shr reg1, reg2	C, V, Z, a	a := reg2 >>1; a[7] := 0; C := reg2 [0]; reg1 := a
Shr reg	C, V, Z, a	a := reg >>1; a[7] := 0; C := reg [0]; reg := a
Shr reg, eaddr	C, V, Z, a	a := DM(eaddr) >>1; a[7] := 0; C := DM(eaddr) [0]; reg := a
Shrc reg1, reg2	C, V, Z, a	a := reg2 >>1; a[7] := C; C := reg2 [0]; reg1 := a
Shrc reg	C, V, Z, a	a := reg >>1; a[7] := C; C := reg [0]; reg := a
Shrc reg, eaddr	C, V, Z, a	a := DM(eaddr) >>1; a[7] := C; C := DM(eaddr) [0]; reg := a
Shra reg1, reg2	C, V, Z, a	a := reg2 >>1; a[7] := reg2 [7]; C := reg2 [0]; reg1 := a
Shra reg	C, V, Z, a	a := reg >>1; a[7] := reg [7]; C := reg [0]; reg := a
Shra reg, eaddr	C, V, Z, a	a := DM(eaddr) >>1; a[7] := DM(eaddr) [7]; C := DM(eaddr) [0]; reg := a
Cpl1 reg1, reg2	-,-, Z, a	a := NOT(reg2); reg1 := a
Cpl1 reg	-,-, Z, a	a := NOT(reg); reg := a
Cpl1 reg, eaddr	-,-, Z, a	a := NOT(DM(eaddr)); reg := a
Cpl2 reg1, reg2	C, V, Z, a	a := NOT(reg2)+1; if a=0 then C:=1 else C := 0; reg1 := a
Cpl2 reg	C, V, Z, a	a := NOT(reg)+1; if a=0 then C:=1 else C := 0; reg := a
Cpl2 reg, eaddr	C, V, Z, a	a := NOT(DM(eaddr))+1; if a=0 then C:=1 else C := 0; reg := a
Cpl2c reg1, reg2	C, V, Z, a	a := NOT(reg2)+C; if a=0 and C=1 then C:=1 else C := 0; reg1 := a
Cpl2c reg	C, V, Z, a	a := NOT(reg)+C; if a=0 and C=1 then C:=1 else C := 0; reg := a
Cpl2c reg, eaddr	C, V, Z, a	a := NOT(DM(eaddr))+C; if a=0 and C=1 then C:=1 else C := 0; reg := a
Inc reg1, reg2	C, V, Z, a	a := reg2 +1; if a=0 then C := 1 else C := 0; reg1 := a
Inc reg	C, V, Z, a	a := reg +1; if a=0 then C := 1 else C := 0; reg := a
Inc reg, eaddr	C, V, Z, a	a := DM(eaddr) +1; if a=0 then C := 1 else C := 0; reg := a
Incc reg1, reg2	C, V, Z, a	a := reg2 +C; if a=0 and C=1 then C := 1 else C := 0; reg1 := a
Incc reg	C, V, Z, a	a := reg +C; if a=0 and C=1 then C := 1 else C := 0; reg := a
Incc reg, eaddr	C, V, Z, a	a := DM(eaddr) +C; if a=0 and C=1 then C := 1 else C := 0; reg := a
Dec reg1, reg2	C, V, Z, a	a := reg2 -1; if a=hFF then C := 0 else C := 1; reg1 := a

Dec reg	C, V, Z, a	a := reg-1; if a=hFF then C := 0 else C := 1; reg := a
Dec reg, eaddr	C, V, Z, a	a := DM(eaddr)-1; if a=hFF then C := 0 else C := 1; reg := a
Decc reg1, reg2	C, V, Z, a	a := reg2-(1-C); if a=hFF and C=0 then C := 0 else C := 1; reg1 := a
Decc reg	C, V, Z, a	a := reg-(1-C); if a=hFF and C=0 then C := 0 else C := 1; reg := a
Decc reg, eaddr	C, V, Z, a	a := DM(eaddr)-(1-C); if a=hFF and C=0 then C := 0 else C := 1; reg := a
And reg,#data[7:0]	-, -, Z, a	a := reg and data[7:0]; reg := a
And reg1, reg2, reg3	-, -, Z, a	a := reg2 and reg3; reg1 := a
And reg1, reg2	-, -, Z, a	a := reg1 and reg2; reg1 := a
And reg, eaddr	-, -, Z, a	a := reg and DM(eaddr); reg := a
Or reg,#data[7:0]	-, -, Z, a	a := reg or data[7:0]; reg := a
Or reg1, reg2, reg3	-, -, Z, a	a := reg2 or reg3; reg1 := a
Or reg1, reg2	-, -, Z, a	a := reg1 or reg2; reg1 := a
Or reg, eaddr	-, -, Z, a	a := reg or DM(eaddr); reg := a
Xor reg,#data[7:0]	-, -, Z, a	a := reg xor data[7:0]; reg := a
Xor reg1, reg2, reg3	-, -, Z, a	a := reg2 xor reg3; reg1 := a
Xor reg1, reg2	-, -, Z, a	a := reg1 xor reg2; reg1 := a
Xor reg, eaddr	-, -, Z, a	a := reg xor DM(eaddr); reg := a
Add reg,#data[7:0]	C, V, Z, a	a := reg+data[7:0]; if overflow then C:=1 else C := 0; reg := a
Add reg1, reg2, reg3	C, V, Z, a	a := reg2+reg3; if overflow then C:=1 else C := 0; reg1 := a
Add reg1, reg2	C, V, Z, a	a := reg1+reg2; if overflow then C:=1 else C := 0; reg1 := a
Add reg, eaddr	C, V, Z, a	a := reg+DM(eaddr); if overflow then C:=1 else C := 0; reg := a
Addc reg,#data[7:0]	C, V, Z, a	a := reg+data[7:0]+C; if overflow then C:=1 else C := 0; reg := a
Addc reg1, reg2, reg3	C, V, Z, a	a := reg2+reg3+C; if overflow then C:=1 else C := 0; reg1 := a
Addc reg1, reg2	C, V, Z, a	a := reg1+reg2+C; if overflow then C:=1 else C := 0; reg1 := a
Addc reg, eaddr	C, V, Z, a	a := reg+DM(eaddr)+C; if overflow then C:=1 else C := 0; reg := a
Subd reg,#data[7:0]	C, V, Z, a	a := data[7:0]-reg; if underflow then C := 0 else C := 1; reg := a
Subd reg1, reg2, reg3	C, V, Z, a	a := reg2-reg3; if underflow then C := 0 else C := 1; reg1 := a
Subd reg1, reg2	C, V, Z, a	a := reg2-reg1; if underflow then C := 0 else C := 1; reg1 := a
Subd reg, eaddr	C, V, Z, a	a := DM(eaddr)-reg; if underflow then C := 0 else C := 1; reg := a
Subdc reg,#data[7:0]	C, V, Z, a	a := data[7:0]-reg-(1-C); if underflow then C := 0 else C := 1; reg := a
Subdc reg1, reg2, reg3	C, V, Z, a	a := reg2-reg3-(1-C); if underflow then C := 0 else C := 1; reg1 := a
Subdc reg1, reg2	C, V, Z, a	a := reg2-reg1-(1-C); if underflow then C := 0 else C := 1; reg1 := a
Subdc reg, eaddr	C, V, Z, a	a := DM(eaddr)-reg-(1-C); if underflow then C := 0 else C := 1; reg := a
Subs reg,#data[7:0]	C, V, Z, a	a := reg-data[7:0]; if underflow then C := 0 else C := 1; reg := a
Subs reg1, reg2, reg3	C, V, Z, a	a := reg3-reg2; if underflow then C := 0 else C := 1; reg1 := a
Subs reg1, reg2	C, V, Z, a	a := reg1-reg2; if underflow then C := 0 else C := 1; reg1 := a
Subs reg, eaddr	C, V, Z, a	a := reg-DM(eaddr); if underflow then C := 0 else C := 1; reg := a
Subsc reg,#data[7:0]	C, V, Z, a	a := reg-data[7:0]-(1-C); if underflow then C := 0 else C := 1; reg := a
Subsc reg1, reg2, reg3	C, V, Z, a	a := reg3-reg2-(1-C); if underflow then C := 0 else C := 1; reg1 := a
Subsc reg1, reg2	C, V, Z, a	a := reg1-reg2-(1-C); if underflow then C := 0 else C := 1; reg1 := a
Subsc reg, eaddr	C, V, Z, a	a := reg-DM(eaddr)-(1-C); if underflow then C := 0 else C := 1; reg := a
Mul reg,#data[7:0]	u, u, u, a	a := (data[7:0]*reg)[7:0]; reg := (data[7:0]*reg)[15:8]
Mul reg1, reg2, reg3	u, u, u, a	a := (reg2*reg3)[7:0]; reg1 := (reg2*reg3)[15:8]
Mul reg1, reg2	u, u, u, a	a := (reg2*reg1)[7:0]; reg1 := (reg2*reg1)[15:8]
Mul reg, eaddr	u, u, u, a	a := (DM(eaddr)*reg)[7:0]; reg := (DM(eaddr)*reg)[15:8]
Mula reg,#data[7:0]	u, u, u, a	a := (data[7:0]*reg)[7:0]; reg := (data[7:0]*reg)[15:8]
Mula reg1, reg2, reg3	u, u, u, a	a := (reg2*reg3)[7:0]; reg1 := (reg2*reg3)[15:8]
Mula reg1, reg2	u, u, u, a	a := (reg2*reg1)[7:0]; reg1 := (reg2*reg1)[15:8]
Mula reg, eaddr	u, u, u, a	a := (DM(eaddr)*reg)[7:0]; reg := (DM(eaddr)*reg)[15:8]
Mshl reg,#shift[2:0]	u, u, u, a	a := (reg*2 ^{shift})[7:0]; reg := (reg*2 ^{shift})[15:8]
Mshr reg,#shift[2:0]	u, u, u, a	a := (reg*2 ^(8-shift))[7:0]; reg := (reg*2 ^(8-shift))[15:8]
Mshra reg,#shift[2:0]	u, u, u, a*	a := (reg*2 ^(8-shift))[7:0]; reg := (reg*2 ^(8-shift))[15:8]
Cmp reg,#data[7:0]	C, V, Z, a	a := data[7:0]-reg; if underflow then C :=0 else C:=1; V := C and (not Z)
Cmp reg1, reg2	C, V, Z, a	a := reg2-reg1; if underflow then C :=0 else C:=1; V := C and (not Z)
Cmp reg, eaddr	C, V, Z, a	a := DM(eaddr)-reg; if underflow then C :=0 else C:=1; V := C and (not Z)
Cmpa reg,#data[7:0]	C, V, Z, a	a := data[7:0]-reg; if underflow then C :=0 else C:=1; V := C and (not Z)
Cmpa reg1, reg2	C, V, Z, a	a := reg2-reg1; if underflow then C :=0 else C:=1; V := C and (not Z)
Cmpa reg, eaddr	C, V, Z, a	a := DM(eaddr)-reg; if underflow then C :=0 else C:=1; V := C and (not Z)
Tstb reg,#bit[2:0]	-, -, Z, a	a[bit] := reg[bit]; other bits in a are 0
Setb reg,#bit[2:0]	-, -, Z, a	reg[bit] := 1; other bits unchanged; a := reg
Clrb reg,#bit[2:0]	-, -, Z, a	reg[bit] := 0; other bits unchanged; a := reg
Invb reg,#bit[2:0]	-, -, Z, a	reg[bit] := not reg[bit]; other bits unchanged; a := reg

Sflag	-, -, a	a[7] := C; a[6] := C xor V; a[5] := ST full; a[4] := ST empty
Rflag <i>reg</i>	C, V, Z, a	a := <i>reg</i> << 1; ; a[0] := 0; C := <i>reg</i> [7]
Rflag <i>eaddr</i>	C, V, Z, a	a := DM (<i>eaddr</i>) << 1; a[0] := 0; C := DM (<i>eaddr</i>)[7]
Freq <i>divn</i>	-, -, -	reduces the CPU frequency (divn=nodiv, div2, div4, div8, div16)
Halt	-, -, -	halts the CPU
Nop	-, -, -	no operation

- = unchanged, u = undefined, *MSHR *reg*, # 1 doesn't shift by 1

Table 3-4. Instruction short reference

The Coolisc816 has 8 different addressing modes. These modes are described in Table 3-5. In this table, the notation *ix* refers to one of the data memory index registers *i0*, *i1*, *i2* or *i3*. Using **eaddr** in an instruction of Table 3-4 will access the data memory at the address **DM**(**eaddr**) and will simultaneously execute the index operation.

extended address eaddr	accessed data memory location DM (eaddr)	index operation	
addr [7:0]	DM (h00& addr [7:0])	-	direct addressing
(<i>ix</i>)	DM (<i>ix</i>)	-	indexed addressing
(<i>ix</i> , offset [7:0])	DM (<i>ix</i> + offset)	-	indexed addressing with immediate offset
(<i>ix</i> , <i>r3</i>)	DM (<i>ix</i> + <i>r3</i>)	-	indexed addressing with register offset
(<i>ix</i>)+	DM (<i>ix</i>)	<i>ix</i> := <i>ix</i> +1	indexed addressing with index post-increment
(<i>ix</i> , offset [7:0])+	DM (<i>ix</i> + offset)	<i>ix</i> := <i>ix</i> + offset	indexed addressing with index post-increment by the offset
-(<i>ix</i>)	DM (<i>ix</i> -1)	<i>ix</i> := <i>ix</i> -1	indexed addressing with index pre-decrement
-(<i>ix</i> , offset [7:0])	DM (<i>ix</i> - offset)	<i>ix</i> := <i>ix</i> - offset	indexed addressing with index pre-decrement by the offset

Table 3-5. Extended address mode description

Eleven different jump conditions are implemented as shown in Table 3-6. The contents of the column **CC** in this table should replace the **CC** notation in the instruction description of Table 3-4.

CC	condition
CS	C=1
CC	C=0
ZS	Z=1
ZC	Z=0
VS	V=1
VC	V=0
EV	(EV1 or EV0)=1
<i>After CMP op1, op2</i>	
EQ	op1=op2
NE	op1≠op2
GT	op1>op2
GE	op1≥op2
LT	op1<op2
LE	op1≤op2

Table 3-6. Jump condition description

4 Memory Mapping

4.1	Memory organisation	4-2
4.2	Quick reference data memory register map	4-2
4.2.1	Low power data registers (h0000-h0007)	4-3
4.2.2	System, clock configuration and reset configuration (h0010-h001F)	4-4
4.2.3	Port A (h0020-h0027)	4-4
4.2.4	Port B (h0028-h002F)	4-4
4.2.5	Port C (h0030-h0033)	4-5
4.2.6	Flash programming (h0038-003B)	4-5
4.2.7	Event handler (h003C-h003F)	4-5
4.2.8	Interrupt handler (h0040-h0047)	4-6
4.2.9	USRT (h0048-h004F)	4-7
4.2.10	UART (h0050-h0057)	4-7
4.2.11	Counter/Timer/PWM registers (h0058-h005F)	4-7
4.2.12	Acquisition chain registers (h0060-h0067)	4-8
4.2.13	Signal D/A registers (h0074-h0077)	4-8
4.2.14	Bias D/A registers (h0078-h0079)	4-8
4.2.15	Voltage multiplier (h007C)	4-8
4.2.16	Voltage Level Detector registers (h007E-h007F)	4-9
4.2.17	RAM (h0080-h027F)	4-9

4.1 Memory organisation

The XE8805 CPU is built with a Harvard architecture. The Harvard architecture uses separate instruction and data memories. The instruction bus and data bus are also separated. The advantage of such a structure is that the CPU can get a new instruction and read/write data simultaneously. The circuit configuration is shown in Figure 4-1. The CPU has its 16 internal registers. The instruction memory has a capacity of 8192 22-bit instructions. The data memory space has 8 low power registers, the peripheral register space and 512 bytes of RAM.

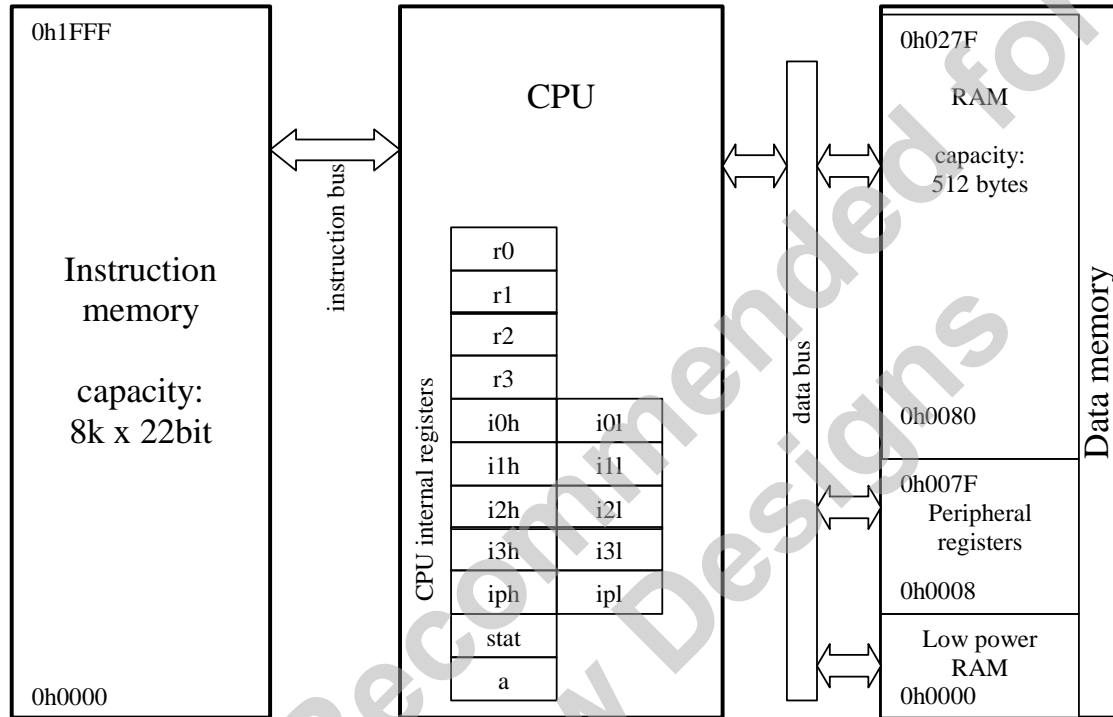

Figure 4-1. Memory mapping

The CPU internal registers are described in the CPU chapter. A short reference of the low power registers and peripheral registers is given in 4.2.

4.2 Quick reference data memory register map

The data register map is given in the tables below. A more detailed description of the different registers is given in the detailed description of the different peripherals.

The tables give the following information:

1. The register name and register address
2. The different bits in the register
3. The access mode of the different bits (see Table 4-1 for code description)
4. The reset source and reset value of the different bits

The reset source coding is given in Table 4-2. To get a full description of the reset sources, please refer to the reset block chapter.

code	access mode
r	bit can be read
w	bit can be written
r0	bit always reads 0
r1	bit always reads 1
c	bit is cleared by writing any value
c1	bit is cleared by writing a 1
ca	bit is cleared after reading
s	special function, verify the detailed description in the respective peripherals

Table 4-1. Access mode codes used in the register definitions

code	reset source
sys	resetsystem
cold	resetcold
pconf	resetpconf
sleep	resetsleep

Table 4-2. Reset source coding used in the register definitions

4.2.1 Low power data registers (h0000-h0007)

Address	Name	7	6	5	4	3	2	1	0
h0000	Reg00	Reg00[7:0] rw, xxxxxxxx,-							
h0001	Reg01	Reg01[7:0] rw, xxxxxxxx,-							
h0002	Reg02	Reg02[7:0] rw, xxxxxxxx,-							
h0003	Reg03	Reg03[7:0] rw, xxxxxxxx,-							
h0004	Reg04	Reg04[7:0] rw, xxxxxxxx,-							
h0005	Reg05	Reg05[7:0] rw, xxxxxxxx,-							
h0006	Reg06	Reg06[7:0] rw, xxxxxxxx,-							
h0007	Reg07	Reg07[7:0] rw, xxxxxxxx,-							

Table 4-3. Low power data registers

4.2.2 System, clock configuration and reset configuration (h0010-h001F)

Name	7	6	5	4	3	2	1	0
RegSysCtrl h0010	SleepEn rw,0,cold	EnResPConf rw,0,cold	EnBusError rw,0,cold	EnResWD rw,0,cold	r0	r0	r0	r0
RegSysReset h0011	Sleep rw,0,sys		ResetBusError rc, 0, cold	ResetWD rc, 0, cold	ResetfromportA rc, 0, cold	ResPad rc,0,cold	ResPadSleep rc,0,cold	r0
RegSysClock h0012	CpuSel rw,0,sleep	ExtClk r,0,cold	EnExtClock rw,0,cold	BiasRC rw,1,cold	ColdXtal r,1,sleep	ColdRC r,1,sleep	EnableXtal rw,0,sleep	EnableRC rw,1,sleep
RegSysMisc h0013	r0	r0	r0	r0	RConPA0 rw,0,sleep	DebFast rw,0,sleep	OutputCkXtal rw,0,sleep	OutputCpuCk rw,0,sleep
RegSysWd h0014	r0	r0	r0	r0	WatchDog[3:0] s,0000,cold			
RegSysPre0 h0015	r0	r0	r0	r0	r0	r0	r0	ResPre c1r0,0,-
RegSysRcTrim1 h001B	r0	r0	Reserved rw,0,cold	RcFreqRange rw,0,cold	RcFreqCoarse[3:0] rw,0000,cold			
RegSysRcTrim2 h001C	r0	r0	RcFreqFine[5:0] rw,10000,cold					

Table 4-4. Reset block and clock block registers

4.2.3 Port A (h0020-h0027)

Name	7	6	5	4	3	2	1	0
RegPAln h0020	PAln[7:0] r							
RegPADebounce h0021	PADebounce[7:0] rw,00000000,pconf							
RegPAEdge h0022	PAEdge[7:0] rw,00000000,sys							
RegPAPullup h0023	PAPullup[7:0] rw,00000000,pconf							
RegPARes0 h0024	PARes0[7:0] rw,00000000,sys							
RegPARes1 h0025	PARes1[7:0] rw,00000000,sys							

Table 4-5. Port A registers

4.2.4 Port B (h0028-h002F)

Name	7	6	5	4	3	2	1	0
RegPBOut h0028	PBOut[7:0] rw,00000000,pconf							
RegPBIn h0029	PBIn[7:0] r							
RegPBDir h002A	PBDir[7:0] rw,00000000,pconf							
RegPBOpen h002B	PBOpen[7:0] rw,00000000,pconf							
RegPBPullup h002C	PBPullup[7:0] rw,00000000,pconf							
RegPBAna h002D	r0	r0	r0	r0	PBAna[3:0] rw,0000,pconf			

Table 4-6. Port B registers

4.2.5 Port C (h0030-h0033)

Address	Name	7	6	5	4	3	2	1	0
h0030	RegPCOut	PCOut[7:0] rw,00000000,pconf							
h0031	RegPCIn	PCIn[7:0] r,-,-							
h0032	RegPCDir	PD1Dir[7:0] rw,00000000,pconf							

Table 4-7. Port C registers

4.2.6 Flash programming (h0038-003B)

These four registers are used during flash programming only. Refer to the flash programming algorithm documentation for more details.

4.2.7 Event handler (h003C-h003F)

Address	Name	7	6	5	4	3	2	1	0
h003C	RegEvn	CntlqA rc1,0,sys	CntlqC rc1,0,sys	128Hz rc1,0,sys	PAEvn[1] rc1,0,sys	CntlqB rc1,0,sys	CntlqD rc1,0,sys	1Hz rc1,0,sys	PAEvn[0] rc1,0,sys
h003D	RegEvnEn	EvnEn[7:0] rw,00000000,sys							
h003E	RegEvnPriority	EvnPriority[7:0] r,11111111,sys							
h003F	RegEvnEvn	r0	r0	r0	r0	r0	r0	EvnHigh r,0,sys	EvnLow r,0,sys

Table 4-8. Event handler registers

The origin of the different events is summarised in the table below.

Event	Event source
CntlqA	Counter/Timer A (counter block)
CntlqB	Counter/Timer B (counter block)
CntlqC	Counter/Timer C (counter block)
CntlqD	Counter/Timer D (counter block)
128Hz	Low prescaler (clock block)
1Hz	Low prescaler (clock block)
PAEvn[1:0]	Port A

Table 4-9. Event source description

4.2.8 Interrupt handler (h0040-h0047)

Address	Name	7	6	5	4	3	2	1	0
h0040	RegIrqHig	IrqAC rc1,0,sys	128Hz rc1,0,sys	r0	CntlrqA rc1,0,sys	CntlrqC rc1,0,sys	r0	UartlrqTx rc1,0,sys	UartlrqRx rc1,0,sys
h0041	RegIrqMid	UsrtCond1 rc1,0,sys	UsrtCond2 rc1,0,sys	PAIrq[5] rc1,0,sys	PAIrq[4] rc1,0,sys	1Hz rc1,0,sys	Vldlrq rc1,0,sys	PAIrq[1] rc1,0,sys	PAIrq[0] rc1,0,sys
h0042	RegIrqLow	PAIrq[7] rc1,0,sys	PAIrq[6] rc1,0,sys	CntlrqB rc1,0,sys	CntlrqD rc1,0,sys	PAIrq[3] rc1,0,sys	PAIrq[2] rc1,0,sys	r0	r0
h0043	RegIrqEnHig	IrqEnHig[7:0] rw,0000000,sys							
h0044	RegIrqEnMid	IrqEnMid[7:0] rw,0000000,sys							
h0045	RegIrqEnLow	IrqEnLow[7:0] rw,0000000,sys							
h0046	RegIrqPriority	IrqPriority[7:0] r,11111111,sys							
h0047	RegIrqIrq	r0	r0	r0	r0	r0	IrqHig r,0,sys	IrqMid r,0,sys	IrqLow r,0,sys

Table 4-10. Interrupt handler registers

The origin of the different interrupts is summarised in the table below.

Event	Event source
CntlrqA	Counter/Timer A (counter block)
CntlrqB	Counter/Timer B (counter block)
CntlrqC	Counter/Timer C (counter block)
CntlrqD	Counter/Timer D (counter block)
128Hz	Low prescaler (clock block)
1Hz	Low prescaler (clock block)
PAIrq[7:0]	Port A
UartlrqRx	UART reception
UartlrqTx	UART transmission
UsrtCond1	USRT condition 1
UsrtCond2	USRT condition 2
Vldlrq	Voltage level detector
IrqAC	Acquisition chain end of conversion interrupt

Table 4-11. Interrupt source description

4.2.9 USRT (h0048-h004F)

Address	Name	7	6	5	4	3	2	1	0
h0048	RegUsrtS1	r0	r0	r0	r0	r0	r0	r0	UsrtS1 s,1,sys
h0049	RegUsrtS0	r0	r0	r0	r0	r0	r0	r0	UsrtS0 s,1,sys
h004A	RegUsrtCond1	r0	r0	r0	r0	r0	r0	r0	UsrtCond1 rc,0,sys
h004B	RegUsrtCond2	r0	r0	r0	r0	r0	r0	r0	UsrtCond2 rc,0,sys
h004C	RegUsrtCtrl	r0	r0	r0	r0	UsrtWaitS0 r,0,sys	UsrtEnWaitCond1 rw,0,sys	UsrtEnWaitS0 rw,0,sys	UsrtEnable rw,0,sys
h004D	RegUsrtBufferS1	r0	r0	r0	r0	r0	r0	r0	UsrtBufferS1 r,0,sys
h004E	RegUsrtEdgeS0	r0	r0	r0	r0	r0	r0	r0	UsrtEdgeS0 r,0,sys

Table 4-12. USRT register description

4.2.10 UART (h0050-h0057)

Address	Name	7	6	5	4	3	2	1	0
h0050	RegUartCtrl	UartEcho rw,0,sys	UartEnRx1 rw,0,sys	UartEnTx rw,0,sys	UartXRx rw,0,sys	UartXTx rw,0,sys	UartBR[2:0] rw,101,sys		
h0051	RegUartCmd	SelXtal rw,0,sys	UartEnRx2 rw,0,sys	UartRcSel[2:0] rw,000,sys			UartPM rw,0,sys	UartPE rw,0,sys	UartWL rw,1,sys
h0052	RegUartTx	UartTx[7:0] rw,0000000,sys							
h0053	RegUartTxSta	r0	r0	r0	r0	r0	r0	UartTxBusy r,0,sys	UartTxFull r,0,sys
h0054	RegUartRx	UartRx[7:0] r,00000000,sys							
h0055	RegUartRxSta	r0	r0	UartRxSErr r,0,sys	UartRxPErr r,0,sys	UartRxFErr r,0,sys	UartRxoerr rc,0,sys	UartRxBusy r,0,sys	UartRxFull r,0,sys

Table 4-13. UART register description

4.2.11 Counter/Timer/PWM registers (h0058-h005F)

Address	Name	7	6	5	4	3	2	1	0
h0058	RegCntA	CounterA[7:0] s,xxxxxxx,-							
h0059	RegCntB	CounterB[7:0] s,xxxxxxx,-							
h005A	RegCntC	CounterC[7:0] s,xxxxxxx,-							
h005B	RegCntD	CounterD[7:0] s,xxxxxxx,-							
h005C	RegCntCtrlCk	CntDckSel[1:0] rw,xx,-		CntCckSel[1:0] rw,xx,-		CntBckSel[1:0] rw,xx,-		CntAckSel[1:0] rw,xx,-	
h005D	RegCntConfig1	CntDDownUp rw,x,-	CntCDownUp rw,x,-	CntBDownUp rw,x,-	CntADownUp rw,x,-	CascadeCD rw,x,-	CascadeAB rw,x,-	CntPWM1 rw,0,sys	CntPWM0 rw,0,sys
h005E	RegCntConfig2	CapSel[1:0] rw,00,sys		CapFunc[1:0] rw,00,sys		Pwm1Size[1:0] rw,xx,-		Pwm0Size[1:0] rw,xx,-	
h005F	RegCntOn	r0	r0	r0	r0	CntDEnable rw,0,sys	CntCEnable rw,0,sys	CntBEnable rw,0,sys	CntAEnable rw,0,sys

Table 4-14. Counter/timer/PWM register description.

4.2.12 Acquisition chain registers (h0060-h0067)

Address	Name	7	6	5	4	3	2	1	0
h0060	RegAcOutLsb	OUT[7:0] r,0,sys							
h0061	RegAcOutMsb	OUT[15:8] r,0,sys							
h0062	RegAcCfg0	START w r0,0,sys	SET_NELCONV[1:0] rw,01,sys	SET_OSR[2:0] rw,010,sys			CONT rw,0,sys	r0	
h0063	RegAcCfg1	IB_AMP_ADC[1:0] rw,11,sys	IB_AMP_PGA[1:0] rw,11,sys		ENABLE[3:0] rw,0000,sys				
h0064	RegAcCfg2	FIN rw,00,sys		PGA2_GAIN[1:0] rw,00,sys	PGA2_OFFSET[3:0] rw,0000,sys				
h0065	RegAcCfg3	PGA1_GAIN Rw,0,sys	PGA3_GAIN[6:0] rw,0000000,sys						
h0066	RegAcCfg4	PGA3_OFFSET rw,0000000,sys							
h0067	RegAcCfg5	BUSY r,0,sys	DEF w r0	AMUX[4:0] rw,00000,sys				VMUX rw,0,sys	

Table 4-15. Acquisition chain register description.

4.2.13 Signal D/A registers (h0074-h0077)

Address	Name	7	6	5	4	3	2	1	0
h0074	RegDasInLsb	DasInLsb(7:0) rw,00000000,sys							
h0075	RegDasInMsb	DasInMsb(7:0) rw,00000000,sys							
h0076	RegDasCfg0	NsOrder(1:0) rw,00,sys	CodeLmax(2:0) rw,000,sys			Enable(1:0) rw,00,sys	Fin rw,0,sys		
h0077	RegDasCfg1	r0	r0	r0	r0	r0	r0	BW rw,0,sys	Inv rw,0,sys

Table 4-16. Signal D/A register description

4.2.14 Bias D/A registers (h0078-h0079)

Address	Name	7	6	5	4	3	2	1	0
h0078	RegDabIn	DabIn(7:0) rw,00000000,sys							
h0079	RegDabCfg	r0	r0	r0	r0	r0	r0	Enable(1:0) rw,00,sys	

Table 4-17. Bias D/A register description

4.2.15 Voltage multiplier (h007C)

Address	Name	7	6	5	4	3	2	1	0
h007C	RegVmultCfg0	r0	r0	r0	r0	r0	Enable rw,0,sys	Fin[1:0] rw,00,sys	

Table 4-18. VMULT register.

4.2.16 Voltage Level Detector registers (h007E-h007F)

Address	Name	7	6	5	4	3	2	1	0
h007E	RegVldCtrl	r0	r0	r0	r0	VldRange rw,0,sys	VldTune[2:0] rw,000,sys		
h007F	RegVldStat	r0	r0	r0	r0	r0	VldResult r,0,sys	VldValid r,0,sys	VldEn rw,0,sys

Table 4-19. Voltage level detector register description

4.2.17 RAM (h0080-h027F)

The 512 RAM bytes can be accessed for read and write operations. The RAM has no reset function. Variables stored in the RAM should be initialised before use since they can have any value at circuit start up.

Not Recommended for New Designs

5 System Block

5.1	Overview	5-2
5.2	Operating mode	5-2

Not Recommended for
New Designs

5.1 Overview

The XE8000 chips have three operating modes. There is the normal, the low current and the very low current modes (see Figure 5-1). The different modes are controlled by the reset and clock blocks (see the documentation of the respective blocks).

5.2 Operating mode

Start-up

All bits are reset in the design when a POR (power-on-reset) is active.

RC is enabled, Xtal is disabled and the CPU is reset (pmaddr = 0000).

If Port A is used to return from the sleep mode, all bits with **resetcold** don't change (see sleep mode).

Reset

All bits with **resetsystem** and **resetpconf** (if enabled) are reset. Clock configuration doesn't change except **cpuck**. The CPU is reset.

Active mode

This is the mode where the CPU and all peripherals can work and execute the embedded software.

Standby mode

Executing a HALT instruction moves the XE8805 into the Standby mode. The CPU is stopped, but the clocks remain active. Therefore, the enabled peripherals remain active e.g. for time keeping. A reset or an interrupt/event request (if enabled) cancels the standby mode.

Sleep mode

This is a very low-power mode because all circuit clocks and all peripherals are stopped. Only some service blocks remain active. No time-keeping is possible. Two instructions are necessary to move into sleep mode. First, the **SleepEn** (sleep enable) bit in **RegSysCtrl** has to be set to 1. The sleep mode can then be activated by setting the **Sleep** bit in **RegSysReset** to 1.

There are three possible ways to wake-up from the sleep mode:

1. The **por** (power-on-reset caused by a power-down followed by power-on). The RAM information is lost.
2. The **padreset**
3. The Port A reset combination (if the Port A is present in the product). See Port A documentation for more details.

Note: If the Port A is used to return from the sleep mode, all bits with **resetcold** don't change (**RegSysCtrl**, **RegSysReset** (except bit **sleep**), **EnExtClock** and **BiasRc** in **RegSysClock**, **RegSysRcTrim1** and **RegSysRcTrim2**). The **SleepFlag** bit in **RegSysReset**, reads back a 1 if the circuit was in sleep mode since the flag was last cleared (see reset block for more details).

Note: For a lower power consumption, disable the **BiasRc** bit in **RegSysClock** before to going to sleep mode. The start-up time of the oscillator will then be longer however.

Note: It is recommended to insert a NOP instruction after the instruction that sets the circuit in sleep mode because this instruction can be executed when the sleep mode is left using the **resetfromportA**.

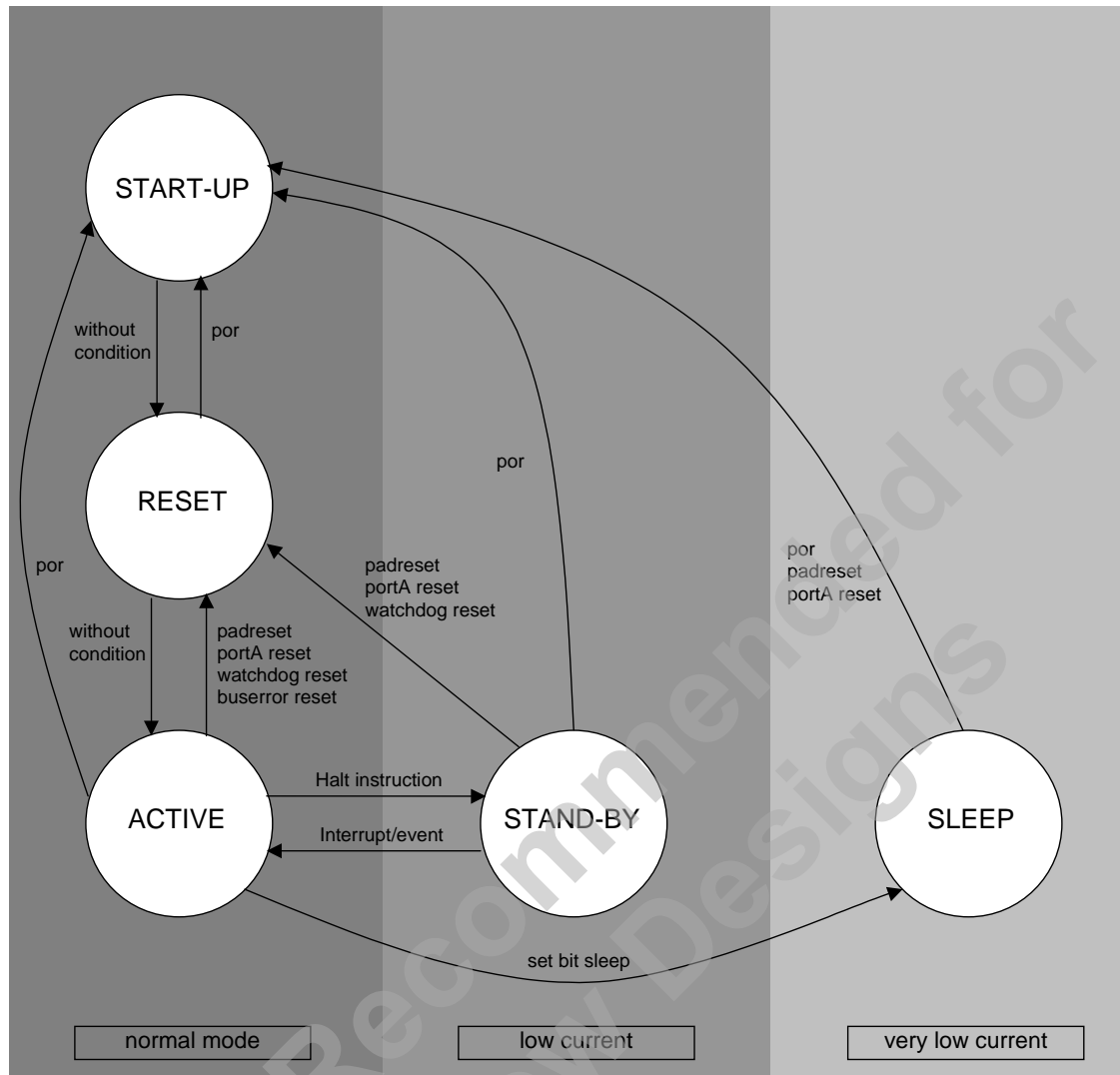

Figure 5-1. XE8805 operating modes.

6 Reset Block

6.1	Features	6-2
6.2	Overview	6-2
6.3	Register map	6-2
6.4	Reset handling capabilities	6-3
6.5	Reset source description	6-4
6.5.1	Power On Reset	6-4
6.5.2	RESET pin	6-4
6.5.3	Programmable Port A input combination	6-4
6.5.4	Watchdog reset	6-4
6.5.5	BusError reset	6-4
6.5.6	Sleep mode	6-4
6.6	Control register description and operation	6-4
6.7	Watchdog	6-5
6.8	Start-up and watchdog specifications	6-5

6.1 Features

- Power On Reset (POR)
- External reset from the RESET pin
- Programmable Watchdog timer reset
- Programmable BusError reset
- Sleep mode management
- Programmable Port A input combination reset

6.2 Overview

The reset block is the reset manager. It handles the different reset sources and distributes them through the system. It also controls the sleep mode of the circuit.

6.3 Register map

Pos.	RegSysCtrl	Rw	Reset	Function
7	SleepEn	r w	0 resetcold	enables Sleep mode 0: sleep mode is disabled 1: sleep mode is enabled
6	EnResPConf	r w	0 resetcold	enables the resetpconf signal when the resetglobal is active 0: resetpconf is disabled 1: resetpconf is enabled
5	EnBusError	r w	0 resetcold	enables reset from BusError 0: BusError reset source is disabled 1: BusError reset source is enabled
4	EnResWD	r w	0 resetcold	enables reset from Watchdog 0: Watchdog reset source is disabled 1: Watchdog reset source is enabled this bit can not be set to 0 by SW
3-0	-	r	0000	unused

Table 6-1. RegSysCtrl register.

Pos.	RegSysReset	Rw	Reset	Function
7	Sleep	rw	0 resetsystem	Sleep mode control (reads always 0)
6	-	r	0	unused
5	ResetBusError	r c	0 resetcold	reset source was BusError
4	ResetWD	r c	0 resetcold	reset source was Watchdog
3	ResetfromportA	r c	0 resetcold	reset source was Port A combination
2	ResPad	r c	0 resetcold	reset source was reset pad
1	ResPadSleep	r c	0 resetcold	reset source was reset pad in sleep mode
0	-	r	0	unused

Table 6-2. RegSysReset register

Pos.	RegSysWD	Rw	Reset	Function
7 – 4	-	r	0000	unused
3	WDKey[3]	w	0 resetcold	Watchdog Key bit 3
	WDCounter[3]	r		Watchdog counter bit 3
2	WDKey[2]	w	0 resetcold	Watchdog Key bit 2
	WDCounter[2]	r		Watchdog counter bit 2
1	WDKey[1]	w	0 resetcold	Watchdog Key bit 1
	WDCounter[1]	r		Watchdog counter bit 1
0	WDKey[0]	w	0 resetcold	Watchdog Key bit 0
	WDCounter[0]	r		Watchdog counter bit 0

Table 6-3. RegSysWD register

6.4 Reset handling capabilities

There are 5 reset sources:

- Power On Reset (POR)
- External reset from the RESET pin
- Programmable Port A input combination
- Programmable watchdog timer reset
- Programmable BusError reset on processor access outside the allocated memory map

Another reset source is the bit **Sleep** in the RegSysReset register. This source is fully controlled by software and is only used during the sleep mode.

Four internal reset signals are generated from these sources and distributed through the system:

- resetcold: is asserted on POR
- resetsystem: is asserted when resetcold or any other enabled reset source is active
- resetpconf: is asserted when resetsystem is active and if the **EnResPConf** bit in the RegSysCtrl register is set. This reset is generally used in the different ports. It allows to maintain the port configuration unchanged while the rest of the circuit is reset.
- resetsleep: is asserted when the circuit is in sleep mode

For the circuits XE8801A and XE8805A

(2) For the circuits XE8801 and XE8805

Table 6-4 shows a summary of the dependency of the internal reset signals on the various reset sources. In all the tables describing the different registers, the reset source is indicated.

Asserted reset source	Internal reset signals				
	resetsystem	resetpconf		resetsleep	resetcold
		when EnResPConf=0	when EnResPConf=1		
POR	Asserted	Asserted	Asserted	Asserted	Asserted
RESET pin (1)	Asserted	Asserted	Asserted	Asserted	Asserted
RESET pin (2)	Asserted	-	Asserted	-	-
PortA input	Asserted	-	Asserted	-	-
Watchdog	Asserted	-	Asserted	-	-
BusError	Asserted	-	Asserted	-	-
Sleep	-	-	-	Asserted	-

(1) For the circuits XE8801A and XE8805A

(2) For the circuits XE8801 and XE8805

Table 6-4. Internal reset assertion as a function of the reset source.

6.5 Reset source description

6.5.1 Power On Reset

The power on reset (POR) monitors the external supply voltage. It activates a reset on a rising edge of this supply voltage. The reset is inactivated only if the internal voltage regulator has started up. No precise voltage level detection is performed by the POR block.

6.5.2 RESET pin

The reset can be activated by applying a high input state on the RESET pin.

6.5.3 Programmable Port A input combination

A reset signal can be generated by Port A. See the description of the Port A for further information.

6.5.4 Watchdog reset

The Watchdog will generate a reset if the **EnResetWD** bit in the **RegSysCtrl** register has been set and if the watchdog is not cleared in time by the processor. See chapter 6.7 describing the watchdog for further information.

6.5.5 BusError reset

The address space is assigned as shown in the register map of the product. If the **EnBusError** bit in the **RegSysCtrl** register is set and a non-existent address is accessed by the software, a reset is generated.

6.5.6 Sleep mode

Entering the sleep mode will reset a part of the circuit. The reset is used to configure the circuit for correct wake-up after the sleep mode. If the **SleepEn** bit in the **RegSysCtrl** register has been set, the sleep mode can be entered by setting the bit **Sleep** in **RegSysReset**. During the sleep mode, the **resetsleep** signal is active. For detailed information on the sleep mode, see the system documentation.

6.6 Control register description and operation

Two registers are dedicated for reset status and control, **RegSysReset** and **RegSysCtrl**. The bits **Sleep**, and **SleepEn** are also located in those registers and are described in the chapter dedicated to the different operating modes of the circuit (system block).

The **RegSysReset** register gives information on the source which generated the last reset. It can be read at the beginning of the application program to detect if the circuit is recovering from an error or exception condition, or if the circuit is starting up normally.

- when **ResBusError** is 1, a forbidden address access generated the reset.
- when **ResWD** is 1, the watchdog generated the reset.
- when **ResPortA** is 1, a PortA combination generated the reset.
- when **ResPad** is 1, a reset pin generated the reset.
- when **ResPadSleep** is 1, a reset pin in sleep mode generated the reset.

Note: If no bit is set to 1, the reset source was the internal POR.

Note: Several bits might be set or not, if the register was not cleared in between 2 reset occurrences. Write any value in **RegSysReset** to clear it.

Note: When a reset pin wakes up the chip from the sleep mode, **ResPad** and **ResPadSleep** bits are equal at 1.

The last bit concerns the sleep mode control (see system documentation for the sleep mode description).

- when **Sleep** is set to 1, and **SleepEn** is 1, the sleep mode is entered. The bit always reads back a 0.

The **RegSysCtrl** register enables the different available reset sources and the sleep mode.

- **EnResWD** enables the reset due to the watchdog (can not be disabled once enabled).
- **EnBusError** enables the reset due to a bus error condition.
- **EnResPConf** enables the reset of the port configurations when reset by Port A, a Bus Error or the watchdog.
- **SleepEn** unlocks the **Sleep** bit. As long as **SleepEn** is 0, the **Sleep** bit has no effect.

6.7 Watchdog

The watchdog is a timer which has to be cleared at least every 2 seconds by the software to prevent a reset being generated by the timeout condition.

The watchdog can be enabled by software by setting the **EnResWD** bit in the **RegSysCtrl** register to 1. It can then only be disabled by a power on reset.

The watchdog timer can be cleared by writing consecutively the values Hx0A and Hx03 to the **RegSysWD** register. The sequence must strictly be respected to clear the watchdog.

In assembler code, the sequence to clear the watchdog is:

```
move AddrRegSysWD, #0x0A
move AddrRegSysWD, #0x03
```

Only writing Hx0A followed by Hx03 resets the WD. If some other write instruction is done to the **RegSysWD** between the writing of the Hx0A and Hx03 values, the watchdog timer will not be cleared.

It is possible to read the status of the watchdog in the **RegSysWD** register. The watchdog is a 4 bit counter with a count range between 0 and 7. The system reset is generated when the counter is reaching the value 8.

6.8 Start-up and watchdog specifications

At start-up of the circuit, the POR (power-on-reset) block generates a reset signal during t_{POR} . The circuit starts software execution after this period (see system chapter). The POR is intended to force the circuit in a correct state at start-up. For precise monitoring of the supply voltage, the voltage level detector (VLD) has to be used.

Symbol	Parameter	Min	Typ	Max	Unit	Comments
T _{POR}	POR reset duration	5		20	ms	
T _{RESET}	RESET pin reset duration	20		200	μs	3
T _{RESET}	RESET pin reset duration	5		20	ms	4
Vbat_sl_M	Supply ramp up of MTP version	20			V/ms	1
Vbat_sl_R	Supply ramp up of ROM version	0.25			V/ms	1
WDtime	Watchdog timeout period	2			s	2

Table 6-5. Electrical and timing specifications

Note: 1) The Vbat_sl defines the minimum slope required on VBAT. Correct start-up of the circuit is not guaranteed if this slope is too slow. In such a case, a delay has to be built using the RESET pin.

Note: 2) The minimal watchdog timeout period is guaranteed when the internal oscillators are used. The watchdog takes its clock from the low prescaler. In case an external clock source is used, the RC oscillator must be enabled also (**EnRC=1** in **RegSysClock**). Otherwise, the watchdog is stopped (see the clock block documentation).

Note: 3) For the circuit versions XE8801 and XE8805. Gives the time the reset is active after the falling edge of the RESET pin.

Note: 4) For the circuit versions XE8801A and XE8805A. Gives the time the reset is active after the falling edge of the RESET pin.

7 Clock Generator

7.1	Features	7-2
7.2	Overview	7-2
7.3	Register map	7-2
7.4	Interrupts and events map	7-3
7.5	Clock sources	7-4
7.5.1	RC oscillator	7-4
7.5.2	Xtal oscillator	7-6
7.5.3	External clock	7-7
7.6	Clock source selection	7-8
7.7	RegSysMisc Description	7-8
7.8	Prescalers	7-9
7.9	32 kHz frequency selector	7-9

Not Recommended for
New Designs

7.1 Features

- 3 available clock sources (RC oscillator, quartz oscillator and external clock).
- 2 divider chains: high-prescaler (8 bits) and low-prescaler (15 bits).
- CPU clock disabling in halt mode.

7.2 Overview

The XE8805 chips can work on different clock sources (RC oscillator, quartz oscillator and external clock). The clock generator block is in charge of distributing the necessary clock frequencies to the circuit. Figure 7-1 represents the functionality of the clock block.

The internal RC oscillator drives the high prescaler. This prescaler generates frequency divisions down to 1/256 of its input frequency. A 32kHz clock is generated by enabling the quartz oscillator (if present in the product) or by selecting the appropriate tap on the high prescaler. The low prescaler generates clock signals from 32kHz down to 1Hz. The clock source for the CPU can be selected from the RC oscillator, the external clock or the 32kHz clock.

7.3 Register map

pos.	RegSysClock	rw	Reset	function
7	CpuSel	rw	0 resetsleep	Select speed for cpuck, 0=RC, 1=xtal or external clock
6	Extclk	r	0 resetcold	External clock detected, 1=available
5	EnExtClock	rw	0 resetcold	Enable for external clock, 1=enabled
4	BiasRc	rw	1 resetcold	Enable Rcbias (reduces start-up time of RC).
3	ColdXtal	r	1 resetsleep	Xtal in start phase
2	ColdRC	r	1 resetsleep	RC in start phase
1	EnableXtal	rw	0 resetsleep	Enable Xtal oscillator, 0=disabled, 1=enabled
0	EnableRc	rw	1 resetsleep	Enable RC oscillator, 0=disabled, 1=enabled

Table 7-1: RegSysClock register

pos.	RegSysMisc	rw	Reset	Function
7-4	--	r	0000	Unused
3	RConPA0	rw	0 resetsleep	Start RC on PA[0], 0=disabled, 1=enabled
2	DebFast	rw	0 resetsleep	Debouncer clock speed, 0=256Hz, 1=8kHz
1	OutputCkXtal	rw	0 resetsleep	Output Xtal Clock on PB[3], 0=disabled, 1=enabled if EnXtal =1 else PB[3]=0
0	OutputCpuCk	rw	0 resetsleep	Output CPU clock on PB[2], 0=disabled, 1=enabled

Table 7-2: RegSysMisc register

pos.	RegSysPre0	rw	reset	Function
7-1	--	r	0000000	Unused
0	ResPre	w1 r0	0	Write 1 to reset low prescaler, but always reads 0

Table 7-3: RegSysPre0 register

pos.	RegSysRcTrim1	rw	reset	Function
7-4	--	r	00	Unused
5	Reserved	rw	0 resetcold	Reserved
4	RcFreqRange	rw	0 resetcold	Low/high freq. range (low=0)
3	RcFreqCoarse[3]	rw	0 resetcold	RC coarse trim bit 3
2	RcFreqCoarse[2]	rw	0 resetcold	RC coarse trim bit 2
1	RcFreqCoarse[1]	rw	0 resetcold	RC coarse trim bit 1
0	RcFreqCoarse[0]	rw	0 resetcold	RC coarse trim bit 0

Table 7-4: RegSysRTrim1 register

pos.	RegSysRcTrim2	Rw	reset	function
7-6	--	r	00	Unused
5	RcFreqFine[5]	rw	1 resetcold	RC fine trim bit 5
4	RcFreqFine[4]	rw	0 resetcold	RC fine trim bit 4
3	RcFreqFine[3]	rw	0 resetcold	RC fine trim bit 3
2	RcFreqFine[2]	rw	0 resetcold	RC fine trim bit 2
1	RcFreqFine[1]	rw	0 resetcold	RC fine trim bit 1
0	RcFreqFine[0]	rw	0 resetcold	RC fine trim bit 0

Table 7-5: RegSysRTrim2 register

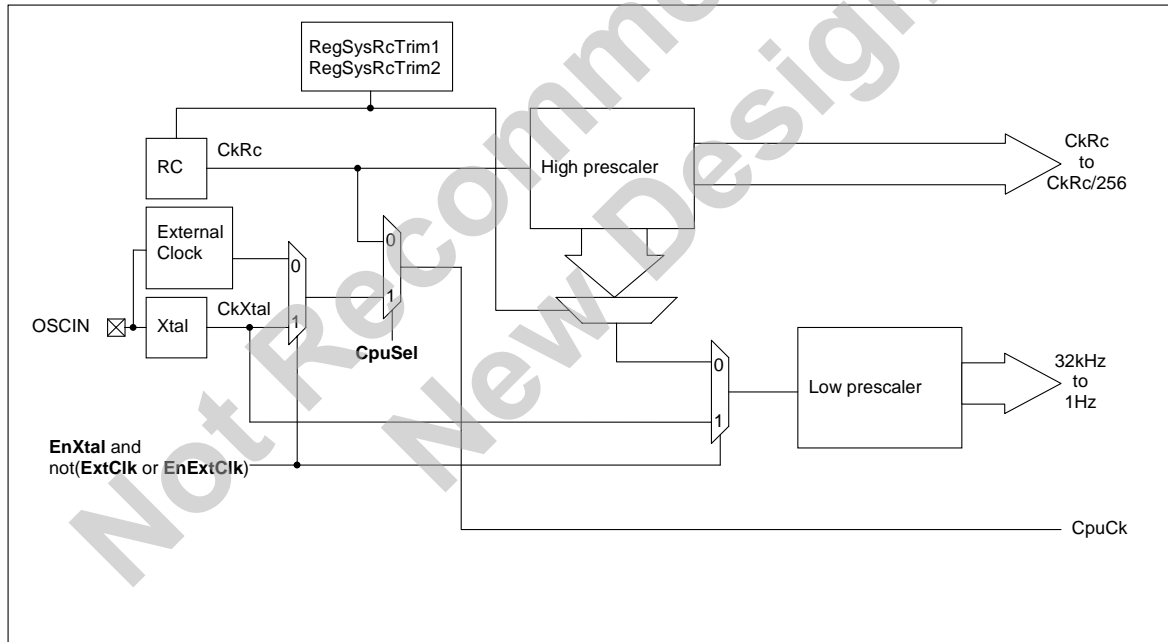

Figure 7-1. Clock block structure

7.4 Interrupts and events map

Interrupt	Interrupt source	Mapping in the interrupt manager	Mapping in the event manager
IrqPre1	Ck128Hz	RegIrqHig(6)	RegEvn(5)
IrqPre2	Ck1Hz	RegIrqMid(3)	RegEvn(1)

Table 7-6: Interrupts and events map

7.5 Clock sources

7.5.1 RC oscillator

7.5.1.1 Configuration

The RC oscillator is always turned on and selected for CPU and system operation at power-on reset and when exiting sleep mode. It can be turned off after the Xtal (quartz oscillator) has been started, after selection of the external clock or by entering sleep mode.

The RC oscillator has two frequency ranges: sub-MHz (100 kHz to 1 MHz) and above-MHz (1 MHz to 10 MHz). Inside a range, the frequency can be tuned by software for coarse and fine adjustment. See registers **RegSysRcTrim1** and **RegSysRcTrim2**.

Bit **EnableRC** in register **RegSysClock** controls the propagation of the RC clock signal and the operation of the oscillator. The user can stop the RC oscillator by resetting the bit **EnableRC**. Entering the sleep mode disables the RC oscillator.

Note: Before turning off the RC oscillator, the **cpusel** bit in **RegSysClock** must be set to one.

Note: The RC oscillator bias can be maintained while the oscillator is switched off by setting the bit **BiasRc** in **RegSysClock**. This allows a faster restart of the RC oscillator at the cost of increased power consumption when the oscillator is disabled (see section 7.5.1.3).

7.5.1.2 RC oscillator frequency tuning

The RC oscillator frequency can be set using the bits in the **RegSysRcTrim1** and **RegSysRcTrim2** registers. Figure 7-2 shows the nominal frequency of the RC oscillator as a function of these bits. The absolute value of the frequency for a given register content may change by $\pm 50\%$ from chip to chip due to the tolerances on the integrated capacitors and resistors. However, the modification of the frequency as a function of a modification of the register content is fairly precise for frequencies below 2MHz. This means that the curves in Figure 7-2 can shift up and down but that the slope remains unchanged.

The bit **RcFreqRange** modifies the oscillator frequency by a factor of 10. The upper curve in the figure corresponds to **RcFreqRange=1**.

The **RcFreqCoarse** modifies the frequency of the oscillator by a factor (**RcFreqCoarse+1**). The figure represents the frequency for 5 different values of the bits **RcFreqCoarse**: for each value the frequency is multiplied by 2.

Incrementing the **RcFreqFine** code increases the frequency by about 1.4%.

The frequency of the oscillator is therefor given by:

$$f_{RC} = f_{Rcmin} \cdot (1 + 9 \cdot RcFreqRange) \cdot (1 + RcFreqCoarse) \cdot (1.014)^{RcFreqFine}$$

with f_{Rcmin} the RC oscillator frequency if the registers are all 0. At higher frequencies, the frequency may deviate from the value predicted by the equation.

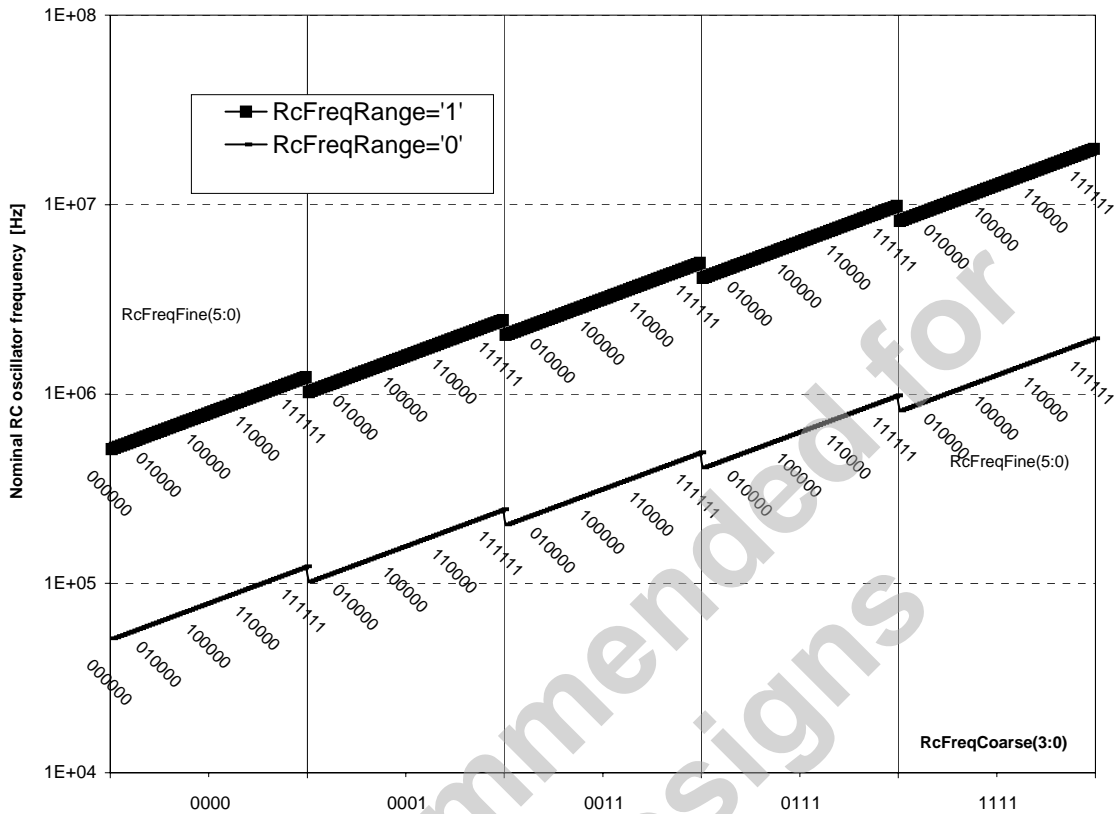

Figure 7-2. RC oscillator nominal frequency tuning.

7.5.1.3 RC oscillator specifications

symbol	description	min	typ	max	unit	Comments
f_{RCmin}	Lowest RC frequency	40	80	120	kHz	Note 1
RcFreqFine	fine tuning step		1.4	2.0	%	
RC_su	startup time		30	50	us	BiasRc=0
			3	5	us	BiasRc=1
PSRR @ DC	Supply voltage dependence		TBD		%/V	Note 2
			TBD		%/V	Note 3
$\Delta f/\Delta T$	Temperature dependence		0.1		%/°C	

Table 7-7. RC oscillator specifications

Note 1: this is the frequency tolerance when all trimming codes are 0.

Note 2: frequency shift as a function of VBAT with normal regulator function.

Note 3: frequency shift as a function of VBAT while the regulator is short-circuited to VBAT.

The tolerances on the minimal frequency and the drift with supply or temperature can be cancelled using the software DFLL (digital frequency locked loop) which uses the crystal oscillator as a reference frequency.

7.5.2 Xtal oscillator

7.5.2.1 Xtal configuration

The Xtal operates with an external crystal of 32'768 Hz.

During Xtal oscillator start-up, the first 32768 cycles are masked. The two bits **EnableXtal** and **ColdXtal** in register **RegSysClock** control the oscillator.

At power-on reset or during sleep mode, **EnableXtal** is reset and **ColdXtal** is set (Xtal oscillator is not selected at start-up). The user can start Xtal oscillator by setting **EnableXtal**. When the Xtal oscillator starts, bit **ColdXtal** is reset after 32768 cycles. Before **ColdXtal** is reset by the system, the Xtal frequency precision is not guaranteed. The Xtal oscillator can be stopped by the user by resetting bit **EnableXtal**.

When the user enters into sleep mode, the Xtal is stopped.

When an external clock is detected (**ExtClk** = 1) or the **EnExtClock** is set 1, the **EnableXtal** bit can not be set to 1.

7.5.2.2 Xtal oscillator specifications

The crystal oscillator has been designed for a crystal with the specifications given in Table 7-8. The oscillator precision can only be guaranteed for this crystal.

Symbol	Description	Min	Typ	Max	Unit	Comments
Fs	Resonance frequency		32768		Hz	
CL	CL for nominal frequency		8.2	15	pF	
Rm	Motional resistance		40	100	kΩ	
Cm	Motional capacitance	1.8	2.5	3.2	fF	
C0	Shunt capacitance	0.7	1.1	2.0	pF	
Rmp	Motional resistance of 6 th overtone (parasitic)	4	8		kΩ	
Q	Quality factor	30k	50k	400k	-	

Table 7-8. Crystal specifications.

For safe operation, low power consumption and to meet the specified precision, careful board layout is required:

Keep lines OSCIN and OSCOUT short and insert a VSS line in between them.

Connect the crystal package to VSS.

No noisy or digital lines near OSCIN or OSCOUT.

Insert guards where needed.

Respect the board specifications of Table 7-9.

Symbol	Description	Min	Typ	Max	Unit	Comments
Rh_oscin	Resistance OSCIN-VSS	10			MΩ	
Rh_oscout	Resistance OSCOUT-VSS	10			MΩ	
Rh_oscin_oscout	Resistance OSCIN-OSCOUT	50			MΩ	
Cp_oscin	Capacitance OSCIN-VSS	0.5		3.0	pF	
Cp_oscout	Capacitance OSCOUT-VSS	0.5		3.0	pF	
Cp_oscin_oscout	Capacitance OSCIN-OSCOUT	0.2		1.0	pF	

Table 7-9. Board layout specifications.

The oscillator characteristics are given in Table 7-10. The characteristics are valid only if the crystal and board layout meet the specifications above.

Symbol	Description	Min	Typ	Max	Unit	Comments
f_{xtal}	Nominal frequency		32768		Hz	
St_xtal	Start-up time		1	2	s	
Fstab	Frequency deviation	-100		300	ppm	Note 1

Table 7-10. Crystal oscillator characteristics.

Note 1. This gives the relative frequency deviation from nominal for a crystal with CL=8.2pF and within the temperature range -40°C to 85°C. The crystal tolerance, crystal aging and crystal temperature drift are not included in this figure.

7.5.3 External clock

7.5.3.1 External clock configuration

The user can provide an external clock instead of the internal oscillators. Only the CPU can use the external clock. The external clock input pin is OSCIN.

The system is configured for external clock by bit **EnExtClock** in register **RegSysClock**.

When **EnExtClock** is set to 1, the external clock is detected after 4 pulses on pin OSCIN. The **ExtClk** bit shows when the external clock is available.

Note: when using the external clock, the Xtal is not available.

7.5.3.2 External clock specification

The external clock has to satisfy the specifications in the table below. Correct behavior of the circuit can not be guaranteed if the external clock signal does not respect the specifications below.

Symbol	Description	Min	Typ	Max	Unit	Comments
F_{EXT}	External frequency clock			2	MHz	
PW_1	Pulse 1 width	0.2			μs	
PW_0	Pulse 0 width	0.2			μs	

Table 7-11. External clock specifications.

7.6 Clock source selection

There are three possible clock sources available for the CPU clock. The RC clock is always selected after power-up or after Sleep mode. The CPU clock selection is done with the bit **CpuSel** in **RegSysClock** (0= RC clock, 1= 32 kHz from Xtal if **EnableXtal** =1, **ExtClk** = 0 and **EnExtClk** = 0 else external clock).

Switching from one clock source to another is glitch free.

The next table summarizes the different clock configurations of the circuit:

Clock Sources				Clock targets			
Mode name	EnExtClk	EnableRc	EnableXtal	Cpuck ^{Note 1}		High Prescaler Clock input	Low Prescaler Clock input
				CpuSel=0	CpuSel=1		
Sleep	0	0	0	Off	Off	Off	Off
Xtal	0	0	1	Off	Xtal	Off	Xtal
RC	0	1	0	RC	RC	RC	High presc.
RC + Xtal	0	1	1	RC	Xtal	RC	Xtal
External	1	0	X	Off	External	Off	Off
RC + External	1	1	X	RC	External	RC	High presc.

Table 7-12: Table of clocking modes.

Note 1: The CPU clock can be divided by using the freq instruction (see coolrisc instruction set)

Switching from one clock source to another and stopping the unused clock source must be performed using 3 MOVE instructions to **RegSysClock**. First select the new clock source, secondly change the **CpuSel** bit and finally stop the unused one.

7.7 RegSysMisc Description

The **RConPA0** bit in **RegSysMisc** can be used to enable the RC oscillator on an event external to the circuit. If **RConPA0** is 1, the RC oscillator is enabled (**EnableRC** bit is set to 1) as soon as the value on port A pin PA[0] is equal to 1. The port A pin can be debounced (see port A documentation).

Bit **DebFast** in the **RegSysMisc** register allows to chose the debouncer clock between 256Hz and 8kHz (DebFast = 0 and DebFast = 1 respectively). The Debouncer clock is used to debounce PA inputs (see port A documentation).

Bit **OutputCkXtal** allows to show the Xtal clock on PB[3]. The **EnableXtal** bit must be set to 1 else PB[3] equals 0 (see port B documentation to set up the port B).

Bit **OutputCpuCk** allows to show the CpuClock on PB[2] (see port B documentation).

7.8 Prescalers

The clock generator block embeds two divider chains: the high prescaler and the low prescaler.

The high prescaler is made of an 8 stage dividing chain and the low prescaler of a 15 stage dividing chain.

Features:

- High prescaler can only be driven with RC clock (bit **EnableRc** have to be set, see Table 7-12).
- Low prescaler can be driven from the high prescaler or directly with the Xtal clock when bit **EnableXtal** is set to 1, bit **EnExtClock** is set to 0 and **ExtClk** is equal at 0.
- Bit **ResPre** in the **RegSysPre0** register allows to reset synchronously the low prescaler, the low prescaler is also automatically cleared when bit **EnableXtal** is set. Both dividing chains are reset asynchronously by the *resetsleep* signal.
- Bit **ColdXtal**=1 indicates the Xtal is in its start up phase. It is active for 37268 Xtal cycles after setting **EnableXtal**.

7.9 32 kHz frequency selector

A decoder is used to select from the high prescaler the frequency tap that is the closest to 32 kHz to operate the low prescaler when the Xtal is not running. In this case, the RC oscillator frequency of $\pm 50\%$ will also be valid for the low prescaler frequency outputs.

8 IRQ - Interrupt handler

8.1	Features	8-2
8.2	Overview	8-2
8.3	Register map	8-2

Not Recommended for
New Designs

8.1 Features

The XE8000 chips support 24 interrupt sources, divided into 3 levels of priority.

8.2 Overview

A CPU interruption is generated and memorized when an interrupt becomes active. The 24 interrupt sources are divided into 3 levels of priority: High (8 interrupt sources), Mid (8 interrupt sources), and Low (8 interrupt sources). Those 3 levels of priority are directly mapped to those supported by the CoolRisc® (IN0, IN1 and IN2; see CoolRisc® documentation for more information).

ReglrqHig, **ReglrqMid**, and **ReglrqLow** are 8-bit registers containing flags for the interrupt sources. Those flags are set when the interrupt is enabled (i.e. if the corresponding bit in the registers **ReglrqEnHig**, **ReglrqEnMid** or **ReglrqEnLow** is set) and a rising edge is detected on the corresponding interrupt source.

Once memorized, an interrupt flag can be cleared by writing a '1' in the corresponding bit of **ReglrqHig**, **ReglrqMid** or **ReglrqLow**. Writing a '0' does not modify the flag. To definitively clear the interrupt, one has to clear the CoolRisc interrupt in the CoolRisc status register. All interrupts are automatically cleared after a reset.

Two registers are provided to facilitate the writing of interrupt service software. **ReglrqPriority** contains the number of the highest priority interrupt set (its value is 0xFF when no interrupt is set). **ReglrqIrq** indicates the priority level of the current interrupts. **ReglrqIrq** and **ReglrqPriority**'s values are dependent upon the memorized state of the interrupts (as reflected in flags in **ReglrqHig**, **ReglrqMid** and **ReglrqLow**).

8.3 Register map

pos.	ReglrqHig	rw	reset	function
7	ReglrqHig[7]	r c1	0 resetsystem	interrupt #23 (high priority) clear interrupt #23 when 1 is written
6	ReglrqHig[6]	r c1	0 resetsystem	interrupt #22 (high priority) clear interrupt #22 when 1 is written
5	ReglrqHig[5]	r c1	0 resetsystem	interrupt #21 (high priority) clear interrupt #21 when 1 is written
4	ReglrqHig[4]	r c1	0 resetsystem	interrupt #20 (high priority) clear interrupt #20 when 1 is written
3	ReglrqHig[3]	r c1	0 resetsystem	interrupt #19 (high priority) clear interrupt #19 when 1 is written
2	ReglrqHig[2]	r c1	0 resetsystem	interrupt #18 (high priority) clear interrupt #18 when 1 is written
1	ReglrqHig[1]	r c1	0 resetsystem	interrupt #17 (high priority) clear interrupt #17 when 1 is written
0	ReglrqHig[0]	r c1	0 resetsystem	interrupt #16 (high priority) clear interrupt #16 when 1 is written

Table 8-1: **ReglrqHig**

pos.	ReglrqMid	rw	reset	function
7	ReglrqMid[7]	r c1	0 resetsystem	interrupt #15 (mid priority) clear interrupt #15 when 1 is written
6	ReglrqMid[6]	r c1	0 resetsystem	interrupt #14 (mid priority) clear interrupt #14 when 1 is written
5	ReglrqMid[5]	r c1	0 resetsystem	interrupt #13 (mid priority) clear interrupt #13 when 1 is written
4	ReglrqMid[4]	r c1	0 resetsystem	interrupt #12 (mid priority) clear interrupt #12 when 1 is written
3	ReglrqMid[3]	r c1	0 resetsystem	interrupt #11 (mid priority) clear interrupt #11 when 1 is written
2	ReglrqMid[2]	r c1	0 resetsystem	interrupt #10 (mid priority) clear interrupt #10 when 1 is written
1	ReglrqMid[1]	r c1	0 resetsystem	interrupt #9 (mid priority) clear interrupt #9 when 1 is written
0	ReglrqMid[0]	r c1	0 resetsystem	interrupt #8 (mid priority) clear interrupt #8 when 1 is written

Table 8-2: **ReglrqMid**

pos.	ReglrqLow	rw	reset	function
7	ReglrqLow[7]	r c1	0 resetsystem	interrupt #7 (low priority) clear interrupt #7 when 1 is written
6	ReglrqLow[6]	r c1	0 resetsystem	interrupt #6 (low priority) clear interrupt #6 when 1 is written
5	ReglrqLow[5]	r c1	0 resetsystem	interrupt #5 (low priority) clear interrupt #5 when 1 is written
4	ReglrqLow[4]	r c1	0 resetsystem	interrupt #4 (low priority) clear interrupt #4 when 1 is written
3	ReglrqLow[3]	r c1	0 resetsystem	interrupt #3 (low priority) clear interrupt #3 when 1 is written
2	ReglrqLow[2]	r c1	0 resetsystem	interrupt #2 (low priority) clear interrupt #2 when 1 is written
1	ReglrqLow[1]	r c1	0 resetsystem	interrupt #1 (low priority) clear interrupt #1 when 1 is written
0	ReglrqLow[0]	r c1	0 resetsystem	interrupt #0 (low priority) clear interrupt #0 when 1 is written

Table 8-3: **ReglrqLow**

pos.	ReglrqEnHig	rw	reset	function
7	ReglrqEnHig[7]	rw	0 resetsystem	1= enable interrupt #23
6	ReglrqEnHig[6]	rw	0 resetsystem	1= enable interrupt #22
5	ReglrqEnHig[5]	rw	0 resetsystem	1= enable interrupt #21
4	ReglrqEnHig[4]	rw	0 resetsystem	1= enable interrupt #20
3	ReglrqEnHig[3]	rw	0 resetsystem	1= enable interrupt #19
2	ReglrqEnHig[2]	rw	0 resetsystem	1= enable interrupt #18
1	ReglrqEnHig[1]	rw	0 resetsystem	1= enable interrupt #17
0	ReglrqEnHig[0]	rw	0 resetsystem	1= enable interrupt #16

Table 8-4: **ReglrqEnHig**

pos.	ReglRqEnMid	rw	reset	function
7	ReglRqEnMid[7]	rw	0 resetsystem	1= enable interrupt #15
6	ReglRqEnMid[6]	rw	0 resetsystem	1= enable interrupt #14
5	ReglRqEnMid[5]	rw	0 resetsystem	1= enable interrupt #13
4	ReglRqEnMid[4]	rw	0 resetsystem	1= enable interrupt #12
3	ReglRqEnMid[3]	rw	0 resetsystem	1= enable interrupt #11
2	ReglRqEnMid[2]	rw	0 resetsystem	1= enable interrupt #10
1	ReglRqEnMid[1]	rw	0 resetsystem	1= enable interrupt #9
0	ReglRqEnMid[0]	rw	0 resetsystem	1= enable interrupt #8

 Table 8-5: **ReglRqEnMid**

pos.	ReglRqEnLow	rw	reset	function
7	ReglRqEnLow[7]	rw	0 resetsystem	1= enable interrupt #7
6	ReglRqEnLow[6]	rw	0 resetsystem	1= enable interrupt #6
5	ReglRqEnLow[5]	rw	0 resetsystem	1= enable interrupt #5
4	ReglRqEnLow[4]	rw	0 resetsystem	1= enable interrupt #4
3	ReglRqEnLow[3]	rw	0 resetsystem	1= enable interrupt #3
2	ReglRqEnLow[2]	rw	0 resetsystem	1= enable interrupt #2
1	ReglRqEnLow[1]	rw	0 resetsystem	1= enable interrupt #1
0	ReglRqEnLow[0]	rw	0 resetsystem	1= enable interrupt #0

 Table 8-6: **ReglRqEnLow**

pos.	ReglRqPriority	rw	reset	function
7-0	ReglRqPriority	r	11111111 resetsystem	code of highest priority set

 Table 8-7: **ReglRqPriority**

pos.	ReglRqIrq	rw	Reset	function
7-3	-	r	00000	unused
2	IrqHig	r	0 resetsystem	one or more high priority interrupt is set
1	IrqMid	r	0 resetsystem	one or more mid priority interrupt is set
0	IrqLow	r	0 resetsystem	one or more low priority interrupt is set

 Table 8-8: **ReglRqIrq**

9 Event Handler

9.1	Features	9-2
9.2	Overview	9-2
9.3	Register map	9-2

Not Recommended for
New Designs

9.1 Features

The XE8000 chips support 8 event sources, divided into 2 levels of priority.

9.2 Overview

A CPU event is generated and memorized when an event source becomes active. The 8 event sources are divided into 2 levels of priority: High (4 event sources) and Low (4 event sources). Those 2 levels of priority are directly mapped to those supported by the CoolRisc (EV0 and EV1; see CoolRisc documentation for more information).

RegEvn is an 8-bit register containing flags for the event sources. Those flags are set when the event is enabled (i.e. if the corresponding bit in the registers **RegEvnEn** is set) and a rising edge is detected on the corresponding event source.

Once memorized, writing a '1' in the corresponding bit of **RegEvn** clears an event flag. Writing a '0' does not modify the flag. All interrupts are automatically cleared after a reset.

Two registers are provided to facilitate the writing of event service software. **RegEvnPriority** contains the number of the highest priority event set (its value is 0xFF when no event is set). **RegEvnEvn** indicates the priority level of the current interrupts. **RegEvnEvn** and **RegEvnPriority**'s values are dependent upon the memorized state of the events (as reflected in flags in **RegEvn**).

9.3 Register map

pos.	RegEvn	rw	reset	function
7	RegEvn[7]	r c1	0 resetsystem	event #7 (high priority) clear event #7 when written 1
6	RegEvn[6]	r c1	0 resetsystem	event #6 (high priority) clear event #6 when written 1
5	RegEvn[5]	r c1	0 resetsystem	event #5 (high priority) clear event #5 when written 1
4	RegEvn[4]	r c1	0 resetsystem	event #4 (high priority) clear event #4 when written 1
3	RegEvn[3]	r c1	0 resetsystem	event #3 (low priority) clear event #3 when written 1
2	RegEvn[2]	r c1	0 resetsystem	event #2 (low priority) clear event #2 when written 1
1	RegEvn[1]	r c1	0 resetsystem	event #1 (low priority) clear event #1 when written 1
0	RegEvn[0]	r c1	0 resetsystem	event #0 (low priority) clear event #0 when written 1

Table 9-1: **RegEvn**

pos.	RegEvnEn	rw	reset	function
7	RegEvnEn[7]	rw	0 resetsystem	1= enable event #7
6	RegEvnEn[6]	rw	0 resetsystem	1= enable event #6
5	RegEvnEn[5]	rw	0 resetsystem	1= enable event #5
4	RegEvnEn[4]	rw	0 resetsystem	1= enable event #4
3	RegEvnEn[3]	rw	0 resetsystem	1= enable event #3
2	RegEvnEn[2]	rw	0 resetsystem	1= enable event #2
1	RegEvnEn[1]	rw	0 resetsystem	1= enable event #1
0	RegEvnEn[0]	rw	0 resetsystem	1= enable event #0

 Table 9-2: **RegEvnEn**

pos.	RegEvnPriority	rw	reset	function
7-0	RegEvnPriority	r	11111111 resetsystem	code of highest event set

 Table 9-3: **RegEvnPriority**

pos.	RegEvnEvn	rw	reset	function
7-2	-	r	00000	unused
1	EvnHig	r	0 resetsystem	one or more high priority event is set
0	EvnLow	r	0 resetsystem	one or more low priority event is set

 Table 9-4: **RegEvnEvn**

10 Low Power RAM

10.1	Features	10-2
10.2	Overview	10-2
10.3	Register map	10-2

Not Recommended for
New Designs

10.1 Features

- Low power RAM locations.

10.2 Overview

In order to save power consumption, 8 8-bit registers are provided in page 0. These memory locations should be reserved for often-updated variables. Accessing these register locations requires much less power than the other general purpose RAM locations.

10.3 Register map

pos.	Reg00	rw	reset	function
7-0	Reg00	rw	XXXXXXXX	low-power data memory

Table 10-1: Reg00

pos.	Reg01	rw	reset	function
7-0	Reg01	rw	XXXXXXXX	low-power data memory

Table 10-2: Reg01

pos.	Reg02	rw	reset	function
7-0	Reg02	rw	XXXXXXXX	low-power data memory

Table 10-3: Reg02

pos.	Reg03	rw	reset	function
7-0	Reg03	rw	XXXXXXXX	low-power data memory

Table 10-4: Reg03

pos.	Reg04	rw	reset	function
7-0	Reg04	rw	XXXXXXXX	low-power data memory

Table 10-5: Reg04

pos.	Reg05	rw	reset	function
7-0	Reg05	rw	XXXXXXXX	low-power data memory

Table 10-6: Reg05

pos.	Reg06	rw	reset	function
7-0	Reg06	rw	XXXXXXXX	low-power data memory

Table 10-7: Reg06

pos.	Reg07	rw	reset	function
7-0	Reg07	rw	XXXXXXXX	low-power data memory

Table 10-8: Reg07

11 Port A

11.1	Features	11-2
11.2	Overview	11-2
11.3	Register map	11-3
11.4	Interrupts and events map	11-3
11.5	Port A (PA) Operation	11-4
11.6	Port A electrical specification	11-5

Not Recommended for
New Designs

11.1 Features

- Input port, 8 bits wide
- Each bit can be set individually for debounced or direct input
- Each bit can be set individually for pull-up or not
- Each bit is an interrupt request source on the rising or falling edge
- A system reset can be generated on an input pattern
- PA[0] and PA[1] can generate two events for the CPU, individually maskable
- PA[0] to PA[3] can be used as clock inputs for the counters/timers/PWM (product dependent)
- PA[0] can be used to enable the RC oscillator

11.2 Overview

Port A is a general purpose 8 bit wide digital input port, with interrupt capability. Figure 11-1 shows its structure.

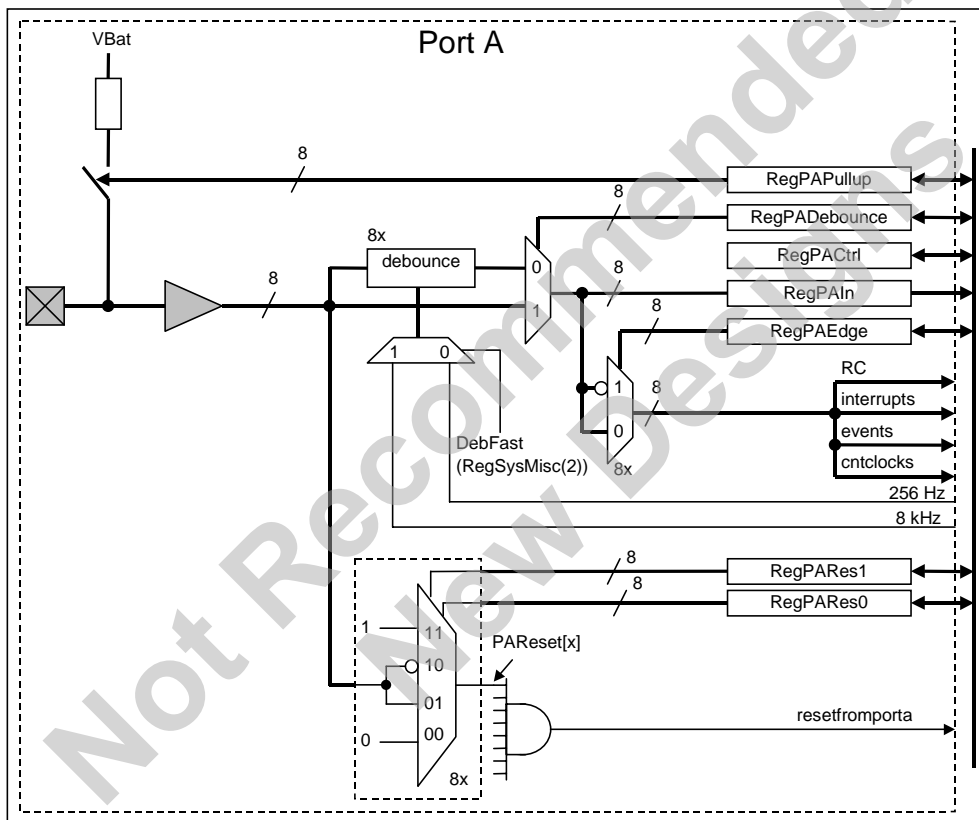

Figure 11-1:structure of Port A

11.3 Register map

There are six registers in the Port A (PA), namely RegPAIn, RegPADebounce, RegPAEdge, RegPAPullup, RegPARes0 and RegPARes1. Table 11-1 to Table 11-6 show the mapping of control bits and functionality.

pos.	RegPAIn	rw	reset	description
7:0	PAIn[7:0]	r		pad PA[7] to PA[0] input value

Table 11-1: RegPAIn

pos.	RegPADebounce	rw	reset	description
7:0	PADebounce[7:0]	r w	00000000 resetpconf	PA[7] to PA[0] 1: debounce enabled 0: debounce disabled

Table 11-2: RegPADebounce

pos.	RegPAEdge	rw	reset	description
7:0	PAEdge[7:0]	r w	00000000 resetsystem	PA[7] to PA[0] edge configuration 0: positive edge 1: negative edge

Table 11-3: RegPAEdge

pos.	RegPAPullup	rw	reset	description
7:0	PAPullup[7:0]	r w	00000000 resetpconf	PA[7] to PA[0] pullup enable 0: pullup disabled 1: pullup enabled

Table 11-4: RegPAPullup

pos.	RegPARes0	rw	Reset	description
7:0	PARes0[7:0]	r w	00000000 resetsystem	PA[7] to PA[0] reset configuration

Table 11-5: RegPARes0

pos.	RegPARes1	rw	reset	Description
7:0	PARes1[7:0]	r w	00000000 resetsystem	PA[7] to PA[0] reset configuration

Table 11-6: RegPARes

11.4 Interrupts and events map

Interrupt source	Default mapping in the interrupt manager	Default mapping in the event manager
pa_irqbus[5]	RegIrqMid[5]	
pa_irqbus[4]	RegIrqMid[4]	
pa_irqbus[1]	RegIrqMid[1]	RegEvn[4]
pa_irqbus[0]	RegIrqMid[0]	RegEvn[0]
pa_irqbus[7]	RegIrqLow[7]	
pa_irqbus[6]	RegIrqLow[6]	
pa_irqbus[3]	RegIrqLow[3]	
pa_irqbus[2]	RegIrqLow[2]	

11.5 Port A (PA) Operation

The Port A input status (debounced or not) can be read from **RegPAin**.

Debounce mode:

Each bit in Port A can be individually debounced by setting the corresponding bit in **RegPADebounce**. After reset, the debounce function is disabled. After enabling the debouncer, the change of the input value is accepted only if the input value is identical at two consecutive sampling on the rising edge of the selected clock. Selection of the clock is done by the bit **DebFast** in Register **RegSysMisc** (see clock block documentation for more precision on the frequency).

DebFast	Clock filter
0	256 Hz
1	8 kHz

Table 11-7: debounce frequency selection

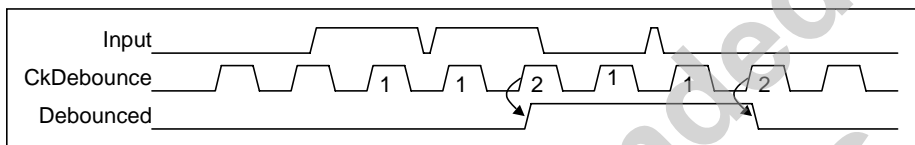

Figure 11-2: digital debouncer

Pull-ups:

When the corresponding bit in **RegPAPullup** is set to 0, the inputs are floating (pull-up resistors are disconnected). When the corresponding bit in **RegPAPullup** is set to 1, a pull-up resistor is connected to the input pin. Port A starts up with the pull-up resistors disconnected.

Port A as an interrupt source:

Each Port A input is an interrupt request source and can be set on rising or falling edge with the corresponding bit in **RegPAEdge**. After reset, the rising edge is selected for interrupt generation by default. The interrupt source can be debounced by setting register **RegPADebounce**.

Note: care must be taken when modifying **RegPAEdge** because this register performs an edge selection. The change of this register may result in a transition which may be interpreted as a valid interruption.

Port A as an event source:

The interrupt signals of the pins PA[0] and PA[1] are also available as events on the event controller.

Port A as a clock source (product dependent):

Images of the PA[0] to PA[3] input ports (debounced or not) are available as clock sources for the counter/timer/PWM peripheral (see the counter block documentation for more information).

Port A as a reset source:

Port A can be used to generate a system reset by placing a predetermined word on Port A externally. The reset is built using a logical and of the 8 PARes[x] signals:

$$\text{resetfromportA} = \text{PAReset}[7] \text{ AND } \text{PAReset}[6] \text{ AND } \text{PAReset}[5] \text{ AND } \dots \text{ AND } \text{PAReset}[0]$$

PAReset[x] is itself a logical function of the corresponding pin PA[x]. One of four logical functions can be selected for each pin by writing into two registers **RegPARes0** and **RegPARes1** as shown in Table 11-8.

PARes1[x]	PARes0[x]	PAReset[x]
0	0	0
0	1	PA[x]
1	0	not(PA[x])
1	1	1

Table 11-8: Selection bits for reset signal

A reset from Port A can be inhibited by placing a 0 on both **PARes1[x]** and **PARes0[x]** for at least 1 pin. Setting both **PARes1[x]** and **PARes0[x]** to 1, makes the reset independent of the value on the corresponding pin. Setting both registers to hFF, will reset the circuit independent from the Port A input value. This makes it possible to do a software reset.

Note: depending of the value of PA[0] to PA[7], the change of **RegPARes0** and **RegPARes1** can cause a reset. Therefore it is safe to have always one (RegPARes0[x], RegPARes1[x]) equal to '00' during the setting operations.

Port A as a RC enable:

PA[0] can be used to enable the RC oscillator. When **RConPA0** bit in **RegSysMisc** is set to 1 and the value of PA[0] (debounced or not) is equal to 1, the **EnRc** bit in **RegSysClock** is automatically set to 1.

11.6 Port A electrical specification

Sym	description	min	typ	max	unit	Comments
V _{INH}	Input high voltage	0.7*VBAT		VBAT	V	VBAT≥2.4V
V _{INL}	Input low voltage	VSS		0.2*VBAT	V	VBAT≥2.4V
R _{PU}	Pull-up resistance	20	50	80	kΩ	
C _{in}	Input capacitance		3.5		pF	Note 1

Note 1: this value is indicative only since it depends on the package.

Table 11-9. Port A electrical specification.

12 Port B

12.1	Features	12-2
12.2	Overview	12-2
12.3	Register map	12-2
12.4	Port B capabilities	12-3
12.5	Port B analog capability	12-3
12.5.1	Port B analog configuration	12-3
12.5.2	Port B analog function specification	12-4
12.6	Port B function capability	12-4
12.7	Port B digital capabilities	12-5
12.7.1	Port B digital configuration	12-5
12.7.2	Port B digital function specification	12-6

Not Recommended for
New Designs

12.1 Features

- Input / output / analog port, 8 bits wide
- Each bit can be set individually for input or output
- Each bit can be set individually for open-drain or push-pull
- Each bit can be set individually for pull-up or not (for input or open-drain mode)
- In open-drain mode, pull-up is not active when corresponding pad is set to zero
- The 8 pads can be connected by pairs to four internal analog lines (4 line analog bus)
- Two internal freq. (cpuck and 32 kHz) can be output on PB[2] and PB[3]

Product dependant:

- Two PWM signal can be output on pads PB[0] and PB[1]
- The synchronous serial interface (USRT) uses pads PB[5], PB[4]
- The UART interface uses pads PB[6] and PB[7] for Tx and Rx

12.2 Overview

Port B is a multi-purpose 8 bit Input/output port. In addition to digital functions, all pins can be used for analog signals. All port terminals can be selected by pairs as digital input or output or as analog to share one of four possible analog lines.

12.3 Register map

Pos.	RegPBOut	rw	reset	description in digital mode	description in analog mode
7-0	PBOut[7-0]	r w	0 resetpconf	Pad PB[7-0] output value	Analog bus selection for pad PB[7-0]

Table 12-1: **RegPBOut**

Pos.	RegPBIn	rw	reset	description in digital mode	description in analog mode
7-0	PBIn[7-0]	r w		Pad PB[7-0] input status	Unused

Table 12-2: **RegPBIn**

Pos.	RegPBDir	rw	reset	description in digital mode	description in analog mode
7-0	PBDir [7-0]	r w	0 resetpconf	Pad PB[7-0] direction (0=input)	Analog bus selection for pad PB[7-0]

Table 12-3: **RegPBDir**

Pos.	RegPBOpen	rw	reset	description in digital mode	description in analog mode
7-0	PBOpen[7-0]	r w	0 resetpconf	Pad PB[7-0] open drain (1 = open drain)	Unused

Table 12-4: **RegPBOpen**

Pos.	RegPBPullup	rw	reset	description in digital mode	description in analog mode
7-0	PBPullup[7]	r w	0 resetpconf	Pull-up for pad PB[7-0] (1=active)	Connect pad PB[7-0] on selected ana bus

Table 12-5: **RegPBPullup**

Pos.	RegPBAna	rw	reset	description in digital mode	description in analog mode
7-4	--	r	0000	Unused	Unused
3	PBAna [3]	r w	0 resetpconf	Set PB[7:6] in analog mode	Set PB[7:6] in analog mode
2	PBAna [2]	r w	0 resetpconf	Set PB[5:4] in analog mode	Set PB[5:4] in analog mode
1	PBAna [1]	r w	0 resetpconf	Set PB[3:2] in analog mode	Set PB[3:2] in analog mode
0	PBAna [0]	r w	0 resetpconf	Set PB[1:0] in analog mode	Set PB[1:0] in analog mode

Table 12-6: **RegPBAna**

Note: Depending on the status of the **EnResPConf** bit in **RegSysCtrl**, the reset conditions of the registers are different. See the reset block documentation for more details on the resetpconf signal.

12.4 Port B capabilities

Port B name	usage (priority)		
	analog (high)	functions (medium)	digital (low) (default)
PB[7]	analog	uart Rx	I/O
PB[6]		uart Tx	I/O
PB[5]	analog	usrt S1	I/O
PB[4]		usrt S0	I/O
PB[3]	analog	32 kHz	I/O
PB[2]		clock CPU	I/O
PB[1]	analog	PWM1 Counter C (C+D)	I/O
PB[0]		PWM0 Counter A (A+B)	I/O

Table 12-7: Different Port B functionality

Table 12-7 shows the different usage that can be made of the port B with the order of priority. If a pair of pins is selected to be analog, it overwrites the function and digital set-up. If the pin is not selected as analog, but a function is enabled, it overwrites the digital set-up. If neither the analog nor function are selected for a pin, it is used as an ordinary digital I/O. This is the default configuration at start-up.

12.5 Port B analog capability

12.5.1 Port B analog configuration

Port B terminals can be attached to a 4 line analog bus by setting the **PBAna[x]** bits to 1 in the **RegPBAna** register.

The other registers then define the connection of these 4 analog lines to the different pads of Port B. This can be used to implement a simple LCD driver or A/D converter. Analog switching is available only when the circuit is powered with sufficient voltage (see specification below). Below the specified supply voltage, only voltages that are close to VSS or VBAT can be switched.

When **PBAna[x]** is set to 1, a pair of Port B terminals is switched from digital I/O mode to analog mode. The usage of the registers **RegPBPullup**, **RegPBOut** and **RegPBDir** define the analog configuration (see Table 12-8).

When **PBAna[x] = 1**, then **PBPullup[x]** connects the pin to the analog bus. **PBDir[x]** and **PBPOut[x]** select which of the 4 analog lines is used. For odd values of x, the selection bits are in the register **RegPBOut** (see Table 12-8). For even values of x, the selection bits are in the register **RegPBDir** (see Table 12-9).

if x is odd, PBOut[x, x-1]	PBPullup[x]	PB[x] selection on
00	1	analog line 0
01	1	analog line 1
10	1	analog line 2
11	1	analog line 3
XX	0	High impedance

Table 12-8: Selection of the analog lines for PB[x] when x is odd and **PBAna[x] = 1**

if x is even, PBDir[x+1, x]	PBPullup[x]	PB[x] selection on
00	1	analog line 0
01	1	analog line 1
10	1	analog line 2
11	1	analog line 3
XX	0	High impedance

Table 12-9: Selection of the analog lines for PB[x] when x is even and **PBAAna[x] = 1**

Example:

Set the pads PB[2] and PB[3] on the analog line 3. (the values X depend on the configuration of others pads)

- apply high impedance in the analog mode (move RegPBPullup,#0bXXXX00XX)
- go to analog mode (move RegPBAAna,#0bXXXXXX1X)
- select the analog line3 (move RegPBDir,#0bXXXX11XX and move RegPBOut,#0bXXXX11XX)
- connect the analog line to the pins (move RegPBPullup,#0bXXXX11XX)

12.5.2 Port B analog function specification

The table below defines the on-resistance of the switches between the pin and the analog bus for different conditions. The series resistance between 2 pins of Port B connected to the same analog line is twice the resistance given in the table.

sym	description	min	typ	max	unit	Comments
Ron	switch resistance			11	kΩ	Note 1
Ron	switch resistance			15	kΩ	Note 2
Cin	input capacitance (off)		3.5		pF	Note 3
Cin	input capacitance (on)		4.5		pF	Note 4

Table 12-10. Analog input specifications.

Note 1: This is the series resistance between the pad and the analog line in 2 cases

1. VBAT ≥ 2.4V and the VMULT peripheral is present on the circuit and enabled.
2. VBAT ≥ 3.0V and the VMULT peripheral is not present on the circuit.

Note 2: This is the series resistance in case VBAT ≥ 2.8V and the peripheral VMULT is not present on the circuit.

Note 3: This is the input capacitance seen on the pin when the pin is not connected to an analog line. This value is indicative only since it is product and package dependent.

Note 4: This is the input capacitance seen on the pin when the pin is connected to an analog line and no other pin is connected to the same analog line. This value is indicative only since it is product and package dependent.

12.6 Port B function capability

The Port B can be used for different functions implemented by other peripherals. The description below is applicable only in so far the circuit contains these peripherals.

When the counters are used to implement a PWM function (see the documentation of the counters), the PB[0] and PB[1] terminals are used as outputs (PB[0] is used if **CntPWM0** in **RegCntConfig1** is set to 1, PB[1] is used if **CntPWM1** in **RegCntConfig1** is set to 1) and the PWM generated values overwrite the values written in **RegPBout**. However, **PBDir(0)** and **PBDir(1)** are not automatically overwritten and have to be set to 1.

If **OutputCkXtal** is set in **RegSysMisc**, the Xtal clock is output on PB[3] (EnableXtal in RegSysClock must be set to 1). This overrides the value contained in **PBOut(3)**. However, **PBDir(3)** must be set to 1. The duty cycle of the clock signal is about 50%.

Similarly, if **OutputCkCpu** is set in **RegSysMisc**, the CPU frequency is output on PB[2]. This overrides the value contained in **PBOut(2)**. However, **PBDir(2)** must be set to 1.

The frequency of the CPU clock depends on the selection of the **CpuSel** bit in the **RegSysClock** register (see `clock_gen_ff`).

Pins PB[5] and PB[4] can be used for S1 and S0 of the USRT (see USRT documentation) when the **UsrtEnable** bit is set in **RegUsrtCtrl**. The PB[5] and PB[4] then become open-drain. This overrides the values contained in **PBOpen(5:4)**, **PBOut(5:4)** and **PBDir(5:4)**. If there is no external pull-up resistor on these pins, internal pull-ups should be selected by setting **PBPullup(5:4)**. When S0 is an output, the pin PB[4] takes the value of **UsrtS0** in **RegUrstS0**. When S1 is an output, the pin PB[5] takes the value of **UsrtS1** in **RegUrstS1**.

Pins PB[6] and PB[7] can be used by the UART (see UART documentation). When **UartEnTx** in **RegUartCtrl** is set to 1, PB[6] is used as output signal Tx. When **UartEnRx** in **RegUartCtrl** is set to 1, PB[7] is used as input signal Rx. This overrides the values contained in **PBOut(7:6)** and **PBDir(7:6)**.

12.7 Port B digital capabilities

12.7.1 Port B digital configuration

The direction of each bit within Port B (input only or input/output) can be individually set using the **RegPBDir** register. If **PBDir[x] = 1**, both the input and output buffer are active on the corresponding Port B. If **PBDir[x] = 0**, the corresponding Port B pin is an input only and the output buffer is in high impedance. After reset (`resetpconf`) Port B is in input only mode (**PBDir[x]** are reset to 0).

The input values of Port B are available in **RegPBIn** (read only). Reading is always direct - there is no debounce function in Port B. In case of possible noise on input signals, a software debouncer with polling or an external hardware filter have to be realized. The input buffer is also active when the port is defined as output and allows to read back the effective value on the pin.

Data stored in **RegPBOut** are output at Port B if **PBDir[x]** is 1. The default value after reset is low (0).

When a pin is in output mode (**PBDir[x]** is set to 1), the output can be a conventional CMOS (Push-Pull) or a N-channel Open-drain, driving the output only low. By default, after reset (`resetpconf`) the **PBOpen[x]** in **RegPBOpen** is cleared to 0 (push-pull). If **PBOpen[x]** in **RegPBOpen** is set to 1 then the internal P transistor in the output buffer is electrically removed and the output can only be driven low (**PBOut[x]=0**). When **PBOut[x]=1**, the pin is high impedance. The internal pull-up or an external pull-up resistor can be used to drive the pin high.

Note: Because the P transistor actually exists (this is not a real Open-drain output) the pull-up range is limited to $VDD + 0.2V$ (avoid forward bias the P transistor / diode).

Each bit can be set individually for pull-up or not using register **RegPBPullup**. Input is pulled up when its corresponding bit in this register is set to 1. Default status after (`resetpconf`) is 0, which means without pull up. To limit power consumption, pull-up resistors are only enabled when the associated pin is either a digital input or an N-channel open-drain output with the pad set to 1. In the other cases (push-pull output or open-drain output driven low), the pull up resistors are disabled independent of the value in **RegPBPullup**.

After power-on reset, the Port B is configured as an input port without pull-up.

The input buffer is always active, except in analog mode. This means that the Port B input should be a valid digital value at all times unless the pin is set in analog mode. Violating this rule may lead to higher power consumption.

12.7.2 Port B digital function specification

Sym	description	min	typ	max	unit	Comments
V _{INH}	Input high voltage	0.7*VBAT		VBAT	V	VBAT≥2.4V
V _{INL}	Input low voltage	VSS		0.2*VBAT	V	VBAT≥2.4V
V _{OH}	Output high voltage	VBAT-0.4		VBAT	V	VBAT=1.2V, I _{OH} =0.3mA VBAT=2.4V, I _{OH} =5.0mA VBAT=4.5V, I _{OH} =8.0mA
V _{OL}	Output low voltage	VSS		VSS+0.4	V	VBAT=1.2V, I _{OL} =0.3mA VBAT=2.4V, I _{OL} =12.0mA VBAT=4.5V, I _{OL} =15.0mA
R _{PU}	Pull-up resistance	20	50	80	kΩ	
C _{in}	Input capacitance		3.5		pF	Note 1

Note 1: this value is indicative only since it depends on the package.

13 Port C

13.1	Features	13-2
13.2	Overview	13-2
13.3	Port C (PC) Operation	13-2
13.4	Register map	13-2
13.5	Port C electrical specification	13-3

Not Recommended for
New Designs

13.1 Features

- Input / output port, 8 bits wide
- Each bit can be set individually for input or output

13.2 Overview

Port C (PC) is a general purpose 8 bit input/output digital port. Figure 13-1 shows its structure.

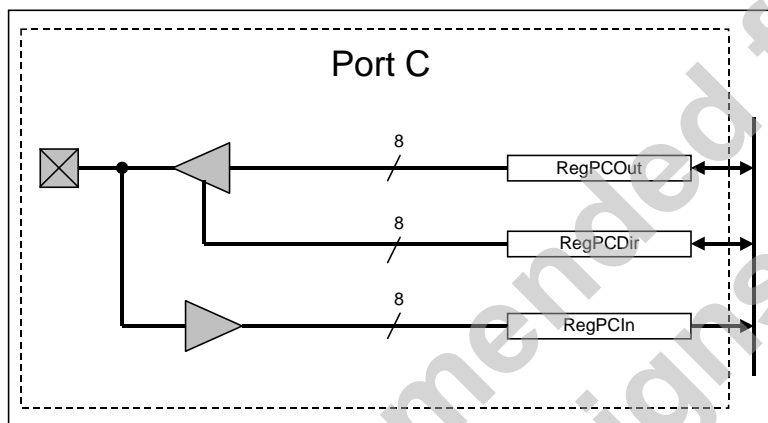

Figure 13-1: structure of Port C

13.3 Port C (PC) Operation

The direction of each bit within Port C (input or output) can be individually set by using the **RegPCDir** register. If **PCDir[x] = 1**, the corresponding Port C pin becomes an output. After reset, Port C is in input mode (**PCDir[x]** are reset to 0).

Output mode:

Data is stored in **RegPCOut** prior to output at Port C.

Input mode:

The status of Port C is available in **RegPCIn** (read only). Reading is always direct - there is no digital debounce function associated with Port C. In case of possible noise on input signals, a software debouncer or an external filter must be realized.

By default after reset, Port C is configured as an input port.

13.4 Register map

There are three registers in the Port C (PC), namely **RegPCIn**, **RegPCOut** and **RegPCDir**. Table 13-1 to Table 13-3 show the mapping of control bits and functionality of these registers.

Pos.	RegPCIn	Rw	Reset	Description
7-0	PCIn	r	-	pad PC input value

Table 13-1. **RegPCIn**

Pos.	RegPCOut	Rw	Reset	Description
7-0	PCOut	r w	0 resetpconf	pad PC output value

Table 13-2. RegPCOut

Pos.	RegPCDir	Rw	Reset	Description
7-0	PCDir	r w	0 resetpconf	pad PC direction (0=input)

Table 13-3. RegPCDir

13.5 Port C electrical specification

Sym	description	min	typ	max	unit	Comments
V _{INH}	Input high voltage	0.7*VBAT		VBAT	V	VBAT≥2.4V
V _{INL}	Input low voltage	VSS		0.2*VBAT	V	VBAT≥2.4V
V _{OH}	Output high voltage	VBAT-0.4		VBAT	V	VBAT=1.2V, I _{OH} =0.3mA VBAT=2.4V, I _{OH} =5.0mA VBAT=4.5V, I _{OH} =8.0mA
V _{OL}	Output low voltage	VSS		VSS+0.4	V	VBAT=1.2V, I _{OL} =0.3mA VBAT=2.4V, I _{OL} =12.0mA VBAT=4.5V, I _{OL} =15.0mA
C _{in}	Input capacitance		3.0		pF	Note 1

Note 1: this value is indicative only since it depends on the package.

Table 13-4. Port C electrical specification

14 UART

14.1	Features	14-2
14.2	Overview	14-2
14.3	Registers map	14-2
14.4	Interrupts map	14-3
14.5	Uart baud rate selection	14-3
14.5.1	Uart on the RC oscillator	14-3
14.5.2	Uart on the crystal oscillator	14-4
14.6	Function description	14-4
14.6.1	Configuration bits	14-4
14.6.2	Transmission	14-5
14.6.3	Reception	14-5
14.7	Interrupt or polling	14-6
14.8	Software hints	14-7

14.1 Features

- Full duplex operation with buffered receiver and transmitter.
- Internal baud rate generator with 12 programmable baud rates (300 - 115200).
- 7 or 8 bits word length.
- Even, odd, or no-parity bit generation and detection
- 1 stop bit
- Error receive detection: Start, Parity, Frame and Overrun
- Receiver echo mode
- 2 interrupts (receive full and transmit empty)
- Enable receive and/or transmit
- Invert pad Rx and/or Tx

14.2 Overview

The UART pins are PB[7], which is used as Rx - receive and PB[6] as Tx - transmit.

14.3 Registers map

pos.	RegUartCmd	rw	Reset	Description
7	SelXtal	rw	0 resetsystem	Select input clock: 0 = RC, 1 = xtal
6	UartEnRx2	rw	0 resetsystem	Enable Uart Reception
5-3	UartRcSel(2:0)	rw	000 resetsystem	RC prescaler selection
2	UartPM	rw	0 resetsystem	Select parity mode: 0 = odd, 1 = even
1	UartPE	rw	0 resetsystem	Enable parity: 1 = with parity, 0 = no parity
0	UartWL	rw	1 resetsystem	Select word length: 1 = 8 bits, 0 = 7 bits

Table 14-1: RegUartCmd

Pos.	RegUartCtrl	rw	reset	Description
7	UartEcho	rw	0 resetsystem	Enable echo mode: 1 = echo Rx->Tx, 0 = no echo
6	UartEnRx1	rw	0 resetsystem	Enable uart reception
5	UartEnTx	rw	0 resetsystem	Enable uart transmission
4	UartXRx	rw	0 resetsystem	Invert pad Rx
3	UartXTx	rw	0 resetsystem	Invert pad Tx
2-0	UartBR(2:0)	rw	101 resetsystem	Select baud rate

Table 14-2: RegUartCtrl

pos.	RegUartTx	rw	reset	Description
7-0	UartTx	rw	00000000 resetsystem	Data to be sent

Table 14-3: RegUartTx

pos.	RegUartTxSta	rw	reset	description
7-2	-	r	000000	Unused
1	UartTxBusy	r	0 resetsystem	Uart busy transmitting
0	UartTxFull	r	0 resetsystem	RegUartTx full Set by writing to RegUartTx Cleared when transferring RegUartTx into internal shift register

Table 14-4: RegUartTxSta

pos.	RegUartRx	rw	reset	description
7-0	UartRx	r	00000000 resetsystem	Received data

Table 14-5: RegUartRx

pos.	RegUartRxSta	rw	Reset	description
7-6	-	r	00	Unused
5	UartRxSErr	r	0 resetsystem	Start error
4	UartRxPErr	r	0 resetsystem	Parity error
3	UartRxFErr	r	0 resetsystem	Frame error
2	UartRxOErr	rc	0 resetsystem	Overrun error Cleared by writing RegUartRxSta
1	UartRxBusy	r	0 resetsystem	Uart busy receiving
0	UartRxFull	r	0 resetsystem	RegUartRx full Cleared by reading RegUartRx

Table 14-6: RegUartRxSta

14.4 Interrupts map

interrupt source	default mapping in the interrupt manager
Irq_uart_Tx	IrqHig(1)
Irq_uart_Rx	IrqHig(0)

Table 14-7: Interrupts map

14.5 Uart baud rate selection

In order to have correct baud rates, the Uart interface has to be fed with a stable and trimmed clock source. The clock source can be the RC oscillator or the crystal oscillator. The precision of the baud rate will depend on the precision of the selected clock source.

14.5.1 Uart on the RC oscillator

To select the RC oscillator for the Uart, the bit **SeIXtal** in **RegUartCmd** has to be 0.

In order to obtain a correct baud rate, the RC oscillator frequency has to be set to one of the frequencies given in the table on the next page. The precision of the obtained baud rate is directly proportional to the frequency deviation with respect to the values in the table.

Frequency selection for correct Uart baud rate with RC oscillator (Hz)
2'457'600
1'843'200
1'228'800
614'400

For each of these frequencies, the baud rate can be selected with the bits **UartBR(2:0)** in **RegUartCtrl** and **UartRcSel(2:0)** in **RegUartCmd** as shown in **Table 14-8**

RC frequency (Hz)	2'457'600	1'228'800	614'400	1'843'200
UartRcSel	010	001	000	000
UartBR	111	38400		115200
	110	19200		57600
	101	9600		28800
	100	Not possible	4800	14400

Table 14-8: Uart baud rate with RC clock

Note: The precision of the baud rate is directly proportional to the frequency deviation of the used clock from the ideal frequency given in the table. In order to increase the precision and stability of the RC oscillator, the DFLL (digital frequency locked loop) can be used with the crystal oscillator as a reference.

14.5.2 Uart on the crystal oscillator

In order to use the crystal oscillator as the clock source for the Uart, the bit **SelXtal** in **RegUartCmd** has to be set. The crystal oscillator has to be enabled by setting the **EnableXtal** bit in **RegSysClock**. The baud rate selection is done using the **UartBR** and **UartRcSel** bits as shown in Table 14-9.

Xtal freq. (Hz)	UartRcSel	UartBR	Baud rate
32768	001	011	2400
		010	1200
		001	600
		000	300

Table 14-9: Uart baud rate with Xtal clock

Due to the odd ratio between the crystal oscillator frequency and the baud rate, the generated baud rate has a systematic error of -2.48%.

14.6 Function description

14.6.1 Configuration bits

The configuration bits of the Uart serial interface can be found in the registers **RegUartCmd** and **RegUartCtrl**.

The bit **SelXtal** is used to select the clock source (see chapter 14.5). The bits **UartSelRc** and **UartBR** select the baud rate (see chapter 14.5).

The bits **UartEnTx** is used to enable or disable the transmission.

The bits **UartEnRx1** and **UartEnRx2** are used to enable or disable the reception. When one is set to 1, the reception is enabled.

The word length (7 or 8 data bits) can be chosen with **UartWL**. A parity bit is added during transmission or checked during reception if **UartPE** is set. The parity mode (odd or even) can be chosen with **UartPM**.

Setting the bits **UartXRx** and **UartXTx** inverts the Rx respectively Tx signals.

The bit **UartEcho** is used to send the received data automatically back. The transmission function becomes then: Tx = Rx XOR **UartXTx**.

14.6.2 Transmission

In order to send data, the transmitter has to be enabled by setting the bit **UartEnTx**. Data to be sent has to be written to the register **RegUartTx**. The bit **UartTxFull** in **RegUartTxSta** then goes to 1, indicating to the transmitter that a new word is available. As soon as the transmitter has finished sending the previous word, it then loads the contents of the register **RegUartTx** to an internal shift register and clears the **UartTxFull** bit. An interrupt is generated on Irq_uart_Tx at the falling edge of the **UartTxFull** bit. The bit **UartTxBusy** in **RegUartTxSta** shows that the transmitter is busy transmitting a word.

A timing diagram is shown in Figure 14-1. Data are first sent LSB.

New data should be written to the register **RegUartTx** only while **UartTxFull** is 0, otherwise data will be lost.

Asynchronous Transmission

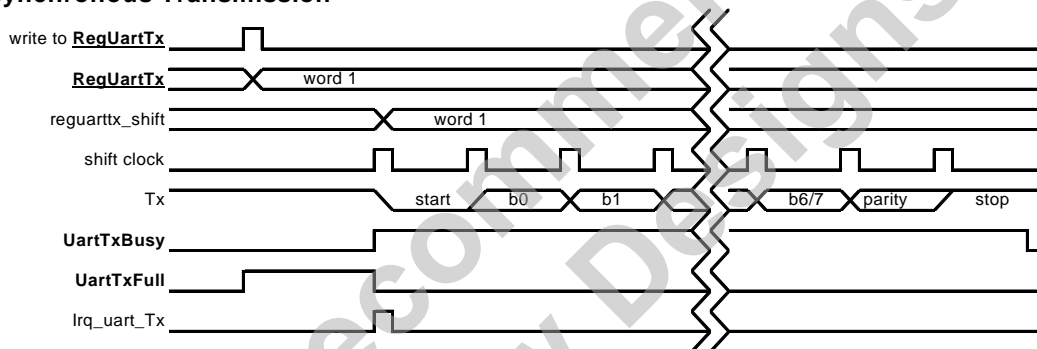

Asynchronous Transmission (back to back)

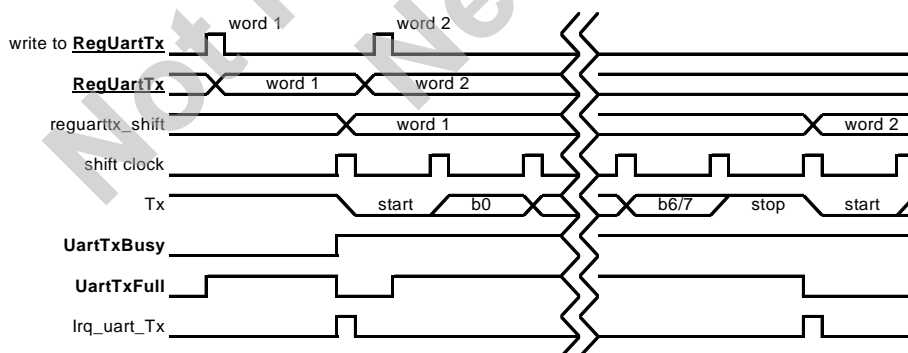

Figure 14-1. Uart transmission timing diagram.

14.6.3 Reception

On detection of the start bit, the **UartRxBusy** bit is set. On detection of the stop bit, the received data are transferred from the internal shift register to the register **RegUartRx**. At the same time, the **UartRxFull** bit is set

and an interrupt is generated on Irq_uart_Rx. This indicates that new data is available in **RegUartRx**. The timing diagram is shown in Figure 14-2.

The **UartRxFull** bit is cleared when **RegUartRx** is read. If the register was not read before the receiver transfers a new word to it, the bit **UartRxOErr** (overflow error) is set and the previous contents of the register is lost. **UartRxOErr** is cleared by writing any data to **RegUartRxSta**.

The bit **UartRxSErr** is set if a start error has been detected. The bit is updated at data transfer to **RegUartRx**.

The bit **UartRxPErr** is set if a parity error has been detected, i.e. the received parity bit is not equal to the calculated parity of the received data. The bit is updated at data transfer to **RegUartRx**.

The bit **UartRxFErr** in **RegUartRxSta** shows that a frame error has been detected. No stop bit has been detected.

Asynchronous Reception

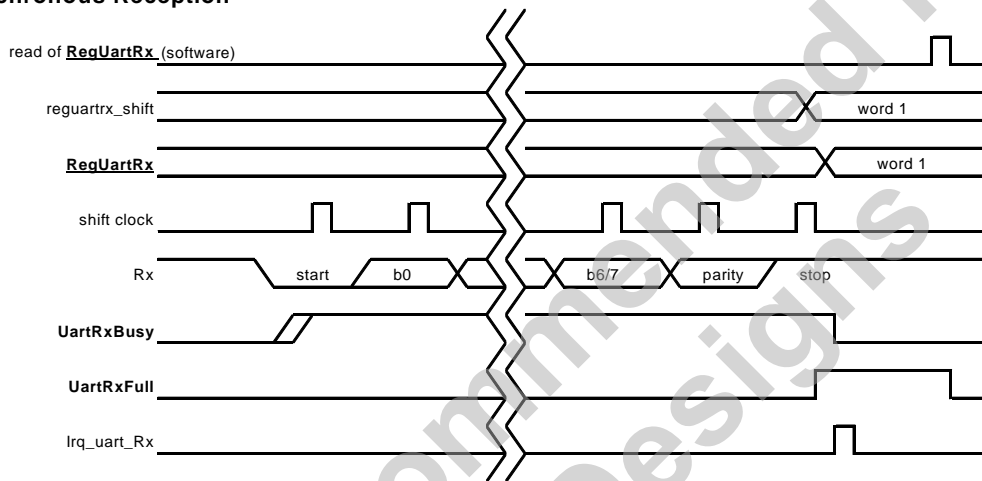

Figure 14-2. Uart reception timing diagram.

14.7 Interrupt or polling

The transmission and reception software can be driven by interruption or by polling the status bits.

Interrupt driven reception: each time an Irq_uart_Rx interrupt is generated, a new word is available in **RegUartRx**. The register has to be read before a new word is received.

Interrupt driven transmission: each time the contents of **RegUartTx** is transferred to the transmission shift register, an Irq_uart_Tx interrupt is generated. A new word can then be written to **RegUartTx**.

Reception driven by polling: the **UartRxFull** bit is to be read and checked. When it is 1, the **RegUartRx** register contains new data and has to be read before a new word is received.

Transmission driven by polling: the **UartTxFull** bit is to read and checked. When it is 0, the **RegUartTx** register is empty and a new word can be written to it.

14.8 Software hints

Example of program for a transmission with polling:

1. The **RegUartCmd** register and the **RegUartCtrl** register are initialized (for example: 8 bit word length, odd parity, 9600 baud, enable Uart transmission).
2. Write a byte to **RegUartTx**.
3. Wait until the **UartTxFull** bit in **RegUartTxSta** register equals 0.
4. Jump to 2 to write the next byte if the message is not finished.
5. End of transmission.

Example of program for a transmission with interrupt:

1. The **RegUartCmd** register and the **RegUartCtrl** register are initialized (for example: 8 bit word length, odd parity, 9600 baud, enable Uart transmission).
2. Write a byte to **RegUartTx**.
3. After an interrupt and if the message is not finished, jump to 2
4. End of transmission.

Example of program for a reception with polling:

1. The **RegUartCmd** register and the **RegUartCtrl** register are initialized (for example: 8 bit word length, odd parity, 9600 baud, enable Uart reception).
2. Wait until the **UartRxFull** bit in the **RegUartRxSta** register equals 1.
3. Read the **RegUartRxSta** and check if there is no error.
4. Read data in **RegUartRx**.
5. If data is not equal to End-Of-Line, then jump to 2.
6. End of reception.

Example of program for a reception with interrupt:

1. The **RegUartCmd** register and the **RegUartCtrl** register are initialized (for example: 8 bit word length, odd parity, 9600 baud, enable Uart reception).
2. When there is an interrupt, jump to 3
3. Read **RegUartRxSta** and check if there is no error.
4. Read data in **RegUartRx**.
5. If data is not equal to End-Of-Line, then jump to 2.
6. End of reception.

15 USRT

15.1	Features	15-2
15.2	Overview	15-2
15.3	Register map	15-2
15.4	Interrupts map	15-4
15.5	Conditional edge detection 1	15-4
15.6	Conditional edge detection 2	15-4
15.7	Interrupts or polling	15-5
15.8	Function description	15-5

Not Recommended for
New Designs

15.1 Features

The USRT implements a hardware support for software implemented serial protocols:

- Control of two external lines S0 and S1 (read/write).
- Conditional edge detection generates interrupts.
- S0 rising edge detection.
- S1 value is stored on S0 rising edge.
- S0 signal can be forced to 0 after a falling edge on S0 for clock stretching in the low state.
- S0 signal can be stretched in the low state after a falling edge on S0 and after a S1 conditional detection.

15.2 Overview

The USRT block supports software universal synchronous receiver and transmitter mode interfaces.

External lines S0 and S1 respectively correspond to clock line and data line. S0 is mapped to PB[4] and S1 to PB[5] when the USRT block is enabled. It is independent from **RegPBdir** (Port B can be input or output). When USRT is enabled, the configurations in port B for PB[4] and PB[5] are overwritten by the USRT configuration. Internal pull-ups can be used by setting the **PBPullup[5:4]** bits.

Conditional edge detections are provided.

RegUsrtS1 can be used to read the S1 data line from PB[5] in receive mode or to drive the output S1 line PB[5] by writing it when in transmit mode. It is advised to read S1 data when in receive mode from the **RegUsrtBufferS1** register, which is the S1 value sampled on a rising edge of S0.

15.3 Register map

Block configuration registers:

pos.	RegUsrtS1	rw	reset	function
7-1	-	r	0000000	Unused
0	UsrtS1	rw	1 resetsystem	Write: data S1 written to pad PB[5]), Read: value on PB[5] (not UsrtS1 value).

Table 15-1: **RegUsrtS1**

pos.	RegUsrtS0	rw	Reset	function
7-1	-	r	0000000	Unused
0	UsrtS0	rw	1 resetsystem	Write: clock S0 written to pad PB[4], Read: value on PB[4] (not UsrtS0 value).

Table 15-2: **RegUsrtS0**

The values that are read in the registers **RegUsrtS1** and **RegUsrtS0** are not necessarily the same as the values that were written in the register. The read value is read back on the circuit pins, not in the registers. Since the outputs are open drain, a value different from the register value may be forced by an external circuit on the circuit pins.

pos.	RegUsrtCtrl	rw	reset	function
7-4	-	r	"0000"	Unused
3	UsrtWaitS0	r	0 resetsystem	Clock stretching flag (0=no stretching), cleared by writing RegUsrtBufferS1
2	UsrtEnWaitCond1	rw	0 resetsystem	Enable stretching on UsrtCond1 detection (0=disable)
1	UsrtEnWaitS0	rw	0 resetsystem	Enable stretching operation (0=disable)
0	UsrtEnable	rw	0 resetsystem	Enable USRT operation (0=disable)

 Table 15-3: **RegUsrtCtrl**

pos.	RegUsrtCond1	rw	reset	function
7-1	-	r	0000000	Unused
0	UsrtCond1	r/c	0 resetsystem	State of condition 1 detection (1 =detected), cleared when written.

 Table 15-4: **RegUsrtCond1**

pos.	RegUsrtCond2	rw	reset	function
7-1	-	r	0000000	Unused
0	UsrtCond2	r/c	0 resetsystem	State of condition 2 detection (1 =detected), cleared when written.

 Table 15-5: **RegUsrtCond2**

pos.	RegUsrtBufferS1	rw	reset	function
7-1	-	r	0000000	Unused
0	UsrtBufferS1	r	x	Value on S1 at last S0 rising edge. Clear RegUsrtEdgeS0 bit in RegUsrtEdgeS0
		w		Clear UsrtWaitS0 bit in RegUsrtCtrl with any value

 Table 15-6: **RegUsrtBufferS1**

pos.	RegUsrtEdgeS0	rw	reset	function
7-1	-	r	0000000	Unused
0	UsrtEdgeS0	r	0 resetsystem	State of rising edge detection on S0 (1=detected). Cleared by reading RegUsrtBufferS1

Table 15-7: RegUsrtEdgeS0

15.4 Interrupts map

interrupt source	default mapping in the interrupt manager
Irq_cond1	RegIrqMid(7)
Irq_cond2	RegIrqMid(6)

Table 15-8: Interrupts map

15.5 Conditional edge detection 1

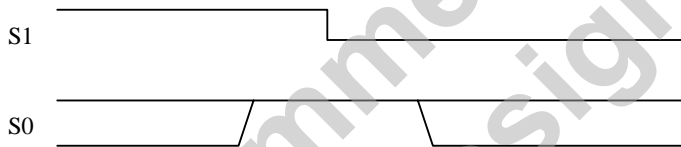

Figure 15-1: Condition 1

Condition 1 is satisfied when S0=1 at the falling edge of S1. The bit **UsrtCond1** in **RegUsrtCond1** is set when the condition 1 is detected and the USRT interface is enabled (**UsrtEnable=1**). Condition 1 is asserted for both modes (receiver and transmitter). The **UsrtCond1** bit is read only and is cleared by all reset conditions and by writing any data to its address.

Condition 1 occurrence also generates an interrupt on Irq_cond1.

15.6 Conditional edge detection 2

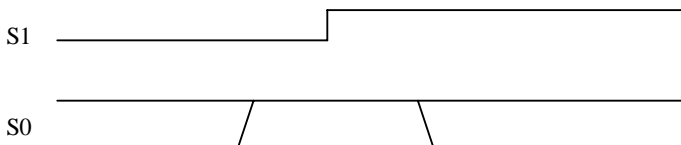

Figure 15-2: Condition 2

Condition 2 is satisfied when $S0=1$ at the rising edge of $S1$. The bit **UsrtCond2** in **RegUsrtCond2** is set when the condition 2 is detected and the USRT interface is enabled. Condition 2 is asserted for both modes (receiver and transmitter). The **UsrtCond2** bit is read only and is cleared by all reset conditions and by writing any data to its address.

Condition 2 occurrence also generates an interrupt on `Irq_cond2`.

15.7 Interrupts or polling

In receive mode, there are two possibilities for detecting condition 1 or 2: the detection of the condition can generate an interrupt or the registers can be polled (reading and checking the **RegUsrtCond1** and **RegUsrtCond2** registers for the status of USRT communication).

15.8 Function description

The bit **UsrtEnable** in **RegUsrtCtrl** is used to enable the USRT interface and controls the PB[4] and PB[5] pins. This bit puts these two port B lines in the open drain configuration requested to use the USRT interface.

If no external pull-ups are added on PB[4] and PB[5], the user can activate internal pull-ups by setting **PBPullup[4]** and **PBPullup[5]** in **RegPBPullup**.

The bits **UsrtEnWaitS0**, **UsrtEnWaitCond1**, **UsrtWaitS0** in **RegUsrtCtrl** are used for transmitter/receiver control of USRT interface.

Figure 15-3 shows the unconditional clock stretching function which is enabled by setting **UsrtEnWaitS0**.

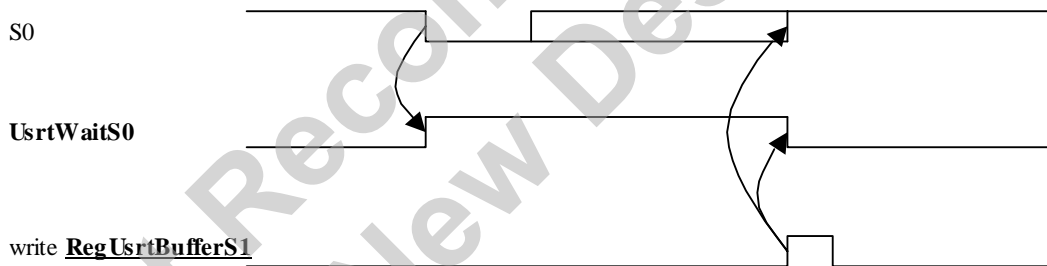

Figure 15-3: S0 Stretching ($UsrtEnWaitS0=1$)

When **UsrtEnWaitS0** is 1, the $S0$ line will be maintained at 0 after its falling edge (clock stretching). **UsrtWaitS0** is then set to 1, indicating that the $S0$ line is forced low. One can release $S0$ by writing to the **RegUsrtBufferS1** register.

The same can be done in combination with condition 1 detection by setting the **UsrtEnWaitCond1** bit. Figure 15-4 shows the conditional clock stretching function which is enabled by setting **UsrtEnWaitCond1**.

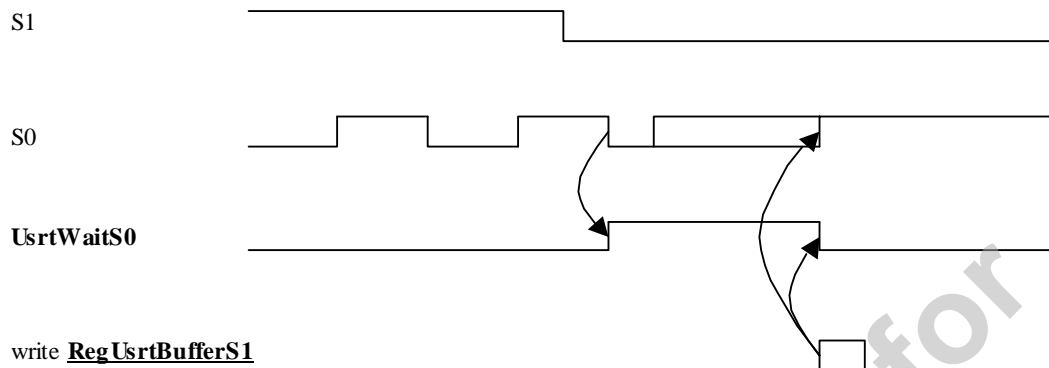

Figure 15-4: Conditional stretching (UsrtEnWaitCond1=1)

When **UsrtEnWaitCond1** is 1, the S0 signal will be stretched in its low state after its falling edge if the condition 1 has been detected before (**UsrtCond1=1**). **UsrtWaitS0** is then set to 1, indicating that the S0 line is forced low. One can release S0 by writing to the **RegUsrtBufferS1** register.

Figure 15-5 shows the sampling function implemented by the **UsrtBufferS1** bit. The bit **UsrtBufferS1** in **RegUsrtBufferS1** is the value of S1 sampled on PB[4] at the last rising edge of S0. The bit **UsrtEdgeS0** in **RegUsrtEdgeS0** is set to one on the same S0 rising edge and is cleared by a read operation of the **RegUsrtBufferS1** register. The bit therefore indicates that a new value is present in the **RegUsrtBufferS1** which has not yet been read.

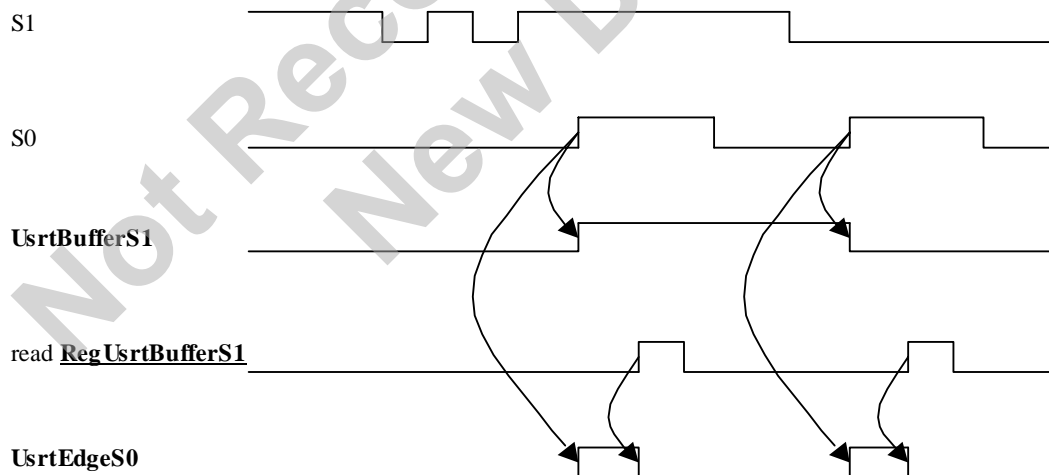

Figure 15-5: S1 sampling

16. Acquisition Chain

16.1	ZoomingADC™ Features	16-2
16.2	Overview	16-2
16.3	Register map	16-2
16.4	ZoomingADC™ Description	16-4
16.4.1	Acquisition Chain	16-4
16.4.2	Peripheral Registers.....	16-6
16.4.3	Continuous-Time vs. On-Request	16-8
16.5	Input Multiplexers	16-9
16.6	Programmable Gain Amplifiers.....	16-10
16.6.1	PGA & ADC Enabling.....	16-12
16.6.2	PGA1	16-12
16.6.3	PGA2	16-12
16.6.4	PGA3	16-12
16.7	ADC Characteristics	16-13
16.7.1	Conversion Sequence	16-13
16.7.2	Sampling Frequency	16-14
16.7.3	Over-Sampling Ratio.....	16-14
16.7.4	Elementary Conversions	16-14
16.7.5	Resolution	16-15
16.7.6	Conversion Time & Throughput	16-16
16.7.7	Output Code Format	16-16
16.7.8	Power Saving Modes	16-18
16.8	Specifications and Measured Curves.....	16-18
16.8.1	Default Settings.....	16-19
16.8.2	Specifications.....	16-20
16.8.3	Linearity	16-21
16.8.3.1	Integral non-linearity.....	16-21
16.8.3.2	Differential non-linearity	16-25
16.8.4	Noise.....	16-26
16.8.5	Gain Error and Offset Error	16-27
16.8.6	Power Consumption.....	16-28
16.8.7	Power Supply Rejection Ratio.....	16-30
16.9	Application Hints.....	16-31
16.9.1	Input Impedance	16-31
16.9.2	PGA Settling or Input Channel Modifications.....	16-31
16.9.3	PGA Gain & Offset, Linearity and Noise.....	16-31
16.9.4	Frequency Response	16-32
16.9.5	Power Reduction.....	16-33

16.1 ZoomingADC™ Features

The ZoomingADC™ is a complete and versatile low-power analog front-end interface typically intended for sensing applications. The key features of the ZoomingADC™ are:

Programmable 6 to 16-bit dynamic range oversampled ADC

- Flexible gain programming between 0.5 and 1000
- Flexible and large range offset compensation
- 4-channel differential or 8-channel single-ended input multiplexer
- 2-channel differential reference inputs
- Power saving modes
- Direct interfacing to CoolRisc™ microcontroller

16.2 Overview

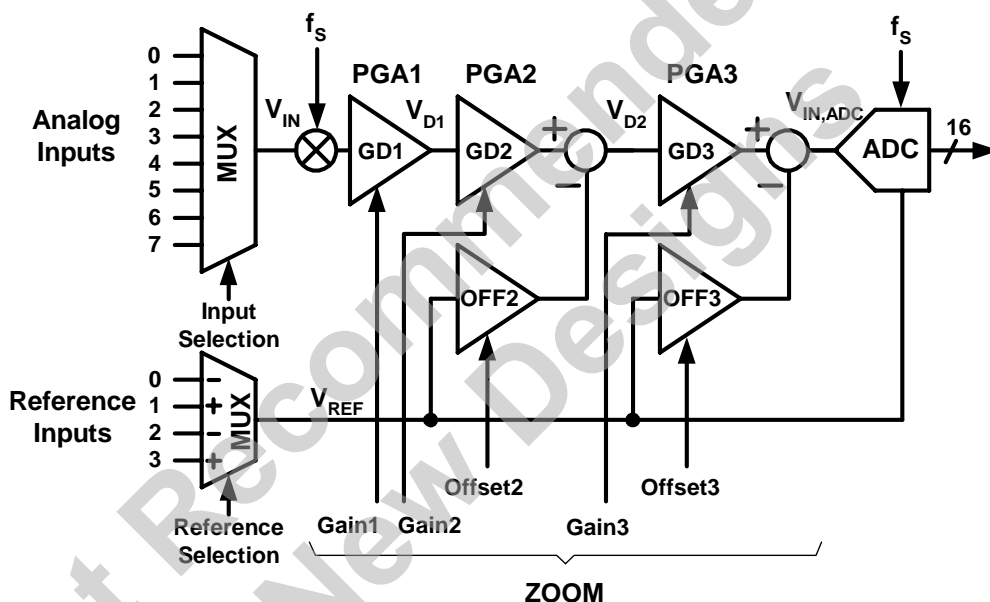

Figure 16-1. ZoomingADC™ general functional block diagram

The total acquisition chain consists of an input multiplexer, 3 programmable gain amplifier stages and an oversampled A/D converter. The reference voltage can be selected on two different channels. Two offset compensation amplifiers allow for a wide offset compensation range. The programmable gain and offset allow one to zoom in on a small portion of the reference voltage defined input range.

16.3 Register map

There are eight registers in the acquisition chain (AC), namely [RegAcOutLsb](#), [RegAcOutMsb](#), [RegAcCfg0](#), [RegAcCfg1](#), [RegAcCfg2](#), [RegAcCfg3](#), [RegAcCfg4](#) and [RegAcCfg5](#). Table 16-2 to Table 16-9 show the mapping of control bits and functionality of these registers while Table 16-1 gives an overview of these eight.

The register map only gives a short description of the different configuration bits. More detailed information is found in subsequent sections.

register name
RegAcOutLsb
RegAcOutMsb
RegAcCfg0
RegAcCfg1
RegAcCfg2
RegAcCfg3
RegAcCfg4
RegAcCfg5

Table 16-1: AC registers

pos.	RegAcOutLsb	rw	reset	description
7:0	Out[7:0]	r	00000000 resetsystem	LSB of the output code

Table 16-2: RegAcOutLsb

pos.	RegAcOutMsb	rw	reset	description
7:0	Out[15:8]	r	00000000 resetsystem	MSB of the output code

Table 16-3: RegAcOutMsb

pos.	RegAcCfg0	rw	reset	description
7	Start	w r0	0 resetsystem	starts a conversion
6:5	SET_NELCONV[1:0]	r w	01 resetsystem	sets the number of elementary conversions
4:2	SET_OSR[2:0]	r w	010 resetsystem	sets the oversampling rate of an elementary conversion
1	CONT	r w	0 resetsystem	continuous conversion mode
0	reserved	r w	0 resetsystem	

Table 16-4: RegAcCfg0

pos.	RegAcCfg1	rw	reset	description
7:6	IB_AMP_ADC[1:0]	r w	11 resetsystem	Bias current selection of the ADC converter
5:4	IB_AMP_PGA[1:0]	r w	11 resetsystem	Bias current selection of the PGA stages
3:0	ENABLE[3:0]	r w	0000 resetsystem	Enables the different PGA stages and the ADC

Table 16-5: RegAcCfg1

pos.	RegAcCfg2	rw	reset	description
7:6	FIN[1:0]	r w	00 resetsystem	Sampling frequency selection
5:4	PGA2_GAIN[1:0]	r w	00 resetsystem	PGA2 stage gain selection
3:0	PGA2_OFFSET[3:0]	r w	0000 resetsystem	PGA2 stage offset selection

Table 16-6: RegAcCfg2

pos.	RegAcCfg3	rw	reset	description
7	PGA1_GAIN	r w	0 resetsystem	PGA1 stage gain selection
6:0	PGA3_GAIN[6:0]	r w	0000000 resetsystem	PGA3 stage gain selection

Table 16-7: RegAcCfg3

pos.	RegAcCfg4	rw	reset	description
7	reserved	r	0	Unused
6:0	PGA3_OFFSET[6:0]	r w	0000000 resetsystem	PGA3 stage offset selection

Table 16-8: RegAcCfg4

pos.	RegAcCfg5	rw	reset	description
7	BUSY	r	0 resetsystem	Activity flag
6	DEF	w r0	0	Selects default configuration
5:1	AMUX[4:0]	r w	00000 resetsystem	Input channel configuration selector
0	VMUX	r w	0 resetsystem	Reference channel selector

Table 16-9: RegAcCfg5

16.4 ZoomingADC™ Description

Figure 16-2 gives a more detailed description of the acquisition chain.

16.4.1 Acquisition Chain

Figure 16-1 shows the general block diagram of the acquisition chain (AC). A control block (not shown in Figure 16-1) manages all communications with the CoolRisc™ microcontroller.

Analog inputs can be selected among eight input channels, while reference input is selected between two differential channels.

The core of the zooming section is made of three differential programmable amplifiers (PGA). After selection of a combination of input and reference signals V_{IN} and V_{REF} , the input voltage is modulated and amplified through stages 1 to 3. Fine gain programming up to 1'000V/V is possible. In addition, the last two stages provide programmable offset. Each amplifier can be bypassed if needed.

The output of the PGA stages is directly fed to the analog-to-digital converter (ADC), which converts the signal $V_{IN,ADC}$ into digital.

Like most ADCs intended for instrumentation or sensing applications, the ZoomingADC™ is an over-sampled converter (See Note¹). The ADC is a so-called incremental converter, with bipolar operation (the ADC accepts both positive and negative input voltages). In first approximation, the ADC output result relative to full-scale (FS) delivers the quantity:

¹ Note: Over-sampled converters are operated with a sampling frequency f_s much higher than the input signal's Nyquist rate (typically f_s is 20-1'000 times the input signal bandwidth). The sampling frequency to throughput ratio is large (typically 10-500). These converters include digital decimation filtering. They are mainly used for high resolution, and/or low-to-medium speed applications.

$$\frac{OUT_{ADC}}{FS/2} \cong \frac{V_{IN,ADC}}{V_{REF}/2} \tag{Eq. 1}$$

in two's complement (see Sections 16.4 and 16.7 for details). The output code OUT_{ADC} is $-FS/2$ to $+FS/2$ for $V_{IN,ADC} \cong -V_{REF}/2$ to $+V_{REF}/2$ respectively. As will be shown in section 16.6, $V_{IN,ADC}$ is related to input voltage V_{IN} by the relationship:

$$V_{IN,ADC} = GD_{TOT} \cdot V_{IN} - GDoff_{TOT} \cdot V_{REF} \tag{Eq. 2}$$

where GD_{TOT} is the total PGA gain, and $GDoff_{TOT}$ is the total PGA offset.

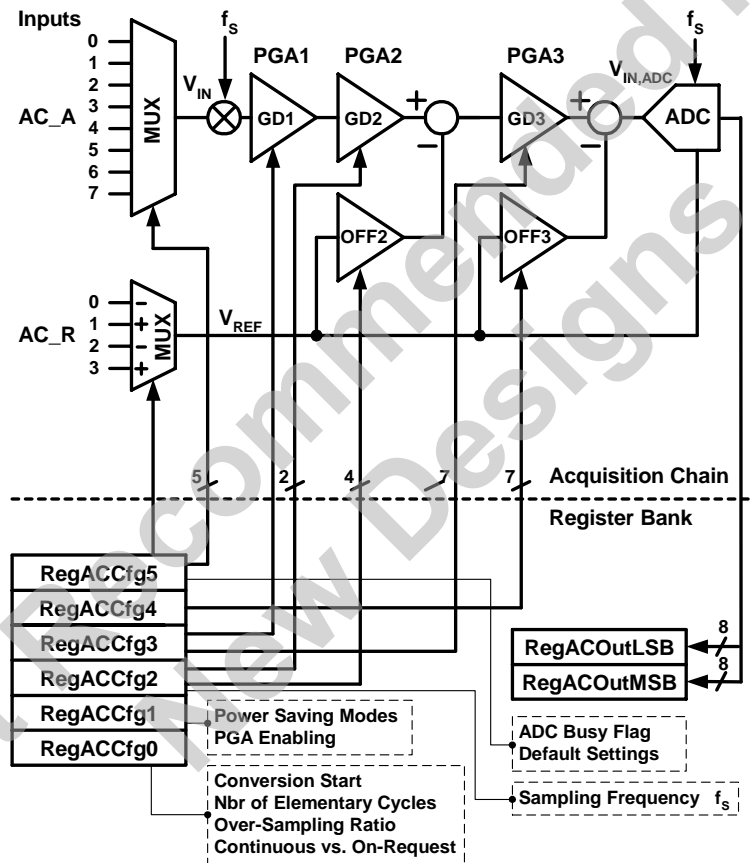

Figure 16-2. ZoomingADC™ detailed functional block diagram

16.4.2 Peripheral Registers

Figure 16-2 shows a detailed functional diagram of the ZoomingADC™.

In table 16-10 the configuration of the peripheral registers is detailed. The system has a bank of eight 8-bit registers: six registers are used to configure the acquisition chain (RegAcCfg0 to 5), and two registers are used to store the output code of the analog-to-digital conversion (RegAcOutMsb & Lsb). The register coding of the ADC parameters and performance characteristics are detailed in Section 16.7.

Table 16-10. Peripheral registers to configure the acquisition chain (AC) and to store the analog-to-digital conversion (ADC) result

Register Name	Bit Position							
	7	6	5	4	3	2	1	0
RegAcOutLsb	OUT [7:0]							
RegAcOutMsb	OUT [15:8]							
RegAcCfg0	START	SET_NELC [1:0]		SET_OSR [2:0]			CONT	TEST
Default values:	0	01		010			0	0
RegAcCfg1	IB_AMP_ADC [1:0]		IB_AMP_PGA [1:0]		ENABLE [3:0]			
Default values:	11		11		0001			
RegAcCfg2	FIN [1:0]		PGA2_GAIN [1:0]		PGA2_OFFSET [3:0]			
Default values:	00		00		0000			
RegAcCfg3	PGA1_G	PGA3_GAIN [6:0]						
Default values:	0	0000000						
RegAcCfg4	PGA3_OFFSET [6:0]							
Default values:	0000000							
RegAcCfg5	BUSY	DEF	AMUX [4:0]				VMUX	
Default values:	0	0	00000				0	

With:

- OUT: (r) digital output code of the analog-to-digital converter. (MSB = OUT [15])
- START: (w) setting this bit triggers a single conversion (after the current one is finished). This bit always reads back 0.
- SET_NELC: (rw) sets the number of elementary conversions to $2^{\text{SET_NELC}[1:0]}$. To compensate for offsets, the input signal is chopped between elementary conversions (1,2,4,8).
- SET_OSR: (rw) sets the over-sampling rate (OSR) of an elementary conversion to $2^{(3+\text{SET_OSR}[2:0])}$. OSR = 8, 16, 32, ..., 512, 1024.
- CONT: (rw) setting this bit starts a conversion. A new conversion will automatically begin as long as the bit remains at 1.
- TEST: bit only used for test purposes. In normal mode, this bit is forced to 0 and cannot be overwritten.
- IB_AMP_ADC: (rw) sets the bias current in the ADC to $0.25 \cdot (1 + \text{IB_AMP_ADC}[1:0])$ of the normal operation current (25, 50, 75 or 100% of nominal current). To be used for low-power, low-speed operation.
- IB_AMP_PGA: (rw) sets the bias current in the PGAs to $0.25 \cdot (1 + \text{IB_AMP_PGA}[1:0])$ of the normal operation current (25, 50, 75 or 100% of nominal current). To be used for low-power, low-speed operation.
- ENABLE: (rw) enables the ADC modulator (bit 0) and the different stages of the PGAs (PGA_i by bit i=1,2,3). PGA stages that are disabled are bypassed.
- FIN: (rw) These bits set the sampling frequency of the acquisition chain. Expressed as a fraction of the oscillator frequency, the sampling frequency is given as: 00 → 1/4 f_{RC} , 01 → 1/8 f_{RC} , 10 → 1/32 f_{RC} , 11 → ~8kHz.
- PGA1_GAIN: (rw) sets the gain of the first stage: 0 → 1, 1 → 10.
- PGA2_GAIN: (rw) sets the gain of the second stage: 00 → 1, 01 → 2, 10 → 5, 11 → 10.
- PGA3_GAIN: (rw) sets the gain of the third stage to $\text{PGA3_GAIN}[6:0] \cdot 1/12$.
- PGA2_OFFSET: (rw) sets the offset of the second stage between -1 and +1, with increments of 0.2. The MSB gives the sign (0 → positive, 1 → negative); amplitude is coded with the bits $\text{PGA2_OFFSET}[5:0]$.
- PGA3_OFFSET: (rw) sets the offset of the third stage between -5.25 and +5.25, with increments of 1/12. The MSB gives the sign (0 → positive, 1 → negative); amplitude is coded with the bits $\text{PGA3_OFFSET}[5:0]$.

- **BUSY:** (r) set to 1 if a conversion is running. Note that the flag is set at the effective start of the conversion. Since the ADC is generally synchronized on a lower frequency clock than the CPU, there might be a small delay (max. 1 cycle of the ADC sampling frequency) between the writing of the START or CONT bits and the appearance of BUSY flag.
- **DEF:** (w) sets all values to their defaults (PGA disabled, max speed, nominal modulator bias current, 2 elementary conversions, over-sampling rate of 32) and starts a new conversion without waiting the end of the preceding one.
- **AMUX(4:0):** (rw) **AMUX[4]** sets the mode (0 → 4 differential inputs, 1 → 7 inputs with $A(0)$ = common reference) **AMUX(3)** sets the sign (0 → straight, 1 → cross) **AMUX[2:0]** sets the channel.
- **VMUX:** (rw) sets the differential reference channel (0 → $R(1)$ and $R(0)$, 1 → $R(3)$ and $R(2)$).
(r = read; w = write; rw = read & write)

Not Recommended for
New Designs

16.4.3 Continuous-Time vs. On-Request

The ADC can be operated in two distinct modes: "continuous-time" and "on-request" modes (selected using the bit **CONT**).

In "continuous-time" mode, the input signal is repeatedly converted into digital. After a conversion is finished, a new one is automatically initiated. The new value is then written in the result register, and the corresponding internal trigger pulse is generated. This operation is sketched in Figure 16-3. The conversion time in this case is defined as T_{CONV} .

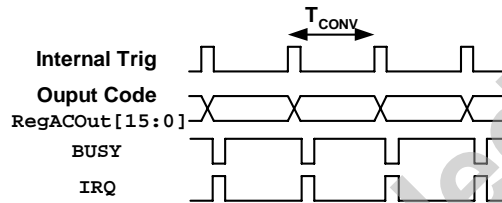

Figure 16-3. ADC "continuous-time" operation

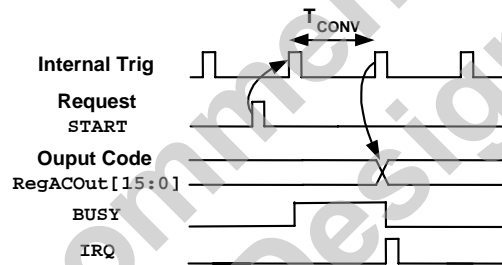

Figure 16-4. ADC "on-request" operation

In the "on-request" mode, the internal behaviour of the converter is the same as in the "continuous-time" mode, but the conversion is initiated on user request (with the **START** bit). As shown in Figure 16-4, the conversion time is also T_{CONV} . Note that the flag is set at the effective start of the conversion. Since the ADC is generally synchronized on a lower frequency clock than the CPU, there might be a small delay (max. 1 cycle of the ADC sampling frequency) between the writing of the **START** or **CONT** bits and the appearance of **BUSY** flag.

16.5 Input Multiplexers

The ZoomingADC™ has eight analog inputs $AC_A(0)$ to $AC_A(7)$ and four reference inputs $AC_R(0)$ to $AC_R(3)$. Let us first define the differential input voltage V_{IN} and reference voltage V_{REF} respectively as:

$$V_{IN} = V_{INP} - V_{INN} \quad (V) \quad (Eq. 3)$$

and:

$$V_{REF} = V_{REFP} - V_{REFN} \quad (V) \quad (Eq. 4)$$

As shown in Table 16-11 the inputs can be configured in two ways: either as 4 differential channels ($V_{IN1} = AC_A(1) - AC_A(0), \dots, V_{IN4} = AC_A(7) - AC_A(6)$), or $AC_A(0)$ can be used as a common reference, providing 7 signal paths all referred to $AC_A(0)$. The control word for the analog input selection is $AMUX[4:0]$. Notice that the bit $AMUX[3]$ controls the sign of the input voltage.

$AMUX[4:0]$ (RegAcCfg5[5:1])	V_{INP}	V_{INN}	$AMUX[4:0]$ (RegAcCfg5[5:1])	V_{INP}	V_{INN}
00x00	$AC_A(1)$	$AC_A(0)$	01x00	$AC_A(0)$	$AC_A(1)$
00x01	$AC_A(3)$	$AC_A(2)$	01x01	$AC_A(2)$	$AC_A(3)$
00x10	$AC_A(5)$	$AC_A(4)$	01x10	$AC_A(4)$	$AC_A(5)$
00x11	$AC_A(7)$	$AC_A(6)$	01x11	$AC_A(6)$	$AC_A(7)$
10000	$AC_A(0)$	$AC_A(0)$	11000	$AC_A(0)$	$AC_A(0)$
10001	$AC_A(1)$		11001		$AC_A(1)$
10010	$AC_A(2)$		11010		$AC_A(2)$
10011	$AC_A(3)$		11011		$AC_A(3)$
10100	$AC_A(4)$		11100		$AC_A(4)$
10101	$AC_A(5)$		11101		$AC_A(5)$
10110	$AC_A(6)$		11110		$AC_A(6)$
10111	$AC_A(7)$		11111		$AC_A(7)$

Table 16-11. Analog input selection

Similarly, the reference voltage is chosen among two differential channels ($V_{REF1} = AC_R(1) - AC_R(0)$ or $V_{REF2} = AC_R(3) - AC_R(2)$) as shown in Table 16-12. The selection bit is $VMUX$. The reference inputs V_{REFP} and V_{REFN} (common-mode) can be up to the power supply range.

VMUX (RegAcCfG5 [0])	V _{REFP}	V _{REFN}
0	AC_R(1)	AC_R(0)
1	AC_R(3)	AC_R(2)

Table 16-12. Analog Reference input selection

16.6 Programmable Gain Amplifiers

As seen in Figure 16-1, the zooming function is implemented with three programmable gain amplifiers (PGA). These are:

- PGA1: coarse gain tuning
- PGA2: medium gain and offset tuning
- PGA3: fine gain and offset tuning

All gain and offset settings are realized with ratios of capacitors. The user has control over each PGA activation and gain, as well as the offset of stages 2 and 3. These functions are examined hereafter.

ENABLE [3 : 0]	Block
xxx0	ADC disabled
xxx1	ADC enabled
xx0x	PGA1 disabled
xx1x	PGA1 enabled
x0xx	PGA2 disabled
x1xx	PGA2 enabled
0xxx	PGA3 disabled
1xxx	PGA3 enabled

Table 16-13. ADC & PGA enabling

PGA1_GAIN	PGA1 Gain GD ₁ (V/V)
0	1
1	10

Table 16-14. PGA1 Gain Settings

PGA2_GAIN [1 : 0]	PGA2 Gain GD ₂ (V/V)
00	1
01	2
10	5
11	10

Table 16-15. PGA2 gain settings

PGA2_OFFSET [3:0]	PGA2 Offset $GDoff_2$ (V/V)
0000	0
0001	+0.2
0010	+0.4
0011	+0.6
0100	+0.8
0101	+1
1001	-0.2
1010	-0.4
1011	-0.6
1100	-0.8
1101	-1

Table 16-16. PGA2 offset settings

PGA3_GAIN [6:0]	PGA3 Gain GD_3 (V/V)
0000000	0
0000001	1/12(=0.083)
...	...
0000110	6/12
...	...
0001100	12/12
0010000	16/12
...	...
0100000	32/12
...	...
1000000	64/12
...	...
1111111	127/12(=10.58)

Table 16-17. PGA3 gain settings

PGA3_OFFSET [6:0]	PGA3 Offset $GDoff_3$ (V/V)
0000000	0
0000001	+1/12(=+0.083)
0000010	+2/12
...	...
0010000	+16/12
...	...
0100000	+32/12
...	...
0111111	+63/12(=+5.25)
1000000	0
1000001	-1/12(=-0.083)
1000010	-2/12
...	...
1010000	-16/12
...	...
1100000	-32/12
...	...
1111111	-63/12(=-5.25)

Table 16-18. PGA3 offset settings

16.6.1 PGA & ADC Enabling

Depending on the application objectives, the user may enable or bypass each PGA stage. This is done according to the word **ENABLE** and the coding given in Table 16-13. To reduce power dissipation, the ADC can also be inactivated while idle.

16.6.2 PGA1

The first stage can have a buffer function (unity gain) or provide a gain of 10 (see Table 16-14). The voltage V_{D1} at the output of PGA1 is:

$$V_{D1} = GD_1 \cdot V_{IN} \quad (V) \quad (\text{Eq. 5})$$

where GD_1 is the gain of PGA1 (in V/V) controlled with the bit **PGA1_GAIN**.

16.6.3 PGA2

The second PGA has a finer gain and offset tuning capability, as shown in Table 16-15 and Table 16-16. The voltage V_{D2} at the output of PGA2 is given by:

$$V_{D2} = GD_2 \cdot V_{D1} - GDoff_2 \cdot V_{REF} \quad (V) \quad (\text{Eq. 6})$$

where GD_2 and $GDoff_2$ are respectively the gain and offset of PGA2 (in V/V). These are controlled with the words **PGA2_GAIN[1:0]** and **PGA2_OFFSET[3:0]**.

As shown in equation 6, the offset correction is directly proportional to the reference voltage. All drifts and perturbations on the reference voltage will affect the precision of the offset compensation.

16.6.4 PGA3

The finest gain and offset tuning is performed with the third and last PGA stage, according to the coding of Table 16-17 and Table 16-18. The output of PGA3 is also the input of the ADC. Thus, similarly to PGA2, we find that the voltage entering the ADC is given by:

$$V_{IN,ADC} = GD_3 \cdot V_{D2} - GDoff_3 \cdot V_{REF} \quad (V) \quad (\text{Eq. 7})$$

where GD_3 and $GDoff_3$ are respectively the gain and offset of PGA3 (in V/V). The control words are **PGA3_GAIN[6:0]** and **PGA3_OFFSET[6:0]**. To remain within the signal compliance of the PGA stages, the condition:

$$V_{D1}, V_{D2} < V_{DD} \quad (V) \quad (\text{Eq. 8})$$

must be verified.

As shown in equation 7, the offset correction is directly proportional to the reference voltage. All drifts and perturbations on the reference voltage will affect the precision of the offset compensation.

Finally, combining equations Eq. 5 to Eq. 7 for the three PGA stages, the input voltage $V_{IN,ADC}$ of the ADC is related to V_{IN} by:

$$V_{IN,ADC} = GD_{TOT} \cdot V_{IN} - GDoff_{TOT} \cdot V_{REF} \quad (V) \quad (Eq. 9)$$

where the total PGA gain is defined as:

$$GD_{TOT} = GD_3 \cdot GD_2 \cdot GD_1 \quad (V/V) \quad (Eq. 10)$$

and the total PGA offset is:

$$GDoff_{TOT} = GDoff_3 + GD_3 \cdot GDoff_2 \quad (V/V) \quad (Eq. 11)$$

16.7 ADC Characteristics

The main performance characteristics of the ADC (resolution, conversion time, etc.) are determined by three programmable parameters:

- sampling frequency f_s ,
- over-sampling ratio OSR , and
- number of elementary conversions N_{ELCONV} .

The setting of these parameters and the resulting performances are described hereafter.

16.7.1 Conversion Sequence

A conversion is started each time the bit **START** or the bit **DEF** is set. As depicted in Figure 16-5, a complete analog-to-digital conversion sequence is made of a set of N_{ELCONV} elementary incremental conversions and a final quantization step. Each elementary conversion is made of $(OSR+1)$ sampling periods $T_s=1/f_s$, i.e.:

$$T_{ELCONV} = (OSR + 1) / f_s \quad (s) \quad (Eq. 12)$$

The result is the mean of the elementary conversion results. An important feature is that the elementary conversions are alternatively performed with the offset of the internal amplifiers contributing in one direction and the other to the output code. Thus, converter internal offset is eliminated if at least two elementary sequences are performed (i.e. if $N_{ELCONV} \geq 2$). A few additional clock cycles are also required to initiate and end the conversion properly.

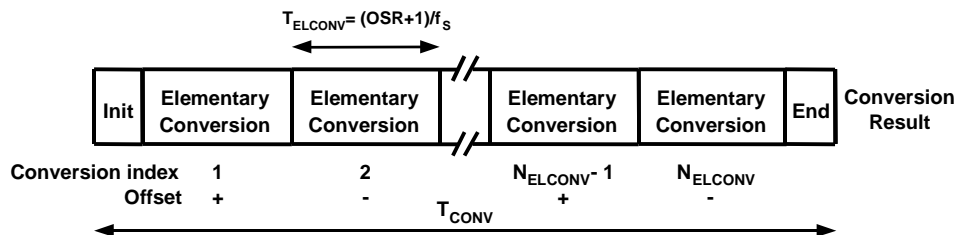

Figure 16-5. Analog-to-digital conversion sequence

16.7.2 Sampling Frequency

The word **FIN**[1:0] is used to select the sampling frequency f_s (Table 16-19). Three sub-multiples of the internal RC-based frequency f_{RCEXT} can be chosen. For **FIN** = "11", sampling frequency is about 8kHz. Additional information on oscillators and their control can be found in the clock block documentation.

FIN [1:0]	Sampling Frequency f_s (Hz)	
	01/05	02
00	$1/4 \cdot f_{RC}$	$1/8 \cdot f_{RCEXT}$
01	$1/8 \cdot f_{RC}$	$1/16 \cdot f_{RCEXT}$
10	$1/32 \cdot f_{RC}$	$1/64 \cdot f_{RCEXT}$
11	~8kHz	~4kHz

Table 16-19. Sampling frequency settings (f_{RC} = RC-based frequency)

16.7.3 Over-Sampling Ratio

The over-sampling ratio (*OSR*) defines the number of integration cycles per elementary conversion. Its value is set with the word **SET_OSR**[2:0] in power of 2 steps (see Table 16-20) given by:

$$OSR = 2^{3+SET_OSR[2:0]} \quad (-) \quad (Eq. 13)$$

SET_OSR [2:0] (RegACCFg0 [4:2])	Over-Sampling Ratio OSR (-)
000	8
001	16
010	32
011	64
100	128
101	256
110	512
111	1024

Table 16-20. Over-sampling ratio settings

16.7.4 Elementary Conversions

As mentioned previously, the whole conversion sequence is made of a set of N_{ELCONV} elementary incremental conversions. This number is set with the word **SET_NELC**[1:0] in power of 2 steps (see Table 16-21) given by:

$$N_{ELCONV} = 2^{SET_NELC[1:0]} \quad (-) \quad (Eq. 14)$$

SET_NELC [1:0] (RegAcCfg0 [6:5])	# of Elementary Conversions N_{ELCONV} (-)
00	1
01	2
10	4
11	8

Table 16-21. Number of elementary conversion settings

As already mentioned, N_{ELCONV} must be equal or greater than 2 to reduce internal amplifier offsets.

16.7.5 Resolution

The theoretical resolution of the ADC, without considering thermal noise, is given by:

$$n = 2 \cdot \log_2(OSR) + \log_2(N_{ELCONV}) \quad (\text{Bits}) \quad (\text{Eq. 15})$$

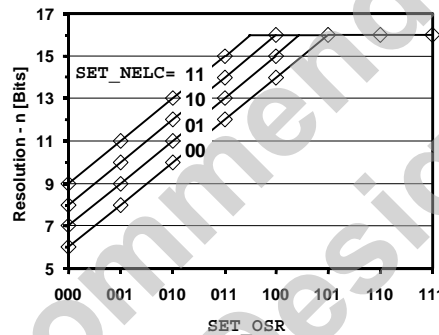

Figure 16-6. Resolution vs. SET_OSR [2:0] and SET_NELC [2:0]

SET_OSR [2:0]	SET_NELC			
	00	01	10	11
000	6	7	8	9
001	8	9	10	11
010	10	11	12	13
011	12	13	14	15
100	14	15	16	16
101	16	16	16	16
110	16	16	16	16
111	16	16	16	16

(shaded area: resolution truncated to 16 bits due to output register size RegAcOut [15:0])

Table 16-22. Resolution vs. SET_OSR [2:0] and SET_NELC [1:0] settings

Using look-up Table 16-22 or the graph plotted in Figure 16-6, resolution can be set between 6 and 16 bits. Notice that, because of 16-bit register use for the ADC output, **practical resolution is limited to 16 bits**, i.e. $n \leq 16$. Even if the resolution is truncated to 16 bit by the output register size, it may make sense to set OSR and N_{ELCONV} to higher values in order to reduce the influence of the thermal noise in the PGA (see section 16.8.4).

16.7.6 Conversion Time & Throughput

As explained using Figure 16-5, conversion time is given by:

$$T_{CONV} = (N_{ELCONV} \cdot (OSR + 1) + 1) / f_s \quad (\text{s}) \quad (\text{Eq. 16})$$

and throughput is then simply $1/T_{CONV}$. For example, consider an over-sampling ratio of 256, 2 elementary conversions, and a sampling frequency of 500kHz ($SET_OSR = "01"$, $SET_NELC = "01"$, $f_{RC} = 2\text{MHz}$, and $FIN = "00"$). In this case, using Table 16-23, the conversion time is 515 sampling periods, or 1.03ms. This corresponds to a throughput of 971Hz in continuous-time mode. The plot of Figure 16-7 illustrates the classic trade-off between resolution and conversion time.

SET_OSR [2:0]	SET_NELC[1:0]			
	00	01	10	11
000	10	19	37	73
001	18	35	69	137
010	34	67	133	265
011	66	131	261	521
100	130	259	517	1033
101	258	515	1029	2057
110	514	1027	2053	4105
111	1026	2051	4101	8201

Table 16-23. Normalized conversion time ($T_{CONV} \cdot f_s$) vs. $SET_OSR [2:0]$ and $SET_NELC [1:0]$ (normalized to sampling period $1/f_s$)

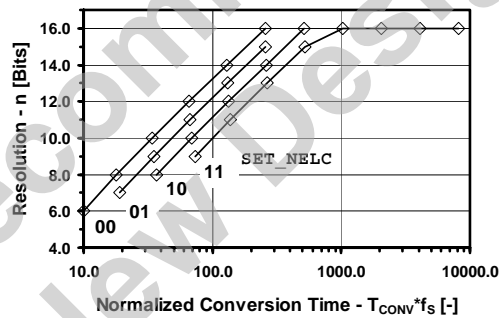

Figure 16-7. Resolution vs. normalized conversion time for different $SET_NELC [1:0]$

16.7.7 Output Code Format

The ADC output code is a 16-bit word in two's complement format (see Table 16-24). For input voltages outside the range, the output code is saturated to the closest full-scale value (i.e. 0x7FFF or 0x8000). For resolutions smaller than 16 bits, the non-significant bits are forced to the values shown in Table 16-25. The output code, expressed in LSBs, corresponds to:

$$OUT_{ADC} = 2^{16} \cdot \frac{V_{IN,ADC}}{V_{REF}} \cdot \frac{OSR + 1}{OSR} \quad (\text{LSB}) \quad (\text{Eq.17})$$

Recalling equation Eq. 9, this can be rewritten as:

$$OUT_{ADC} = 2^{16} \cdot \frac{V_{IN}}{V_{REF}} \cdot \left(GD_{TOT} - GD_{off_{TOT}} \cdot \frac{V_{REF}}{V_{IN}} \right) \cdot \frac{OSR+1}{OSR} \quad (\text{LSB}) \quad (\text{Eq. 18})$$

where, from Eq. 10 and Eq. 11, the total PGA gain and offset are respectively:

$$GD_{TOT} = GD_3 \cdot GD_2 \cdot GD_1 \quad (V/V)$$

and:

$$GD_{off_{TOT}} = GD_{off_3} + GD_3 \cdot GD_{off_2} \quad (V/V)$$

ADC Input Voltage $V_{IN,ADC}$	% of Full Scale (FS)	Output in LSBs	Output Code in Hex
+2.49505V	+0.5-FS	$+2^{15}-1$ =+32'767	7FFF
+2.49497V	...	$+2^{15}-2$ =+32'766	7FFE
...
+76.145μV	...	+1	0001
0V	0	0	0000
-76.145μV	...	-1	FFFF
...
-2.49505V	...	$-2^{15}-1$ =-32'767	8001
-2.49513V	-0.5-FS	-2^{15} =-32'768	8000

Table 16-24. Basic ADC Relationships (example for: $V_{REF} = 5V$, $OSR = 512$, $n = 16$ bits)

SET_OSR [2:0]	SET_NELC = 00	SET_NELC = 01	SET_NELC = 10	SET_NELC = 11
000	1000000000	1000000000	1000000000	1000000000
001	1000000000	1000000000	1000000000	1000000000
010	1000000000	1000000000	1000000000	1000000000
011	1000000000	1000000000	1000000000	1000000000
100	10	1	-	-
101	-	-	-	-
110	-	-	-	-
111	-	-	-	-

Table 16-25. Last forced LSBs in conversion output registers for resolution settings smaller than 16 bits ($n < 16$) (RegAcOutMsb [7:0] & RegAcOutLsb [7:0])

The equivalent LSB size at the input of the PGA chain is:

$$LSB = \frac{1}{2^n} \cdot \frac{V_{REF}}{GD_{TOT}} \cdot \frac{OSR}{OSR+1} \quad (V) \quad (\text{Eq. 19})$$

Notice that the input voltage $V_{IN,ADC}$ of the ADC must satisfy the condition:

$$|V_{IN,ADC}| \leq \frac{1}{2} \cdot (V_{REFP} - V_{REFN}) \cdot \frac{OSR}{OSR+1} \quad (V) \quad (\text{Eq. 20})$$

to remain within the ADC input range.

16.7.8 Power Saving Modes

During low-speed operation, the bias current in the PGAs and ADC can be programmed to save power using the control words **IB_AMP_PGA** [1:0] and **IB_AMP_ADC** [1:0] (see Table 16-26). If the system is idle, the PGAs and ADC can even be disabled, thus, reducing power consumption to its minimum. This can considerably improve battery lifetime.

IB_AMP_ADC [1:0]	IB_AMP_PGA [1:0]	ADC Bias Current	PGA Bias Current	Max. fs [kHz]
00		$1/4 \cdot I_{ADC}$		62.5
01		$1/2 \cdot I_{ADC}$		125
10	x	$3/4 \cdot I_{ADC}$	x	250
11		I_{ADC}		500
	00		$1/4 \cdot I_{PGA}$	62.5
	01		$1/2 \cdot I_{PGA}$	125
x	10	x	$3/4 \cdot I_{PGA}$	250
	11		I_{PGA}	500

Table 16-26. ADC & PGA power saving modes and maximum sampling frequency

16.8 Specifications and Measured Curves

This section presents measurement results for the acquisition chain. A summary table with circuit specifications and measured curves are given.

16.8.1 Default Settings

Unless otherwise specified, the measurement conditions are the following:

- Temperature $T_A = +25^\circ\text{C}$
- $V_{DD} = +5\text{V}$, $\text{GND} = 0\text{V}$, $V_{REF} = +5\text{V}$, $V_{IN} = 0\text{V}$
- RC frequency $f_{RC} = 2\text{MHz}$, sampling frequency $f_S = 500\text{kHz}$
- Offsets $\text{GDOff}_2 = \text{GDOff}_3 = 0$
- Power operation: normal ($\text{IB_AMP_ADC}[1:0] = \text{IB_AMP_PGA}[1:0] = '11'$)
- Resolution: for $n = 12$ bits: $\text{OSR} = 32$ and $N_{ELCONV} = 4$
 for $n = 16$ bits: $\text{OSR} = 512$ and $N_{ELCONV} = 2$

Not Recommended for
New Designs

16.8.2 Specifications

Unless otherwise specified: Temperature $T_A = +25^\circ\text{C}$, $V_{DD} = +5\text{V}$, $\text{GND} = 0\text{V}$, $V_{REF} = +5\text{V}$, $V_{IN} = 0\text{V}$, RC frequency $f_{RC} = 2\text{MHz}$, sampling frequency $f_S = 500\text{kHz}$, Overall PGA gain $GD_{TOT} = 1$, offsets $GDOff_2 = GDOff_3 = 0$. Power operation: normal ($\text{IB_AMP_ADC}[1:0] = \text{IB_AMP_PGA}[1:0] = '11'$). For resolution $n = 12$ bits: $\text{OSR} = 32$ and $N_{ELCONV} = 4$. For resolution $n = 16$ bits: $\text{OSR} = 512$ and $N_{ELCONV} = 2$.

PARAMETER	VALUE			UNITS	COMMENTS/CONDITIONS
	MIN	TYP	MAX		
ANALOG INPUT CHARACTERISTICS					
Differential Input Voltage Ranges $V_{IN} = (V_{INP} - V_{INN})$	-2.42 -24.2 -2.42		+2.42 +24.2 +2.42	V mV mV	Gain = 1, OSR = 32 (Note 1) Gain = 100, OSR = 32 Gain = 1000, OSR = 32
Reference Voltage Range $V_{REF} = (V_{REFP} - V_{REFN})$			V_{DD}	V	
PROGRAMMABLE GAIN AMPLIFIERS (PGA)					
Total PGA Gain, GD_{TOT}	0.5		1000	V/V	
PGA1 Gain, GD_1	1		10	V/V	See Table 16-14
PGA2 Gain, GD_2	1		10	V/V	See Table 16-15
PGA3 Gain, GD_3	0		127/12	V/V	Step=1/12 V/V, See Table 16-17
Gain Setting Precision (each stage)	-3	± 0.5	+3	%	
Gain Temperature Dependence		± 5		ppm/ $^\circ\text{C}$	
Offset					
PGA2 Offset, $GDOff_2$	-1		+1	V/V	
PGA3 Offset, $GDOff_3$	-127/12		+127/12	V/V	Step=0.2 V/V, See Table 16-16
Offset Setting Precision (PGA2 or 3)	-3	± 0.5	+3	%	Step=1/12 V/V, See Table 16-18
Offset Temperature Dependence		± 5		ppm/ $^\circ\text{C}$	(Note 2)
Input Impedance					
PGA1	1500			k Ω	
PGA2, PGA3	150			k Ω	
Output RMS Noise	150			k Ω	PGA1 Gain = 1 (Note 3) PGA1 Gain = 10 (Note 3)
PGA1		205		μV	Maximal gain (Note 3)
PGA2		340		μV	
PGA3		365		μV	(Note 4) (Note 5) (Note 6)
ADC STATIC PERFORMANCE					
Resolution, n	6		16	Bits	(Note 7)
No Missing Codes					(Note 8)
Gain Error		± 0.15		% of FS	(Note 9)
Offset Error		± 1		LSB	n = 16 bits (Note 10)
Integral Non-Linearity, INL					
Resolution n = 16 Bits		± 1.0		LSB	(Note 11)
Differential Non-Linearity, DNL					
Resolution n = 16 Bits		± 0.5		LSB	(Note 12)
Power Supply Rejection Ratio, PSRR		78		dB	$V_{DD} = 5\text{V} \pm 0.3\text{V}$ (Note 13)
		72		dB	$V_{DD} = 3\text{V} \pm 0.3\text{V}$ (Note 13)
DYNAMIC PERFORMANCE					
Sampling Frequency, f_S	3			kHz	
Conversion Time, T_{CONV}		133		cycles/ f_S	n = 12 bits (Note 14)
		1027		cycles/ f_S	n = 16 bits (Note 14)
Throughput Rate (Continuous Mode), $1/T_{CONV}$		3.76		kSps	n = 12 bits, $f_S = 500\text{kHz}$
		0.49		kSps	n = 16 bits, $f_S = 500\text{kHz}$
Nbr of Initialization Cycles, N_{INIT}	0		2	cycles	
Nbr of End Conversion Cycles, N_{END}	0		5	cycles	
PGA Stabilization Delay		OSR		cycles	(Note 15)
DIGITAL OUTPUT					
ADC Output Data Coding					Binary Two's Complement See Table 16-24 and Table 16-25

Specifications (Cont'd)

PARAMETER	VALUE			UNITS	COMMENTS/CONDITIONS
	MIN	TYP	MAX		
POWER SUPPLY					
Voltage Supply Range, V_{DD}	+2.4	+5	+5.5	V	Only Acquisition Chain $V_{DD} = 5V/3V$ $V_{DD} = 5V/3V$ $V_{DD} = 5V/3V$ $V_{DD} = 5V/3V$ $V_{DD} = 5V/3V$ All PGAs & ADC Active $V_{DD} = 5V/3V$ (Note 16) $V_{DD} = 5V/3V$ (Note 17) $V_{DD} = 5V/3V$ (Note 18) $V_{DD} = 5V/3V$ (Note 19)
Analog Quiescent Current					
Consumption, Total (I_o)		720/620		μA	
ADC Only		250/190		μA	
PGA1		165/150		μA	
PGA2		130/120		μA	
PGA3		175/160		μA	
Analog Power Dissipation					
Normal Power Mode		3.6/1.9		mW	
3/4 Power Reduction Mode		2.7/1.4		mW	
1/2 Power Reduction Mode		1.8/0.9		mW	
1/4 Power Reduction Mode		0.9/0.5		mW	
TEMPERATURE					
Specified Range	-40		+85	$^{\circ}C$	
Operating Range	-40		+125	$^{\circ}C$	

Notes:

- (1) Gain defined as overall PGA gain $GD_{TOT} = GD_1 \cdot GD_2 \cdot GD_3$. Maximum input voltage is given by: $V_{IN,MAX} = \pm(V_{REF}/2) \cdot (OSR/OSR+1)$.
- (2) Offset due to tolerance on $GDOFF_2$ or $GDOFF_3$ setting. For small intrinsic offset, use only ADC and PGA1.
- (3) Measured with block connected to inputs through AMUX block. Normalized input sampling frequency for input impedance is $f_S = 512kHz$. This figure must be multiplied by 2 for $f_S = 256kHz$, 4 for $f_S = 128kHz$. Input impedance is proportional to $1/f_S$.
- (4) Figure independent from PGA1 gain and sampling frequency f_S . See model of Figure 16-18(a). See equation Eq. 21 to calculate equivalent input noise.
- (5) Figure independent on PGA2 gain and sampling frequency f_S . See model of Figure 16-18(a). See equation Eq. 21 to calculate equivalent input noise.
- (6) Figure independent on PGA3 gain and sampling frequency f_S . See model of Figure 16-18(a) and equation Eq. 21 to calculate equivalent input noise.
- (7) Resolution is given by $n = 2 \cdot \log_2(OSR) + \log_2(N_{ELCONV})$. OSR can be set between 8 and 1024, in powers of 2. N_{ELCONV} can be set to 1, 2, 4 or 8.
- (8) If a ramp signal is applied to the input, all digital codes appear in the resulting ADC output data.
- (9) Gain error is defined as the amount of deviation between the ideal (theoretical) transfer function and the measured transfer function (with the offset error removed). (See Figure 16-19)
- (10) Offset error is defined as the output code error for a zero volt input (ideally, output code = 0). For ± 1 LSB offset, N_{ELCONV} must be ≥ 2 .
- (11) INL defined as the deviation of the DC transfer curve of each individual code from the best-fit straight line. This specification holds over the full scale.
- (12) DNL is defined as the difference (in LSB) between the ideal (1 LSB) and measured code transitions for successive codes.
- (13) Figures for Gains = 1 to 100. PSRR is defined as the amount of change in the ADC output value as the power supply voltage changes.
- (14) Conversion time is given by: $T_{CONV} = (N_{ELCONV} \cdot (OSR + 1) + 1) / f_S$. OSR can be set between 8 and 1024, in powers of 2. N_{ELCONV} can be set to 1, 2, 4 or 8.
- (15) PGAs are reset after each writing operation to registers **RegAcCfg1-5**. The ADC must be started after a PGA or inputs common-mode stabilisation delay. This is done by writing bit $Start$ several cycles after PGA settings modification or channel switching. Delay between PGA start or input channel switching and ADC start should be equivalent to OSR (between 8 and 1024) number of cycles. This delay does not apply to conversions made without the PGAs.
- (16) Nominal (maximum) bias currents in PGAs and ADC, i.e. $IB_AMP_PGA[1:0] = '11'$ and $IB_AMP_ADC[1:0] = '11'$.
- (17) Bias currents in PGAs and ADC set to 3/4 of nominal values, i.e. $IB_AMP_PGA[1:0] = '10'$, $IB_AMP_ADC[1:0] = '10'$.
- (18) Bias currents in PGAs and ADC set to 1/2 of nominal values, i.e. $IB_AMP_PGA[1:0] = '01'$, $IB_AMP_ADC[1:0] = '01'$.
- (19) Bias currents in PGAs and ADC set to 1/4 of nominal values, i.e. $IB_AMP_PGA[1:0] = '00'$, $IB_AMP_ADC[1:0] = '00'$.

16.8.3 Linearity
16.8.3.1 Integral non-linearity

The integral non-linearity depends on the selected gain configuration. First of all, the non-linearity of the ADC (all PGA stages bypassed) is shown in Figure 16-8.

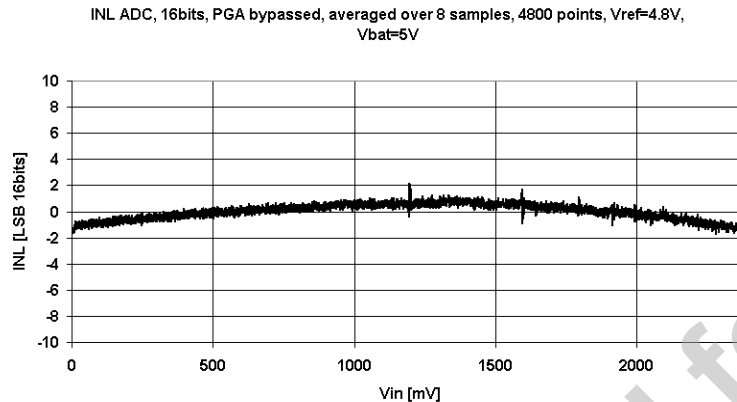

Figure 16-8. Integral non-linearity of the ADC (PGA disabled, reference voltage of 4.8V)

The different PGA stages have been designed to find the best compromise between the noise performance, the integral non-linearity and the power consumption. To obtain this, the first stage has the best noise performance and the third stage the best linearity performance. For large input signals (small PGA gains, i.e. up to about 50), the noise added by the PGA is very small with respect to the input signal and the second and third stage of the PGA should be used to get the best linearity. For small input signals (large gains, i.e. above 50), the noise level in the PGA is important and the first stage of the PGA should be used.

The following figures give the non-linearity for different gain settings of the PGA, selecting the appropriate stage to get the best noise and linearity performance. Figure 16-9 shows the non-linearity when the third stage is used with a gain of 1. It is of course not very useful to use the PGA with a gain of 1 unless it is used to compensate offset. By increasing the gain, the integral non-linearity becomes even smaller since the signal in the amplifiers reduces.

Figure 16-10 shows the non-linearity for a gain of 2. Figure 16-11 shows the non-linearity for a gain of 5. Figure 16-12 shows the non-linearity for a gain of 10. By comparing these figures to Figure 16-8, it can be seen that the third stage of the PGA does not add significant integral non-linearity.

Figure 16-13 shows the non-linearity for a gain of 20 and Figure 16-14 shows the non-linearity for a gain of 50. In both cases the PGA2 is used at a gain of 10 and the remaining gain is realized by the third stage. It can be seen again that the second stage of the PGA does not add significant non-linearity.

For gains above 50, the first stage PGA1 should be selected in stead of PGA2. Although the non-linearity in the first stage of the PGA is larger than in stage 2 and 3, the gain in stage 3 is now sufficiently high so that the non-linearity of the first stage does become negligible as is shown in Figure 16-15 for a gain of 100. Therefore, the first stage is preferred over the second stage since it has less noise.

Increasing the gain further up to 1000 will further increase the linearity since the signal becomes very small in the first two stages. The signal is full scale at the output of stage 3 and as shown in Figure 16-9 to Figure 16-12, this stage has very good linearity.

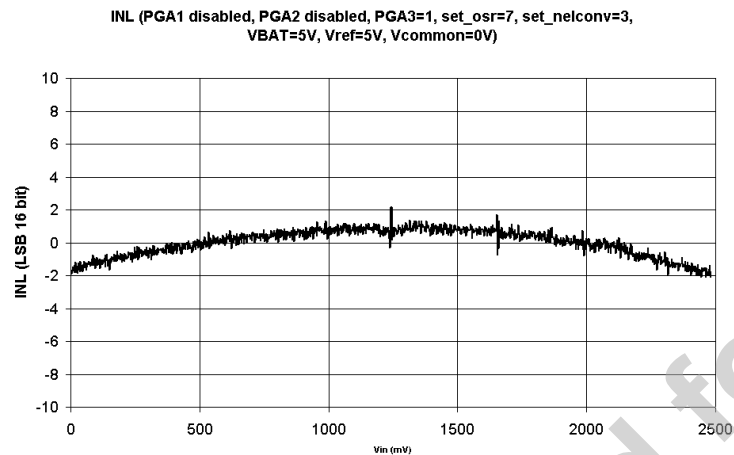

Figure 16-9. Integral non-linearity of the ADC and with gain of 1 (PGA1 and PGA2 disabled, PGA3=1, reference voltage of 5V)

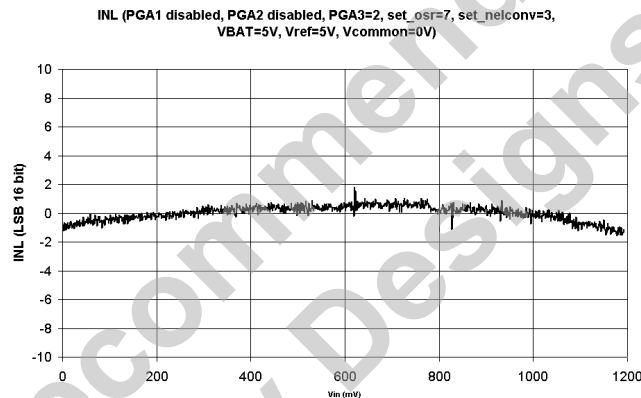

Figure 16-10. Integral non-linearity of the ADC and gain of 2 (PGA1 and PGA2 disabled, PGA3=2 reference voltage of 5V)

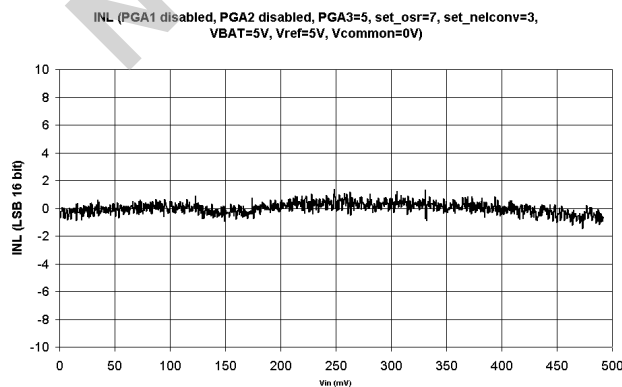

Figure 16-11. Integral non-linearity of the ADC and gain of 5 (PGA1 and PGA2 disabled, PGA3=5, reference voltage of 5V)

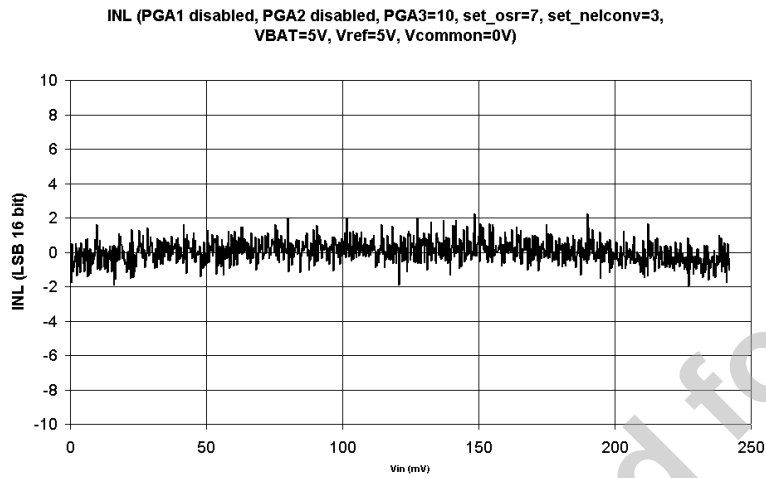

Figure 16-12. Integral non-linearity of the ADC and gain of 10 (PGA1 and PGA2 disabled, PGA3=10, reference voltage of 5V)

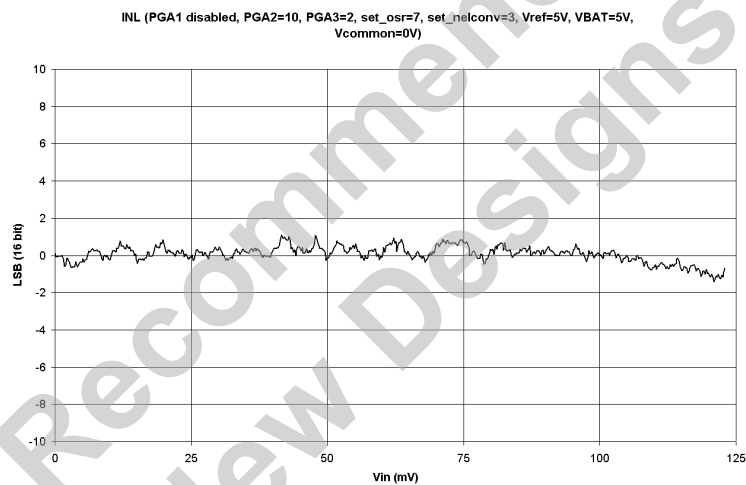

Figure 16-13. Integral non-linearity of the ADC and gain of 20 (PGA1 and PGA2=10, PGA3=2, reference voltage of 5V)

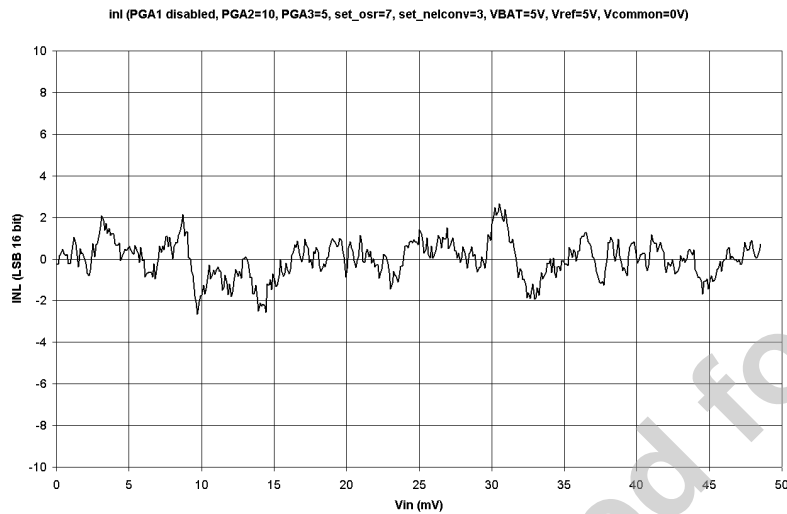

Figure 16-14. Integral non-linearity of the ADC and gain of 50 (PGA1 disabled, PGA2=10, PGA3=5, reference voltage of 5V)

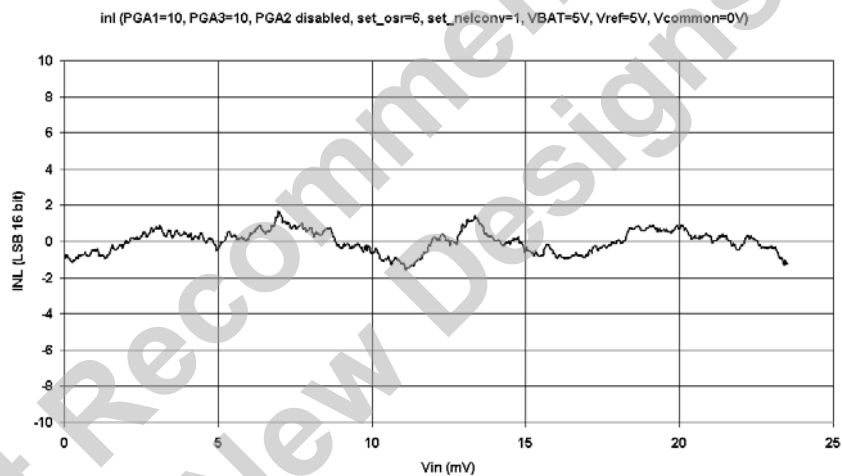

Figure 16-15. Integral non-linearity of the ADC and gain of 100 (PGA1=10 and PGA3=10, PGA2 disabled, reference voltage of 5V)

16.8.3.2 Differential non-linearity

The differential non-linearity is generated by the ADC. The PGA does not add differential non-linearity. Figure 16-16 shows the differential non-linearity.

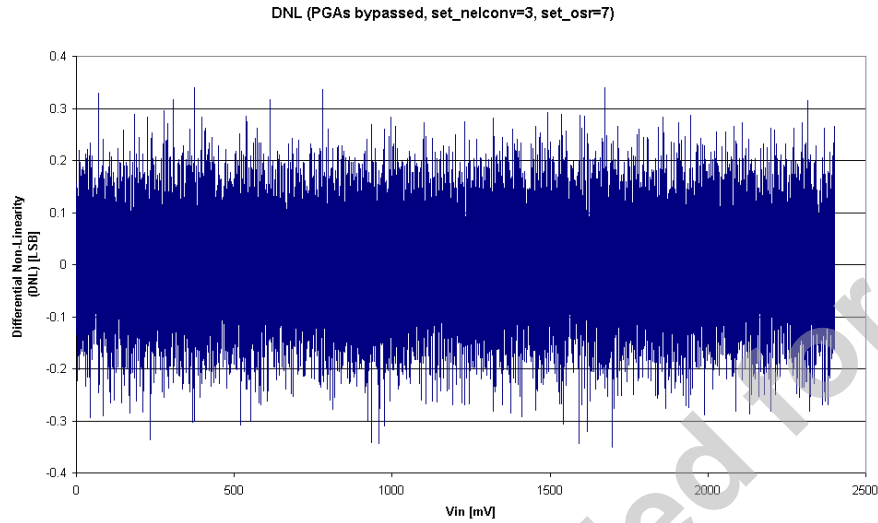

Figure 16-16. Differential non-linearity of the ADC converter.

16.8.4 Noise

Ideally, a constant input voltage V_{IN} should result in a constant output code. However, because of circuit noise, the output code may vary for a fixed input voltage. Thus, a statistical analysis on the output code of 1200 conversions for a constant input voltage was performed to derive the equivalent noise levels of PGA1, PGA2, and PGA3. The extracted rms output noise of PGA1, 2, and 3 are given in Table 16-27: standard output deviation and output rms noise voltage. Figure 16-17 shows the distribution for the ADC alone (PGA1, 2, and 3 bypassed). Quantization noise is dominant in this case, and, thus, the ADC thermal noise is below 16 bits.

The simple noise model of Figure 16-18(a) is used to estimate the equivalent input referred rms noise $V_{N,IN}$ of the acquisition chain in the model of Figure 16-18(b). This is given by the relationship:

$$V_{N,IN}^2 = \frac{(V_{N1} / GD_1)^2 + (V_{N2} / (GD_1 \cdot GD_2))^2 + (V_{N3} / (GD_1 \cdot GD_2 \cdot GD_3))^2}{(OSR \cdot N_{ELCONV})} \quad (V^2\text{rms}) \quad (\text{Eq. 21})$$

where V_{N1} , V_{N2} , and V_{N3} are the output rms noise figures of Table 16-27, GD_1 , GD_2 , and GD_3 are the PGA gains of stages 1 to 3 respectively. As shown in this equation, noise can be reduced by increasing OSR and N_{ELCONV} (increases the ADC averaging effect, but reduces noise).

Parameter	PGA1	PGA2	PGA3
Standard deviation at ADC output (LSB)	0.85	1.4	1.5
Output rms noise (μV) ¹	205 (V_{N1})	340 (V_{N2})	365 (V_{N3})

Note: see noise model of Figure 16-18 and equation Eq. 21.

Table 16-27. PGA noise measurements ($n = 16$ bits, $OSR = 512$, $N_{ELCONV} = 2$, $V_{REF} = 5V$)

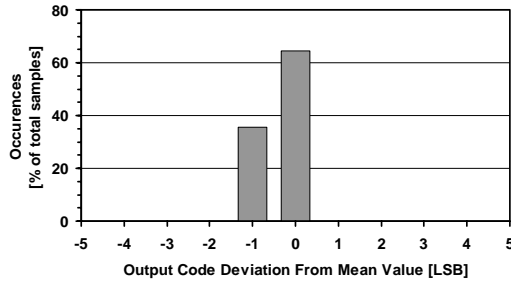

Figure 16-17. ADC noise (PGA1, 2 & 3 bypassed, OSR=512, $N_{ELCONV}=2$)

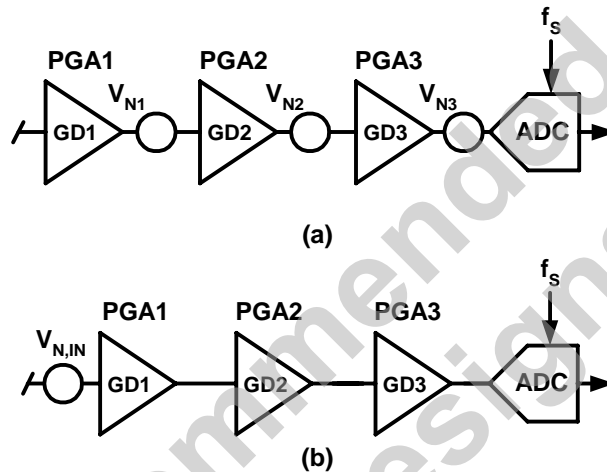

Figure 16-18. (a) Simple noise model for PGAs and ADC and (b) total input referred noise

As an example, consider the system where: $GD_2 = 10$ ($GD_1 = 1$; PGA3 bypassed), $OSR = 512$, $N_{ELCONV} = 2$, $V_{REF} = 5V$. In this case, the noise contribution V_{N1} of PGA1 is dominant over that of PGA2. Using equation Eq. 21, we get: $V_{N,IN} = 6.4\mu V$ (rms) at the input of the acquisition chain, or, equivalently, 0.85 LSB at the output of the ADC. Considering a 0.2V (rms) maximum signal amplitude, the signal-to-noise ratio is 90dB.

Noise can also be reduced by implementing a software filter. By making an average on a number of subsequent measurements, the apparent noise is reduced the square root of the number of measurement used to make the average.

16.8.5 Gain Error and Offset Error

Gain error is defined as the amount of deviation between the ideal transfer function (theoretical equation Eq. 18) and the measured transfer function (with the offset error removed).

The actual gain of the different stages can vary depending on the fabrication tolerances of the different elements. Although these tolerances are specified to a maximum of $\pm 3\%$, they will be most of the time around $\pm 0.5\%$. Moreover, the tolerances between the different stages are not correlated and the probability to get the maximal error in the same direction in all stages is very low. Finally, these gain errors can be calibrated by the software at the same time with the gain errors of the sensor for instance.

Figure 16-19 shows gain error drift vs. temperature for different PGA gains. The curves are expressed in % of Full-Scale Range (FSR) normalized to 25°C.

Offset error is defined as the output code error for a zero volt input (ideally, output code = 0). The offset of the ADC and the PGA1 stage are completely suppressed if $N_{ELCONV} > 1$.

The measured offset drift vs. temperature curves for different PGA gains are depicted in Figure 16-20. The output offset error, expressed in LSB for 16-bit setting, is normalized to 25°C. Notice that if the ADC is used alone, the output offset error is below ± 1 LSB and has no drift.

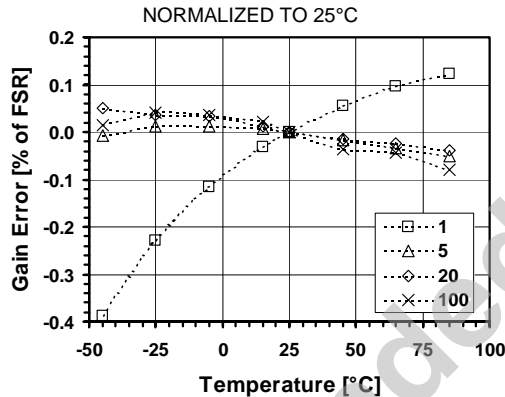

Figure 16-19. Gain error vs. temperature for different PGA gains

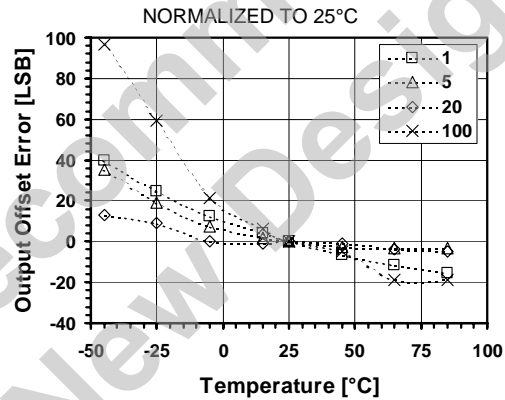

Figure 16-20. Offset error vs. temperature for different PGA gains

16.8.6 Power Consumption

Figure 16-21 plots the variation of quiescent current consumption with supply voltage V_{DD} , as well as the distribution between the 3 PGA stages and the ADC (see Table 16-28). As shown in Figure 16-22, if lower sampling frequency is used, the quiescent current consumption can be lowered by reducing the bias currents of the PGAs and the ADC with registers IB_AMP_PGA [1:0] and IB_AMP_ADC [1:0]. (In Figure 16-22, IB_AMP_PGA/ADC [1:0] = '11', '10', '00' for $f_s = 500, 250, 62.5$ kHz respectively.)

Quiescent current consumption vs. temperature is depicted in Figure 16-23, showing a relative increase of nearly 40% between -45 and +85°C. Figure 16-24 shows the variation of quiescent current consumption for different frequency settings of the internal RC oscillator. It can be seen that the quiescent current varies by about 20% between 100kHz and 2MHz.

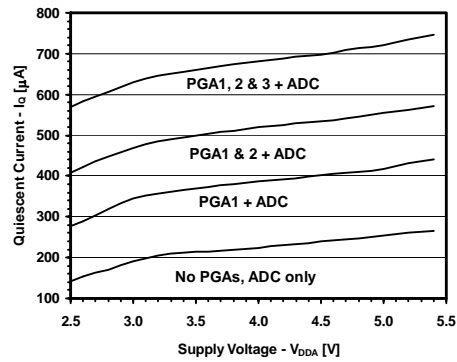

Figure 16-21. Quiescent current consumption vs. supply voltage

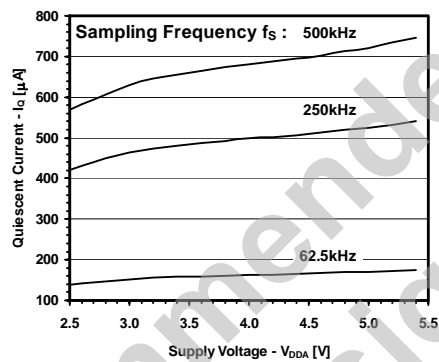

Figure 16-22. Quiescent current consumption vs. supply voltage for different sampling frequencies

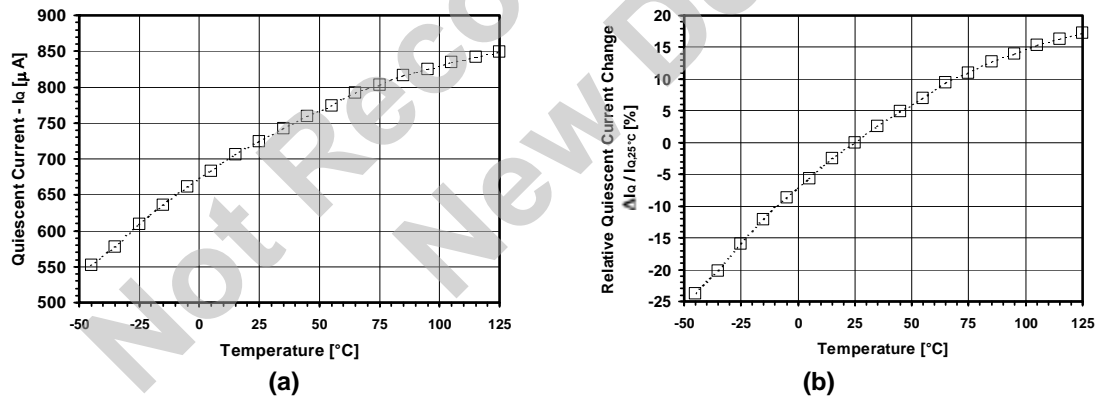

Figure 16-23. (a) Absolute and (b) relative change in quiescent current consumption vs. temperature

Supply	ADC	PGA1	PGA2	PGA3	TOTAL	Unit
V _{DD} = 5V	250	165	130	175	720	μA
V _{DD} = 3V	190	150	120	160	620	μA

Table 16-28. Typical quiescent current distributions in acquisition chain (n = 16 bits, f_s = 500kHz)

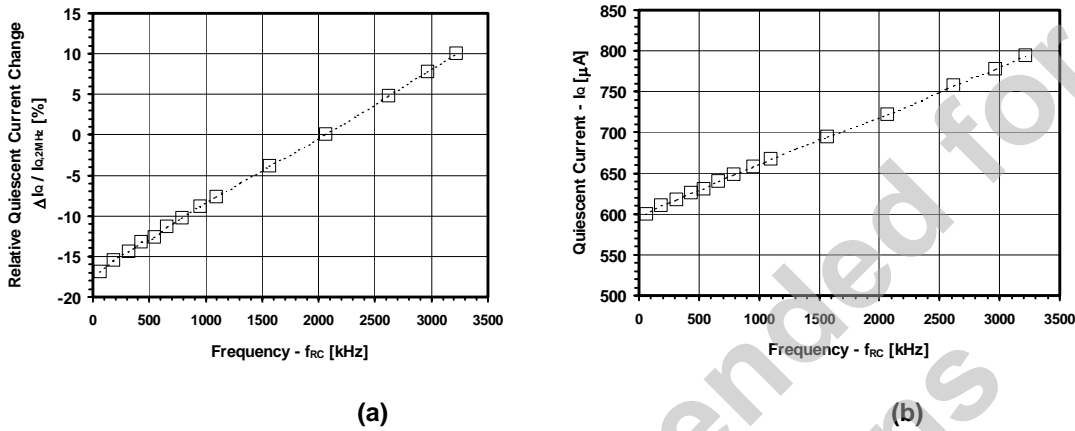

Figure 16-24. (a) Absolute and (b) relative change in quiescent current consumption vs. RC oscillator frequency (all PGAs active, V_{DD} = 5V)

16.8.7 Power Supply Rejection Ratio

Figure 16-25 shows power supply rejection ratio (PSRR) at 3V and 5V supply voltage, and for various PGA gains. PSRR is defined as the ratio (in dB) of voltage supply change (in V) to the change in the converter output (in V). PSRR depends on both PGA gain and supply voltage V_{DD}.

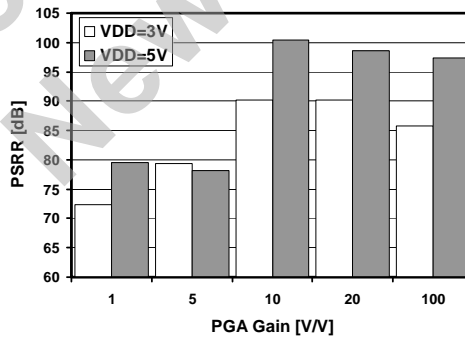

Figure 16-25. Power supply rejection ratio (PSRR)

Supply	GAIN = 1	GAIN =5	GAIN = 10	GAIN = 20	GAIN =100	Unit
V _{DD} = 5V	79	78	100	99	97	dB
V _{DD} = 3V	72	79	90	90	86	dB

Table 16-29. PSRR (n = 16 bits, V_{IN} = V_{REF} = 2.5V, f_S = 500kHz)

16.9 Application Hints

16.9.1 Input Impedance

The PGAs of the acquisition chain employ switched-capacitor techniques. For this reason, while a conversion is done, the input impedance on the selected channel of the PGAs is inversely proportional to the sampling frequency f_s and to stage gain as given in equation 22.

$$Z_{in} \geq \frac{768 \cdot 10^9 \Omega \text{Hz}}{f_s \cdot \text{gain}} \quad (\text{Eq. 22})$$

The input impedance observed is the input impedance of the first PGA stage that is enabled or the input impedance of the ADC if all three stages are disabled.

PGA1 (with a gain of 10), PGA2 (with a gain of 10) and PGA3 (with a gain of 10) each have a minimum input impedance of 150k Ω at $f_s = 512\text{kHz}$ (see Specification Table). Larger input impedance can be obtained by reducing the gain and/or by reducing the sampling frequency. Therefore, with a gain of 1 and a sampling frequency of 100kHz, $Z_{in} > 7.6\text{M}\Omega$.

The input impedance on channels that are not selected is very high (>100M Ω).

16.9.2 PGA Settling or Input Channel Modifications

PGAs are reset after each writing operation to registers **RegAccfg1-5**. Similarly, input channels are switched after modifications of **AMUX[4:0]** or **VMUX**. To ensure precise conversion, the ADC must be started after a PGA or inputs common-mode stabilization delay. This is done by writing bit **START** several cycles after PGA settings modification or channel switching. Delay between PGA start or input channel switching and ADC start should be equivalent to **OSR** (between 8 and 1024) number of cycles. This delay does not apply to conversions made without the PGAs.

If the ADC is not settled within the specified period, there is most probably an input impedance problem (see previous section).

16.9.3 PGA Gain & Offset, Linearity and Noise

Hereafter are a few design guidelines that should be taken into account when using the ZoomingADC™:

- 1) Keep in mind that increasing the overall PGA gain, or "zooming" coefficient, improves linearity but degrades noise performance.
- 2) Use the minimum number of PGA stages necessary to produce the desired gain ("zooming") and offset. Bypass unnecessary PGAs.
- 3) For high gains (>50), use PGA stage 1. For low gains (<50) use stages 2 and 3.
- 4) For the lowest noise, set the highest possible gain on the first (front) PGA stage used in the chain. For example, in an application where a gain of 20 is needed, set the gain of PGA2 to 10, set the gain of PGA3 to 2.

- 4) For highest linearity and lowest noise performance, bypass all PGAs and use the ADC alone (applications where no "zooming" is needed); i.e. set **ENABLE** [3:0] = '0001'.
- 5) For low-noise applications where power consumption is not a primary concern, maintain the largest bias currents in the PGAs and in the ADC; i.e. set **IB_AMP_PGA** [1:0] = **IB_AMP_ADC** [1:0] = '11'.
- 6) For lowest output offset error at the output of the ADC, bypass PGA2 and PGA3. Indeed, PGA2 and PGA3 typically introduce an offset of about 5 to 10 LSB (16 bit) at their output. Note, however, that the ADC output offset is easily calibrated out by software.

16.9.4 Frequency Response

The incremental ADC is an over-sampled converter with two main blocks: an analog modulator and a low-pass digital filter. The main function of the digital filter is to remove the quantization noise introduced by the modulator. As shown in Figure 16-26, this filter determines the frequency response of the transfer function between the output of the ADC and the analog input V_{IN} . Notice that the frequency axes are normalized to one elementary conversion period OSR/f_s . The plots of Figure 16-26 also show that the frequency response changes with the number of elementary conversions N_{ELCONV} performed. In particular, notches appear for $N_{ELCONV} \geq 2$. These notches occur at:

$$f_{NOTCH}(i) = \frac{i \cdot f_s}{OSR \cdot N_{ELCONV}} \quad (\text{Hz}) \quad \text{for } i = 1, 2, \dots, (N_{ELCONV} - 1) \quad (\text{Eq. 23})$$

and are repeated every f_s/OSR .

Information on the location of these notches is particularly useful when specific frequencies must be filtered out by the acquisition system. For example, consider a 5Hz-bandwidth, 16-bit sensing system where 50Hz line rejection is needed. Using the above equation and the plots below, we set the 4th notch for $N_{ELCONV} = 4$ to 50Hz, i.e. $1.25 \cdot f_s/OSR = 50\text{Hz}$. The sampling frequency is then calculated as $f_s = 20.48\text{kHz}$ for $OSR = 512$. Notice that this choice yields also good attenuation of 50Hz harmonics.

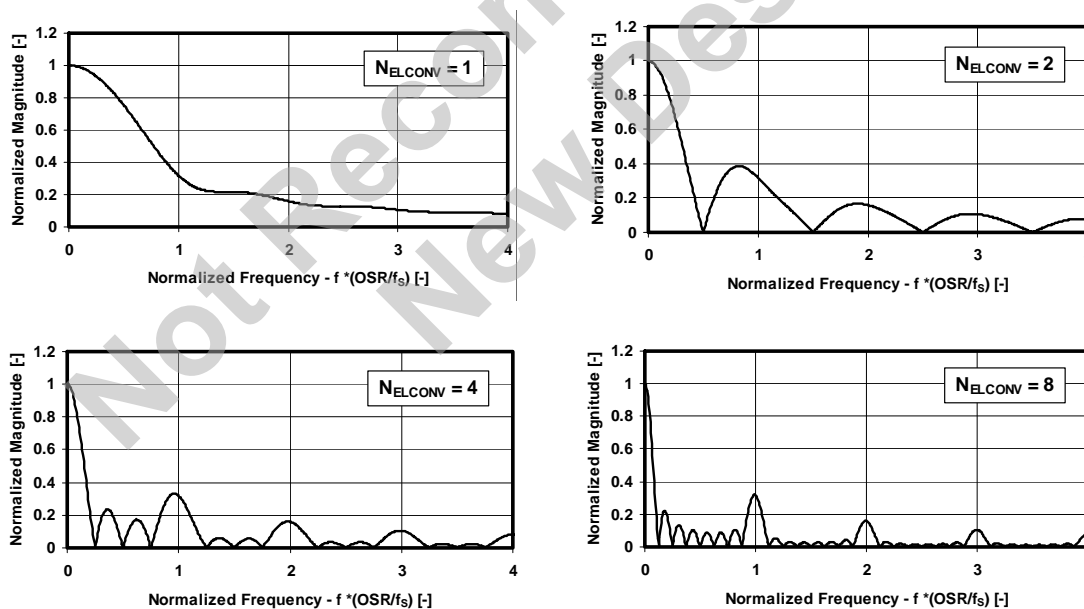

Figure 16-26. Frequency response: normalized magnitude vs. frequency for different N_{ELCONV}

16.9.5 Power Reduction

The ZoominADC™ is particularly well suited for low-power applications. When very low power consumption is of primary concern, such as in battery operated systems, several parameters can be used to reduce power consumption as follows:

- 1) Operate the acquisition chain with a reduced supply voltage V_{DD} .
- 2) Disable the PGAs which are not used during analog-to-digital conversion with **ENABLE [3:0]**.
- 3) Disable all PGAs and the ADC when the system is idle and no conversion is performed.
- 4) Use lower bias currents in the PGAs and the ADC using the control words **IB_AMP_PGA [1:0]** and **IB_AMP_ADC [1:0]**. (This reduces the maximum sampling frequency according to Table 16-26.)
- 5) Reduce internal RC oscillator frequency and/or sampling frequency.

Finally, remember that power reduction is typically traded off with reduced linearity, larger noise and slower maximum sampling speed.

Not Recommended for
New Designs

17. Vmult (Voltage Multiplier)

17.1	Features	17-2
17.2	Overview	17-2
17.3	Control register	17-2
17.4	External component	17-2

Not Recommended for
New Designs

17.1 Features

- Generates a voltage that is higher or equal to the supply voltage.
- Can be easily enabled or disabled

17.2 Overview

The Vmult block generates a voltage (called “Vmult”) that is higher or equal to the supply voltage. This output voltage is used in the acquisition chain.

The voltage multiplier should be on (bit **ENABLE** in **RegVmultCfq0**) when using the acquisition chain or analog properties of the Port B while VBAT is below 3V. If the multiplier is enabled, the external capacitor on the pin VMULT is mandatory.

The source clock of Vmult is selected by **FIN[1:0]** in **RegVmultCfq0**. It is strongly recommended to use the same settings as in the ADC.

17.3 Control register

There is only one register in the Vmult. Table 177-1 describes the bits in the register.

Pos.	RegVmultCfq0	rw	Reset	Function
2	Enable	rw	0 resetsystem	enable of the vmult '1' : enabled '0' : disabled
1-0	Fin	rw	0 resetsystem	system clock division factor '00' : 1/2, '01' : 1/4, '10' : 1/16, '11' : 1/64

Table 177-1. **RegVmultCfq0**

17.4 External component

When the multiplier is enabled, a capacitor has to be connected to the VMULT pin. If the multiplier is disabled, the pin may remain floating.

	Min.	Max.		Note
Capacitor on VMULT	1.0	3.0	nF	

18. Signal D/A (DAS)

18.1	Features	18-2
18.2	Overview of Signal DAC - The generic DAC	18-2
18.3	Registers Map	18-3
18.4	The D/A description	18-4
18.4.1	What is a noise shaper ?	18-4
18.4.2	Advantages/disadvantages	18-4
18.4.3	D/A setup and resolution	18-5
18.5	Amplifier	18-7
18.6	Low pass filter	18-8
18.6.1	First order low pass filter	18-8
18.6.2	Second order low pass filter	18-9
18.7	4-20mA loop	18-10
18.7.1	2-wire loop with first order filtering	18-10
18.7.2	2-wire loop with second order filtering	18-12

18.1 Features

- 16-bits maximum input word width
- Synchronization mechanism to guarantee data integrity when writing LSB and MSB 8-bits data
- Programmable noise shaper order: second, first or order zero
- Programmable PWM modulation between 4 and 11-bits
- Programmable clock input frequency: f_{in} or $f_{in}/2$
- Programmable output polarity: active high or low
- On chip amplifier for analog filtering, voltage output or 4-20 mA loop

18.2 Overview of Signal DAC - The generic DAC

The generic DAC block consists of two major parts: the noise shaper (sigma-delta modulator) and the PWM modulator as shown in Figure 18-1.

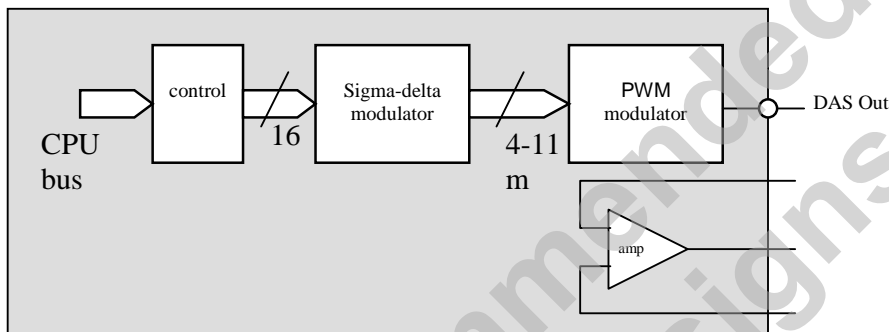

Figure 18-1. General block diagram

A D/A converter that is built with a digital PWM modulator needs a high clock frequency for a small signal bandwidth. For a 10 bit digital PWM modulator for instance, a 10 bit counter is needed in order to create a pulse with a resolution of 1024. This means that, in case an infinitely sharp analog output filter is used, the clock frequency has to be at least 1024 times the output bandwidth. In practice however, in order to be able to build the analog filter, the clock frequency needs to be much higher.

In order to reduce this frequency requirement, the input digital word is broken down into n words with a smaller width m by a noise shaper so that the “average” (average for first order noise shaper, more complicated for higher order noise shapers) value of the n m -bit words represents the full width input code. Instead of 1 pulse with the full resolution, the PWM modulator now generates n pulses with a smaller resolution m . This increases the output pulse repetition frequency with a factor n for identical clock frequency. Therefore, the analog output filtering is easier to implement. Higher order noise shapers (order >1) allow to decrease the clock frequency for identical signal bandwidth.

Another advantage is that the signal distortion is less dependent on the signal value. A disadvantage is however, that the output signal after filtering is more dependent on the rise and fall times of the PWM output since there are many more pulses.

The maximum word width at the input is 16-bit. If the word is narrower, 0’s have to be added after the LSB. In order to maintain maximum flexibility, the order of the noise shaper and the resolution of the PWM modulation are programmable by writing the codes **CodeLmax** and **NsOrder** to the configuration register. The possible noise shaper order is 0 (which means no noise shaping), 1 or 2. The possible PWM modulation resolution m can be set between 4 and 11.

18.3 Registers Map

All registers are reset with the system reset.

The contents of the registers **RegDasInLsb** and **RegDasInMsb** are transferred to the D/A converter when after data have been written into **RegDasInMsb**. Therefore, in order to maintain the synchronisation between the LSB and MSB, the LSB should always be written before the MSB.

Pos.	RegDasInLsb	rw	reset	function
7:0	DasInLsb(7:0)	rw	0 resetsystem	Data to convert LSB

Table 18-1. **RegDasInLsb**

Pos.	RegDasInMsb	rw	reset	function
7:0	DasInMsb(7:0)	rw	0 resetsystem	Data to convert MSB

Table 18-2. **RegDasInMsb**

Pos.	RegDasCfg0	rw	reset	function
7:6	NsOrder(1:0)	rw	00 resetsystem	Noise Shaper order 00 : order 0 01 : order 1 1x : order 2
5:3	CodeLmax(2:0)	rw	000 resetsystem	PWM pulse resolution : 000 : 4 bits 001 : 5 bits 010 : 6 bits 011 : 7 bits 100 : 8 bits 101 : 9 bits 110 : 10 bits 111 : 11 bits
2:1	Enable(1:0)	rw	00 resetsystem	Bit 0 : enables the D/A Bit 1 : enables the amplifier
0	Fin	rw	0 resetsystem	Input frequency of modulator as a fraction of oscillator frequency 0 : $1.f_{RC}$, 1 : $\frac{1}{2}.f_{RC}$

Table 18-3. **RegDasCfg0**

Pos.	RegDasCfg1	rw	reset	function
7:2	-	rw	000000	Unused
1	BW	rw	0 resetsystem	Amplifier bandwidth 0 : small bandwidth 1 : large bandwidth
0	INV	rw	0 resetsystem	Inverts the PWM output 0 : normal, active high 1 : inverted, active low

Table 18-4. **RegDasCfg1**

18.4 The D/A description

The D/A converter consists of 2 parts: a classic PWM modulator which is preceded by a noise shaper (Figure 18-1). The PWM signal has then to be low pass filtered using the amplifier and external components to obtain the analog signal.

18.4.1 What is a noise shaper?

The major disadvantage of using a PWM modulator to generate a high resolution analog signal is that it requires a high ratio between the PWM switching frequency and the useful bandwidth of the output analog signal after low pass filtering.

Example: assuming the switching frequency of the PWM modulator is 1MHz and one wants to resolve 16 bit, i.e. $2^{16}=65536$ steps. In this case, the PWM has to code each step in increments of $1\mu s=1/1MHz$ and needs therefore $65536\mu s$ per pulse. This means that the PWM pulse repetition rate is $1/65536\mu s=15.25Hz$. So, even with a higher order low pass filter, more than 1 frequency decade will be required to filter the PWM signal down to a 16 bit accurate analog signal. This leaves a useful bandwidth below 1Hz.

The goal of the noise shaper is to reduce the ratio between the PWM switching frequency and the useful bandwidth. The noise shaper will not reduce the "truncation noise" and "PWM modulation noise" but move it to higher frequencies. It "shapes" the frequency spectrum ("noise") of the generated PWM signal, hence its name. In practice, the noise shaper allows the generation of a signal with a given resolution using a PWM modulator that has a lower resolution. The noise shaper then generates a series of different subsequent low resolution codes for the PWM so that the average value corresponds to the high resolution code.

The first order noise shaper interpolates between two adjacent PWM codes to obtain a higher resolution. The second order noise shaper can use non-adjacent PWM codes.

Example for first order noise shaper: assuming again the resolution of 16 bits using a 1MHz PWM switching frequency using the noise shaper with order 1. If a PWM modulator with 4 bits, i.e. 16 steps is used, the PWM repetition frequency becomes then $1MHz/16=62.5kHz$. The PWM modulator can convert only the 4 MSB's of the 16 bit input such as h0000, h1000 until hF000. In order to convert the code h5800, which is between h5000 and h6000? In this case, the first order noise shaper will interpolate by presenting alternatively the code h5 and h6 to the PWM so that after filtering a signal is obtained halfway between the normal PWM steps. To convert the code h5400, it will present h5 3 times and h6 once to the PWM and so on. It is clear from this that the PWM repetition frequency is much higher than for the simple PWM and can be filtered out more easily. The quantization noise frequency will depend on the code to be converted: for this example for instance we need two PWM pulses to implement the code h5800, but we need four to implement h5400 etc.

Example for second order noise shaper: if we use the same conditions as for the example above, we will obtain the same PWM repetition frequency. However, to implement the code h5400, the noise shaper now can present the following sequence to the PWM modulator: h6, h5, h6, h4. This increases the frequency components at the PWM pulse repetition frequency and $\frac{1}{2}$ of the PWM pulse repetition frequency but at the same time reduces energy at $\frac{1}{4}$ of the PWM pulse repetition frequency with respect to the first order noise shaper. The low pass cut-off frequency can therefore be higher than for a first order noise shaper.

A disadvantage of the second order noise shaper is however that the resolution will drop when the code is very close to h0000 or hFFFF.

Example: if we assume the same conditions as above, but we want to convert the code h0400. It is now impossible to use a similar sequence as above (which would be h1, h0, h1, h(-1)) due to saturation of the code. There is no choice left but the sequence h1 h0 h0 h0 which is the same sequence as in the first order noise shaper.

18.4.2 Advantages/disadvantages

Advantages:

Using a high order noise shaper together with a PWM modulator with low resolution reduces the ratio between the low pass cut off frequency and the PWM switching frequency for the same total resolution. This can be used to

increase the output signal bandwidth or to reduce the PWM switching frequency and therefore the power consumption of the D/A. Signal distortion is less dependent on the signal value.

Disadvantages:

Using a high order noise shaper together with a PWM modulator with low resolution will use lots of short pulses instead of 1 long pulse. The D/A is therefore more sensitive to rise and fall times of the PWM resulting in a slightly higher non-linearity and temperature dependence. The second order noise shaper also has a reduced resolution for codes very close to zero or full scale.

18.4.3 D/A setup and resolution

In this section, the resolution that can be obtained with the D/A as a function of settings is calculated. These calculations are based on the quantization and PWM modulation noise. Noise on the reference, i.e. the supply voltage is not taken into account. High frequency noise on the supply voltage can be filtered by the output low pass filter, but in band noise on the reference will show up in the output signal with amplitude that will depend on the signal value. Therefore, when using the D/A, one should take care to minimize the switching activity on the digital ports and/or to limit the load on these ports.

18.4.3.1 Noise shaper of order 0

Setting the noise shaper to order 0 (**NsOrder=00**), reduces the D/A to a regular PWM. Two parameters are setting the resolution of the D/A: the resolution of the modulator itself and the amount of low pass filtering at the output.

The modulation width m of the PWM modulator is given by:

$$m = 4 + \text{CodeLmax}$$

The cut-off frequency f_c of the low pass filter required to get the resolution is calculated below. The PWM modulator repetition frequency f_{PWM} can be calculated as a function of the selected modulation width m , the frequency of the RC oscillator of the circuit f_{RC} and the selected frequency division set by **Fin** :

$$f_{PWM} = \frac{f_{RC} \cdot \left(\frac{1}{1 + \text{Fin}} \right)}{2^m}$$

To obtain an analog signal with the required resolution, the PWM signal has to be low pass filtered. The resolution that can be obtained depends on the filter order and the ratio between the PWM modulation frequency f_{PWM} and the filter cut-off frequency f_c . For a low pass filter of LpOrder, we obtain:

$$resolution_{PWM} = LpOrder \cdot \log_2 \left(\frac{f_{PWM}}{f_c} \right)$$

The total resolution of the D/A is then the minimal value of both criteria:

$$resolution = \min(m, resolution_{PWM})$$

In Table 18-5 the required cut-off frequency of the low pass filter is shown for a noise shaper of order 0 as a function of the desired resolution for both a first and second order low pass filter. The PWM modulation factor m should be chosen equal to the desired resolution.

resolution (bit)	m	f _c for LpOrder=1 (Hz)	f _c for LpOrder=2 (Hz)
4	4	7812	31250
5	5	1953	11048
6	6	488	3906
7	7	122	1381
8	8	30	488
9	9	7.6	172
10	10	1.9	61
11	11	0.48	22

Table 18-5. Signal bandwidth as a function of the required resolution for the PWM without noise shaper (Fin=0, NsOrder=00, f_{RC}=2MHz).

18.4.3.2 Noise shaper of order 1 or 2

The calculation on the required low pass cut-off frequency given in 18.4.3.1 remains valid in this case. However, the noise shaper allows using smaller PWM modulation for the same resolution. This increases the PWM modulation frequency and as a consequence increases the output bandwidth.

An additional criterion however shows up: the filtering of the quantization noise. As can be seen from the examples in 18.4.1, the interpolation between PWM codes generated by the noise shaper introduce sequences at frequencies below the PWM modulation frequency. Assuming a low pass filter that has at least the same order as the noise shaper, the resolution is given by (NsOrder≥1) :

$$resolution_{quant} = 0.359 + m + NsOrder \cdot \left(\log_2 \left(\frac{f_{PWM}}{f_c} \right) - 2.65 \right)$$

The total resolution of the D/A is then the minimal of both criteria:

$$resolution = \min(resolution_{quant}, resolution_{PWM})$$

Table 18-6 and Table 18-7 show the signal bandwidth that can be obtained as a function of required resolution and PWM modulation for first and second order noise shapers. It can be seen that these options are useful to obtain high resolution using low PWM modulation m. For high PWM modulation m, the resolution is limited by the PWM modulator and adding a noise shaper does not change anything.

NsOrder=1, f_{RC}=2MHz, Fin=0, LpOrder=2

Resolution (bit)	PWM modulation m							
	4	5	6	7	8	9	10	11
8	1596.4	1596.4	1596.4	976.6	488.3	244.1	122.1	61.0
9	798.2	798.2	798.2	690.5	345.3	172.6	86.3	43.2
10	399.1	399.1	399.1	399.1	244.1	122.1	61.0	30.5
11	199.5	199.5	199.5	199.5	172.6	86.3	43.2	21.6
12	99.8	99.8	99.8	99.8	99.8	61.0	30.5	15.3
13	49.9	49.9	49.9	49.9	49.9	43.2	21.6	10.8
14	24.9	24.9	24.9	24.9	24.9	24.9	15.3	7.6
15	12.5	12.5	12.5	12.5	12.5	12.5	10.8	5.4
16	6.2	6.2	6.2	6.2	6.2	6.2	6.2	3.8

Table 18-6. Low pass cut-off frequency as a function of the selected PMW modulation and required resolution for a first order noise shaper.

NsOrder=2, f_{RC}=2MHz, Fin=0, LpOrder=2

Resolution (bit)	PWM modulation m							
	4	5	6	7	8	9	10	11
8	5638.4	3906.3	1953.1	976.6	488.3	244.1	122.1	61.0
9	3986.9	2762.1	1381.1	690.5	345.3	172.6	86.3	43.2
10	2819.2	1953.1	976.6	488.3	244.1	122.1	61.0	30.5
11	1993.5	1381.1	690.5	345.3	172.6	86.3	43.2	21.6
12	1409.6	976.6	488.3	244.1	122.1	61.0	30.5	15.3
13	996.7	690.5	345.3	172.6	86.3	43.2	21.6	10.8
14	704.8	488.3	244.1	122.1	61.0	30.5	15.3	7.6
15	498.4	345.3	172.6	86.3	43.2	21.6	10.8	5.4
16	352.4	244.1	122.1	61.0	30.5	15.3	7.6	3.8

Table 18-7. Low pass cut-off frequency as a function of the selected MPW modulation and required resolution for a second order noise shaper.

The output range of the D/A is for code 0h0000 is VSS and for code 0hFFFF is (VBAT-VSS)(2^m-1)/2^m.

18.5 Amplifier

The amplifier can be used to implement the low pass filter and/or a 4-20mA loop. The amplifier is enabled using the bit **Enable(1)**=1. The amplifier has two different modes selected by the bit **BW**: a low frequency mode (**BW**=0) that allows driving a high capacitive load and a high frequency mode (**BW**=1).

The first mode is particularly adapted when a voltage output is used. The second mode is more adapted for a 4-20mA loop since loads are small and higher bandwidth is required to reject current consumption changes in the loop.

Table 18-8 shows the specification of the amplifier.

Note that the amplifier can not be used to generate signals that are larger than the supply voltages VBAT and VSS since the amplifier inputs and outputs are clamped to these voltages. The amplifier inputs and outputs should stay within the input and output ranges specified below.

sym	description	min	typ	max	unit	Comment
gain	gain at DC	80	100		dB	1
GBW ₀	gain bandwidth product	25	70		kHz	6
C _{L0}	capacitive load			5	nF	6
GBW ₁	gain bandwidth product	250	450		kHz	7
C _{L1}	capacitive load			200	pF	7
φ _m	phase margin	55	65		°	8
R _L	resistive load	5			kΩ	5
SR	slew rate	10	30		kV/s	9
CMR	common mode input range	VSS-0.2		VBAT-1.2	V	2
OR	output range	VSS+0.2		VBAT-0.2	V	
V _{off}	offset			±5	mV	
CMRR	common mode rejection	60			dB	3
noise	integrated input noise		50	100	uVrms	
PSRR	power supply rejection ratio	20	60		dB	4
I _{quie}	quiescent bias current		150		uA	
I _{off}	off current			1	uA	

1. For the minimal resistive load and the maximal capacitive load
2. The amplifier common mode is VSS in the 4-20mA loop.
3. At DC
4. At DC. Only a low rejection ratio is needed since the D/A output refers directly to the power supplies.
5. Short circuit protection at >3mA.
6. GBW when the maximal load is cl0 and with the bit **BW**=0
7. GBW when the maximal load is cl1 and with the bit **BW**=1
8. In both cases **BW**=0 and **BW**=1 for the maximal capacitive load and the minimal resistive load.
9. For maximal load C_{L0}, **BW**=0 and maximal resistive load R_L

Table 18-8. Specification of the amplifier.

18.6 Low pass filter

Several low pass filters are proposed here as examples. Other filter types are possible depending on the features or constraints of the application.

If the filter is inverting the signal, the bit **INV** can be used to invert the D/A output. This inversion does not need to be done by calculation.

A first or second order low pas filter can be built with the amplifier. If higher order filters are needed, additional first or second order sections can be added using external amplifiers.

18.6.1 First order low pass filter

Figure 18-2 shows a possible implementation of a first order low pass filter. Ideally, the analog ground should be halfway between VBAT and VSS. The gain *G* and cut-off frequency *f_c* of such a filter are given by:

$$G = \frac{R_2}{R_1}$$

$$f_c = \frac{1}{2\pi R_2 C}$$

As an example, to obtain a 1kHz filter with unity gain, we can choose C=1nF and R1=R2=150kΩ.

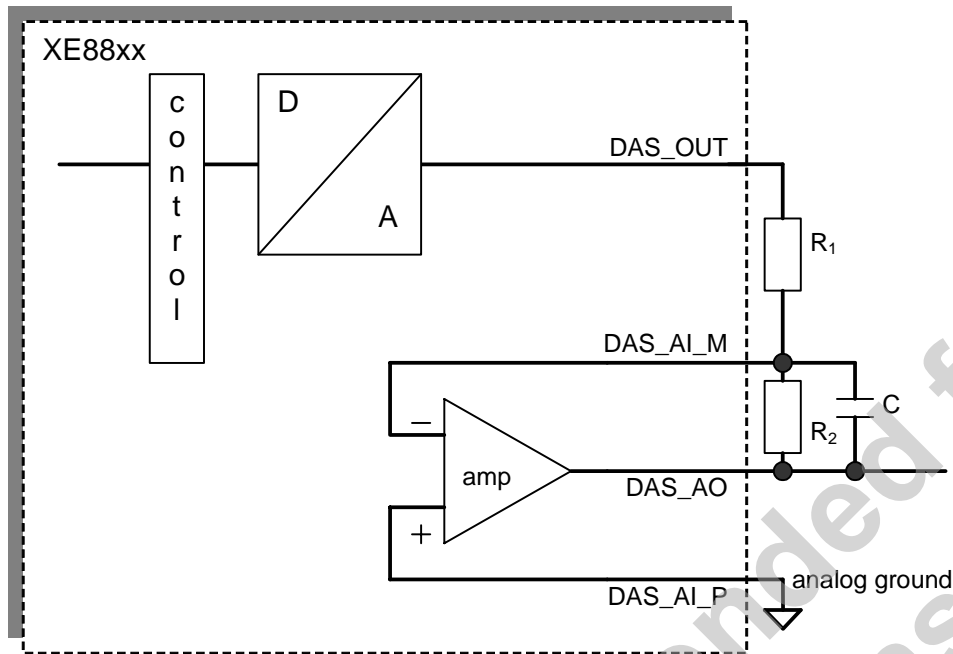

Figure 18-2. First order low pass filter.

18.6.2 Second order low pass filter

Figure 18-3 shows an example of a second order low pass filter using the multi-feedback architecture. The gain G , cut-off frequency f_c and the damping factor ξ (or quality factor Q) as a function of the factors k and m (see Figure 18-3) are given by:

$$G = -k$$

$$\xi = \frac{1}{2Q} = \frac{(n+1)\sqrt{km}}{2\sqrt{n}}$$

$$f_c = \frac{1}{2\pi RC\sqrt{kmn}}$$

For a second order Butterworth filter, $\xi = \sqrt{2}/2$. For smaller damping factors, the filter is under damped resulting in overshoots on the step response. For higher damping factors, the filter is over damped resulting in a smooth but slower step response.

An example of a 1dB ripple Chebychev filter with a cut-off frequency of about 1.5kHz and a DC gain of 1 is given by choosing $m=0.22$, $k=1$, $n=0.5$, $R=330k\Omega$ and $C=1nF$. The resistor nR can be rounded to 180k Ω .

A 60Hz unity gain low pass Butterworth filter can be built choosing $R=180k\Omega$, $C=12nF$, $k=1$, $m=0.183$, $n=8.33$.

Note that parasitic capacitors between the DAS_OUT node and the filter output DAS_AO will adversely affect the high frequency behavior of the filter. Care should be taken when routing these signals.

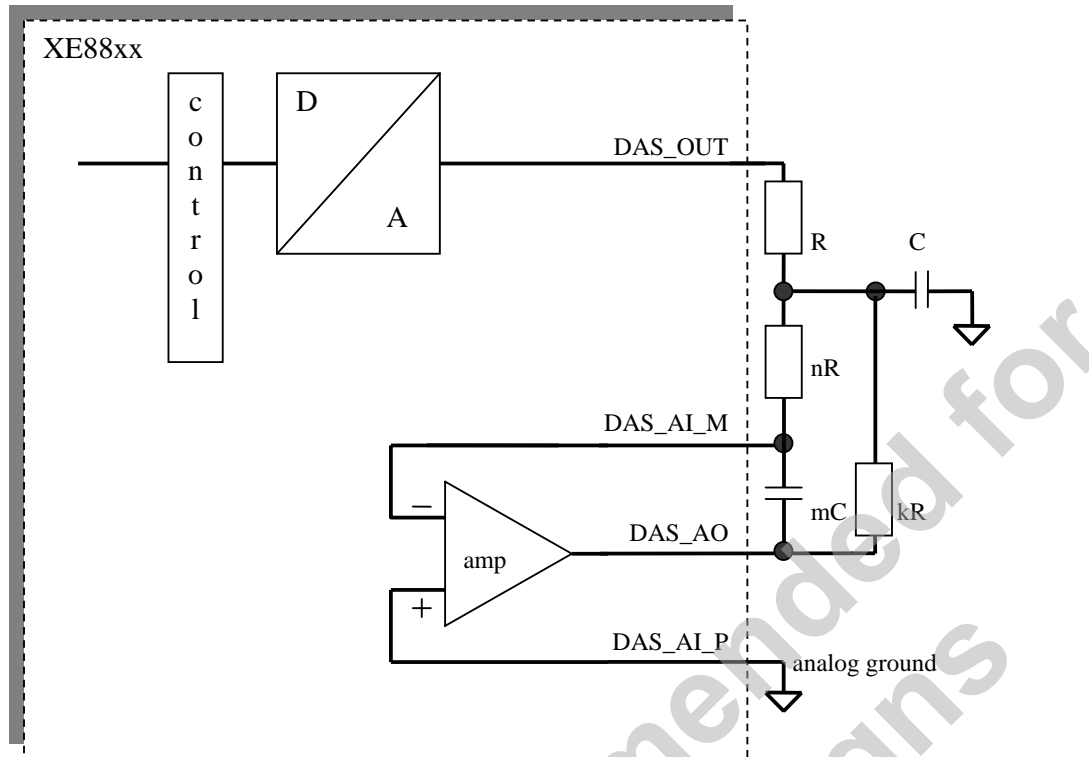

Figure 18-3. Second order low pass filter.

18.7 4-20mA loop

18.7.1 2-wire loop with first order filtering

The amplifier can be used to build a 4-20mA loop externally. Figure 18-4 shows the principle of such a 2-wire loop using a first order low pass filter.

In a 2-wire loop, the current consumption of the sensor and read-out electronics is drawn on the same wires as the signal current. The current consumption of the sensor and read-out electronics should therefore remain below 4mA. The signal current is then added by the bipolar transistor. The resistors R_{lim1} and R_{lim2} are added to protect the bipolar transistor against high transient currents during power-up. R_{lim1} is generally set to a few k Ω . The value of R_{lim2} is chosen as a function of the external loop voltage V_{EXT} and the transistor saturation voltage V_{CEsat} .

$$R_{lim2} = (V_{EXT} - V_{CEsat} - R_{sense} \cdot 20mA) / 20mA$$

If V_{EXT} is larger than 5.5V, a voltage regulator has to be inserted. Since the quiescent current of the regulator adds up to the 4mA budget, a component with sufficiently low quiescent current has to be selected.

The resistor R_{sense} measures the total current in the loop (if $R_{sense} \ll R_{f2}$). The resistors R_{f1} and R_{f2} are used to set the gain and R_{f2} and C_f to set the bandwidth of the filter. The resistor R_{offset} adds an offset to the filter voltage so that the code 0 of the D/A corresponds to 4mA. The amplifier will force a current through the bipolar transistor so that the voltage on the filter V_f and VSS on R_{sense} is equal. This transforms the filter voltage into a loop current $I_{loop} = (VSS - V_{EXT}) / R_{sense}$.

The resistor value R_{sense} is generally chosen between 50Ω and 150Ω resulting in a 1V to 3V voltage drop at maximal loop current. The resistor R_{f2} is then chosen much larger depending on the current error requirement. Allowing for an error of 0.1% gives $R_{f2}=R_{sense}/0.001$.

The resistor R_{offset} may be omitted but it will reduce the useful code range of the D/A.

Using the large bandwidth of the amplifier is recommended since this increases the rejection of supply current variations of the other components in the loop. A bypass capacitor between VBAT and VSS will also reduce the high frequency current variations. Values will depend on the voltage regulator used. The software in the XE8805 should keep the current supply of the circuit as stable as possible. This means that the clock frequency should be kept constant, peripherals should not be switched on and off, the current in the sensor is kept constant, the processor should not use the halt or sleep modes, etc.

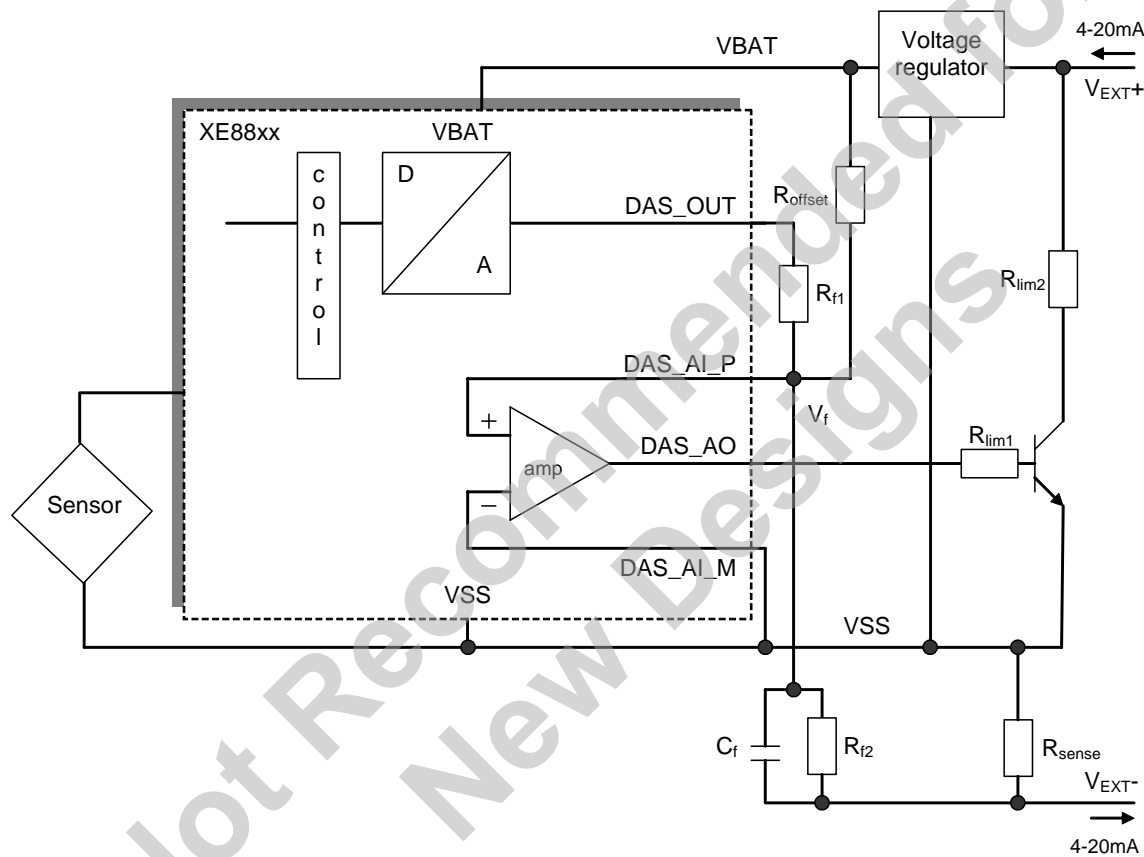

Figure 18-4. 2-wire 4-20mA loop with first order filter

The resistor R_{f1} can then be calculated to set the full scale D/A code range (depends on the PWM modulation m , see section 18.4.3.2) equal to the full scale signal current of 16mA:

$$R_{f1} \leq \frac{(VBAT - VSS) \cdot (2^m - 1) \cdot R_{f2}}{2^m \cdot R_{sense} \cdot 16mA}$$

The resistor R_{offset} can be calculated in order to obtain a 4mA current while the D/A code is 0:

$$R_{offset} \leq \frac{(VBAT - VSS) \cdot R_{f2}}{R_{sense} \cdot 4mA}$$

The capacitor C_f can be calculated from the first order filter cut-off frequency f_c :

$$C_f = \frac{R_{f1} + R_{f2}}{2\pi f_c R_{f1} R_{f2}}$$

As an example, for $V_{BAT}-V_{SS}=5V$, $m=4$, $R_{sense}=50\Omega$, $V_{EXT}=30V$ and a 1kHz low pass filter, we can use: $R_{lim1}=1k\Omega$, $R_{lim2}=1k\Omega$, $R_{f1}=560k\Omega$, $R_{f2}=100k\Omega$, $R_{offset}=2.4M\Omega$, $C_f=1.8nF$.

18.7.2 2-wire loop with second order filtering

A second order filter function can be implemented by replacing the resistor R_{f1} in Figure 18-4 by another first order filter section as shown in Figure 18-5. The value of $R_{f1a}+R_{f2a}$ has to be chosen the same way as R_{f1} in the first order schematic.

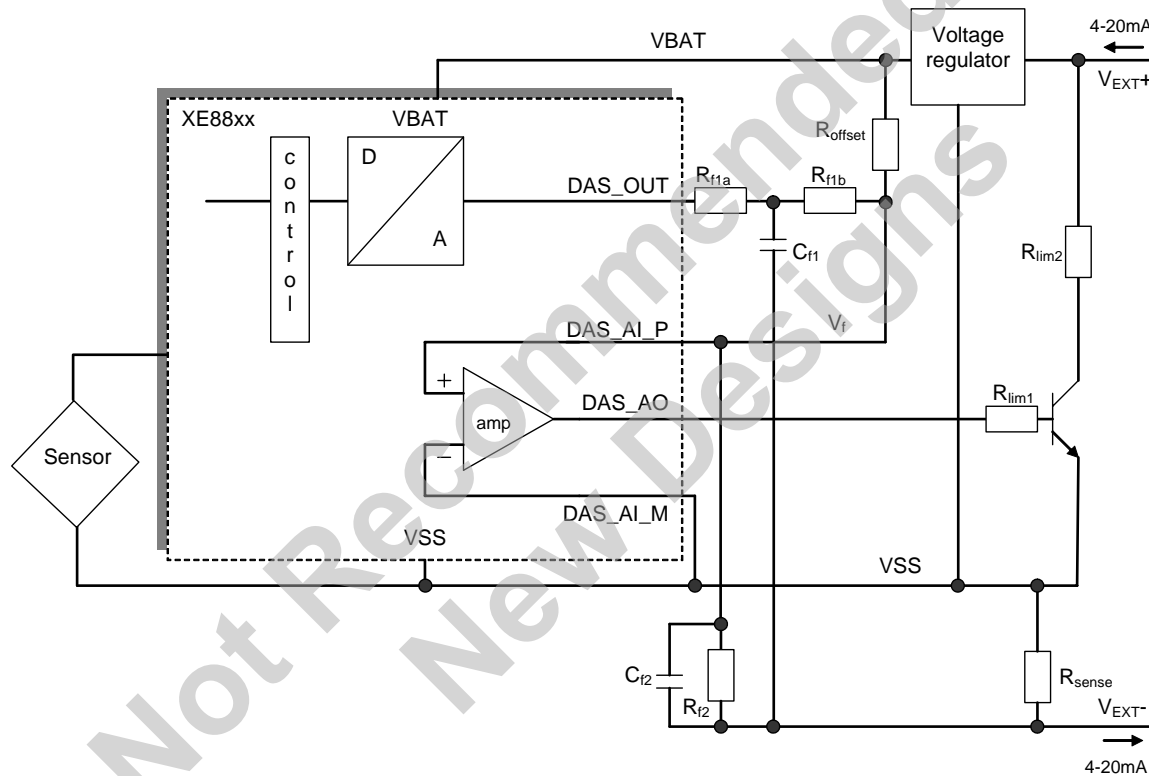

Figure 18-5. 2-wire 4-20mA loop with second order filtering.

Another possibility is shown in Figure 18-6. The advantage this solution is that it is easier to stabilize depending on the component parasitics and board layout. But since it limits the bandwidth of the current regulation loop, it reduces the rejection of the supply current variations.

For this schematic, all the equations of the first order schematic remain valid. The values of R_{fs} and C_{fs} can be calculated from the cut-off frequency:

$$R_{fs} C_{fs} = \frac{1}{2\pi f_c}$$

For the 1kHz example, we can chose $R_{fs}=150k\Omega$ and $C_{fs}=1nF$ (set **BW**=0 in this case).

19. Bias D/A (DAB)

19.1	Features	19-2
19.2	General description	19-2
19.3	Register map	19-2
19.4	D/A specification	19-3
19.5	Amplifier specification	19-3
19.6	Application examples	19-4
19.6.1	Voltage controlled sensor bias	19-4
19.6.2	Current controlled sensor bias	19-4

Not Recommended for
New Designs

19.1 Features

- 8 bit low frequency A/D
- On-chip amplifier with 2 terminals MOS output
- Current and voltage controlled applications can be implemented

19.2 General description

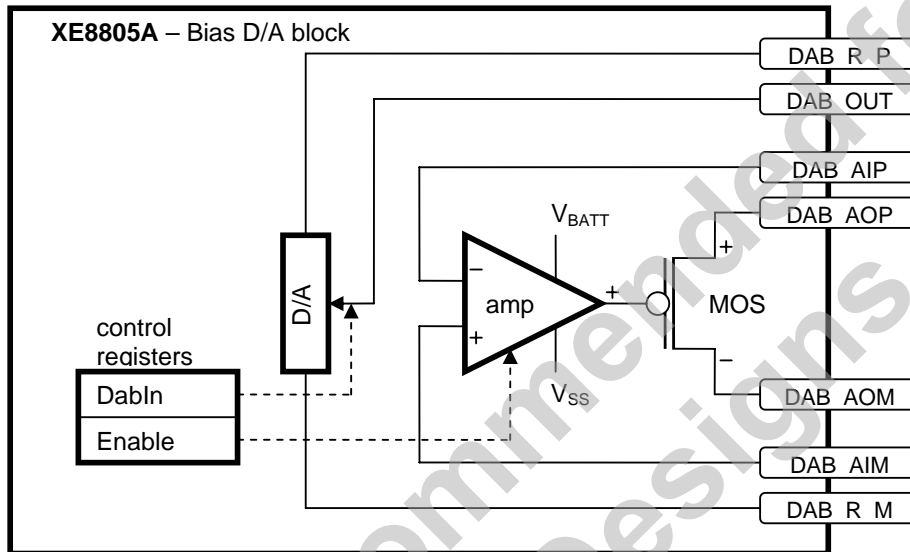

As the amplifier is attacking a MOS, effective polarity of the feedback loop depends on load and network.

Figure 19-1. General block diagram

Figure 19-1 shows the general block diagram of the D/A peripheral. It consists of a control block that manages all communication with the CPU and sets the configuration of the peripheral. The D/A converts the digital data in an analog output signal. An amplifier is added that can be used to drive the large sensor currents.

19.3 Register map

The bias D/A has two registers.

Pos.	RegDabIn	rw	reset	function
7-0	DabIn(7:0)	rw	0 resetsystem	Data to convert

Table 19-1. RegDabIn

Pos.	RegDabCfg	rw	reset	function
7-2		r	0	Unused
1-0	Enable(1:0)	rw	00 resetsystem	bit 1: enables the amplifier when 1 bit 0: enables the D/A when 1

Table 19-2. RegDabCfg

19.4 D/A specification

The D/A generates a voltage on node DAB_OUT that is proportional to the code **RegDabIn** in between the positive reference voltage DAB_R_P and the negative reference voltage DAB_R_M. The voltage on DAB_R_P always has to be larger than the voltage on DAB_R_M. The DAB is intended for very low frequency use. The specification is given in Table 19-3.

The DAB is based on a resistive ladder. Capacitors larger than 100pF are allowed on the node DAB_OUT, but the step response will increase proportionally.

sym	description	min	typ	max	unit	note
wda	number of input bits		8		bits	
tstep	step response		0.25	1	ms	1
OR	D/A output range	DAB_R_M		DAB_R_P		
refp	DAB_R_P range	VSS+2.3		VBAT	V	
refn	DAB_R_M range	VSS		VBAT-2.3	V	
Rdab	impedance between DAB_R_P and DAB_R_M		1.6		Mohm	

1. Time to reach the final value within 5%, C_L on DAB_OUT smaller than 100pF.

Table 19-3. D/A specification.

19.5 Amplifier specification

The amplifier output stage is a single transistor follower that is able to drive large currents. This transistor is not connected internally so that different circuit configurations are possible (see next section). In order to guarantee correct functionality, the voltage on the output pins has to respect the specifications VR_{AOP} and VR_{AOM} as indicated in Table 19-4.

sym	description	min	typ	max	unit	Note
gain	gain at DC	60	90		dB	1
GBW	gain bandwidth product	100	4500		Hz	1
ϕ_m	phase margin	60	80		°	1
R_L	resistive load	300		100000	Ω	
C_L	capacitive load			1	nF	
CMR	common mode input range	VSS		VBAT	V	
VR_{AOM}	DAB_AOM voltage range	VSS+0.2		DAB_AOP-0.2	V	1
VR_{AOP}	DAB_AOP voltage range	VSS+2.3		VBAT	V	1
V_{off}	offset		± 10		mV	
noise	integrated input noise		60	100	μV_{rms}	
I_{source}	max source current	10	40		mA	
PSRR	power supply rejection ratio		80		dB	2
I_{bias}	quiescent bias current		5	10	μA	
I_{off}	off current		0.1	1	μA	

1. For all possible combinations of resistive load and capacitive load.
2. At DC.

Table 19-4. Amplifier specification.

19.6 Application examples

19.6.1 Voltage controlled sensor bias

Figure 19-2 shows the basic connectivity to have a voltage controlled sensor bias. The D/A will generate a voltage between v_{rep} and v_{refn} proportional to the input code. The amplifier will copy the D/A voltage to the sensor. The D/A code can be used to do a software temperature calibration of the sensor for instance.

Filter capacitors can be added in parallel with the sensor reference and signal, on V_{refp} , V_{refn} and DAB_OUT.

The voltages V_{refp} and V_{refn} can be filtered before being connected to the D/A reference inputs. The reference voltages can be connected directly to VBAT and VSS for simplicity. They can also be connected to VBAT and VSS through a low pass filter that rejects the high frequency supply noise. Finally, in most cases, the voltage range of interest for the voltage V_{sensor} on the sensor is only a fraction of the supply voltage. By generating V_{refp} and V_{refn} equal to the limits of the voltage range of interest, the resolution of the D/A can be increased. Example: if a supply of 5V is used and the reference voltage is equal to the supply, the D/A can generate a sensor voltage between 0V and 5V in steps of about $5V/255 \approx 20mV$. If the sensor voltage is always to be between 3V and 4V, and by connecting $V_{refn}=3V$ and $V_{refp}=4V$, the sensor voltage is adjustable between 3V and 4V with steps of about $1V/255 \approx 4mV$.

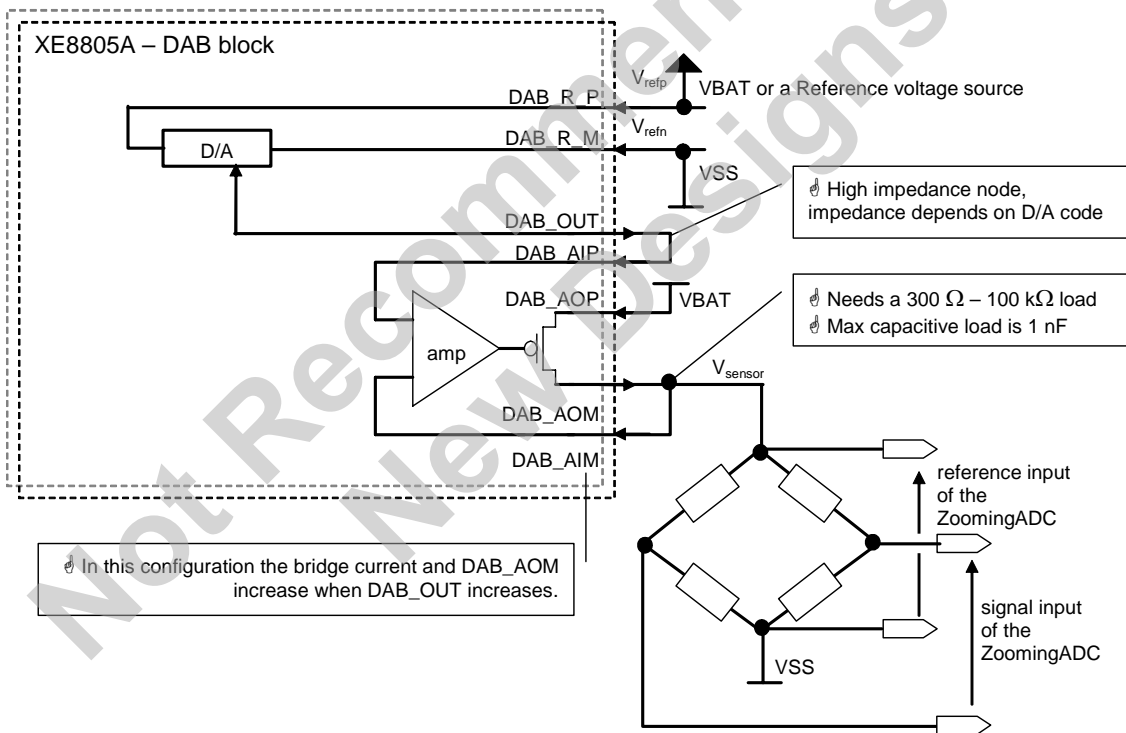

Figure 19-2. Voltage controlled bridge bias principle.

Note that the voltage on the sensor can not be higher than $VBAT-0.2V$ in the example of Figure 19-2 (specification VR_{AOM} in Table 19-4).

19.6.2 Current controlled sensor bias

Figure 19-3 shows the principle of a current controlled sensor bias schematic. In this case, the amplifier forces the voltage V_R to be equal to the D/A output voltage $V_{D/A}$. The current I_{sensor} through the sensor is given by:

$$I_{sensor} = \frac{V_{refp} - V_R}{R_{sense}} = \frac{V_{refp} - V_{D/A}}{R_{sense}} = \frac{(V_{refp} - V_{refn}) \cdot (1 - code/255)}{R_{sense}}$$

The voltage V_{sensor} can be calculated as a function of the current I_{sensor} and the sensor impedance.

Note that the voltage $V_R > VSS + 2.3V$ and $V_R - V_{sensor} > 0.2V$ (VR_{AOP} and VR_{AOM} specifications in Table 19-4) to guarantee correct functionality of this schematic.

Choosing the V_{refp} equal to the supply voltage or close to the supply voltage in order to have the highest possible voltage on the sensor is recommended. From the equation, it can be seen that the sensor current step per LSB can be made smaller by reducing the voltage between V_{refp} and V_{refn} or by increasing the sense resistor value.

As for the voltage controlled sensor bias, capacitors can be added on several nodes to filter out the noise.

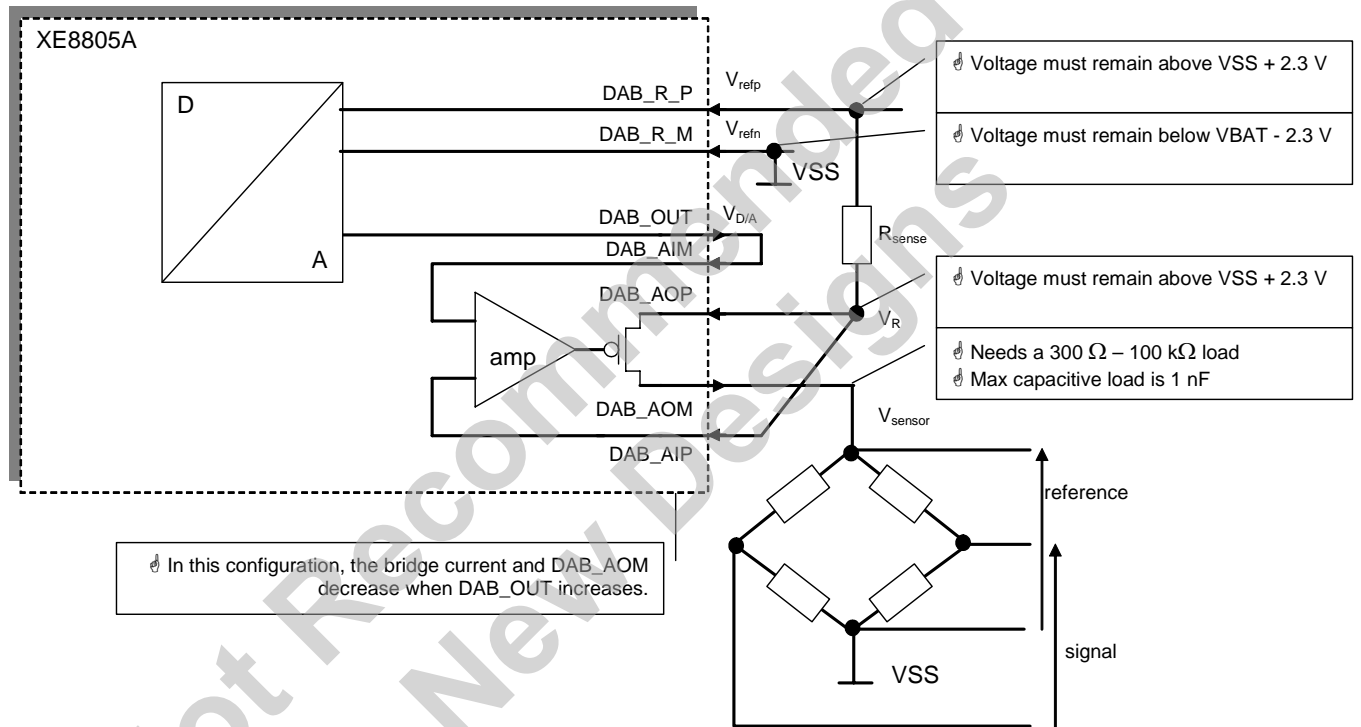

Figure 19-3. Current controlled bridge bias

In Figure 19-4, the sense resistor is inserted between the negative reference voltage and the sensor. This schematic has the same principle as above, but it is easier to respect the limits on VR_{AOP} when $VBAT$ is low. The sensor current is now:

$$I_{sensor} = \frac{V_R - V_{refn}}{R_{sense}} = \frac{V_{D/A} - V_{refn}}{R_{sense}} = \frac{(V_{refp} - V_{refn}) \cdot (code/255)}{R_{sense}}$$

In this case, it is recommended to choose V_{refn} equal to VSS or close to VSS in order to have the highest possible voltage on the sensor. The only limit is now $V_{sensor} < VBAT - 0.2V$.

20. Counters/Timers/PWM

20.1	Features	20-2
20.2	Overview	20-2
20.3	Register map	20-2
20.4	Interrupts and events map	20-3
20.5	Block schematic	20-4
20.6	General counter registers operation	20-4
20.7	Clock selection	20-5
20.8	Counter mode selection	20-5
20.9	Counter / Timer mode	20-6
20.10	PWM mode	20-8
20.11	Capture function	20-9

Not Recommended for
New Designs

20.1 Features

- 4 x 8-bits timer/counter modules or 2 x 16-bits timers/counter modules
- Each with 4 possible clock sources
- Up/down counter modes
- Interrupt and event generation
- Capture function (internal or external source)
- Rising, falling or both edge of capture signal
- PA[3:0] can be used as clock inputs (debounced or direct)
- 2 x 8 bits PWM or 2 x 16 bits PWM
- PWM resolution of 8, 10, 12, 14 or 16 bits
- Complex mode combinations are possible between counter, capture and PWM modes

20.2 Overview

CounterA and CounterB are 8-bit counters and can be combined to form a 16-bit counter. CounterC and CounterD exhibit the same features.

The counters can also be used to generate two PWM outputs on PB[0] and PB[1]. In PWM mode one can generate PWM functions with 8, 10, 12, 14 or 16 bit wide counters.

The counters A and B can be captured by events on an internal or an external signal. The capture can be performed on both 8-bit counters running individually on two different clock sources or on both counters chained to form a 16-bit counter. In any case, the same capture signal is used for both counters.

When the counters A and B are not chained, they can be used in several configurations: A and B as counters, A and B as captured counters, A as PWM and B as counter, A as PWM and B as captured counter.

When the counters C and D are not chained, they can be used either both as counters or counter C as PWM and counter D as counter.

20.3 Register map

Bit	RegCntA	rw	reset	function
7-0	CounterA	r	xxxxxxxx	8-bits counter value
7-0	CounterA	w	xxxxxxxx	8-bits comparison value

Table 20-1. **RegCntA**

bit	RegCntB	rw	reset	function
7-0	CounterB	r	xxxxxxxx	8-bits counter value
7-0	CounterB	w	xxxxxxxx	8-bits comparison value

Table 20-2. **RegCntB**

Note: When writing to **RegCntA** or **RegCntB**, the processor writes the counter comparison values. When reading these locations, the processor reads back either the actual counter value or the last captured value if the capture mode is active.

bit	RegCntC	rw	reset	function
7-0	CounterC	r	xxxxxxxx	8-bits counter value
7-0	CounterC	w	xxxxxxxx	8-bits comparison value

Table 20-3. **RegCntC**

bit	RegCntD	rw	reset	function
7-0	CounterD	r	xxxxxxx	8-bits counter value
7-0	CounterD	w	xxxxxxx	8-bits comparison value

 Table 20-4. **RegCntD**

Note: When writing **RegCntC** or **RegCntD**, the processor writes the counter comparison values. When reading these locations, the processor reads back the actual counter value.

bit	RegCntCtrlCk	rw	reset	function
7-6	CntDCkSel(1:0)	rw	xx	Counter d clock selection
5-4	CntCkSel(1:0)	rw	xx	Counter c clock selection
3-2	CntBCkSel(1:0)	rw	xx	Counter b clock selection
1-0	CntACkSel(1:0)	rw	xx	Counter a clock selection

 Table 20-5. **RegCntCtrlCk**

bit	RegCntConfig1	rw	Reset	function
7	CntDDownUp	rw	x	Counter d up or down counting (0=down)
6	CntCDownUp	rw	x	Counter c up or down counting (0=down)
5	CntBDownUp	rw	x	Counter b up or down counting (0=down)
4	CntADownUp	rw	x	Counter a up or down counting (0=down)
3	CascadeCD	rw	x	Cascade counter c & d (1=cascade)
2	CascadeAB	rw	x	Cascade counter a & b (1=cascade)
1	CntPWM1	rw	0 resetsystem	Activate pwm1 on counter c or c+d (PB(1))
0	CntPWM0	rw	0 resetsystem	Activate pwm0 on counter a or a+b (PB(0))

 Table 20-6. **RegCntConfig1**

bit	RegCntConfig2	rw	Reset	function
7-6	CapSel(1:0)	rw	00 resetsystem	Capture source selection
5-4	CapFunc(1:0)	rw	00 resetsystem	Capture function
3-2	Pwm1Size(1:0)	rw	xx	Pwm1 size selection
1-0	Pwm0Size(1:0)	rw	xx	Pwm0 size selection

 Table 20-7. **RegCntConfig2**

bit	RegCntOn	rw	Reset	Function
7-4	--	r	0000	Reserved
3	CntDEnable	rw	0 resetsystem	Enable counter d
2	CntCEnable	rw	0 resetsystem	Enable counter c
1	CntBEnable	rw	0 resetsystem	Enable counter b
0	CntAEnable	rw	0 resetsystem	Enable counter a

 Table 20-8. **RegCntOn**

20.4 Interrupts and events map

Interrupt source	Mapping in the interrupt manager	Mapping in the event manager
IrqA	RegIrqHigh(4)	RegEvN(7)
IrqB	RegIrqLow(5)	RegEvN(3)
IrqC	RegIrqHigh(3)	RegEvN(6)
IrqD	RegIrqLow(4)	RegEvN(2)

Table 20-9. Interrupt and event mapping.

20.5 Block schematic

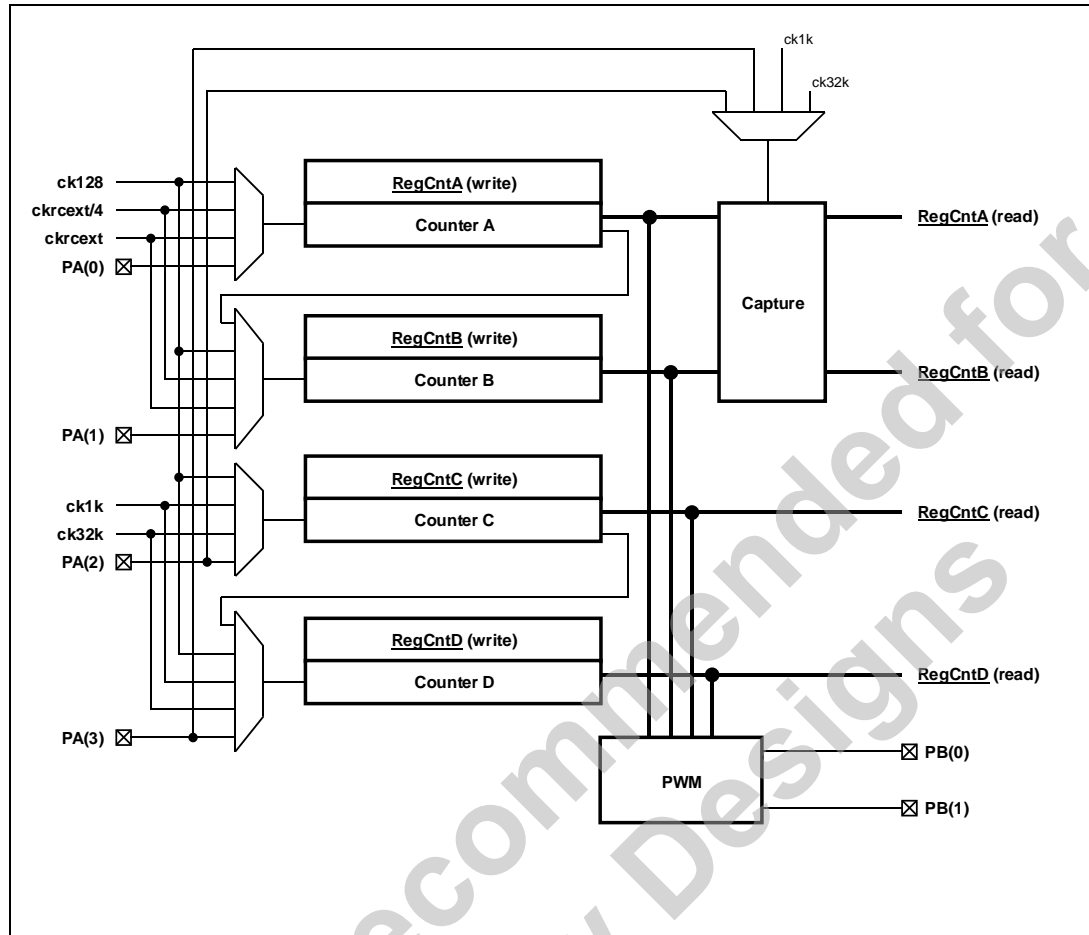

Figure 20-1: Counters/timers block schematic

20.6 General counter registers operation

Counters are enabled by **CntAEnable**, **CntBEnable**, **CntCEnable**, and **CntDEnable** in **RegCntOn**.

To stop the counter X, **CntXEnable** must be reset. To start the counter X, **CntXEnable** must be set. When counters are cascaded, **CntAEnable** and **CntCEnable** also control respectively the counters B and D.

In the control registers, all registers must be written in this order: **RegCntCtrlCk**, **RegCntConfig1**, **RegCntConfig2** and all **RegCntX** because several bits have no default values at reset.

All counters have a corresponding 8-bit read/write register: **RegCntA**, **RegCntB**, **RegCntC**, and **RegCntD**. When read, these registers contain the counter value (or the captured counter value). When written, they modify the counter comparison values.

For a correct acquisition of the counter value, use one of the three following methods:

- 1) Stop the concerned counter, perform the read operation and restart the counter. While stopped, the counter content is frozen and the counter does not take into account the clock edges delivered on the external pin.

- 2) For slow operating counters (typically at least 8 times slower than the CPU clock), oversample the counter content and perform a majority operation on the consecutive read results to select the correct actual content of the counter.
- 3) Use the capture mechanism.

When a value is written into the counter register while the counter is in counter mode, both the comparison value is updated and the counter value is modified. In upcount mode, the register value is reset to zero. In downcount mode, the comparison value is loaded into the counter. Due to the synchronization mechanism between the processor clock domain and the external clock source domain, this modification of the counter value can be postponed until the counter is enabled and it receives it's first valid clock edge.

In the PWM mode, the counter value is not modified by the write operation in the counter register. Changing the counter mode, does not update the counter value (no load in downcount mode).

20.7 Clock selection

The clock source for each counter can be individually selected by writing the appropriate value in the register **RegCntCtrlCk**.

Table 20-10 gives the correspondence between the binary codes used for the configuration bits **CntACkSel(1:0)**, **CntBCkSel(1:0)**, **CntCCkSel(1:0)** or **CntDCkSel(1:0)** and the clock source selected respectively for the counters A, B, C or D.

CntXCkSel(1:0)	Clock source for			
	CounterA	CounterB	CounterC	CounterD
11	Ck128			
10	CkRc/4		Ck1k	
01	CkRc		Ck32k	
00	PA(0)	PA(1)	PA(2)	PA(3)

Table 20-10: Clock sources for counters A, B, C and D

The CkRc clock is the RC oscillator. The clocks below 32kHz can be derived from the RC oscillator or the crystal oscillator (see the documentation of the clock block). A separate external clock source can be delivered on Port A for each individual counter.

The external clock sources can be debounced or not by setting the Port A configuration registers.

The clock source can be changed only when the counter is stopped.

20.8 Counter mode selection

Each counter can work in one of the following modes:

- 1) Counter, downcount & upcount
- 2) Captured counter, downcount & upcount (only counters A&B)
- 3) PWM, downcount

The counters A and B or C and D can be cascaded or not. In cascaded mode, A and C are the LSB counters while B and D are the MSB counters.

Table 20-11 shows the different operation modes of the counters A and B as a function of the mode control bits. For all counter modes, the source of the down or upcount selection is given (either the bit **CntADownUp** or the bit **CntBDownUp**). Also, the mapping of the interrupt sources IrqA and IrqB and the PWM output on PB(0) in these different modes is shown.

CascadeAB CountPWM0 CapFunc(1:0)			Counter A mode	Counter B mode	IrqA source	IrqB source	PB(0) function
0	0	00	Counter 8b Downup: A	Counter 8b Downup: B	Counter A	Counter B	PB(0)
1	0	00	Counter 16b AB Downup: A		Counter AB	-	PB(0)
0	1	00	PWM 8b Down	Counter 8b Down	-	Counter B	PWM A
1	1	00	PWM 10 – 16b AB Down		-	-	PWM AB
0	0	1x or x1	Captured counter 8b Downup: A	Captured counter 8b Downup: B	Capture A	Capture B	PB(0)
1	0	1x or x1	Captured counter 16b AB Downup: A		Capture AB	Capture AB	PB(0)
0	1	1x or x1	PWM 8b Down	Captured counter 8b Downup: B	Must not be used	Capture B	PWM A

Table 20-11: Operating modes of the counters A and B

Table 20-12 shows the different operation modes of the counters C and D as a function of the mode control bits. For all counter modes, the source of the down or upcount selection is given (either the bit **CntCDownUp** or the bit **CntDDownUp**). The mapping of the interrupt sources IrqC and IrqD and the PWM output on PB(1) in these different modes is also shown.

The switching between different modes must be done while the concerned counters are stopped. While switching capture mode on and off, unwanted interrupts can appear on the interrupt channels concerned by this mode change.

CascadeCD	CountPWM1	Counter C mode	Counter D mode	IrqC Source	IrqD source	PB(1) function
0	0	Counter 8b Downup: C	Counter 8b Downup: D	Counter C	Counter D	PB(1)
1	0	Counter 16b CD Downup: C		Counter CD	-	PB(1)
0	1	PWM 8b Down	Counter 8b Down	-	Counter D	PWM C
1	1	PWM 10 – 16b CD Down		-	-	PWM CD

Table 20-12: Operating modes of the counters C and D

20.9 Counter / Timer mode

The counters in counter / timer mode are generally used to generate interrupts after a predefined number of clock periods applied on the counter clock input.

Each counter can be set individually either in upcount mode by setting **CntXDownUp** in the register **RegCntConfig1** or in downcount mode by resetting this bit. Counters A and B can be cascaded to behave as a 16 bit counter by setting **CascadeAB** in the **RegCntConfig1** register. Counters C and D can be cascaded by setting **CascadeCD**. When cascaded, the up/down count modes of the counters B and D are defined respectively by the up/down count modes set for the counters A and C.

When in upcount mode, the counter will start incrementing from zero up to the target value which has been written in the corresponding **ReqCntX** register(s). When the counter content is equal to the target value, an interrupt is generated at the next falling edge of counter clock. Then the counter is loaded again with the zero value at the next rising edge of counter clock (Figure 20-2).

When in downcount mode, the counter will start decrementing from the initial load value which has been written in the corresponding **ReqCntX** register(s) down to the zero value. Once the counter content is equal to zero, an interrupt is generated at the next falling edge of counter clock. Then the counter is loaded again with the load value at the next rising edge of counter clock (Figure 20-2).

Be careful to select the counter mode (no capture, not PWM, specify cascaded or not and up or down counting mode) before writing any target or load value to the **ReqCntX** register(s). This ensures that the counter will start from the correct initial value. When counters are cascaded, both counter registers must be written to ensure that both cascaded counters will start from the correct initial values.

The stopping and consecutive starting of a counter in counter mode without a target or load value write operation in between can generate an interrupt if this counter has been stopped at the zero value (downcount) or at it's target value (upcount). This interrupt is additional to the interrupt which has already been generated when the counter reached the zero or the target value.

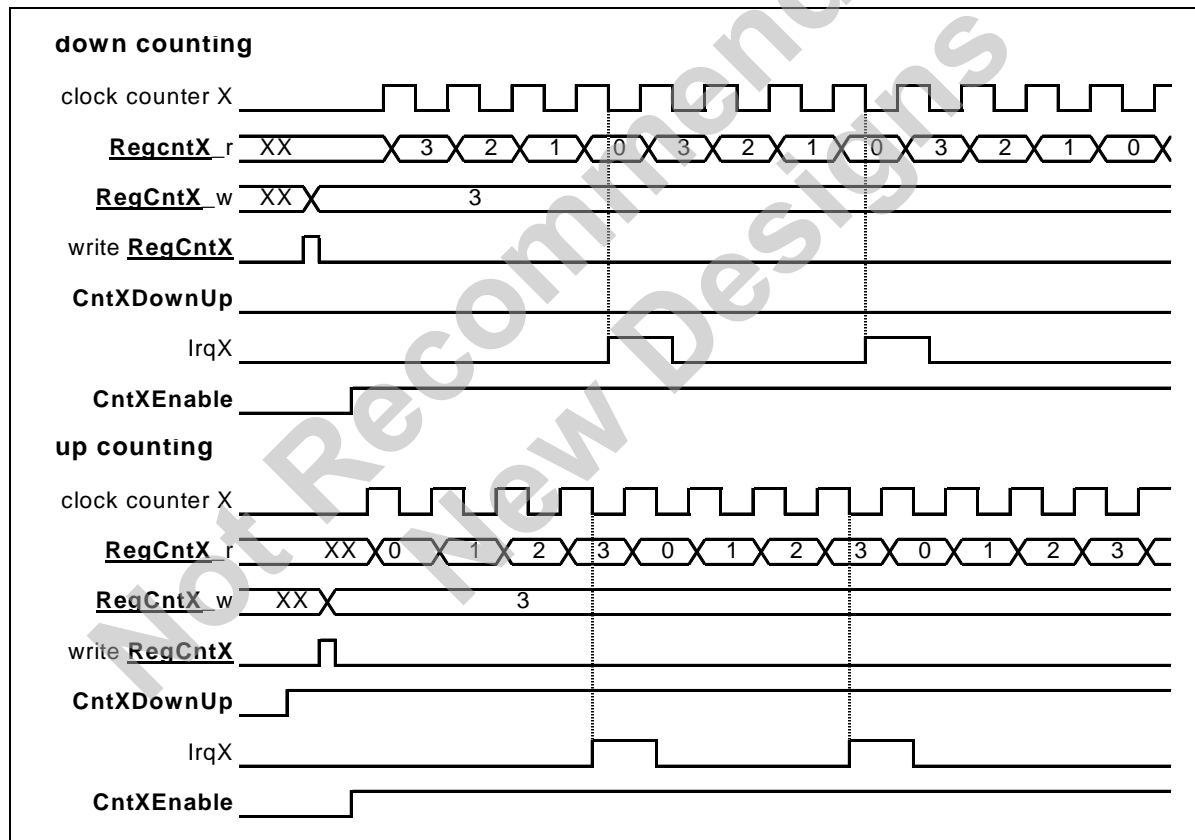

Figure 20-2. Up and down count interrupt generation.

20.10 PWM mode

The counters can generate PWM signals (Pulse Width Modulation) on the Port B outputs PB(0) and PB(1).

The PWM mode is selected by setting **CntPWM1** and **CntPWM0** in the **RegCntConfig1** register. See Table 20-11 and Table 20-12 for an exact description of how the setting of **CntPWM1** and **CntPWM0** affects the operating mode of the counters A, B, C and D according to the other configuration settings.

When **CntPWM0** is enabled, the PWMA or PWMAB output value overrides the value set in bit 0 of **RegPBOut** in the Port B peripheral. When **CntPWM1** is enabled, the PWMC or PWMCD output value overrides the value set in bit 1 of **RegPBOut**. The corresponding ports (0 and/or 1) of Port B must be set in digital mode and as output and either open drain or not and pull up or not through a proper setting of the control registers of the Port B.

Counters in PWM mode always count down, the **CntXDownUp** bit setting must be reset. No interrupts and events are generated by the counters which are in PWM mode. Counters do count circularly: they restart at the maximal value (either 0xFF when not cascaded or 0xFFFF when cascaded) when respectively an underflow condition occurs in the counting.

The internal PWM signals are low as long as the counter contents are higher than the PWM code values written in the **RegCntX** registers. They are high when the counter contents are smaller or equal to these PWM code values.

The PWM resolution is always 8 bits when the counters used for the PWM signal generation are not cascaded. **PWM0Size(1:0)** and **PWM1Size(1:0)** in the **RegCntConfig2** register are used to set the PWM resolution for the counters A and B or C and D respectively when they are in cascaded mode. The different possible resolutions in cascaded mode are shown in Table 20-13. Choosing a 16 bit PWM code higher than the maximum value that can be represented by the number of bits chosen for the resolution, results in a PWM output which is always tied to 1.

PwmXsize(1:0)	Resolution
11	16 bits
10	14 bits
01	12 bits
00	10 bits

Table 20-13: Resolution selection in cascaded PWM mode

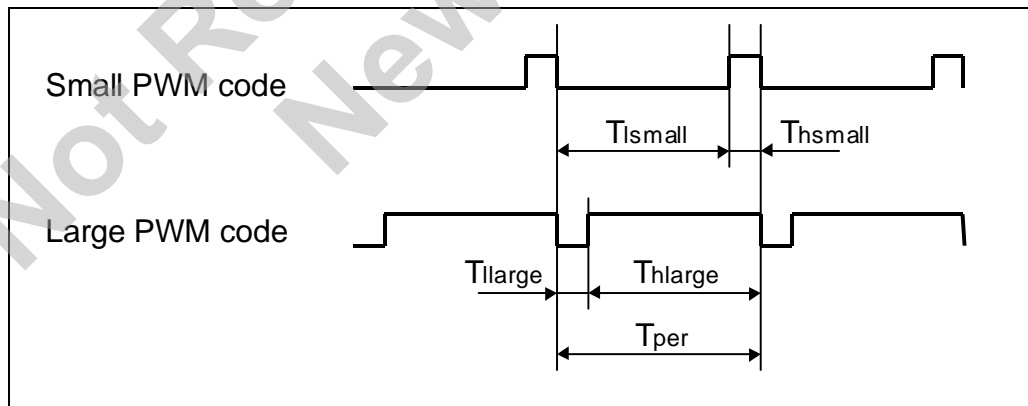

Figure 20-3: PWM modulation examples

The period of the PWM signal is given by the formula:

$$T_{per} = \frac{2^{resolution}}{f_{cknt}}$$

The duty cycle ratio DCR of the PWM signal is defined as:

$$DCR = \frac{T_h}{T_{per}}$$

DCR can be selected between 0 % and $\frac{2^{resolution} - 1}{2^{resolution}} * 100$ %.

DCR in % in function of the RegCntX content(s) is given by the relation:

$$DCR = \frac{100 * \text{RegCntX}}{2^{resolution}}$$

20.11 Capture function

The 16-bit capture register is provided to facilitate frequency measurements. It provides a safe reading mechanism for the counters A and B when they are running. When the capture function is active, the processor does not read anymore the counters A and B directly, but instead reads shadow registers located in the capture block. An interrupt is generated after a capture condition has been met when the shadow register content is updated. The capture condition is user defined by selecting either internal capture signal sources derived from the prescaler or from the external PA(2) or PA(3) ports. Both counters use the same capture condition.

When the capture function is active, the A and B counters must be written with the value 0xFF and can either upcount or downcount. They do count circularly: they restart at zero or at the maximal value (either 0xFF when not cascaded or 0xFFFF when cascaded) when respectively an overflow or an underflow condition occurs in the counting.

CapFunc(1:0) in register **RegCntConfig2** determines if the capture function is enabled or not and selects which edges of the capture signal source are valid for the capture operation. The source of the capture signal can be selected by setting **CapSel(1:0)** in the **RegCntConfig2** register. For all sources, rising, falling or both edge sensitivity can be selected. Table 20-14 shows the capture condition as a function of the setting of these configuration bits.

CapSel(1:0)	Selected capture signal	CapFunc	Selected condition	Capture condition
11	1 K	00	Capture disabled	-
		01	Rising edge	1 K rising edge
		10	Falling edge	1 K falling edge
		11	Both edges	1 K both edges
10	32 K	00	Capture disabled	-
		01	Rising edge	32 K rising edge
		10	Falling edge	32 K falling edge
		11	Both edges	32 K both edges
01	PA3	00	Capture disabled	-
		01	Rising edge	PA3 rising edge
		10	Falling edge	PA3 falling edge
		11	Both edges	PA3 both edges
00	PA2	00	Capture disabled	-
		01	Rising edge	PA2 rising edge
		10	Falling edge	PA2 falling edge
		11	Both edges	PA2 both edges

Table 20-14: Capture condition selection

CapFunc(1:0) and **CapSel(1:0)** can be modified only when the counters are stopped otherwise data may be corrupted during one counter clock cycle.

Due to the synchronization mechanism of the shadow registers and depending on the frequency ratio between the capture and counter clocks, the interrupts may be generated one or only two counter clock pulses after the effective capture condition occurred. When the counters A and B are not cascaded and do not operate on the

same clock, the interruptions on IrqA and IrqB which inform that the capture condition was met, may appear at different moments. In this case, the processor should read the shadow register associated to a counter only if the interruption related to this counter has been detected.

It must be noted that when counters A and B are cascaded, the capture might happen at different cycles for the A and B registers. This is due to the asynchronous relationship between counter and capture clock and to the fact that the capture condition detection is independent for A and B counters.

Not Recommended for
New Designs

21 VLD (Voltage Level Detector)

21.1	Features	21-2
21.2	Overview	21-2
21.3	Register map	21-2
21.4	Interrupt map	21-2
21.5	VLD operation	21-2

Not Recommended for
New Designs

21.1 Features

- Can be switched off, on or simultaneously with CPU activities
- Generates an interrupt if power supply is below a pre-determined level

21.2 Overview

The Voltage Level Detector monitors the state of the system battery. It returns a logical high value (an interrupt) in the status register if the supplied voltage drops below the user defined level (Vsb).

21.3 Register map

There are two registers in the VLD, namely **RegVldCtrl** and **RegVldStat**. Table 221-1 shows the mapping of control bits and functionality of **RegVldCtrl** while Table 221-2 describes that for **RegVldStat**.

pos.	RegVldCtrl	rw	reset	function
7-4	--	r	0000	reserved
3	VldRange	r w	0 resetsystem	VLD detection voltage range for VldTune = "011": 0 : 1.3V 1 : 2.55V
2-0	VldTune[2:0]	r w	000 resetsystem	VLD tuning: 000 : +19 % 111 : -18 %

Table 221-1: **RegVldCtrl**

pos.	RegVldStat	rw	reset	function
7-3	--	r	00000	reserved
2	VldResult	r	0 resetsystem	is 1 when battery voltage is below the detection voltage
1	VldValid	r	0 resetsystem	Indicates when VldResult can be read
0	VldEn	r w	0 resetsystem	VLD enable

Table 221-2: **RegVldStat**

21.4 Interrupt map

interrupt source	mapping in the interrupt manager
IrqVld	RegIrqMid(2)

Table 221-3: **Interrupt map**

21.5 VLD operation

The VLD is controlled by **VldRange**, **VldTune** and **VldEn**. **VldRange** selects the voltage range to be detected, while **VldTune** is used to fine-tune this voltage level in 8 steps. **VldEn** is used to enable (disable) the VLD with a 1(0) value respectively.

Disabled, the block will dissipate no power.

symbol	description	min	typ	max	unit	comments	
Vth	Threshold voltage	Note 1			V	trimming values:	
			1.53			VldRange	VldTune
			1.44			0	000
			1.36			0	001
			1.29			0	010
			1.22			0	011
			1.16			0	100
			1.11			0	101
			1.06			0	110
			3.06			1	111
			2.88			1	000
			2.72			1	001
			2.57			1	010
			2.44			1	011
			2.33			1	100
			2.22			1	101
			2.13			1	110
T _{EOM}	duration of measurement		2.0	2.5	ms	Note 2	
T _{PW}	Minimum pulse width detected		875	1350	us	Note 2	

Table 221-4: Voltage level detector operation

Note 1: absolute precision of the threshold voltage is ±10%.

Note 2: this timing is respected in case the internal RC or crystal oscillators are enabled

To start the voltage level detection, the user sets bit **VldEn**. The measurement is started.

After 2ms, the bit **VldValid** is set to indicate that the measurement results are valid. From that time on, as long as the VLD is enabled, a maskable interrupt request is sent if the voltage level falls below the threshold. One can also poll the VLD and monitor the actual measurement result by reading the **VldResult** bit of the **RegVldStat**. This result is only valid as long as the **VldValid** bit is '1'.

An interrupt is generated on each rising edge of **VldResult**.

22 Physical Dimensions

22.1 QFP type package

22-2

Not Recommended for
New Designs

22.1 QFP type package

The QFP package dimensions are given in Figure 22-1 and Table 22-1. The dimensions conform to JEDEC MS-026 Rev. C.

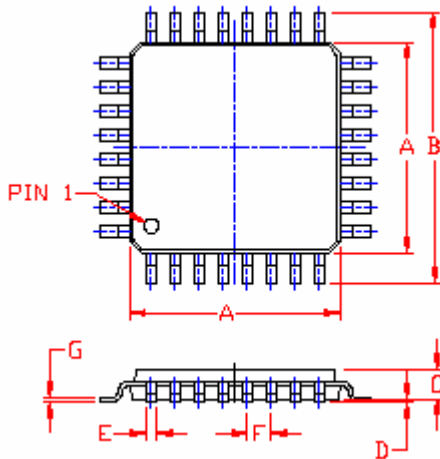

Figure 22-1. QFP type package

package	A	B	C	D	E	F	G
	mm	mm	mm	mm	mm	mm	mm
LQFP-64	10.0	12.0	1.4	0.10	0.22	0.5	

Table 22-1. QFP package dimensions

© Semtech 2005

All rights reserved. Reproduction in whole or in part is prohibited without the prior written consent of the copyright owner. The information presented in this document does not form part of any quotation or contract, is believed to be accurate and reliable and may be changed without notice. No liability will be accepted by the publisher for any consequence of its use. Publication thereof does not convey nor imply any license under patent or other industrial or intellectual property rights. Semtech. assumes no responsibility or liability whatsoever for any failure or unexpected operation resulting from misuse, neglect improper installation, repair or improper handling or unusual physical or electrical stress including, but not limited to, exposure to parameters beyond the specified maximum ratings or operation outside the specified range.

SEMTECH PRODUCTS ARE NOT DESIGNED, INTENDED, AUTHORIZED OR WARRANTED TO BE SUITABLE FOR USE IN LIFE-SUPPORT APPLICATIONS, DEVICES OR SYSTEMS OR OTHER CRITICAL APPLICATIONS. INCLUSION OF SEMTECH PRODUCTS IN SUCH APPLICATIONS IS UNDERSTOOD TO BE UNDERTAKEN SOLELY AT THE CUSTOMER'S OWN RISK. Should a customer purchase or use Semtech products for any such unauthorized application, the customer shall indemnify and hold Semtech and its officers, employees, subsidiaries, affiliates, and distributors harmless against all claims, costs damages and attorney fees which could arise.

Contact Information

Taiwan	Tel: 886-2-2748-3380	Switzerland	Tel: 41-32-729-4000
	Fax: 886-2-2748-3390		Fax: 41-32-729-4001
Korea	Tel: 82-2-527-4377	United Kingdom	Tel: 44-1794-527-600
	Fax: 82-2-527-4376		Fax: 44-1794-527-601
Shanghai	Tel: 86-21-6391-0830	France	Tel: 33-(0)169-28-22-00
	Fax: 86-21-6391-0831		Fax: 33-(0)169-28-12-98
Japan	Tel: 81-3-6408-0950	Germany	Tel: 49-(0)8161-140-123
	Fax: 81-3-6408-0951		Fax: 49-(0)8161-140-124

Semtech International AG is a wholly-owned subsidiary of Semtech Corporation, which has its headquarters in the U.S.A

Looking for pricing, stock, or lifecycle information?

Click below to explore more details on WIN SOURCE:

 [View XE8805AMI028LF on WIN SOURCE](#)

 [Semtech Corporation](#) Information

Optimize Your Supply Chain with WIN SOURCE Solutions

-  Global Sourcing Solution
-  Obsolete Management
-  Cost Control Management
-  Shortage Management
-  Alternative Solution
-  Excess Inventory Management