

TL2575, TL2575HV 1-A Simple Step-Down Switching Voltage Regulators

1 Features

- Fixed 3.3-V, 5-V, 12-V, and 15-V Options with $\pm 5\%$ Regulation (Max) Over Line, Load, and Temperature Conditions
- Adjustable Option With a Range of 1.23 V to 37 V (57 V for HV Version) and $\pm 4\%$ Regulation (Max) Over Line, Load, and Temperature Conditions
- Specified 1-A Output Current
- Wide Input Voltage Range
 - 4.75 V to 40 V (60 V for HV Version)
- Requires Only Four External Components (Fixed Versions) and Uses Readily Available Standard Inductors
- 52-kHz (Typ) Fixed-Frequency Internal Oscillator
- TTL Shutdown Capability With 50- μ A (Typ) Standby Current
- High Efficiency
 - As High as 88% (Typ)
- Thermal Shutdown and Current-Limit Protection with Cycle-by-Cycle Current Limiting

2 Applications

- Simple High-Efficiency Step-Down (Buck) Regulators
- Pre-Regulators for Linear Regulators
- On-Card Switching Regulators
- Positive-to-Negative Converters (Buck-Boost)

4 Functional Block Diagram

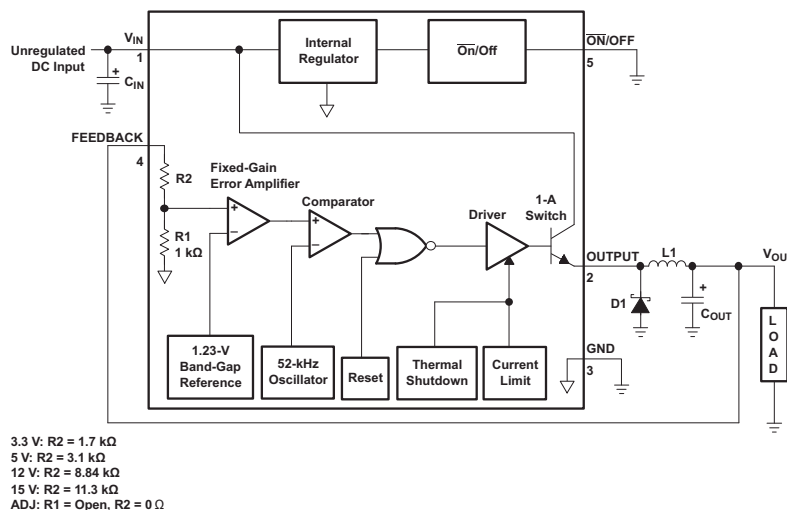

Pin numbers are for the KTT (TO-263) package.

3 Description

The TL2575 and TL2575HV devices provide all the active functions needed for a step-down (buck) switching regulator in an integrated circuit. They require four to six external components for operation. They accept a wide input-voltage range of up to 60 V (TL2575-HV) and are available in fixed output voltages of 3.3 V, 5 V, 12 V, 15 V, or an adjustable-output version. The TL2575 and TL2575HV devices have an integrated switch capable of delivering 1 A of load current, with excellent line and load regulation. The device also offers internal frequency compensation, a fixed-frequency oscillator, cycle-by-cycle current limiting, and thermal shutdown. In addition, a manual shutdown is available via an external $\overline{\text{ON/OFF}}$ pin.

Device Information⁽¹⁾

PART NUMBER	PACKAGE	BODY SIZE (NOM)
TL2575, TL2575HV	PDIP (16)	19.31 mm x 6.35 mm
	TO-263 (5)	10.16 mm x 8.93 mm
	TO-220 (5)	10.16 mm x 8.82 mm

(1) For all available packages, see the orderable addendum at the end of the data sheet.



Table of Contents

1 Features	1	9.1 Overview	11
2 Applications	1	9.2 Functional Block Diagram	11
3 Description	1	9.3 Feature Description	12
4 Functional Block Diagram	1	9.4 Device Functional Modes	12
5 Revision History	2	10 Application and Implementation	13
6 Pin Configuration and Functions	3	10.1 Typical Application	13
7 Specifications	4	11 Power Supply Recommendations	20
7.1 Absolute Maximum Ratings	4	12 Layout	20
7.2 Handling Ratings	4	12.1 Layout Guidelines	20
7.3 Recommended Operating Conditions	4	12.2 Layout Example	20
7.4 Thermal Information	4	13 Device and Documentation Support	21
7.5 Electrical Characteristics — TL2575	5	13.1 Related Links	21
7.6 Electrical Characteristics — TL2575HV	6	13.2 Trademarks	21
7.7 Typical Characteristics	7	13.3 Electrostatic Discharge Caution	21
8 Parameter Measurement Information	10	13.4 Glossary	21
8.1 Test Circuits	10	14 Mechanical, Packaging, and Orderable Information	22
9 Detailed Description	11		

5 Revision History

Changes from Revision B (January 2007) to Revision C

Page

• Updated document to new TI data sheet format	1
• Deleted Ordering Information table	1
• Added Pin Functions table	3
• Added Handling Ratings table	4
• Changed Thermal Information table	4
• Added Detailed Description section	11
• Added Application and Implementation section	13
• Added Power Supply Recommendations and Layout sections	20

6 Pin Configuration and Functions

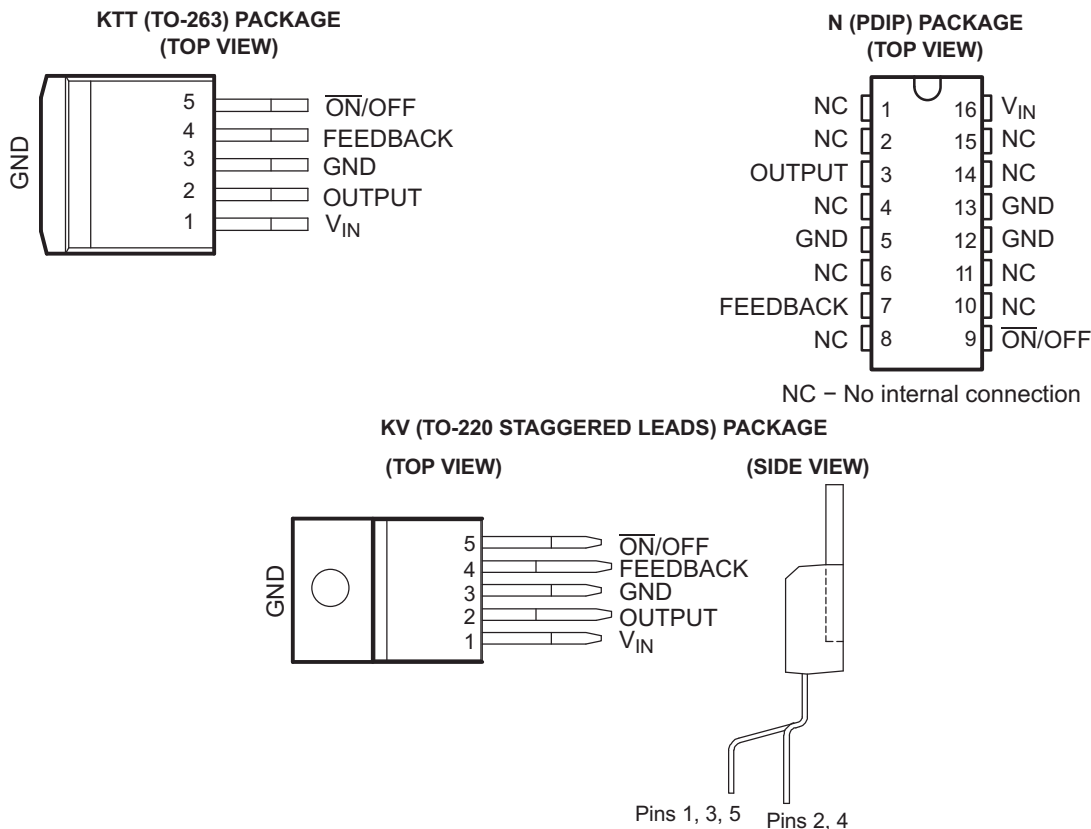

Pin Functions

NAME	PIN			TYPE	DESCRIPTION
	KTT TO-263	N PDIP	KV TO-220		
FEEDBACK	4	7	4	Input	Feedback pin. Connect to V_{OUT} for fixed-voltage TL2575. Connect between two adjustment resistors for adjustable-voltage TL2575.
GND	3	5	3	—	Ground
		12			
		13			
NC	—	1	—	—	No connect
		2			
		4			
		6			
		8			
		10			
		11			
14					
15					
$\overline{ON/OFF}$	5	9	5	Input	Manual shutdown pin
OUTPUT	2	3	2	Output	Output pin
V_{IN}	1	16	1	Input	Supply input pin

7 Specifications

7.1 Absolute Maximum Ratings⁽¹⁾

over operating free-air temperature range (unless otherwise noted)

		MIN	MAX	UNIT
V _{IN}	Supply voltage	TL2575HV	60	V
		TL2575	42	
$\overline{\text{ON/OFF}}$ input voltage range		-0.3	V _{IN}	V
Output voltage to GND (steady state)			-1	V
T _J	Maximum junction temperature		150	°C

(1) Stresses beyond those listed under *Absolute Maximum Ratings* may cause permanent damage to the device. These are stress ratings only, and functional operation of the device at these or any other conditions beyond those indicated under *Recommended Operating Conditions* is not implied. Exposure to absolute-maximum-rated conditions for extended periods may affect device reliability.

7.2 Handling Ratings

		MIN	MAX	UNIT	
T _{stg}	Storage temperature range	-65	150	°C	
V _(ESD)	Electrostatic discharge	Human body model (HBM), per ANSI/ESDA/JEDEC JS-001, all pins ⁽¹⁾	0	2000	V
		Charged device model (CDM), per JEDEC specification JESD22-C101, all pins ⁽²⁾	0	1000	

(1) JEDEC document JEP155 states that 500-V HBM allows safe manufacturing with a standard ESD control process.

(2) JEDEC document JEP157 states that 250-V CDM allows safe manufacturing with a standard ESD control process.

7.3 Recommended Operating Conditions

over operating free-air temperature range (unless otherwise noted)

		MIN	MAX	UNIT	
V _{IN}	Supply voltage	TL2575HV	4.75	60	V
		TL2575	4.75	40	
T _J	Operating virtual junction temperature	-40	125	°C	

7.4 Thermal Information

THERMAL METRIC ⁽¹⁾		KTT	KV	N	UNIT
		5 PINS	5 PINS	16 PINS	
R _{θJA}	Junction-to-ambient thermal resistance	26.5	26.5	67	°C/W
R _{θJC(top)}	Junction-to-case (top) thermal resistance	31.8	31.8	57	
R _{θJC(bot)}	Junction-to-case (bottom) thermal resistance	0.38	0.38	—	

(1) For more information about traditional and new thermal metrics, see the *IC Package Thermal Metrics* application report ([SPRA953](http://www.ti.com/lit/spr9953)).

7.5 Electrical Characteristics — TL2575

$I_{LOAD} = 200\text{ mA}$, $V_{IN} = 12\text{ V}$ for 3.3-V, 5-V, and adjustable versions, $V_{IN} = 25\text{ V}$ for 12-V version, $V_{IN} = 30\text{ V}$ for 15-V version (unless otherwise noted) (see [Figure 11](#))

PARAMETER		TEST CONDITIONS	T_J	TL2575			UNIT
				MIN	TYP	MAX	
V_{OUT}	Output voltage	TL2575-33 $V_{IN} = 12\text{ V}$, $I_{LOAD} = 0.2\text{ A}$	25°C	3.234	3.3	3.366	V
			25°C	3.168	3.3	3.432	
			Full range	3.135		3.465	
		TL2575-05 $V_{IN} = 12\text{ V}$, $I_{LOAD} = 0.2\text{ A}$	25°C	4.9	5	5.1	
			25°C	4.8	5	5.2	
			Full range	4.75		5.25	
	TL2575-12 $V_{IN} = 25\text{ V}$, $I_{LOAD} = 0.2\text{ A}$	25°C	11.76	12	12.24		
		25°C	11.52	12	12.48		
		Full range	11.4		12.6		
	TL2575-15 $V_{IN} = 30\text{ V}$, $I_{LOAD} = 0.2\text{ A}$	25°C	14.7	15	15.3		
		25°C	14.4	15	15.6		
		Full range	14.25		15.75		
Feedback voltage	TL2575-ADJ	$V_{IN} = 12\text{ V}$, $V_{OUT} = 5\text{ V}$, $I_{LOAD} = 0.2\text{ A}$	25°C	1.217	1.23	1.243	V
			25°C	1.193	1.23	1.267	
			Full range	1.18		1.28	
η	Efficiency	TL2575-33 $V_{IN} = 12\text{ V}$, $I_{LOAD} = 1\text{ A}$	25°C	75%			
		TL2575-05 $V_{IN} = 12\text{ V}$, $I_{LOAD} = 1\text{ A}$		77%			
		TL2575-12 $V_{IN} = 15\text{ V}$, $I_{LOAD} = 1\text{ A}$		88%			
		TL2575-15 $V_{IN} = 18\text{ V}$, $I_{LOAD} = 1\text{ A}$		88%			
		TL2575-ADJ $V_{IN} = 12\text{ V}$, $V_{OUT} = 5\text{ V}$, $I_{LOAD} = 1\text{ A}$		77%			
I_{FB}	Feedback bias current	$V_{OUT} = 5\text{ V}$ (ADJ version only)	25°C	50		100	nA
			Full range	500			
f_o	Oscillator frequency ⁽¹⁾		25°C	47	52	58	kHz
			Full range	42		63	
V_{SAT}	Saturation voltage	$I_{OUT} = 1\text{ A}$ ⁽²⁾	25°C	0.9		1.2	V
			Full range	1.4			
	Maximum duty cycle ⁽³⁾		25°C	93%	98%		
I_{CL}	Switch peak current ⁽¹⁾⁽²⁾		25°C	1.7	2.8	3.6	A
			Full range	1.3		4	
I_L	Output leakage current	$V_{IN} = 40$ ⁽⁴⁾ , Output = 0 V	25°C			2	mA
		$V_{IN} = 40$ ⁽⁴⁾ , Output = -1 V		7.5		30	
I_Q	Quiescent current ⁽⁴⁾		25°C	5		10	mA
I_{STBY}	Standby quiescent current	OFF ($\overline{ON}/OFF = 5\text{ V}$)	25°C	50		200	μA

(1) In the event of an output short or an overload condition, self-protection features lower the oscillator frequency to $\approx 18\text{ kHz}$ and the minimum duty cycle from 5% to $\approx 2\%$. The resulting output voltage drops to $\approx 40\%$ of its nominal value, causing the average power dissipated by the IC to lower.

(2) Output is not connected to diode, inductor, or capacitor. Output is sourcing current.

(3) FEEDBACK is disconnected from output and connected to 0 V.

(4) To force the output transistor off, FEEDBACK is disconnected from output and connected to 12 V for the adjustable, 3.3-V, and 5-V versions and to 25 V for the 12-V and 15-V versions.

Electrical Characteristics — TL2575 (continued)
 $I_{LOAD} = 200 \text{ mA}$, $V_{IN} = 12 \text{ V}$ for 3.3-V, 5-V, and adjustable versions, $V_{IN} = 25 \text{ V}$ for 12-V version, $V_{IN} = 30 \text{ V}$ for 15-V version (unless otherwise noted) (see [Figure 11](#))

PARAMETER	TEST CONDITIONS	T_J	TL2575			UNIT
			MIN	TYP	MAX	
V_{IH}	\overline{ON}/OFF high-level logic input voltage	25°C	2.2	1.4		V
		Full range	2.4			
V_{IL}	\overline{ON}/OFF low-level logic input voltage	25°C		1.2	1	V
		Full range			0.8	
I_{IH}	\overline{ON}/OFF high-level input current	25°C		12	30	μA
I_{IL}	\overline{ON}/OFF low-level input current	25°C		0	10	μA

7.6 Electrical Characteristics — TL2575HV
 $I_{LOAD} = 200 \text{ mA}$, $V_{IN} = 12 \text{ V}$ for 3.3-V, 5-V, and adjustable versions, $V_{IN} = 25 \text{ V}$ for 12-V version, $V_{IN} = 30 \text{ V}$ for 15-V version (unless otherwise noted) (see [Figure 11](#))

PARAMETER	TEST CONDITIONS	T_J	TL2575HV			UNIT	
			MIN	TYP	MAX		
V_{OUT}	TL2575HV-33	$V_{IN} = 12 \text{ V}$, $I_{LOAD} = 0.2 \text{ A}$	25°C	3.234	3.3	3.366	V
		$4.75 \text{ V} \leq V_{IN} \leq 60 \text{ V}$, $0.2 \text{ A} \leq I_{LOAD} \leq 1 \text{ A}$	25°C	3.168	3.3	3.450	
			Full range		3.135		
	TL2575HV-05	$V_{IN} = 12 \text{ V}$, $I_{LOAD} = 0.2 \text{ A}$	25°C	4.9	5	5.1	
		$8 \text{ V} \leq V_{IN} \leq 60 \text{ V}$, $0.2 \text{ A} \leq I_{LOAD} \leq 1 \text{ A}$	25°C	4.8	5	5.225	
			Full range		4.75		
	TL2575HV-12	$V_{IN} = 25 \text{ V}$, $I_{LOAD} = 0.2 \text{ A}$	25°C	11.76	12	12.24	
		$15 \text{ V} \leq V_{IN} \leq 60 \text{ V}$, $0.2 \text{ A} \leq I_{LOAD} \leq 1 \text{ A}$	25°C	11.52	12	12.54	
			Full range		11.4		
	TL2575HV-15	$V_{IN} = 30 \text{ V}$, $I_{LOAD} = 0.2 \text{ A}$	25°C	14.7	15	15.3	
		$18 \text{ V} \leq V_{IN} \leq 60 \text{ V}$, $0.2 \text{ A} \leq I_{LOAD} \leq 1 \text{ A}$	25°C	14.4	15	15.68	
			Full range		14.25	15	
Feedback voltage	TL2575HV-ADJ	$V_{IN} = 12 \text{ V}$, $V_{OUT} = 5 \text{ V}$, $I_{LOAD} = 0.2 \text{ A}$	25°C	1.217	1.23	1.243	V
		$8 \text{ V} \leq V_{IN} \leq 60 \text{ V}$, $V_{OUT} = 5 \text{ V}$, $0.2 \text{ A} \leq I_{LOAD} \leq 1 \text{ A}$	25°C	1.193	1.23	1.273	
			Full range		1.180		
η	TL2575HV-33	$V_{IN} = 12 \text{ V}$, $I_{LOAD} = 1 \text{ A}$	25°C		75%		
	TL2575HV-05	$V_{IN} = 12 \text{ V}$, $I_{LOAD} = 1 \text{ A}$			77%		
	TL2575HV-12	$V_{IN} = 15 \text{ V}$, $I_{LOAD} = 1 \text{ A}$			88%		
	TL2575HV-15	$V_{IN} = 18 \text{ V}$, $I_{LOAD} = 1 \text{ A}$			88%		
	TL2575HV-ADJ	$V_{IN} = 12 \text{ V}$, $V_{OUT} = 5 \text{ V}$, $I_{LOAD} = 1 \text{ A}$			77%		
I_{IB}	Feedback bias current	$V_{OUT} = 5 \text{ V}$ (ADJ version only)	25°C		50	100	nA
			Full range			500	
f_o	Oscillator frequency ⁽¹⁾		25°C	47	52	58	kHz
			Full range		42		
V_{SAT}	Saturation voltage	$I_{OUT} = 1 \text{ A}$ ⁽²⁾	25°C		0.9	1.2	V
			Full range			1.4	
	Maximum duty cycle ⁽³⁾		25°C	93%	98%		

(1) In the event of an output short or an overload condition, self-protection features lower the oscillator frequency to $\approx 18 \text{ kHz}$ and the minimum duty cycle from 5% to $\approx 2\%$. The resulting output voltage drops to $\approx 40\%$ of its nominal value, causing the average power dissipated by the IC to lower.

(2) Output is not connected to diode, inductor, or capacitor. Output is sourcing current.

(3) FEEDBACK is disconnected from output and connected to 0 V.

Electrical Characteristics — TL2575HV (continued)

$I_{LOAD} = 200\text{ mA}$, $V_{IN} = 12\text{ V}$ for 3.3-V, 5-V, and adjustable versions, $V_{IN} = 25\text{ V}$ for 12-V version, $V_{IN} = 30\text{ V}$ for 15-V version (unless otherwise noted) (see Figure 11)

PARAMETER	TEST CONDITIONS	T_J	TL2575HV			UNIT
			MIN	TYP	MAX	
I_{CL} Switch peak current ^{(1) (2)}		25°C	1.7	2.8	3.6	A
		Full range	1.3			
I_L Output leakage current	$V_{IN} = 60^{(4)}$, Output = 0 V	25°C				mA
	$V_{IN} = 60^{(4)}$, Output = -1 V		2			
I_Q Quiescent current ⁽⁴⁾		25°C	7.5			30
I_{STBY} Standby quiescent current	OFF ($\overline{ON}/OFF = 5\text{ V}$)	25°C	5			10
V_{IH} \overline{ON}/OFF high-level logic input voltage	OFF ($V_{OUT} = 0\text{ V}$)	25°C	50			200
		Full range	2.2			1.4
V_{IL} \overline{ON}/OFF low-level logic input voltage	ON ($V_{OUT} = \text{nominal voltage}$)	25°C	2.4			V
		Full range	2.4			
I_{IH} \overline{ON}/OFF high-level input current	OFF ($\overline{ON}/OFF = 5\text{ V}$)	25°C	1.2			1
			Full range	0.8		
I_{IL} \overline{ON}/OFF low-level input current	ON ($\overline{ON}/OFF = 0\text{ V}$)	25°C	12			30
			Full range	0		

(4) To force the output transistor off, FEEDBACK is disconnected from output and connected to 12 V for the adjustable, 3.3-V, and 5-V versions and to 25 V for the 12-V and 15-V versions.

7.7 Typical Characteristics

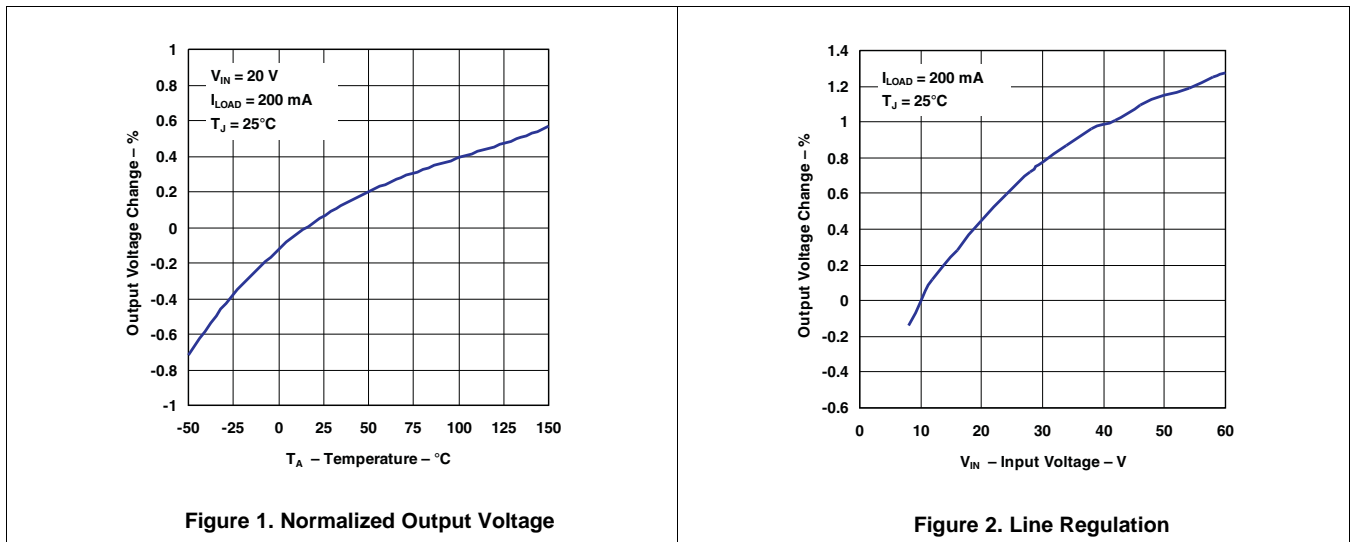

Typical Characteristics (continued)

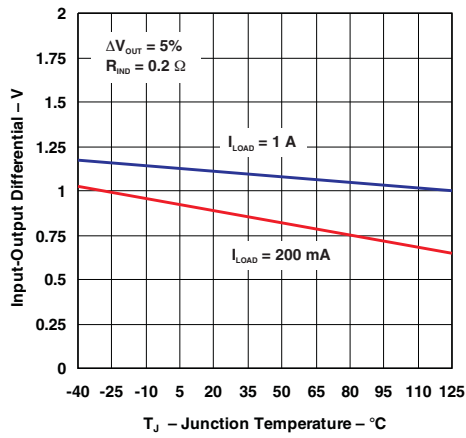

Figure 3. Dropout Voltage

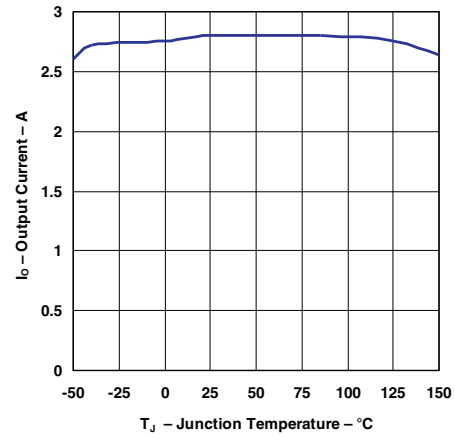

Figure 4. Current Limit

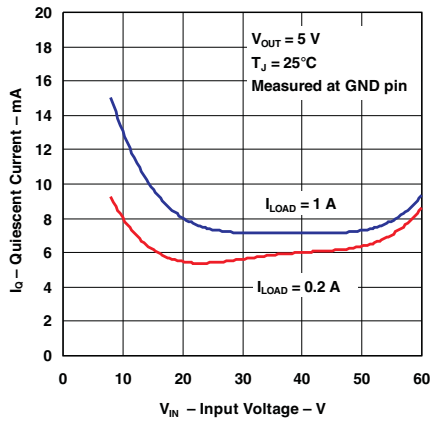

Figure 5. Quiescent Current

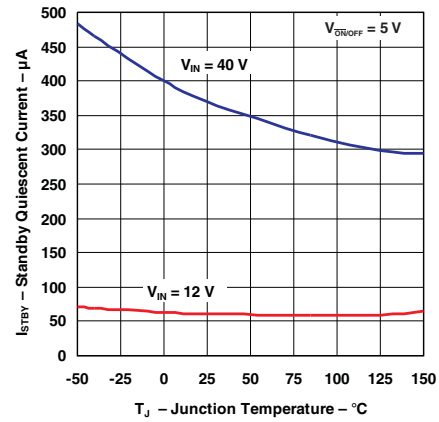

Figure 6. Standby Quiescent Current

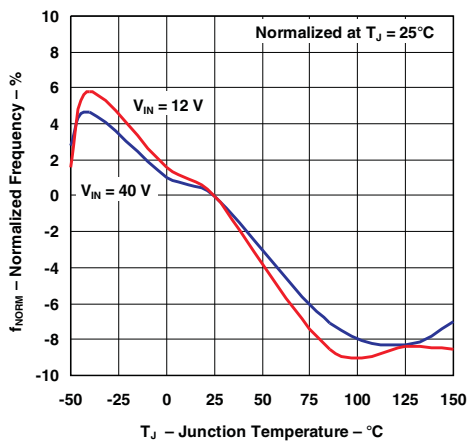

Figure 7. Oscillator Frequency

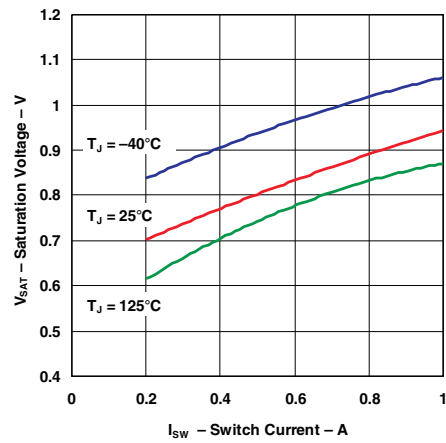

Figure 8. Switch Saturation Voltage

Typical Characteristics (continued)

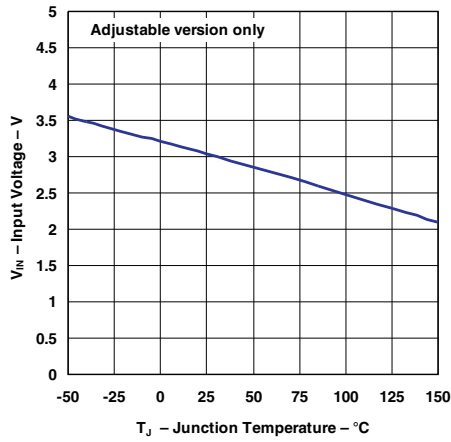

Figure 9. Minimum Operating Voltage

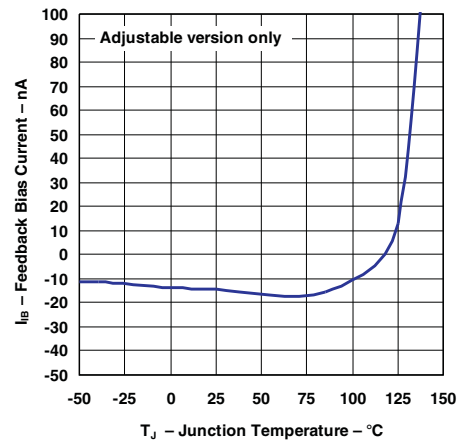
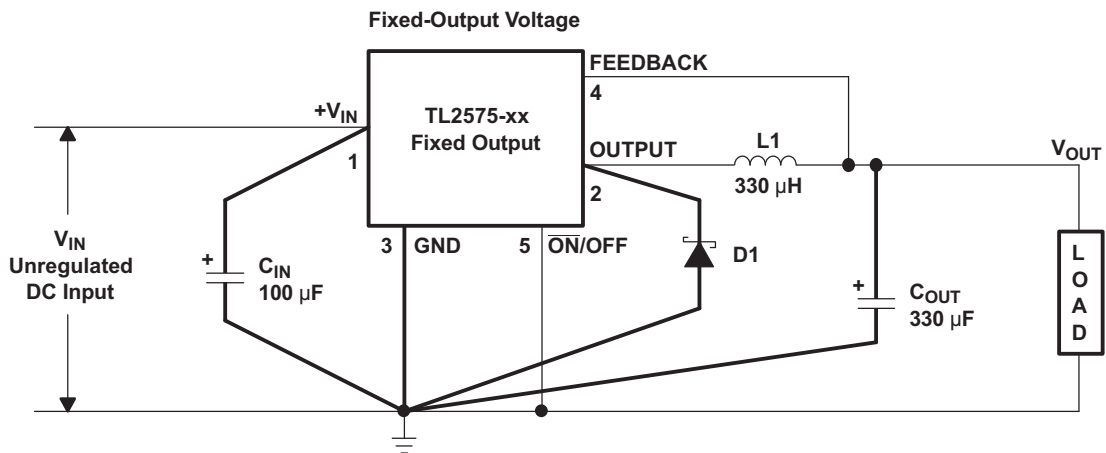

Figure 10. FEEDBACK Current

8 Parameter Measurement Information

8.1 Test Circuits



$C_{IN} = 100 \mu\text{F}$, Aluminum Electrolytic
 $C_{OUT} = 330 \mu\text{F}$, Aluminum Electrolytic
 D1 = Schottky
 $L1 = 330 \mu\text{H}$ (for 5-V V_{IN} with 3.3-V V_{OUT} , use 100 μH)

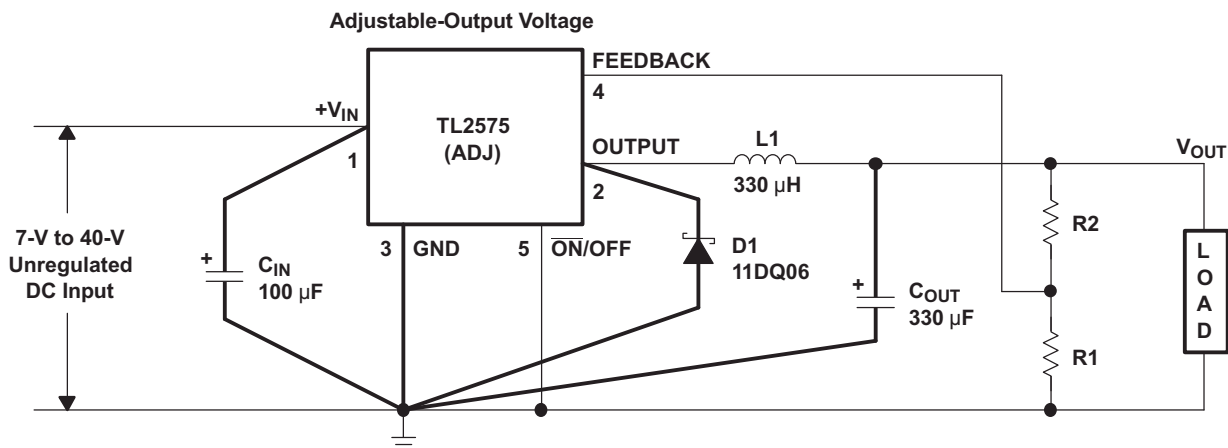

$$V_{OUT} = V_{REF} (1 + R2 / R1) = 5 \text{ V}$$

$V_{REF} = 1.23 \text{ V}$
 $R1 = 2 \text{ k}\Omega$
 $R2 = 6.12 \text{ k}\Omega$

Pin numbers are for the KTT (TO-263) package.

Figure 11. Test Circuits and Layout Guidelines

9 Detailed Description

9.1 Overview

The TL2575 and TL2575HV devices greatly simplify the design of switching power supplies by conveniently providing all the active functions needed for a step-down (buck) switching regulator in an integrated circuit. Accepting a wide input-voltage range of up to 60 V (TL2575-HV) and available in fixed output voltages of 3.3 V, 5 V, 12 V, 15 V, or an adjustable-output version, the TL2575 and TL2575HV devices have an integrated switch capable of delivering 1 A of load current, with excellent line and load regulation. The device also offers internal frequency compensation, a fixed-frequency oscillator, cycle-by-cycle current limiting, and thermal shutdown. In addition, a manual shutdown is available via an external ON/OFF pin.

The TL2575 and TL2575HV devices represent superior alternatives to popular three-terminal linear regulators. Due to their high efficiency, the devices significantly reduce the size of the heatsink and, in many cases, no heatsink is required. Optimized for use with standard series of inductors available from several different manufacturers, the TL2575 and TL2575HV greatly simplify the design of switch-mode power supplies by requiring a minimal addition of only four to six external components for operation.

The TL2575 and TL2575HV devices are characterized for operation over the virtual junction temperature range of -40°C to 125°C .

9.2 Functional Block Diagram

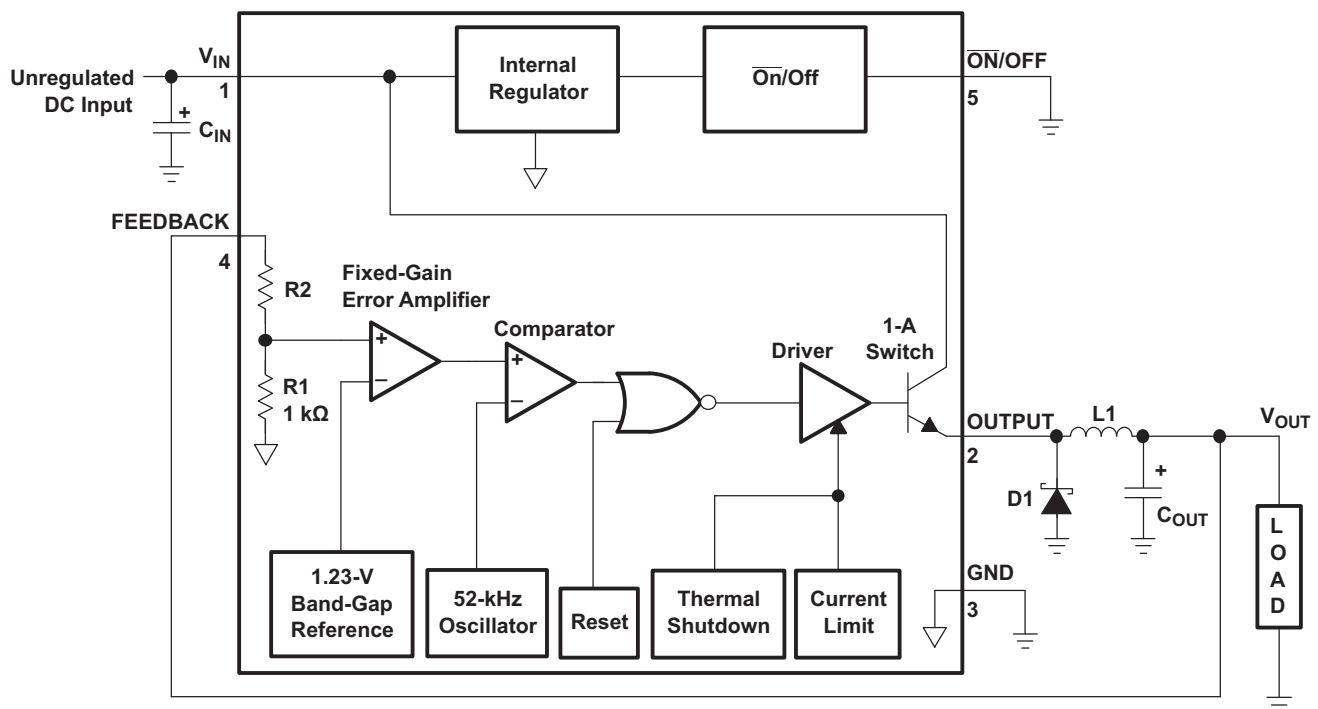

3.3 V: $R2 = 1.7\text{ k}\Omega$
 5 V: $R2 = 3.1\text{ k}\Omega$
 12 V: $R2 = 8.84\text{ k}\Omega$
 15 V: $R2 = 11.3\text{ k}\Omega$
 ADJ: $R1 = \text{Open}$, $R2 = 0\ \Omega$

Pin numbers are for the KTT (TO-263) package.

9.3 Feature Description

9.3.1 Feedback Connection

For fixed-voltage options, FEEDBACK must be wired to V_{OUT} . For the adjustable version, FEEDBACK must be connected between the two programming resistors. Again, both of these resistors should be in close proximity to the regulator, and each should be less than 100 k Ω to minimize noise pickup.

9.3.2 $\overline{ON/OFF}$ Input

$\overline{ON/OFF}$ should be grounded or be a low-level TTL voltage (typically < 1.6 V) for normal operation. To shut down the TL2575 or TL2575HV devices and place in standby mode, a high-level TTL or CMOS voltage should be supplied to this pin. $\overline{ON/OFF}$ should not be left open and safely can be pulled up to V_{IN} with or without a pullup resistor.

9.4 Device Functional Modes

9.4.1 Standby Mode

When a high-level TTL or CMOS voltage is applied to the $\overline{ON/OFF}$ pin, the device enters standby mode, drawing a typical quiescent current of 50 μ A.

10 Application and Implementation

NOTE

Information in the following applications sections is not part of the TI component specification, and TI does not warrant its accuracy or completeness. TI's customers are responsible for determining suitability of components for their purposes. Customers should validate and test their design implementation to confirm system functionality.

10.1 Typical Application

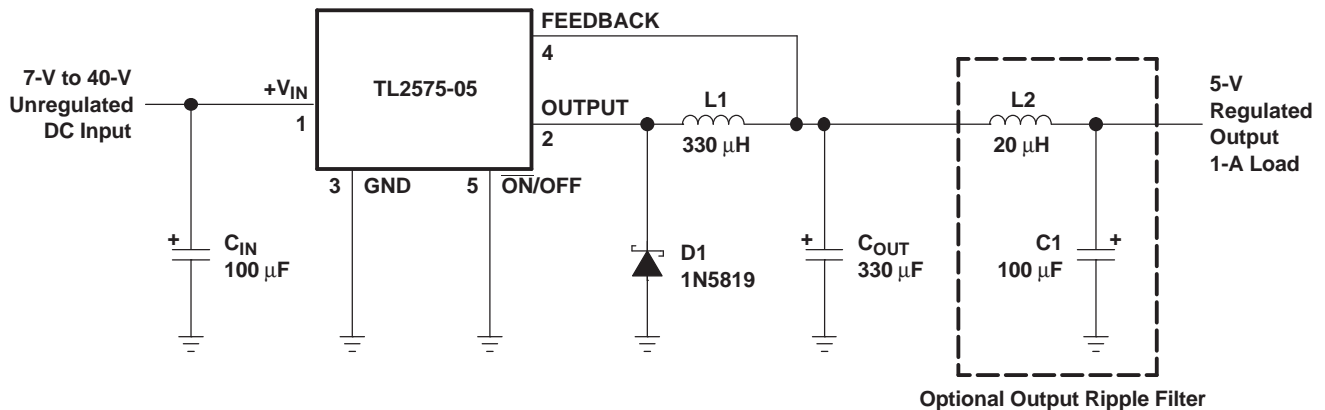

Pin numbers are for the KTT (TO-263) package.

Figure 12. Typical Application Circuit (Fixed Version)

10.1.1 Design Requirements

- Input capacitor for stability
- Output capacitor for loop stability and ripple filtering
- Catch diode to filter noise
- Output inductor depending on the mode of operation

10.1.2 Detailed Design Procedure

10.1.2.1 Input Capacitor (C_{IN})

For stability concerns, an input bypass capacitor (electrolytic, $C_{IN} \geq 47 \mu\text{F}$) needs to be located as close as possible to the regulator. For operating temperatures below -25°C , C_{IN} may need to be larger in value. In addition, since most electrolytic capacitors have decreasing capacitances and increasing ESR as temperature drops, adding a ceramic or solid tantalum capacitor in parallel increases the stability in cold temperatures.

To extend the capacitor operating lifetime, the capacitor RMS ripple current rating should be calculated as shown in Equation 1.

$$I_{C,RMS} > 1.2 (t_{on} / T) I_{LOAD}$$

where

- $t_{on}/T = V_{OUT}/V_{IN}$ {buck regulator}
- $t_{on}/T = |V_{OUT}|/(|V_{OUT}| + V_{IN})$ {buck-boost regulator}

(1)

10.1.2.2 Output Capacitor (C_{OUT})

For both loop stability and filtering of ripple voltage, an output capacitor is required, again in close proximity to the regulator. For best performance, low-ESR aluminum electrolytics are recommended, although standard aluminum electrolytics may be adequate for some applications as shown in Equation 2.

$$\text{Output ripple voltage} = (\text{ESR of } C_{OUT}) \times (\text{inductor ripple current})$$

(2)

Typical Application (continued)

Output ripple of 50 mV to 150 mV typically can be achieved with capacitor values of 220 μ F to 680 μ F. Larger C_{OUT} can reduce the ripple 20 mV to 50 mV peak to peak. To improve further on output ripple, paralleling of standard electrolytic capacitors may be used. Alternatively, higher-grade capacitors such as high frequency, low inductance, or low ESR can be used.

The following should be taken into account when selecting C_{OUT} :

- At cold temperatures, the ESR of the electrolytic capacitors can rise dramatically (typically 3 \times nominal value at -25° C). Because solid-tantalum capacitors have significantly better ESR specifications at cold temperatures, they should be used at operating temperature lower than -25° C. As an alternative, tantalums can also be paralleled to aluminum electrolytics and should contribute 10% to 20% to the total capacitance.
- Low ESR for C_{OUT} is desirable for low output ripple. However, the ESR should be greater than 0.05 Ω to avoid the possibility of regulator instability. Hence, a sole tantalum capacitor used for C_{OUT} is most susceptible to this occurrence.
- The ripple current rating of the capacitor, 52 kHz, should be at least 50% higher than the peak-to-peak inductor ripple current.

10.1.2.3 Catch Diode

As with other external components, the catch diode should be placed close to the output to minimize unwanted noise. Schottky diodes have fast switching speeds and low forward voltage drops and, thus, offer the best performance, especially for switching regulators with low output voltages ($V_{OUT} < 5$ V). If a high-efficiency, fast-recovery, or ultra-fast-recovery diode is used in place of a Schottky, it should have a soft recovery (versus abrupt turn-off characteristics) to avoid the chance of causing instability and EMI. Standard 50- to 60-Hz diodes, such as the 1N4001 or 1N5400 series, are not suitable.

10.1.2.4 Inductor

Proper inductor selection is key to the performance-switching power-supply designs. One important factor to consider is whether the regulator is used in continuous mode (inductor current flows continuously and never drops to zero) or in discontinuous mode (inductor current goes to zero during the normal switching cycle). Each mode has distinctively different operating characteristics and, therefore, can affect the regulator performance and requirements. In many applications, the continuous mode is the preferred mode of operation, since it offers greater output power with lower peak currents, and also can result in lower output ripple voltage. The advantages of continuous mode of operation come at the expense of a larger inductor required to keep inductor current continuous, especially at low output currents and/or high input voltages.

The TL2575 and TL2575HV devices can operate in either continuous or discontinuous mode. With heavy load currents, the inductor current flows continuously and the regulator operates in continuous mode. Under light load, the inductor fully discharges and the regulator is forced into the discontinuous mode of operation. For light loads (approximately 200 mA or less), this discontinuous mode of operation is perfectly acceptable and may be desirable solely to keep the inductor value and size small. Any buck regulator eventually operates in discontinuous mode when the load current is light enough.

The type of inductor chosen can have advantages and disadvantages. If high performance or high quality is a concern, then more-expensive toroid core inductors are the best choice, as the magnetic flux is contained completely within the core, resulting in less EMI and noise in nearby sensitive circuits. Inexpensive bobbin core inductors, however, generate more EMI as the open core does not confine the flux within the core. Multiple switching regulators located in proximity to each other are particularly susceptible to mutual coupling of magnetic fluxes from each other's open cores. In these situations, closed magnetic structures (such as a toroid, pot core, or E-core) are more appropriate.

Regardless of the type and value of inductor used, the inductor never should carry more than its rated current. Doing so may cause the inductor to saturate, in which case the inductance quickly drops, and the inductor looks like a low-value resistor (from the dc resistance of the windings). As a result, switching current rises dramatically (until limited by the current-by-current limiting feature of the TL2575 and TL2575HV devices) and can result in overheating of the inductor and the IC itself.

NOTE

Different types of inductors have different saturation characteristics.

Typical Application (continued)

10.1.2.5 Output Voltage Ripple and Transients

As with any switching power supply, the output of the TL2575 and TL2575HV devices have a sawtooth ripple voltage at the switching frequency. Typically about 1% of the output voltage, this ripple is due mainly to the inductor sawtooth ripple current and the ESR of the output capacitor (see [Output Capacitor \(C_{OUT}\)](#)). Furthermore, the output also may contain small voltage spikes at the peaks of the sawtooth waveform. This is due to the fast switching of the output switch and the parasitic inductance of C_{OUT}. These voltage spikes can be minimized through the use of low-inductance capacitors.

There are several ways to reduce the output ripple voltage: a larger inductor, a larger C_{OUT}, or both. Another method is to use a small LC filter (20 μH and 100 μF) at the output. This filter can reduce the output ripple voltage by a factor of 10 (see [Figure 11](#)).

10.1.2.6 Grounding

The power and ground connections of the TL2575 and TL2575HV devices must be low impedance to help maintain output stability. For the 5-pin packages, both pin 3 and tab are ground, and either connection can be used as they are both part of the same lead frame. With the 16-pin package, all the ground pins (including signal and power grounds) should be soldered directly to wide PCB copper traces to ensure low-inductance connections and good thermal dissipation.

10.1.2.7 Reverse Current Considerations

There is an internal diode from the output to VIN. Therefore, the device does not protect against reverse current and care must be taken to limit current in this scenario.

10.1.2.8 Buck Regulator Design Procedure

PROCEDURE (Fixed Output)	EXAMPLE (Fixed Output)
<p>Known: V_{OUT} = 3.3 V, 5 V, 12 V, or 15 V V_{IN(Max)} = Maximum input voltage I_{LOAD(Max)} = Maximum load current</p>	<p>Known: V_{OUT} = 5 V V_{IN(Max)} = 20 V I_{LOAD(Max)} = 1 A</p>
<p>1. Inductor Selection (L1)</p> <p>A. From Figure 13 through Figure 16, select the appropriate inductor code based on the intersection of V_{IN(Max)} and I_{LOAD(Max)}.</p> <p>B. The inductor chosen should be rated for operation at 52-kHz and have a current rating of at least 1.15 × I_{LOAD(Max)} to allow for the ripple current. The actual peak current in L1 (in normal operation) can be calculated as follows: $I_{L1(pk)} = I_{LOAD(Max)} + (V_{IN} - V_{OUT}) \times t_{on} / 2L1$ Where $t_{on} = V_{OUT} / V_{IN} \times (1 / f_{osc})$</p>	<p>1. Inductor Selection (L1)</p> <p>A. From Figure 14 (TL2575-05), the intersection of 20-V line and 1-A line gives an inductor code of L330.</p> <p>B. L330 → L1 = 330 μH Choose from: 34042 (Schott) PE-52627 (Pulse Engineering) RL1952 (Renco)</p>
<p>2. Output Capacitor Selection (C_{OUT})</p> <p>A. The TL2575 control loop has a two-pole two-zero frequency response. The dominant pole-zero pair is established by C_{OUT} and L1. To meet stability requirements while maintaining an acceptable output ripple voltage (V_{ripple} ≠ 0.01 × V_{OUT}), the recommended range for a standard aluminum electrolytic C_{OUT} is between 100 μF and 470 μF.</p> <p>B. C_{OUT} should have a voltage rating of at least 1.5 × V_{OUT}. But if a low output ripple voltage is desired, choose capacitors with a higher-voltage ratings than the minimum required, due to their typically lower ESRs.</p>	<p>2. Output Capacitor Selection (C_{OUT})</p> <p>A. C_{OUT} = 100-μF to 470-μF, standard aluminum electrolytic</p> <p>B. Although a C_{OUT} rated at 8 V is sufficient for V_{OUT} = 5 V, a higher-voltage capacitor is chosen for its typically lower ESR (and hence lower output ripple voltage) → Capacitor voltage rating = 20 V.</p>
<p>3. Catch Diode Selection (D1) (see Table 1)</p>	<p>3. Catch Diode Selection (D1) (see Table 1)</p>

Typical Application (continued)

PROCEDURE (Fixed Output)	EXAMPLE (Fixed Output)
<p>A. In normal operation, the catch diode requires a current rating of at least $1.2 \times I_{LOAD(Max)}$. For the most robust design, D1 should be rated to handle a current equal to the TL2575 maximum switch peak current; this represents the worst-case scenario of a continuous short at V_{OUT}.</p> <p>B. The diode requires a reverse voltage rating of at least $1.25 \times V_{IN(Max)}$.</p>	<p>A. Pick a diode with 3-A rating.</p> <p>B. Pick 30-V rated Schottky diode (1N5821, MBR330, 31QD03, or SR303) or 100-V rated Fast Recovery diode (31DF1, MURD310, or HER302).</p>
<p>4. Input Capacitor (C_{IN}) An aluminum electrolytic or tantalum capacitor is needed for input bypassing. Locate C_{IN} as close to the V_{IN} and GND pins as possible.</p>	<p>4. Input Capacitor (C_{IN}) $C_{IN} = 100 \mu\text{F}$, 25 V, aluminum electrolytic</p>

PROCEDURE (Adjustable Output)	EXAMPLE (Adjustable Output)
<p>Known: $V_{OUT(Nom)}$ $V_{IN(Max)}$ = Maximum input voltage $I_{LOAD(Max)}$ = Maximum load current</p>	<p>Known: $V_{OUT} = 10 \text{ V}$ $V_{IN(Max)} = 25 \text{ V}$ $I_{LOAD(Max)} = 1 \text{ A}$</p>
<p>1. Programming Output Voltage (Selecting R1 and R2) Referring to Figure 2, V_{OUT} is defined by: $V_{OUT} = V_{REF} \left(1 + \frac{R2}{R1} \right) \quad \text{where } V_{REF} = 1.23 \text{ V}$ Choose a value for R1 between 1 kΩ and 5 kΩ (use 1% metal-film resistors for best temperature coefficient and stability over time). $R2 = R1 \left(\frac{V_{OUT}}{V_{REF}} - 1 \right)$</p>	<p>1. Programming Output Voltage (Selecting R1 and R2) Select R1 = 1 kΩ R2 = 1 (10 / 1.23 – 1) = 7.13 kΩ Select R2 = 7.15 kΩ (closest 1% value)</p>
<p>2. Inductor Selection (L1)</p> <p>A. Calculate the "set" volts-second ($E \times T$) across L1: $E \times T = (V_{IN} - V_{OUT}) \times t_{on}$ $E \times T = (V_{IN} - V_{OUT}) \times (V_{OUT} / V_{IN}) \times \{1000 / f_{osc}(\text{in kHz})\} [\text{V} \times \mu\text{s}]$ NOTE: Along with I_{LOAD}, the "set" volts-second ($E \times T$) constant establishes the minimum energy storage requirement for the inductor.</p> <p>B. Using Figure 17, select the appropriate inductor code based on the intersection of $E \times T$ value and $I_{LOAD(Max)}$.</p> <p>C. The inductor chosen should be rated for operation at 52-kHz and have a current rating of at least $1.15 \times I_{LOAD(Max)}$ to allow for the ripple current. The actual peak current in L1 (in normal operation) can be calculated as follows: $I_{L1(pk)} = I_{LOAD(Max)} + (V_{IN} - V_{OUT}) \times t_{on} / 2L1$ Where $t_{on} = V_{OUT} / V_{IN} \times (1 / f_{osc})$</p>	<p>2. Inductor Selection (L1)</p> <p>A. Calculate the "set" volts-second ($E \times T$) across L1: $E \times T = (25 - 10) \times (10 / 25) \times (1000 / 52) [\text{V} \times \mu\text{s}]$ $E \times T = 115 \text{ V} \times \mu\text{s}$</p> <p>B. Using Figure 17, the intersection of 115 V • μs and 1 A corresponds to an inductor code of H470.</p> <p>C. H470 \rightarrow L1 = 470 μH Choose from: 34048 (Schott) PE-53118 (Pulse Engineering) RL1961 (Renco)</p>
<p>3. Output Capacitor Selection (C_{OUT})</p> <p>A. The TL2575 control loop has a two-pole two-zero frequency response. The dominant pole-zero pair is established by C_{OUT} and L1. To meet stability requirements, C_{OUT} must meet the following requirement: $C_{OUT} \geq 7758 \frac{V_{IN(Max)}}{V_{OUT} \cdot L1(\mu\text{H})} (\mu\text{F})$ However, C_{OUT} may need to be several times larger than the calculated value above in order to achieve an acceptable output ripple voltage of $\sim 0.01 \times V_{OUT}$.</p>	<p>3. Output Capacitor Selection (C_{OUT})</p> <p>A. $C_{OUT} \geq 7785 \times 25 / (10 \times 470) [\mu\text{F}]$ $C_{OUT} \geq 41.4 \mu\text{F}$ To obtain an acceptable output voltage ripple \rightarrow $C_{OUT} = 220 \mu\text{F}$ electrolytic</p>

PROCEDURE (Adjustable Output)	EXAMPLE (Adjustable Output)
<p>B. C_{OUT} should have a voltage rating of at least 1.5 × V_{OUT}. But if a low output ripple voltage is desired, choose capacitors with a higher voltage ratings than the minimum required due to their typically lower ESRs.</p>	
<p>4. Catch Diode Selection (D1) (see Table 1)</p> <p>A. In normal operation, the catch diode requires a current rating of at least 1.2 × I_{LOAD(Max)}. For the most robust design, D1 should be rated for a current equal to the TL2575 maximum switch peak current; this represents the worst-case scenario of a continuous short at V_{OUT}.</p> <p>B. The diode requires a reverse voltage rating of at least 1.25 × V_{IN(Max)}.</p>	<p>4. Catch Diode Selection (D1) (see Table 1)</p> <p>A. Pick a diode with a 3-A rating.</p> <p>B. Pick a 40-V rated Schottky diode (1N5822, MBR340, 31QD04, or SR304) or 100-V rated Fast Recovery diode (31DF1, MURD310, or HER302)</p>
<p>5. Input Capacitor (C_{IN})</p> <p>An aluminum electrolytic or tantalum capacitor is needed for input bypassing. Locate C_{IN} as close to V_{IN} and GND pins as possible.</p>	<p>5. Input Capacitor (C_{IN})</p> <p>C_{IN} = 100 μF, 35 V, aluminum electrolytic</p>

Table 1. Diode Selection Guide

V _R	SCHOTTKY		FAST RECOVERY	
	1A	3A	1A	3A
20 V	1N5817 MBR120P SR102	1N5820 MBR320 SR302	The following diodes are all rated to 100 V: 11DF1 MUR110 HER102	The following diodes are all rated to 100 V: 31DF1 MURD310 HER302
30 V	1N5818 MBR130P 11DQ03 SR103	1N5821 MBR330 31DQ03 SR303		
40 V	1N5819 MBR140P 11DQ04 SR104	1N5822 MBR340 31DQ04 SR304		
50 V	MBR150 11DQ05 SR105	MBR350 31DQ05 SR305		
60 V	MBR160 11DQ06 SR106	MBR360 31DQ06 SR306		

10.1.2.9 Inductor Selection Guide

Inductor Value Selection Guide for Continuous-Mode Operation

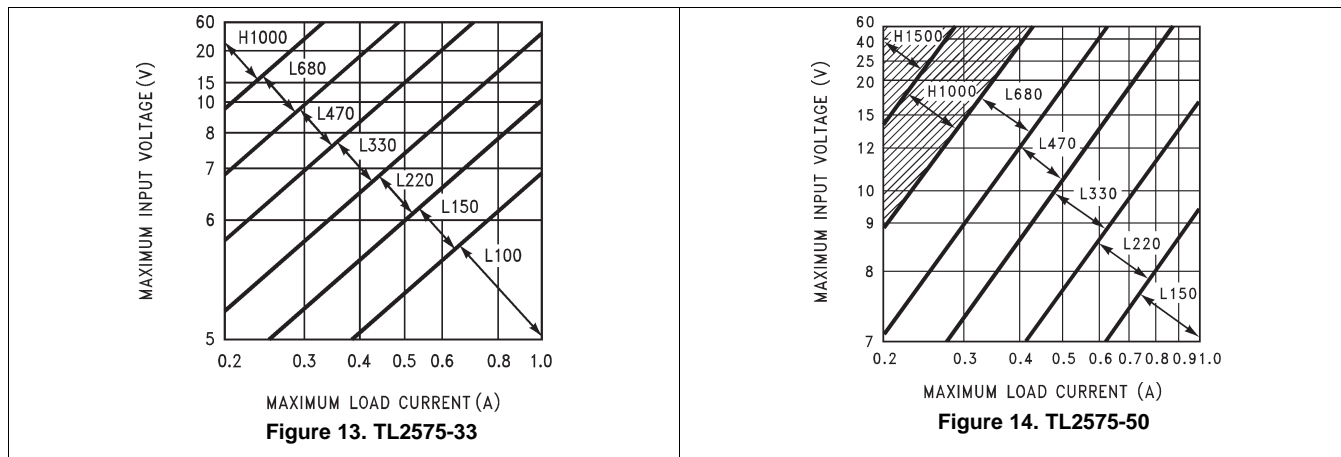

Inductor Value Selection Guide for Continuous-Mode Operation

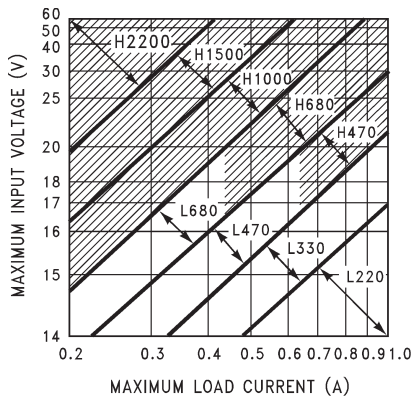

Figure 15. TL2575-12

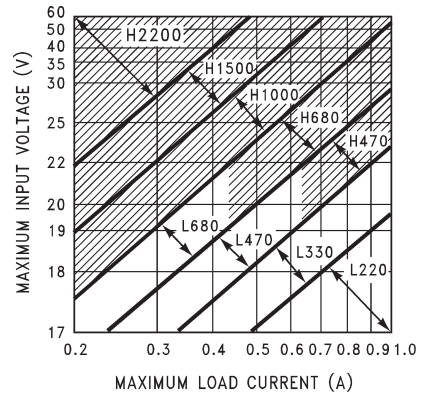

Figure 16. TL2575-15

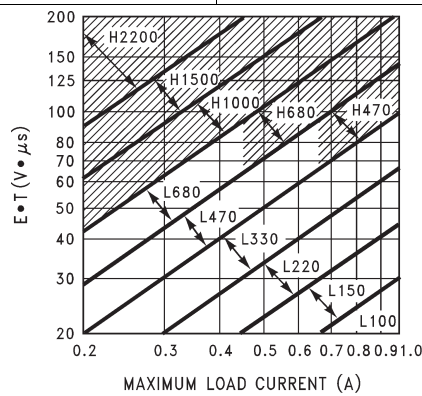
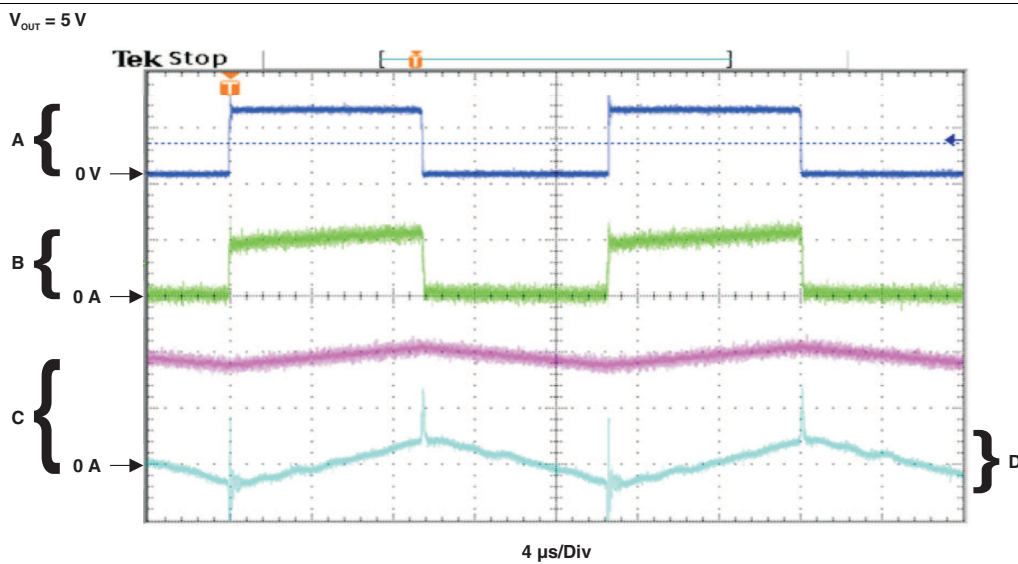

Figure 17. TL2575-ADJ

10.1.3 Application Curves



Output ripple voltage, 20 mV/Div

Figure 18. Switching Waveforms

Inductor Value Selection Guide for Continuous-Mode Operation

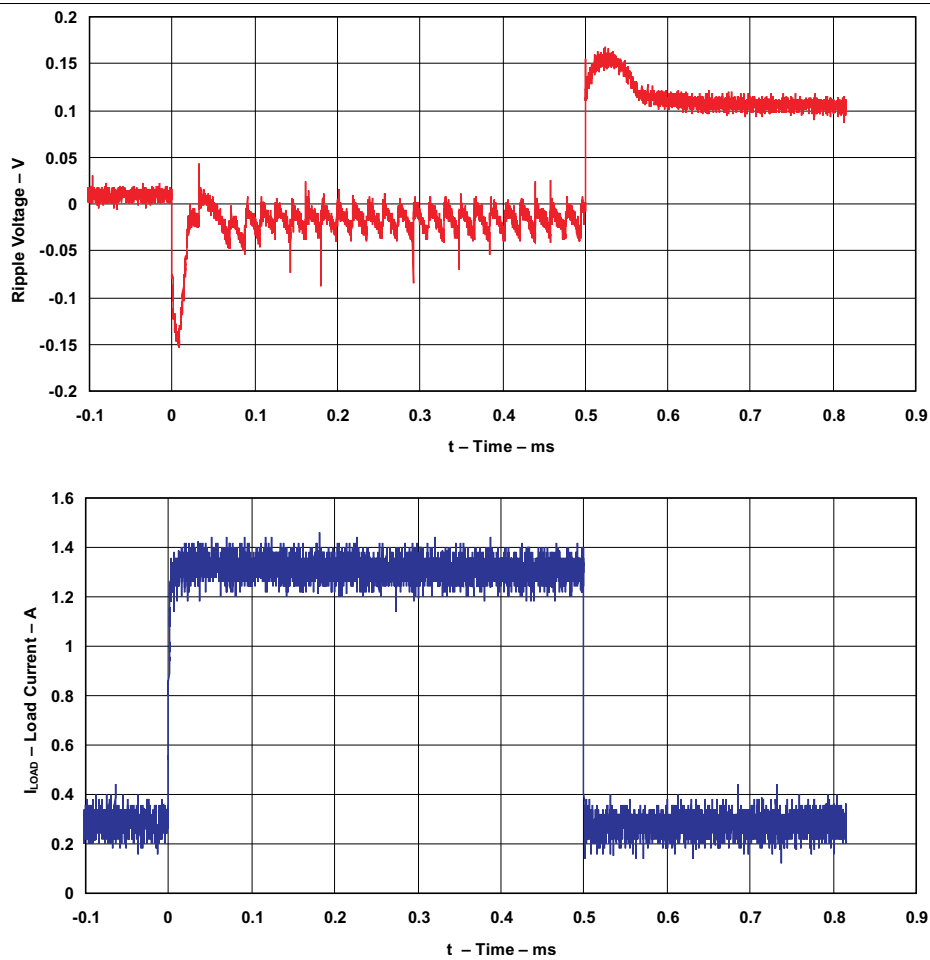

Figure 19. Load Transient Response

11 Power Supply Recommendations

This device operates with a power supply range of 4.75 V to 40 V (60 V for the TL2575-HV). A 100- μ F decoupling capacitor is recommended on the input to filter noise.

12 Layout

12.1 Layout Guidelines

With any switching regulator, circuit layout plays an important role in circuit performance. Wiring and parasitic inductances, as well as stray capacitances, are subjected to rapidly switching currents, which can result in unwanted voltage transients. To minimize inductance and ground loops, the length of the leads indicated by heavy lines should be minimized. Optimal results can be achieved by single-point grounding (see [Figure 11](#)) or by ground-plane construction. For the same reasons, the two programming resistors used in the adjustable version should be located as close as possible to the regulator to keep the sensitive feedback wiring short.

12.2 Layout Example

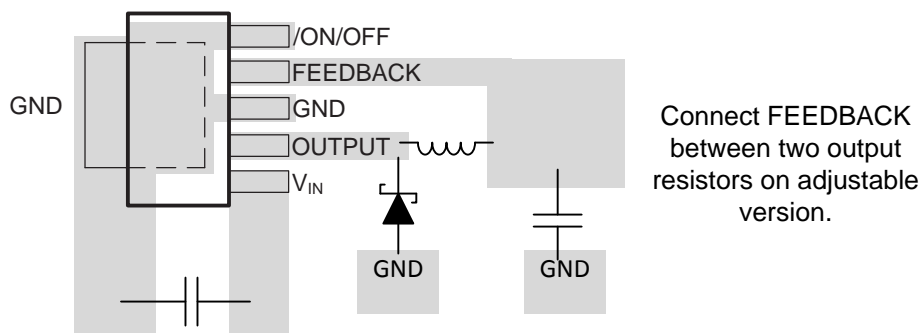

Figure 20. Layout Diagram (KV Package)

13 Device and Documentation Support

13.1 Related Links

The table below lists quick access links. Categories include technical documents, support and community resources, tools and software, and quick access to sample or buy.

Table 2. Related Links

PARTS	PRODUCT FOLDER	SAMPLE & BUY	TECHNICAL DOCUMENTS	TOOLS & SOFTWARE	SUPPORT & COMMUNITY
TL2575	Click here	Click here	Click here	Click here	Click here
TL2575HV	Click here	Click here	Click here	Click here	Click here

13.2 Trademarks

All trademarks are the property of their respective owners.

13.3 Electrostatic Discharge Caution



These devices have limited built-in ESD protection. The leads should be shorted together or the device placed in conductive foam during storage or handling to prevent electrostatic damage to the MOS gates.

13.4 Glossary

[SLYZ022](#) — *TI Glossary*.

This glossary lists and explains terms, acronyms, and definitions.

14 Mechanical, Packaging, and Orderable Information

The following pages include mechanical, packaging, and orderable information. This information is the most current data available for the designated devices. This data is subject to change without notice and revision of this document. For browser-based versions of this data sheet, refer to the left-hand navigation.

PACKAGING INFORMATION

Orderable Device	Status (1)	Package Type	Package Drawing	Pins	Package Qty	Eco Plan (2)	Lead/Ball Finish (6)	MSL Peak Temp (3)	Op Temp (°C)	Device Marking (4/5)	Samples
TL2575-05IKTTR	ACTIVE	DDPAK/ TO-263	KTT	5	500	Green (RoHS & no Sb/Br)	CU SN	Level-3-245C-168 HR	-40 to 125	TL2575-05I	Samples
TL2575-05IKTTRG3	ACTIVE	DDPAK/ TO-263	KTT	5	500	Green (RoHS & no Sb/Br)	CU SN	Level-3-245C-168 HR	-40 to 125	TL2575-05I	Samples
TL2575-05IKV	ACTIVE	TO-220	KV	5	50	Pb-Free (RoHS)	CU SN	N / A for Pkg Type	-40 to 125	TL2575-05I	Samples
TL2575-05IN	ACTIVE	PDIP	N	16	25	Pb-Free (RoHS)	CU NIPDAU	N / A for Pkg Type	-40 to 125	TL2575-05IN	Samples
TL2575-12IKTTR	ACTIVE	DDPAK/ TO-263	KTT	5	500	Green (RoHS & no Sb/Br)	CU SN	Level-3-245C-168 HR	-40 to 125	TL2575-12I	Samples
TL2575-12IKV	ACTIVE	TO-220	KV	5	50	Pb-Free (RoHS)	CU SN	N / A for Pkg Type	-40 to 125	TL2575-12I	Samples
TL2575-12IN	ACTIVE	PDIP	N	16	25	Pb-Free (RoHS)	CU NIPDAU	N / A for Pkg Type	-40 to 125	TL2575-12IN	Samples
TL2575-15IKTTR	ACTIVE	DDPAK/ TO-263	KTT	5	500	Green (RoHS & no Sb/Br)	CU SN	Level-3-245C-168 HR	-40 to 125	TL2575-15I	Samples
TL2575-15IKV	ACTIVE	TO-220	KV	5	50	Pb-Free (RoHS)	CU SN	N / A for Pkg Type	-40 to 125	TL2575-15I	Samples
TL2575-15IN	ACTIVE	PDIP	N	16	25	Pb-Free (RoHS)	CU NIPDAU	N / A for Pkg Type	-40 to 125	TL2575-15IN	Samples
TL2575-33IKTTR	ACTIVE	DDPAK/ TO-263	KTT	5	500	Green (RoHS & no Sb/Br)	CU SN	Level-3-245C-168 HR	-40 to 125	TL2575-33I	Samples
TL2575-33IKV	ACTIVE	TO-220	KV	5	50	Pb-Free (RoHS)	CU SN	N / A for Pkg Type	-40 to 125	TL2575-33I	Samples
TL2575-33IN	ACTIVE	PDIP	N	16	25	Pb-Free (RoHS)	CU NIPDAU	N / A for Pkg Type	-40 to 125	TL2575-33IN	Samples
TL2575-ADJIKTTR	ACTIVE	DDPAK/ TO-263	KTT	5	500	Green (RoHS & no Sb/Br)	CU SN	Level-3-245C-168 HR	-40 to 125	TL2575ADJI	Samples
TL2575-ADJIKTTRG3	ACTIVE	DDPAK/ TO-263	KTT	5	500	Green (RoHS & no Sb/Br)	CU SN	Level-3-245C-168 HR	-40 to 125	TL2575ADJI	Samples
TL2575-ADJIKV	ACTIVE	TO-220	KV	5	50	Pb-Free (RoHS)	CU SN	N / A for Pkg Type	-40 to 125	TL2575ADJI	Samples
TL2575-ADJIN	ACTIVE	PDIP	N	16	25	Pb-Free (RoHS)	CU NIPDAU	N / A for Pkg Type	-40 to 125	TL2575-ADJIN	Samples

Orderable Device	Status (1)	Package Type	Package Drawing	Pins	Package Qty	Eco Plan (2)	Lead/Ball Finish (6)	MSL Peak Temp (3)	Op Temp (°C)	Device Marking (4/5)	Samples
TL2575-ADJINE4	ACTIVE	PDIP	N	16	25	Pb-Free (RoHS)	CU NIPDAU	N / A for Pkg Type	-40 to 125	TL2575-ADJIN	Samples
TL2575HV-05IKTTR	ACTIVE	DDPAK/ TO-263	KTT	5	500	Green (RoHS & no Sb/Br)	CU SN	Level-3-245C-168 HR	-40 to 125	2BHV-05I	Samples
TL2575HV-05IKV	ACTIVE	TO-220	KV	5	50	Pb-Free (RoHS)	CU SN	N / A for Pkg Type	-40 to 125	TL2575HV-05I	Samples
TL2575HV-05IN	ACTIVE	PDIP	N	16	25	Pb-Free (RoHS)	CU NIPDAU	N / A for Pkg Type	-40 to 125	TL2575HV-05IN	Samples
TL2575HV-12IKTTR	ACTIVE	DDPAK/ TO-263	KTT	5	500	Green (RoHS & no Sb/Br)	CU SN	Level-3-245C-168 HR	-40 to 125	2BHV-12I	Samples
TL2575HV-12IKV	ACTIVE	TO-220	KV	5	50	Pb-Free (RoHS)	CU SN	N / A for Pkg Type	-40 to 125	TL2575HV-12I	Samples
TL2575HV-12IN	ACTIVE	PDIP	N	16	25	Pb-Free (RoHS)	CU NIPDAU	N / A for Pkg Type	-40 to 125	TL2575HV-12IN	Samples
TL2575HV-15IKTTR	ACTIVE	DDPAK/ TO-263	KTT	5	500	Green (RoHS & no Sb/Br)	CU SN	Level-3-245C-168 HR	-40 to 125	2BHV-15I	Samples
TL2575HV-15IKV	ACTIVE	TO-220	KV	5	50	Pb-Free (RoHS)	CU SN	N / A for Pkg Type	-40 to 125	TL2575HV-15I	Samples
TL2575HV-15IN	ACTIVE	PDIP	N	16	25	Pb-Free (RoHS)	CU NIPDAU	N / A for Pkg Type	-40 to 125	TL2575HV-15IN	Samples
TL2575HV-33IKTTR	ACTIVE	DDPAK/ TO-263	KTT	5	500	Green (RoHS & no Sb/Br)	CU SN	Level-3-245C-168 HR	-40 to 125	2BHV-33I	Samples
TL2575HV-33IKV	ACTIVE	TO-220	KV	5	50	Pb-Free (RoHS)	CU SN	N / A for Pkg Type	-40 to 125	TL2575HV-33I	Samples
TL2575HV-33IN	ACTIVE	PDIP	N	16	25	Pb-Free (RoHS)	CU NIPDAU	N / A for Pkg Type	-40 to 125	TL2575HV-33IN	Samples
TL2575HV-ADJIKTTR	ACTIVE	DDPAK/ TO-263	KTT	5	500	Green (RoHS & no Sb/Br)	CU SN	Level-3-245C-168 HR	-40 to 125	2BHV-ADJI	Samples
TL2575HV-ADJIKV	ACTIVE	TO-220	KV	5	50	Pb-Free (RoHS)	CU SN	N / A for Pkg Type	-40 to 125	TL2575HVADJI	Samples
TL2575HV-ADJIN	ACTIVE	PDIP	N	16	25	Pb-Free (RoHS)	CU NIPDAU	N / A for Pkg Type	-40 to 125	TL2575HV-ADJIN	Samples

(1) The marketing status values are defined as follows:

ACTIVE: Product device recommended for new designs.

LIFEBUY: TI has announced that the device will be discontinued, and a lifetime-buy period is in effect.

NRND: Not recommended for new designs. Device is in production to support existing customers, but TI does not recommend using this part in a new design.

PREVIEW: Device has been announced but is not in production. Samples may or may not be available.

OBSOLETE: TI has discontinued the production of the device.

⁽²⁾ **RoHS:** TI defines "RoHS" to mean semiconductor products that are compliant with the current EU RoHS requirements for all 10 RoHS substances, including the requirement that RoHS substance do not exceed 0.1% by weight in homogeneous materials. Where designed to be soldered at high temperatures, "RoHS" products are suitable for use in specified lead-free processes. TI may reference these types of products as "Pb-Free".

RoHS Exempt: TI defines "RoHS Exempt" to mean products that contain lead but are compliant with EU RoHS pursuant to a specific EU RoHS exemption.

Green: TI defines "Green" to mean the content of Chlorine (Cl) and Bromine (Br) based flame retardants meet JS709B low halogen requirements of ≤ 1000 ppm threshold. Antimony trioxide based flame retardants must also meet the ≤ 1000 ppm threshold requirement.

⁽³⁾ MSL, Peak Temp. - The Moisture Sensitivity Level rating according to the JEDEC industry standard classifications, and peak solder temperature.

⁽⁴⁾ There may be additional marking, which relates to the logo, the lot trace code information, or the environmental category on the device.

⁽⁵⁾ Multiple Device Markings will be inside parentheses. Only one Device Marking contained in parentheses and separated by a "~" will appear on a device. If a line is indented then it is a continuation of the previous line and the two combined represent the entire Device Marking for that device.

⁽⁶⁾ Lead/Ball Finish - Orderable Devices may have multiple material finish options. Finish options are separated by a vertical ruled line. Lead/Ball Finish values may wrap to two lines if the finish value exceeds the maximum column width.

Important Information and Disclaimer: The information provided on this page represents TI's knowledge and belief as of the date that it is provided. TI bases its knowledge and belief on information provided by third parties, and makes no representation or warranty as to the accuracy of such information. Efforts are underway to better integrate information from third parties. TI has taken and continues to take reasonable steps to provide representative and accurate information but may not have conducted destructive testing or chemical analysis on incoming materials and chemicals. TI and TI suppliers consider certain information to be proprietary, and thus CAS numbers and other limited information may not be available for release.

In no event shall TI's liability arising out of such information exceed the total purchase price of the TI part(s) at issue in this document sold by TI to Customer on an annual basis.

OTHER QUALIFIED VERSIONS OF TL2575HV-05, TL2575HV-33 :

- Automotive: [TL2575HV-05-Q1](#), [TL2575HV-33-Q1](#)

NOTE: Qualified Version Definitions:

- Automotive - Q100 devices qualified for high-reliability automotive applications targeting zero defects

TAPE AND REEL INFORMATION

QUADRANT ASSIGNMENTS FOR PIN 1 ORIENTATION IN TAPE

*All dimensions are nominal

Device	Package Type	Package Drawing	Pins	SPQ	Reel Diameter (mm)	Reel Width W1 (mm)	A0 (mm)	B0 (mm)	K0 (mm)	P1 (mm)	W (mm)	Pin1 Quadrant
TL2575-05IKTTR	DDPAK/ TO-263	KTT	5	500	330.0	24.4	10.8	16.3	5.11	16.0	24.0	Q2
TL2575-05IKTTR	DDPAK/ TO-263	KTT	5	500	330.0	24.4	10.8	16.1	4.9	16.0	24.0	Q2
TL2575-12IKTTR	DDPAK/ TO-263	KTT	5	500	330.0	24.4	10.8	16.3	5.11	16.0	24.0	Q2
TL2575-15IKTTR	DDPAK/ TO-263	KTT	5	500	330.0	24.4	10.8	16.3	5.11	16.0	24.0	Q2
TL2575-33IKTTR	DDPAK/ TO-263	KTT	5	500	330.0	24.4	10.8	16.3	5.11	16.0	24.0	Q2
TL2575-33IKTTR	DDPAK/ TO-263	KTT	5	500	330.0	24.4	10.8	16.1	4.9	16.0	24.0	Q2
TL2575-ADJIKTTR	DDPAK/ TO-263	KTT	5	500	330.0	24.4	10.8	16.1	4.9	16.0	24.0	Q2
TL2575-ADJIKTTR	DDPAK/ TO-263	KTT	5	500	330.0	24.4	10.8	16.3	5.11	16.0	24.0	Q2
TL2575HV-05IKTTR	DDPAK/ TO-263	KTT	5	500	330.0	24.4	10.8	16.1	4.9	16.0	24.0	Q2
TL2575HV-05IKTTR	DDPAK/ TO-263	KTT	5	500	330.0	24.4	10.8	16.3	5.11	16.0	24.0	Q2
TL2575HV-12IKTTR	DDPAK/ TO-263	KTT	5	500	330.0	24.4	10.8	16.3	5.11	16.0	24.0	Q2

Device	Package Type	Package Drawing	Pins	SPQ	Reel Diameter (mm)	Reel Width W1 (mm)	A0 (mm)	B0 (mm)	K0 (mm)	P1 (mm)	W (mm)	Pin1 Quadrant
	TO-263											
TL2575HV-15IKTTR	DDPAK/TO-263	KTT	5	500	330.0	24.4	10.8	16.3	5.11	16.0	24.0	Q2
TL2575HV-33IKTTR	DDPAK/TO-263	KTT	5	500	330.0	24.4	10.8	16.1	4.9	16.0	24.0	Q2
TL2575HV-33IKTTR	DDPAK/TO-263	KTT	5	500	330.0	24.4	10.8	16.3	5.11	16.0	24.0	Q2
TL2575HV-ADJIKTTR	DDPAK/TO-263	KTT	5	500	330.0	24.4	10.8	16.1	4.9	16.0	24.0	Q2
TL2575HV-ADJIKTTR	DDPAK/TO-263	KTT	5	500	330.0	24.4	10.8	16.3	5.11	16.0	24.0	Q2

TAPE AND REEL BOX DIMENSIONS



*All dimensions are nominal

Device	Package Type	Package Drawing	Pins	SPQ	Length (mm)	Width (mm)	Height (mm)
TL2575-05IKTTR	DDPAK/TO-263	KTT	5	500	340.0	340.0	38.0
TL2575-05IKTTR	DDPAK/TO-263	KTT	5	500	350.0	334.0	47.0
TL2575-12IKTTR	DDPAK/TO-263	KTT	5	500	340.0	340.0	38.0
TL2575-15IKTTR	DDPAK/TO-263	KTT	5	500	340.0	340.0	38.0
TL2575-33IKTTR	DDPAK/TO-263	KTT	5	500	340.0	340.0	38.0
TL2575-33IKTTR	DDPAK/TO-263	KTT	5	500	350.0	334.0	47.0
TL2575-ADJIKTTR	DDPAK/TO-263	KTT	5	500	350.0	334.0	47.0

Device	Package Type	Package Drawing	Pins	SPQ	Length (mm)	Width (mm)	Height (mm)
TL2575-ADJIKTTR	DDPAK/TO-263	KTT	5	500	340.0	340.0	38.0
TL2575HV-05IKTTR	DDPAK/TO-263	KTT	5	500	350.0	334.0	47.0
TL2575HV-05IKTTR	DDPAK/TO-263	KTT	5	500	340.0	340.0	38.0
TL2575HV-12IKTTR	DDPAK/TO-263	KTT	5	500	340.0	340.0	38.0
TL2575HV-15IKTTR	DDPAK/TO-263	KTT	5	500	340.0	340.0	38.0
TL2575HV-33IKTTR	DDPAK/TO-263	KTT	5	500	350.0	334.0	47.0
TL2575HV-33IKTTR	DDPAK/TO-263	KTT	5	500	340.0	340.0	38.0
TL2575HV-ADJIKTTR	DDPAK/TO-263	KTT	5	500	350.0	334.0	47.0
TL2575HV-ADJIKTTR	DDPAK/TO-263	KTT	5	500	340.0	340.0	38.0

N (R-PDIP-T**)

PLASTIC DUAL-IN-LINE PACKAGE

16 PINS SHOWN



4040049/E 12/2002

- NOTES:
- A. All linear dimensions are in inches (millimeters).
 - B. This drawing is subject to change without notice.
 - (C) Falls within JEDEC MS-001, except 18 and 20 pin minimum body length (Dim A).
 - (D) The 20 pin end lead shoulder width is a vendor option, either half or full width.

KTT (R-PSFM-G5)

PLASTIC FLANGE-MOUNT PACKAGE

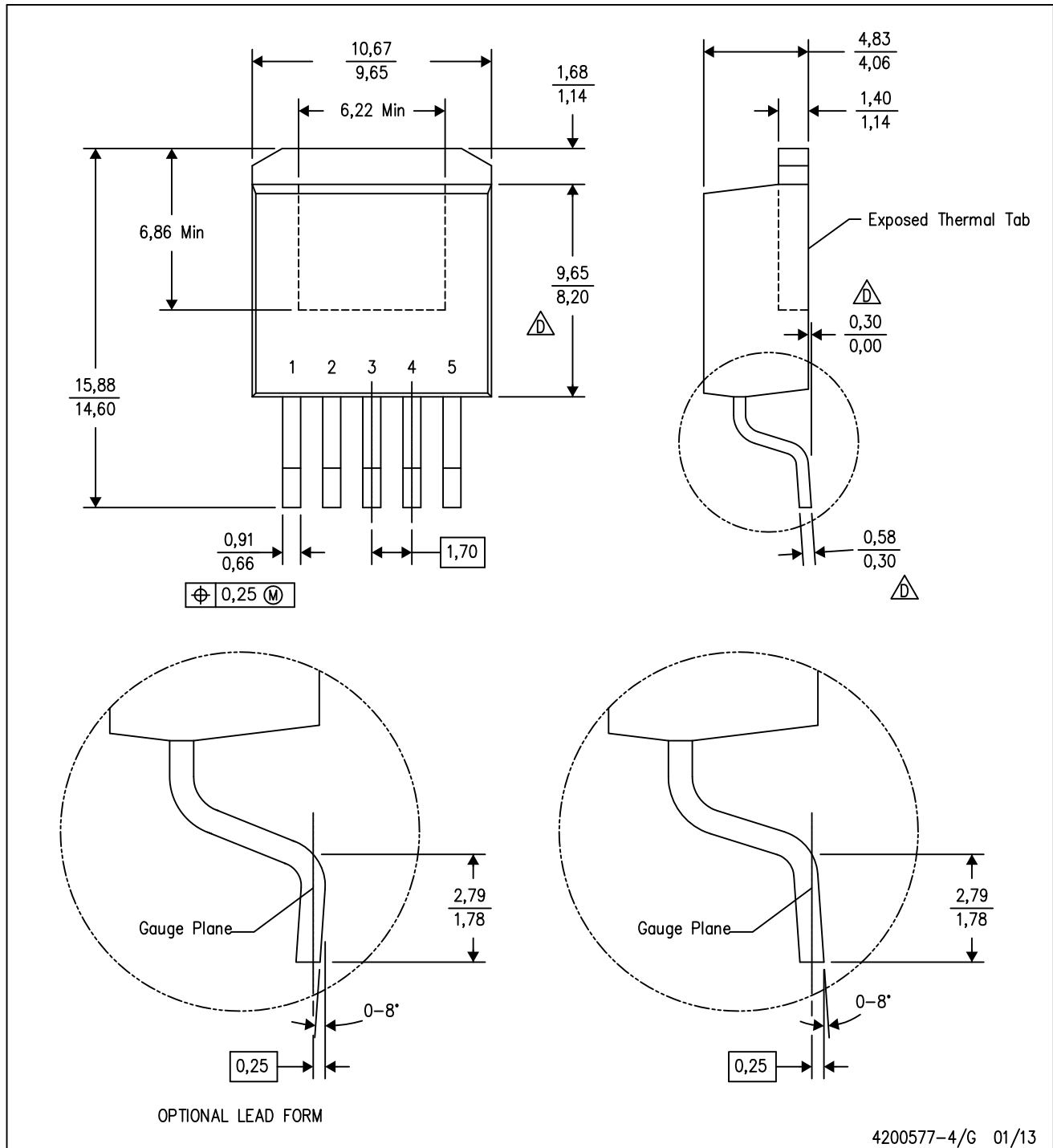

- NOTES:
- A. All linear dimensions are in millimeters.
 - B. This drawing is subject to change without notice.
 - C. Body dimensions do not include mold flash or protrusion. Mold flash or protrusion not to exceed 0.005 (0,13) per side.
- △ Falls within JEDEC TO-263 variation BA, except minimum lead thickness, maximum seating height, and minimum body length.

KTT (R-PSFM-G5)

PLASTIC FLANGE-MOUNT PACKAGE

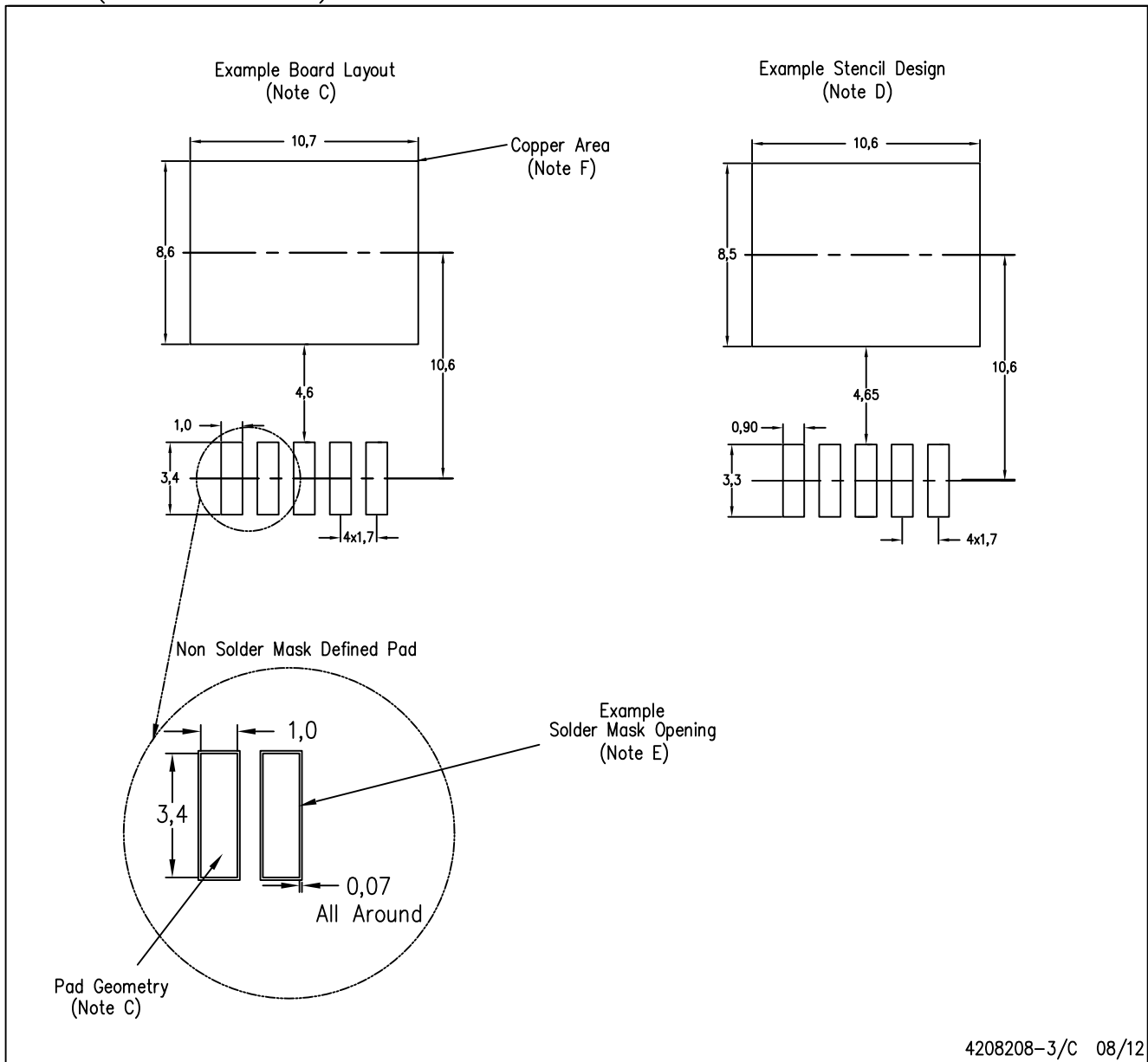

4208208-3/C 08/12

- NOTES:
- All linear dimensions are in millimeters.
 - This drawing is subject to change without notice.
 - Publication IPC-SM-782 is recommended for alternate designs.
 - Laser cutting apertures with trapezoidal walls and also rounding corners will offer better paste release. Customers should contact their board assembly site for stencil design recommendations. Refer to IPC-7525.
 - Customers should contact their board fabrication site for solder mask tolerances between and around signal pads.
 - This package is designed to be soldered to a thermal pad on the board. Refer to the Product Datasheet for specific thermal information, via requirements, and recommended thermal pad size. For thermal pad sizes larger than shown a solder mask defined pad is recommended in order to maintain the solderable pad geometry while increasing copper area.

KV (R-PZFM-T5)

PLASTIC FLANGE-MOUNT PACKAGE

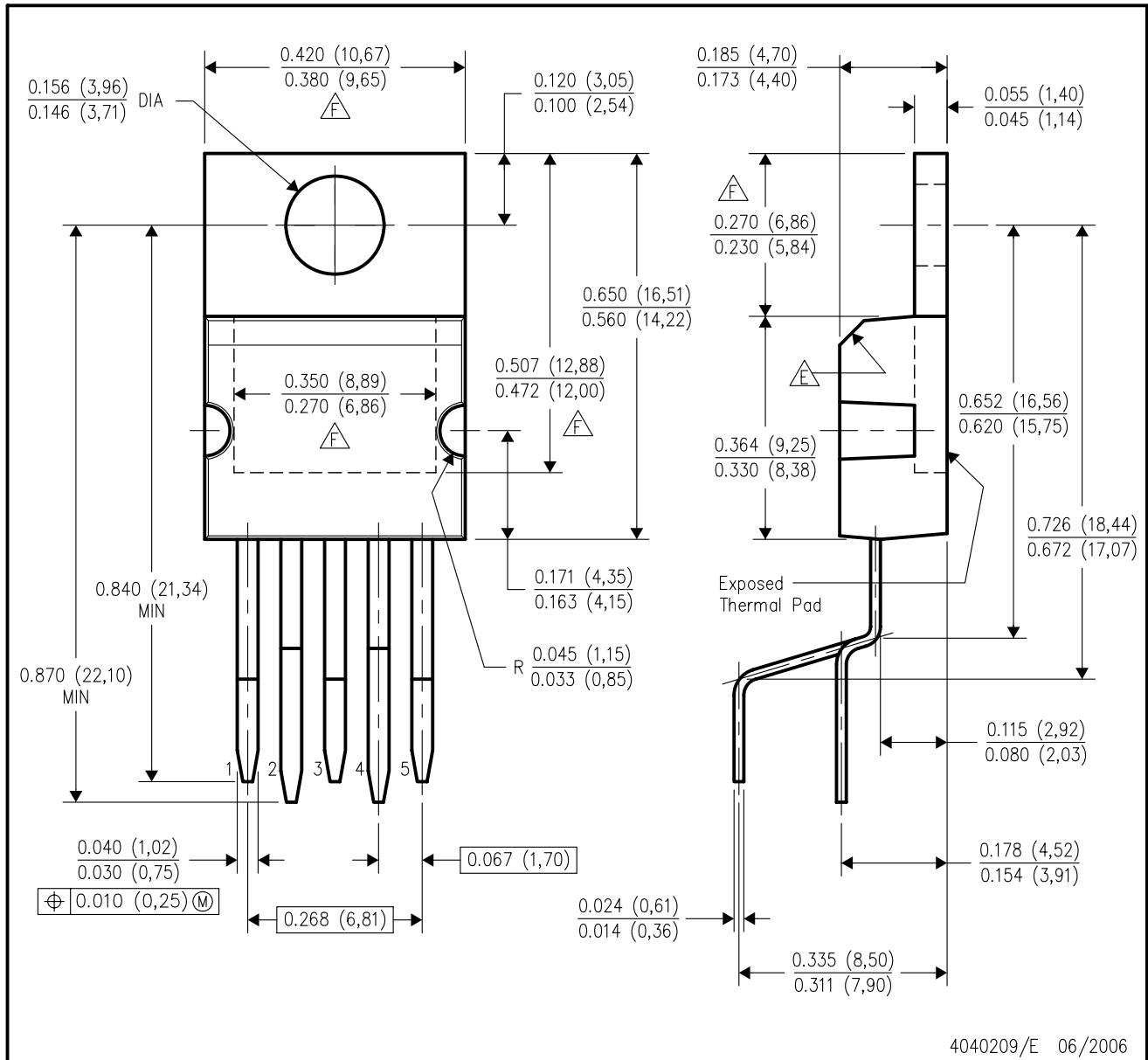

- NOTES:
- A. All linear dimensions are in inches (millimeters).
 - B. This drawing is subject to change without notice.
 - C. All lead dimensions apply before solder dip.
 - D. The center lead is in electrical contact with the mounting tab.
- △ The chamfer is optional.
- △ Thermal pad contour optional within these dimensions.

IMPORTANT NOTICE

Texas Instruments Incorporated (TI) reserves the right to make corrections, enhancements, improvements and other changes to its semiconductor products and services per JESD46, latest issue, and to discontinue any product or service per JESD48, latest issue. Buyers should obtain the latest relevant information before placing orders and should verify that such information is current and complete.

TI's published terms of sale for semiconductor products (<http://www.ti.com/sc/docs/stdterms.htm>) apply to the sale of packaged integrated circuit products that TI has qualified and released to market. Additional terms may apply to the use or sale of other types of TI products and services.

Reproduction of significant portions of TI information in TI data sheets is permissible only if reproduction is without alteration and is accompanied by all associated warranties, conditions, limitations, and notices. TI is not responsible or liable for such reproduced documentation. Information of third parties may be subject to additional restrictions. Resale of TI products or services with statements different from or beyond the parameters stated by TI for that product or service voids all express and any implied warranties for the associated TI product or service and is an unfair and deceptive business practice. TI is not responsible or liable for any such statements.

Buyers and others who are developing systems that incorporate TI products (collectively, "Designers") understand and agree that Designers remain responsible for using their independent analysis, evaluation and judgment in designing their applications and that Designers have full and exclusive responsibility to assure the safety of Designers' applications and compliance of their applications (and of all TI products used in or for Designers' applications) with all applicable regulations, laws and other applicable requirements. Designer represents that, with respect to their applications, Designer has all the necessary expertise to create and implement safeguards that (1) anticipate dangerous consequences of failures, (2) monitor failures and their consequences, and (3) lessen the likelihood of failures that might cause harm and take appropriate actions. Designer agrees that prior to using or distributing any applications that include TI products, Designer will thoroughly test such applications and the functionality of such TI products as used in such applications.

TI's provision of technical, application or other design advice, quality characterization, reliability data or other services or information, including, but not limited to, reference designs and materials relating to evaluation modules, (collectively, "TI Resources") are intended to assist designers who are developing applications that incorporate TI products; by downloading, accessing or using TI Resources in any way, Designer (individually or, if Designer is acting on behalf of a company, Designer's company) agrees to use any particular TI Resource solely for this purpose and subject to the terms of this Notice.

TI's provision of TI Resources does not expand or otherwise alter TI's applicable published warranties or warranty disclaimers for TI products, and no additional obligations or liabilities arise from TI providing such TI Resources. TI reserves the right to make corrections, enhancements, improvements and other changes to its TI Resources. TI has not conducted any testing other than that specifically described in the published documentation for a particular TI Resource.

Designer is authorized to use, copy and modify any individual TI Resource only in connection with the development of applications that include the TI product(s) identified in such TI Resource. NO OTHER LICENSE, EXPRESS OR IMPLIED, BY ESTOPPEL OR OTHERWISE TO ANY OTHER TI INTELLECTUAL PROPERTY RIGHT, AND NO LICENSE TO ANY TECHNOLOGY OR INTELLECTUAL PROPERTY RIGHT OF TI OR ANY THIRD PARTY IS GRANTED HEREIN, including but not limited to any patent right, copyright, mask work right, or other intellectual property right relating to any combination, machine, or process in which TI products or services are used. Information regarding or referencing third-party products or services does not constitute a license to use such products or services, or a warranty or endorsement thereof. Use of TI Resources may require a license from a third party under the patents or other intellectual property of the third party, or a license from TI under the patents or other intellectual property of TI.

TI RESOURCES ARE PROVIDED "AS IS" AND WITH ALL FAULTS. TI DISCLAIMS ALL OTHER WARRANTIES OR REPRESENTATIONS, EXPRESS OR IMPLIED, REGARDING RESOURCES OR USE THEREOF, INCLUDING BUT NOT LIMITED TO ACCURACY OR COMPLETENESS, TITLE, ANY EPIDEMIC FAILURE WARRANTY AND ANY IMPLIED WARRANTIES OF MERCHANTABILITY, FITNESS FOR A PARTICULAR PURPOSE, AND NON-INFRINGEMENT OF ANY THIRD PARTY INTELLECTUAL PROPERTY RIGHTS. TI SHALL NOT BE LIABLE FOR AND SHALL NOT DEFEND OR INDEMNIFY DESIGNER AGAINST ANY CLAIM, INCLUDING BUT NOT LIMITED TO ANY INFRINGEMENT CLAIM THAT RELATES TO OR IS BASED ON ANY COMBINATION OF PRODUCTS EVEN IF DESCRIBED IN TI RESOURCES OR OTHERWISE. IN NO EVENT SHALL TI BE LIABLE FOR ANY ACTUAL, DIRECT, SPECIAL, COLLATERAL, INDIRECT, PUNITIVE, INCIDENTAL, CONSEQUENTIAL OR EXEMPLARY DAMAGES IN CONNECTION WITH OR ARISING OUT OF TI RESOURCES OR USE THEREOF, AND REGARDLESS OF WHETHER TI HAS BEEN ADVISED OF THE POSSIBILITY OF SUCH DAMAGES.

Unless TI has explicitly designated an individual product as meeting the requirements of a particular industry standard (e.g., ISO/TS 16949 and ISO 26262), TI is not responsible for any failure to meet such industry standard requirements.

Where TI specifically promotes products as facilitating functional safety or as compliant with industry functional safety standards, such products are intended to help enable customers to design and create their own applications that meet applicable functional safety standards and requirements. Using products in an application does not by itself establish any safety features in the application. Designers must ensure compliance with safety-related requirements and standards applicable to their applications. Designer may not use any TI products in life-critical medical equipment unless authorized officers of the parties have executed a special contract specifically governing such use. Life-critical medical equipment is medical equipment where failure of such equipment would cause serious bodily injury or death (e.g., life support, pacemakers, defibrillators, heart pumps, neurostimulators, and implantables). Such equipment includes, without limitation, all medical devices identified by the U.S. Food and Drug Administration as Class III devices and equivalent classifications outside the U.S.

TI may expressly designate certain products as completing a particular qualification (e.g., Q100, Military Grade, or Enhanced Product). Designers agree that it has the necessary expertise to select the product with the appropriate qualification designation for their applications and that proper product selection is at Designers' own risk. Designers are solely responsible for compliance with all legal and regulatory requirements in connection with such selection.

Designer will fully indemnify TI and its representatives against any damages, costs, losses, and/or liabilities arising out of Designer's non-compliance with the terms and provisions of this Notice.

Looking for pricing, stock, or lifecycle information?

Click below to explore more details on WIN SOURCE:

 [View TL2575HV-33IN](#) on WIN SOURCE

 [Texas Instruments](#) Information

Optimize Your Supply Chain with WIN SOURCE Solutions

-  Global Sourcing Solution
-  Obsolete Management
-  Cost Control Management
-  Shortage Management
-  Alternative Solution
-  Excess Inventory Management