

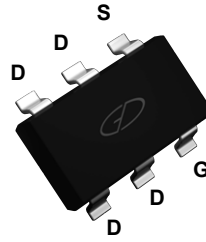


**THE DATASHEET OF  
SSF3051G7**

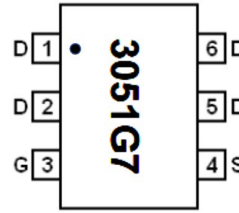


### Main Product Characteristics

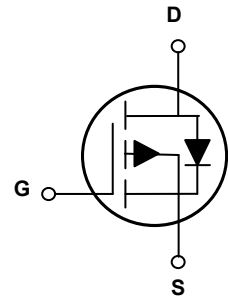
$V_{DSS}$	-30V
$R_{DS(ON)}$	41m $\Omega$ (Typ.)
$I_D$	-4.4A



SOT-23-6L



Marking and Pin Assignment



Schematic Diagram

### Features and Benefits

- Advanced MOSFET process technology
- Ideal for high efficiency switched mode power supplies
- Low on-resistance with low gate charge
- Fast switching and reverse body recovery



### Description

The SSF3051G7 utilizes the latest techniques to achieve high cell density and low on-resistance. These features make this device extremely efficient and reliable for use in high efficiency switch mode power supplies and a wide variety of other applications.

### Absolute Maximum Ratings (T<sub>A</sub>=25°C unless otherwise specified)

Parameter	Symbol	Max.	Unit
Drain-Source Voltage	$V_{DS}$	-30	V
Gate-Source Voltage	$V_{GS}$	±25	V
Drain Current-Continuous @ Current - Pulsed <sup>1</sup>	$I_D$	-4.4	A
Drain Current-Pulsed <sup>2</sup>	$I_{DM}$	-25	A
Maximum Power Dissipation	$P_D$	1.7	W
Thermal Resistance, Junction-to-Ambient <sup>1</sup>	$R_{\theta JA}$	75	°C/W
Thermal Resistance, Junction-to-Case <sup>1</sup>	$R_{\theta JC}$	30	°C/W
Operating Junction Temperature Range	$T_J$	-55 To +150	°C
Storage Temperature Range	$T_{STG}$	-55 To +150	°C



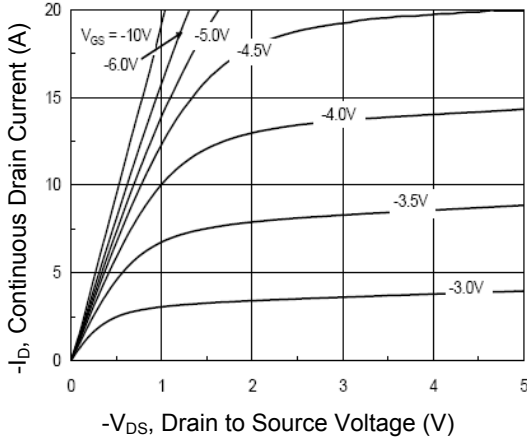
### Electrical Characteristics ( $T_A=25^\circ\text{C}$ unless otherwise specified)

Parameter	Symbol	Conditions	Min.	Typ.	Max.	Unit
<b>On / Off Characteristics</b>						
Drain-Source Breakdown Voltage	$BV_{DSS}$	$V_{GS}=0V, I_D=-250\mu A$	-30	-	-	V
Drain-Source Leakage Current	$I_{DSS}$	$V_{DS}=-24V, V_{GS}=0V$	-	-	-1	$\mu A$
Gate-Source Leakage Current	$I_{GSS}$	$V_{GS}=\pm 25V, V_{DS}=0V$	-	-	$\pm 100$	nA
Static Drain-Source On-Resistance <sup>3</sup>	$R_{DS(ON)}$	$V_{GS}=-10V, I_D=-4.4A$	-	41	48	m $\Omega$
		$V_{GS}=-4.5V, I_D=-3.4A$	-	57	75	
Gate Threshold Voltage <sup>3</sup>	$V_{GS(th)}$	$V_{GS}=V_{DS}, I_D=-250\mu A$	-1	-1.6	-3	V
Forward Transconductance <sup>3</sup>	$g_{fs}$	$V_{DS}=-5V, I_D=-4A$	-	8.5	-	S
<b>Dynamic and Switching Characteristics</b>						
Total Gate Charge <sup>4</sup>	$Q_g$	$V_{DS}=-5V, I_D=-4A, V_{GS}=-5V$	-	7.1	-	nC
Gate-Source Charge <sup>4</sup>	$Q_{gs}$		-	0.86	-	
Gate-Drain Charge <sup>4</sup>	$Q_{gd}$		-	3.9	-	
Turn-On Delay Time <sup>4</sup>	$t_{d(on)}$	$V_{DD}=-15V, R_G=6\Omega, V_{GS}=-10V, I_D=-1A$	-	8.9	-	nS
Rise Time <sup>4</sup>	$t_r$		-	4	-	
Turn-Off Delay Time <sup>4</sup>	$t_{d(off)}$		-	22.6	-	
Fall Time <sup>4</sup>	$t_f$		-	5.5	-	
Input Capacitance <sup>4</sup>	$C_{iss}$	$V_{DS}=-15V, V_{GS}=0V, F=1MHz$	-	520	-	pF
Output Capacitance <sup>4</sup>	$C_{oss}$		-	94	-	
Reverse Transfer Capacitance <sup>4</sup>	$C_{rss}$		-	73	-	
Gate Resistance <sup>3</sup>	$R_g$	$V_{GS}=0V, V_{DS}=0V, F=1MHz$	-	0.95	2	$\Omega$
<b>Drain-Source Diode Characteristics and Maximum Ratings</b>						
Diode Forward Voltage <sup>3</sup>	$V_{SD}$	$V_{GS}=0V, I_S=-1.3A$	-	-0.8	-1.2	V
Continuous Source Current <sup>2</sup>	$I_S$	-	-	-	-4.4	A
Reverse Recovery Time	$t_{rr}$	$T_J=25^\circ\text{C}, I_F=-4A, di/dt=-100A/\mu s$	-	10.3	-	nS
Reverse Recovery Charge	$Q_{rr}$		-	4.3	-	nC

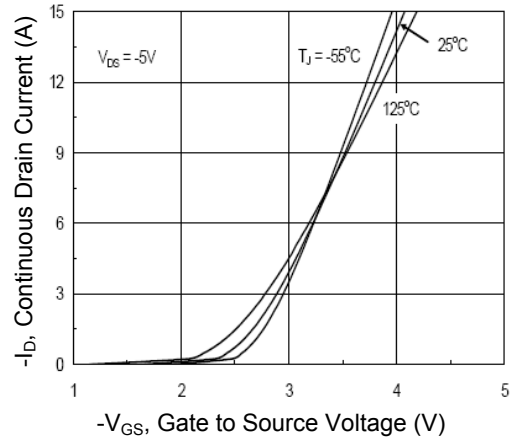
Note:

1. Device mounted on 1"x1" FR-4PC board on 0.1 inch<sup>2</sup> pads on 2oz copper pads and test pulse width  $t \leq 10s$ .
2. Repetitive Rating: pulse width limited by maximum junction temperature.
3. Pulse Test: pulse width  $\leq 300\mu s$ , duty cycle  $\leq 2\%$ .
4. Guaranteed by design, not subject to production testing.

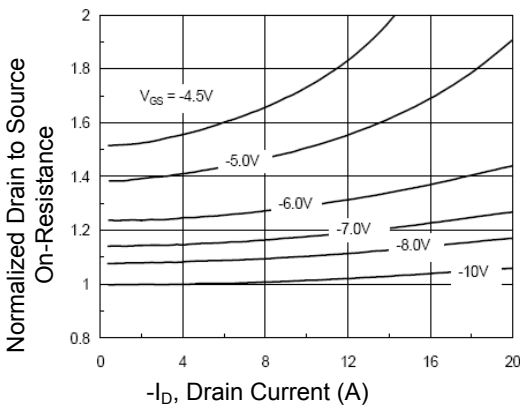
**Typical Electrical and Thermal Characteristics**



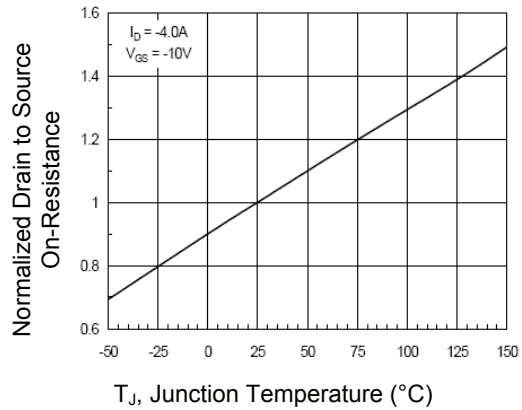
**Figure 1. Typical Output Characteristics**



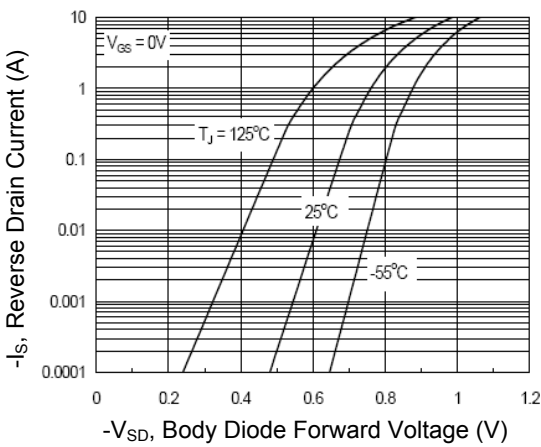
**Figure 2. Transfer Characteristics**



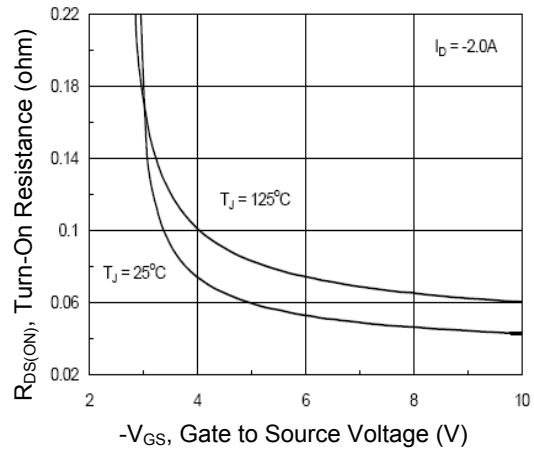
**Figure 3. Drain-Source On-Resistance**



**Figure 4. Drain - Source On-Resistance**

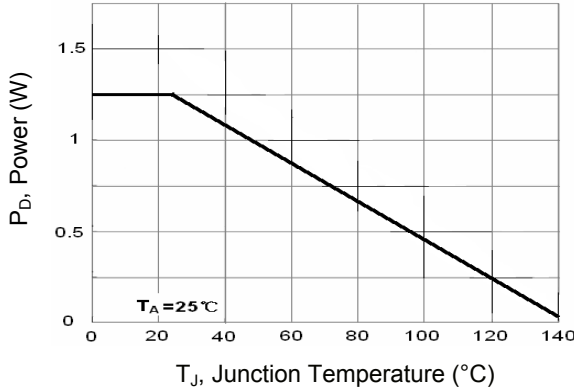


**Figure 5. Source - Drain Diode Forward**

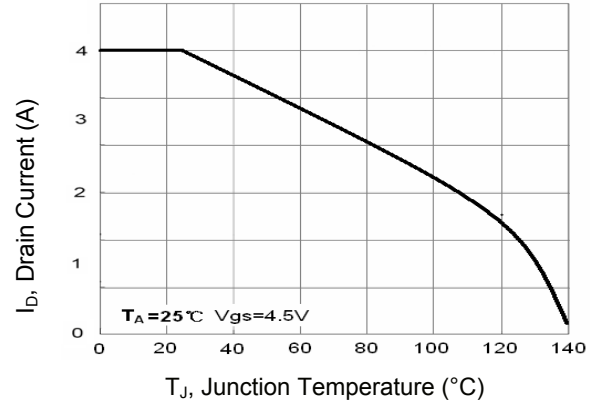


**Figure 6.  $R_{DS(ON)}$  vs.  $V_{GS}$**

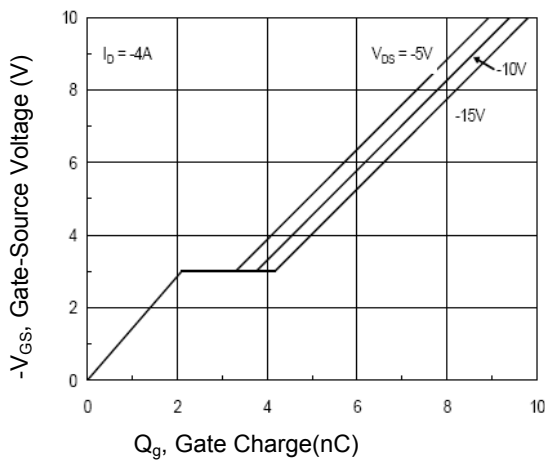
**Typical Electrical and Thermal Characteristics**



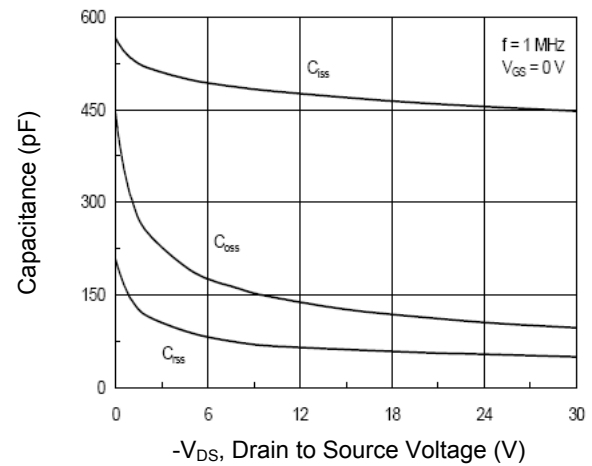
**Figure 7. Power Dissipation**



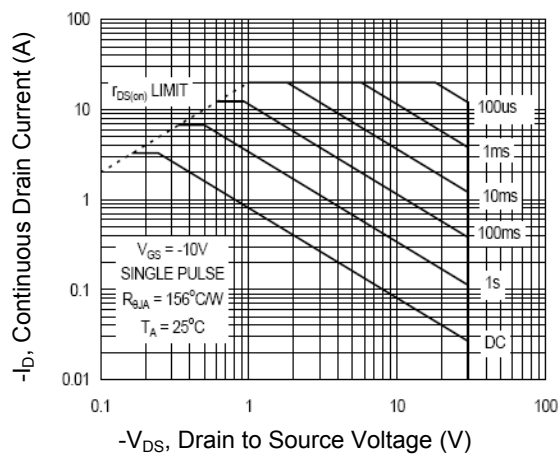
**Figure 8. Drain Current**



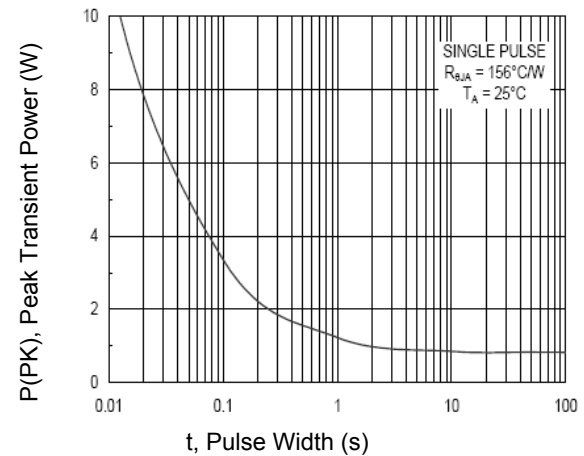
**Figure 9. Gate Charge**



**Figure 10. Capacitance vs.  $V_{DS}$**

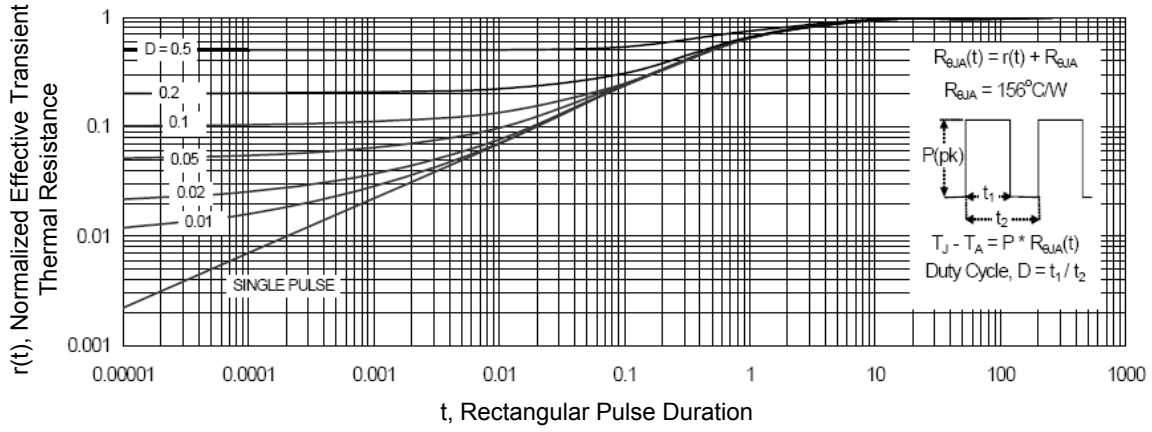


**Figure 11. Safe Operation Area**



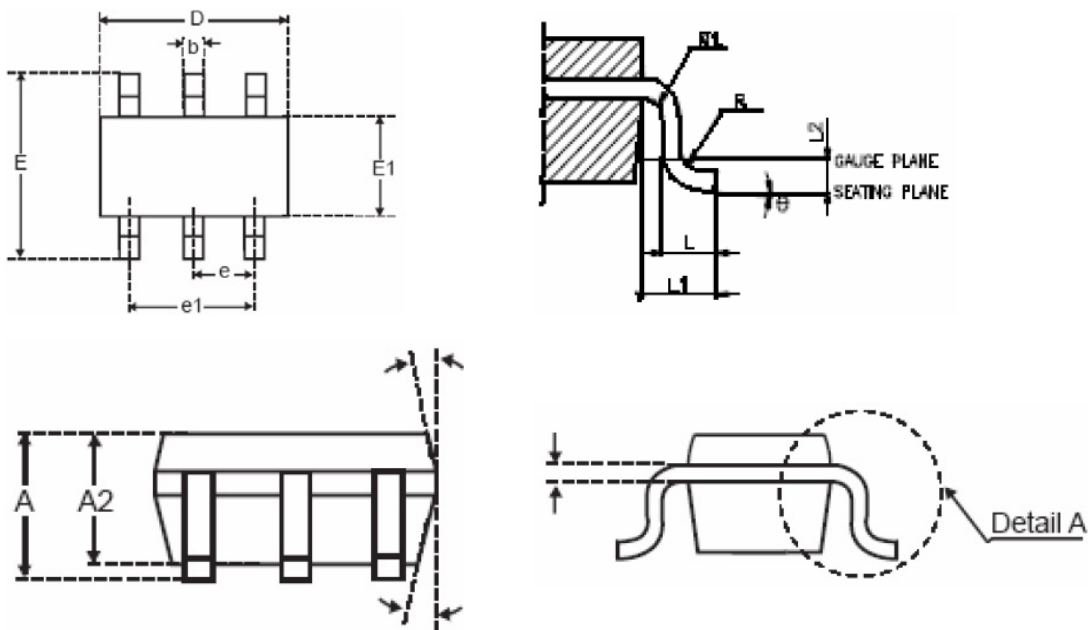
**Figure 12. Single Pulse Maximum Power Dissipation**

**Typical Electrical and Thermal Characteristics**



**Figure 13. Normalized Maximum Transient Thermal Impedance**

**Package Outline Dimensions (SOT-23-6L)**



Symbols	Dimensions in Millimeters		
	Min	Nom	Max
A	-	-	1.45
A1	-	-	0.15
A2	0.9	1.15	1.3
b	0.3	-	0.5
c	0.08	-	0.22
D	2.90 BSC		
E	2.80 BSC		
E1	1.60 BSC		
e	0.95 BSC		
e1	1.90 BSC		
L	0.3	0.45	0.6
L1	0.60 REF		
L2	0.25 BSC		
R	0.1	-	-
R1	0.1	-	0.25
θ	0°	4°	8°
θ1	5°	10°	15°

Note:

1. All dimensions are in millimeters.
2. Dimensions are inclusive of plating.
3. Package body sizes exclude mold flash and gate burrs. Mold flash at the non-lead sides should be less than 6 mils.
4. Dimension L is measured in gauge plane.
5. Controlling dimension is millimeter, converted inch dimensions are not necessarily exact.

### Ordering Information

Device	Package	Marking Code	Carrier	Quantity
SSF3051G7	SOT-23-6L	3051G7	Tape & Reel	3,000 pcs / Reel

## Looking for pricing, stock, or lifecycle information?

Click below to explore more details on WIN SOURCE:

- ⊖ [View SSF3051G7 on WIN SOURCE](#)
- ⊖ [GOOD-ARK Electronics Information](#)

## Optimize Your Supply Chain with WIN SOURCE Solutions

- ✓ Global Sourcing Solution
- ✓ Obsolete Management
- ✓ Cost Control Management
- ✓ Shortage Management
- ✓ Alternative Solution
- ✓ Excess Inventory Management