

PGA450-Q1 Ultrasonic-Sensor Signal Conditioner

1 Features

- Qualified for Automotive Applications
- AEC-Q100 Qualified With the Following Results:
 - Device Temperature Grade 1: –40°C to +125°C Ambient Operating Temperature Range
- Measurements up to 7 Meters through Air
- Dual NMOS Low-Side Drivers
- Configurable Burst Generator
- Low-Noise Amplifier
- 12-Bit SAR ADC
- Configurable Digital Bandpass Filter
- Digital Signal Envelope Detect
- On-Chip 8-Bit Microprocessor
- LIN 2.1 Physical Interface and Protocol
- Watchdog Timer
- Four-Wire SPI for Testability and Programming
- 8K Bytes of OTP
- 768 Bytes of FIFO RAM
- 256 Bytes of Scratchpad RAM
- 8K Bytes of Development RAM
- 32 Bytes of EEPROM for Application

2 Applications

- Automotive Ultrasonic Park Assist
- Intrusion Detection
- Proximity Sensing and Object Detection
- Displacement Sensing
- Large Tank Level Sensing
- Landing Assistance for Drones
- Collision-Avoidance for Drones, Robots and Unmanned Systems

3 Description

The PGA450-Q1 device is a fully integrated system-on-a-chip analog front-end for ultrasonic sensing in automotive park-assist, object-detection through air, level sensing in large tanks, and distance measurements for anti-collision and landing assist of unmanned systems (such as drones, cameras, and robots). This highly integrated device enables a small form-factor and cost-optimized solution compared to discrete ultrasonic-sensor solutions. The PGA450-Q1 device can measure distances ranging from less than 1 meter up to 7 meters, at a resolution of 1 cm depending on the transducer-transformer sensor pair used in the system.

The PGA450-Q1 device has an integrated 8051 8-bit microcontroller and OTP memory for program storage to process the echo signal and calculate the distance between the transducer and targeted object. Full programmability is available for optimization of specific end applications, and to accommodate a wide-range of closed-top or open-top transducers. Configurable variables include the number of transmit pulses, driving frequency, LNA gain, and comparison signal thresholds. External communication with the PGA450-Q1 device is capable through the LIN 2.1 protocol, SPI, or UART interfaces.

Device Information⁽¹⁾

PART NUMBER	PACKAGE	BODY SIZE (NOM)
PGA450-Q1	TSSOP (28)	9.70 mm x 4.40 mm

(1) For all available packages, see the orderable addendum at the end of the data sheet.

Typical Application Diagram

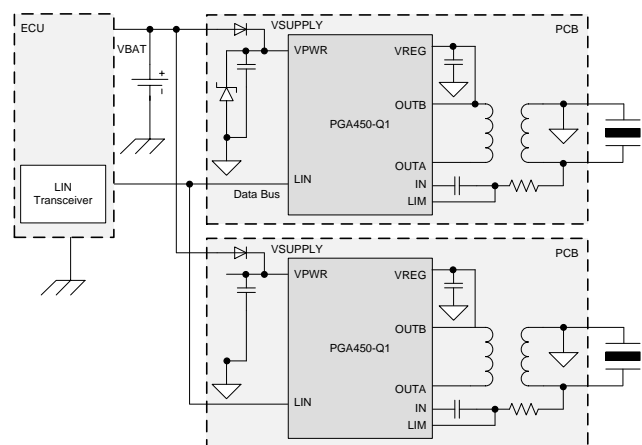

Table of Contents

1 Features	1	7 Detailed Description	14
2 Applications	1	7.1 Overview	14
3 Description	1	7.2 Functional Block Diagram	14
4 Revision History	2	7.3 Feature Description	15
5 Pin Configuration and Functions	4	7.4 Device Functional Modes	54
6 Specifications	5	7.5 Programming	56
6.1 Absolute Maximum Ratings	5	7.6 Register Maps	70
6.2 ESD Ratings: AEC Q100	5	8 Application and Implementation	116
6.3 ESD Ratings: IEC61000-4-2	5	8.1 Application Information	116
6.4 Recommended Operating Conditions	5	8.2 Typical Application	116
6.5 Thermal Information	6	9 Power Supply Recommendations	121
6.6 Electrical Characteristics	6	10 Layout	121
6.7 Electrical Characteristics — LIN 2.1 Slave and Buffered SCI	8	10.1 Layout Guidelines	121
6.8 Electrical Characteristics — SPI Interface	8	10.2 Layout Example	122
6.9 Timing Requirements	8	11 Device and Documentation Support	123
6.10 Timing Requirements — LIN 2.1 Slave and Buffered SCI	9	11.1 Documentation Support	123
6.11 Timing Requirements — SPI Interface	10	11.2 Community Resource	123
6.12 Switching Characteristics	10	11.3 Trademarks	123
6.13 Digital Datapath Filter Switching Characteristics ..	10	11.4 Electrostatic Discharge Caution	123
6.14 Typical Characteristics	13	11.5 Glossary	123
		12 Mechanical, Packaging, and Orderable Information	123

4 Revision History

NOTE: Page numbers for previous revisions may differ from page numbers in the current version.

Changes from Revision C (November 2015) to Revision D	Page
• Changed the bit numbers for the Byte #1 breakdown in the <i>SPI Protocol Transfer Widths</i> table	57
• Added the byte #4 data for the external RAM read in the <i>SPI Protocol Transfer Widths</i> table	57
• Changed the address of the OTP program code area from 0x1000 to 0x0000 in the <i>PGA450 Memory Map</i> figure	70
• Changed the SAT_SEL0 value for 600 mV from 0 to 1 in the <i>SAT_SELx Bit Configuration</i> table	96

Changes from Revision B (June 2015) to Revision C	Page
• Added the measurements and AEC features to the <i>Features</i> section	1
• Changed the list of applications in the <i>Applications</i> section	1
• Changed the <i>Description</i> section	1
• Moved the ESD rating for the IEC61000-4-2 specification into a separate <i>ESD Ratings</i> table	5
• Changed the description of the push-pull drive mode configuration in the <i>Burst Generator</i> section	19
• Changed the address and byte 3 data descriptions for the external RAM read and write in the <i>SPI Protocol Transfer Widths</i> table. Also changed the byte 4 description for the external RAM write	57
• Changed the hex code for INC @Ri in the <i>Instructions</i> table	67
• Added the timer usage for port 3, bit 5 in the <i>8051W I/O Port Usage in PGA450-Q1</i> table	70

Changes from Revision A (April 2012) to Revision B	Page
• Changed <i>Automotive Park Distance</i> to <i>Automotive Park Assist</i> in the <i>Applications</i> and <i>Description</i> sections	1
• Added <i>ESD Ratings</i> table, <i>Feature Description</i> section, <i>Device Functional Modes</i> , <i>Application and Implementation</i> section, <i>Power Supply Recommendations</i> section, <i>Layout</i> section, <i>Device and Documentation Support</i> section, and <i>Mechanical, Packaging, and Orderable Information</i> section	1

• Added the external crystal parameter to the <i>Timing Requirements</i> table	8
• Changed active bit to ACTIVE_EN bit and added VREG_EN; updated <i>Power-Up Waveforms</i> figure in the <i>Power Supply Block</i> section.	16
• Removed ; this field can be updated by the 8051W from the last paragraph in the Clock Synchronizer Using the SYNC Field in the LIN Bus section.....	18
• Updated the <i>Burst Generator</i> figure	20
• Changed all instances of LS in to Low-side in <i>Description</i> column of <i>Low-Side MOSFET Gate Drive Modes ITEM DESCRIPTION</i> table	20
• Changed register names in the description column of the <i>Low-Side MOSFET Gate Drive Modes ITEM DESCRIPTION</i> table: ENABLE CONTROL to EN_CTRL, PULSE COUNT A to PULSE_CNTA, PULSE COUNT B to PULSE_CNTB, BURST_ONA to ON_A, BURST_OFFA to OFF_A, BURST_ONB to ON_B, BURST_OFFB to OFF_B. Removed Set by SFR from Description.....	20
• Changed For TI Use Only to Reserved.....	21
• Updated the <i>Digital Data Path</i> figure.....	23
• Changed MODE bits to mode bits, changed FIFO CONTROL register to FIFO control register and added (FIFO_CTRL) to <i>Datapath Output Format Control</i> section.....	35
• Added (EN_CTRL) and changed ENABLE CONTROL register to enable control register in the <i>Datapath Activation and Blanking Timer</i>	36
• Updated the <i>States of Digital Datapath</i> figure.....	37
• Changed ANALOG MUX ESFR to ANALOG_MUX ESFR, removed all caps for temperature sensor and digital datapath, changed TEMP_CTRL to TEMP_DAC_CTRL in the Digital Datapath Output Mode section.	37
• Added (EN_CTRL), (SAT_DEGLITCH), and (SAT_TIME) register name definitions, changed uppercase register names to lower case, changed second bullet from: SATURATION THRESHOLD register to: Saturation threshold is set by the SAT_SEL1 and SAT_SEL0 bits in CONTROL_1 register in <i>Transducer Saturation Time</i> section.....	37
• Updated the <i>Transducer Saturation-Time Measurement Block</i> figure	37
• Changed ENABLE CONTROL register to EN_CTRL, changed SATURATION DEGLITCH TIME register to SAT_DEGLITCH register, changed SATURATION TIME CAPTURE register to SAT_TIME register, changed sentence from: When this voltage goes below the programmed threshold in the SATURATION THRESHOLD register... to: When this voltage goes below the programmed saturation threshold.....	38
• Changed room temperature to 30°C; changed Temperature = 0.75 to Temperature = 1.75 in <i>Temperature Sensor</i> section.	39
• Updated the <i>Timing Diagram Showing the Measurement of Transducer Saturation Time</i> figure.....	39
• Changed FREE RUNNING TIMER to free-running timer, added (FRT) coin, changed register to ESFR, changed CAP_FR_TMR to CAP_FR_TIMER.	40
• Added: which is stored in the FIFO_POINTER register to FIFO Memory for <i>Digital Datapath Output</i> section.	41
• Deleted <i>unless the entire OTP is erased by a UV-light EPROM eraser</i> from the following sentence: <i>After an address is programmed, it cannot be programmed again.</i> in the <i>OTP Programming</i> section.	43
• Removed: Use MOVX commands to place data in external memory addresses 0x0400 through 0x041F.	45
• Updated the <i>LIN Registers</i> figure	47
• Switched 1 and 0 under HOLD in <i>LIN Frame-Control Configuration</i> section.....	48
• Changed If there is a parity error... to: If there is no parity error... in <i>LIN Slave-Protocol State Machine</i>	49
• Updated the <i>LIN Controller State Machine</i> figure.....	51
• Changed Rx to receive in <i>LIN Slave Protocol Rx</i> section.	51
• Changed receive to transmit and TX to transmit in the <i>LIN Slave Protocol Tx</i> section.	51
• Removed: of the PID field under STOP_BIT_VAL in the <i>LIN Slave Framing Error Status</i> section.	51
• Changed CPU_WD_EN to SW_WD_EN.....	61

5 Pin Configuration and Functions

**PW Package
28-Pin TSSOP
Top View**

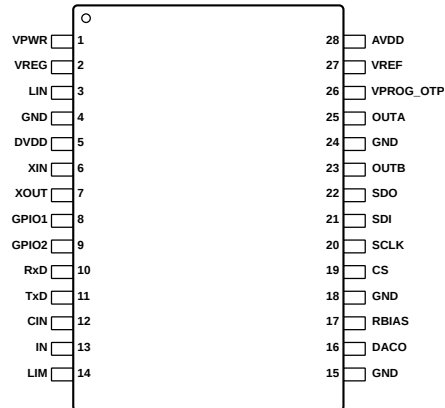

Pin Functions

PIN		I/O	DESCRIPTION
NO.	NAME		
1	VPWR	I	Supply voltage
2	VREG	O	Regulated voltage for transducer
3	LIN	I/O	LIN communication bus
4	GND	—	Ground
15			
18			
24			
5	DVDD	O	Regulated voltage for digital core
6	XIN	I	Crystal input
7	XOUT	O	Crystal out
8	GPIO1	I/O	General-purpose I/O 1 and 2
9	GPIO2		
10	RxD	I	8051W UART Rx (Port 3_0)
11	TxD	O	8051W UART Tx (Port 3_1)
12	CIN	I	Input capacitor
13	IN	I	Transducer receive input
14	LIM	I	Transducer receive limit
16	DACO	O	DAC output
17	RBIAS	I	Bias resistor (100 kΩ to ground)
19	\overline{CS}	I	SPI chip select
20	SCLK	I	SPI clock
21	SDI	I	SPI slave data in
22	SDO	O	SPI slave data out
23	OUTB	O	Transducer drive output B
25	OUTA	O	Transducer drive output A
26	VPROG_OTP	I	OTP programming voltage
27	VREF	O	Reference voltage for ADC
28	AVDD	O	Regulated voltage for analog

6 Specifications

6.1 Absolute Maximum Ratings

over operating free-air temperature range (unless otherwise noted)⁽¹⁾

		MIN	MAX	UNIT
Power-supply voltage	VPWR	−0.3	40	V
Voltage	VREG, VPROG_OTP pin	−0.3	10	V
	LIN	−27	40	V
	RBIAS, CIN, IN	−0.3	3	V
	DVDD, XIN, XOUT	−0.3	2	V
	OUTA, OUTB	−0.3	40	V
	LIM	−1.5	1.5	V
Voltage on all other pins, VMAX		−0.3	6	V
Low-side FET current, IFET			1.5	A
Maximum operating junction temperature, T _{Jmax}		−40	150	°C
Storage temperature, T _{stg}		−40	125	°C

(1) Stresses beyond those listed under *Absolute Maximum Ratings* may cause permanent damage to the device. These are stress ratings only and functional operation of the device at these or any other conditions beyond those indicated under *Recommended Operating Conditions* are not implied. Exposure to Absolute-Maximum-Rated conditions for extended periods may affect device reliability.

6.2 ESD Ratings: AEC Q100

		VALUE	UNIT	
V _(ESD)	Electrostatic discharge	Human body model (HBM), per AEC Q100-002 ⁽¹⁾	±2000	
		Charged device model (CDM), per AEC Q100-011	Corner pins (1, 14, 15, and 28)	±750
			Other pins	±500

(1) AEC Q100-002 indicates HBM stressing is done in accordance with the ANSI/ESDA/JEDEC JS-001 specification.

6.3 ESD Ratings: IEC61000-4-2

		VALUE	UNIT
V _(ESD)	Electrostatic discharge	IEC61000-4-2 ⁽¹⁾ , LIN pin	±8000 V

(1) Per IEC61000-4-2:1995 specification, contact with no external capacitor.

6.4 Recommended Operating Conditions

over operating free-air temperature range (unless otherwise noted)

		MIN	NOM	MAX	UNIT
VPWR	Power-supply voltage	7		18	V
IPWR	Power-supply current	Power up, T _A = 105°C		50	mA
		Active mode ⁽¹⁾ temperature sensor off, T _A = 105°C, VPWR = 18 V		15	mA
		Quiet mode ⁽¹⁾ , T _A = 105°C, VPWR = 18 V		7.5	mA
IPWR _{AVG}	Average power-supply current ⁽¹⁾			10	mA
T _A	Operating ambient temperature	−40		105	°C
C _{VREG}	Capacitance on VREG pin	10		470	μF
C _{VPWR}	Capacitance on VPWR pin ⁽²⁾	47		100	μF
C _{ESR}	ESR of capacitor on VREG pin		2		Ω

(1) The average current is defined as: $I_{pwr(Average)} = 0.3I_{active} + 0.7I_{quiet}$

Active Mode: The entire device is active.

Quiet Mode: LNA, A/D, digital datapath, and OUTA/B are OFF. Microprocessor and LIN are still active. Add 100 mA to these currents if capacitor on VREG is charging

(2) The capacitor value must allow a discharge rate on VPWR to be at most 1 V/ms.

6.5 Thermal Information

THERMAL METRIC ⁽¹⁾		PGA450-Q1	UNIT
		PWP (TSSOP)	
		28 PINS	
R _{θJA}	Junction-to-ambient thermal resistance	68.7	°C/W
R _{θJC}	Junction-to-case (top) thermal resistance	11.6	°C/W
R _{θJB}	Junction-to-board thermal resistance	27.6	°C/W

(1) For more information about traditional and new thermal metrics, see the *Semiconductor and IC Package Thermal Metrics* application report, [SPRA953](#).

6.6 Electrical Characteristics

PARAMETER		TEST CONDITIONS	MIN	TYP	MAX	UNIT
POWER SUPPLY						
VPWR _{POR}	VPWR voltage for POR to occur	POR is deasserted	3		4.2	V
V _{AVDD}	AVDD pin voltage	IAVDD = 5 mA	4.75	5	5.25	V
I _{AVDD}	AVDD pin load current				5	mA
V _{DVDD}	DVDD pin voltage			1.8		V
VREF	VREF pin voltage			3		V
VREG						
VREG _{TOL}	Transducer primary voltage tolerance	I _{REG} = 100 μA VPWR = 7 V VREG_SEL = 0_XXX for 4.7 V–5.4 V VPWR = 10 V VREG_SEL = 1_XXX for 7.7 V–8.4 V		±100		mV
VREG _{CHARGE}	Transducer voltage droop while charging	I _{REG} = 100 mA, below VREG_SEL setting		500		mV
VREG _{READY}	VREG_READY threshold	Below VREG_SEL setting		250		mV
I _{VREG}	VREG output current	VPWR > VREG_SEL + 2.5 V	90	100	110	mA
		VPWR > VREG_SEL + 2 V	100			μA
VREG _{I_S2G}	VREG short-to-ground protection current	VPWR = 16 V, T _A = 105 °C, no burst			110	mA
LOW-SIDE DRIVE MOSFETS						
r _{ds(on)}	FET ON resistance	I _{load} = 500 mA, T _A = 105 °C			1.2	Ω
I _{PULSE}	Drain pulse current	50 kHz			1.5	A
	Drive clamping voltage	V _{gs} = 0 V, I _{dd} = 10 mA	40			V
	Leakage current				5	μA
LOW NOISE AMPLIFIER						
A _V	Gain	LNA_GAIN setting = 0b00	1680	1750	1820	V/V
		LNA_GAIN setting = 0b01	892	930	968	
		LNA_GAIN Setting = 0b10	496	517	538	
		LNA_GAIN Setting = 0b11	99	104	109	
R _{IN}	Input impedance	40 kHz	100			kΩ
	Clamp voltage		-1.5		1.5	V
I _{LIM}	Input current limit				200	mA
	Noise (input-referred of the signal chain)	IN pin = GND, T _A = 105 °C, center frequency = 40 kHz, Bandwidth = 10 kHz		0.7		μVrms
	Input-referred PSRR	VPWR = 7 V, LNA gain setting = 0b00		93		dB
12-BIT ADC						
V _{ADCREf}	Input voltage range		0		3	V
	DNL	20% to 80% input range		2.5		LSB

Electrical Characteristics (continued)

PARAMETER		TEST CONDITIONS	MIN	TYP	MAX	UNIT
	INL	20% to 80% input range, best-fit curve		4		LSB
	Gain	Best-fit curve	1373	1378	1383	LSB/V
	Offset	Best-fit curve		-15		LSB
8-BIT DAC						
V _{DAC_MAX}	Output range		0.133		1.125	V
	Gain			3.9		mV/Code
	Offset voltage	Output when DAC code is 000h at R _{load} = 100 kΩ to GND		0.133		V
	Full-scale voltage	Output when DAC code is 0xFF R _{load} = 100 kΩ to GND		1.125		V
I _{DAC}	Output current	DAC Code = 0x00 DAC Code = 0xFF, R _{load} = 100 kΩ			12.5	μA
	INL		-2		2	LSB
	DNL		-1		1	LSB
	Capacitance load			10		pF
TRANSDUCER SATURATION TIME						
V _{SAT_TH}	Saturation threshold	SAT_SEL = 200 mV		200		mV
		SAT_SEL = 300 mV		300		mV
		SAT_SEL = 400 mV		400		mV
		SAT_SEL = 600 mV		600		mV
TEMPERATURE SENSOR						
	Temperature sensor range		-40		140	°C
	Temperature accuracy	-40°C to 105°C	-5		5	°C
	Temperature sensor code	30°C		0		LSB
	Temperature sensor LSB			1.75		°C/LSB
GPIOs, 8051 UART Tx AND Rx						
V _{IH}	GPIO input mode, high, Rx,	R _{load} > 10 kΩ	3.5		5.3	V
V _{IL}	GPIO input mode, low, Rx		-0.3		1.5	V
R _{PULLUP}	Internal pullup on input	Pullup is to AVDD		100		KΩ
V _{OH}	GPIO strong-mode output, high, Tx	I _{OH} = 5 mA	4			V
V _{OL}	GPIO strong-mode output, low, Tx	I _{OL} = 5 mA			0.8	V
	Total current on GPIO1 + GPIO2 +Tx pin	No load on AVDD pin			5	mA
MEMORY						
	OTP programming voltage		7.5	8	8.5	V
	OTP programming current		2		5	mA
DIAGNOSTICS						
VPWR_OV	VPWR overvoltage level		25	28	32	V
AVDD_UV	VPWR for AVDD undervoltage			5.6		V
AVDD_OC	AVDD Overcurrent		45	55	65	mA
RBIAS_OC	RBIAS Overcurrent		65	80	90	μA
	Low-side driver A/B drain monitor		2.2	2.5	2.8	V
	Low-side driver A/B monitor		2.2	2.5	2.8	V
	Over temperature shut-off protection		150		200	°C

6.7 Electrical Characteristics — LIN 2.1 Slave and Buffered SCI⁽¹⁾⁽²⁾

PARAMETER	TEST CONDITIONS	MIN	TYP	MAX	UNIT
I_{BUS_LIM}	$V_{BUS} = 18\text{ V}$	40		200	mA
$I_{BUS_PAS_dom}$	Driver off, $V_{BUS} = 0\text{ V}$, $V_{PWR} = 12\text{ V}$	-1			mA
$I_{BUS_PAS_rec}$	Driver off, $7\text{ V} < V_{PWR} < 18\text{ V}$, $8\text{ V} < V_{BUS} < 18\text{ V}$, $V_{BUS} > V_{PWR}$			20	μA
$I_{BUS_NO_GND}$	$GND_{Device} = V_{PWR}$, $0 < V_{BUS} < 18\text{ V}$, $V_{PWR} = 12\text{ V}$	-1		1	mA
$I_{BUS_NO_BAT}$	$V_{PWR} = GND$, $0 < V_{BUS} < 18\text{ V}$			100	μA
V_{BUSdom}	Receiver dominant state			0.4	V_{PWR}
V_{BUSrec}	Receiver recessive state	0.6			V_{PWR}
V_{BUS_CNT}	$V_{BUS_CNT} = (V_{th_dom} + V_{th_rec})/2$	0.475	0.5	0.525	V_{PWR}
V_{HYS}	$V_{HYS} = V_{th_rec} - V_{th_dom}$			0.175	V_{PWR}
R_{Slave}	Serial resistor	20	30	60	K Ω
C_{IN}	Input capacitance on LIN pin		60		pF

(1) LIN Mode:

LIN 2.1 physical layer and LIN protocol (Section 2.1 of LIN 2.1) specification

Exceptions: No wake-up (Section 2.6.2 of LIN 2.1)

No transport layer in digital logic (Section 3 of LIN 2.1)

No node configuration and identification services in digital (Section 4 of LIN 2.1)

No diagnostic layer in digital logic (Section 5 of LIN 2.1)

The device is not certified for LIN compliance. Communication baud rate is fixed at 19.2 kBPS.

(2) SCI Mode:

None

6.8 Electrical Characteristics — SPI Interface

PARAMETER	TEST CONDITIONS	MIN	TYP	MAX	UNIT
High-level voltage (\overline{CS} , SCK, SDI, SDO)		3.5			V
Low-level voltage (\overline{CS} , SCK, SDI, SDO)				1.5	V
$C_{L(SDO)}$	Capacitive load for data output (SDO)		10		pF

6.9 Timing Requirements

		MIN	NOM	MAX	UNIT	
POWER SUPPLY						
t_{PU}	Power-up time – AVDD and DVDD reach regulation levels.	VPWR = 7 V to 18 V, VREG is not in regulation		10	ms	
CLOCK						
	External crystal		16		MHz	
F_{OSC}	Internal oscillator frequency	25°C	15.8	16	16.2	MHz
F_{DUTY}	Internal oscillator duty cycle		50%			
	Internal oscillator frequency accuracy	Before LIN sync	-4%	4%		
		LIN baud rate = 19.2 kBPS, after LIN sync	-0.5%	0.5%		
8-bit DAC						
	Settling time	Code 0x00 to 0xFF step. Output is 90% of full scale. $R_{load} = k\Omega$ to GND. $C_{load} = 10\text{ pF}$ to GND		20	μs	
DIAGNOSTICS						
	Low-side driver A/B fault deglitch time	LS_FAULT_TIMER_2 = 1 μs setting		1	μs	
		LS_FAULT_TIMER_2 = 2 μs setting		2	μs	
	Software watchdog time-out			250	ms	

6.10 Timing Requirements — LIN 2.1 Slave and Buffered SCI⁽¹⁾⁽²⁾

Figure 1 shows the LIN timing details.

		MIN	NOM	MAX	UNIT
D1	$T_{H_{Rec(max)}} = 0.744 \times V_{PWR}$; $T_{H_{Dom(max)}} = 0.581 \times V_{PWR}$; $V_{PWR} = 7\text{ V} \dots 18\text{ V}$; $t_{Bit} = 50\ \mu\text{s}$; $D1 = t_{Bus_rec(min)} / (2 \times t_{Bit}) \text{ Load}_1$; $C_{BUS} = 1\text{ nF}$; $R_{BUS} = 1\text{ k}\Omega \text{ Load}_2$; $C_{BUS} = 6.8\text{ nF}$; $R_{BUS} = 660\ \Omega \text{ Load}_3$; $C_{BUS} = 10\text{ nF}$; $R_{BUS} = 500\ \Omega$, see Figure 1.	0.396			
D2	$T_{H_{Rec(min)}} = 0.522 \times V_{PWR}$; $T_{H_{Dom(min)}} = 0.284 \times V_{PWR}$; $V_{PWR} = 7.6\text{ V} \dots 18\text{ V}$; $t_{Bit} = 50\ \mu\text{s}$; $D2 = t_{Bus_rec(max)} / (2 \times t_{Bit}) \text{ Load}_1$; $C_{BUS} = 1\text{ nF}$; $R_{BUS} = 1\text{ k}\Omega \text{ Load}_2$; $C_{BUS} = 6.8\text{ nF}$; $R_{BUS} = 660\ \Omega \text{ Load}_3$; $C_{BUS} = 10\text{ nF}$; $R_{BUS} = 500\ \Omega$, see Figure 1.			0.581	
D3	$T_{H_{Rec(max)}} = 0.778 \times V_{PWR}$; $T_{H_{Dom(max)}} = 0.616 \times V_{PWR}$; $V_{PWR} = 7\text{ V to } 18\text{ V}$; $t_{Bit} = 96\ \mu\text{s}$; $D4 = t_{Bus_rec(min)} / (2 \times t_{Bit}) \text{ Load}_1$; $C_{BUS} = 1\text{ nF}$; $R_{BUS} = 1\text{ k}\Omega \text{ Load}_2$; $C_{BUS} = 6.8\text{ nF}$; $R_{BUS} = 660\ \Omega \text{ Load}_3$; $C_{BUS} = 10\text{ nF}$; $R_{BUS} = 500\ \Omega$, see Figure 1.	0.417			
D4	$T_{H_{Rec(min)}} = 0.389 \times V_{PWR}$; $T_{H_{Dom(min)}} = 0.251 \times V_{PWR}$; $V_{PWR} = 7.6\text{ V to } 18\text{ V}$; $t_{Bit} = 96\ \mu\text{s}$; $D4 = t_{Bus_rec(max)} / (2 \times t_{Bit}) \text{ Load}_1$; $C_{BUS} = 1\text{ nF}$; $R_{BUS} = 1\text{ k}\Omega \text{ Load}_2$; $C_{BUS} = 6.8\text{ nF}$; $R_{BUS} = 660\ \Omega \text{ Load}_3$; $C_{BUS} = 10\text{ nF}$; $R_{BUS} = 500\ \Omega$, see Figure 1.			0.590	
t_{rx_pd}	Propagation delay of receiver $R_{RXD} = 2.4\text{ k}\Omega$; $C_{RXD} = 20\text{ pF}$			6	μs
t_{rx_sym}	Symmetry of receiver propagation delay rising edge with respect to falling edge $R_{RXD} = 2.4\text{ k}\Omega$; $C_{RXD} = 20\text{ pF}$	-2		2	μs

(1) **LIN Mode:**

LIN 2.1 physical layer and LIN protocol (Section 2.1 of LIN 2.1) specification

Exceptions: No wake-up (Section 2.6.2 of LIN 2.1)

No transport layer in digital logic (Section 3 of LIN 2.1)

No node configuration and identification services in digital (Section 4 of LIN 2.1)

No diagnostic layer in digital logic (Section 5 of LIN 2.1)

The device is not certified for LIN compliance. Communication baud rate is fixed at 19.2 kbps.

(2) **SCI Mode:**

None

6.11 Timing Requirements — SPI Interface

Figure 2 shows the SPI clocking details.

		MIN	NOM	MAX	UNIT
f_{SCK}	SPI frequency			8	MHz
$t_{\overline{CS}SCK}$	\overline{CS} low to first SCK rising edge	125			ns
$t_{SCK\overline{CS}}$	Last SCK rising edge to \overline{CS} rising edge	125			ns
$t_{\overline{CS}D}$	\overline{CS} disable time	375			ns
t_{DS}	SDI setup time	25			ns
t_{DH}	SDI hold time	25			ns
t_{SDIS}	SDI fall/rise time			25	ns
t_{SCKR}	SCK rise time			7	ns
t_{SCKF}	SCK fall time			7	ns
t_{SCKH}	SCK high time	62.5			ns
t_{SCKL}	SCK low time	62.5			ns
t_{SDO}	SDO enable time			25	ns
t_{ACCS}	SCK rising edge to SDO data valid			25	ns
t_{SDOD}	SDO disable time			25	ns
t_{SDOS}	SDO rise/fall time	$C_{SDO} = 10 \text{ pF}$, see Figure 2.		15	ns

6.12 Switching Characteristics

over operating free-air temperature range (unless otherwise noted)

PARAMETER	TEST CONDITIONS	MIN	TYP	MAX	UNIT
12-BIT ADC					
Conversion time			1		μs
8051W WARP CORE					
$F_{\text{CORE_CLK}}$ Core frequency			16		MHz
Memory interface			1		Wait State
MEMORY					
OTP programming time	1 byte	100			μs
OTP data retention years	105 °C			10	Years
EEPROM R/W cycles				1000	Cycles
EEPROM data retention	105 °C			10	Years
EEPROM programming time	32 Bytes			70	ms
DIAGNOSTICS					
Main oscillator underfrequency fault				14	MHz
Main oscillator overfrequency fault		18			MHz

6.13 Digital Datapath Filter Switching Characteristics

PARAMETER	TEST CONDITIONS	MIN	TYP	MAX	UNIT
BAND-PASS FILTER					
FILTER TYPE: SECOND-ORDER BUTTERWORTH FILTER					
Band-pass center frequency		40		70	kHz
Band-pass center-frequency step size			0.5		kHz
Bandpass filter bandwidth		4		7	kHz
Bandpass filter bandwidth step size			0.5		kHz
BPF gain			0		dB
DOWNSAMPLE					
Downsample rate		25		50	Samples
Downsample-rate step size			1		

Digital Datapath Filter Switching Characteristics (continued)

PARAMETER	TEST CONDITIONS	MIN	TYP	MAX	UNIT
LOW-PASS FILTER					
FILTER TYPE: FIRST-ORDER BUTTERWORTH FILTER					
LPF cutoff frequency		0.5		4	kHz
LPF cutoff frequency step size			0.5		kHz
LPF gain			0		dB

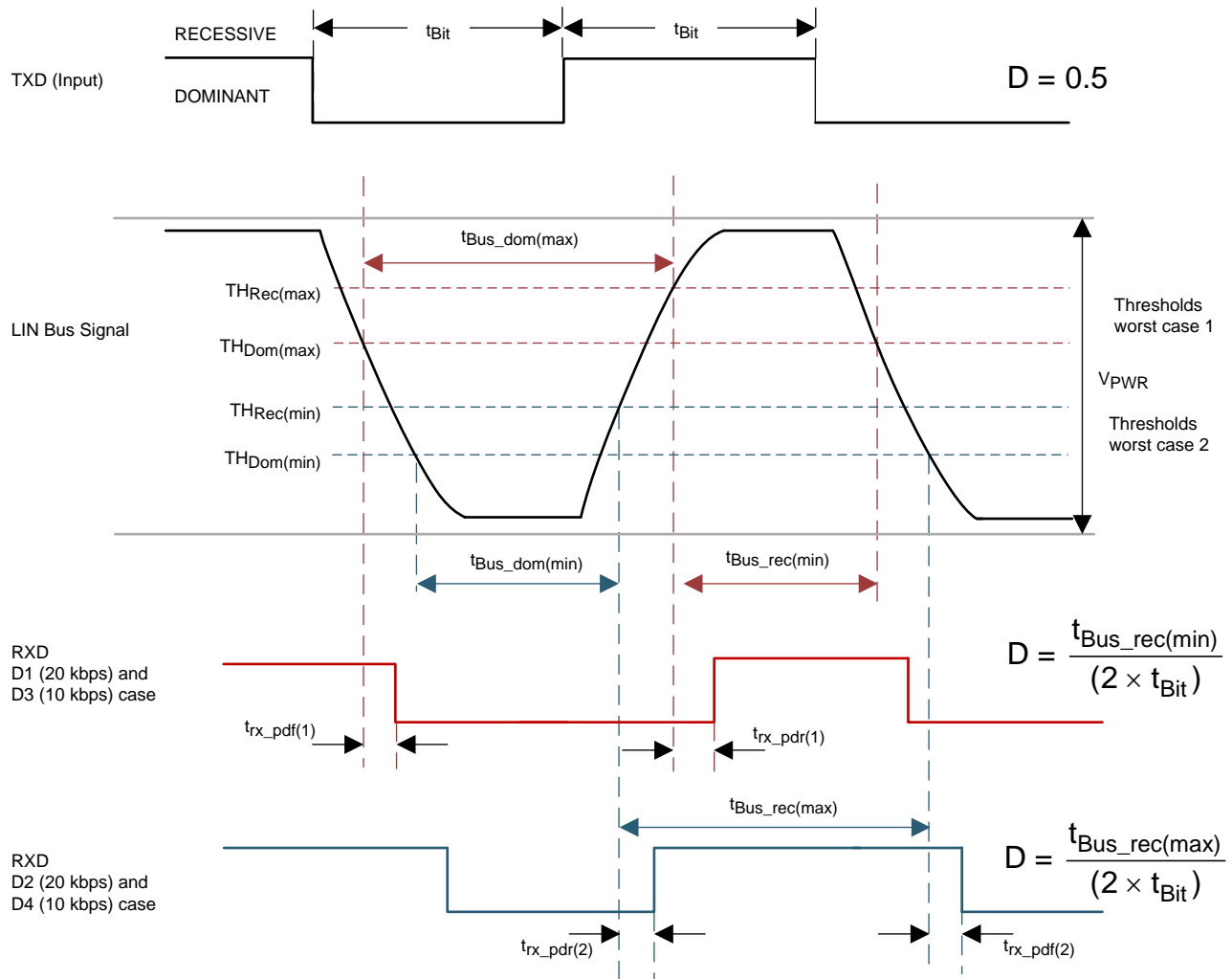

Figure 1. LIN Timing Diagram

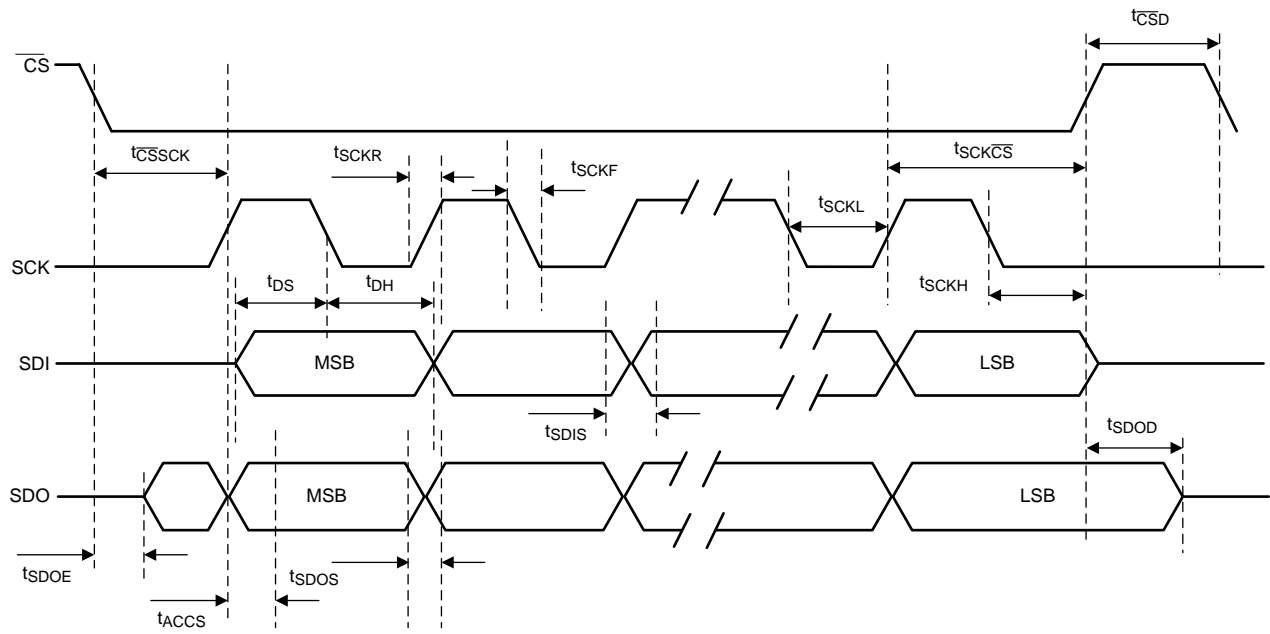

Figure 2. SPI Clcking Details

6.14 Typical Characteristics

VPWR = 12 V, T_A = 25°C

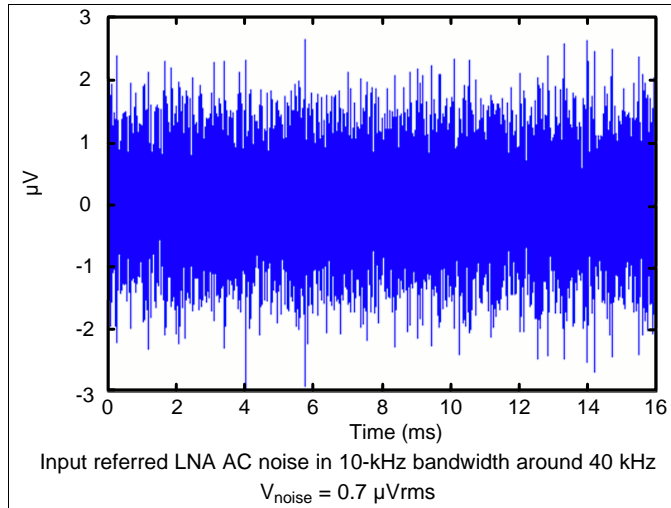

Figure 3. LNA Noise

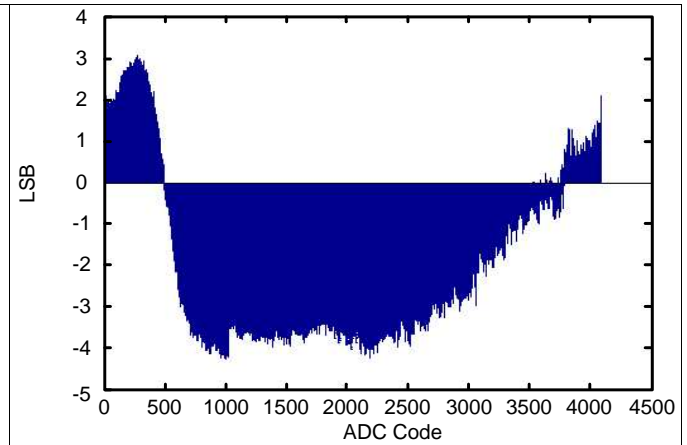

Figure 4. ADC INL

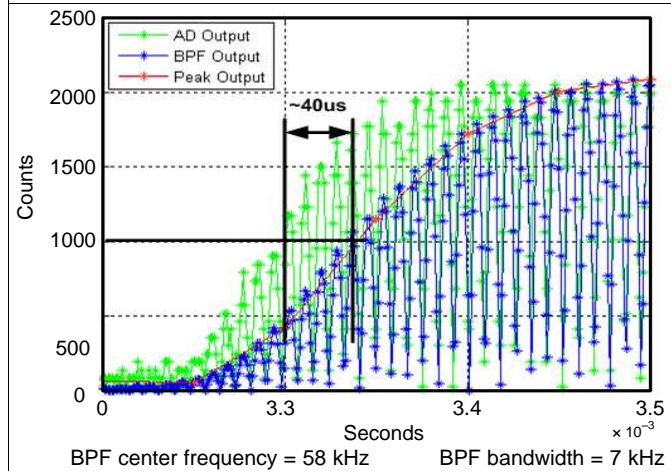

Figure 5. Datapath Output, Downsample Rate = 40

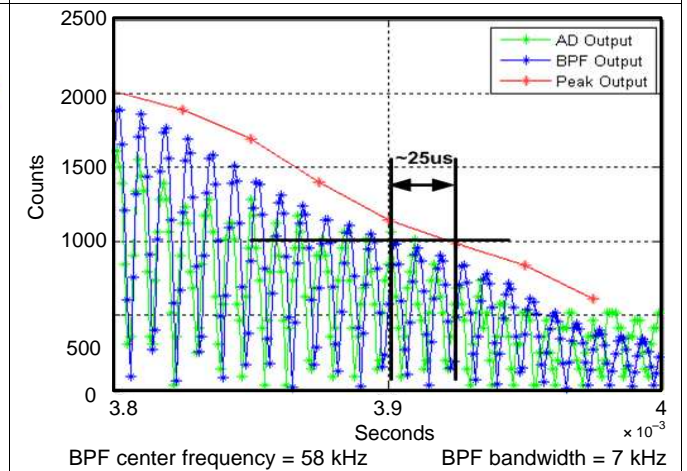

Figure 6. Datapath Output, Downsample Rate = 25

7 Detailed Description

7.1 Overview

The PGA450-Q1 integrates power management, low-side drivers, analog front-end, digital datapath, and interface functions to form a full ultrasonic-sensor signal conditioning solution. The low-side drivers are programmed to drive a specific frequency that matches the external ultrasonic transducer. After transmitting, the same transducer receives the reflected echo signal. The analog front-end filters and amplifies this signal before storing the data in memory. The integrated 8051 microcontroller then processes this data to extract the useful information which typically includes how far away an object is from the transducer. At this point in the process, the information is transmitted through LIN, SCI, or UART.

7.2 Functional Block Diagram

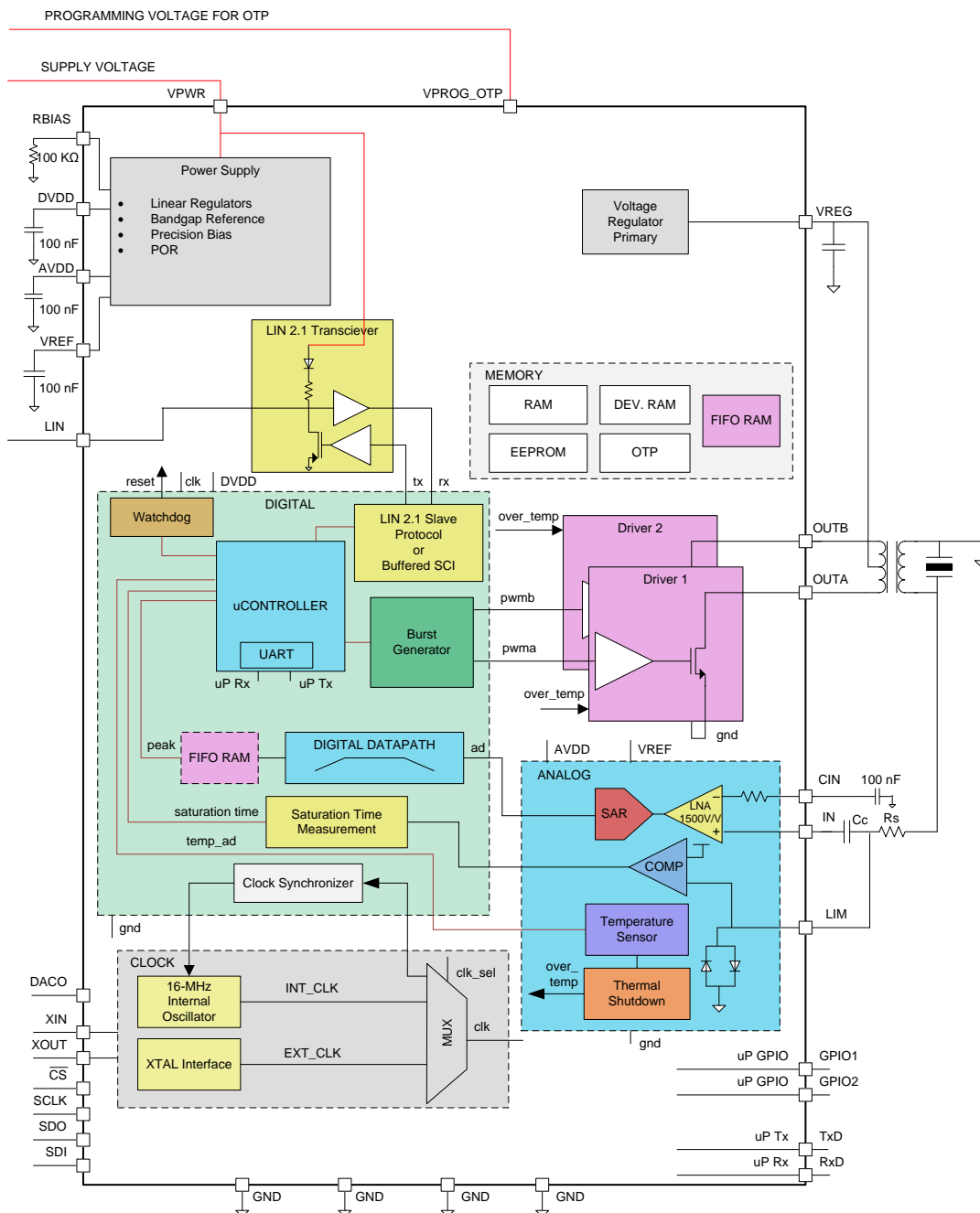

7.3 Feature Description

7.3.1 Power Supply Block

The PGA450-Q1 uses three internal regulators (AVDD, DVDD, and VREF) as supplies for all of the internal circuits. The power-supply block also generates a precision voltage reference, current bias, and internal clock. The internal power-on-reset (POR) signal is released when the internal power supplies, voltage reference, current bias, and internal clock come into regulation.

Figure 7 shows the relationships of the power supplies and the POR signal in the PGA450-Q1 device.

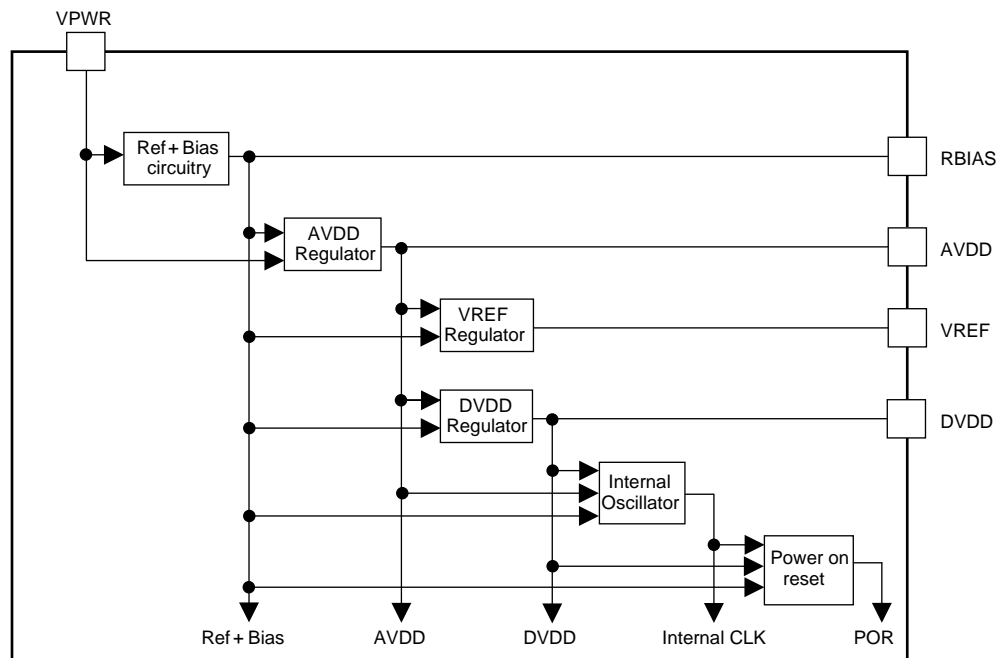
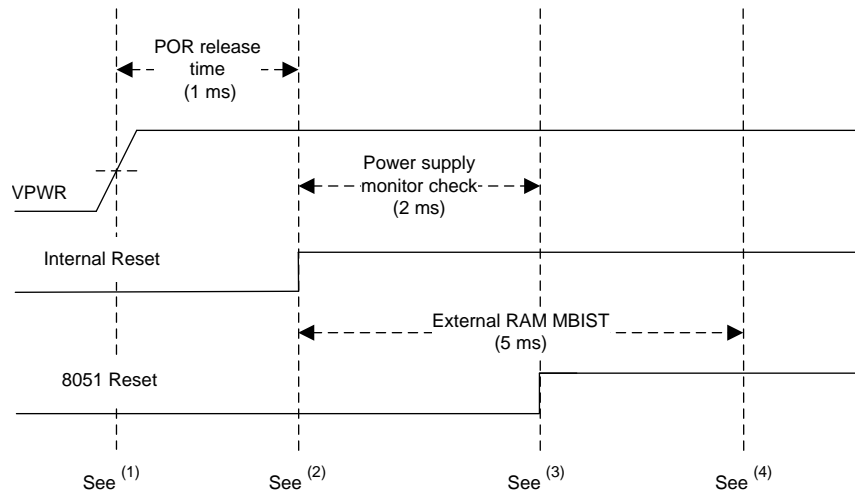

Figure 7. Power-Supply Block

The PGA450-Q1 begins to power up when a voltage is applied to the VPWR pin. Figure 8 shows a typical power-up diagram. The power-up time is typically about 3 ms.

Feature Description (continued)

- (1) The VPWR ramp reaches POR level.
- (2) The internal reset to the digital core is released and EXTERNAL RAM MBIST is initiated. SPI communication is available.
- (3) 8051W reset is deasserted. Software starts execution.
- (4) EXTERNAL RAM MBIST is complete. External Scratchpad RAM and FIFO RAM available for use.

Figure 8. Power-Up Waveforms

The PGA450-Q1 provides two power-control bits for enabling different analog blocks to manage the total current consumption of the device. On power up, the device is in the *QUIET* mode with only the 8051W and LIN transceiver turned on. All other analog blocks are disabled. Setting the ACTIVE_EN bit enables the low-side drivers required for bursting as well as the echo-processing circuitry that includes the LNA and the ADC. In addition, a separate control bit, VREG_EN, is provided to enable the VREG circuitry, which is used to charge the external capacitor used during bursting.

The AVDD pin can be used to source current for up to 5 mA for resistive loads, including the loads on the GPIO and Tx pins.

Table 1. Power Modes

CONTROL BIT		DEFAULT	FUNCTION
1	VREG_EN	Disabled	Enables the VREG circuitry that provides the 100-mA current to charge the external capacitor used during bursting
2	ACTIVE_EN ⁽¹⁾	Disabled	Enables the LNA, ADC, ADC REF, and other support circuitry related to burst generation and echo processing

(1) ACTIVE_EN bit must be set before enabling the burst / saturation or echo-enable bits.

7.3.2 VREG

The PGA450-Q1 provides a regulated voltage output which, along with an external capacitor, can be used to drive the primary of the transformer used to excite the transducer. The VREG regulator provides a 100-mA current, sourced from VPWR, to charge the external capacitor. The user can select the desired VREG voltage by setting the VREG_SEL register to the appropriate value.

For VREG to be regulated to the selected voltage, VPWR must be at least 2 V above the selected VREG voltage.

The energy required for the burst comes from the external capacitor. The device has a VREG_READY status bit in the STATUS2 register to indicate when the capacitor is fully charged and has reached the regulation voltage.

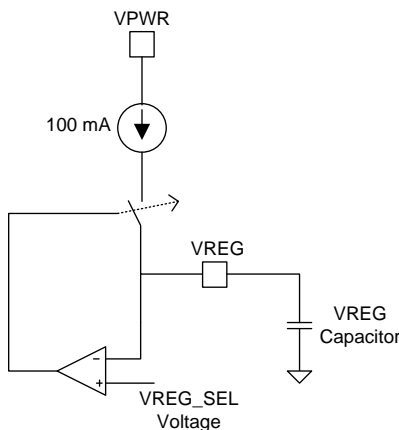

Figure 9. VREG Regulator

This block is disabled by default. Setting the VREG_EN bit in the PWR_MODE register to high, enables this regulator.

7.3.3 Clock

The clock block generates the system clock that is used in the generation of burst, communication, echo time measurement, and the microprocessor clock. Figure 10 shows the clock block in the PGA450-Q1.

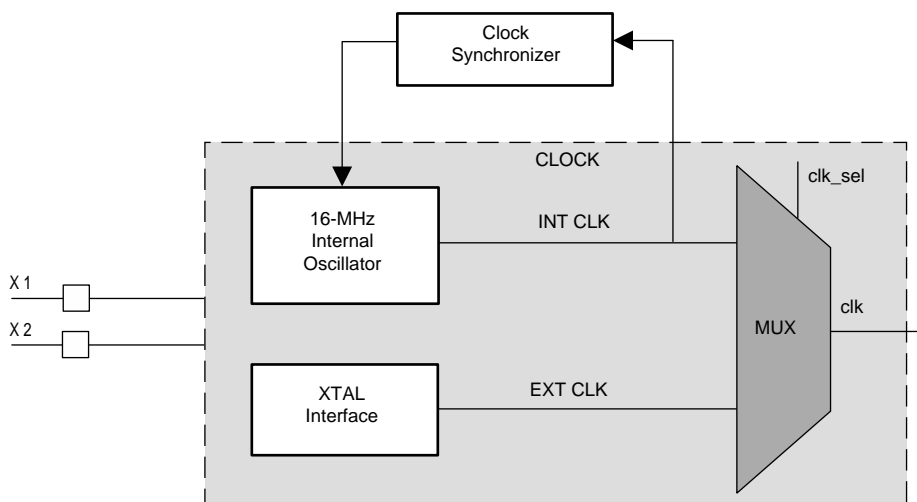

Figure 10. Clock Block in PGA450-Q1

The CLK signal provided to various blocks inside the device is derived from one of the following sources:

1. Internal oscillator without synchronization with communication: in this mode, the internal oscillator output is the source for the system clock.
2. Internal oscillator with synchronization with communication: in this mode, the internal oscillator output is *corrected* for inaccuracy using time measurements of the communication bus. This mode requires the implementation of *CLOCK SYNCHRONIZER* logic in the digital control block. The clock synchronizer uses the *SYNC FIELD* to measure the timer value and adjust the internal oscillator output.
3. External crystal: in this mode, a 16-MHz external crystal is the source of the system clock.

The clock source is controlled by the CLK_SEL register. Table 2 lists the settings of the CLK_SEL bits and the corresponding clock mode.

Table 2. Clock Selection

CLK_SEL BIT VALUES	CLOCK SOURCE
0b00	Internal clock. Ignore the synchronization pulse received on the LIN bus.
0b01	Internal clock. Process the synchronization pulse received on the LIN bus.
0b10	External crystal clock
0b11	Internal clock. Ignore the synchronization pulse received on the LIN bus.

7.3.3.1 Clock Synchronizer Using the SYNC Field in the LIN Bus

The clock synchronizer block adjusts the internal oscillator based on a SYNC field in the LIN frame received in the communication line. The internal clock is trimmed to 16 MHz with $\pm 4\%$ tolerance in the TI factory.

The clock synchronizer improves the instantaneous accuracy of the internal oscillator frequency to 16 MHz $\pm 0.5\%$ using the LIN SYNC field, assuming an ideal LIN baud rate of 19.2 kbps. The synchronization algorithm uses the time between two falling edges of the LIN SYNC field to adjust the internal oscillator.

The SYNC_COUNT is available for the 8051W to determine the effectiveness of the synchronization process based on the LIN SYNC field. That is, if the synchronization was effective, then the SYNC COUNT value should be close to 1667 ± 8 counts.

This OSC SYNC value can also be updated by the 8051W microprocessor by setting the OVR bit in OSC_SYNC_CTRL ESFR.

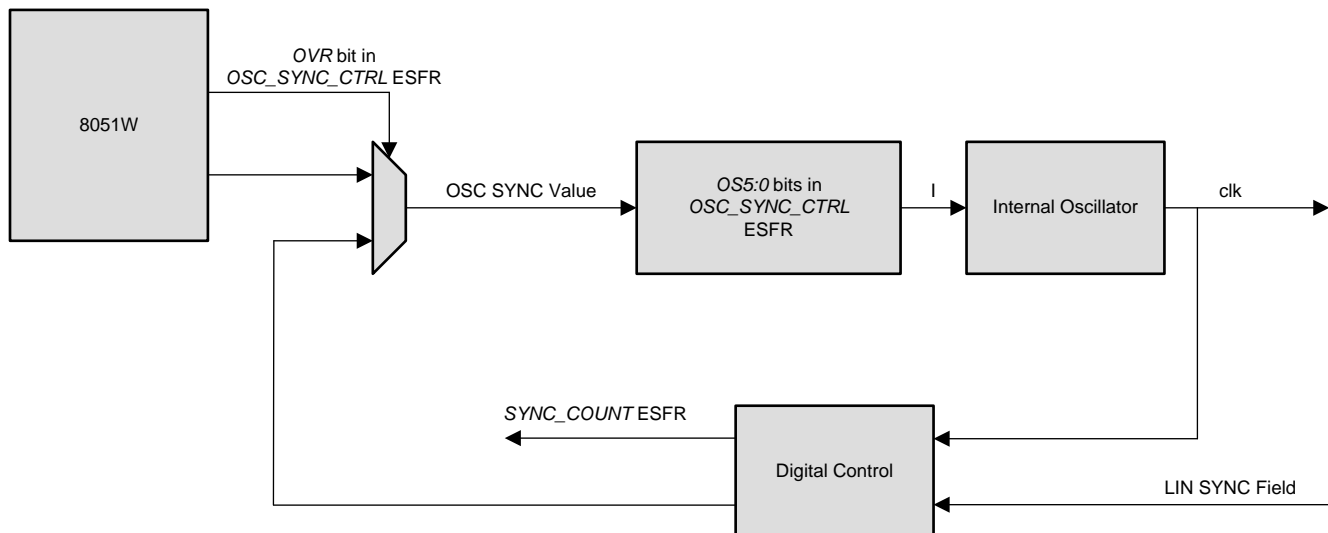

Figure 11. PGA450-Q1 Internal Clock Synchronization Control

Table 3 lists the value of OS<5:0> and the resulting change in frequency.

Table 3. OS<5:0> versus Delta System Clock Frequency

OS<5:0>	Delta Frequency
0	-3.84 MHz
..	..
31	-120 kHz
32	0 kHz
33	120 kHz
..	..
63	3.72 MHz

NOTE

The clock synchronization feature is not available if the device is configured in SCI buffered mode. See the [LIN 2.1 Slave and Buffered SCI](#) section for details.

7.3.4 Low-Side Drive FETs

The PGA450-Q1 provides two low-side drivers for driving the primary of a transformer or an equivalent load. The [Burst Generator](#) section describes the control and drive modes for the low-side drive.

The low-driver block also has diagnostics. See the [Diagnostics](#) section for a description of the diagnostics.

Figure 12 shows the schematic of the low-side drive

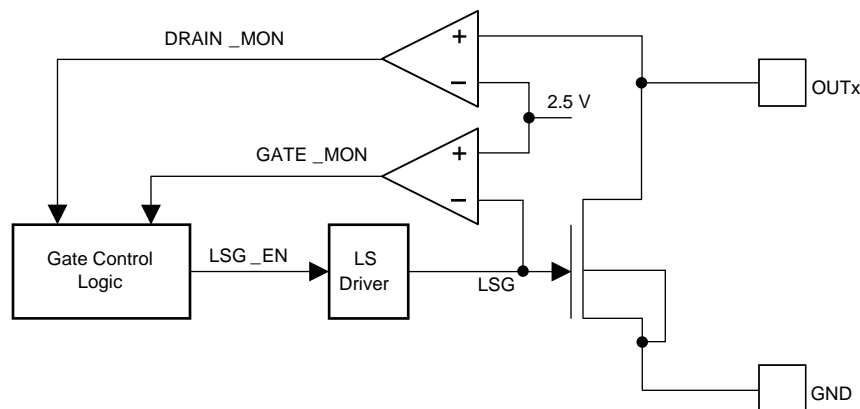

Figure 12. Low-Side Drive Block Diagram

7.3.5 Burst Generator

The burst generator block generates the high-frequency pulses used to drive the gates of the low-side FETs. The low-side FETs ultimately drive the transducer by modulating the primary of the transformer.

The PGA450-Q1 provides mode bits in the BURST MODE register (see the [Burst Mode Register \(offset = 0xB3\) \[reset = 0\]](#) section) to configure each low-side drive MOSFET in three possible drive modes.

The three possible drive modes are:

Single-ended: In this mode, one low-side switch is used to turn current on and off in the primary of the transformer. The rate of change of current in the primary generates a voltage in the secondary of the transformer, which is connected to the transducer.

Push-pull: In this mode, two low-side switches are used to turn current on and off in two primary coils in the transformer. The primary coils have the same number of turns. The rate of change of current in the primary generates a voltage in the secondary of the transformer, which is connected to the transducer. The direction of current in the primary coils generates voltages of opposite polarity in the secondary, effectively doubling the peak-to-peak voltage in the secondary.

8051W port drive: In this mode, the low-side switches are controlled through the an 8051W port pin.

Figure 13 shows the block diagram of the burst generator. The figure shows that the burst generator has a number of registers which the user software must configure.

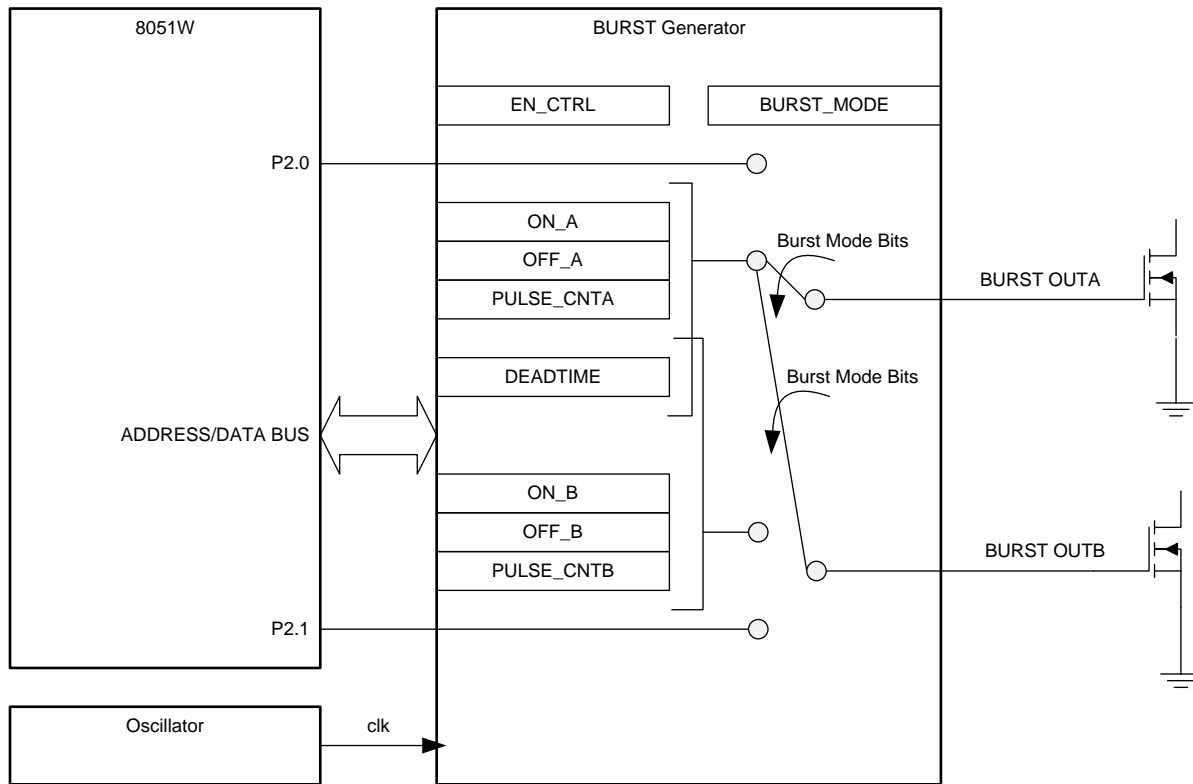

Figure 13. Burst Generator

The PGA450-Q1 provides 3 mode bits in the BURST MODE register to select from the five burst configurations available. Table 4 lists the modes of operation of the two low-side gate drives of the burst generator. For an understanding of the configurations, see Figure 14 and for an understanding of the waveforms, see Figure 15.

Table 4. Low-Side MOSFET Gate Drive Modes

ITEM	DESCRIPTION
Mode Bits in BURST_MODE Register: 000	
Mode description	Low-side A and B are in push-pull
Low-side A trigger	Write 1 to BURST_A_EN bit in EN_CTRL register
Low-side B trigger	Write 1 to BURST_A_EN bit in EN_CTRL register
No. of pulses on A	Set by PULSE_CNTA (0–63 pulses) register
No. of pulses on B	Set by PULSE_CNTB (0–63 pulses) register
Low-side A frequency	Set by registers: <ul style="list-style-type: none"> • ON_A (11 bits at 16 MHz) • OFF_A (11 bits at 16 MHz) • DEADTIME (8 bits at 16 MHz)
Low-side B frequency	Set by registers: ON_A (11 bits at 16 MHz), OFF_A (11 bits at 16 MHz), DEADTIME (8 bits at 16 MHz)
Mode Bits in BURST_MODE Register: 001	
Mode description	Low-side A is controlled by burst generator A Low-side B through the internal micro P2.1 port
Low-side A trigger	Write 1 to BURST_A_EN bit in EN_CTRL register
Low-side B trigger	Controlled by 8051W software
No. of pulses on A	Set by PULSE_CNTA (0–63 pulses) register
No. of pulses on B	Controlled by 8051W software

Table 4. Low-Side MOSFET Gate Drive Modes (continued)

ITEM	DESCRIPTION
Low-side A frequency	Set by registers: • ON_A (11 bits at 16 MHz) • OFF_A (11 bits at 16 MHz)
Low-side B frequency	Controlled by 8051W software
Mode Bits in BURST_MODE Register: 010	
Mode description	Low-side A through the internal micro P2.0 port Low-side B is controlled by burst generator B
Low-side A trigger	Controlled by 8051W software
Low-side B trigger	Write 1 to BURST_B_EN bit in EN_CTRL register
No. of pulses on A	Controlled by 8051W software
No. of pulses on B	Set by PULSE_CNTB (0–63 pulses) register
Low-side A frequency	Controlled by 8051W software
Low-side B frequency	Set by registers: ON_B (11 bits at 16 MHz) and OFF_B (11 bits at 16 MHz)
Mode Bits in BURST_MODE Register: 011	
Mode description	Low-side A is controlled by burst generator A Low-side B is controlled by burst generator B
Low-side A trigger	Write 1 to BURST_A_EN bit in EN_CTRL register
Low-Side B trigger	Write 1 to BURST_B_EN bit in EN_CTRL register
No. of pulses on A	Set by PULSE_CNTA (0–63 pulses) register
No. of pulses on B	Set by PULSE_CNTB (0–63 pulses) register
Low-side A frequency	Set by registers: ON_A (11 bits at 16 MHz) and OFF_A (11 bits at 16 MHz)
Low-side B frequency	Set by registers: ON_B (11 bits at 16 MHz) and OFF_B (11 bits at 16 MHz)
Mode Bits in BURST_MODE Register: 100	
Mode description	Low-side A through the internal micro P2.0 port Low-side B through the internal micro P2.1 port
Low-side A trigger	Controlled by 8051W software
Low-side B trigger	Controlled by 8051W software
No. of pulses on A	Controlled by 8051W software
No. of pulses on B	Controlled by 8051W software
Low-side A frequency	Controlled by 8051W software
Low-side B frequency	Controlled by 8051W software
Mode Bits in BURST_MODE Register: 101	
Mode description	Reserved
Mode Bits in BURST_MODE Register: 110	
Mode description	Reserved
Mode Bits in BURST_MODE Register: 111	
Mode description	Reserved

Figure 14 shows the relationship of BURST_OUTx.

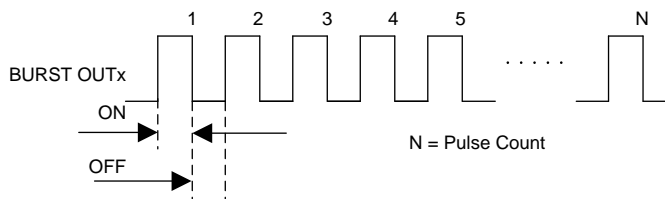

Figure 14. Timing Diagram Showing the Usage of ON Register, OFF Register and PULSE COUNT Register Values

The relationship between the ONTIME, OFFTIME, and DEADTIME values in the push-pull configurations are shown in Figure 15.

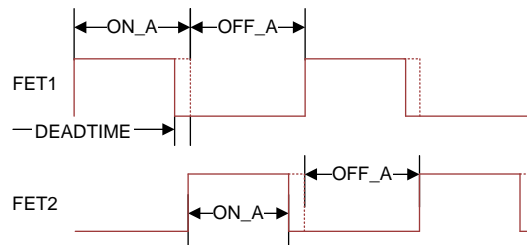

Figure 15. Timing Diagram Showing the Relationship Between ONTIME, OFFTIME, and DEADTIME Registers in the Push-Pull Configuration

Table 5 lists the 8051W port pins used to drive the OUTA and OUTB pins are listed in the 8051W drive mode.

Table 5. OUTA/OUTB Pin Map

PGA450-Q1 PIN	8051W PORT
OUTA	2.0
OUTB	2.1

7.3.6 Low-Noise Amplifier

This block is the analog front-end that interfaces with the transducer directly. The echo signal is coupled through an external capacitor so that only the AC component of the transducer voltage is passed to the low-noise amplifier (LNA). The LNA outputs an amplified version of the transducer voltage with a DC offset that is equal to the mid-scale of the analog-to-digital converter (ADC).

The LNA gain is configurable by setting the LNA_GAIN1 and LNA_GAIN0 bits in the CONTROL_1 register to the appropriate values.

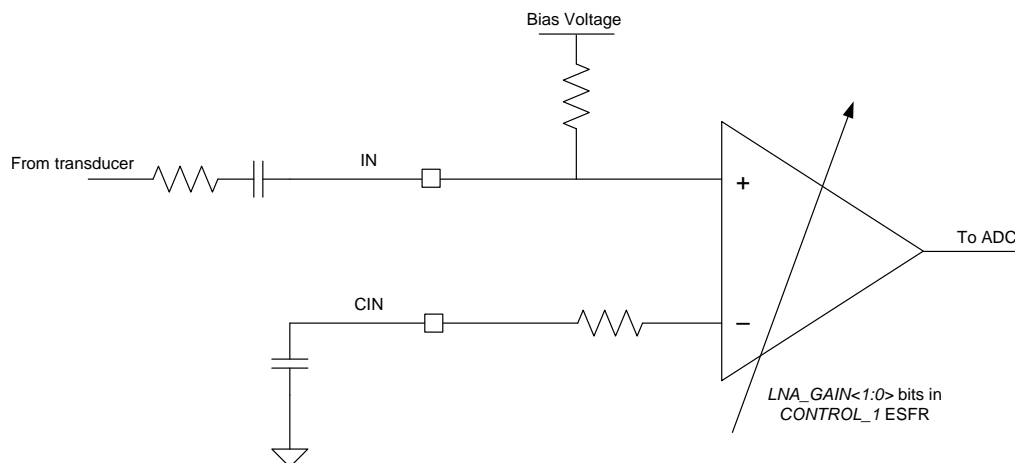

Figure 16. Low-Noise Amplifier

7.3.7 Analog-to-Digital Converter

The 12-bit successive approximation register (SAR) analog-to-digital converter converts the analog voltage from the echo-processing circuit into a digital word. The converted digital word is processed by the bandpass filter. The ADC is dedicated to the echo-processing signal path and is only enabled in active mode.

7.3.8 Digital Data Path

The digital datapath processes the AD sample to extract the peak profile of the echo. The output of the digital datapath is stored in the FIFO RAM.

Figure 17 shows the digital datapath.

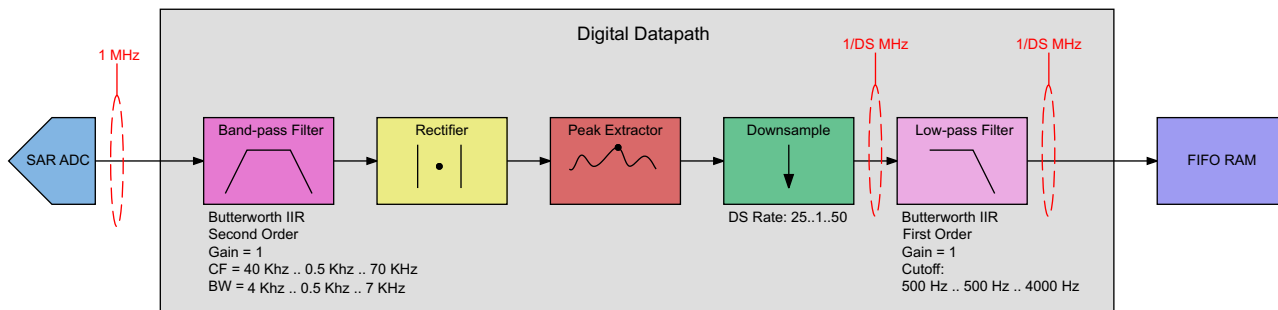

Figure 17. Digital Data Path

The digital datapath has the following components:

- Bandpass filter
- Rectifier
- Peak extractor
- Downsampler
- Low-pass filter

Each of the digital datapath components is described in the following subsections.

7.3.8.1 Bandpass Filter (BPF)

The echo signal is an amplitude-modulated signal with the underlying carrier frequency equal to the drive frequency of the ultrasonic transducer. The bandpass filter block allows frequencies near the drive frequency to pass to downstream signal blocks.

The bandpass filter is a second-order Butterworth IIR filter. The user can configure the center frequency and the bandwidth of the filter by writing specific values to coefficient registers BPF_B1, BPF_A2, and BPF_A3.

Table 7 lists the values (in hex) that must be written to the coefficient registers to realize a bandpass filter of specific center frequency and bandwidth (or Q).

NOTE

The stability of the filter is not assured if values other than those listed in Table 7 are written to the registers.

Table 6. Bandpass Filter Coefficient Values

BW (kHz)	B1 (Hex)	A3 (Hex)
4	32D	F9A5
4.5	392	F8DD
5	3F6	F815
5.5	459	F74D
6	4BD	F687
6.5	520	F5C1
7	582	F4FB

Table 7. Bandpass Filter Coefficient Values

CF (kHz)	BW (kHz)	A2 (Hex)
39	4	F54A
	5	F48B
	6	F3CD
	7	F311
40	4	F4E6
	5	F427
	6	F36A
	7	F2AE
41	4	F480
	5	F3C1
	6	F304
	7	F249
42	4	F417
	5	F358
	6	F29C
	7	F1E1
43	4	F3AC
	5	F2ED
	6	F231
	7	F176
44	4	F33E
	5	F280
	6	F1C4
	7	F10A
45	4	F2CE
	5	F210
	6	F154
	7	F09A
46	4	F25B
	5	F19E
	6	F0E2
	7	F029
47	4	F1E6
	5	F129
	6	F06E
	7	EFB5
48	4	F16E
	5	F0B2
	6	EFF7
	7	EF3E
49	4	F0F4
	5	F038
	6	EF7E
	7	EEC5

Table 7. Bandpass Filter Coefficient Values (continued)

CF (kHz)	BW (kHz)	A2 (Hex)
50	4	F078
	5	EFBC
	6	EF02
	7	EE4A
51	4	EFF9
	5	EF3E
	6	EE84
	7	EDCC
52	4	EF78
	5	EEBD
	6	EE03
	7	ED4C
53	4	EEF4
	5	EE39
	6	ED80
	7	ECC9
54	4	EE6E
	5	EDB4
	6	ECFB
	7	EC44
55	4	EDE5
	5	ED2B
	6	EC73
	7	EBBD
56	4	ED5A
	5	ECA1
	6	EBE9
	7	EB33
57	4	ECCD
	5	EC14
	6	EB5D
	7	EAA7
58	4	EC3D
	5	EB85
	6	EACE
	7	EA19
59	4	EBAB
	5	EAF3
	6	EA3D
	7	E988
60	4	EB16
	5	EA5F
	6	E9A9
	7	E8F5

Table 7. Bandpass Filter Coefficient Values (continued)

CF (kHz)	BW (kHz)	A2 (Hex)
61	4	EA7F
	5	E9C8
	6	E913
	7	E85F
62	4	E9E6
	5	E930
	6	E87B
	7	E7C7
63	4	E94B
	5	E894
	6	E7E0
	7	E72D
64	4	E8AD
	5	E7F7
	6	E743
	7	E691
65	4	E80C
	5	E757
	6	E6A4
	7	E5F2
66	4	E769
	5	E6B5
	6	E602
	7	E551
67	4	E6C4
	5	E610
	6	E55E
	7	E4AD
68	4	E61D
	5	E569
	6	E4B8
	7	E407
69	4	E573
	5	E4C0
	6	E40F
	7	E35F
70	4	E4C7
	5	E415
	6	E364
	7	E2B5

7.3.8.2 Rectifier

The output of the bandpass filter is a signed number. The rectifier rectifies the output of the bandpass filter to create a positive number.

7.3.8.3 Peak Extractor

The peak extractor in the PGA450-Q1 is a simple moving-peak algorithm. Specifically, the output of the peak extractor is updated if the input to the peak extractor is greater than the previous output of the peak extractor. This algorithm is summarized in Equation 1.

$$y[k] = \{y[k - 1], \text{ if } y[k - 1] > x[k], \text{ otherwise } x[k]\}$$

where

- y is the output of the peak extractor
- x is the input to the peak extractor
- k is the discrete-time step

(1)

Figure 18 shows the peak extractor algorithm.

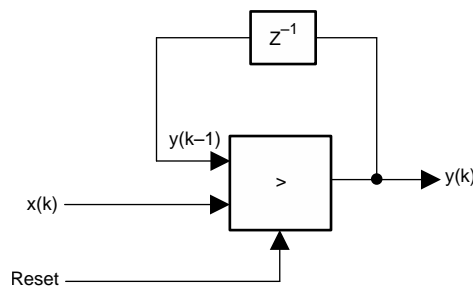

Figure 18. Peak Extractor

7.3.8.4 Downsample

The downsample block performs two functions:

- Generates the reset signal for the peak extractor shown in Figure 18.
- Generates the output.

The downsample rate can be configured by the user by writing to the downsample register. If the output of the peak extractor must be low-pass filtered before storing it in the FIFO, then the allowable values for the downsample register for the low-pass filter correctly are from 25 to 50; that is:

$$25 \leq \text{DOWNSAMPLE} \leq 50$$

However, if the user does not need to low-pass filter the output before storing to the FIFO, then the user can configure the DOWNSAMPLE register value to any value between 1 and 63.

The downsample block has a counter which starts at 0 and counts up to the values programmed in the DOWNSAMPLE register. When the count reaches the value in the DOWNSAMPLE register, the counter inside the downsample block is reset to 0. Furthermore, the downsample block generates a reset to the peak extractor. This reset signal sets the output of the peak extractor to 0.

The data output rate of the downsample block is:

$$\text{OUTPUT RATE OF DOWNSAMPLE RATE} = \text{DOWNSAMPLE} \times 1 \mu\text{s.}$$

7.3.8.5 Low-Pass Filter

The output of the downsample block can be filtered by a low-pass filter. The low-pass filter in the PGA450-Q1 device is a first-order Butterworth IIR filter with a configurable cutoff frequency.

The user can configure the cutoff frequency of the filter by writing specific values to coefficient registers LPF_B1 and LPF_A2. Note that for the same desired cutoff frequency, the coefficient values depend on the configured DOWNSAMPLE register.

Table 8 lists the values (in hex) that must be written to the coefficient registers to realize a low-pass filter of a specific cutoff frequency. The stability of the filter is not assured if values other than those listed in the table are written to the registers.

Table 8. Low-Pass Filter Coefficient Values

CUTOFF (kHz)	DOWNSAMPLE (Hex)	B1 (Hex)	A2 (Hex)
0.5	19	4D7	7652
	1A	506	75F3
	1B	536	7594
	1C	565	7535
	1D	595	74D7
	1E	5C4	7479
	1F	5F3	741B
	20	622	73BD
	21	650	7360
	22	67F	7302
	23	6AD	72A5
	24	6DC	7249
	25	70A	71EC
	26	738	7190
	27	766	7134
	28	794	70D9
	29	7C1	707E
	2A	7EF	7022
	2B	81C	6FC8
	2C	84A	6F6D
	2D	877	6F13
	2E	8A4	6EB9
	2F	8D1	6E5F
	30	8FD	6E05
	31	92A	6DAC
	32	957	6D53

Table 8. Low-Pass Filter Coefficient Values (continued)

CUTOFF (kHz)	DOWNSAMPLE (Hex)	B1 (Hex)	A2 (Hex)
1.0	19	957	6D53
	1A	9B0	6CA1
	1B	A08	6BF0
	1C	A60	6B41
	1D	AB7	6A92
	1E	B0E	69E5
	1F	B64	6937
	20	BBA	688B
	21	C10	67E0
	22	C65	6736
	23	CBA	668C
	24	D0E	65E4
	25	D62	653C
	26	DB6	6495
	27	E09	63EF
	28	E5B	6349
	29	EAE	62A5
	2A	EFF	6201
	2B	F51	615E
	2C	FA2	60BC
	2D	FF3	601B
	2E	1043	5F7A
	2F	1093	5EDA
	30	10E2	5E3B
	31	1132	5D9D
	32	1180	5CFF

Table 8. Low-Pass Filter Coefficient Values (continued)

CUTOFF (kHz)	DOWNSAMPLE (Hex)	B1 (Hex)	A2 (Hex)
1.5	19	D8C	64E8
	1A	E09	63EF
	1B	E84	62F7
	1C	EFF	6201
	1D	F79	610D
	1E	FF3	601B
	1F	106B	5F2A
	20	1000	5E3B
	21	1159	5D4E
	22	11CF	5C62
	23	1244	5B78
	24	12B8	5A90
	25	132C	59A9
	26	139E	58C4
	27	1410	57E0
	28	1481	56FD
	29	14F2	561C
	2A	1562	553D
	2B	15D1	545E
	2C	163F	5381
	2D	16AD	52A6
	2E	171A	51CC
	2F	1786	50F3
	30	17F2	501C
	31	185D	4F45
	32	18C8	4E70

Table 8. Low-Pass Filter Coefficient Values (continued)

CUTOFF (kHz)	DOWNSAMPLE (Hex)	B1 (Hex)	A2 (Hex)
2.0	19	1180	5CFF
	1A	121D	5BC6
	1B	12B8	5A90
	1C	1352	595C
	1D	13EA	582B
	1E	1481	56FD
	1F	1517	55D1
	20	15AC	54A8
	21	163F	5381
	22	16D1	525D
	23	1762	513B
	24	17F2	501C
	25	1881	4EFE
	26	190F	4DE3
	27	199B	4CCA
	28	1A27	4BB3
	29	1AB1	4A9E
	2A	1B3A	498B
	2B	1BC3	487A
	2C	1C4A	476B
	2D	1CD1	465E
	2E	1D56	4553
	2F	1DDB	444A
	30	1E5F	4342
	31	1EE2	423C
	32	1F64	4138

Table 8. Low-Pass Filter Coefficient Values (continued)

CUTOFF (kHz)	DOWNSAMPLE (Hex)	B1 (Hex)	A2 (Hex)
2.5	19	153D	5587
	1A	15F6	5415
	1B	16AD	52A6
	1C	1762	513B
	1D	1816	4FD4
	1E	18C8	4E70
	1F	1978	4D10
	20	1A27	4BB3
	21	1AD3	4A59
	22	1B7F	4903
	23	1C29	47AF
	24	1CD1	465E
	25	1D78	4511
	26	1E1D	43C6
	27	1EC1	427E
	28	1F64	4138
	29	2005	3FF5
	2A	20A6	3EB5
	2B	2145	3D77
	2C	21E2	3C3B
	2D	227F	3B02
	2E	231A	39CB
	2F	23B5	3897
	30	244E	3764
	31	24E6	3633
	32	257E	3505

Table 8. Low-Pass Filter Coefficient Values (continued)

CUTOFF (kHz)	DOWNSAMPLE (Hex)	B1 (Hex)	A2 (Hex)
3.0	19	18C8	4E70
	1A	199B	4CCA
	1B	1A6C	4B28
	1C	1B3A	498B
	1D	1C07	47F3
	1E	1CD1	465E
	1F	1D99	44CE
	20	1E5F	4342
	21	1F23	41BA
	22	1FE5	4036
	23	20A6	3EB5
	24	2164	3D38
	25	2221	3BBE
	26	22DC	3A47
	27	2396	38D4
	28	244E	3764
	29	2505	35F7
	2A	25BA	348D
	2B	266E	3325
	2C	2720	31C0
	2D	27D1	305E
	2E	2881	2EFE
	2F	292F	2DA1
	30	29DD	2C46
	31	2A89	2AED
	32	2B35	2997

Table 8. Low-Pass Filter Coefficient Values (continued)

CUTOFF (kHz)	DOWNSAMPLE (Hex)	B1 (Hex)	A2 (Hex)
3.5	19	1C29	47AF
	1A	1D14	45D9
	1B	1DFC	4408
	1C	1EE2	423C
	1D	1FC5	4076
	1E	20A6	3EB5
	1F	2184	3CF8
	20	2260	3B41
	21	2339	398D
	22	2411	37DE
	23	24E6	3633
	24	25BA	348D
	25	268B	32E9
	26	275B	314A
	27	2829	2FAE
	28	28F5	2E15
	29	29C0	2C80
	2A	2A89	2AED
	2B	2B51	295E
	2C	2C17	27D2
	2D	2CDC	2648
	2E	2DA0	24C0
	2F	2E62	233C
	30	2F23	21B9
	31	2FE4	2039
	32	30A3	1EBB

Table 8. Low-Pass Filter Coefficient Values (continued)

CUTOFF (kHz)	DOWNSAMPLE (Hex)	B1 (Hex)	A2 (Hex)
4.0	19	1F64	4138
	1A	2066	3F35
	1B	2164	3D38
	1C	2260	3B41
	1D	2358	3950
	1E	244E	3764
	1F	2541	357E
	20	2632	339D
	21	2720	31C0
	22	280C	2FE8
	23	28F5	2E15
	24	29DD	2C46
	25	2AC2	2A7B
	26	2BA6	28B4
	27	2C88	26F0
	28	2D68	2530
	29	2E46	2373
	2A	2F23	21B9
	2B	2FFF	2002
	2C	30D9	1E4E
	2D	31B2	1C9D
	2E	3289	1AED
	2F	3360	1940
	30	3435	1796
	31	350A	15ED
	32	35DD	1446

7.3.8.6 Datapath Output Format Control

The output of the datapath is stored in the ECHO DATA register. The output of the datapath register is updated at the rate determined by the value in the DOWNSAMPLE register.

The output of the digital datapath is also stored in the FIFO RAM. The user can configure the data stored in the FIFO RAM by writing values to the mode bits in the FIFO control (FIFO_CTRL) register.

Table 9 lists the output format of the digital datapath that is stored in the FIFO.

Table 9. Digital Datapath Output Format

MODE BITS	OUTPUT FORMAT	DESCRIPTION
0b00	12 bits	All 12 bits of the digital datapath output are stored in the FIFO. Note that storing 12 bits consumes 2 bytes of the FIFO RAM.
0b01	8 most-significant bits	The upper 8 bits of the 12-bit digital datapath output are stored in the FIFO.
0b10	8 least-significant bits	The lower 8 bits of the 12-bit digital datapath output are stored in the FIFO, if all the upper 4 bits of the digital datapath output are 0s. However, if one of the upper 4 bits of the digital datapath is 1, then 0xFF is stored to the FIFO.
0b11	8 middle bits	Bits 10 through 3 of the 12-bit digital datapath output are stored in the FIFO, if the upper 2 bits of the digital datapath output are 0s. However, if one of the upper 2 bits of the digital datapath is 1, then 0xFF is stored to the FIFO.

7.3.8.7 Datapath Activation and Blanking Timer

The digital datapath calculations can be enabled or disabled using the ECHO_EN bit in the enable control (EN_CTRL) register. When the ECHO_EN bit is set to 0, the digital datapath is disabled; that is, the datapath does not perform the calculations and does not update the FIFO RAM. Furthermore, the history of the band-pass and low-pass filters is reset to 0.

When the user sets ECHO_EN to 1, the digital datapath begins the computation. However, the output of the datapath does not immediately start filling the FIFO RAM. Rather, the output of the digital datapath is updated into the FIFO RAM when the user-configured BLANKING_TIMER value has expired.

The user-configurable BLANKING_TIMER register is an 8-bit-register with 16- μ s resolution per bit. In other words, the user can set the blanking timer value from 0 μ s to 4.08 ms in steps of 16 μ s.

Figure 19 shows the state of the digital datapath based on the enable or disable state of ECHO_EN and the BLANKING_TIMER register value.

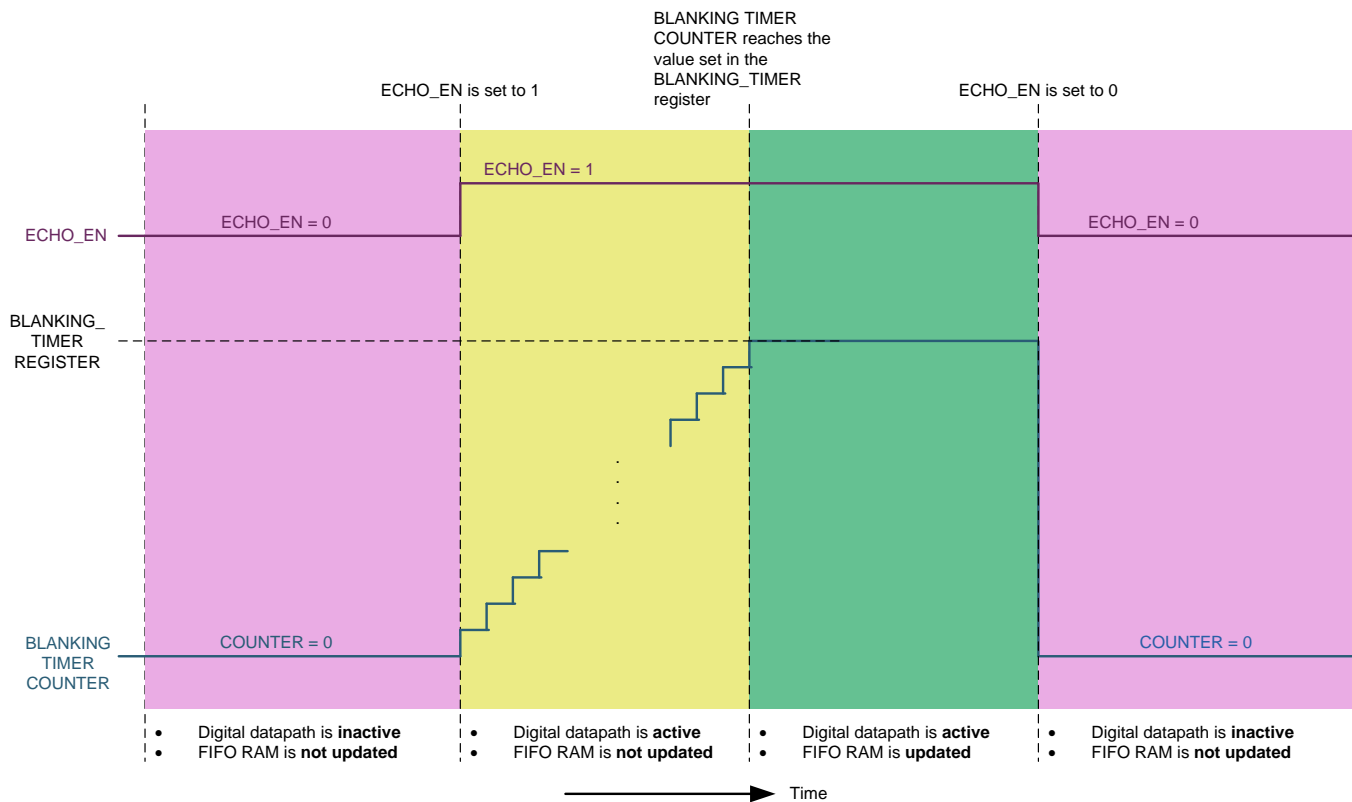

Figure 19. States of Digital Datapath

7.3.8.8 Digital Datapath Output Mode

The digital datapath output is available in the analog-voltage mode on the DACO pin with the following constraints:

- The DAC is an 8-bit DAC. The DAC output works only in the 8-bit MSB, 8-bit LSB, or 8-bit middle-significant-bits modes of the digital datapath output.
- The DAC output voltage range is 0.133 V to 1.125 V with 8-bit resolution. The digital datapath output is directly scaled to the analog output voltage in this range.
- The DAC output voltage resolution is 1 / 255 V.
- An external amplifier or buffer may be needed before the output of the DAC can be used to drive a load or viewed on a scope.
- The ANALOG_MUX ESFR is used to control the availability of the DAC output on DACO pin. The reset state of the DACO is NONE which means that no internal signal is available until after POR.
- When the digital datapath output on DACO is enabled, the temperature sensor register (TEMP_SENS) is not

updated.

To enable the temperature sensor or the digital datapath output, the TS_DAC_EN bit in TEMP_DAC_CTRL ESFR must be set to 1. The TS_DAC_mode bit determines whether the DAC is used for the temperature sensor or the digital datapath output.

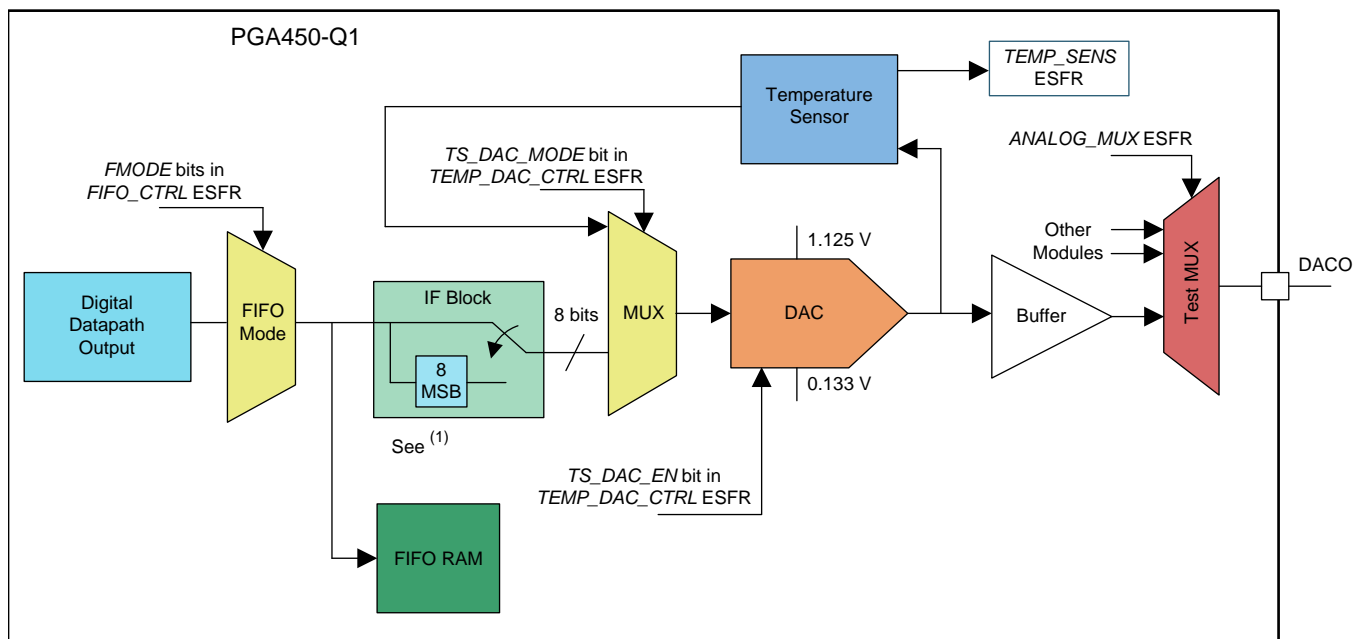

(1) IF the FIFO_CTRL bit is in 8-bit mode, output datapath, otherwise output 8-bit MSB.

Figure 20. Availability of Digital Datapath Output as an Analog Output on DACO

7.3.9 Transducer Saturation Time

The transducer saturation block is used to measure the *saturation time* of the transducer. The measurement is based on the voltage at the LIM pin of the PGA450-Q1.

The transducer saturation time is defined as the time from when the SAT_EN bit in the enable control (EN_CTRL) register is set to 1 to the time when the voltage at LIM falls below the programmable threshold and stays below that threshold for the programmable deglitch time.

Figure 21 shows the block diagram of the transducer saturation-time measurement block. The saturation-time measurement is accomplished with the following registers.

- EN_CTRL register — set the SAT_EN bit.
- CONTROL_1 register — set the saturation threshold with the SAT_SEL1 and SAT_SEL0 bits
- SAT_DEGLITCH register (the saturation deglitch time register) — 8 bits at 2 μ s resolution
- SAT_TIME register (the saturation time capture register) — 8 bits at 16 μ s
- STATUS2 register — set the SAT_DONE bit

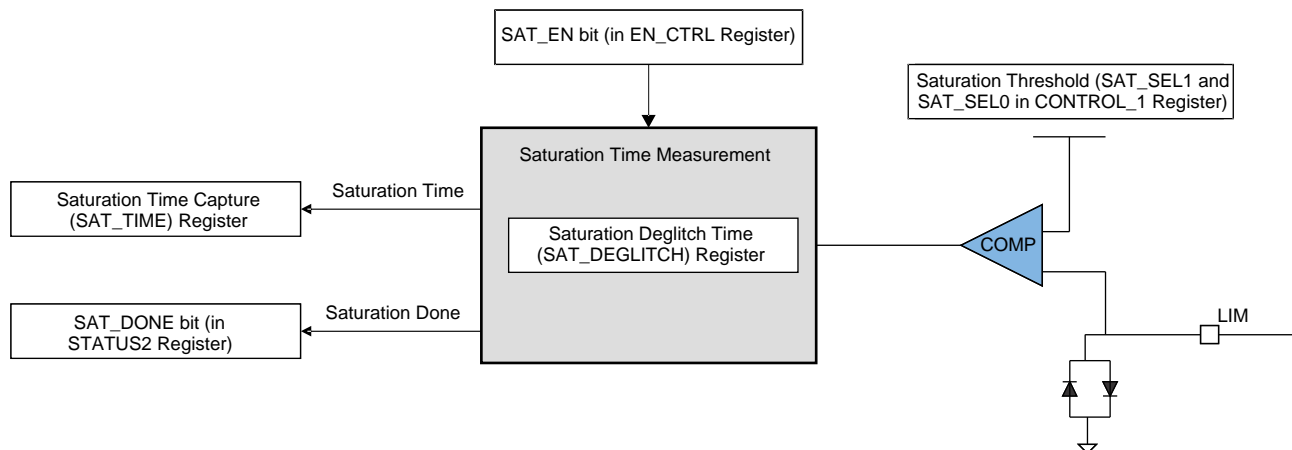

Figure 21. Transducer Saturation-Time Measurement Block

Figure 22 shows the timing diagram of the saturation-time measurement. The figure shows that an internal saturation timer starts when the SAT_EN bit in the EN_CTRL register is set to 1. The saturation-time measurement block then monitors **only** the positive voltage on the LIM pin. When this voltage goes below the programmed saturation threshold, the saturation-time deglitch timer is started.

NOTES:

- When the deglitch timer reaches the programmed deglitch time in the SAT_DEGLITCH register, the value in the internal saturation timer is captured into the SAT_TIME register and the SAT_DONE bit is set to 1.
- If the voltage at the LIM pin does not go below the programmed threshold after the SAT_EN bit is set to 1, then the SAT_DONE bit remains at 0. In this case, the maximum value of the SAT_TIME register is 0xFF.
- Setting the SAT_EN bit to 0 resets the SAT_TIME register to 0 and sets the SAT_DONE bit to 0.

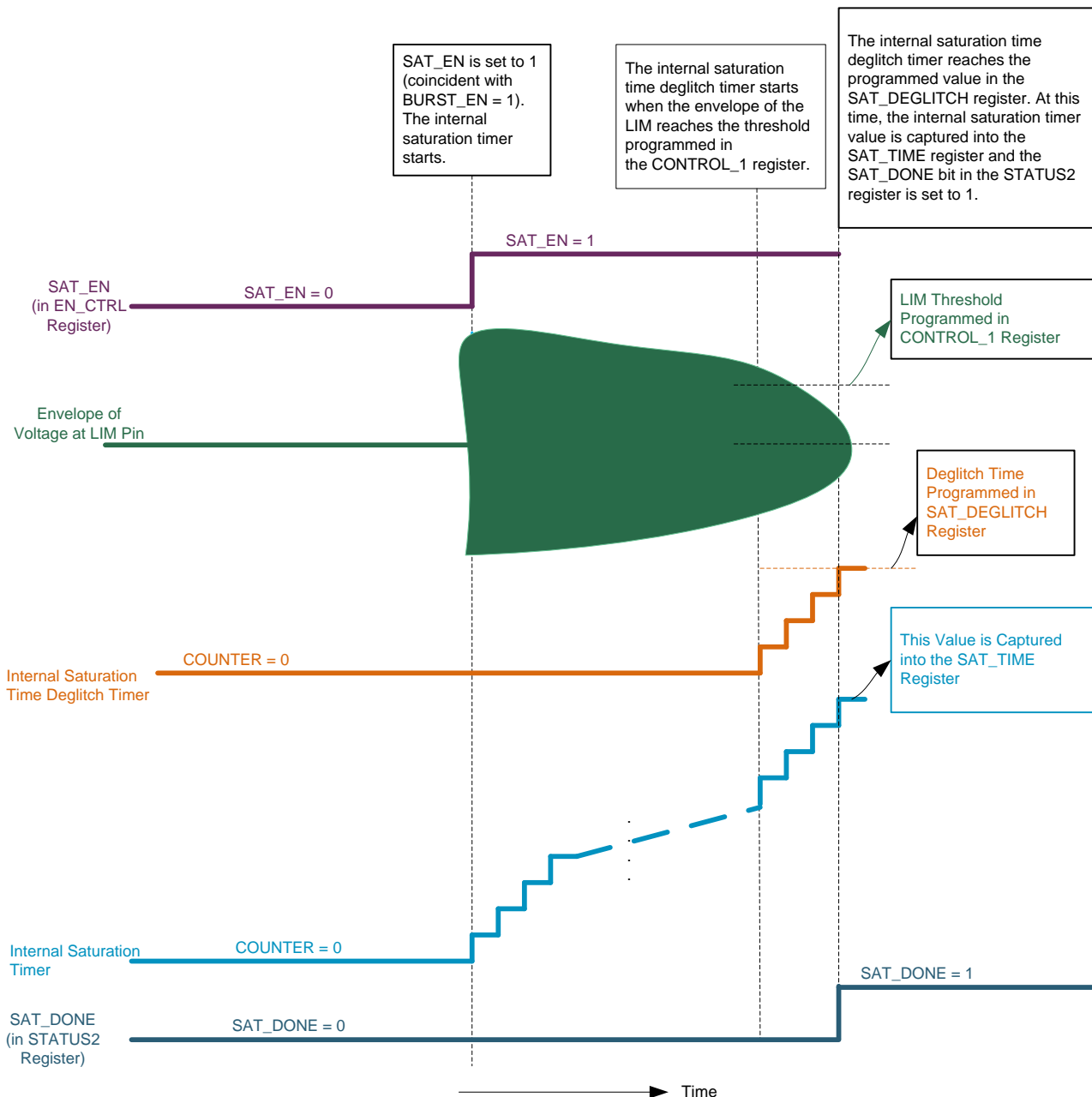

Figure 22. Timing Diagram Showing the Measurement of Transducer Saturation Time

7.3.10 Temperature Sensor

The PGA450-Q1 has an on-chip temperature sensor that provides a signed 8-bit 2s-complement output (MSB is the sign bit) with code 0 corresponding to 30°C. The temperature sensor has a typical gain of 1.75°C / code. The temperature sensor is disabled by default. The TS_DAC_EN bit in the TEMP_DAC_CTRL register must be set to enable the temperature sensor. The conversion time is typically 1.4 ms.

Equation 4 is the nominal equation for the temperature in °C.

$$\text{Temperature} = 1.75 \times \text{ADC_CODE} + 30 \tag{4}$$

7.3.11 Free-Running Timer

The PGA450-Q1 includes a 16-bit free-running timer that operates at a resolution of 1 μ s. This timer can be used to synchronize echo transit times between two different PGA450-Q1 devices by the master ECU in triangulation applications.

This timer starts from a reset value of 0 at POR and counts up. When the timer values reaches 0xFFFF, the timer rolls over to 0x0000.

The value of the free-running timer is not visible to the 8051W. However, the instantaneous value of the free-running timer can be captured into the free-running timer (FRT) capture ESFR by setting the CAP_FR_TIMER bit in the ENABLE CONTROL register to 1.

The FRT ESFR is a shadow of the free-running timer. The shadow register is not updated continuously. To copy the current value of the free-running timer into the ESFR, do the following:

- Write a 1 to the CAP_FR_TIMER bit in the EN_CTRL register.
- Read the FRT register.

See the [Register Maps](#) section for descriptions of the registers.

NOTE

The reason for implementing the FRT register as a shadow register is to allow the reading of the MSB and LSB coherently. The transfer from the free-running timer value to the FRT register is a 16-bit transfer and it is coherent. Because the 8051 can read only 1 byte at a time, coherency is maintained between two MSB and LSB reads of the FRT register because the FRT register value does not change between the reads of the MSB and LSB.

7.3.12 GPIOs

The GPIOx pins on the PGA450-Q1 can be used as either general-purpose inputs and outputs (I/Os) or can be used as I/Os for specific functionality.

In the general-purpose I/Os mode, the GPIOx pins are connected to specific 8051W port pins. User software can be used to control the state of the device pins by controlling the appropriate I/O port SFRs in the 8051W. [Table 10](#) lists the mapping of the PGA450-Q1 GPIOx pins to specific 8051W ports.

Table 10. GPIOx Pin Map

PGA450-Q1 Pin	8051W PORT
GPIO1	3.4
GPIO2	3.5

7.3.13 8051W UART

The TxD and RxD pins on the PGA450-Q1 are connected to the 8051W UART. These two pins can be used either for software debugging or for implementing application-specific protocols.

Table 11. TxD and RxD Pin Functionality

PGA450-Q1 Pin	8051W PORT
TxD	3.1
RxD	3.0

7.3.14 8051 WARP Core

The 8051 WARP core is an exceptionally high-performance version of this popular 8-bit microcontroller, requiring just 2 clocks per machine cycle rather than the 12 clocks per cycle of the industry-standard device, while keeping functional compatibility with the standard part. The 8051W core in the PGA450-Q1 includes two 16-bit timers and a serial interface.

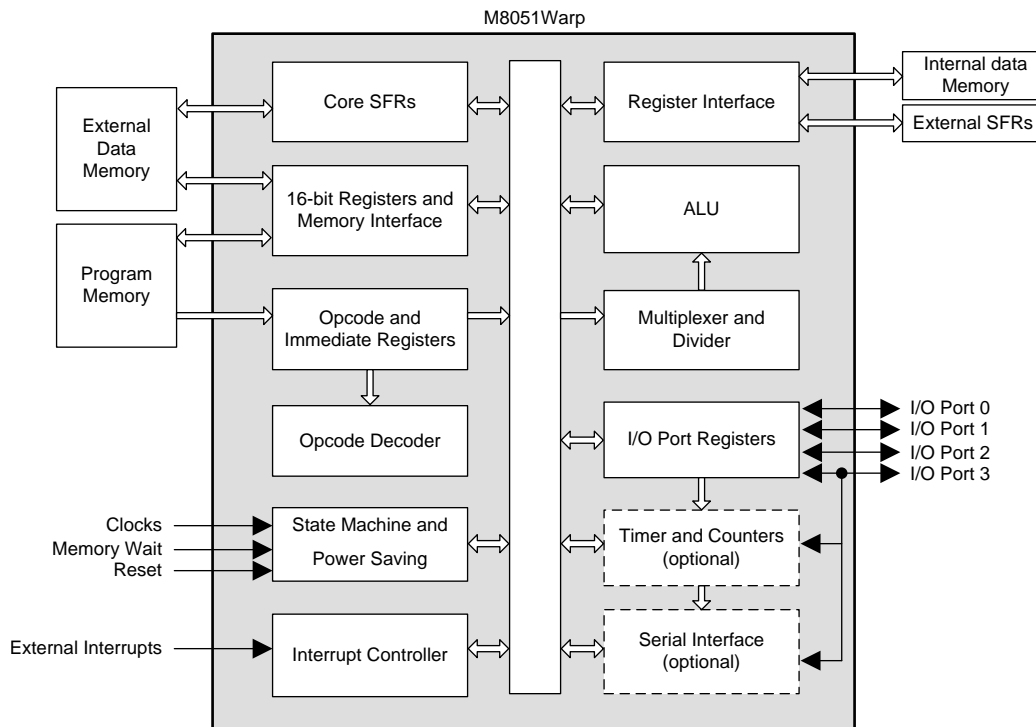

Figure 23. 8051W Core

7.3.15 Memory

Table 12 lists the PGA450-Q1 memory types.

Table 12. Memory

MEMORY	SIZE	DESCRIPTION
FIFO_RAM ⁽¹⁾	768 bytes	Digital datapath output
Scratchpad RAM	256 bytes	Used for software variables
OTP	8K bytes	Program code
EEPROM	32 bytes	Configuration data
DEVELOPMENT RAM	8K bytes	Program code during development

(1) FIFO is needed to allow a second scan of the digital datapath output. The minimum needed for the second scan is 512 bytes. Dual-port capability is needed so that digital datapath can fill and the microprocessor can read simultaneously. If a true dual port cannot be implemented, then an interrupt once every X number of bytes are available works. X can be 32 to 128 bytes. 768 bytes are needed to address the microprocessor throughput issue. If throughput of the microprocessor can be improved, 256 bytes could be sufficient.

7.3.15.1 FIFO Memory for Digital Datapath Output

The FIFO memory is volatile RAM memory. The output of the digital datapath is stored in the FIFO memory.

The FIFO memory is memory-mapped to the 8051W external memory address space. The contents of the FIFO memory are accessible to the 8051W core.

The FIFO memory is a dual-port RAM; that is, that the 8051W can read the FIFO contents while the digital datapath is filling the memory.

The FIFO memory also has a FIFO pointer, which is stored in the FIFO_POINTER register. The FIFO pointer behavior is as follows:

- The FIFO pointer has the address of the last FIFO byte that was filled by the digital datapath.
- If the digital datapath has been configured to output data in 12-bit format, the FIFO pointer value increases by 2.
- If the digital datapath outputs data in 8-bit format, the FIFO pointer value increases by 1.

The FIFO pointer is reset to 0 at power up. Similarly, when the ECHO_EN bit in the EN_CTRL register is set to 1, the FIFO pointer value is reset to 0. However, the FIFO memory contents are not cleared to 0.

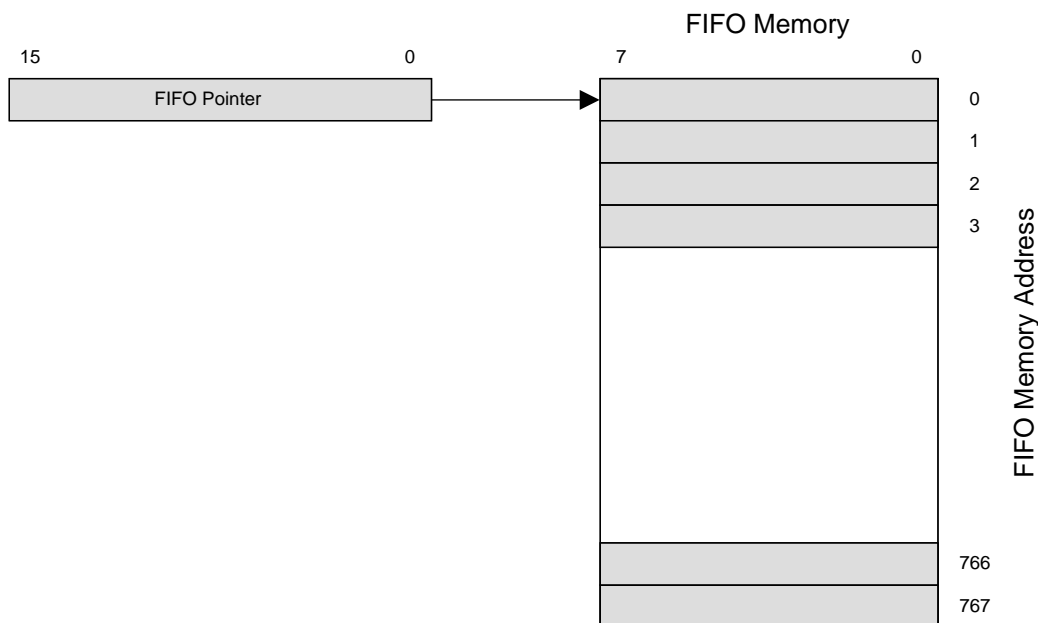

Figure 24. FIFO Memory Organization

7.3.15.2 OTP Memory for Program

The programming voltage for the OTP memory must be provided externally, because the device does not have a voltage regulator to generate the OTP programming voltage. This voltage must be provided on the VPROG_OTP pin.

7.3.15.2.1 OTP Security

The PGA450-Q1 provides the ability to LOCK the OTP. The OTP memory cannot be read or programmed through the SPI. This feature is called OTP security.

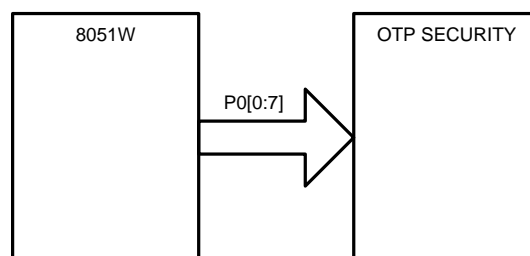

Figure 25. Connection Between the 8051W Core and OTP Security Block

The following is the procedure to LOCK and UNLOCK the OTP

- To LOCK the OTP memory, 8051W P0 should be set to 0xAA in software.
- To UNLOCK the OTP memory, 8051W P0 should be set to 0x00 in software.

NOTE

- Writing to P0 immediately after the 8051W reset is deasserted (immediately after the 8051W starts running software) is recommended.
 - When the OTP memory is in LOCK state, the 8051W processor has access to OTP memory; that is, program execution can continue.
 - If the 8051W processor is put in the reset state after a LOCK instruction in software has been executed, the OTP memory cannot be accessed through the SPI.
-

7.3.15.2.2 OTP Programming

Both the 8051W microprocessor and the SPI can access the 8K OTP memory. The 8051W has read access only. The SPI has read access and program access.

Prior to starting the OTP programming process, raising the VPROG_OTP pin on the PGA450-Q1 to 8 V is required. When the voltage on this device pin reaches this level, the OTP programming mode is enabled.

NOTE

The OTP programming voltage should not be connected to the pin for an extended period of time.

CAUTION

Do not power up OR power down the PGA450-Q1 with the VPROG_OTP pin set to 8 V, this may cause unrecoverable corruption to the OTP data.

Programming of the OTP must be done one address at a time. Each address can only be programmed once. After an address is programmed, it cannot be programmed again. Programming a section of the OTP address space and then programming an additional section of OTP address space at a later time is possible.

To program a byte of OTP, four bytes must be sent through SPI. The first byte is 0x07 indicating an OTP write operation. The next 2 bytes contain the address of the target OTP location and the last byte contains the data.

There should be at least 100 μ s between two successive OTP write instructions. This time is needed to ensure the proper programming of the OTP cell. Violation of this might cause data retention issues for the OTP memory during the lifetime of the device. With a 4-MHz SCK frequency, it takes approximately 1 s to program the entire 8K address space of the OTP.

The following is the OTP memory programming procedure:

1. After power up, set the VPROG_OTP pin to 8 V.
2. Send an OTP write command through the SPI.
3. **The \overline{CS} pin is set to HIGH at least 100 μ s for the OTP programming process to complete.** Do not perform any SPI write operations to the OTP during the OTP programming process.
4. Repeat Steps 2 and 3 until all desired OTP addresses have been programmed.
5. Before powering down the PGA450-Q1 device, disconnect the 8-V supply to VPROG_OTP pin.

7.3.15.3 EEPROM Memory for Data

Figure 26 shows the EEPROM structure in the PGA450-Q1 device. The EEPROM structure in PGA450-Q1 includes volatile cache. The cache has one-to-one mapping with the nonvolatile EEPROM memory cells. The EEPROM cache is mapped into the external memory space of the 8051W memory map.

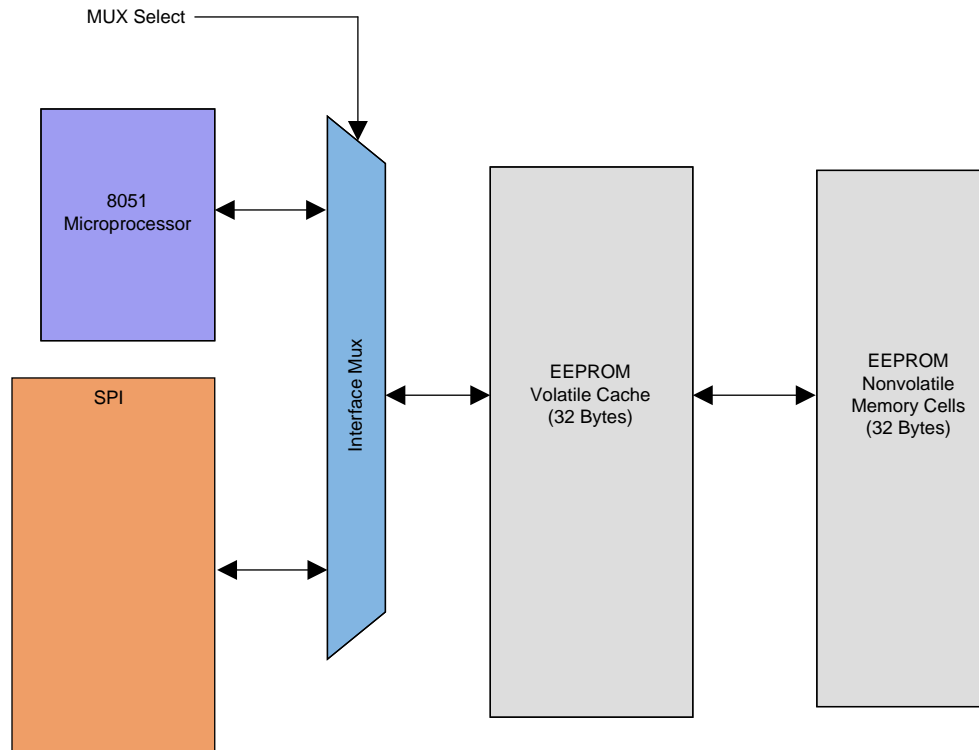

Figure 26. Structure of EEPROM Interface

7.3.15.3.1 EEPROM Memory Organization

7.3.15.3.1.1 EEPROM Cache

The EEPROM cache serves as temporary storage of data being transferred to or from EEPROM. Data transferred to the EEPROM cache from either SPI or from the M8051 is byte-addressable, and one byte at a time can be written to or read from the EEPROM cache. Selection of the EEPROM cache interface is determined by the internally generated MUX-select bit. The MUX-select bit is by default set to 8051W access. The EEPROM cache is accessible to the SPI when the 8051W is put in reset in the test mode.

When programming to EEPROM through the SPI, the EEPROM cache holds the programming data for the amount of time necessary to complete the EEPROM programming process.

7.3.15.3.1.2 EEPROM Memory Cells

The EEPROM memory cells are nonvolatile. The contents of the cache are programmed into the EEPROM when the 8051W requests the programming. The cache is loaded with the contents of the EEPROM memory cells at power up.

7.3.15.3.2 Programming EEPROM Through the 8051W and SPI

The following is the EEPROM memory programming procedure:

1. Write data to EEPROM cache
 - Use the 8051W MOVX assembly instruction to place data in external memory addresses 0x0400 through 0x041F.
2. Write a 1 to the WRITE bit in the EE_CTRL register.
3. Continuously poll the EE_STATUS bit in EE_CTRL register for the programming status. The EEPROM programming requires 70 ms to complete.

7.3.15.3.3 Reloading From EEPROM Cells Through the 8051W and SPI

The following is the reloading procedure:

1. Write a 1 to the RELOAD bit in the EE_CTRL register which causes the EEPROM cells to be loaded into cache. The reload operation requires 125 μ s to complete.
2. Use the 8051W MOVX assembly instruction to transfer data from the cache to internal RAM.

7.3.16 LIN 2.1 Slave and Buffered SCI

The PGA450-Q1 implements the LIN 2.1 compliant physical layer. This physical layer can be used to communicate data between the PGA450-Q1 and the master ECU.

The PGA450-Q1 can be configured to operate in the LIN 2.1 slave-protocol mode or SCI buffered mode. If the device is configured in LIN 2.1 slave-protocol mode, then the protocol layer described in Section 2.1 of the LIN 2.1 specification must be used to communicate with the PGA450-Q1. The device can only be configured as a slave; that is, the PGA450-Q1 cannot be used as a master.

The LIN 2.1 slave protocol implemented in PGA450-Q1 has the following exceptions:

- No wake-up (Section 2.6.2 of LIN 2.1). The device cannot be put to sleep and be woken through the LIN.
- No transport layer in digital logic (Section 3 of LIN 2.1)
- No node configuration and identification services in digital (Section 4 of LIN 2.1)
- No diagnostic layer in digital logic (Section 5 of LIN 2.1)
- Communication baud rate is fixed at 19.2 kbps. That is, the device baud rate is not configurable.

The PGA450-Q1 can also be configured to operate in SCI buffered mode. In this mode, no specific protocol is needed to communicate with the PGA450-Q1. The user has the choice to implement the protocol in software. The device provides the ability either to transmit or to receive 8 bytes of data without any intervention from 8051W software.

The user selects either LIN 2.1 slave mode or SCI buffered mode by setting the LIN_SCI bit in the LIN_SCI_SEL register. If the LIN_SCI bit is changed from LIN mode to SCI mode or vice versa, the communication protocol is reset.

7.3.16.1 Physical Layer

The physical layer inside the PGA450-Q1 is compliant with the LIN 2.1 specification. Figure 27 shows the line driver and receiver schematic illustrated in the LIN 2.1 specification. The inner dashed box in Figure 27 identifies the section that has been implemented in the PGA450-Q1.

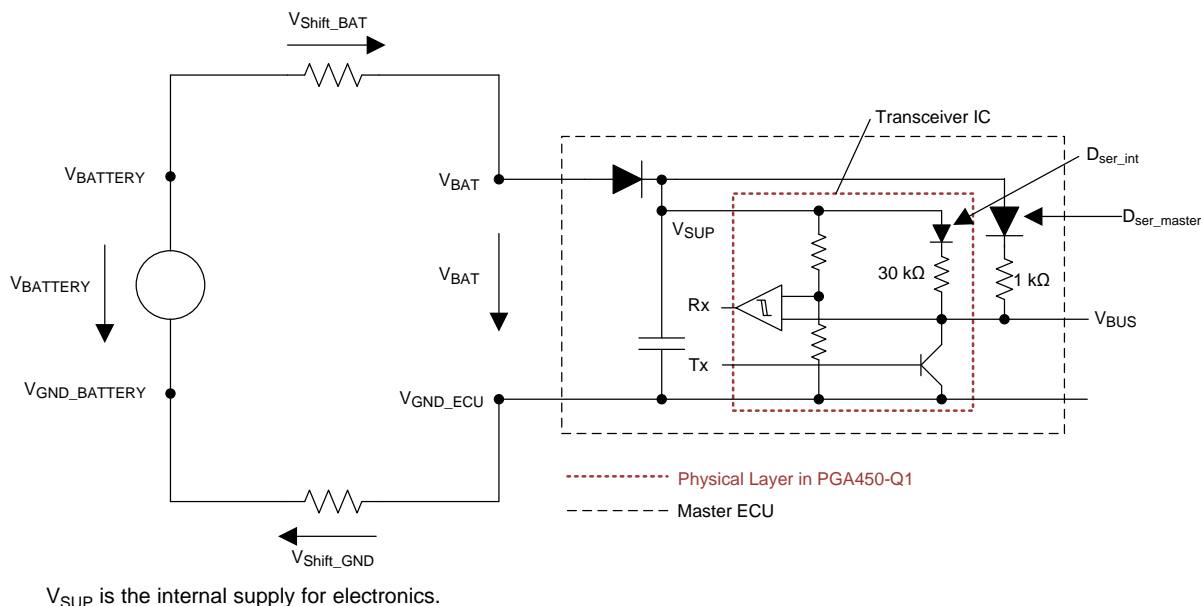

Figure 27. LIN Physical Layer in LIN 2.1 Specification

Figure 28 shows the schematic of the LIN 2.1 physical layer in PGA450-Q1. This figure infers that the PGA450-Q1 implements the LIN 2.1 slave physical layer.

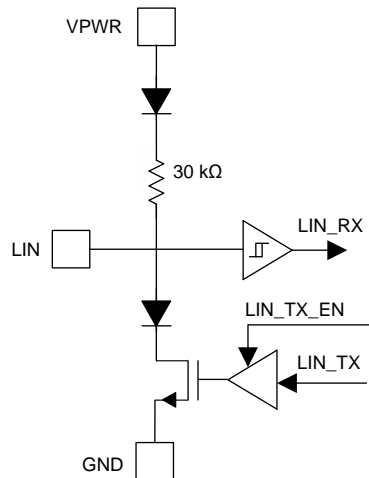

Figure 28. LIN Physical Layer in the PGA450-Q1

7.3.16.2 LIN Slave Mode

This section describes the LIN slave protocol mode of operation of the PGA450-Q1.

7.3.16.2.1 LIN Frame

This peripheral handles the LIN 2.1 frames shown in Figure 29. The LIN 2.1 frame has a break field, sync field, PID field, data fields, and checksum field.

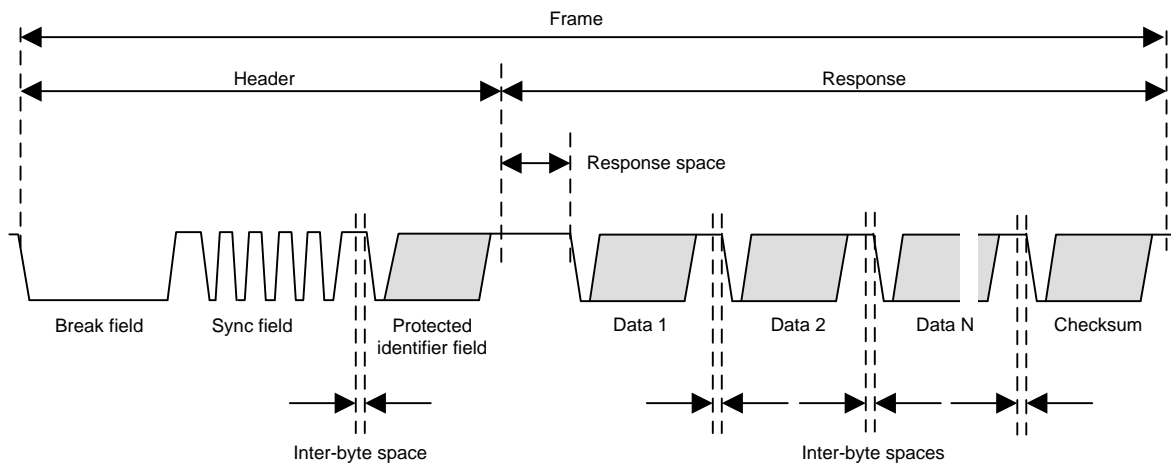

Figure 29. LIN Frame From the LIN 2.1 Specification

Figure 30 shows the LIN byte field. This figure shows that the LIN byte field has 1 start bit and 1 stop bit. The least-significant bit (LSB) is transmitted first.



Figure 30. LIN Byte Field From the LIN 2.1 Specification

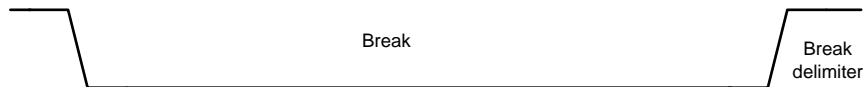

Figure 31. LIN Break Field From the LIN 2.1 Specification

A break field is always generated by the master task (in the master node) and it shall be at least 13 nominal bit times of dominant value, followed by a break delimiter.



Figure 32. LIN Sync Field From the LIN 2.1 Specification

Sync is a byte field with the data value 0x55.

7.3.16.2.2 LIN Registers

Figure 33 shows all the registers associated with the LIN peripheral. The LIN PID, RX DATA0–7 and TX DATA0–7 have unique registers associated with them.

Address	Register Name	Category
0xBF	LIN_SCI_SEL Register	LIN Control and Status Registers
0xDC	LIN_CFG Register	
0xDD	LIN_CTRL Register	
0xDE	LIN_STATUS Register	
0xDB	DATA_CNT Register	
0xD2	LIN_PID Register	LIN Data Registers
0xC9	LIN/SCI RX_DATA0 Register	
0xCA	LIN/SCI RX_DATA1 Register	
0xCB	LIN/SCI RX_DATA2 Register	
0xCC	LIN/SCI RX_DATA3 Register	
0xCD	LIN/SCI RX_DATA0 Register	
0xCE	LIN/SCI RX_DATA1 Register	
0xCF	LIN/SCI RX_DATA2 Register	
0xD1	LIN/SCI RX_DATA3 Register	
0xD3	LIN/SCI TX_DATA0 Register	
0xD4	LIN/SCI TX_DATA1 Register	
0xD5	LIN/SCI TX_DATA2 Register	
0xD6	LIN/SCI TX_DATA3 Register	
0xD7	LIN/SCI TX_DATA0 Register	
0xD8	LIN/SCI TX_DATA1 Register	
0xD9	LIN/SCI TX_DATA2 Register	
0xDA	LIN/SCI TX_DATA3 Register	

Figure 33. LIN Registers

NOTE

The PGA450-Q1 LIN slave protocol does not decode the LIN PID registers. The decoding logic for the PID registers must be implemented in 8051W software.

7.3.16.2.3 LIN Interrupts

Figure 34 shows the four interrupts that the LIN slave protocol generates. These interrupts are:

SYNC interrupt: This interrupt is generated by the LIN slave protocol when the SYNC field is received. Note that the SYNC field interrupt is generated regardless of whether the subsequent LIN frame fields are received. Thus, the customers can use the BREAK+SYNC fields to synchronize the internal clock and use other protocols for communication.

PID interrupt: This interrupt is generated by the LIN slave protocol when the PID is received and the PID does not have a parity error.

Rx interrupt: This interrupt is generated by the LIN slave protocol when the PGA450-Q1 receives the LIN data. The interrupt is generated only when the checksum is received and the checksum has no errors. The device performs the enhanced checksum calculation. According to the LIN 2.1 specification, the enhanced checksum is the checksum calculation over the data bytes and the protected identifier byte.

Tx interrupt: This interrupt is generated by the LIN slave protocol when the PGA450-Q1 transmits data. The interrupt is generated at the end of the checksum transmission.

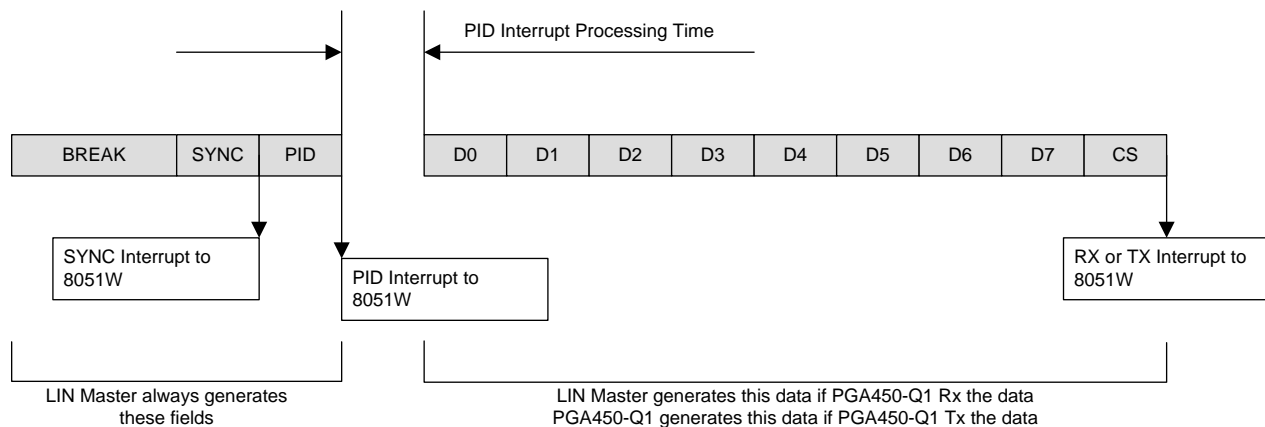

Figure 34. LIN Interrupts

The PID interrupt processing shown in Figure 34 is for a transmit message.

7.3.16.2.4 LIN Slave Configuration

The LIN slave in the PGA450-Q1 is configurable. This section describes the available configurations. These configurations are not applicable if the PGA450-Q1 is set up to operate in SCI buffered mode.

The LIN configuration register, LIN_CFG, is used to configure the LIN slave in the PGA450-Q1. The following sections describe the possible configurations.

7.3.16.2.4.1 LIN Frame-Control Configuration

The PGA450-Q1 has three bits that control the behavior of the PGA450-Q1 when a LIN frame is received.

IGNORE_DIAG: This bit controls the mode of operation of the LIN slave controller when the PID is received. If this bit is set to 0, then the LIN slave controller waits for data bytes after the PID field in the LIN frame is received.

If this bit is set to 1, then the LIN slave controller finishes the current frame after the PID is received and waits for the next LIN frame.

HOLD: This bit determines whether the LIN frame received by PGA450-Q1 is processed or ignored.

If this bit is set to 1 (which is the power ON reset state), then the received LIN frame is ignored.

If this bit is set to 0, then the received LIN frame is not ignored.

CS_METHOD: This bit controls whether the checksum is classic checksum or enhanced checksum.

If this bit is set to 0 (which is power ON reset state), the LIN protocol calculates and validates the checksum using the classic checksum method.

If this bit is set to 1, the LIN protocol calculates and validates the checksum using the enhanced checksum method.

7.3.16.2.4.2 LIN Timing-Control Configuration

The PGA450-Q1 has two bits that control the various timing parameters of the LIN frame.

INTERBYTE_SPACE: This bit controls the duration of the time between the data fields when PGA450-Q1 is transmitting data.

If this bit is set to 0, then the interbyte space is equal to 1 bit.

If this bit is set to 1, then the interbyte space is equal to 2 bits.

BIT_TOL: This bit controls the tolerance of bit time that is used in the LIN frame timing diagnostics.

If this bit is set to 0, the bit time tolerance is 15% of the bit time determined during the LIN SYNC field.

If this bit is set to 1, the bit time tolerance is 30% of the bit time determined during the LIN SYNC field.

7.3.16.2.5 LIN Slave-Protocol State Machine

[Figure 35](#) shows the LIN slave-protocol state machine implemented inside PGA450-Q1. The figure shows that the protocol enters the Wait-for-Break-Field state on power up. When the master sends the break field, the state machine transitions into the Wait-for-Sync-Field state only if the HOLD bit in the LIN_CFG register is set to 0. Otherwise, the LIN protocol return to the Wait-for-Break-Field state.

After the sync field is received, the state machine generates the SYNC field interrupt and transitions into the Wait-for-PID-Field state. After the PID field is received, the PID parity is checked. If the parity has an error, then the state machine transitions back to the Wait-for-Break-Field state. If there is no parity error, then the state machine generates the PID interrupt to the 8051W.

The user must write software to service the PID interrupt. In the PID interrupt service routine, the user determines whether the received PID corresponds to Rx message or Tx message.

In the case of an Rx message, the state machine waits for all the data bytes to be received. The number of data bytes received is determined by the value in the DATA_CNT register. When all the data bytes are received, then the state machine calculates the checksum. If the calculated checksum matches the received checksum, then the state machine generates an Rx interrupt to the 8051W. Otherwise, the state machine transitions back to Wait-for-Break-Field state.

In the case of a Tx Message, the state machine calculates the checksum based on the data after the 8051W loads the transmit buffers and the DATA_CNT register. At the end of frame transmission (that is, when the checksum is transmitted), the state machine generates a Tx interrupt to the 8051W.

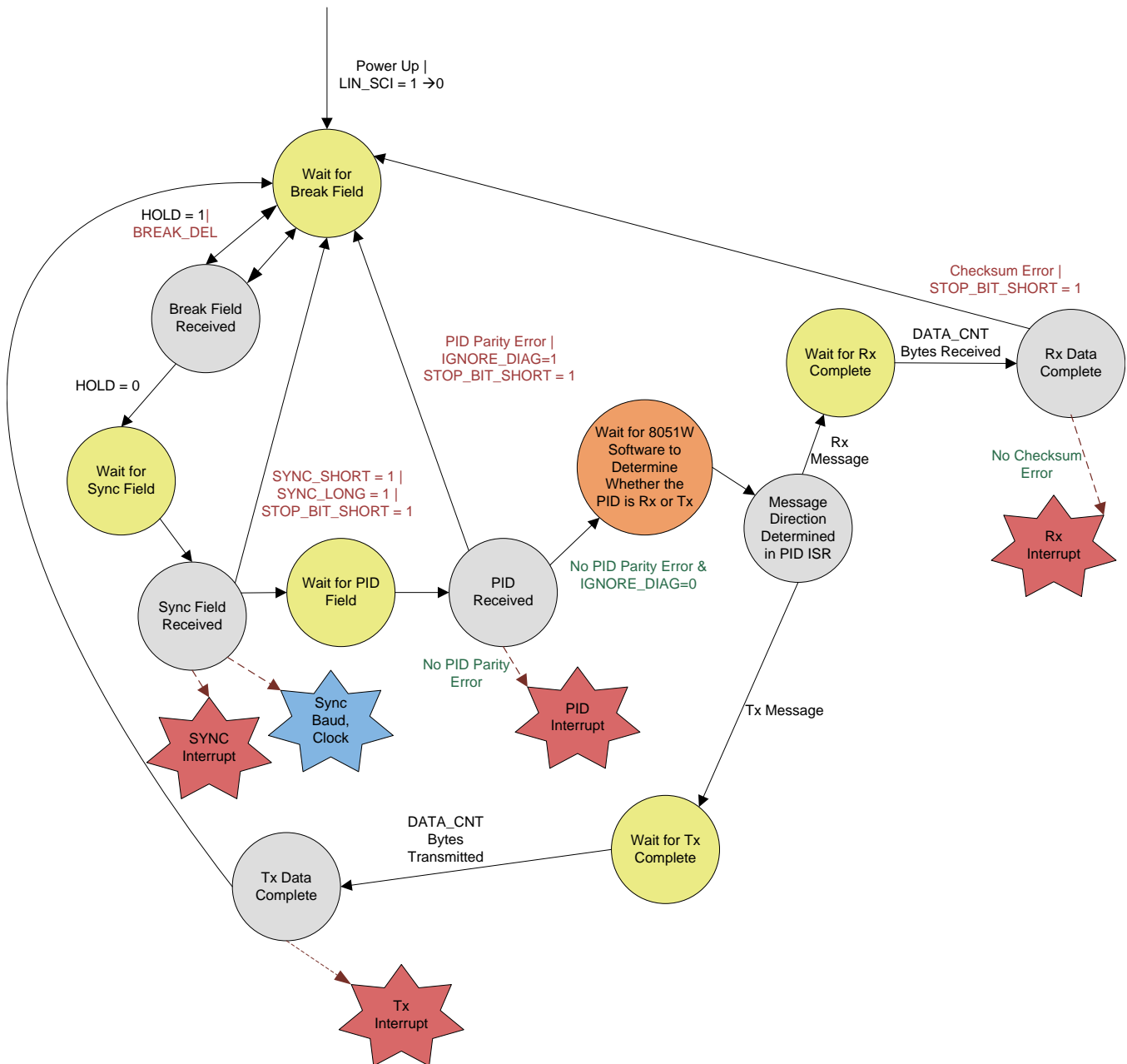

Note: When the LIN_SCI bit is changed from LIN mode to SCI mode while the LIN mode is in any of the states, the LIN state machine goes to the Wait-for-Break-Field state.

Figure 35. LIN Controller State Machine

7.3.16.2.6 LIN Slave Protocol Rx

If the PID field corresponds to an Rx message, the following are the steps to receive a LIN message.

In the PID interrupt service routine, do the following:

- Load the DATA_CNT ESFR with the expected number of Rx data bytes.
- Set the RX_TX bit in the LIN_CTRL ESFR to 0 to receive a message.

In the Rx interrupt service routine, do the following:

- Transfer data from the RX_DATA buffers to RAM.

See the [ESFR Registers](#) section for details on the ESFRs.

7.3.16.2.7 LIN Slave Protocol Tx

If the PID field corresponds to a Tx message, the following are the steps to transmit a LIN message.

In the PID interrupt service routine, do the following:

- Load DATA_CNT ESFR with the number of data bytes to be transmitted.
- Load TX_DATA buffers with the data that is to be transmitted.
- Set the RX_TX bit in LIN_CTRL ESFR to 1 to transmit a message.

When the Tx interrupt service routine is called, the message transmission is complete. Nothing is required in the Tx interrupt service routine.

See the [ESFR Registers](#) section for details on the ESFRs.

NOTE

The LIN PID will be received and stored in the LIN_PID ESFR. This register will be cleared when the LIN message transmission or reception is complete. Therefore, to retain the value of the LIN_PID, the user has to copy the value of the ESFR to a RAM variable.

7.3.16.2.8 LIN Slave Status

The PGA450-Q1 has a LIN status (LIN_STATUS) register that has the error status of the received LIN frame.

This LIN_STATUS register can be cleared at any time by setting the CLR_ERR bit in the LIN_CFG register to 1.

7.3.16.2.8.1 LIN Slave Framing Error Status

The LIN_STATUS register in the PGA450-Q1 has the following bits that reflect any framing errors in the received LIN message:

CHECKSUM: This bit is set to 1 if the received checksum does not match the calculated checksum.

PARITY: This bit is set to 1 if the received PID has a parity error.

STOP_BIT_VAL: This bit is set to 1 if the LIN bus does not go high for a stop bit right after the 8th data bit is received or transmitted. This check is done at the end of each Tx and Rx data byte.

7.3.16.2.2 LIN Slave Timing Error Status

The LIN_STATUS register in the PGA450-Q1 has bits that reflect any LIN timing errors in the received LIN message. The timing errors are based on [Figure 36](#).

[Table 13](#) lists the various timing errors in the received LIN message that are detected by the PGA450-Q1.

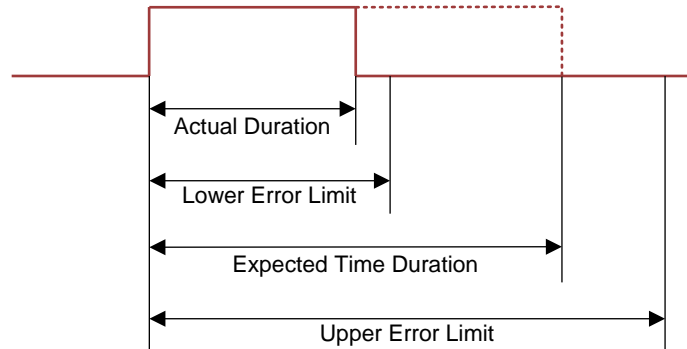

Figure 36. LIN Timing-Error Diagram

Table 13. LIN Timing Errors⁽¹⁾

ERROR BIT	DESCRIPTION	LOWER ERROR LIMIT	UPPER ERROR LIMIT
STOP_BIT_SHORT	STOP bit received in PID or data bytes is shorter than expected.	$52 \mu\text{s} \times (1 - \text{BIT_TOL})$	
SYNC_SHORT	SYNC field duration is shorter than expected.	485 μs	
SYNC_LONG	SYNC field duration is longer than expected.		555 μs
BREAK_DEL	BREAK FIELD delimiter is shorter than expected.	$52 \mu\text{s} \times (1 - \text{BIT_TOL})$	

(1) BIT_TOL: Bit tolerance programmed in the LIN_CFG register. The Bit Tolerance can be either 15% or 30%.

7.3.16.3 SCI Buffered Mode

In the SCI buffered mode, the PGA450-Q1 does not implement any special frame or protocol. Up to 8 bytes can be received and transmitted without any 8051W software intervention. That is, the software either reads (in the case of receive) from the Rx data buffer or writes (in the case of transmit) to the Tx data buffer the appropriate number of bytes.

The DATA_CNT ESFR determines the buffer length. When data is received by the device, SCI generates an Rx data interrupt only after the number of bytes specified in DATA_CNT register is received.

7.3.16.3.1 SCI Buffered-Mode State Machine

[Figure 37](#) shows the SCI buffered-mode state machine. If both the external device and the 8051W try to send data at the same time, a bus conflict occurs. This bus contention is not detected inside the PGA450-Q1.

If the external device sends more than 8 bytes (corresponding to the buffer length), then the data in the Rx data buffer is overwritten. Therefore, the 8051W has not had a chance to read the previous data in the buffer, so the data is lost.

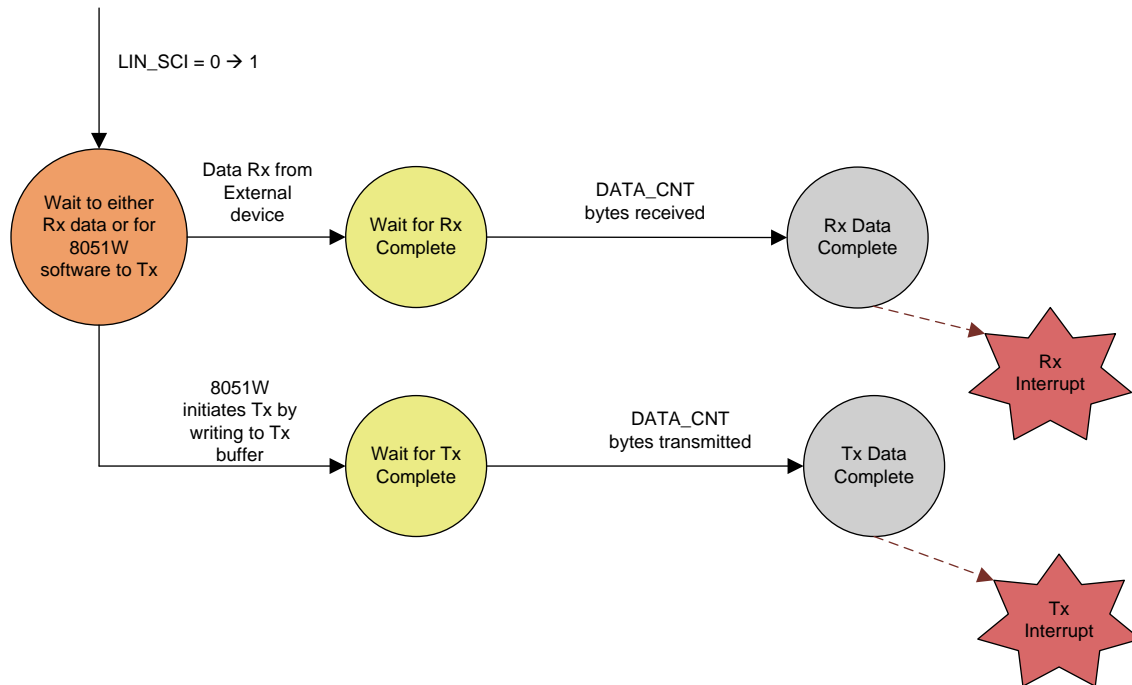

Figure 37. SCI Buffered-Mode State Machine

7.3.16.3.2 SCI Buffered-Mode Rx

The following are the steps to receive data on SCI:

- In software, do the following:
 - Load DATA_CNT ESFR with the expected number of Rx data bytes.
 - Set the RX_TX bit in LIN_CTRL ESFR to 0 to Rx a message.
- In the Rx interrupt service routine, do the following:
 - Transfer data from the RX_DATA buffers to RAM.

7.3.16.3.3 SCI Buffered-Mode Tx

The following are the steps to transmit data on SCI:

- In software, do the following:
 - Load DATA_CNT ESFR with the number of data bytes to be transmitted.
 - Load TX_DATA buffers with the data to be transmitted.
 - Set the SCI_TX_EN bit in DP_SCI_CTRL ESFR to 1 to Tx a message.
 - Set the RX_TX bit in LIN_CTRL ESFR to 1 to Tx a message.
- When the Tx interrupt service routine is called, the message transmission is complete. Nothing is required in the Tx interrupt service routine.

NOTE

DATA_CNT in SCI buffered mode: The minimum value for DATA_CNT in SCI buffered mode is 2; that is, when the device is configured to operate in SCI buffered mode, the device can receive or transmit a minimum of 2 bytes.

7.3.16.4 Connection of LIN Pin to 8051W

The LIN transceiver is connected to the 8051W I/O as shown in Figure 38.

The state of the LIN pin can be read by software by reading 8051W port 3, pin 2 and pin 3. Similarly, 8051W port 2, pin 3 can be used to drive the TX pin of the transceiver.

The state of the Rx pin from the transceiver should be inverted before the signal is routed to port 3, pin 3.

Logic 0 on P2.3 sets the LIN bus to the LOW state, whereas logic 1 on P2.3 sets the LIN bus to the HIGH state.

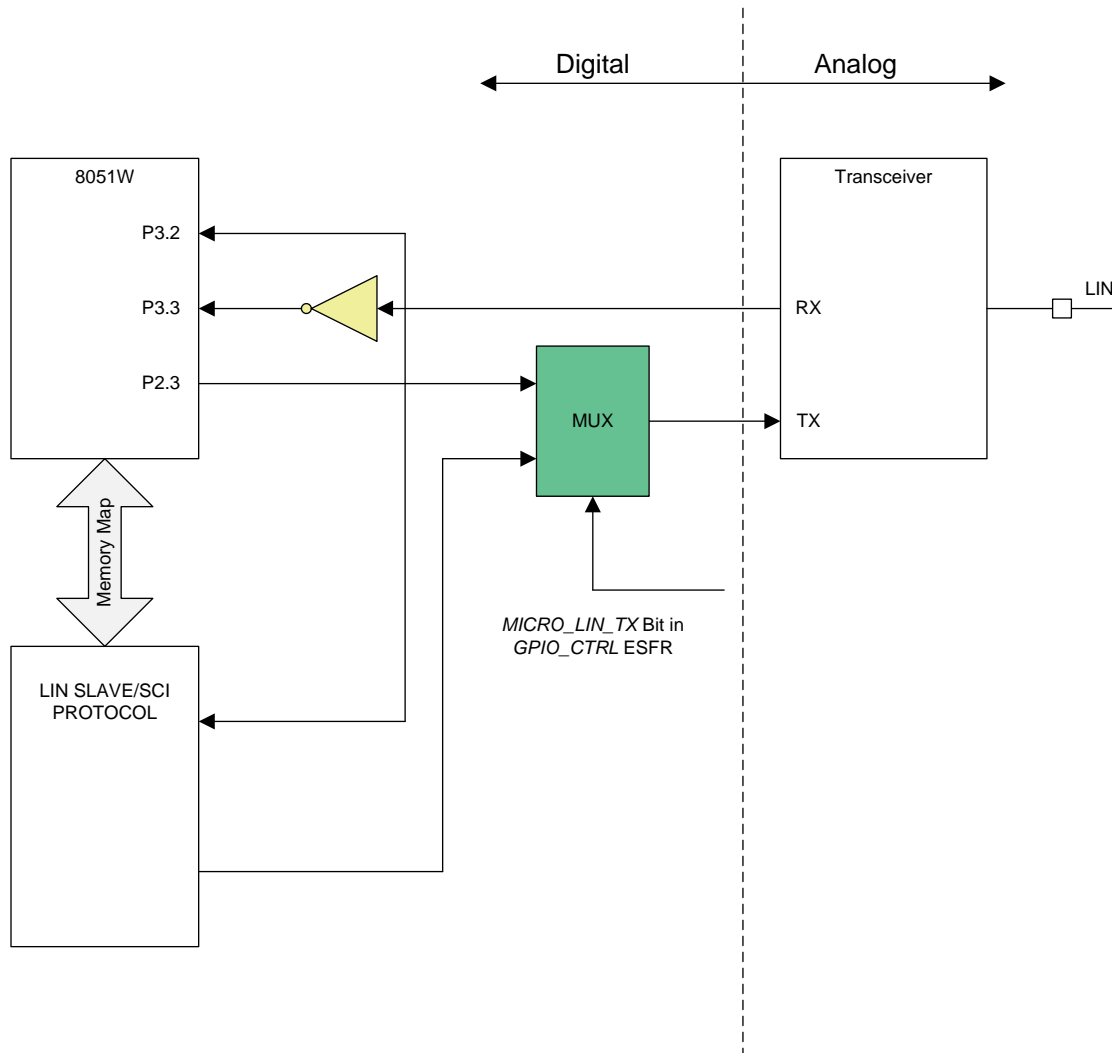

Figure 38. LIN Tx and Rx Pins Are Connected to 8051W Port Pins

The reason for routing the Rx pin to P3.2 and P3.3 is to allow the use of 8051W timer 1 to measure the durations of the LIN bus in the high or low state.

7.4 Device Functional Modes

7.4.1 Active Mode

The process of taking a measurement occurs when the device is in active mode. The low-side drivers, analog front-end, and digital data path are all active which allows for an ultrasonic signal to be transmitted and the reflected signal to be received and processed.

The maximum current (VREG not charging) in active mode is 15 mA.

Device Functional Modes (continued)

To enter active mode, set the ACTIVE_EN bit in the PWR_MODE register to 1.

7.4.2 Quiet Mode

In quiet mode, the device waits for a command which is given through a digital interface (such as LIN, SCI, or UART). The LNA, ADC, digital data path, and low-side drivers are all off. The VREG regulator can be either enabled or disabled. If the VREG regulator is charging, the maximum current is increased by 100 mA.

The maximum current (VREG not charging) in quiet mode is 7.5 mA.

To enter quiet mode, set the ACTIVE_EN bit in the PWR_MODE register to 0.

7.4.3 RESET

The PGA450-Q1 can also be put into a RESET state where the microcontroller is not active. During this state, SPI is the only digital interface that can be used. The low-side drivers can still be triggered to begin an ultrasonic burst and the analog front-end and digital data path can still store the returned echo signal in the FIFO RAM. However, any processing of the FIFO RAM by the internal microprocessor to determine the location of an object does not occur. The FIFO RAM data can be read over SPI, allowing an external microprocessor to process the data.

While the microcontroller is active, the MICRO RESET test register is the only register accessible through SPI. The device must be put into the RESET state before sending additional SPI commands.

The maximum current (VREG not charging) in the RESET state is 15 mA.

To put the microcontroller in reset, write a 1 to bit 0 of the MICRO RESET (address 0x2F) test register. Transmit the *TEST Write SPI* command in the following order: 0x16, 0x2F, 0x01.

To bring the microcontroller out of reset, write a 0 to bit 0 of the MICRO RESET (address 0x2F) test register. Transmit the *TEST Write SPI* command in the following order: 0x16, 0x2F, 0x00.

NOTE

The MICRO RESET (0x2F) register is an internal test register, which is why the field is not listed in the SFR or ESFR register map.

7.5 Programming

7.5.1 SPI Interface

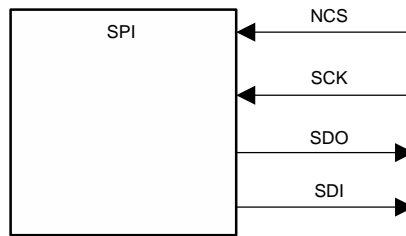

Figure 39. SPI Port in PGA450-Q1

The SPI block is used for communicating with the device during system development. The internal SPI acts as the slave in the communication of the device with an external SPI which is in master mode. To perform the communication, four external pins are necessary:

- SDI:** SPI slave-in master-out, serial-input pin
- SDO:** SPI slave-out master-in, serial-output pin (three-state output)
- SCLK:** SPI clock, which controls the communication
- $\overline{\text{CS}}$:** Chip select

The output data on the SDO pin (for example, CheckByte and read data) changes on the rising edge of SCLK. The input data on SDI is latched on the falling edge of SCLK. The data received during a write access is written to memory on the system clock after the $\overline{\text{CS}}$ pin has gone high.

In the absence of active transmission, the master SPI resets the internal SPI with $\overline{\text{CS}} = \text{high}$. MISO is in the high-impedance state during reset. Master and slave SPI transmit the MSB first.

NOTE

The PGA450-Q1 does not respond to SPI messages unless the 8051W microprocessor is in the reset state. The microprocessor can be put in the reset state by writing an appropriate value to the MICRO RESET test register. The MICRO RESET test register is the ONLY register that is accessible through the SPI when the 8051W processor is not in the reset state.

7.5.1.1 SPI Interface Protocol

The serial peripheral interface (SPI) uses a 1-byte command word and 2 or 3 additional bytes for the complete command.

Table 14 lists the SPI protocol.

Table 14. SPI Protocol Command Word

BIT	FUNCTION
15:13	Always 3'b000
12:10	Memory access control: 3'b001: OTP 3'b010: EXTERNAL RAM (FIFO, general-purpose) 3'b011: EEPROM 3'b100: IRAM 3'b101: TEST registers 3'b110: ESFR 3'b111: Development RAM
9	R/W Access: Write = 1 Read = 0
8	Parity bit: Odd parity on bits 15:9

When accessing memory (IRAM, ESFR, OTP, EEPROM, FIFO RAM, DEV RAM), the internal registers bits 15:13 must all be zero. If these bits are not zero, the SPI command is rejected and the SPI failure bit is set (see CheckByte below).

7.5.1.2 Transfer Width

Table 15 lists how the SPI transfer width (number of bytes) varies depending on whether the SPI is a read or write to the IRAM, ESFR, EEPROM, OTP, or FIFO data access.

Table 15. SPI Protocol Transfer Widths

MEMORY ACCESS MODE	REG ACCESS	MEMORY ACCESS	R/W	PARITY BIT	TYPE OF OPERATION	ADDRESS	DATA	DATA	TOTAL NO. OF BYTES
	Byte #1 (Breakdown)				Bytes				
	Bits 7:5	Bits 4:2	Bit 1	Bit 0	Byte #1 (Hex)	Byte #2	Byte #3	Byte #4	
Internal RAM write	000	100	1	1	13	8-bit RAM Address	8-bit Write Data	—	3
Internal RAM read	000	100	0	0	10	8-bit RAM Address	8-bit Don't Care	—	3
ESFR write	000	110	1	0	1A	8-bit ESFR Address	8-bit Write Data	—	3
ESFR read	000	110	0	1	19	8-bit ESFR Address	8-bit Don't Care	—	3
OTP write	000	001	1	1	07	OTP Address 15:8	OTP Address 7:0	8-bit write data	4
OTP read	000	001	0	0	04	OTP Address 15:8	OTP Address 7:0	8-bit don't care	4
EEPROM cache write	000	011	1	0	0E	8-bit EEPROM Address	8-bit Write Data	—	3
EEPROM cache read	000	011	0	1	0D	8-bit EEPROM Address	8-bit Don't Care	—	3
External RAM write	000	010	1	1	0B	EXTERNAL RAM Address 15:8	EXTERNAL Address 7:0	8-bit write data	4
External RAM read	000	010	0	0	08	EXTERNAL Address 15:8	EXTERNAL Address 7:0	8-bit don't care	3
DEV RAM write	000	111	1	1	1F	DEV RAM Address 15:8	DEV RAM Address 7:0	8-bit write data	4
DEV RAM read	000	111	0	0	1C	DEV RAM Address 15:8	DEV RAM Address 7:0	8-bit don't care	4
TEST write	000	101	1	0	16	8-bit TEST Address	8-bit Write Data	—	3
TEST read	000	101	0	1	15	8-bit TEST Address	8-bit Don't Care	—	3

For a SPI transfer to the internal register file, the parity *P* depends on the address.

For SPI transfers to the memories (IRAM, ESFR, OTP), the read data is available on the next SPI transfer. That is, when reading from a memory location, the user must send a subsequent transfer to get the data back.

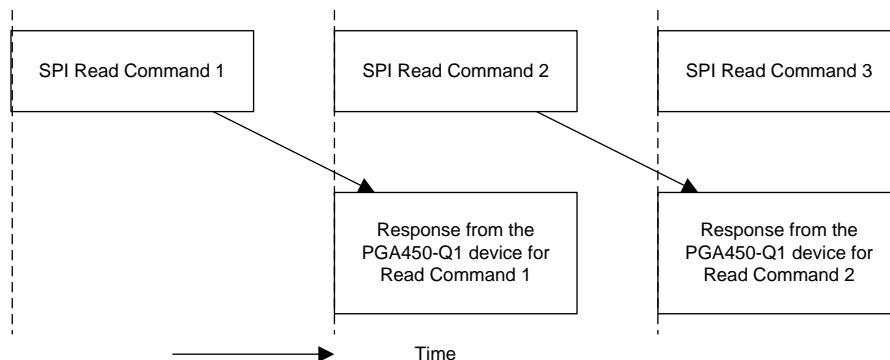

Figure 40. Response to SPI Read Commands Is Available When the Next Command Is Sent

7.5.1.3 CheckByte

On every SPI transfer, the PGA450-Q1 transmits a CheckByte which is in the 8 most significant bits of the transfer. For example, in a 16-bit transfer, the CheckByte is in bits 15:8 of the received data; similarly, for a 24 bit transfer the CheckByte is in bits 23:16 of the received data. The CheckByte can be used by the SPI master to detect SPI communication errors.

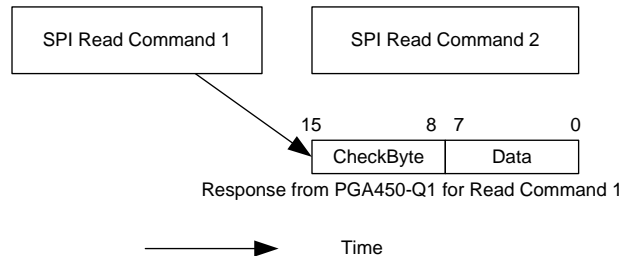

Figure 41. CheckByte Is Transmitted by PGA450-Q1 at the Beginning of Every Response

Table 16 lists the interpretation of each bit in the CheckByte transmitted by the PGA450-Q1.

For a successful SPI transfer, the CheckByte reads 8'h02. Bit 9 of the CheckByte is always set in order to assist debugging in the lab. If the SPI transfer failed for some reason, the most significant bit (15) of the CheckByte is set. The reason for the failure is then described in bits 14:11.

Table 16. SPI Protocol, CheckByte Field

CheckByte BIT	ERROR	DESCRIPTION
15 (or most significant bit)	SPI transfer failure	SPI transfer failure
14	Parity error	Parity error; command-byte parity incorrect
13	Illegal address	Illegal address; bits 15:13 and 12:10 cannot both be active
12	Illegal command	Illegal command; memory access bits 12:10 invalid
11	Wrong number of clocks	Wrong number clocks; must only receive 16, 24, or 32 clocks
10:8	Always 3'b010	Always 3'b010

7.5.1.4 Examples

Table 17 lists a few examples of SPI transfer:

Table 17. SPI Protocol Examples

COMMAND	SPI SLAVE TRANSFER
Read internal register 0 (revision id)	{{3'h0, 3'h0, 1'b0, 1'b1}, 8'hXX}
Write 0x80 to internal register 1 (MicroConfig)	{{3'h1, 3'h0, 1'b1, 1'b1}, 8'hC8}
Write 0x34 to internal RAM 0x7F	{{3'h0, 3'h4, 1'b1, 1'b1}, 8'h7F, 8'h34}
Read from ESFR 0xC0	{{3'h0, 3'h6, 1'b0, 1'b1}, 8'hC0}
Write 0xD9 to OTP 0x1765	{{3'h0, 3'h1, 1'b1, 1'b1}, 8'h17, 8'h65, 8'hD9}
Failed write 0xC8 to internal register 1 (bad parity)	{{3'h1, 3'h0, 1'b1, 1'b0}, 8'hC8}
Failed write 0xC8 to internal register 1 (illegal address)	{{3'h1, 3'h1, 1'b1, 1'b0}, 8'hC8}
Failed write 0x34 to memory (illegal command)	{{3'h0, 3'h7, 1'b1, 1'b1}, 8'h7F, 8'h34}

7.5.2 Diagnostics

7.5.2.1 Power-Block Monitors

The following operating-condition monitors have been implemented on the PGA450-Q1 to ensure reliable and robust performance over the lifetime of the device.

- VPWR overvoltage (greater than 28 V nominal, 20-µs deglitch time)
- VPWR level is such that AVDD is undervoltage (less than 6 V nominal, 2-ms deglitch time)

- AVDD overcurrent (greater than 55 mA nominal, 2-ms deglitch time)
- RBIAS overcurrent (greater than 63 μ A nominal, 2-ms deglitch time)

NOTE

Whenever these monitors sense a violation in the operating conditions, the microprocessor is held in reset.

A corresponding fault flag is also set in the STATUS1 register.

The fault flags are cleared when the fault condition is removed or when the device is reset.

7.5.2.2 Low-Side Diagnostics

The PGA450-Q1 has diagnostics implemented on the LS driver to protect the LS FET from sinking excessive currents when it is enabled. A fault condition is sensed if both the Vgs voltage and the Vds voltage on the LS FET remain above 2.5 V for the duration of either 1 μ s or 2 μ s (selectable by setting the LS_FAULT_TIMER_SEL bit in the CONTROL_1 register) during a turnon event. If a fault is sensed, the LS FET is immediately turned off and a corresponding flag is set in the STATUS2 register. The fault is automatically cleared when the LS FET is commanded to turn on in the next cycle.

The LS diagnostics are turned off by default and can be enabled by setting the LS_FAULT_LOGIC_EN bit in the CONTROL_1 register.

Figure 42 shows the schematic of the low-side drive and Figure 43 shows the timing diagram of the low-side diagnostics.

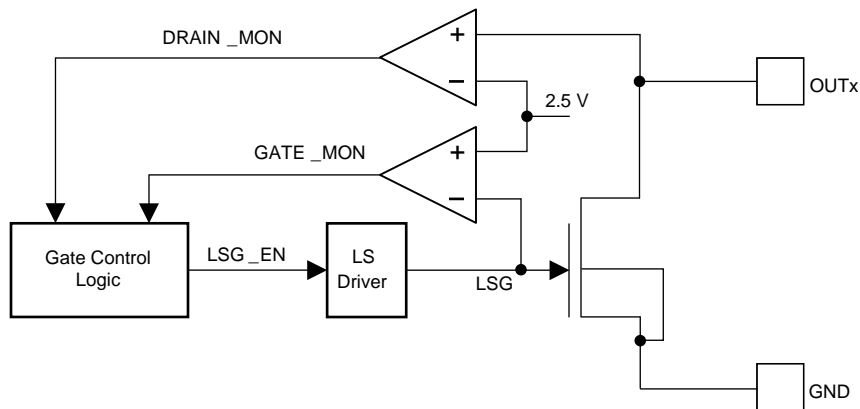
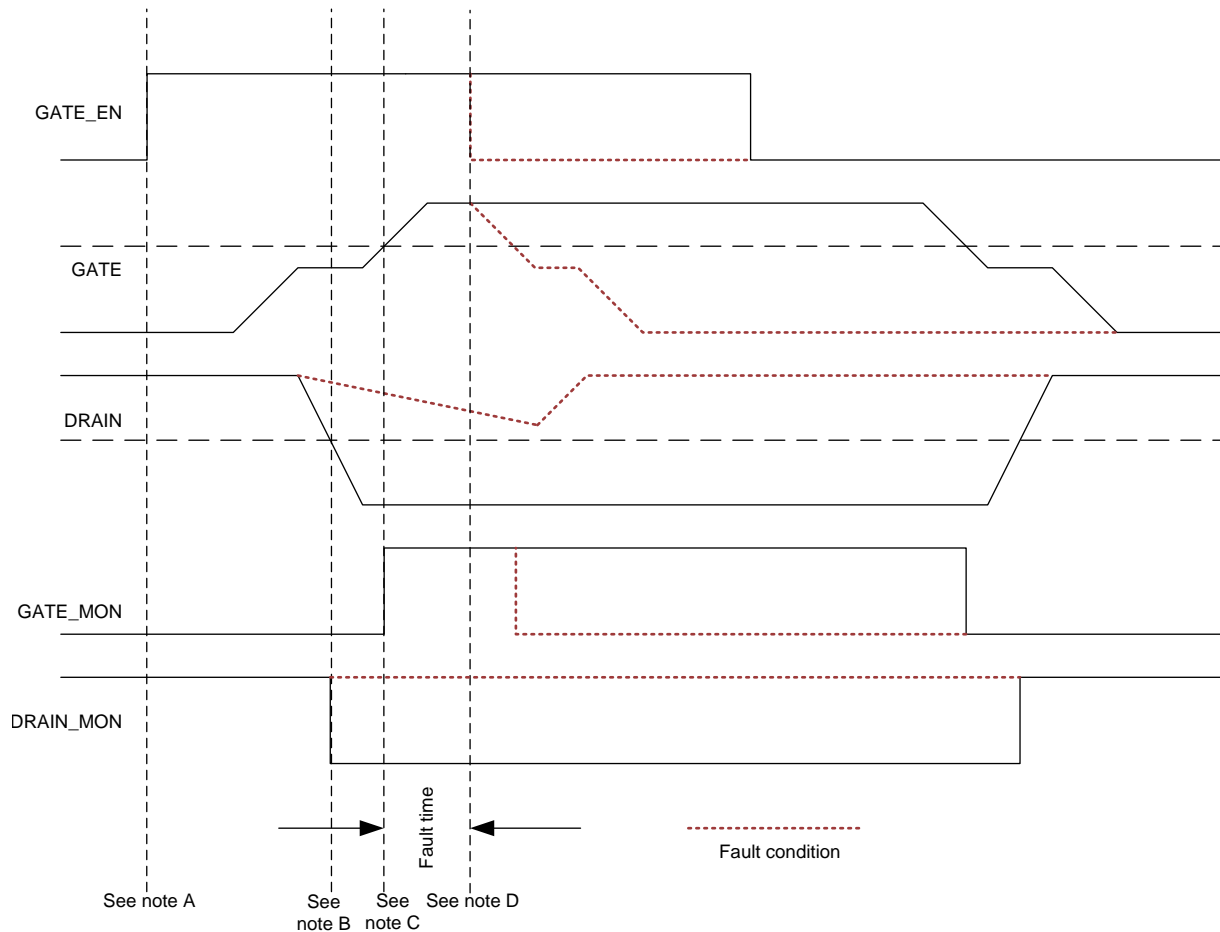

Figure 42. Low-Side Drive Schematic



- A. Gate is commanded on by LS driver logic. This 0 → 1 edge enables the LS fault diagnostic on the LS Driver if the LS_FAULT_LOGIC_EN is set.
- B. Drain monitor (DRAIN_MON) senses that drain is below 2.5 V for a normal scenario, whereas the drain monitor output remains high for the fault scenario.
- C. Gate monitor (GATE_MON) senses that gate is above 2.5 V.
- D. For the fault scenario, because GATE_MON and DRAIN_MON signals have remained high for the selected fault time (1 μ s or 2 μ s), a fault is sensed and the gate is immediately turned off.

Figure 43. Low-Side Fault Timing

7.5.2.3 Main Oscillator Watchdog

The PGA450-Q1 implements an internal free-running 500-kHz watchdog clock. This watchdog clock is used to monitor the internal 16-MHz main oscillator or the external crystal oscillator. When this frequency is outside this range, an internal reset is generated, which resets the entire digital core; this is equivalent to POR.

The main oscillator frequency fail limits have the following ranges as shown in [Figure 44](#):

- If the main oscillator frequency is less than 5.4 MHz, the watchdog logic recognizes this as a low-frequency fail and resets the digital core.
- If the main oscillator frequency lies in the range: 5.4 MHz < Main OSC Freq < 14 MHz, there is a possibility that the watchdog recognizes this as a low-frequency fail and resets the core, but reset is not assured.
- If the main oscillator frequency lies in the range: 14 MHz < Main Osc Freq < 18 MHz, the main osc watchdog does NOT reset the core, as this is seen as the nominal frequency of operation.
- If the main oscillator frequency lies in the range 18 MHz < Main Osc Freq < 43 MHz, there is a possibility that the watchdog recognizes this as a high-frequency fail and resets the core, but reset is not assured.
- If the main oscillator frequency is greater than 43 MHz, the watchdog logic recognizes this as a high-frequency fail and resets the digital core.

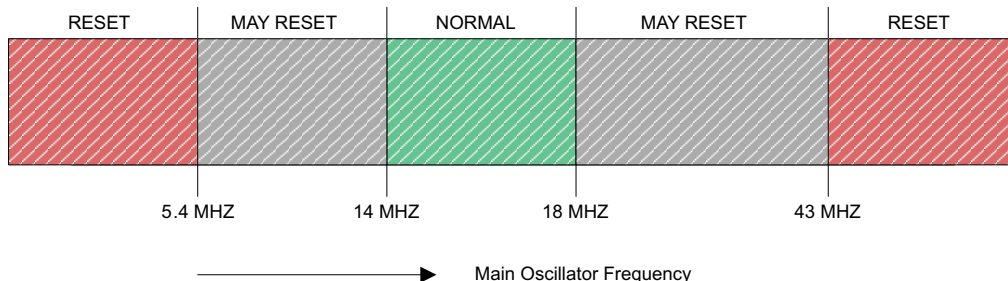

Figure 44. Main Oscillator Frequency and the Corresponding PGA450-Q1 Behavior

The main oscillator watchdog can be disabled using the OSC_WD_EN bit in the WD_EN register.

NOTE

A reset because of main oscillator watchdog failure causes an internal digital core reset. All ESFRs revert back to the reset state.

7.5.2.4 Software Watchdog

The PGA450-Q1 implements a software watchdog. This watchdog must be serviced by software every 250 ms. If the software does not service the watchdog within 250 ms of the last service, then the transducer drive FETs are turned OFF and the 8051W core is reset.

The software services the watchdog using port pin P3.7 as shown in Figure 45. The software services the watchdog by toggling the state of P3.7.

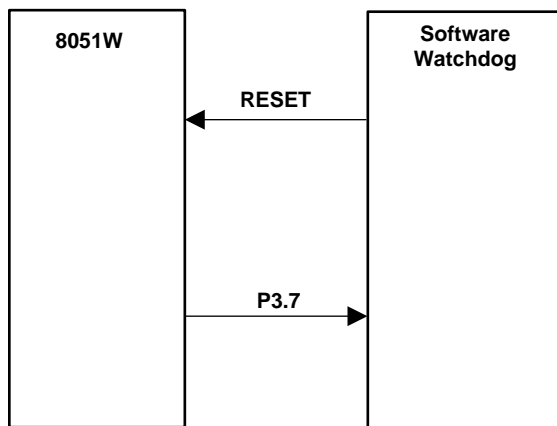

Figure 45. Connection Between the 8051W and the Software Watchdog

The software watchdog can be disabled using the SW_WD_EN bit in the WD_EN register. The following lists the behavior of this bit:

- The SW_WD_EN bit is in the disabled state after power-on reset (POR).
- If the 8051W is reset through the SPI, then SW_WD_EN is disabled.
- If SW_WD_EN is enabled and the 8051W is reset because the software watchdog has timed out, then SW_WD_EN remains enabled.

NOTE

A reset of the 8051W does not change the state of the ESFR registers. The ESFR registers continue to retain the state.

7.5.2.5 Internal ASIC TRIM Validity

The PGA450-Q1 has internal ASIC trim values. These trim values are used to fine-tune the operation of various blocks at TI manufacturing EOL.

The PGA450-Q1 checks the validity of these ASIC trim values after power up and before the 8051W reset is deasserted. If the internal trim values are not valid, the TRIM_FAIL bit in the STATUS1 register is set. The 8051W software can be used to check this bit after 8051W reset is deasserted and the software starts execution.

7.5.2.6 FIFO RAM and External SRAM MBIST

The PGA450-Q1 verifies the integrity of FIFO RAM and RAM in the external memory space (that is, all RAM in the external memory) with a RAM MBIST. The RAM MBIST begins immediately after POR is deasserted and takes approximately 5 ms. See [Figure 8](#) for power-up waveforms. The 8051W reset is deasserted while MBIST is ongoing.

MBIST sets the MBIST_DONE flag in STATUS1 upon completion of MBIST. The MBIST_FLAG is set to 1 if RAM MBIST fails.

NOTE

The 8051W microprocessor should not enable the digital datapath, should not access the FIFO RAM, and should not access RAM in the external memory space until the RAM MBIST DONE flag is set.

7.5.2.7 Thermal Shutdown

The PGA450-Q1 also has an overtemperature protection feature implemented. An overtemperature violation causes a total shutdown of the part with the microprocessor held in reset. When the device cools down below the overtemperature threshold, the device initiates a power up again.

7.5.3 8051W Interrupts

The MCU 8051 provides the five standard 8051-compatible *legacy* interrupts, plus expansion capability for a further nine *extended* interrupts sourced from external user logic. The standard and extended interrupts each have separate enable-register bits associated with them, allowing software control. The interrupts can also have two levels of priority assigned to them. The interrupts are defined as follows:

Standard interrupts The five standard interrupts comprise two timer overflow interrupts, an interrupt associated with the built-in serial interface of the core, and two external interrupts (referred to as *legacy* external interrupts).

Timer-overflow interrupts The two timer-overflow interrupts, TF0 and TF1, are set whenever their respective timers timer 0 and timer 1, roll over to zero. The states of these interrupts are also stored in the TCON register. The TF0 and TF1 interrupts are automatically cleared by hardware on entry to the corresponding interrupt service routine.

NOTE

All events on NINT0 and NINT1, whether level-triggered or edge-triggered, are detected by sampling the relevant interrupt line on the rising edge of SCLK at the end of phase 1 of every machine cycle. Where NINT0/NINT1 is level-triggered, a response is made to the signal being sampled low and, to ensure detection, the external source must hold the line low until the resulting interrupt is generated. (It also must ensure that the request is de-activated before the end of the associated service routine.) Where NINT0 or NINT1 is edge-triggered, the response is made to a transition on the signal from high to low between successive samples. This means that, to ensure detection, NINT0 or NINT1 must have been high for at least two clocks before it goes low and then must be held low for at least two clocks after this transition.

Serial interrupt The serial interrupts source comprises the logical OR of the two serial interface status bits RI and TI in register SCON. These interrupts are set automatically on receipt or transmission of a data frame. These two bits are not cleared by hardware.

Legacy external interrupts The two legacy external interrupts, NINT0 and NINT1, are driven from inputs PORT3(2) and PORT3(3), respectively. These interrupts can be either edge- or level-sensitive, depending on settings within the TCON register. Two further TCON register bits, IE0 and IE1, act as interrupt flags. If the external interrupt is set to edge-triggered, the corresponding register bit IE0 or IE1 is set by a falling edge on NINT0 or NINT1 and cleared by hardware on entry to the corresponding interrupt service routine. If the interrupt is set to be level-sensitive, IE0 or IE1 reflects the logic level on NINT0 or NINT1. The TCON register is described in the [Timer and Counter Control Register \(offset = 0x88\) \[reset = 0\]](#) section.

Extended interrupts Source and acknowledge signals are provided for a further nine interrupts. These interrupts are driven from external user logic, typically a user ESFR. The extended interrupts are input to the core on bits 5 to 13 of input bus XINTR_SRC, whereas acknowledge signals are output from the core on bits 5 to 13 of bus XINTR_ACK. *Note:* If the timers or the UART are omitted from the design, their corresponding interrupt inputs (plus those of the legacy external interrupts where the timers are omitted) are made available at the core periphery as XINTR_SRC[4:0], along with corresponding XINTR_ACK acknowledge signals, for use as additional extended interrupts.)

The extended-interrupt lines are sampled on the rising edge of PCLK at the beginning of phase 2 of the last cycle of the current instruction. To ensure detection, the external source must hold the XINTR_SRC line high until the resulting interrupt is generated and must also ensure that the request is deactivated before the end of the associated service routine.

Any edge-triggering that is required must be taken care of by individual peripherals.

NOTE

For additional information about these five standard interrupts, see the Intel 8-Bit Embedded Controller Handbook in the *Hardware Description of the 8051, 8052 and 80C51.*)

7.5.3.1 Interrupt Flag Clear

If the legacy external interrupts, NINT0 and NINT1, are edge-triggered, the interrupt flag is cleared on vectoring to the service routine. If these interrupts are level-triggered, the flag is controlled by the external signal. Timer and counter flags are cleared on vectoring to the interrupt service routine, but the serial interrupt flag is not affected by hardware. The serial interrupt flag should be cleared by software. Acknowledge signals are provided for clearing any registers used to source the nine additional interrupts.

7.5.3.2 Priority Levels and Interrupt Vectors

One of two priority levels can be selected for each interrupt. An interrupt of high priority may interrupt the service routine of a low-priority interrupt and, if two interrupts of different priority occur at the same time, the higher-level interrupt is serviced first. An interrupt cannot be interrupted by another interrupt of the same priority level. If two interrupts of the same priority level occur simultaneously, a polling sequence is observed as listed in [Table 18](#):

When an interrupt is serviced, a long call instruction is executed to one of the following locations, according to the source of the interrupt as listed in [Table 18](#).

Table 18. Interrupt Summary

8051W SOURCE	PGA450-Q1 SOURCE	VECTOR ADDRESS	POLLING SEQUENCE	FLAG	ENABLE	PRIORITY CONTROL
External interrupt 0	LIN RX	0x0003	1 (highest)	IE0 (TCON.1)	EX0 (IE.0)	PX0 (IP.0)
Timer and counter interrupt 0	←	0x000B	2	TF0 (TCON.5)	ET0 (IE.1)	PT0 (IP.1)
External interrupt 1	LIN ~RX	0x0013	3	IE1 (TCON.3)	EX1 (IE.2)	PX1 (IP.2)
Timer and counter interrupt 1	←	0x001B	4	TF1 (TCON.7)	ET1 (IE.3)	PT1 (IP.3)
Serial port 0	←	0x0023	5	RI_0 (SCON0.0)TI_0 (SCON0.1)	ES0 (IE.4)	PS0 (IP.4)
External interrupt 5	LIN PID received	0x002B	6	—	EI5 (IE.5)	PI5 (IP.5)
External interrupt 6	LIN/SCI DATA received	0x0033	7	—	EI6 (IE1.0)	PI6 (IP1.0)
External interrupt 7	LIN/SCI data transmit complete	0x003B	8	—	EI7 (IE1.1)	PI7 (IP1.1)
External interrupt 8	LIN SYNC received	0x0043	9	—	EI8 (IE1.2)	PI8 (IP1.2)
External interrupt 9		0x004B	10	—	EI9 (IE1.3)	PI9 (IP1.3)
External interrupt 10		0x0053	11	—	EI10 (IE1.4)	P10 (IP1.4)
External interrupt 11		0x005B	12	—	EI11 (IE1.5)	P11 (IP1.5)
External interrupt 12		0x0063	13	—	EI12 (IE1.6)	P12 (IP1.6)
External interrupt 13		0x006B	14 (Lowest)	—	EI13 (IE1.7)	P13 (IP.7)

7.5.3.3 Interrupt Latency

The response time in a single interrupt system is between 3 and 9 machine cycles.

7.5.4 Instructions

The M8051 Warp instruction set is listed in [Table 20](#). The following sections outline some of the supported features.

7.5.4.1 Addressing Modes

The M8051 Warp provides a variety of addressing modes, which are outlined as follows.

7.5.4.1.1 Direct Addressing

In direct addressing, the operand is specified by an 8-bit address field. Only internal data and SFRs can be accessed using this mode.

7.5.4.1.2 Indirect Addressing

In indirect addressing, the operand is specified by an address contained in a register. Two registers (R0 and R1) from the current bank or the data pointer can be used for addressing in this mode. Both internal and external data memory can be indirectly addressed.

7.5.4.1.3 Register Addressing

In register addressing, the operand is specified by the top 3 bits of the opcode, which selects one of the current bank of registers. Four banks of registers are available. The current bank is selected by bits 3 and 4 of the PSW.

7.5.4.1.4 Register Specific Addressing

Some instructions only operate on specific registers which is defined by the opcode. In particular, many accumulator operations and some stack pointer operations are defined in this manner.

7.5.4.1.5 Immediate Data

Instructions which use immediate data are 2 or 3 bytes long, and the immediate operand is stored in program memory as part of the instruction.

7.5.4.1.6 Indexed Addressing

Only program memory can be addressed using indexed addressing. This memory is intended for simple implementation of look-up tables. A 16-bit base register (either the PC or the DPTR) is combined with an offset stored in the accumulator to access data in program memory.

7.5.4.2 Arithmetic Instructions

The M8051 Warp implements ADD, ADDC (add with carry), SUBB (subtract with borrow), INC (increment), and DEC (decrement) functions, which can be used in most addressing modes. There are three accumulator-specific instructions, DA A (decimal adjust A), MUL AB (multiply A by B) and DIV AB (divide A by B).

7.5.4.3 Logical Instructions

The M8051 Warp implements ANL (AND logical), ORL (OR logical), and XRL (exclusive-OR logical) functions, which again can be used in most addressing modes. Seven accumulator-specific instructions are available, CLR A (clear A), CPL A (complement A), RL A (rotate left A), RLC A (rotate left through carry A), RR A (rotate right A), RRC A (rotate right through carry A), and SWAP A (swap nibbles of A).

7.5.4.4 Data Transfers

7.5.4.4.1 Internal Data Memory

Data can be moved from the accumulator to any internal data memory location, from any internal data memory location to the accumulator, and from any internal data memory location to any SFR or other internal data memory location.

7.5.4.4.2 External Data Memory

Data can be moved from the accumulator to or from an external memory location in one of two addressing modes. In 8-bit addressing mode, the external location is addressed by either R0 or R1; in 16-bit addressing mode, the location is addressed by the DPTR.

7.5.4.5 Jump Instructions

7.5.4.5.1 Unconditional Jumps

Four sorts of unconditional jump instructions are available. Short jumps (SJMP) are relative jumps (limited to –128 to 127 bytes), long jumps (LJMP) are absolute 16-bit jumps, and absolute jumps (AJMP) are absolute 11-bit jumps (that is, within a 2K byte memory page). The last type is an indexed jump, JMP @A+DPTR, which jumps to a location contained in the DPTR register, offset by a value stored in the accumulator.

7.5.4.5.2 Subroutine Calls and Returns

Only two sorts of subroutine call are available, ACALL and LCALL, which are absolute and long as previously described. Two return instructions are provided, RET and RETI. The latter is for interrupt service routines.

7.5.4.5.3 Conditional Jumps

Conditional jump instructions all use relative addressing and therefore are limited to the same –128- to 127-byte range as previously described.

7.5.4.6 Boolean Instructions

The bit-addressable registers in both the direct and SFR space can be manipulated using Boolean instructions. Logical functions are available which use the carry flag and an addressable bit as the operands and each addressable bit can be set, cleared, or tested in a jump instruction.

7.5.4.7 Flags

Table 19 lists the instructions that affect the flags generated by the ALU.

Table 19. Flag Summary

INSTRUCTION	FLAG			INSTRUCTION	FLAG		
	C	OV	AC		C	OV	AC
ADD	?	?	?	CLRC	0		
ADDC	?	?	?	CPLC	?		
SUBB	?	?	?	ANL C, bit	?		
MUL	0	?		ANL C, /bit	?		
DIV	0	?		ORL C, bit	?		
DA	?			ORL C, /bit	?		
RRC	?			MOV C, bit	?		
RLC	?			CJNE	?		
SETB C	1						

In Table 19, a 0 indicates that the flag is always cleared, a 1 indicates that the flag is always set, and a question mark (?) indicates that the state of the flag depends on the result of the operation. The flag specified as *blank* means that the state is unknown.

7.5.4.8 Instruction Table

Instructions are either 1, 2, or 3 bytes long as listed in the BYTES column of Table 20. Each instruction requires either 1, 2 or 4 machine cycles to execute as listed in Table 20. One machine cycle comprises 2 CCLK clock cycles.

Table 20. Instructions

MNEMONIC	DESCRIPTION	BYTES	CYCLES	HEX CODE
ARITHMETIC				
ADD A,Rn	Add register to A	1	1	28–2F
ADD A,dir	Add direct byte to A	2	1	25
ADD A,@Ri	Add indirect memory to A	1	1	26–27
ADD A,#data	Add immediate to A	2	1	24

Table 20. Instructions (continued)

MNEMONIC	DESCRIPTION	BYTES	CYCLES	HEX CODE
ADDC A,Rn	Add register to A with carry	1	1	38–3F
ADDC A,dir	Add direct byte to A with carry	2	1	35
ADDC A,@Ri	Add indirect memory to A with carry	1	1	36–37
ADDC A,#data	Add immediate to A with carry	2	1	34
SUBB A,Rn	Subtract register from A with borrow	1	1	98–9F
SUBB A,dir	Subtract direct byte from A with borrow	2	1	95
SUBB A,@Ri	Subtract indirect memory from A with borrow	1	1	96–97
SUBB A,#data	Subtract immediate from A with borrow			
INC A	Increment A	1	1	4
INC Rn	Increment register	1	1	08–0F
INC dir	Increment direct byte	2	1	5
INC @Ri	Increment indirect memory	1	1	06-07
DEC A	Decrement A	1	1	14
DEC Rn	Decrement register	1	1	18–1F
DEC dir	Decrement direct byte	2	1	15
DEC @Ri	Decrement indirect memory	1	1	16–17
INC DPTR	Increment data pointer	1	2	A3
MUL AB	Multiply A by B	1	4	A4
DIV AB	Divide A by B	1	4	84
DA A	Decimal Adjust A	1	1	D4
LOGICAL				
ANL A,Rn	AND register to A	1	1	58–5F
ANL A,dir	AND direct byte to A	2	1	55
ANL A,@Ri	AND indirect memory to A	1	1	56–57
ANL A,#data	AND immediate to A	2	1	54
ANL dir,A	AND A to direct byte	2	1	52
ANL dir,#data	AND immediate to direct byte	3	2	53
ORL A,Rn	OR register to A	1	1	48–4F
ORL A,dir	OR direct byte to A	2	1	45
ORL A,@Ri	OR indirect memory to A	1	1	46–47
ORL A,#data	OR immediate to A	2	1	44
ORL dir,A	OR A to direct byte	2	1	42
ORL dir,#data	OR immediate to direct byte	3	2	43
XRL A,Rn	Exclusive-OR register to A	1	1	68–6F
XRL A,dir	Exclusive-OR direct byte to A	2	1	65
XRL A,@Ri	Exclusive-OR indirect memory to A	1	1	66–67
XRL A,#data	Exclusive-OR immediate to A	2	1	64
XRL dir,A	Exclusive-OR A to direct byte	2	1	62
XRL dir,#data	Exclusive-OR immediate to direct byte	3	2	63
CLR A	Clear A	1	1	E4
CPL A	Complement A	1	1	F4
SWAP A	Swap Nibbles of A	1	1	C4
RL A	Rotate A left	1	1	23
RLC A	Rotate A left through carry	1	1	33
RR A	Rotate A right	1	1	3
RRC A	Rotate A right through carry	1	1	13

Table 20. Instructions (continued)

MNEMONIC	DESCRIPTION	BYTES	CYCLES	HEX CODE
DATA TRANSFER				
MOV A,Rn	Move register to A	1	1	E8–EF
MOV A,dir	Move direct byte to A	2	1	E5
MOV A,@Ri	Move indirect memory to A	1	1	E6–E7
MOV A,#data	Move immediate to A	2	1	74
MOV Rn,A	Move A to register	1	1	F8–FF
MOV Rn,dir	Move direct byte to register	2	2	A8–AF
MOV Rn,#data	Move immediate to register	2	1	78–7F
MOV dir,A	Move A to direct byte	2	1	F5
MOV dir,Rn	Move register to direct byte	2	2	88–8F
MOV dir,dir	Move direct byte to direct byte	3	2	85
MOV dir,@Ri	Move indirect memory to direct byte	2	2	86–87
MOV dir,#data	Move immediate to direct byte	3	2	75
MOV @Ri,A	Move A to indirect memory	1	1	F6–F7
MOV @Ri,dir	Move direct byte to indirect memory	2	2	A6–A7
MOV @Ri,#data	Move immediate to indirect memory	2	1	76–77
MOV DPTR,#data	Move immediate to data pointer	3	2	90
MOVC A,@A+DPTR	Move code byte relative DPTR to A	1	2	93
MOVC A,@A+PC	Move code byte relative PC to A	1	2	83
MOVX A,@Ri	Move external data(A8) to A	1	2	E2–E3
MOVX A,@DPTR	Move external data(A16) to A	1	2	E0
MOVX @Ri,A	Move A to external data(A8)	1	2	F2–F3
MOVX @DPTR,A	Move A to external data(A16)	1	2	F0
PUSH dir	Push direct byte onto stack	2	2	C0
POP dir	Pop direct byte from stack	2	2	D0
XCH A,Rn	Exchange A and register	1	1	C8–CF
XCH A,dir	Exchange A and direct byte	2	1	C5
XCH A,@Ri	Exchange A and indirect memory	1	1	C6–C7
XCHD A,@Ri	Exchange A and indirect memory nibble	1	1	D6–D7
BOOLEAN				
CLR C	Clear carry	1	1	C3
CLR bit	Clear direct bit	2	1	C2
SETB C	Set carry	1	1	D3
SETB bit	Set direct bit	2	1	D2
CPL C	Complement carry	1	1	B3
CPL bit	Complement direct bit	2	1	B2
ANL C,bit	AND direct bit to carry	2	2	82
ANL C,/bit	AND direct bit inverse to carry	2	2	B0
ORL C,bit	OR direct bit to carry	2	2	72
ORL C,/bit	OR direct bit inverse to carry	2	2	A0
MOV C,bit	Move direct bit to carry	2	1	A2
MOV bit,C	Move carry to direct bit	2	2	92
BRANCHING				
ACALL addr 11	Absolute jump to subroutine	2	2	11→F1
LCALL addr 16	Long jump to subroutine	3	2	12
RET	Return from subroutine	1	2	22
RETI	Return from interrupt	1	2	32

Table 20. Instructions (continued)

MNEMONIC	DESCRIPTION	BYTES	CYCLES	HEX CODE
AJMP addr 11	Absolute jump unconditional	2	2	01→E1
LJMP addr 16	Long jump unconditional	3	2	2
SJMP rel	Short jump (relative address)	2	2	80
JC rel	Jump on carry = 1	2	2	40
JNC rel	Jump on carry = 0	2	2	50
JB bit,rel	Jump on direct bit = 1	3	2	20
JNB bit,rel	Jump on direct bit = 0	3	2	30
JBC bit,rel	Jump on direct bit = 1 and clear	3	2	10
JMP @A+DPTR	Jump indirect relative DPTR	1	2	73
JZ rel	Jump on accumulator = 0	2	2	60
JNZ rel	Jump on accumulator ≠ 0	2	2	70
CJNE A,dir,rel	Compare A,direct jne relative	3	2	B5
CJNE A,#d,rel	Compare A,immediate jne relative	3	2	B4
CJNE Rn,#d,rel	Compare register, immediate jne relative	3	2	B8–BF
CJNE @Ri,#d,rel	Compare indirect, immediate jne relative	3	2	B6–B7
DJNZ Rn,rel	Decrement register, jnz relative	2	2	D8–DF
DJNZ dir,rel	Decrement direct byte, jnz relative	3	2	D5
MISCELLANEOUS				
NOP	No operation	1	1	0

In [Table 20](#), an entry such as E8–EF indicates a continuous block of hex opcodes used for 8 different registers, the register numbers of which are defined by the lowest three bits of the corresponding code. Non-continuous blocks of codes, shown as 11→F1 (for example), are used for absolute jumps and calls, with the top 3 bits of the code being used to store the top three bits of the destination address.

The CJNE instructions use the abbreviation #d for immediate data; other instructions use #data.

7.5.5 8051W Port Usage

The 8051W has four I/O ports. lists the port usage in the PGA450-Q1 device.

Table 21. 8051W I/O Port Usage in PGA450-Q1

PORT	BIT	USAGE IN PGA450-Q1
Port 0	0	OTP security
	1	OTP security
	2	OTP security
	3	OTP security
	4	OTP security
	5	OTP security
	6	OTP security
	7	OTP security
Port 1	0	
	1	
	2	
	3	
	4	
	5	
	6	
Port 2	7	
	0	Low side A

Table 21. 8051W I/O Port Usage in PGA450-Q1 (continued)

PORT	BIT	USAGE IN PGA450-Q1
	1	Low side B
	2	
	3	LIN Tx
	4	
	5	
	6	
	7	
Port 3	0	UART Rx/D
	1	UART Tx/D
	2	LIN Rx/external interrupt input 0, active-low
	3	~LIN Rx/external interrupt input 1, active-low
	4	GPIO1/Timer 0 external input
	5	GPIO2/Timer 1 external input
	6	
	7	Software watchdog

7.6 Register Maps

The memory block consists of SRAM, OTP, and EEPROM. The SRAM is used as storage for volatile software variables during program execution. The OTP consists of the program code and the EEPROM consists of calibrations.

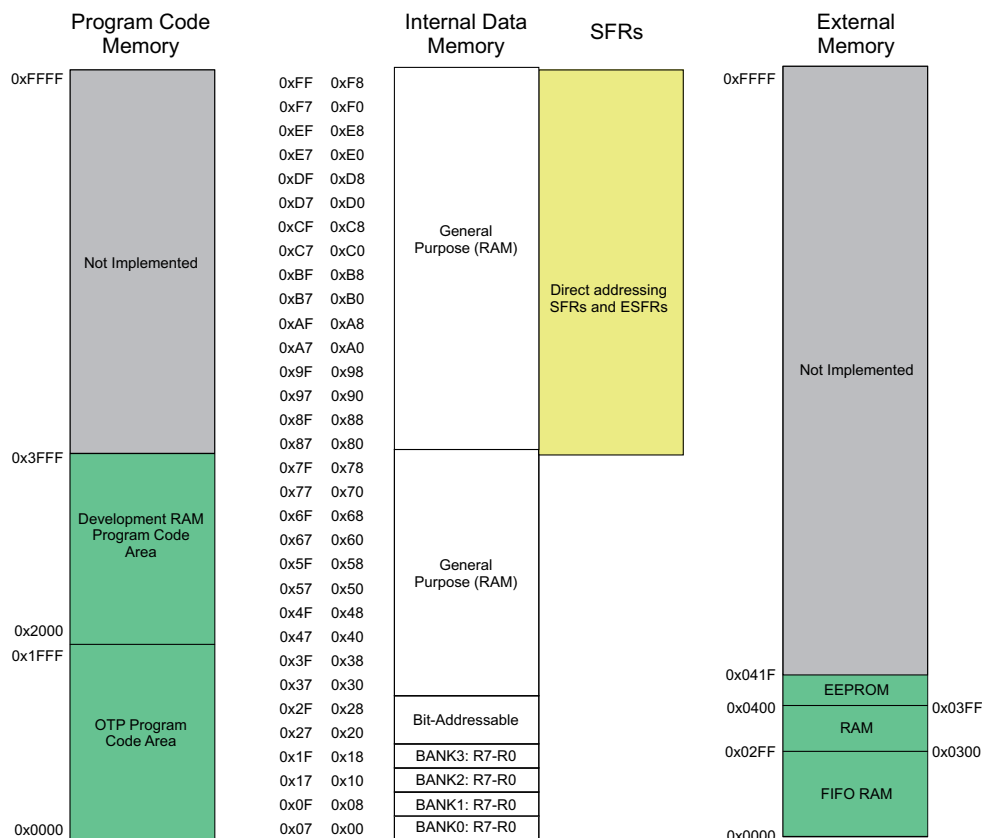

Figure 46. PGA450 Memory Map

Table 22. SFR Memory Map

Address (hex)	Description	D6	D5	D4	D3	D2	D1	D0	R/W	POWER ON Value	
80	Port 0 (P0)	P0[6]	P0[5]	P0[4]	P0[3]	P0[2]	P0[1]	P0[0]	R/W	0xFF	
81	Stack Pointer	SP[6]	SP[5]	SP[4]	SP[3]	SP[2]	SP[1]	SP[0]	R/W	0	
82	Data Pointer Low Byte	DPTR[6]	DPTR[5]	DPTR[4]	DPTR[3]	DPTR[2]	DPTR[1]	DPTR[0]	R/W	0	
83	Data Pointer High Byte	DPTR[14]	DPTR[13]	DPTR[12]	DPTR[11]	DPTR[10]	DPTR[9]	DPTR[8]	R/W	0	
87	Power control Register				GF1	GF0	PD	IDL	R/W	0	
88	Timer / Counter Control	TR1	TF0	TR0	IE1	IT1	IE0	IT0	R/W	0	
89	Timer / Counter Mode	CNT1	M1 (1)	M0 (1)	GATE0	CNT0	M1 (0)	M0 (0)	R/W	0	
8A	Timer / Counter Data (TL0)	TL0[6]	TL0[5]	TL0[4]	TL0[3]	TL0[2]	TL0[1]	TL0[0]	R/W	0	
8B	Timer / Counter Data (TL1)	TL1[6]	TL1[5]	TL1[4]	TL1[3]	TL1[2]	TL1[1]	TL1[0]	R/W	0	
8C	Timer / Counter Data (TH0)	TH0[6]	TH0[5]	TH0[4]	TH0[3]	TH0[2]	TH0[1]	TH0[0]	R/W	0	
8D	Timer / Counter Data (TH1)	TH1[6]	TH1[5]	TH1[4]	TH1[3]	TH1[2]	TH1[1]	TH1[0]	R/W	0	
90	Port 1 (P1)	P1[6]	P1[5]	P1[4]	P1[3]	P1[2]	P1[1]	P1[0]	R/W	0xFF	
98	UART Control (SCON)	SM1	SM2	REN	TB8	RB8	TI	RI	R/W	0	
99	UART Data (SBUF)	SBUF[6]	SBUF[5]	SBUF[4]	SBUF[3]	SBUF[2]	SBUF[1]	SBUF[0]	R/W	0	
A0	Port 2 (P2)	P2[6]	P2[5]	P2[4]	P2[3]	P2[2]	P2[1]	P2[0]	R/W	0xFF	
A8	Interrupt Enable Register 0			EI5	ES	ET1	EX1	ET0	EX0	R/W	0
B0	Port 3 (P3)	P3[6]	P3[5]	P3[4]	P3[3]	P3[2]	P3[1]	P3[0]	R/W	0xFF	
B8	Interrupt Priority Register 0			PI5	PS	PT1	PX1	PT0	PX0	R/W	0
D0	Program Status Word	AC	F0	RS1	RS0	OV	F1	P	R/W	0	
E0	Accumulator	ACC[6]	ACC[5]	ACC[4]	ACC[3]	ACC[2]	ACC[1]	ACC[0]	R/W	0	
E8	Interrupt Enable Register 1	EI12	EI11	EI10	EI9	EI8	EI7	EI6	R/W	0	
F0	Register (B)	B[6]	B[5]	B[4]	B[3]	B[2]	B[1]	B[0]	R/W	0	
F8	Interrupt Priority Register 1	PI12	PI11	PI10	PI9	PI8	PI7	PI6	R/W	0	

Table 23. ESFR Memory Map

Address (hex)	D7	D6	D5	D4	D3	D2	D1	D0	R/W	Power Up	Description (Programmable Regs)
92	BPF_B1[15]	BPF_B1[14]	BPF_B1[13]	BPF_B1[12]	BPF_B1[11]	BPF_B1[10]	BPF_B1[9]	BPF_B1[8]	R/W	0	BPF_B1_MSB
93	BPF_B1[7]	BPF_B1[6]	BPF_B1[5]	BPF_B1[4]	BPF_B1[3]	BPF_B1[2]	BPF_B1[1]	BPF_B1[0]	R/W	0	BPF_B1_LSB
94	BPF_A2[15]	BPF_A2[14]	BPF_A2[13]	BPF_A2[12]	BPF_A2[11]	BPF_A2[10]	BPF_A2[9]	BPF_A2[8]	R/W	0	BPF_A2_MSB
95	BPF_A2[7]	BPF_A2[6]	BPF_A2[5]	BPF_A2[4]	BPF_A2[3]	BPF_A2[2]	BPF_A2[1]	BPF_A2[0]	R/W	0	BPF_A2_LSB
96	BPF_A3[15]	BPF_A3[14]	BPF_A3[13]	BPF_A3[12]	BPF_A3[11]	BPF_A3[10]	BPF_A3[9]	BPF_A3[8]	R/W	0	BPF_A3_MSB
97	BPF_A3[7]	BPF_A3[6]	BPF_A3[5]	BPF_A3[4]	BPF_A3[3]	BPF_A3[2]	BPF_A3[1]	BPF_A3[0]	R/W	0	BPF_A3_LSB
A1		LPF_B1[14]	LPF_B1[13]	LPF_B1[12]	LPF_B1[11]	LPF_B1[10]	LPF_B1[9]	LPF_B1[8]	R/W	0	LPF_B1_MSB
A2	LPF_B1[7]	LPF_B1[6]	LPF_B1[5]	LPF_B1[4]	LPF_B1[3]	LPF_B1[2]	LPF_B1[1]	LPF_B1[0]	R/W	0	LPF_B1_LSB
A3		LPF_A2[14]	LPF_A2[13]	LPF_A2[12]	LPF_A2[11]	LPF_A2[10]	LPF_A2[9]	LPF_A2[8]	R/W	0	LPF_A2_MSB
A4	LPF_A2[7]	LPF_A2[6]	LPF_A2[5]	LPF_A2[4]	LPF_A2[3]	LPF_A2[2]	LPF_A2[1]	LPF_A2[0]	R/W	0	LPF_A2_LSB
A5			DS5	DS4	DS3	DS2	DS1	DS0	R/W	0	DOWNSAMPLE
A6						ONA[10]	ONA[9]	ONA[8]	R/W	0	ONA_MSB
A7	ONA[7]	ONA[6]	ONA[5]	ONA[4]	ONA[3]	ONA[2]	ONA[1]	ONA[0]	R/W	0	ONA_LSB
A9						OFFA[10]	OFFA[9]	OFFA[8]	R/W	0	OFFA_MSB
AA	OFFA[7]	OFFA[6]	OFFA[5]	OFFA[4]	OFFA[3]	OFFA[2]	OFFA[1]	OFFA[0]	R/W	0	OFFA_LSB
AB						ONB[10]	ONB[9]	ONB[8]	R/W	0	ONB_MSB
AC	ONB[7]	ONB[6]	ONB[5]	ONB[4]	ONB[3]	ONB[2]	ONB[1]	ONB[0]	R/W	0	ONB_LSB
AD						OFFB[10]	OFFB[9]	OFFB[8]	R/W	0	OFFB_MSB
AE	OFFB[7]	OFFB[6]	OFFB[5]	OFFB[4]	OFFB[3]	OFFB[2]	OFFB[1]	OFFB[0]	R/W	0	OFFB_LSB
AF			PCA5	PCA4	PCA3	PCA2	PCA1	PCA0	R/W	0	PULSE_CNTA
B1			PCB5	PCB4	PCB3	PCB2	PCB1	PCB0	R/W	0	PULSE_CNTB
B2	DT7	DT6	DT5	DT4	DT3	DT2	DT1	DT0	R/W	0	DEADTIME
B3						BMODE2	BMODE1	BMODE0	R/W	0	BURST_MODE
B4	TS7	TS6	TS5	TS4	TS3	TS2	TS1	TS0	R	0	TEMP_SENS
B5	SD7	SD6	SD5	SD4	SD3	SD2	SD1	SD0	R/W	0	SAT_DEGLITCH
B6	ST7	ST6	ST5	ST4	ST3	ST2	ST1	ST0	R	0	SAT_TIME
B7			LS_FAULT_LOG_IC_EN	LS_FAULT_TIMER_SEL	LNA_GAIN1	LNA_GAIN0	SAT_SEL1	SAT_SEL0	R/W	0	CONTROL_1
B9	BT7	BT6	BT5	BT4	BT3	BT2	BT1	BT0	R/W	0	BLANKING_TIMER
BA	FRT[15]	FRT[14]	FRT[13]	FRT[12]	FRT[11]	FRT[10]	FRT[9]	FRT[8]	R	0	FRT_MSB
BB	FRT[7]	FRT[6]	FRT[5]	FRT[4]	FRT[3]	FRT[2]	FRT[1]	FRT[0]	R	0	FRT_LSB
BC	MICRO_LIN_TX	UARTTX_CONFIG	GPIO2_CONFIG2	GPIO2_CONFIG1	GPIO2_CONFIG0	GPIO1_CONFIG2	GPIO1_CONFIG1	GPIO1_CONFIG0	R/W	0	GPIO_CTRL
BD							CLK_SEL1	CLK_SEL0	R/W	0	CLK_SEL
BE							SW_WD_EN	OSC_WD_EN	R/W	0	WD_EN
BF								LIN_SCI	R/W	0	LIN_SCI
C0							RELOAD	WRITE/EE_STATUS	R/W	0	EE_CTRL
C1		TRIM_FAIL	MBIST_DONE	MBIST_FAIL	VPWR_OV	AVDD_UV	AVDD_OC	RBIAS_OC	R	N/A	STATUS1
C2			WD_TO_OSC	LSB_FAULT	LSA_FAULT	WD_TO_SW	SAT_DONE	VREG_READY	R	N/A	STATUS2

Table 23. ESFR Memory Map (continued)

Address (hex)	D7	D6	D5	D4	D3	D2	D1	D0	R/W	Power Up	Description (Programmable Regs)	
C3							VREG_EN	ACTIVE_EN		R/W	0	PWR_MODE
C4						FIFO_ADC	SCI_TX_EN	FIFO_PEAKDET		R/W	0	DP_SCI_CTRL
C5						NROLLOVER	FMODE1	FMODE0		R/W	0	FIFO_CTRL
C8	CAP_FR_TIMER				ECHO_EN	SAT_EN	BURST_B_EN	BURST_EN		R	N/A	EN_CTRL
C9	RX_DATA1[7]	RX_DATA1[6]	RX_DATA1[5]	RX_DATA1[4]	RX_DATA1[3]	RX_DATA1[2]	RX_DATA1[1]	RX_DATA1[0]		R	N/A	RX_DATA1
CA	RX_DATA2[7]	RX_DATA2[6]	RX_DATA2[5]	RX_DATA2[4]	RX_DATA2[3]	RX_DATA2[2]	RX_DATA2[1]	RX_DATA2[0]		R	N/A	RX_DATA2
CB	RX_DATA3[7]	RX_DATA3[6]	RX_DATA3[5]	RX_DATA3[4]	RX_DATA3[3]	RX_DATA3[2]	RX_DATA3[1]	RX_DATA3[0]		R	N/A	RX_DATA3
CC	RX_DATA4[7]	RX_DATA4[6]	RX_DATA4[5]	RX_DATA4[4]	RX_DATA4[3]	RX_DATA4[2]	RX_DATA4[1]	RX_DATA4[0]		R	N/A	RX_DATA4
CD	RX_DATA5[7]	RX_DATA5[6]	RX_DATA5[5]	RX_DATA5[4]	RX_DATA5[3]	RX_DATA5[2]	RX_DATA5[1]	RX_DATA5[0]		R	N/A	RX_DATA5
CE	RX_DATA6[7]	RX_DATA6[6]	RX_DATA6[5]	RX_DATA6[4]	RX_DATA6[3]	RX_DATA6[2]	RX_DATA6[1]	RX_DATA6[0]		R	N/A	RX_DATA6
CF	RX_DATA7[7]	RX_DATA7[6]	RX_DATA7[5]	RX_DATA7[4]	RX_DATA7[3]	RX_DATA7[2]	RX_DATA7[1]	RX_DATA7[0]		R	N/A	RX_DATA7
D1	RX_DATA8[7]	RX_DATA8[6]	RX_DATA8[5]	RX_DATA8[4]	RX_DATA8[3]	RX_DATA8[2]	RX_DATA8[1]	RX_DATA8[0]		R	N/A	RX_DATA8
D2	PID7	PID6	PID5	PID4	PID3	PID2	PID1	PID0		R	N/A	LIN_PID
D3	TX_DATA1[7]	TX_DATA1[6]	TX_DATA1[5]	TX_DATA1[4]	TX_DATA1[3]	TX_DATA1[2]	TX_DATA1[1]	TX_DATA1[0]		R/W	N/A	TX_DATA1
D4	TX_DATA2[7]	TX_DATA2[6]	TX_DATA2[5]	TX_DATA2[4]	TX_DATA2[3]	TX_DATA2[2]	TX_DATA2[1]	TX_DATA2[0]		R/W	N/A	TX_DATA2
D5	TX_DATA3[7]	TX_DATA3[6]	TX_DATA3[5]	TX_DATA3[4]	TX_DATA3[3]	TX_DATA3[2]	TX_DATA3[1]	TX_DATA3[0]		R/W	N/A	TX_DATA3
D6	TX_DATA4[7]	TX_DATA4[6]	TX_DATA4[5]	TX_DATA4[4]	TX_DATA4[3]	TX_DATA4[2]	TX_DATA4[1]	TX_DATA4[0]		R/W	N/A	TX_DATA4
D7	TX_DATA5[7]	TX_DATA5[6]	TX_DATA5[5]	TX_DATA5[4]	TX_DATA5[3]	TX_DATA5[2]	TX_DATA5[1]	TX_DATA5[0]		R/W	N/A	TX_DATA5
D8	TX_DATA6[7]	TX_DATA6[6]	TX_DATA6[5]	TX_DATA6[4]	TX_DATA6[3]	TX_DATA6[2]	TX_DATA6[1]	TX_DATA6[0]		R/W	N/A	TX_DATA6
D9	TX_DATA7[7]	TX_DATA7[6]	TX_DATA7[5]	TX_DATA7[4]	TX_DATA7[3]	TX_DATA7[2]	TX_DATA7[1]	TX_DATA7[0]		R/W	N/A	TX_DATA7
DA	TX_DATA8[7]	TX_DATA8[6]	TX_DATA8[5]	TX_DATA8[4]	TX_DATA8[3]	TX_DATA8[2]	TX_DATA8[1]	TX_DATA8[0]		R/W	N/A	TX_DATA8
DB					CNT3	CNT2	CNT1	CNT0		R/W	N/A	DATA_CNT
DC	BIT_TOL	CS_METHOD	CLR_ERR	INTERBYTE_SP C	HOLD			IGNORE_DIAG		R/W	0x40	LIN_CFG
DD								RX_TX		R/W	N/A	LIN_CTRL
DE		BREAK_DEL	SYNC_LONG	SYNC_SHORT	STOP_BIT_SHO RT	STOP_BIT_VAL	PARITY	CHECKSUM		R	N/A	LIN_STATUS
DF							FIFO_PTR[9]	FIFO_PTR[8]		R/W	N/A	FIFO_POINTER_MSB
E1	FIFO_PTR[7]	FIFO_PTR[6]	FIFO_PTR[5]	FIFO_PTR[4]	FIFO_PTR[3]	FIFO_PTR[2]	FIFO_PTR[1]	FIFO_PTR[0]		R	N/A	FIFO_POINTER_LSB
E2					VREG_SEL3	VREG_SEL2	VREG_SEL1	VREG_SEL0		R/W	0	VREG_SEL
E3	SC[15]	SC[14]	SC[13]	SC[12]	SC[11]	SC[10]	SC[9]	SC[8]		R/W	0	SYNC_COUNT_MSB
E4	SC[7]	SC[6]	SC[5]	SC[4]	SC[3]	SC[2]	SC[1]	SC[0]		R/W	0	SYNC_COUNT_LSB
E5							TS_DAC_MODE	TS_DAC_EN		R/W	0	TEMP_DAC_CTRL
E6		OVR	OS5	OS4	OS3	OS2	OS1	OS0		R/W	0	OSC_SYNC_CTRL
E9					AMUX3	AMUX2	AMUX1	AMUX0		R/W	0	ANALOG_MUX
EA				DMUX4	DMUX3	DMUX2	DMUX1	DMUX0		R/W	0	DIGITAL_MUX

7.6.1 SFR Registers

7.6.1.1 I/O Ports (P0, P1, P2, P3) Registers

P0, P1, P2, and P3 are latches used to drive the 32 quasi-bidirectional I/O lines. On reset, these registers are all set to the value FF hex, which is input mode. [Table 21](#) lists the port usage in the PGA450-Q1 device.

7.6.1.1.1 I/O Port 3 Register (offset = 0xB0) [reset = 0xFF]

Bit addressable

Figure 47. I/O Port 3 (P3) Register

7	6	5	4	3	2	1	0
P3[7]	P3[6]	P3[5]	P3[4]	P3[3]	P3[2]	P3[1]	P3[0]
R/W-1	R/W-1	R/W-1	R/W-1	R/W-1	R/W-1	W-1	R-1

Table 24. P3 Register Field Descriptions

Bit	Field	Type	Reset	Description
7	P3[7]	R/W	1	
6	P3[6]	R/W	1	
5	P3[5]	R/W	1	This bit has an alternate function as a T1 input
4	P3[4]	R/W	1	This bit has an alternate function as a T0 input
3	P3[3]	R/W	1	This bit has an alternate function as an NINT1 input
2	P3[2]	R/W	1	This bit has an alternate function as an NINT0 input
1	P3[1]	W	1	This bit has an alternate function as a TXD output. When functioning as a TXD output, this bit serial transmits data from the UART and transmit clock in UART mode 0.
0	P3[0]	R	1	This bit has an alternate function as a RXD input. When functioning as a RXD input, this bit serial receives data to the UART.

7.6.1.1.2 I/O Port 2 Register (offset = 0xA0) [reset = 0xFF]

Figure 48. I/O Port 2 (P2)

7	6	5	4	3	2	1	0
P2[7]	P2[6]	P2[5]	P2[4]	P2[3]	P2[2]	P2[1]	P2[0]
R/W-1	R/W-1	R/W-1	R/W-1	R/W-1	R/W-1	R/W-1	R/W-1

Table 25. P2 Register Field Descriptions

Bit	Field	Type	Reset	Description
7-0	P2[7:0]	R/W	1	

7.6.1.1.3 I/O Port 1 Register (offset = 0x90) [reset = 0xFF]

Figure 49. I/O Port 1 (P1) Register

7	6	5	4	3	2	1	0
P1[7]	P1[6]	P1[5]	P1[4]	P1[3]	P1[2]	P1[1]	P1[0]
R/W-1	R/W-1	R/W-1	R/W-1	R/W-1	R/W-1	R/W-1	R/W-1

Table 26. P1 Register Field Descriptions

Bit	Field	Type	Reset	Description
7-0	P1[7:0]	R/W	1	

7.6.1.1.4 I/O Port 0 (P0) (offset = 0x80) [reset = 0xFF]
Figure 50. I/O Port 0 (P0) Register

7	6	5	4	3	2	1	0
P0[7]	P0[6]	P0[5]	P0[4]	P0[3]	P0[2]	P0[1]	P0[0]
R/W-1	R/W-1	R/W-1	R/W-1	R/W-1	R/W-1	R/W-1	R/W-1

Table 27. P0 Register Field Descriptions

Bit	Field	Type	Reset	Description
7-0	P0[7:0]	R/W	1	

7.6.1.2 Stack Pointer Register (offset = 0x81) [reset = 0]

Not bit-addressable

The SP register contains the stack pointer. The stack pointer is used to load the program counter into internal data memory during LCALL and ACALL instructions and is used to retrieve the program counter from memory during RET and RETI instructions. Data can also be saved on or retrieved from the stack using PUSH and POP instructions. Instructions that use the stack automatically pre-increment or post-decrement the stack pointer so that the stack pointer always points to the last byte written to the stack, that is, the top of the stack. On reset the stack pointer is set to 07h. The user must ensure that the location of the stack in internal data memory does not interfere with other data stored therein.

Another use of the scratchpad area is for the programmer stack. This area is selected using the stack pointer (SP, SFR 81h). Whenever a call or interrupt is invoked, the return address is placed on the stack. The stack is also available to the user for variables, and so forth, because the stack can be moved and there is no fixed location within the RAM designated as stack. The stack pointer defaults to 07h on reset, and the user can then move it as needed. The SP points to the last used value. Therefore, the next value placed on the stack is put at SP + 1. Each PUSH or CALL increments the SP by the appropriate value, and each POP or RET decrements it.

Figure 51. Stack Pointer (SP) Register

7	6	5	4	3	2	1	0
SP[7]	SP[6]	SP[5]	SP[4]	SP[3]	SP[2]	SP[1]	SP[0]
R/W-0	R/W-0	R/W-0	R/W-0	R/W-0	R/W-1	R/W-1	R/W-1

Table 28. SP Register Field Descriptions

Bit	Field	Type	Reset	Description
7-0	SP[7:0]	R/W	0	

7.6.1.3 Data Pointer Registers

Not bit-addressable.

The data pointer (DPTR) is a 16-bit register that may be accessed through the two SFR locations, data-pointer high byte (DPH) and data-pointer low byte (DPL). Two true 16-bit operations are allowed on the data pointer, load immediate and increment. The data pointer is used to form 16-bit addresses for external data memory accesses (MOVX), for program byte moves (MOVC) and for indirect program jumps (JMP @A+DPTR). On reset, the data pointer is set to 0000h.

7.6.1.3.1 Data Pointer Register (offset = 0x82) [reset = 0]

This is the 8 LSB of the data pointer.

Figure 52. Data Pointer (DPL) Register

7	6	5	4	3	2	1	0
DPTR[7]	DPTR[6]	DPTR[5]	DPTR[4]	DPTR[3]	DPTR[2]	DPTR[1]	DPTR[0]
R/W-0	R/W-0	R/W-0	R/W-0	R/W-0	R/W-0	R/W-0	R/W-0

Table 29. DPL Register Field Descriptions

Bit	Field	Type	Reset	Description
7-0	DPTR[7:0]	R/W	0	

7.6.1.3.2 Data Pointer Register (offset = 0x83) [reset = 0]

This is the 8 MSB of the data pointer.

Figure 53. Data Pointer (DPH) Register

7	6	5	4	3	2	1	0
DPTR[15]	DPTR[14]	DPTR[13]	DPTR[12]	DPTR[11]	DPTR[10]	DPTR[9]	DPTR[8]
R/W-0	R/W-0	R/W-0	R/W-0	R/W-0	R/W-0	R/W-0	R/W-0

Table 30. DPH Register Field Descriptions

Bit	Field	Type	Reset	Description
7-0	DPTR[15:8]	R/W	0	

7.6.1.4 Power Control Register (offset = 0x87) [reset = 0]

Not bit-addressable.

Figure 54. Power Control (PCON) Register

7	6	5	4	3	2	1	0
SMOD		—		GF[1:0]		PD	IDL
R/W-0		R-0		R/W-0		R/W-0	R/W-0

Table 31. PCON Register Field Descriptions

Bit	Field	Type	Reset	Description
7	SMOD	R/W	0	Double baud rate bit. For use, see Table 40 .
6-4		R	0	
3-2	GF[1:0]	R/W	0	General-purpose flag bit
1	PD	R/W	0	Power-down bit. If 1, power-down mode is entered.
0	IDL	R/W	0	Idle bit. If 1, idle mode is entered.

7.6.1.5 Timer and Counter Control Register (offset = 0x88) [reset = 0]

Bit Addressable.

Two 16-bit timer and counters are provided. The TCON and TMOD bits are used to set the mode of operation and to control the running and interrupt generation of the timer and counters. The timer and counter values are stored in two pairs of 8-bit registers (TL0, TH0, TL1, and TH1).

Figure 55. Timer and Counter Control (TCON) Register

7	6	5	4	3	2	1	0
TF1	TR1	TF0	TR0	IE1	IT1	IE0	IT0
R/W-0	R/W-0	R/W-0	R/W-0	R/W-0	R/W-0	R/W-0	R/W-0

Table 32. TCON Register Field Descriptions

Bit	Field	Type	Reset	Description
7	TF1	R/W	0	Timer 1 overflow flag. Set by hardware when timer and counter 1 overflows. Cleared by hardware when the processor calls the interrupt service routine.
6	TR1	R/W	0	Timer 1 run control. If 1, timer runs; if 0, timer is halted.
5	TF0	R/W	0	Timer 0 overflow flag. Set by hardware when timer and counter 0 overflows. Cleared by hardware when the processor calls the interrupt service routine.
4	TR0	R/W	0	Timer 0 run control. If 1, timer runs; if 0, timer is halted.
3	IE1	R/W	0	External Interrupt 1 edge flag. Set by hardware when an external interrupt 1 edge is detected.
2	IT1	R/W	0	External Interrupt 1 control bit. If 1, external interrupt 1 is edge-triggered; if 0, external interrupt 1 is level-triggered.
1	IE0	R/W	0	External Interrupt 0 edge flag. Set by hardware when an external interrupt 0 edge is detected.
0	IT0	R/W	0	External Interrupt 0 control bit. If 1, external interrupt 0 is edge-triggered; if 0, external interrupt 0 is level-triggered.

7.6.1.6 Timer and Counter Mode Register (offset = 0x89) [reset = 0]

Not Bit Addressable.

Figure 56. Timer and Counter Mode (TMOD) Register

7	6	5	4	3	2	1	0
GATE1	CNT1	M1 (1)	M0 (1)	GATE0	CNT0	M1 (0)	M0 (0)
R/W-0	R/W-0	R/W-0	R/W-0	R/W-0	R/W-0	R/W-0	R/W-0

Table 33. TMOD Register Field Descriptions

Bit	Field	Type	Reset	Description
7	GATE1	R/W	0	Timer 1 gate flag. When TR1 is set and GATE1= 1, timer and counter 1 only runs if the NINT1 pin is 1 (hardware control). When GATE1 = 0, timer and counter 1 only runs if TR1 = 1 (software control).
6	CNT1	R/W	0	Timer and counter-1 selector. If 0, input is from the internal system clock; if 1, input is from the T1 pin.
5	M1 (1)	R/W	0	Timer 1 mode-control bit M1.
4	M0 (1)	R/W	0	Timer 1 mode-control bit M0.
3	GATE0	R/W	0	Timer 0 gate flag. When TR0 is set and GATE0 = 1, timer and counter 0 only runs if NINT0 pin is 1 (hardware control). When GATE0 = 0, timer and counter 0 only runs if TR0 = 1 (software control).
2	CNT0	R/W	0	Timer and counter 0 selector. If 0, input is from the internal system clock; if 1, input is from the T0 pin.
1	M1 (0)	R/W	0	Timer 0 mode-control bit M1
0	M0 (0)	R/W	0	Timer 0 mode-control bit M0

Table 34. Timer Mode Control Bits

M1	M0	Operating Mode
0	0	13-bit timer and counter (M8048-compatible mode)
0	1	16-bit timer and counter
1	0	8-bit auto-reload timer and counter
1	1	Timer 0 is split into two halves. TL0 is an 8-bit timer and counter controlled by the standard timer 0 control bits. TH0 is an 8-bit timer and counter controlled by the standard timer 1 control bits. TH1 and TL1 are held (timer 1 is stopped).

7.6.1.7 Timer and Counter Data Registers (TL0, TL1, TH0, TH1)

Not bit-addressable.

TL0 and TH0 are the low and high bytes, respectively, of timer and counter 0. TL1 and TH1 are the low and high bytes, respectively, of timer and counter 1. In mode 2, the TL register is an 8-bit counter, and TH stores the reload value. On reset, all timer and counter registers are 00h.

The timer-clock resolution is 8 MHz.

7.6.1.7.1 TL0 Register (offset = 0x8A) [reset = 0]

Figure 57. TL0 Register

7	6	5	4	3	2	1	0
TL0[7]	TL0[6]	TL0[5]	TL0[4]	TL0[3]	TL0[2]	TL0[1]	TL0[0]
R/W-0	R/W-0	R/W-0	R/W-0	R/W-0	R/W-0	R/W-0	R/W-0

Table 35. TL0 Register Field Descriptions

Bit	Field	Type	Reset	Description
7-0	TL0[7:0]	R/W	0	

7.6.1.7.2 TL1 Register (offset = 0x8B) [reset = 0]

Figure 58. TL1 Register

7	6	5	4	3	2	1	0
TL1[7]	TL1[6]	TL1[5]	TL1[4]	TL1[3]	TL1[2]	TL1[1]	TL1[0]
R/W-0	R/W-0	R/W-0	R/W-0	R/W-0	R/W-0	R/W-0	R/W-0

Table 36. TL1 Register Field Descriptions

Bit	Field	Type	Reset	Description
7-0	TL1[7:0]	R/W	0	

7.6.1.7.3 TH0 Register (offset = 0x8C) [reset = 0]

Figure 59. TH0 Register

7	6	5	4	3	2	1	0
TH0[7]	TH0[6]	TH0[5]	TH0[4]	TH0[3]	TH0[2]	TH0[1]	TH0[0]
R/W-0	R/W-0	R/W-0	R/W-0	R/W-0	R/W-0	R/W-0	R/W-0

Table 37. TH0 Register Field Descriptions

Bit	Field	Type	Reset	Description
7-0	TH0[7:0]	R/W	0	

7.6.1.7.4 TH1 Register (offset = 0x8D) [reset = 0]
Figure 60. TH1 Register

7	6	5	4	3	2	1	0
TH1[7]	TH1[6]	TH1[5]	TH1[4]	TH1[3]	TH1[2]	TH1[1]	TH1[0]
R/W-0	R/W-0	R/W-0	R/W-0	R/W-0	R/W-0	R/W-0	R/W-0

Table 38. TH1 Register Field Descriptions

Bit	Field	Type	Reset	Description
7-0	TH1[7:0]	R/W	0	

7.6.1.8 UART Control Register (offset = 0x98) [reset = 0]

Bit-addressable

The UART uses two SFRs: SCON and SBUF. SCON is the control register and SBUF is the data register. Data is written to SBUF for transmission and SBUF is read to obtain received data. The received-data and transmitted-data registers are independent.

SM2 enables multi-processor communication over a single serial line and modifies the foregoing as listed in [Table 40](#). In modes 2 and 3, if SM2 is set then the receive interrupt is not generated if the received 9th data bit is 0. In mode 1, the receive interrupt is not generated unless a valid stop bit is received. In mode 0, SM2 should be 0.

Figure 61. UART Control (SCON) Register

7	6	5	4	3	2	1	0
SM0	SM1	SM2	REN	TB8	RB8	TI	RI
R/W-0	R/W-0	R/W-0	R/W-0	R/W-0	R/W-0	R/W-0	R/W-0

Table 39. SCON Register Field Descriptions

Bit	Field	Type	Reset	Description
7	SM0	R/W	0	UART mode specifier
6	SM1	R/W	0	UART mode specifier
5	SM2	R/W	0	UART mode specifier
4	REN	R/W	0	If 1, enables reception; if 0, disables reception
3	TB8	R/W	0	In modes 2 and 3, this is the 9th data bit sent.
2	RB8	R/W	0	In modes 2 and 3, this is the 9th data bit received. In mode 1, if SM2 = 0, this is the stop bit received. In mode 0, this bit is not used.
1	TI	R/W	0	Transmit interrupt flag. This is set by hardware at the end of the 8th bit in mode 0, or at the beginning of the stop bit in other modes. Must be cleared by software.
0	RI	R/W	0	Receive interrupt flag. This is set by hardware at the end of the 8th bit in mode 0, or at the half-point of the stop bit in other modes. Must be cleared by software.

Table 40. Mode Control Bit Operation⁽¹⁾

Mode	SM0	SM1	Operating Mode	Baud Rate
Mode 0	0	0	Mode 0: 8-bit shift register. $f_{\text{timer_clk}} / 2$	Baud rate = $f_{\text{timer_clk}} / 2$
Mode 1	0	1	Mode 1: 8 bit UART.	Baud rate = $(\text{SMOD}+1) \times f_{\text{timer_clk}} / (32 \times (256 - \text{TH1}))$
Mode 2	1	0	Mode 2: 9 bit UART.	Baud rate = $(\text{SMOD} + 1) \times f_{\text{timer_clk}} / 64$
Mode 3	1	1	Mode 3: 9 bit UART.	Baud rate = $(\text{SMOD} + 1) \times f_{\text{timer_clk}} / (32 \times (256 - \text{TH1}))$

(1) $f_{\text{timer_clk}}$ is the frequency of the TIMER_CLK input (8 MHz)

7.6.1.9 UART Data Register (offset = 0x99) [reset = 0]

Not bit-addressable

This register is used for both transmit and receive data. Transmit data is written to this location and receive data is read from this location, but the two paths are independent.

Figure 62. UART Data (SBUF) Register

7	6	5	4	3	2	1	0
SBUF[7]	SBUF[6]	SBUF[5]	SBUF[4]	SBUF[3]	SBUF[2]	SBUF[1]	SBUF[0]
R/W-0	R/W-0	R/W-0	R/W-0	R/W-0	R/W-0	R/W-0	R/W-0

Table 41. SBUF Register Field Descriptions

Bit	Field	Type	Reset	Description
7-0	SBUF[7:0]	R/W	0	

7.6.1.10 Interrupt Enable Register 0 (offset = 0xA8) [reset = 0]

Bit-addressable.

The two interrupt enable registers (IE0 and IE1) control the 14 available interrupts. Five of these interrupts are standard 8051-compatible legacy interrupts. The other nine are specific to the PGA450-Q1 device. More information on interrupts can be found in the [8051W Interrupts](#) section.

For each bit in this register, a 1 enables the corresponding interrupt, and a 0 disables it.

Figure 63. Interrupt Enable Register 0 (IE0)

7	6	5	4	3	2	1	0
EA	—	EI5	ES	ET1	EX1	ET0	EX0
R/W-0	R-0	R/W-0	R/W-0	R/W-0	R/W-0	R/W-0	R/W-0

Table 42. IE0 Register Field Descriptions

Bit	Field	Type	Reset	Description
7	EA	R/W	0	Enable or disable all interrupt bits.
6		R	0	
5	EI5	R/W	0	Enable external Interrupt 5, the LIN PID received interrupt.
4	ES	R/W	0	Enable serial port interrupt.
3	ET1	R/W	0	Enable timer 1 overflow interrupt.
2	EX1	R/W	0	Enable external interrupt 1, the NINT1 interrupt.
1	ET0	R/W	0	Enable timer 0 overflow interrupt.
0	EX0	R/W	0	Enable external interrupt 0, the NINT0 interrupt.

7.6.1.11 Interrupt Enable Register 1 (offset = 0xE8) [reset = 0]

Bit-addressable.

See the [8051W Interrupts](#) section for more information on available interrupts.

For each bit in this register, a 1 enables the corresponding interrupt, and a 0 disables it.

Figure 64. Interrupt Enable Register 1 (IE1)

7	6	5	4	3	2	1	0
EI13	EI12	EI11	EI10	EI9	EI8	EI7	EI6
R/W-0	R/W-0	R/W-0	R/W-0	R/W-0	R/W-0	R/W-0	R/W-0

Table 43. IE1 Register Field Descriptions

Bit	Field	Type	Reset	Description
7	EI13	R/W	0	Enable external interrupt 13.
6	EI12	R/W	0	Enable external interrupt 12.
5	EI11	R/W	0	Enable external interrupt 11.
4	EI10	R/W	0	Enable external interrupt 10.
3	EI9	R/W	0	Enable external interrupt 9.
2	EI8	R/W	0	Enable external interrupt 8, the LIN SYNC received interrupt.
1	EI7	R/W	0	Enable external interrupt 7, the LIN/SCI data transmit complete interrupt.
0	EI6	R/W	0	Enable external interrupt 6, the LIN/SCI data received interrupt.

7.6.1.12 Interrupt Priority Register 0 (offset = 0xB8) [reset = 0]

Bit-addressable.

For each bit in this register, a setting of 1 selects high priority for the corresponding interrupt, and a setting of 0 selects low priority. While an interrupt is being serviced, it may only be interrupted by a higher priority interrupt. See the [8051W Interrupts](#) section for more information on available interrupts.

Figure 65. Interrupt Priority Register 0 (IP0)

7	6	5	4	3	2	1	0
—		PI5	PS	PT1	PX1	PT0	PX0
R-0		R/W-0	R/W-0	R/W-0	R/W-0	R/W-0	R/W-0

Table 44. IP0 Register Field Descriptions

Bit	Field	Type	Reset	Description
7-6		R	0	
5	PI5	R/W	0	Select priority for external interrupt 5, the LIN PID received interrupt.
4	PS	R/W	0	Select priority for serial port interrupt.
3	PT1	R/W	0	Select priority for timer 1 overflow interrupt.
2	PX1	R/W	0	Select priority for external interrupt 1, the NINT1 interrupt.
1	PT0	R/W	0	Select priority for timer 0 overflow interrupt.
0	PX0	R/W	0	Select priority for external interrupt 0, the NINT0 interrupt.

7.6.1.13 Interrupt Priority Register 1 (offset = 0xF8) [reset = 0]

Bit-addressable

For each bit in this register, a setting of 1 selects high priority for the corresponding interrupt, and a setting 0 selects low priority. While an interrupt is being serviced, it may only be interrupted by a higher priority interrupt. See the [8051W Interrupts](#) section for more information on available interrupts.

Figure 66. Interrupt Priority Register 1 (IP1)

7	6	5	4	3	2	1	0
PI13	PI12	PI11	PI10	PI9	PI8	PI7	PI6
R/W-0	R/W-0	R/W-0	R/W-0	R/W-0	R/W-0	R/W-0	R/W-0

Table 45. IP1 Register Field Descriptions

Bit	Field	Type	Reset	Description
7	PI13	R/W	0	Select priority for external interrupt 13.
6	PI12	R/W	0	Select priority for external interrupt 12.
5	PI11	R/W	0	Select priority for external interrupt 11.
4	PI10	R/W	0	Select priority for external interrupt 10.
3	PI9	R/W	0	Select priority for external interrupt 9.
2	PI8	R/W	0	Select priority for external interrupt 8, the LIN SYNC received interrupt.
1	PI7	R/W	0	Select priority for external interrupt 7, the LIN/SCI data transmit complete interrupt.
0	PI6	R/W	0	Select priority for external interrupt 6, the LIN/SCI data received interrupt.

7.6.1.14 Program Status Word Register (offset = 0xD0) [reset = 0]

Bit-addressable

This register contains status information resulting from CPU and ALU operation.

Figure 67. Program Status Word (PSW) Register

7	6	5	4	3	2	1	0
CY	AC	F0	RS1	RS0	OV	F1	P
R/W-0	R/W-0	R/W-0	R/W-0	R/W-0	R/W-0	R/W-0	R/W-0

Table 46. PSW Register Field Descriptions

Bit	Field	Type	Reset	Description
7	CY	R/W	0	ALU carry flag
6	AC	R/W	0	ALU auxiliary carry flag
5	F0	R/W	0	General-purpose user-definable flag
4	RS1	R/W	0	Register bank-select bit 1
3	RS0	R/W	0	Register bank-select bit 0
2	OV	R/W	0	ALU overflow flag
1	F1	R/W	0	User-definable flag
0	P	R/W	0	Parity flag. Set each instruction cycle to indicate odd or even parity in the accumulator.

Table 47. Register Bank-Select Bit Operation

RS1	RS0	Register Bank Select
0	0	RB0: registers from 0x00–0x07
0	1	RB1: Registers from 0x08–0x0F
1	0	RB2: Registers from 0x10–0x17
1	1	RB3: Registers from 0x18–0x1F

7.6.1.15 Accumulator Register (offset = 0xE0) [reset = 0]

Bit-addressable

 This register provides one of the operands for most ALU operations which is denoted as *A* in the instruction table.

Figure 68. Accumulator (ACC) Register

7	6	5	4	3	2	1	0
ACC[7]	ACC[6]	ACC[5]	ACC[4]	ACC[3]	ACC[2]	ACC[1]	ACC[0]
R/W-0	R/W-0	R/W-0	R/W-0	R/W-0	R/W-0	R/W-0	R/W-0

Table 48. ACC Register Field Descriptions

Bit	Field	Type	Reset	Description
7-0	ACC[7:0]	R/W	0	

7.6.1.16 B Register (offset = 0xF0) [reset = 0]

Bit-addressable

 This register provides the second operand for multiply or divide instructions which is denoted as *B* in the instruction table. Otherwise, the register may be used as a scratch pad register.

Figure 69. B Register

7	6	5	4	3	2	1	0
B[7]	B[6]	B[5]	B[4]	B[3]	B[2]	B[1]	B[0]
R/W-0	R/W-0	R/W-0	R/W-0	R/W-0	R/W-0	R/W-0	R/W-0

Table 49. B Register Field Descriptions

Bit	Field	Type	Reset	Description
7-0	B[7:0]	R/W	0	

7.6.2 ESFR Registers

7.6.2.1 Bandpass Filter Coefficient B1 (BPF_B1) Register

Not bit-addressable.

These registers store the B1 coefficient value for the 2nd order Butterworth bandpass IIR filter. The B1 coefficient helps set the bandwidth of the bandpass filter, which can be programmed from 4 kHz to 7kHz. The specific values to program into these registers for each bandwidth are listed in [Table 7](#).

7.6.2.1.1 Bandpass Filter B1 MSB Register (offset = 0x92) [reset = 0]

Figure 70. Bandpass Filter B1 MSB (BPF_B1_MSB) Register

7	6	5	4	3	2	1	0
BPF_B1[15]	BPF_B1[14]	BPF_B1[13]	BPF_B1[12]	BPF_B1[11]	BPF_B1[10]	BPF_B1[9]	BPF_B1[8]
R/W-0	R/W-0	R/W-0	R/W-0	R/W-0	R/W-0	R/W-0	R/W-0

Table 50. BPF_B1_MSB Register Field Descriptions

Bit	Field	Type	Reset	Description
7-0	BPF_B1[15:8]	R/W	0	

7.6.2.1.2 Bandpass Filter B1 LSB Register (offset = 0x93) [reset = 0]

Figure 71. Bandpass Filter B1 LSB (BPF_B1_LSB) Register

7	6	5	4	3	2	1	0
BPF_B1[7]	BPF_B1[6]	BPF_B1[5]	BPF_B1[4]	BPF_B1[3]	BPF_B1[2]	BPF_B1[1]	BPF_B1[0]
R/W-0	R/W-0	R/W-0	R/W-0	R/W-0	R/W-0	R/W-0	R/W-0

Table 51. BPF_B1_LSB Register Field Descriptions

Bit	Field	Type	Reset	Description
7-0	BPF_B1[7:0]	R/W	0	

7.6.2.2 Bandpass Filter Coefficient A2 (BPF_A2) Registers

Not bit-addressable

These registers store the A2 coefficient value for the 2nd order Butterworth bandpass IIR filter. The A2 coefficient helps set the center frequency of the bandpass filter, which can be programmed from 40 kHz to 70 kHz. The specific values to program into these registers for each center frequency are listed in [Table 8](#).

7.6.2.2.1 Bandpass Filter Coefficient A2 MSB Register (offset = 0x94) [reset = 0]

Figure 72. Bandpass Filter Coefficient A2 MSB (BPF_A2_MSB) Register

7	6	5	4	3	2	1	0
BPF_A2[15]	BPF_A2[14]	BPF_A2[13]	BPF_A2[12]	BPF_A2[11]	BPF_A2[10]	BPF_A2[9]	BPF_A2[8]
R/W-0	R/W-0	R/W-0	R/W-0	R/W-0	R/W-0	R/W-0	R/W-0

Table 52. BPF_A2_MSB Register Field Descriptions

Bit	Field	Type	Reset	Description
7-0	BPF_A2[15:8]	R/W	0	

7.6.2.2.2 Bandpass Filter Coefficient A2 LSB Register (offset = 0x95) [reset = 0]
Figure 73. Bandpass Filter Coefficient A2 LSB (BPF_A2_LSB) Register

7	6	5	4	3	2	1	0
BPF_A2[7]	BPF_A2[6]	BPF_A2[5]	BPF_A2[4]	BPF_A2[3]	BPF_A2[2]	BPF_A2[1]	BPF_A2[0]
R/W-0	R/W-0	R/W-0	R/W-0	R/W-0	R/W-0	R/W-0	R/W-0

Table 53. BPF_A2_LSB Register Field Descriptions

Bit	Field	Type	Reset	Description
7-0	BPF_A2[7:0]	R/W	0	

7.6.2.3 Band-Pass Filter Coefficient A3 (BPF_A3) Register

Not bit-addressable

These registers store the A3 coefficient value for the 2nd order Butterworth bandpass IIR filter. The A3 coefficient helps set the bandwidth of the bandpass filter, which can be programmed from 4 kHz to 7kHz. The specific values to program into these registers for each bandwidth are listed in [Table 7](#).

7.6.2.3.1 Band-Pass Filter Coefficient A3 MSB Register (offset = 0x96) [reset = 0]
Figure 74. Band-Pass Filter Coefficient A3 MSB (BPF_A3_MSB) Register

7	6	5	4	3	2	1	0
BPF_A3[15]	BPF_A3[14]	BPF_A3[13]	BPF_A3[12]	BPF_A3[11]	BPF_A3[10]	BPF_A3[9]	BPF_A3[8]
R/W-0	R/W-0	R/W-0	R/W-0	R/W-0	R/W-0	R/W-0	R/W-0

Table 54. BPF_A3_MSB Register Field Descriptions

Bit	Field	Type	Reset	Description
7-0	BPF_A3[15:8]	R/W	0	

7.6.2.3.2 Band-Pass Filter Coefficient A3 LSB Register (offset = 0x97) [reset = 0]
Figure 75. Band-Pass Filter Coefficient A3 LSB (BPF_A3_LSB) Register

7	6	5	4	3	2	1	0
BPF_A3[7]	BPF_A3[6]	BPF_A3[5]	BPF_A3[4]	BPF_A3[3]	BPF_A3[2]	BPF_A3[1]	BPF_A3[0]
R/W-0	R/W-0	R/W-0	R/W-0	R/W-0	R/W-0	R/W-0	R/W-0

Table 55. BPF_A3_LSB Register Field Descriptions

Bit	Field	Type	Reset	Description
7-0	BPF_A3[7:0]	R/W	0	

7.6.2.4 Low-Pass Filter Coefficient B1 (LPF_B1) Registers

Not bit-addressable

These registers store the B1 coefficient value for the 1st order Butterworth low-pass IIR filter. The low-pass filter can be programmed with a cut-off frequency from 0.5 to 4 kHz. The specific values to program into these registers for each cut-off frequency are listed in [Table 9](#).

7.6.2.4.1 Low-Pass Filter Coefficient B1 MSB Register (offset = 0xA1) [reset = 0]

Figure 76. Low-Pass Filter Coefficient B1 MSB (LPF_B1_MSB) Register

7	6	5	4	3	2	1	0
—	LPF_B1[14]	LPF_B1[13]	LPF_B1[12]	LPF_B1[11]	LPF_B1[10]	LPF_B1[9]	LPF_B1[8]
R/W-0	R/W-0	R/W-0	R/W-0	R/W-0	R/W-0	R/W-0	R/W-0

Table 56. LPF_B1_MSB Register Field Descriptions

Bit	Field	Type	Reset	Description
7		R/W	0	
6-0	LPF_B1[14:8]	R/W	0	

7.6.2.4.2 Low-Pass Filter Coefficient B1 LSB Register (offset = 0xA2) [reset = 0]

Figure 77. Low-Pass Filter Coefficient B1 LSB (LPF_B1_LSB) Register

7	6	5	4	3	2	1	0
LPF_B1[7]	LPF_B1[6]	LPF_B1[5]	LPF_B1[4]	LPF_B1[3]	LPF_B1[2]	LPF_B1[1]	LPF_B1[0]
R/W-0	R/W-0	R/W-0	R/W-0	R/W-0	R/W-0	R/W-0	R/W-0

Table 57. LPF_B1_LSB Register Field Descriptions

Bit	Field	Type	Reset	Description
7-0	LPF_B1[7:0]	R/W	0	

7.6.2.5 Low-Pass Filter Coefficient A2 (LPF_A2) Registers

Not bit-addressable

These registers store the A2 coefficient value for the 1st order Butterworth low-pass IIR filter. The low-pass filter can be programmed with a cut-off frequency from 0.5 to 4 kHz. The specific values to program into these registers for each cut-off frequency are listed in [Table 9](#).

7.6.2.5.1 Low-Pass Filter Coefficient A2 MSB Register (offset = 0xA3) [reset = 0]

Figure 78. Low-Pass Filter Coefficient A2 MSB (LPF_A2_MSB) Register

7	6	5	4	3	2	1	0
—	LPF_A2[14]	LPF_A2[13]	LPF_A2[12]	LPF_A2[11]	LPF_A2[10]	LPF_A2[9]	LPF_A2[8]
R/W-0	R/W-0	R/W-0	R/W-0	R/W-0	R/W-0	R/W-0	R/W-0

Table 58. LPF_A2_MSB Register Field Descriptions

Bit	Field	Type	Reset	Description
7		R/W	0	
6-0	LPF_A2[14:8]	R/W	0	

7.6.2.5.2 Low-Pass Filter Coefficient A2 LSB Register (offset = 0xA4) [reset = 0]

Figure 79. Low-Pass Filter Coefficient A2 LSB (LPF_A2_LSB) Register

7	6	5	4	3	2	1	0
LPF_A2[7]	LPF_A2[6]	LPF_A2[5]	LPF_A2[4]	LPF_A2[3]	LPF_A2[2]	LPF_A2[1]	LPF_A2[0]
R/W-0	R/W-0	R/W-0	R/W-0	R/W-0	R/W-0	R/W-0	R/W-0

Table 59. LPF_A2_LSB Register Field Descriptions

Bit	Field	Type	Reset	Description
7-0	LPF_A2[7:0]	R/W	0	

7.6.2.6 Downsample Register (offset = 0xA5) [reset = 0]

Not bit-addressable.

This register sets the downsample rate in the datapath. If the low-pass filter is needed, then the downsampling rate must be set between 25 and 50. If the low-pass filter is not needed, then the DOWNSAMPLE register must be set between 1 and 63.

Figure 80. Downsample (DOWNSAMPLE) Register

7	6	5	4	3	2	1	0
–		DS5	DS4	DS3	DS2	DS1	DS0
R/W-0		R/W-0	R/W-0	R/W-0	R/W-0	R/W-0	R/W-0

Table 60. DOWNSAMPLE Register Field Descriptions

Bit	Field	Type	Reset	Description
7-6		R/W	0	
5	DS5	R/W	0	
4	DS4	R/W	0	
3	DS3	R/W	0	
2	DS2	R/W	0	
1	DS1	R/W	0	
0	DS0	R/W	0	

7.6.2.7 BURST ON A Duration (ON_A) Registers

Not bit-addressable

The ON_A register sets the duration that OUTA is held high during one burst. To generate a square wave of a particular frequency (f_{burst}):

$$ON_A = \text{dec2hex}(F_{OSC} / f_{burst} / 2) \quad (5)$$

The resolution is 62.5 ns.

7.6.2.7.1 BURST ON A Duration MSB Register (offset = 0xA6) [reset = 0]

Figure 81. BURST ON A Duration MSB (ONA_MSB) Register

7	6	5	4	3	2	1	0
–					ONA[10]	ONA[9]	ONA[8]
R/W-0					R/W-0	R/W-0	R/W-0

Table 61. ONA_MSB Register Field Descriptions

Bit	Field	Type	Reset	Description
7-3		R/W	0	
2-0	ONA[10:8]	R/W	0	

7.6.2.7.2 BURST ON A Duration LSB Register (offset = 0xA7) [reset = 0]
Figure 82. BURST ON A Duration LSB (ONA_LSB) Register

7	6	5	4	3	2	1	0
ONA[7]	ONA[6]	ONA[5]	ONA[4]	ONA[3]	ONA[2]	ONA[1]	ONA[0]
R/W-0	R/W-0	R/W-0	R/W-0	R/W-0	R/W-0	R/W-0	R/W-0

Table 62. ONA_LSB Register Field Descriptions

Bit	Field	Type	Reset	Description
7-0	ONA[7:0]	R/W	0	

7.6.2.8 BURST OFFA Duration (OFF_A) Register

Not bit-addressable

The OFF_A register sets the duration that OUTA is held low during one bust. To generate a square wave of a particular frequency, set OFF_A = ON_A. The resolution is 62.5 ns.

7.6.2.8.1 BURST OFFA Duration MSB Register (offset = 0xA9) [reset = 0]
Figure 83. BURST OFFA Duration MSB (OFFA_MSB) Register

7	6	5	4	3	2	1	0
—					OFFA[10]	OFFA[9]	OFFA[8]
R/W-0					R/W-0	R/W-0	R/W-0

Table 63. OFFA_MSB Register Field Descriptions

Bit	Field	Type	Reset	Description
7-3		R/W	0	
2-0	OFFA[10:8]	R/W	0	

7.6.2.8.2 BURST OFFA Duration LSB Register (offset = 0xAA) [reset = 0]
Figure 84. BURST OFFA Duration LSB (OFFA_LSB) Register

7	6	5	4	3	2	1	0
OFFA[7]	OFFA[6]	OFFA[5]	OFFA[4]	OFFA[3]	OFFA[2]	OFFA[1]	OFFA[0]
R/W-0	R/W-0	R/W-0	R/W-0	R/W-0	R/W-0	R/W-0	R/W-0

Table 64. OFFA_LSB Register Field Descriptions

Bit	Field	Type	Reset	Description
7-0	OFFA[7:0]	R/W	0	

7.6.2.9 BURST ON B Duration (ON_B) Registers

Not bit-addressable

The ON_B register sets the duration that OUTB is held high during one burst. To generate a square wave of a particular frequency (f_{burst}):

$$ON_B = \text{dec2hex}(F_{OSC} / f_{burst} / 2) \quad (6)$$

The resolution is 62.5 ns.

7.6.2.9.1 BURST ON B Duration MSB Register (offset = 0xAB) [reset = 0]

Figure 85. BURST ON B Duration MSB (ONB_MSB) Register

7	6	5	4	3	2	1	0
—					ONB[10]	ONB[9]	ONB[8]
R/W-0					R/W-0	R/W-0	R/W-0

Table 65. ONB_MSB Register Field Descriptions

Bit	Field	Type	Reset	Description
7-3		R/W	0	
2-0	ONB[10:8]	R/W	0	

7.6.2.9.2 BURST ON B Duration LSB Register (offset = 0xAC) [reset = 0]

Figure 86. BURST ON B Duration LSB (ONB_LSB) Register

7	6	5	4	3	2	1	0
ONB[7]	ONB[6]	ONB[5]	ONB[4]	ONB[3]	ONB[2]	ONB[1]	ONB[0]
R/W-0	R/W-0	R/W-0	R/W-0	R/W-0	R/W-0	R/W-0	R/W-0

Table 66. ONB_LSB Register Field Descriptions

Bit	Field	Type	Reset	Description
7-0	ONB[7:0]	R/W	0	

7.6.2.10 BURST OFF B Duration (OFF_B) Register

Not bit-addressable

The OFF_B register sets the duration that OUTB is held low during one burst. To generate a square wave of a particular frequency, set OFF_B = ON_B. The resolution is 62.5 ns.

7.6.2.10.1 BURST OFF B Duration MSB Register (offset = 0xAD) [reset = 0]

Figure 87. BURST OFF B Duration MSB (OFFB_MSB) Register

7	6	5	4	3	2	1	0
—					OFFB[10]	OFFB[9]	OFFB[8]
R/W-0					R/W-0	R/W-0	R/W-0

Table 67. OFFB_MSB Register Field Descriptions

Bit	Field	Type	Reset	Description
7-3		R/W	0	
2-0	OFFB[10:8]	R/W	0	

7.6.2.10.2 BURST OFF B Duration LSB Register (offset = 0xAE) [reset = 0]
Figure 88. BURST OFF B Duration LSB (OFFB_LSB) Register

7	6	5	4	3	2	1	0
OFFB[7]	OFFB[6]	OFFB[5]	OFFB[4]	OFFB[3]	OFFB[2]	OFFB[1]	OFFB[0]
R/W-0	R/W-0	R/W-0	R/W-0	R/W-0	R/W-0	R/W-0	R/W-0

Table 68. OFFB_LSB Register Field Descriptions

Bit	Field	Type	Reset	Description
7-0	OFFB[7:0]	R/W	0	

7.6.2.11 Pulse Count A Register (offset = 0xAF) [reset = 0]

Not bit-addressable

The PULSE_CNTA register sets the number of pulses that occur on OUTA when a burst is initiated. The number of pulses can be set from 0 to 63.

Figure 89. Pulse Count A (PULSE_CNTA) Register

7	6	5	4	3	2	1	0
—	PC5	PCA4	PCA3	PCA2	PCA1	PCA0	
R/W-0	R/W-0	R/W-0	R/W-0	R/W-0	R/W-0	R/W-0	R/W-0

Table 69. PULSE_CNTA Register Field Descriptions

Bit	Field	Type	Reset	Description
7-6		R/W	0	
5	PC5	R/W	0	
4	PCA4	R/W	0	
3	PCA3	R/W	0	
2	PCA2	R/W	0	
1	PCA1	R/W	0	
0	PCA0	R/W	0	

7.6.2.12 Pulse Count B Register (offset = 0xB1) [reset = 0]

Not bit-addressable

The PULSE_CNTB register sets the number of pulses that occur on OUTB when a burst is initiated. The number of pulses can be set from 0 to 63.

Figure 90. Pulse Count B (PULSE_CNTB) Register

7	6	5	4	3	2	1	0
—		PCB5	PCB4	PCB3	PCB2	PCB1	PCB0
R/W-0		R/W-0	R/W-0	R/W-0	R/W-0	R/W-0	R/W-0

Table 70. PULSE_CNTB Register Field Descriptions

Bit	Field	Type	Reset	Description
7-6		R/W	0	
5	PCB5	R/W	0	
4	PCB4	R/W	0	
3	PCB3	R/W	0	
2	PCB2	R/W	0	
1	PCB1	R/W	0	
0	PCB0	R/W	0	

7.6.2.13 Deadtime Register (offset = 0xB2) [reset = 0]

Not bit-addressable

The deadtime is the time both OUTA and OUTB are held low before one or the other turns on. This time is shaved off of the end of the time set in the ON_A and ON_B registers.

$$\text{DEADTIME} = F_{\text{OSC}} \times t_{\text{deadtime}} \quad (7)$$

The resolution is 62.5 ns .

Figure 91. Deadtime (DEADTIME) Register

7	6	5	4	3	2	1	0
DT7	DT6	DT5	DT4	DT3	DT2	DT1	DT0
R/W-0	R/W-0	R/W-0	R/W-0	R/W-0	R/W-0	R/W-0	R/W-0

Table 71. DEADTIME Register Field Descriptions

Bit	Field	Type	Reset	Description
7	DT7	R/W	0	
6	DT6	R/W	0	
5	DT5	R/W	0	
4	DT4	R/W	0	
3	DT3	R/W	0	
2	DT2	R/W	0	
1	DT1	R/W	0	
0	DT0	R/W	0	

7.6.2.14 Burst Mode Register (offset = 0xB3) [reset = 0]

Not bit-addressable

The BURST_MODE register selects from five possible burst configurations. See [Table 4](#) for additional detail.

Figure 92. Burst Mode (BURST_MODE) Register

7	6	5	4	3	2	1	0
—					BMODE2	BMODE1	BMODE0
R/W-0					R/W-0	R/W-0	R/W-0

Table 72. BURST_MODE Register Field Descriptions

Bit	Field	Type	Reset	Description
7-3		R/W	0	
2	BMODE2	R/W	0	See Table 73 .
1	BMODE1	R/W	0	See Table 73 .
0	BMODE0	R/W	0	See Table 73 .

Table 73. Burst Mode Bit Configurations

BMODE2	BMODE1	BMODE0	BURST MODE DESCRIPTION
0	0	0	Push-pull mode
0	0	1	Single-ended on OUTA, micro control on OUTB
0	1	0	Single-ended on OUTB, micro control on OUTA
0	1	1	Single-ended on OUTA, single-ended on OUTB
1	0	0	Micro on OUTA, micro on OUTB
1	0	1	For TI use only
1	1	0	Illegal
1	1	1	Illegal

7.6.2.15 Temperature Sensor Register (offset = 0xB4) [reset = 0]

Not bit-addressable

Figure 93. Temperature Sensor (TEMP_SENS) Register

7	6	5	4	3	2	1	0
TS7	TS6	TS5	TS4	TS3	TS2	TS1	TS0
R-0	R-0	R-0	R-0	R-0	R-0	R-0	R-0

Table 74. TEMP_SENS Register Field Descriptions

Bit	Field	Type	Reset	Description
7	TS7	R	0	
6	TS6	R	0	
5	TS5	R	0	
4	TS4	R	0	
3	TS3	R	0	
2	TS2	R	0	
1	TS1	R	0	
0	TS0	R	0	

7.6.2.16 Saturation Deglitch Time Register (offset = 0xB5) [reset = 0]

Not bit-addressable

The saturation deglitch timer begins when the voltage envelope at the LIM pin drops below a value set in the SAT_CTRL register. When the deglitch timer is finished, the SAT_DONE bit in the STATUS2 register is set to 1, then the time because SAT_EN was set to 1 is captured into the SAT_TIME register. Further details about this process can be found in the [Transducer Saturation Time](#) section.

$$\text{SAT_DEGLITCH} = t_{\text{deglitch}} / 2 \mu\text{s} \quad (8)$$

Figure 94. Saturation Deglitch Time (SAT_DEGLITCH) Register

7	6	5	4	3	2	1	0
SD7	SD6	SD5	SD4	SD3	SD2	SD1	SD0
R/W-0	R/W-0	R/W-0	R/W-0	R/W-0	R/W-0	R/W-0	R/W-0

Table 75. SAT_DEGLITCH Register Field Descriptions

Bit	Field	Type	Reset	Description
7	SD7	R/W	0	
6	SD6	R/W	0	
5	SD5	R/W	0	
4	SD4	R/W	0	
3	SD3	R/W	0	
2	SD2	R/W	0	
1	SD1	R/W	0	
0	SD0	R/W	0	

7.6.2.17 Saturation Time Capture Register (offset = 0xB6) [reset = 0]

Not bit-addressable

The saturation timer starts when SAT_EN is set to 1 (coincident with the start of a burst). The value of the timer is captured into the SAT_TIME register when the saturation deglitch timer reaches its programmed value (set in the SAT_DEGLITCH register). The saturation deglitch timer does not begin until after the voltage envelope at the LIM pin drops below the value programmed by the SAT_CTRL register.

$$t_{\text{sat}} = \text{SAT_TIME} \times 16 \mu\text{s} \quad (9)$$

Figure 95. Saturation Time Capture (SAT_TIME) Register

7	6	5	4	3	2	1	0
ST7	ST6	ST5	ST4	ST3	ST2	ST1	ST0
R-0	R-0	R-0	R-0	R-0	R-0	R-0	R-0

Table 76. SAT_TIME Register Field Descriptions

Bit	Field	Type	Reset	Description
7	ST7	R	0	
6	ST6	R	0	
5	ST5	R	0	
4	ST4	R	0	
3	ST3	R	0	
2	ST2	R	0	
1	ST1	R	0	
0	ST0	R	0	

7.6.2.18 Control 1 Register (offset = 0xB7) [reset = 0]

Not bit-addressable

The SAT_SEL0 and SAT_SEL1 bits set the threshold level for the voltage envelope at the LIM pin. When the envelope at the LIM pin drops below the threshold, the saturation deglitch timer starts.

The LNA_GAIN0 and LNA_GAIN1 bits configure the gain of the LNA as shown in [Table 78](#).

LS_FAULT_LOGIC_EN enables the low-side FET diagnostics. A fault is detected if both the V_{GS} and V_{DS} voltages on the LS FET remain above 2.5 V for either 1 μ s or 2 μ s (selectable through the LS_FAULT_TIMER_SEL bit). See the [Diagnostics](#) section for additional information.

Figure 96. Control 1 (CONTROL_1) Register

7	6	5	4	3	2	1	0
—		LS_FAULT_LO GIC_EN	LS_FAULT_TI MER_SEL	LNA_GAIN1	LNA_GAIN0	SAT_SEL1	SAT_SEL0
R/W-0		R/W-0	R/W-0	R/W-0	R/W-0	R/W-0	R/W-0

Table 77. CONTROL_1 Register Field Descriptions

Bit	Field	Type	Reset	Description
7-6		R/W	0	
5	LS_FAULT_LOGIC_EN	R/W	0	0: Low-side fault-monitoring deglitch time is 2 μ s. 1: Low-side fault-monitoring deglitch time is 1 μ s
4	LS_FAULT_TIMER_SEL	R/W	0	0: Low-side fault monitoring is disabled. 1: Low-side fault monitoring is enabled.
3	LNA_GAIN1	R/W	0	See Table 79 .
2	LNA_GAIN0	R/W	0	See Table 79 .
1	SAT_SEL1	R/W	0	See Table 78 .
0	SAT_SEL0	R/W	0	See Table 78 .

Table 78. SAT_SELx Bit Configuration

Bit	SAT_SEL1	SAT_SEL0	Nominal Saturation Threshold
SAT_SEL0	0	0	200 mV
	0	1	300 mV
SAT_SEL1	1	0	400 mV
	1	1	600 mV

Table 79. LNA_GAINx Bit Configuration

Bit	LNA_GAIN1	LNA_GAIN0	Nominal Gain Value
BIT2: LNA_GAIN0	0	0	1750 V/V (63.52 dB)
	0	1	930 V/V (59.08 dB)
BIT3: LNA_GAIN1	1	0	517V/V (53.98 dB)
	1	1	104 V/V (40.00 dB)

7.6.2.19 Blanking Timer Register (offset = 0xB9) [reset = 0]

Not bit-addressable

The blanking time is how long after echo processing is enabled before the FIFO starts filling up. Echo processing is enabled when ECHO_EN = 1, which is when the blanking timer starts. Typically this is set concurrently with the start of a burst. See the [Datapath Activation and Blanking Timer](#) section for additional information.

$$\text{BLANKING_TIMER} = t_{\text{blanking}} / 16 \mu\text{s} \quad (10)$$

Figure 97. Blanking Timer (BLANKING_TIMER) Register

7	6	5	4	3	2	1	0
BT7	BT6	BT5	BT4	BT3	BT2	BT1	BT0
R/W-0	R/W-0	R/W-0	R/W-0	R/W-0	R/W-0	R/W-0	R/W-0

Table 80. BLANKING_TIMER Register Field Descriptions

Bit	Field	Type	Reset	Description
7	BT7	R/W	0	
6	BT6	R/W	0	
5	BT5	R/W	0	
4	BT4	R/W	0	
3	BT3	R/W	0	
2	BT2	R/W	0	
1	BT1	R/W	0	
0	BT0	R/W	0	

7.6.2.20 Free Running Timer (FRT) Registers

Not bit-addressable

The FRT register is a shadow of the free running timer. The current value of the free running timer is copied into the FRT register when a 1 is written to the CAP_FR_TMR bit in the EN_CTRL register. The resolution of the register is 1 μs. See the [Free-Running Timer](#) section for additional information.

7.6.2.20.1 Free Running Timer MSB Registers (offset = 0xBA) [reset = 0]

Figure 98. Free Running Timer MSB (FRT_MSB) Registers

7	6	5	4	3	2	1	0
FRT[15]	FRT[14]	FRT[13]	FRT[12]	FRT[11]	FRT[10]	FRT[9]	FRT[8]
R-0	R-0	R-0	R-0	R-0	R-0	R-0	R-0

Table 81. FRT_MSB Register Field Descriptions

Bit	Field	Type	Reset	Description
7-0	FRT[15:8]	R	0	

7.6.2.20.2 Free Running Timer LSB Registers (offset = 0xBB) [reset = 0]

Figure 99. Free Running Timer LSB (FRT_LSB) Registers

7	6	5	4	3	2	1	0
FRT[7]	FRT[6]	FRT[5]	FRT[4]	FRT[3]	FRT[2]	FRT[1]	FRT[0]
R-0	R-0	R-0	R-0	R-0	R-0	R-0	R-0

Table 82. FRT_LSB Register Field Descriptions

Bit	Field	Type	Reset	Description
7-0	FRT[7:0]	R	0	

7.6.2.21 GPIO Control Register (offset = 0xBC) [reset = 0]

Not bit-addressable

The two GPIOs and TX pin can be configured in strong or weak pullup mode. The MICRO_LIN_TX bit controls the MUX that determines whether the LIN TX signal is controlled by P2.3 in the 8051W or the embedded LIN slave or buffered SCI protocol. See [Figure 39](#).

Figure 100. GPIO Control (GPIO_CTRL) Register

7	6	5	4	3	2	1	0
MICRO_LIN_TX	UARTTX_CONFIG	GPIO2_CONFIG2	GPIO2_CONFIG1	GPIO2_CONFIG0	GPIO1_CONFIG2	GPIO1_CONFIG1	GPIO1_CONFIG0
R/W-0	R/W-0	R/W-0	R/W-0	R/W-0	R/W-0	R/W-0	R/W-0

Table 83. GPIO_CTRL Register Field Descriptions

Bit	Field	Type	Reset	Description
7	MICRO_LIN_TX	R/W	0	0: 8051W port I/O drives TX pin in weak pullup mode 1: 8051W port I/O drives TX pin in strong pullup mode
6	UARTTX_CONFIG	R/W	0	0: LIN/SCI peripheral drives LIN transceiver 1: 8051W port I/O drives LIN transceiver
5	GPIO2_CONFIG2	R/W	0	See Table 84 .
4	GPIO2_CONFIG1	R/W	0	See Table 84 .
3	GPIO2_CONFIG0	R/W	0	See Table 84 .
2	GPIO1_CONFIG2	R/W	0	See Table 85 .
1	GPIO1_CONFIG1	R/W	0	See Table 85 .
0	GPIO1_CONFIG0	R/W	0	See Table 85 .

Table 84. GPIO2_CONFIGx Bit Configuration

Bit	GPIO2_CONFIG2	GPIO2_CONFIG1	GPIO2_CONFIG0	GPIO2 Mode
GPIO2_CONFIG0	0	X	X	8051W port I/O drives GPIO2 pin in weak pullup mode
GPIO2_CONFIG1 GPIO2_CONFIG2	1	1	X	8051W port I/O drives GPIO2 in strong pullup mode

Table 85. GPIO1_CONFIGx Bit Configuration

Bit	GPIO1_CONFIG2	GPIO1_CONFIG1	GPIO1_CONFIG0	GPIO1 Mode
GPIO1_CONFIG0	0	X	X	8051W port I/O drives GPIO1 pin in weak pullup mode
GPIO1_CONFIG1	1	1	X	8051W port I/O Drives GPIO1 in strong pullup mode
GPIO1_CONFIG2	1	0	1	Reserved, do not use

7.6.2.22 Clock Select Register (offset = 0xBD) [reset = 0]

Not bit-addressable

This register controls the MUX that determines the source of the system clock. See the [Clock](#) section for additional information.

Figure 101. Clock Select (CLK_SEL) Register

7	6	5	4	3	2	1	0
—						CLK_SEL1	CLK_SEL0
R/W-0						R/W-0	R/W-0

Table 86. CLK_SEL Register Field Descriptions

Bit	Field	Type	Reset	Description
7-2		R/W	0	
1	CLK_SEL1	R/W	0	See Table 87 .
0	CLK_SEL0	R/W	0	See Table 87 .

Table 87. CLK_SELx Bit Configurations

CLK_SEL1	CLK_SEL0	CLOCK MODE
0	0	Internal clock. Ignore synchronization pulse received on the LIN bus
0	1	Internal clock. Process synchronization pulse received on the LIN bus
1	0	External crystal clock
1	1	Internal clock. Ignore synchronization pulse received on the LIN bus.

7.6.2.23 Watchdog Enable Register (offset = 0xBE) [reset = 0]

Not bit-addressable

The oscillator watchdog resets the 8051W core if the main oscillator or external crystal oscillator falls outside the valid range. The software watchdog must be serviced by software every 250ms or it will reset the 8051W core. Both of these watchdogs can be enabled or disabled with this register. See the [Main Oscillator Watchdog](#) section for additional information on both of these watchdogs.

Figure 102. Watchdog Enable (WD_EN) Register

7	6	5	4	3	2	1	0
—						SW_WD_EN	OSC_WD_EN
R/W-0						R/W-0	R/W-0

Table 88. WD_EN Register Field Descriptions

Bit	Field	Type	Reset	Description
7-2		R/W	0	
1	SW_WD_EN	R/W	0	0: Disable software watchdog. 1: Enable software watchdog.
0	OSC_WD_EN	R/W	0	0: Disable oscillator watchdog. 1: Enable oscillator watchdog.

7.6.2.24 LIN/SCI Select Register (offset = 0xBF) [reset = 0]

Not bit-addressable

The LIN_SCI bit selects between using the embedded LIN2.1 slave protocol or SCI buffered mode. SCI buffered mode can transmit or receive 8 bytes of data, beyond that the communication protocol is determined by what is programmed in the 8051W software. See the [LIN 2.1 Slave and Buffered SCI](#) section for additional information.

Figure 103. LIN/SCI Select (LIN_SCI) Register

7	6	5	4	3	2	1	0
—							LIN_SCI
R/W-0							R/W-0

Table 89. LIN_SCI Register Field Descriptions

Bit	Field	Type	Reset	Description
7-1		R/W	0	
0	LIN_SCI	R/W	0	0: LIN bus operates with LIN protocol. 1: LIN bus operates in SCI mode.

7.6.2.25 EEPROM Control Register (offset = 0xC0) [reset = 0]

Bit-addressable

The RELOAD bit in this register copies the contents of the EEPROM into the EEPROM cache. The WRITE bit programs the EEPROM with the values stored in the EEPROM cache. Programming starts when the WRITE bit is set to 1. The WRITE bit remains at 1 until the programming is completed, at which point it drops back to 0. See the [EEPROM Memory Organization](#) section for additional information.

Figure 104. EEPROM Control (EE_CTRL) Register

7	6	5	4	3	2	1	0
—					—	RELOAD	WRITE/EE_ST ATUS
R/W-0					R-0	W-0	R/W-0

Table 90. EE_CTRL Register Field Descriptions

Bit	Field	Type	Reset	Description
7-3		R/W	0	
2		R	0	
1	RELOAD	W	0	0: No action 1: Reload EEPROM contents to EEPROM buffer.
0	WRITE/EE_STATUS	R/W	0	Write: 0: No action 1: Program data in EEPROM buffer into EEPROM. Read: 0: EEPROM programming is idle. 1: EEPROM is being programmed.

7.6.2.26 Status 1 (STATUS1) Register (offset = 0xC1) [reset = 0]

Not bit-addressable

This register stores power-block diagnostic information as well as information about self-tests. For more information see the [Diagnostics](#) section and the [Internal ASIC TRIM Validity](#) for the trim test and the FIFO RAM test.

Figure 105. Status 1 (STATUS1) Register

7	6	5	4	3	2	1	0
–	TRIM_FAIL	MBIST_DONE	MBIST_FAIL	VPWR_OV	AVDD_UV	AVDD_OC	RBIAS_OC
R/W-0	R-0	R-0	R-0	R-0	R-0	R-0	R-0

Table 91. STATUS1 Register Field Descriptions

Bit	Field	Type	Reset	Description
7		R/W	0	
6	TRIM_FAIL	R	0	0: Internal ASIC trim values not corrupted 1: Internal ASIC trim values corrupted
5	MBIST_DONE	R	0	0: FIFO RAM built-in self-test complete 1: FIFO RAM built-in self-test did not complete.
4	MBIST_FAIL	R	0	0: FIFO RAM built-in self-test passed. 1: FIFO RAM built-in self-test did not pass or did not start.
3	VPWR_OV	R	0	0: No overvoltage on VPWR pin 1: Overvoltage on VPWR pin
2	AVDD_UV	R	0	0: No undervoltage on AVDD pin 1: AVDD pin voltage < 4.2 V nominal
1	AVDD_OC	R	0	0: No overcurrent on AVDD pin 1: AVDD pin current > 55 mA nominal
0	RBIAS_OC	R	0	0: No overcurrent on RBIAS pin 1: RBIAS pin current > 63 µA nominal

7.6.2.27 Status 2 Register (offset = 0xC2) [reset = 0]

Not bit-addressable

The VREG_RDY bit is set to 1 when the VREG pin is close to the programmed voltage. The VREG pin should be ready before starting a burst. After the burst is completed, the SAT_DONE bit indicates when the voltage envelope at the LIM pin has decreased to below the programmed saturation threshold. The time that this takes is stored in the SAT_TIME register.

The WD_TO_SW and WD_TO_OSC bits indicate the status of the software and oscillator watchdogs. Note that both watchdogs must be enabled in the WD_EN register to use.

The LSA_FLT and LSB_FLT bits are diagnostic flags for the low-side FET drivers which protect the FETs from sinking excessive currents. This diagnostic must be enabled in the LS_FAULT_LOGIC_EN bit in CONTROL_1 register before use.

Figure 106. Status 2 (STATUS2) Register

7	6	5	4	3	2	1	0
—		WD_TO_OSC	LSB_FAULT	LSA_FAULT	WD_TO_SW	SAT_DONE	VREG_READY
R/W-0		R-0	R-0	R-0	R-0	R-0	R-0

Table 92. STATUS2 Register Field Descriptions

Bit	Field	Type	Reset	Description
7-0		R/W	0	
5	WD_TO_OSC	R	0	0: Internal oscillator is normal. 1: Internal oscillator is abnormal.
4	LSB_FAULT	R	0	0: No Fault on LSB 1: Fault on LSB
3	LSA_FAULT	R	0	0: No fault on LSA 1: Fault on LSA
2	WD_TO_SW	R	0	0: Software watchdog has not timed out. 1: Software watchdog has timed out and the micro has been reset.
1	SAT_DONE	R	0	0: Echo signal is not below saturation threshold. 1: Echo signal is below saturation threshold.
0	VREG_READY	R	0	0: VREG is not in regulation. 1: VREG is less than 200 mV (nominal) below set point selected by VREG_SEL bits.

7.6.2.28 Power Mode Register (offset = 0xC3) [reset = 0]

Not bit-addressable

The ACTIVE_EN bit enables the support circuitry related to burst generation and echo processing. This bit must be set before enabling burst generation or echo processing (both enabled in the EN_CTRL register).

The VREG_EN bit enables a 100-mA current source to charge an external capacitor. This can then be used to drive the primary of a transformer. The VREG voltage can be controlled through the VREG_SEL register. See the [VREG](#) section for additional information.

Figure 107. Power Mode (PWR_MODE) Register

7	6	5	4	3	2	1	0
—						VREG_EN	ACTIVE_EN
R/W-0						R/W-1	R/W-0

Table 93. PWR_MODE Register Field Descriptions

Bit	Field	Type	Reset	Description
7-2		R/W	0	
1	VREG_EN	R/W	0	0: VREG is disabled. 1: VREG is enabled.
0	ACTIVE_EN	R/W	0	0: EEPROM, VPWR_MON, LNA, LS diagnostics, OUTA, OUTB, ADC are disabled. 1: All the foregoing are enabled.

7.6.2.29 Datapath and SCI Control Register (offset = 0xC4) [reset = 0]

Not bit-addressable

This register controls what is loaded into the FIFO RAM. By default, the FIFO is loaded with the digital datapath output, but the FIFO_ADC gives the option of bypassing the datapath altogether and loading the FIFO directly from the ADC. The FIFO_PEAKDET bit determines whether or not the low-pass filter is used in the digital datapath.

The SCI_TX_EN bit is used while transmitting through SCI. See the [SCI Buffered Mode](#) section for additional information on SCI communication procedures.

Figure 108. Datapath and SCI Control (DP_SCI_CTRL) Register

7	6	5	4	3	2	1	0	
—						FIFO_ADC	SCI_TX_EN	FIFO_PEAKDET
R/W-0						R/W-0	R/W-1	R/W-1

Table 94. DP_SCI_CTRL Register Field Descriptions

Bit	Field	Type	Reset	Description
7-3		R/W	0	
2	FIFO_ADC	R/W	0	0: FIFO is loaded with digital datapath output 1: FIFO is loaded with ADC output.
1	SCI_TX_EN	R/W	0	0: No action 1: SCI transmit enable
0	FIFO_PEAKDET	R/W	0	0: In the digital datapath, the lowpass filter is used. 1: In the digital datapath, the lowpass filter is bypassed and the peak-detector output is used (No low-pass filtering).

7.6.2.30 FIFO Control Register (offset = 0xC5) [reset =]

Not bit-addressable

The digital datapath has a resolution of 12 bits; however, to conserve space in the FIFO RAM, there are several options about how to store the data from the datapath into the FIFO. All 12 bits can be stored, which effectively halves the number of data points that can be stored in the FIFO. The other three options include the lower eight bits, the upper eight bits, and the middle eight bits. The lower and middle eight bit options also include a saturation check. If there is an overflow, then 0xFF is stored instead of what the lower or middle eight bits actually was.

If FIFO rollover mode is enabled, then the FIFO write pointer will roll over to 0 after all 768 bytes in the FIFO have been written to. After the write pointer rolls over, the FIFO RAM will continue to fill with samples from the digital datapath.

Figure 109. FIFO Control (FIFO_CTRL) Register

7	6	5	4	3	2	1	0
—					ROLLOVER	FMODE1	FMODE0
R/W-0					R/W-0	R/W-1	R/W-1

Table 95. FIFO_CTRL Register Field Descriptions

Bit	Field	Type	Reset	Description
7		R/W	0	
2	ROLLOVER	R/W	0	0: FIFO rolls at the end. 1: No rollover of the FIFO
1	FMODE1	R/W	0	See Table 96 .
0	FMODE0	R/W	0	See Table 96 .

Table 96. FMODEx Bit Configuration

FMODE1	FMODE0	DATAPATH BITS STORED INTO THE FIFO
0	0	datapath bits [11:0]
0	1	datapath bits [11:4]
1	0	datapath bits [7:0] with saturation check on datapath bits [11:8]
1	1	datapath bits [10:3] with saturation check on datapath bit [11]

7.6.2.31 Enable Control Register (offset = 0xC8) [reset = 0]

Bit Addressable

The EN_CTRL register is used to initiate a distance measurement. BURST_X_EN enables a burst on the low-side drivers, ECHO_EN starts to fill the FIFO with data from the digital datapath, SAT_EN triggers a saturation measurement for diagnostic purposes, and CAP_FR_TMR captures the free running timer to the free running timer shadow register. These can all be triggered at the same time or individually depending on the application.

Figure 110. Enable Control (EN_CTRL) Register

7	6	5	4	3	2	1	0
CAP_FR_TMR	—			ECHO_EN	SAT_EN	BURST_B_EN	BURST_A_EN
W-0	R/W-0			R/W-0	R/W-0	W-0	W-0

Table 97. EN_CTRL Register Field Descriptions

Bit	Field	Type	Reset	Description
7	CAP_FR_TMR	W	0	0: No action 1: Capture free-running timer value to ESFR FRT.
6-4		R/W	0	
3	ECHO_EN	R/W	0	0: Disable echo processing – the FIFO is not filled. 1: Enable echo processing – the FIFO starts filling after the blanking timer expires.
2	SAT_EN	R/W	0	0: Disable saturation monitor function. 1: Enable saturation monitor function.
1	BURST_B_EN	W	0	0: No Action 1: Enable burst on OUTB in single-ended
0	BURST_A_EN	W	0	0: No action 1: Enable burst on OUTA in single-ended and OUTA/OUTB in push-pull.

7.6.2.32 LIN/SCI Rx Data (RX_DATAx) Register (offset = 0xC9 to 0xD1) [reset = 0]

Not bit-addressable

Received data from LIN/SCI is stored in the RX_DATAx register. See the [LIN 2.1 Slave and Buffered SCI](#) section for more information about LIN/SCI communication.

Figure 111. LIN/SCI Rx Data (RX_DATAx) Register

7	6	5	4	3	2	1	0
RX_DATAx[7]	RX_DATAx[6]	RX_DATAx[5]	RX_DATAx[4]	RX_DATAx[3]	RX_DATAx[2]	RX_DATAx[1]	RX_DATAx[0]
R-0	R-0	R-0	R-0	R-0	R-0	R-0	R-0

Table 98. RX_DATAx Register Field Descriptions

Bit	Field	Type	Reset	Description
7-0	RX_DATAx[7:0]	R	0	

7.6.2.33 LIN PID Register (offset = 0xD2) [reset = 0]

Not bit-addressable

The LIN_PID register is used to store the received PID frame from the most recent LIN message. This can be interpreted by the PGA450-Q1 application firmware to determine how to respond to the message. See the [LIN 2.1 Slave and Buffered SCI](#) section for more information about LIN/SCI communication.

Figure 112. LIN PID (LIN_PID) Register

7	6	5	4	3	2	1	0
PID7	PID6	PID5	PID4	PID3	PID2	PID1	PID0
R-0	R-0	R-0	R-0	R-0	R-0	R-0	R-0

Table 99. LIN_PID Register Field Descriptions

Bit	Field	Type	Reset	Description
7	PID7	R	0	
6	PID6	R	0	
5	PID5	R	0	
4	PID4	R	0	
3	PID3	R	0	
2	PID2	R	0	
1	PID1	R	0	
0	PID0	R	0	

7.6.2.34 LIN/SCI Tx Data Registers (offset = 0xD3 to 0xDA) [reset = 0]

Not bit-addressable

Data to be transmitted over LIN/SCI from the PGA450-Q1 must be programmed to the TX_DATAx register before triggering a transmit message via the RX_TX bit in the LIN_CTRL register. The number of bytes transmitted is set by the DATA_CNT register. See the [LIN 2.1 Slave and Buffered SCI](#) section for more information about LIN/SCI communication.

Figure 113. LIN/SCI Tx Data (TX_DATAx) Registers

7	6	5	4	3	2	1	0
TX_DATAx[7]	TX_DATAx[6]	TX_DATAx[5]	TX_DATAx[4]	TX_DATAx[3]	TX_DATAx[2]	TX_DATAx[1]	TX_DATAx[0]
R/W-0	R/W-0	R/W-0	R/W-0	R/W-0	R/W-0	R/W-0	R/W-0

Table 100. TX_DATAx Register Field Descriptions

Bit	Field	Type	Reset	Description
7-0	TX_DATAx[7:0]	R/W	0	

7.6.2.35 LIN/SCI Data Count Register (offset = 0xDB) [reset = 0]

Not bit-addressable

The DATA_CNT register determines how many bytes of data will be sent from the TX_DATAx register when a LIN/SCI transmit is initiated. When in SCI mode, the minimum DATA_CNT should be. In both LIN and SCI mode, the maximum value of DATA_CNT should be 8. See the [LIN 2.1 Slave and Buffered SCI](#) section for more information about LIN/SCI communication.

Figure 114. LIN/SCI Data Count (DATA_CNT) Register

7	6	5	4	3	2	1	0
—			CNT3	CNT2	CNT1	CNT0	
R/W-0			R/W-0	R/W-0	R/W-0	R/W-0	R/W-0

Table 101. DATA_CNT Register Field Descriptions

Bit	Field	Type	Reset	Description
7-4		R/W	0	
3	CNT3	R/W	0	
2	CNT2	R/W	0	
1	CNT1	R/W	0	
0	CNT0	R/W	0	

7.6.2.36 LIN Configuration Register (offset = 0xDC) [reset = 0x40]

Not bit-addressable

The LIN_CFG register sets the checksum type used and LIN diagnostics used. See the [LIN 2.1 Slave and Buffered SCI](#) section for more information about LIN/SCI communication.

Figure 115. LIN Configuration (LIN_CFG) Register

7	6	5	4	3	2	1	0
BIT_TOL	CS_METHOD	CLR_ERR	INTERBYTE_S PC	HOLD	—	IGNORE_DIAG	—
R/W-0	R/W-1	R/W-0	R/W-0	R/W-0	R/W-0	R/W-0	R/W-0

Table 102. LIN_CFG Register Field Descriptions

Bit	Field	Type	Reset	Description
7	BIT_TOL	R/W	0	0: Normal bit-time tolerance for the STOP bit transmitted after PID and data. The nominal is 15% of the expected bit rate. 1: Doubles the bit-time tolerance to 30% for the STOP bit transmitted after PID and data.
6	CS_METHOD	R/W	1	0: Classic checksum 1: Enhanced checksum
5	CLR_ERR	R/W	0	0: Do not clear LIN error log register (LIN_STATUS). The clear occurs only between frames. 1: Clear error log register (LIN_STATUS).
4	INTERBYTE_SPC	R/W	0	0: 1 bit of inter-byte space during transmission of data bytes by PGA450-Q1 1: 2 bits of inter-byte space during transmission of data bytes by PGA450-Q1
3	HOLD	R/W	0	0: LIN frame is not ignored. 1: LIN Frame is ignored; that is, the LIN slave protocol does not process the break field.
2		R/W	0	This bit should always be written as 0; the user software should not write a 1 to this bit.
1	IGNORE_DIAG	R/W	0	0: Wait for data bytes after PID is received. 1: Wait for break field after PID is received.
0		R/W	0	This bit should always be written as 0; the user software should not write a 1 to this bit.

7.6.2.37 LIN Control Register (offset = 0xDD) [reset = 0]

Not bit-addressable

The RX_TX bit initiates a receive or transmit for LIN or SC depending on the mode currently chosen by the LIN_SCI register. See the [LIN 2.1 Slave and Buffered SCI](#) section for more information about LIN/SCI communication.

Figure 116. LIN Control (LIN_CTRL) Register

7	6	5	4	3	2	1	0
—							RX_TX
R/W-0							R/W-0

Table 103. LIN_CTRL Register Field Descriptions

Bit	Field	Type	Reset	Description
7-1		R/W	0	
0	RX_TX	R/W	0	0: Receive data on LIN bus 1: Transmit data on LIN bus

7.6.2.38 LIN STATUS Register (offset = 0xDE) [reset = 0]

Not bit-addressable

The LIN_STATUS register holds the LIN diagnostics, parity, and checksum information. See the [LIN 2.1 Slave and Buffered SCI](#) section for more information about LIN/SCI communication.

Figure 117. LIN STATUS (LIN_STATUS) Register

7	6	5	4	3	2	1	0
—	BREAK_DEL	SYNC_LONG	SYNC_SHORT	STOP_BIT_SHORT	STOP_BIT_VAL	PARITY	CHECKSUM
R-0	R-0	R-0	R-0	R-0	R-0	R-0	R-0

Table 104. LIN_STATUS Register Field Descriptions

Bit	Field	Type	Reset	Description
7		R	0	
6	BREAK_DEL	R	0	0: Break delimiter normal 1: Break delimiter is shorter than expected.
5	SYNC_LONG	R	0	0: Sync is not long. 1: Sync is longer than expected (based on fixed time of 50 μs/bit)
4	SYNC_SHORT	R	0	0: Sync is not short. 1: Sync is shorter than expected (based on fixed time of 50 μs/bit).
3	STOP_BIT_SHORT	R	0	0: Stop bit is normal. 1: Stop bit of PID and data is short (based on configuration of bit rate tolerance).
2	STOP_BIT_VAL	R	0	0: Stop bit valid 1: Stop bit was not set after 8th LIN bit was received or transmitted
1	PARITY	R	0	0: PID parity no error 1: PID parity error
0	CHECKSUM	R	0	0: Checksum normal 1: Checksum error

7.6.2.39 FIFO Pointer (FIFO_POINTER) Registers

Not bit-addressable

The FIFO pointer registers indicate the current location in the FIFO RAM read to be written to once a sample is available from the digital datapath. By checking the current status of the FIFO pointer in the PGA450-Q1 application firmware, the user can ensure that the algorithm processing the echo data in the FIFO does not surpass the valid available data.

7.6.2.39.1 FIFO Pointer MSB Register (offset = 0xDF) [reset = 0]

Figure 118. FIFO Pointer MSB (FIFO_POINTER_MSB) Register

7	6	5	4	3	2	1	0
—						FIFO_PTR[9]	FIFO_PTR[8]
R-0						R-0	R-0

Table 105. FIFO_POINTER_MSB Register Field Descriptions

Bit	Field	Type	Reset	Description
7-2		R	0	
1-0	FIFO_PTR[9:8]	R	0	

7.6.2.39.2 FIFO Pointer LSB Register (offset = 0xE1) [reset = 0]
Figure 119. FIFO Pointer LSB (FIFO_POINTER_LSB) Register

7	6	5	4	3	2	1	0
FIFO_PTR[7]	FIFO_PTR[6]	FIFO_PTR[5]	FIFO_PTR[4]	FIFO_PTR[3]	FIFO_PTR[2]	FIFO_PTR[1]	FIFO_PTR[0]
R-0	R-0	R-0	R-0	R-0	R-0	R-0	R-0

Table 106. FIFO_POINTER_LSB Register Field Descriptions

Bit	Field	Type	Reset	Description
7-0	FIFO_PTR[7:0]	R	0	

7.6.2.40 VREG Select Register (offset = 0xE2) [reset = 0]

Bit-addressable

The VREG_SEL register determines what voltage VREG will be regulated to when enabled. Note that VPWR must be at least 2 V greater than the selected VREG voltage to ensure proper VREG regulation.

Figure 120. VREG Select (VREG_SEL) Register

7	6	5	4	3	2	1	0
—	—			VREG_SEL3	VREG_SEL2	VREG_SEL1	VREG_SEL0
W-0	R/W-0			R/W-0	R/W-0	R/W-0	R/W-0

Table 107. VREG_SEL Register Field Descriptions

Bit	Field	Type	Reset	Description
7		W	0	
6-4		R/W	0	
3	VREG_SEL3	R/W	0	See Table 108 .
2	VREG_SEL2	R/W	0	See Table 108 .
1	VREG_SEL1	R/W	0	See Table 108 .
0	VREG_SEL0	R/W	0	See Table 108 .

Table 108. VREG_SELx Bit Configuration

VREG_SEL3	VREG_SEL2	VREG_SEL1	VREG_SEL0	NOMINAL VREG VOLTAGE (V)
0	0	0	0	4.7
0	0	0	1	4.8
0	0	1	0	4.9
0	0	1	1	5.0
0	1	0	0	5.1
0	1	0	1	5.2
0	1	1	0	5.3
0	1	1	1	5.4
1	0	0	0	7.7
1	0	0	1	7.8
1	0	1	0	7.9
1	0	1	1	8.0
1	1	0	0	8.1
1	1	0	1	8.2
1	1	1	0	8.3
1	1	1	1	8.4

7.6.2.41 Sync Count (SYNC_COUNT) Registers

Not bit-addressable

The SYNC_COUNT register can be used to determine the success of a LIN sync operation. This register stores the measured width of the LIN sync field. See the [Clock Synchronizer Using the SYNC Field in the LIN Bus](#) section for more details.

7.6.2.41.1 Sync Count MSB Register (offset = 0xE3) [reset = 0]

Figure 121. Sync Count MSB (SYNC_COUNT_MSB) Register

7	6	5	4	3	2	1	0
SC[15]	SC[14]	SC[13]	SC[12]	SC[11]	SC[10]	SC[9]	SC[8]
R-0	R-0	R-0	R-0	R-0	R-0	R-0	R-0

Table 109. SYNC_COUNT_MSB Register Field Descriptions

Bit	Field	Type	Reset	Description
7-0	SC[15:8]	R	0	

7.6.2.41.2 Sync Count LSB Register (offset = 0xE4) [reset = 0]

Figure 122. Sync Count LSB (SYNC_COUNT_LSB) Register

7	6	5	4	3	2	1	0
SC[7]	SC[6]	SC[5]	SC[4]	SC[3]	SC[2]	SC[1]	SC[0]
R-0	R-0	R-0	R-0	R-0	R-0	R-0	R-0

Table 110. SYNC_COUNT_LSB Register Field Descriptions

Bit	Field	Type	Reset	Description
7-0	SC[7:0]	R	0	

7.6.2.42 TEMP/DAC Control Register (offset = 0xE5) [reset = 0]

Bit-addressable

Figure 123. TEMP/DAC Control (TEMP_DAC_CTRL) Register

7	6	5	4	3	2	1	0
—	—					TS_DAC_MODE	TS_DAC_EN
W-0	R/W-0					W-0	W-0

Table 111. TEMP_DAC_CTRL Register Field Descriptions

Bit	Field	Type	Reset	Description
7		W	0	
6-2		R/W	0	
1	TS_DAC_MODE	W	0	0: Temperature sensor 1: Digital datapath
0	TS_DAC_EN	W	0	0: Temperature sensor DAC powered off 1: Temperature sensor DAC powered on

7.6.2.43 Oscillator Sync Control Register (offset = 0xE6) [reset = 0]

Bit-addressable

The OSx bits determine how much of an oscillator frequency shift is implemented. This can be determined from the LIN synchronization algorithm or directly from the 8051W application code. See [Table 3](#) for details on what frequency shifts are implemented from the OSx bits.

Figure 124. Oscillator Sync Control (OSC_SYNC_CTRL) Register

7	6	5	4	3	2	1	0
—	OVR	OS5	OS4	OS3	OS2	OS1	OS0
W-0	R/W-0	R/W-0	R/W-0	R/W-0	R/W-0	W-0	W-0

Table 112. OSC_SYNC_CTRL Register Field Descriptions

Bit	Field	Type	Reset	Description
7		W	0	
6	OVR	R/W	0	0: OS[5:0] are read-only for 8051W, clock synchronization algorithm updates OS[5:0] bits. 1: 8051W updates OS[5:0] bits, clock synchronization algorithm does not update OS[5:0] bits.
5	OS5	R/W	0	
4	OS4	R/W	0	
3	OS3	R/W	0	
2	OS2	R/W	0	
1	OS1	W	0	
0	OS0	W	0	

7.6.3 TEST Registers

7.6.3.1 ANALOG Test MUX Register (offset = 0xE9) [reset = 0]

Not bit-addressable

The AMUX register determines what the output of the DACO pin is. Both options for the DAC output are intended for development purposes as they provide ways to view the echo signal on an oscilloscope before and after the digital datapath.

Figure 125. ANALOG Test MUX (AMUX) Register

7	6	5	4	3	2	1	0
—			AMUX3	AMUX2	AMUX1	AMUX0	
R/W-0			R/W-0	R/W-0	R/W-0	R/W-0	R/W-0

Table 113. AMUX Register Field Descriptions

Bit	Field	Type	Reset	Description
7-4		R/W	0	
3	AMUX3	R/W	0	See Table 114 .
2	AMUX2	R/W	0	See Table 114 .
1	AMUX1	R/W	0	See Table 114 .
0	AMUX0	R/W	0	See Table 114 .

Table 114. AMUX3:0 Bit Configuration

AMUX3:AMUX0 (Hexadecimal)	Output on TESTO_A	Description
01	DAC OUTPUT	Digital datapath output voltage
04	LNA OUTPUT	Low-noise amplifier output

7.6.3.2 DIGITAL Test MUX Register (offset = 0xEA) [reset = 0]

Not bit-addressable

Figure 126. DIGITAL Test MUX (DMUX) Register

7	6	5	4	3	2	1	0
—			DMUX4	DMUX3	DMUX2	DMUX1	DMUX0
R/W-0			R/W-0	R/W-0	R/W-0	R/W-0	R/W-0

Table 115. DMUX Register Field Descriptions

Bit	Field	Type	Reset	Description
7-5		R/W	0	
4	DMUX4	R/W	0	See Table 116 .
3	DMUX3	R/W	0	See Table 116 .
2	DMUX2	R/W	0	See Table 116 .
1	DMUX1	R/W	0	See Table 116 .
0	DMUX0	R/W	0	See Table 116 .

Table 116. DMUX4:0 Bit Configuration

DMUX4:DMUX0 (Hexadecimal)	Output on TESTO_D	Description	Output on GPIO1	Description	Output on GPIO2	Description
01	SAT_EN	Saturation enable	SAT_DONE	Saturation Done	SAT_MON	Saturation Comparator Output
04	LIN_RXD	LIN receive			LIN_TXD	LIN Transmit
08	FIFO_UPDATE	Pulse is generated when FIFO pointer is updated.				
0A	CLK	System clock	INT_CLK	Internal Clock	EXT_CLK	External Clock

8 Application and Implementation

NOTE

Information in the following applications sections is not part of the TI component specification, and TI does not warrant its accuracy or completeness. TI's customers are responsible for determining suitability of components for their purposes. Customers should validate and test their design implementation to confirm system functionality.

8.1 Application Information

The PGA450-Q1 must be paired with an external transducer. The PGA450-Q1 drives the transducer and then filters and processes the returned echo signal sensed by the transducer. The transducer should be chosen based on the resonant frequency, input voltage requirements, sensitivity, beam pattern, and decay time. The PGA450-Q1 meets most transducer requirements by adjusting the driving frequency, driving voltage, and bandpass center frequency. The external transformer should be chosen to meet the input voltage requirements of the transducer and to have a high-enough saturation current.

The interface options include LIN, SCI, UART, and SPI. The SPI must be used when programming the memory of the PGA450-Q1, but after that any of the other interfaces can be used for communication. After a distance measurement is initiated, the PGA450-Q1 can return the measured distance through a communication interface.

8.2 Typical Application

In the typical application, the PGA450-Q1 is paired with one transducer which are located on one PCB as one sense node. Each PCB uses a three-wire interface, power, ground, and LIN. Multiple PCBs can be connected in parallel as shown in [Figure 127](#). If a different communication method is used, then more wires may be needed.

Typical Application (continued)

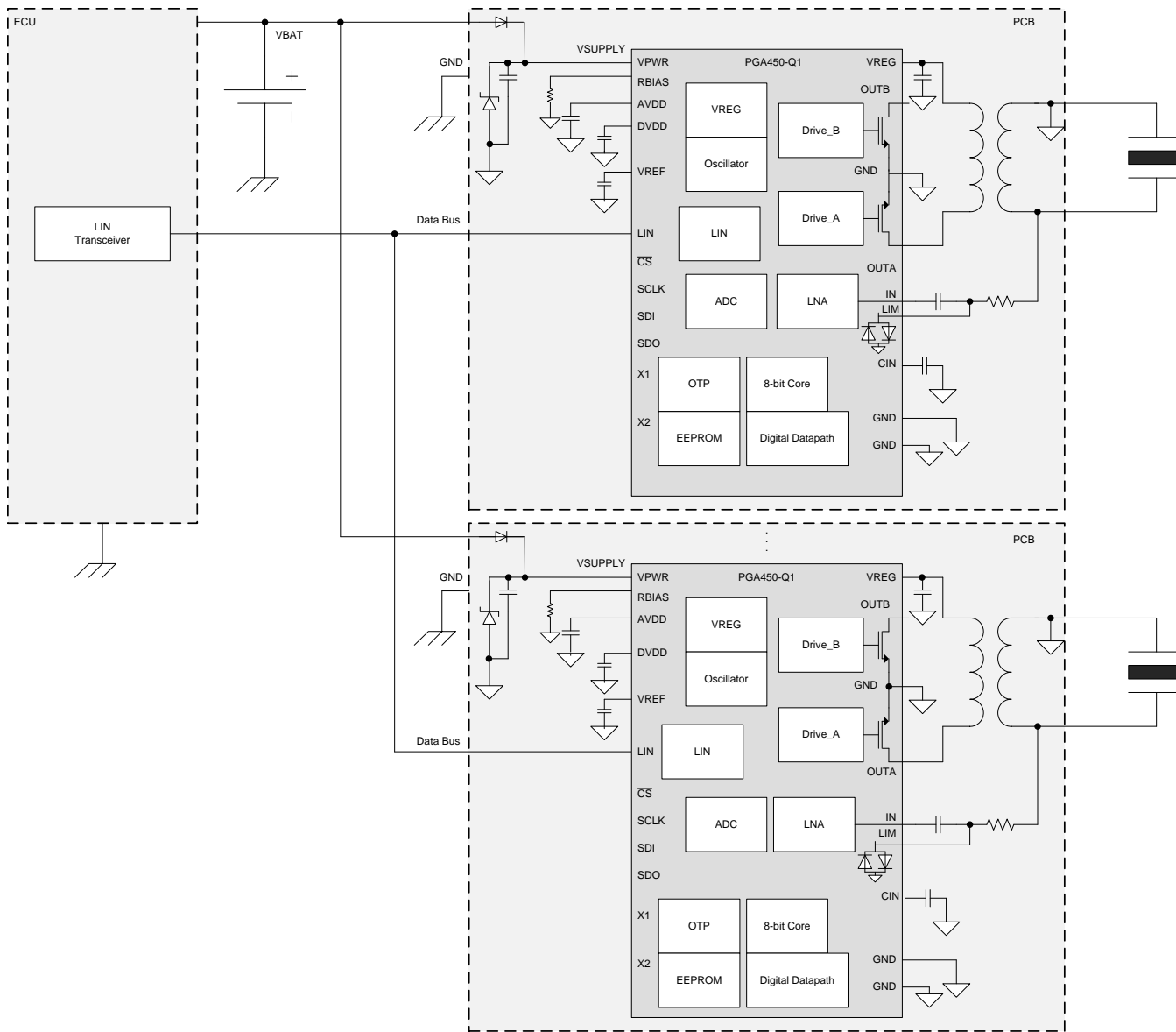

Figure 127. Typical Application Schematic

Typical Application (continued)

8.2.1 Design Parameters

For this design example, use the following parameters:

- $f_{\text{transducer}} = 58 \text{ kHz}$
- $V_{\text{PWR}} = 12 \text{ V}$
- $d_{\text{min}} = 15 \text{ cm}$
- $d_{\text{max}} = 5 \text{ m}$

8.2.2 Detailed Design Procedure

8.2.2.1 Hardware

The hardware design for the PGA450 consists of selecting a transducer and supporting passive components. When a transducer is selected, the next step in the design process is to select a transformer based on the characteristics of the transducer. Figure 128 shows the electrical model of the transducer. The secondary winding of the transformer should be selected to match the resonant frequency of the transducer. A tuning capacitor can be used to assist with this requirement.

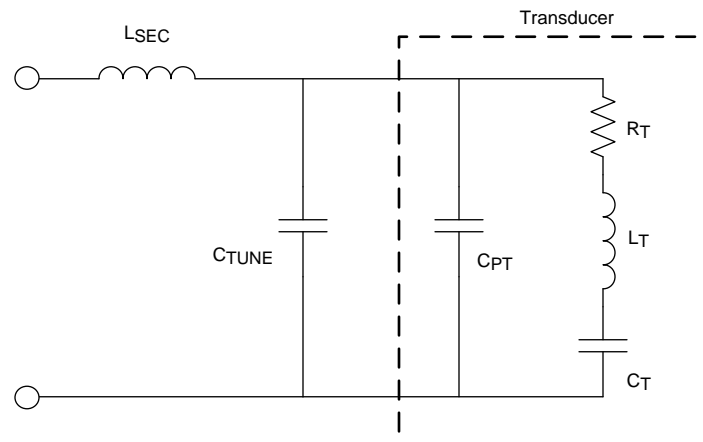

Figure 128. Transducer and Transformer Electrical Model

$$C_{\text{TUNE}} = \frac{C_{\text{T}} \times L_{\text{T}}}{L_{\text{SEC}}} - C_{\text{PT}} \quad (11)$$

The low-side drivers force a voltage across the transducers equal to the VREG voltage. Either low-side driver can be used with a single-ended transformer or a center-tapped transformer can be used with both low-side drivers for push-pull mode. Single-ended mode causes the voltage on the secondary side of the windings to be approximately the turn ratio multiplied by the VREG voltage. Push-pull mode doubles the voltage. Select the transformer, the value of VREG, and circuit configuration based on the V_{PP} value of the transducer. Also consider that as current is pulled from the VREG capacitor, the voltage at the VREG pin will droop. Finally, ensure that the transformer saturation current is sufficient.

8.2.2.2 Firmware

The PGA450-Q1 must be programmed to work with the selected transducer and can be optimized for the desired range. For this example, two different firmware settings will be used: one to optimize short-distance detection and one to optimize long-distance detection. Program the registers listed in Table 117 to program the device to work with the selected transducer.

Typical Application (continued)
Table 117. Registers to Tune for Optimization

	SHORT DISTANCE OPTIMIZATION	LONG DISTANCE OPTIMIZATION
Bandpass filter	BPF_B1_MSB = 0x03	
	BPF_B1_LSB = 0x2D	
	BPF_A2_MSB = 0xEC	
	BPF_A2_LSB = 0x3D	
	BPF_A3_MSB = 0xF9	
	BPF_A3_LSB = 0xA5	
Downsample rate	DOWNSAMPLE = 0x28	
Low-pass filter	LPF_B1_MSB = 0x2D	
	LPF_B1_LSB = 0x68	
	LPF_A2_MSB = 0x25	
	LPF_A2_LSB = 0x30	
Low-side drivers	BURST_ONA_MSB = 0x00	
	BURST_ONA_LSB = 0x8A	
	BURST_OFFA_MSB = 0x00	
	BURST_OFFA_LSB = 0x8A	
	BURST_ONB_MSB = 0x00	
	BURST_ONB_LSB = 0x8A	
	BURST_OFFB_MSB = 0x00	
	BURST_OFFB_LSB = 0x8A	
Pulse count	PULSE_CNTA = 0x01	PULSE_CNTE = 0x12
Blanking timer	BLANKING_TIMER = 0x27	BLANKING_TIMER = 0xFF
FIFO mode	FIFO_CTRL = 0x07	FIFO_CTRL = 0x06

8.2.2.2.1 Band-pass Filter Coefficients

The bandpass filter coefficients are selected by referring to [Table 6](#) and [Table 7](#). A bandwidth of 4 kHz was selected for this example. A wider bandwidth can be used if the transducer center frequency has more variation or for applications that must pick up possible frequency shifts caused by movement or environmental conditions. A wider bandwidth corresponds to more noise, therefore, the smallest bandwidth that fits the application should be selected.

- BPF_B1_MSB = 0x03
- BPF_B1_LSB = 0x2D
- BPF_A2_MSB = 0xEC
- BPF_A2_LSB = 0x3D
- BPF_A3_MSB = 0xF9
- BPF_A3_LSB = 0xA5

8.2.2.2.2 Downsample Rate

With only 768 bytes available in the FIFO RAM, the downsample rate allows some flexibility for selecting how often samples are stored. A smaller downsample rate provides more resolution but the maximum distance stored will be shorter.

$$\text{DOWNSAMPLE}_{\text{MIN}} = \frac{2 \times d_{\text{max}} \times f_s}{\text{FIFO} \times v_{\text{sound}}}$$

where

- d_{max} = maximum distance detection required of application.
- f_s = ADC sampling frequency, 1 MHz.
- FIFO = FIFO RAM memory size, 768.
- v_{sound} = speed of sound, through air at room temp = 343 m/s.

(12)

$$\text{DOWNSAMPLE}_{\text{MIN}} = \frac{2 \times 5 \text{ m} \times 1 \text{ MHz}}{768 \times 343 \text{ m/s}} = 38 \quad (13)$$

To add some margin, a downsampling rate of 40 was selected for this example, which is 0x28 in hexadecimal.

DOWNSAMPLE = 0x28

8.2.2.2.3 Low-Pass Filter Coefficients

The low-pass filter coefficients are selected by referring to [Table 8](#). For this example, a cutoff frequency of 4 kHz is used. A smaller cutoff frequency can be used to further zoom in around the center frequency of the transducer; however, ensure to consider the transducer frequency variation across process and temperature.

- LPF_B1_MSB = 0x2D
- LPF_B1_LSB = 0x68
- LPF_A2_MSB = 0x25
- LPF_A2_LSB = 0x30

8.2.2.2.4 Pulse Count

The pulse count sets the number of pulses driven by the low-side drivers per measurement burst. To optimize the minimum measurable distance, a small number of pulses should be used. To detect distances farther away, more pulses should be sent to maximize the sent signal strength.

- Short distance mode, 1 pulse:
 - PULSE_CNTA = 0x01
- Long distance mode, 16 pulses:
 - PULSE_CNTA = 0x12

8.2.2.2.5 Blanking Timer

The blanking timer setting allows the user to delay when the FIFO RAM begins storing samples. Immediately after the transducer is excited, the signal is too large to extract useful information from. To maximize the efficiency of the data stored in the FIFO, the blanking timer can be used so that this initial saturated section of data is not stored. For this example, the blanking time was selected by first examining the resulting waveform when the blanking time was 0. From this, the saturated region can be observed. Set the blanking timer to remove most of this saturated region.

- Short distance mode, set to remove the saturated echo region from the echo data:
 - BLANKING_TIMER = 0x27
- Long distance mode, maximize blanking timer to increase maximum distance:
 - BLANKING_TIMER = 0xFF

8.2.2.2.6 FIFO Mode

The digital datapath of the PGA450-Q1 is 12 bits; however, storing all 12 bits quickly uses up more of the 768 bytes of FIFO RAM which reduces the range of distances that can be measured. An alternative is to store only 8 bits in the FIFO RAM. Storing the lower 8 bits maximizes the resolution and is helpful for measuring long distances. For measuring short distances, minimizing the saturation time is important, therefore, the middle 8 bits can be used.

- Short distance mode, middle 8 bits are stored [10:3]
 - FIFO_CTRL = 0x07
- Long distance mode, lower 8 bits are stored:
 - FIFO_CTRL = 0x06

8.2.2.3 OUT_A and OUT_B On and Off Times

These on and off times dictate the driving frequency of the low-side drivers. Typically these times will match the center frequency of the transducer.

$$\text{OUT_A_ON} = \text{OUT_A_OFF} = \text{OUT_B_ON} = \text{OUT_B_OFF} = \frac{F_{\text{OSC}}}{2 \times f_{\text{transducer}}} = 0x8A \quad (14)$$

8.2.3 Application Curves

These application curves show the results of using the settings derived above to measure a 1-m tall, 76-mm wide PVC pipe at various distances. Several runs are plotted on top of each other. The y-axis shows the signal strength of the returned signal and the x-axis shows the distance. To determine where the object is located, a threshold can be used to compare the amplitude of the echo data at each FIFO memory location. When the incoming data surpasses the threshold, the PGA450-Q1 can flag that location as the measured distance. This threshold scheme must be programmed into the microcontroller of the PGA450-Q1.

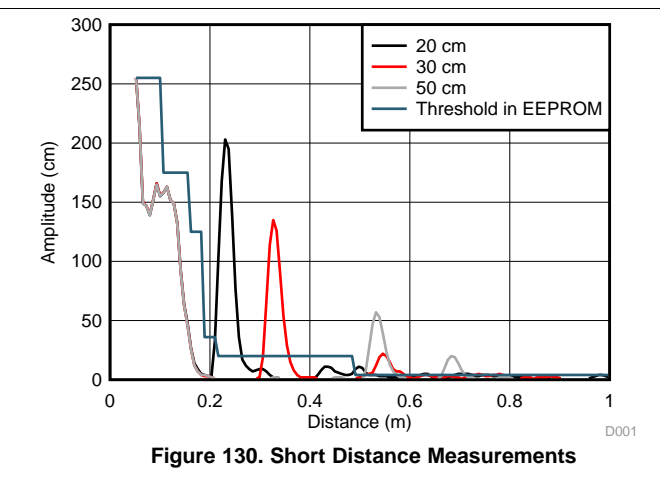
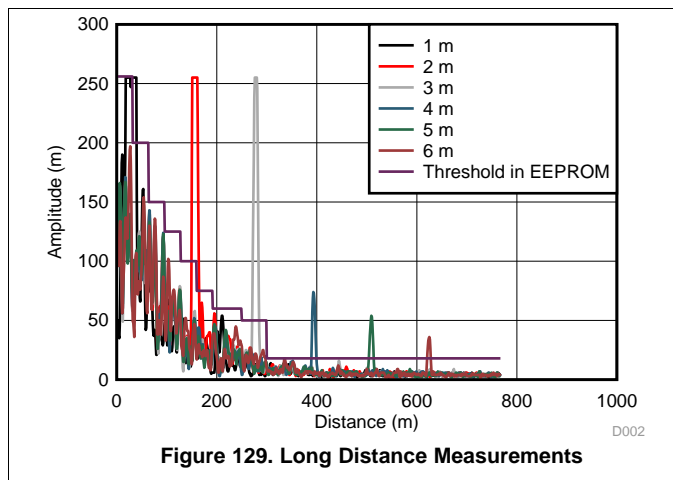

9 Power Supply Recommendations

The PGA450-Q1 can operate from a 7- to 18-V power supply. The device can be connected directly to a battery through a reverse battery-protection diode. The ramp-down rate of the power supply must be faster than 1V/ms so that the AVDD UV flag remains valid. Read SLDA028 for a full description of this requirement.

The VREG pin can be programmed to regulate from 4.7 to 8.4 V. The VPWR supply voltage must be 2-V greater than the VREG voltage to ensure proper regulation.

10 Layout

10.1 Layout Guidelines

The grounding scheme of the PGA450-Q1 must be planned to reduce noise interference. In particular, the transducer and supporting circuitry should each have a ground plane connected to the main ground at one point. The LIN line should have a separate ground as well which should also be connected to the main ground at one point. This separate ground for LIN is only necessary if a capacitor from the LIN pin to ground is put on the PGA450 PCB. The third grounding network should include everything else, including the power ground.

The PCB trace should go from the LIN pin to the PCB connector in as direct a route as possible to reduce any possible noise interference. The most noise-sensitive portion of the application circuit is from the transducer to the IN and LIM pins. This layout should be as direct as possible and should avoid crossing any noisy signal paths.

10.2 Layout Example

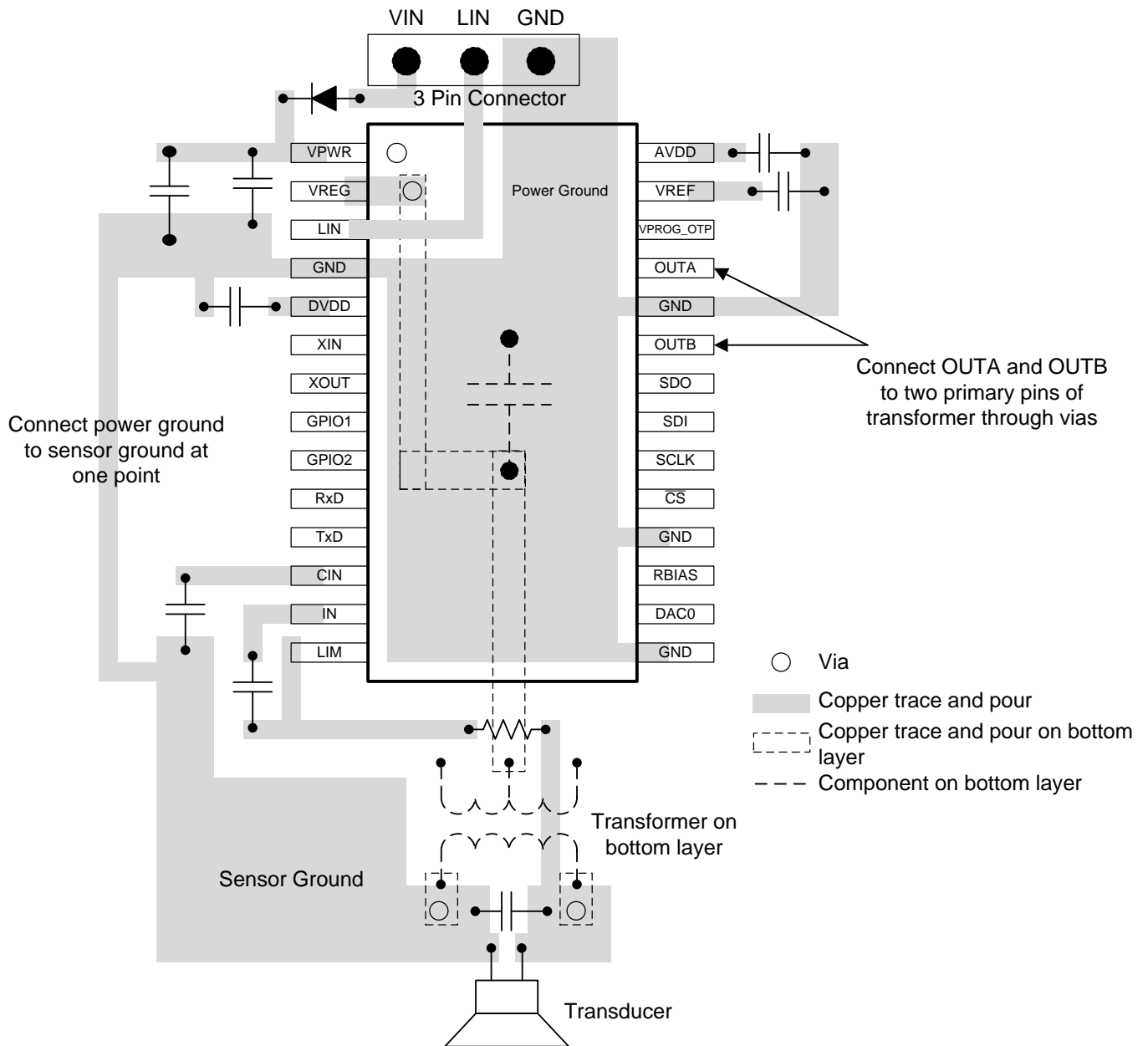

Figure 131. PGA450-Q1 Layout Example

11 Device and Documentation Support

11.1 Documentation Support

11.1.1 Related Documentation

For related documentation see the following:

- *Automatic Slave Node Position Detection (SNPD)*, [SLDA038](#)
- *LIN Demonstration Using PGA450Q1EVM Firmware Rev 2.1*, [SLDA035](#)
- *Optimizing Performance of the PGA450-Q1*, [SLDA037](#)
- *PGA450-Q1 EVM User's Guide*, [SLDU007](#)
- *PGA450Q1EVM-S User's Guide and TIDA-00151 UART Demo Instructional*, [SLDU019](#)
- *PGA450-Q1 Reset Issue During VPWR Ramp Down*, [SLDA028](#)

11.2 Community Resource

The following links connect to TI community resources. Linked contents are provided "AS IS" by the respective contributors. They do not constitute TI specifications and do not necessarily reflect TI's views; see TI's [Terms of Use](#).

TI E2E™ Online Community *TI's Engineer-to-Engineer (E2E) Community*. Created to foster collaboration among engineers. At [e2e.ti.com](#), you can ask questions, share knowledge, explore ideas and help solve problems with fellow engineers.

Design Support *TI's Design Support* Quickly find helpful E2E forums along with design support tools and contact information for technical support.

11.3 Trademarks

E2E is a trademark of Texas Instruments.

All other trademarks are the property of their respective owners.

11.4 Electrostatic Discharge Caution



These devices have limited built-in ESD protection. The leads should be shorted together or the device placed in conductive foam during storage or handling to prevent electrostatic damage to the MOS gates.

11.5 Glossary

[SLYZ022](#) — *TI Glossary*.

This glossary lists and explains terms, acronyms, and definitions.

12 Mechanical, Packaging, and Orderable Information

The following pages include mechanical, packaging, and orderable information. This information is the most current data available for the designated devices. This data is subject to change without notice and revision of this document. For browser-based versions of this data sheet, refer to the left-hand navigation.

PACKAGING INFORMATION

Orderable Device	Status (1)	Package Type	Package Drawing	Pins	Package Qty	Eco Plan (2)	Lead/Ball Finish (6)	MSL Peak Temp (3)	Op Temp (°C)	Device Marking (4/5)	Samples
PGA450TPWRQ1	ACTIVE	TSSOP	PW	28	2000	Green (RoHS & no Sb/Br)	CU NIPDAU	Level-2-260C-1 YEAR	-40 to 125	PGA450	Samples

(1) The marketing status values are defined as follows:

ACTIVE: Product device recommended for new designs.

LIFEBUY: TI has announced that the device will be discontinued, and a lifetime-buy period is in effect.

NRND: Not recommended for new designs. Device is in production to support existing customers, but TI does not recommend using this part in a new design.

PREVIEW: Device has been announced but is not in production. Samples may or may not be available.

OBSOLETE: TI has discontinued the production of the device.

(2) Eco Plan - The planned eco-friendly classification: Pb-Free (RoHS), Pb-Free (RoHS Exempt), or Green (RoHS & no Sb/Br) - please check <http://www.ti.com/productcontent> for the latest availability information and additional product content details.

TBD: The Pb-Free/Green conversion plan has not been defined.

Pb-Free (RoHS): TI's terms "Lead-Free" or "Pb-Free" mean semiconductor products that are compatible with the current RoHS requirements for all 6 substances, including the requirement that lead not exceed 0.1% by weight in homogeneous materials. Where designed to be soldered at high temperatures, TI Pb-Free products are suitable for use in specified lead-free processes.

Pb-Free (RoHS Exempt): This component has a RoHS exemption for either 1) lead-based flip-chip solder bumps used between the die and package, or 2) lead-based die adhesive used between the die and leadframe. The component is otherwise considered Pb-Free (RoHS compatible) as defined above.

Green (RoHS & no Sb/Br): TI defines "Green" to mean Pb-Free (RoHS compatible), and free of Bromine (Br) and Antimony (Sb) based flame retardants (Br or Sb do not exceed 0.1% by weight in homogeneous material)

(3) MSL, Peak Temp. - The Moisture Sensitivity Level rating according to the JEDEC industry standard classifications, and peak solder temperature.

(4) There may be additional marking, which relates to the logo, the lot trace code information, or the environmental category on the device.

(5) Multiple Device Markings will be inside parentheses. Only one Device Marking contained in parentheses and separated by a "~" will appear on a device. If a line is indented then it is a continuation of the previous line and the two combined represent the entire Device Marking for that device.

(6) Lead/Ball Finish - Orderable Devices may have multiple material finish options. Finish options are separated by a vertical ruled line. Lead/Ball Finish values may wrap to two lines if the finish value exceeds the maximum column width.

Important Information and Disclaimer: The information provided on this page represents TI's knowledge and belief as of the date that it is provided. TI bases its knowledge and belief on information provided by third parties, and makes no representation or warranty as to the accuracy of such information. Efforts are underway to better integrate information from third parties. TI has taken and continues to take reasonable steps to provide representative and accurate information but may not have conducted destructive testing or chemical analysis on incoming materials and chemicals. TI and TI suppliers consider certain information to be proprietary, and thus CAS numbers and other limited information may not be available for release.

In no event shall TI's liability arising out of such information exceed the total purchase price of the TI part(s) at issue in this document sold by TI to Customer on an annual basis.

PW (R-PDSO-G28)

PLASTIC SMALL OUTLINE

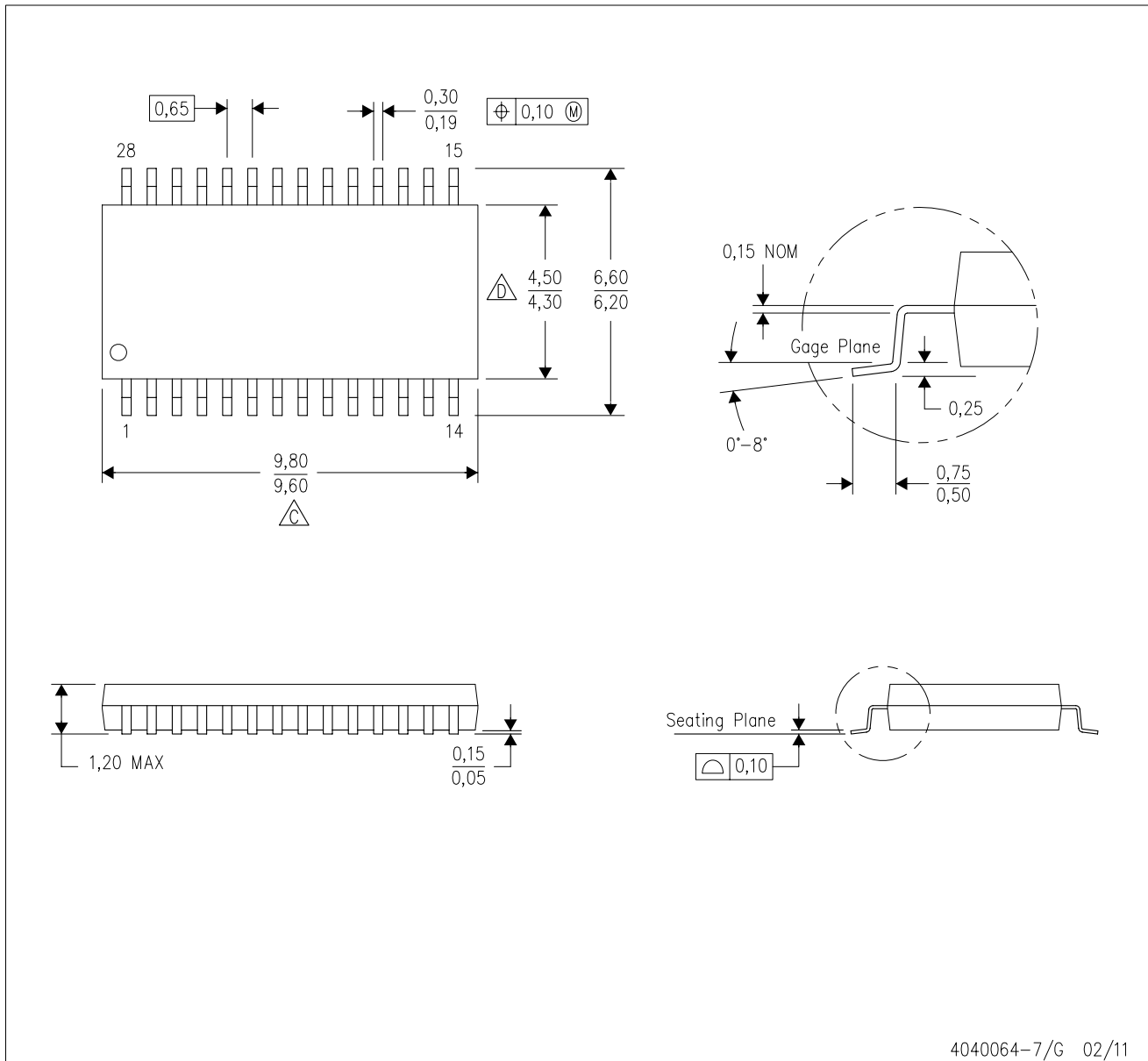

4040064-7/G 02/11

- NOTES:
- A. All linear dimensions are in millimeters. Dimensioning and tolerancing per ASME Y14.5M-1994.
 - B. This drawing is subject to change without notice.
 - C. Body length does not include mold flash, protrusions, or gate burrs. Mold flash, protrusions, or gate burrs shall not exceed 0,15 each side.
 - D. Body width does not include interlead flash. Interlead flash shall not exceed 0,25 each side.
 - E. Falls within JEDEC MO-153

PW (R-PDSO-G28)

PLASTIC SMALL OUTLINE

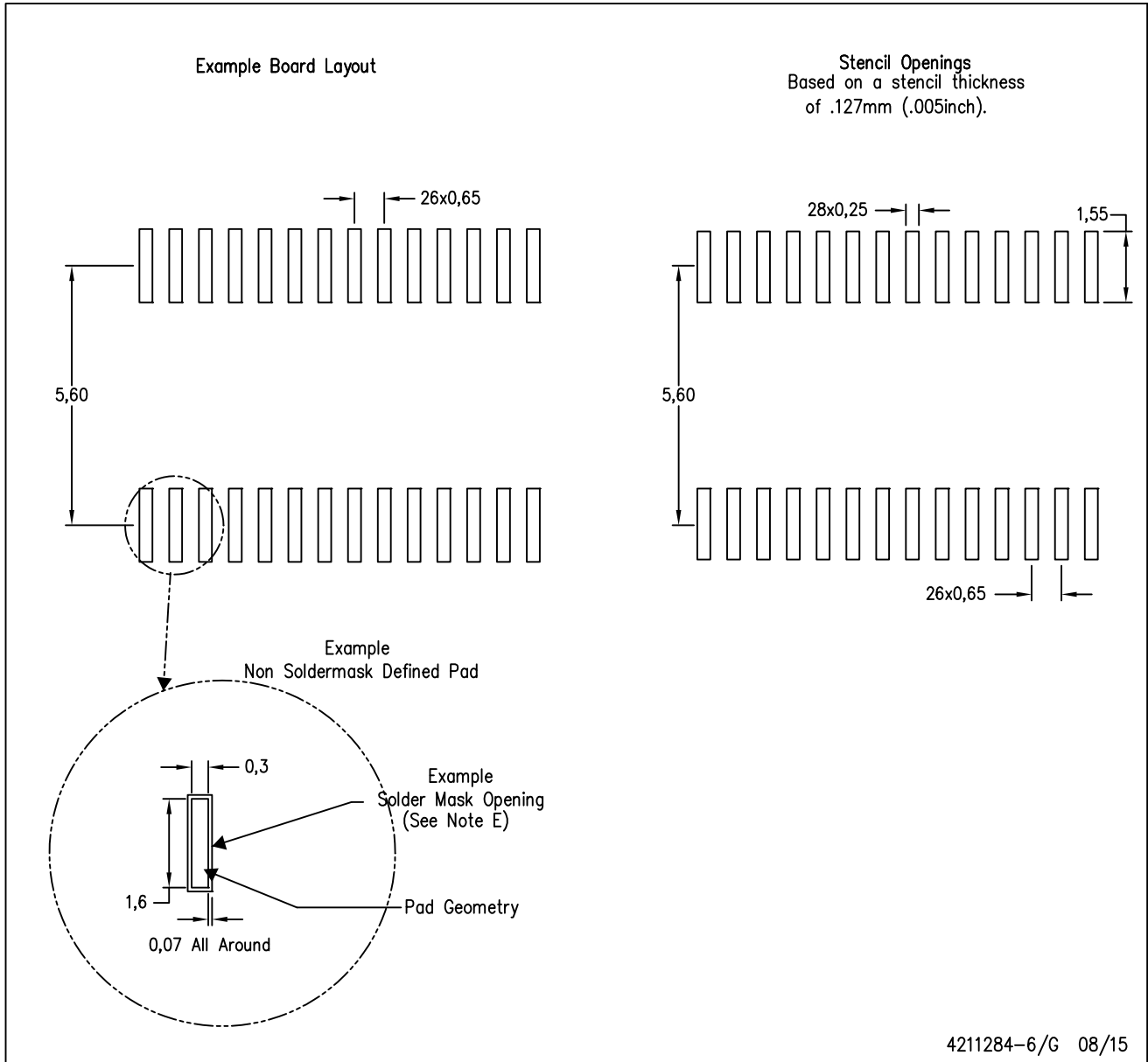

- NOTES:
- A. All linear dimensions are in millimeters.
 - B. This drawing is subject to change without notice.
 - C. Publication IPC-7351 is recommended for alternate design.
 - D. Laser cutting apertures with trapezoidal walls and also rounding corners will offer better paste release. Customers should contact their board assembly site for stencil design recommendations. Refer to IPC-7525 for other stencil recommendations.
 - E. Customers should contact their board fabrication site for solder mask tolerances between and around signal pads.

IMPORTANT NOTICE

Texas Instruments Incorporated and its subsidiaries (TI) reserve the right to make corrections, enhancements, improvements and other changes to its semiconductor products and services per JESD46, latest issue, and to discontinue any product or service per JESD48, latest issue. Buyers should obtain the latest relevant information before placing orders and should verify that such information is current and complete. All semiconductor products (also referred to herein as "components") are sold subject to TI's terms and conditions of sale supplied at the time of order acknowledgment.

TI warrants performance of its components to the specifications applicable at the time of sale, in accordance with the warranty in TI's terms and conditions of sale of semiconductor products. Testing and other quality control techniques are used to the extent TI deems necessary to support this warranty. Except where mandated by applicable law, testing of all parameters of each component is not necessarily performed.

TI assumes no liability for applications assistance or the design of Buyers' products. Buyers are responsible for their products and applications using TI components. To minimize the risks associated with Buyers' products and applications, Buyers should provide adequate design and operating safeguards.

TI does not warrant or represent that any license, either express or implied, is granted under any patent right, copyright, mask work right, or other intellectual property right relating to any combination, machine, or process in which TI components or services are used. Information published by TI regarding third-party products or services does not constitute a license to use such products or services or a warranty or endorsement thereof. Use of such information may require a license from a third party under the patents or other intellectual property of the third party, or a license from TI under the patents or other intellectual property of TI.

Reproduction of significant portions of TI information in TI data books or data sheets is permissible only if reproduction is without alteration and is accompanied by all associated warranties, conditions, limitations, and notices. TI is not responsible or liable for such altered documentation. Information of third parties may be subject to additional restrictions.

Resale of TI components or services with statements different from or beyond the parameters stated by TI for that component or service voids all express and any implied warranties for the associated TI component or service and is an unfair and deceptive business practice. TI is not responsible or liable for any such statements.

Buyer acknowledges and agrees that it is solely responsible for compliance with all legal, regulatory and safety-related requirements concerning its products, and any use of TI components in its applications, notwithstanding any applications-related information or support that may be provided by TI. Buyer represents and agrees that it has all the necessary expertise to create and implement safeguards which anticipate dangerous consequences of failures, monitor failures and their consequences, lessen the likelihood of failures that might cause harm and take appropriate remedial actions. Buyer will fully indemnify TI and its representatives against any damages arising out of the use of any TI components in safety-critical applications.

In some cases, TI components may be promoted specifically to facilitate safety-related applications. With such components, TI's goal is to help enable customers to design and create their own end-product solutions that meet applicable functional safety standards and requirements. Nonetheless, such components are subject to these terms.

No TI components are authorized for use in FDA Class III (or similar life-critical medical equipment) unless authorized officers of the parties have executed a special agreement specifically governing such use.

Only those TI components which TI has specifically designated as military grade or "enhanced plastic" are designed and intended for use in military/aerospace applications or environments. Buyer acknowledges and agrees that any military or aerospace use of TI components which have **not** been so designated is solely at the Buyer's risk, and that Buyer is solely responsible for compliance with all legal and regulatory requirements in connection with such use.

TI has specifically designated certain components as meeting ISO/TS16949 requirements, mainly for automotive use. In any case of use of non-designated products, TI will not be responsible for any failure to meet ISO/TS16949.

Products

Audio	www.ti.com/audio
Amplifiers	amplifier.ti.com
Data Converters	dataconverter.ti.com
DLP® Products	www.dlp.com
DSP	dsp.ti.com
Clocks and Timers	www.ti.com/clocks
Interface	interface.ti.com
Logic	logic.ti.com
Power Mgmt	power.ti.com
Microcontrollers	microcontroller.ti.com
RFID	www.ti-rfid.com
OMAP Applications Processors	www.ti.com/omap
Wireless Connectivity	www.ti.com/wirelessconnectivity

Applications

Automotive and Transportation	www.ti.com/automotive
Communications and Telecom	www.ti.com/communications
Computers and Peripherals	www.ti.com/computers
Consumer Electronics	www.ti.com/consumer-apps
Energy and Lighting	www.ti.com/energy
Industrial	www.ti.com/industrial
Medical	www.ti.com/medical
Security	www.ti.com/security
Space, Avionics and Defense	www.ti.com/space-avionics-defense
Video and Imaging	www.ti.com/video

TI E2E Community

e2e.ti.com

Looking for pricing, stock, or lifecycle information?

Click below to explore more details on WIN SOURCE:

 [View PGA450TPWRQ1](#) on WIN SOURCE

 [Texas Instruments](#) Information

Optimize Your Supply Chain with WIN SOURCE Solutions

-  Global Sourcing Solution
-  Obsolete Management
-  Cost Control Management
-  Shortage Management
-  Alternative Solution
-  Excess Inventory Management