



THE DATASHEET OF LNBH26PQR



Dual LNBS supply and control IC with step-up and I²C interface

Features

- Complete interface between LNB and I²C bus
- Built-in DC-DC converter for single 12 V supply operation and high efficiency (typ. 93% @ 0.5 A)
- Selectable output current limit by external resistor
- Compliant with main satellite receivers output voltage specification (15 programmable levels)
- Accurate built-in 22 kHz tone generator suits widely accepted standards
- 22 kHz tone waveform integrity guaranteed also at no load condition
- Low drop post regulator and high efficiency step-up PWM with integrated power N-MOS allowing low power losses
- LPM function (low power mode) to reduce dissipation
- Overload and overtemperature internal protection with I²C diagnostic bits
- LNB short-circuit dynamic protection
- +/- 4 kV ESD tolerant on output power pins

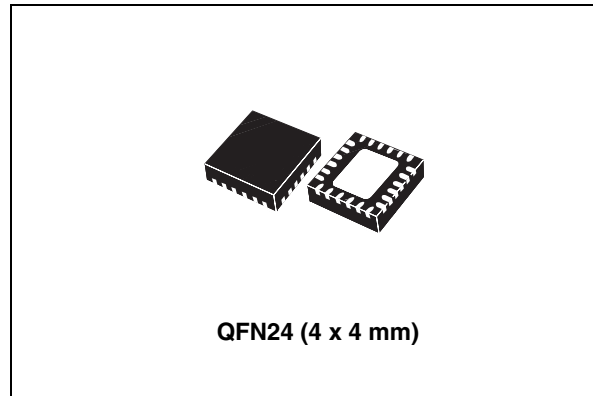

Description

Intended for analog and digital dual satellite receivers/Sat-TV, and Sat-PC cards, the LNBH26 is a monolithic voltage regulator and interface IC, assembled in QFN24 4x4 specifically designed to provide the 13/18 V power supply and the 22 kHz tone signalling to the LNB down-converter in the antenna dishes or to the multi-switch box. In this application field, it offers a complete solution for dual tuner satellite receivers with extremely low component count, low power dissipation together with simple design and I²C standard interfacing.

Applications

- STB satellite receivers
- TV satellite receivers
- PC card satellite receivers

Table 1. Device summary

Order code	Package	Packaging
LNBH26PQR	QFN24 (4 x 4)	Tape and reel

Contents

1	Block diagram	3
2	Application information (valid for each section A/B)	4
2.1	DISEQC™ data encoding (DSQIN pin)	4
2.2	Data encoding by external 22 kHz tone TTL signal	4
2.3	Data encoding by external DiSEqC envelope control through the DSQIN pin	5
2.4	LPM (low power mode)	5
2.5	DISEQC™ 2.0 implementation	5
2.6	Output current limit selection	6
2.7	Output voltage selection	6
2.8	Diagnostic and protection functions	6
2.9	Surge protections and TVS diodes	7
2.10	FLT: Fault FLAG	7
2.11	VMON: output voltage diagnostic	7
2.12	TMON: 22 kHz tone diagnostic	8
2.13	TDET: 22 kHz tone detection	8
2.14	IMON: minimum output current diagnostic	8
2.15	PDO: overcurrent detection on output pull-down stage	8
2.16	Power-on I ² C interface reset and undervoltage lockout	8
2.17	PNG: input voltage minimum detection	9
2.18	ISW: inductor switching current limit	9
2.19	COMP: boost capacitor ESR	9
2.20	OLF: overcurrent and short-circuit protection and diagnostic	9
2.21	OTF: thermal protection and diagnostic	10
3	Pin configuration	11
4	Maximum ratings	15
5	Typical application circuits	16
6	I²C bus interface	18

6.1	Data validity	18
6.2	Start and stop condition	18
6.3	Byte format	18
6.4	Acknowledge	18
6.5	Transmission without acknowledge	18
7	I²C interface protocol	20
7.1	Write mode transmission	20
7.2	Read mode transmission	21
7.3	Data registers	22
7.4	Status registers	26
8	Electrical characteristics	28
8.1	Output voltage selection	30
9	Package mechanical data	33
10	Revision history	37

1 Block diagram

Figure 1. Block diagram

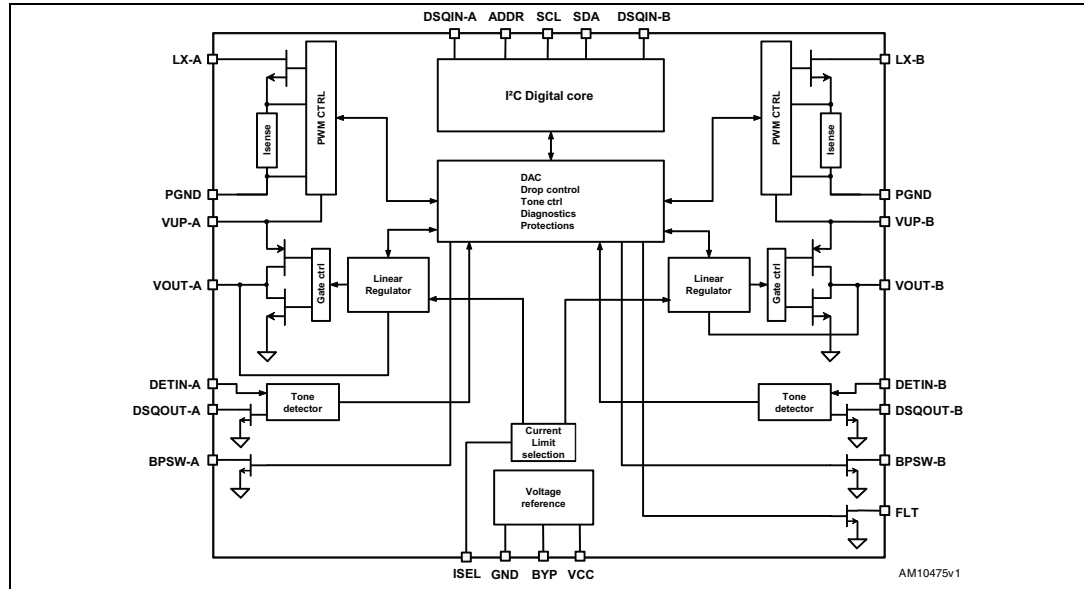

2 Application information (valid for each section A/B)

The LNBH26 includes two completely independent sections. Except for ISEL, V_{CC} and I²C inputs, each circuit can be separately controlled and have their independent external components. All the specifications below must be considered equal for both sections (A/B).

This IC has a built-in DC-DC step-up converter that, from a single source (8 V to 16 V), generates the voltages (V_{UP}) that let the integrated LDO post-regulator (generating the 13 V / 18 V LNB output voltages plus the 22 kHz DiSEqC™ tone) work with a minimum dissipated power of 0.5 W typ. @ 500 mA load (the LDO drop voltage is internally kept at $V_{UP} - V_{OUT} = 1$ V typ.). The LDO power dissipation can be further reduced when 22 kHz tone output is disabled by setting the LPM bit to “1” (see LPM function description). The IC is also provided with an undervoltage lockout circuit that disables the whole circuit when the supplied V_{CC} drops below a fixed threshold (4.7 V typ.). The step-up converter soft-start function reduces the in-rush current during startup. The SS time is internally fixed at 4 ms typ. to switch from 0 to 13 V, and 6 ms typ. to switch from 0 to 18 V.

2.1 DiSEqC™ data encoding (DSQIN pin)

The internal 22 kHz tone generator is factory trimmed in accordance with the DiSEqC™ standards, and can be activated in 3 different ways:

1. by an external 22 kHz source DiSEqC™ data connected to the DSQIN logic pin (TTL compatible). In this case the I²C tone control bits must be set: EXTM=TEN=1.
2. by an external DiSEqC™ data envelope source connected to the DSQIN logic pin. In this case the I²C tone control bits must be set: EXTM=0 and TEN=1.
3. through the TEN I²C bit if the 22 kHz presence is requested in continuous mode. In this case the DSQIN TTL pin must be pulled HIGH and the EXTM bit set to “0”.

Each of the above solutions requires that during the 22 kHz tone activation and/or DiSEqC™ data transmission, the LPM bit must be set to “0” [see [2.4: LPM \(low power mode\)](#)].

2.2 Data encoding by external 22 kHz tone TTL signal

In order to improve design flexibility an external tone signal can be input to the DSQIN pin by setting the EXTM bit to “1”.

The DSQIN is a logic input pin which activates the 22 kHz tone to the V_{OUT} pin, by using the LNBH26 integrated tone generator.

The output tone waveforms are internally controlled by the LNBH26 tone generator in terms of rise/fall time and tone amplitude, while, the external 22 kHz signal on the DSQIN pin is used to define the frequency and the duty cycle of the output tone. A TTL compatible 22 kHz signal is required for the proper control of the DSQIN pin function. Before sending the TTL signal on the DSQIN pin, the EXTM and TEN bits must be previously set to “1”. As soon as the DSQIN internal circuit detects the 22 kHz TTL external signal code, the LNBH26 activates the 22 kHz tone on the V_{OUT} output with about 1 μ s delay from TTL signal activation, and it stops with about 60 μ s delay after the 22 kHz TTL signal on DSQIN has expired (refer to [Figure 2](#)).

Figure 2. Tone enable and disable timing (using external waveform)

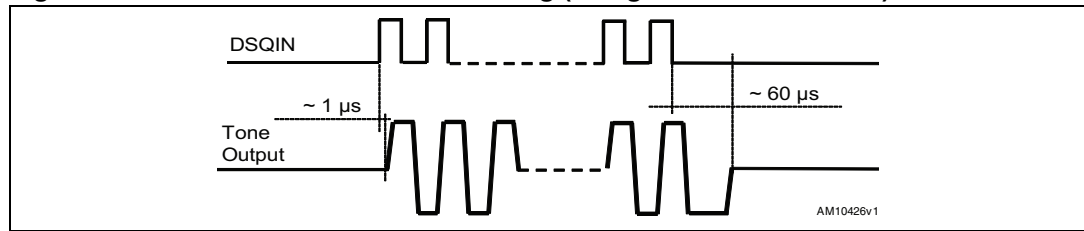

2.3 Data encoding by external DiSEqC envelope control through the DSQIN pin

If an external DiSEqC™ envelope source is available, it is possible to use the internal 22 kHz generator activated during the tone transmission by connecting the DiSEqC™ envelope source to the DSQIN pin. In this case the I²C tone control bits must be set: EXT_M=0 and TEN=1. In this way the internal 22 kHz signal is superimposed on the V_{OUT} DC voltage to generate the LNB output 22 kHz tone. During the period in which the DSQIN is kept HIGH the internal control circuit activates the 22 kHz tone output.

The 22 kHz tone on the V_{OUT} pin is activated with a delay of about 6 μs from DSQIN TTL signal rising edge, and it stops with a delay time in the range of 15 μs to 60 μs after the 22 kHz TTL signal on DSQIN has expired (refer to [Figure 3](#)).

Figure 3. Tone enable and disable timing (using envelope signal)

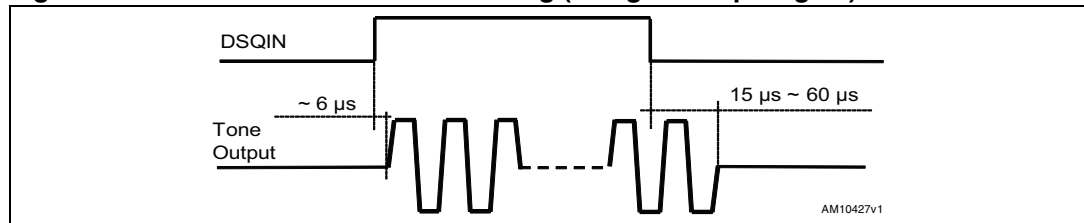

2.4 LPM (low power mode)

In order to reduce total power loss, each section of the LNBH26 is provided with the LPM I²C bit that can be activated (LPM=1) in applications where the 22 kHz tone can be disabled for long time periods. The LPM bit can be set to “1” when the DiSEqC™ data transmission is not requested (no 22 kHz tone output is present); in this condition the drop voltage across the integrated LDO regulator (V_{UP} - V_{OUT}) is reduced to 0.6 V typ. and, consequently, the power loss inside the relative LNBH26 channel regulator is reduced too. For example, at 500 mA load, LPM=1, allowing a minimum LDO dissipated power of 0.3 W typ. It is recommended to set the LPM bit to “0” before starting the 22 kHz DiSEqC™ data transmission; in this condition the drop voltage across the LDO is kept to 1 V typ. Keep LPM=0 at all times in case the LPM function is not used.

2.5 DISEQC™ 2.0 implementation

The built-in 22 kHz tone detector completes the fully bi-directional DiSEqC™ 2.0 interfacing. Each LNBH26 section DETIN pin must be AC coupled to the DiSEqC™ bus, and extracted PWK data is available on the corresponding DSQOUT pin. To comply with the bi-directional DiSEqC™ 2.0 bus hardware requirements, an output R-L filter is needed (per each voltage

output pin). In order to avoid 22 kHz waveform distortion during tone transmission, each LNBH26 section is provided with a BPSW pin to be connected to an external transistor, which allows the bypassing of the corresponding output RL filter in DiSEqC 2.x applications while in transmission mode. Before starting tone transmission by means of the DSQIN pin, provide that the TEN bit is preventively set to “1” and after ending tone transmission, provide that the TEN bit is set to “0”.

2.6 Output current limit selection

The linear regulators current limit threshold can be set by an external resistor connected to the ISEL pin. The resistor value defines the output current limit by the equation:

Equation 1

$$I_{MAX}(typ.) = \frac{16578}{RSEL^{1.206}}$$

with ISET=0

Equation 2

$$I_{MAX}(typ.) = \frac{6452}{RSEL^{1.159}}$$

with ISET=1

(Refer also to the ISET bit description in [Table 9](#).)

where RSEL is the resistor connected between ISEL and GND expressed in kΩ and $I_{MAX}(typ.)$ is the typical current limit threshold expressed in mA. I_{MAX} can be set up to 1 A for each channel. However, it is recommended to not exceed, for a long period, a total amount of current of 1 A from both sections ($I_{OUT_A} + I_{OUT_B} < 1$ A) in order to avoid the overtemperature protection triggering and to thoroughly validate the PCB layout thermal management in real application environment conditions.

2.7 Output voltage selection

Each linear regulator channel output voltage level can be easily programmed in order to accomplish application specific requirements, using 4 + 4 bits of an internal DATA1 register (see [Section 7.3: Data registers](#) and [Table 14: Output voltage selection table \(Data1 register, write mode\)](#) for exact programmable values). Register writing is accessible via the I²C bus.

2.8 Diagnostic and protection functions

The LNBH26 has 14 diagnostic internal functions provided via the I²C bus, by reading 14 bits on two STATUS registers (in read mode). All the diagnostic bits are, in normal operation (that is, no failure detected), set to LOW. One diagnostic bit is dedicated to the overtemperature status (OTF), one bit is dedicated to the input voltage power not good function (PNG), while the remaining 12 bits (6 per channel) are dedicated to the overload

protection status (OLF), to the output voltage level (VMON), to 22 kHz tone characteristics (TMON), to the minimum load current (IMON), to external voltage source presence on the V_{OUT} pin (PDO), and to 22 kHz tone presence on the DETIN pin (TDET). Once the OLF (or the OTF or PNG) bit has been activated (set to “1”), it is latched to “1” until the relevant cause is removed and a new register reading operation is done.

2.9 Surge protections and TVS diodes

Each LNBH26 device section is directly connected to the antenna cable in a set-top box. Atmospheric phenomenon can cause high voltage discharges on the antenna cable causing damage to the attached devices. Surge pulses occur due to direct or indirect lightning strikes to an external (outdoor) circuit. This leads to currents or electromagnetic fields causing high voltage or current transients. Transient voltage suppressor (TVS) devices are usually used, as shown in the following schematic (Figure 4), to protect each section of STB output circuits where the LNBH26 and other devices are electrically connected to the antenna cable.

Figure 4. Surge protection circuit

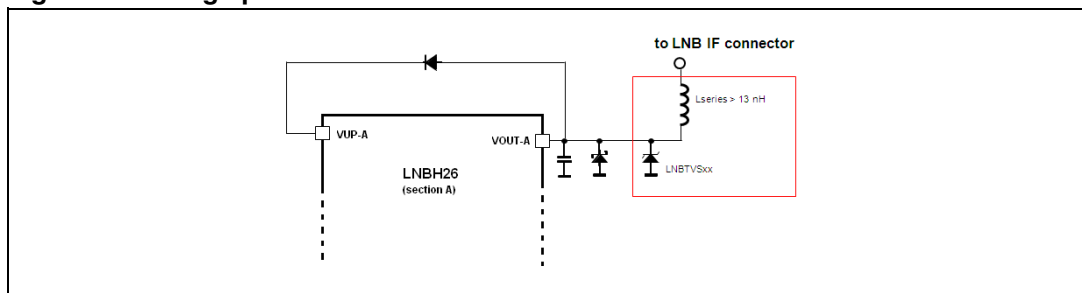

For this purpose we recommend the use of LNBTVSxx surge protection diodes specifically designed by ST. The selection of the LNBTVS diode should be made based on the maximum peak power dissipation that the diode is capable of supporting (see the LNBTVS datasheet for further details).

2.10 FLT: Fault FLAG

In order to get an immediate feedback on a diagnostic status, the LNBH26 is equipped with a dedicated fault flag pin (FLT). In the case an overload (OLF bit=1), overheating (OTF bit=1) or power not good (PNG bit=1) condition is detected, the FLT pin (open drain output) is set to low and is kept low until the relevant activating diagnostic bit is cleared. Be aware that diagnostic bits OLF, OTF and PNG, once activated, are kept latched to “1” until the origin cause is removed and a new register reading operation is performed by the microprocessor. The FLT pin must be connected to a positive voltage (5 V max.) by means of a pull-up resistor.

2.11 VMON: output voltage diagnostic

When one device output voltage is activated (V_{OUT} pin), its value is internally monitored and, as long as the output voltage level is below the guaranteed limits, the relevant VMON I²C bit is set to “1” (see Table 17 for more details).

2.12 TMON: 22 kHz tone diagnostic

The 22 kHz tone can be internally detected and monitored if one (or both) DETIN pin are connected to the LNB output bus (see [Figure 7](#)) through a decoupling capacitor.

The tone diagnostic function is provided with the corresponding TMON I²C bit. If the 22 kHz tone amplitude and/or the tone frequency is out of the guaranteed limits (see [Table 19](#)), the corresponding TMON I²C bit is set to “1”.

2.13 TDET: 22 kHz tone detection

When a 22 kHz tone presence is detected on one DETIN pin, the corresponding TDET I²C bit is set to “1”.

2.14 IMON: minimum output current diagnostic

In order to detect the output load absence (no LNB connected on the bus or cable not connected to the IRD) each LNBH26 section is provided with a minimum output current flag by the corresponding IMON I²C bit, accessible in read mode, which is set to “1” if the output current is lower than 12 mA (typ.). It is recommended to use the IMON function only with the 22 kHz tone transmission deactivated, otherwise the IMON bit could be set to “0” even if the output current is below the minimum current threshold. To activate the IMON diagnostic function, set to “1” the EN_IMON I²C bit in the DATA4 register. Be aware that as soon as the IMON function is activated by means of EN_IMON=1, the V_{OUT} is immediately increased to 21 V (typ.) independently on the VSEL bit setting. This operation is applied in order to be sure that the LNBH26 output has the higher voltage present in the LNB bus. Do not use this function in an application environment where a 21 V voltage level is not supported by other peripherals connected to the LNB bus.

2.15 PDO: overcurrent detection on output pull-down stage

When an overcurrent occurs on one section pull-down output stage due to an external voltage source greater than the LNBH26 nominal V_{OUT}, and for a time longer than I_{SINK_TIME_OUT} (10 ms typ.), the corresponding PDO I²C bit is set to “1”. This may happen due to an external voltage source presence on the LNB output (V_{OUT} pin).

For current threshold and deglitch time details, see [Table 13](#).

2.16 Power-on I²C interface reset and undervoltage lockout

The I²C interface built into the LNBH26 is automatically reset at power-on. As long as the V_{CC} stays below the undervoltage lockout (UVLO) threshold (4.7 V typ.), the interface does not respond to any I²C command and all DATA register bits are initialized to zeroes, therefore keeping the power blocks disabled. Once the V_{CC} rises above 4.8 V typ., the I²C interface becomes operative and the DATA registers can be configured by the main microprocessor.

2.17 PNG: input voltage minimum detection

When input voltage (V_{CC} pin) is lower than LPD (low power diagnostic) minimum thresholds, the PNG I²C bit is set to “1” and the FLT pin is set low. Refer to [Table 3](#) for threshold details.

2.18 ISW: inductor switching current limit

In order to allow low saturation current inductors to be used, the maximum DC-DC inductor switching current limit threshold can be set by means of one I²C bit per section (ISW). Two values are available: 2.5 A typ. (with ISW = 1) and 4 A typ. (with ISW = 0).

2.19 COMP: boost capacitor ESR

The DC-DC converter compensation loop can be optimized in order to work well with high or low ESR capacitors (on the V_{UP} pin). For this purpose, one I²C bit in the DATA4 register (COMP) can be set to “1” or “0”. It is recommended to reset this bit to “0” unless using high ESR capacitors.

2.20 OLF: overcurrent and short-circuit protection and diagnostic

In order to reduce the total power dissipation during an overload or a short-circuit condition, each section of the device is provided with a dynamic short-circuit protection. It is possible to set the short-circuit current protection either statically (simple current clamp) or dynamically by the corresponding PCL bit of the I²C DATA3 register. When the PCL (pulsed current limiting) bit is set to LOW, the overcurrent protection circuit works dynamically: as soon as an overload is detected, the output current is provided for T_{ON} time (90 ms or 180 ms typ., according to the corresponding TIMER bit programmed in the DATA3 register) and after that, the output is set in shutdown for a T_{OFF} time of typically 900 ms. Simultaneously, the corresponding diagnostic OLF I²C bit of the STATUS1 register is set to “1” and the FLT pin is set to low level. After this time has elapsed, the involved output is resumed for a time T_{ON} . At the end of T_{ON} , if the overload is still detected, the protection circuit cycles again through T_{OFF} and T_{ON} . At the end of a full T_{ON} in which no overload is detected, normal operation is resumed and the OLF diagnostic bit is reset to LOW after register reading is done. Typical $T_{ON} + T_{OFF}$ time is 990 ms (if TIMER=0) or 1080 ms (if TIMER=1) and is determined by an internal timer. This dynamic operation can greatly reduce the power dissipation in short-circuit condition, still ensuring excellent power-on startup in most conditions. However, there may be some cases in which a highly capacitive load on the output can cause a difficult startup when the dynamic protection is chosen. This can be solved by initiating any power startup in static mode (PCL=1) and then, switching to dynamic mode (PCL=0) after a chosen amount of time, depending on the output capacitance. Also in static mode, the diagnostic OLF bit goes to “1” (and the FLT pin is set to low) when the current clamp limit is reached and returns LOW when the overload condition is cleared and register reading is done.

After the overload condition is removed, normal operation can be resumed in two ways, according to the OLR I²C bit on the DATA4 register.

If OLR=1, all VSEL bits corresponding to the involved section are reset to “0” and the LNB section output (V_{OUT} pin) is disabled. To re-enable the output stage, the VSEL bits must be set again by the microprocessor and the OLF bit is reset to “0” after a register reading operation.

If OLR=0, the involved output is automatically re-enabled as soon as the overload condition is removed, and the OLF bit is reset to "0" after a register reading operation.

2.21 OTF: thermal protection and diagnostic

The LNBH26 is also protected against overheating: when the junction temperature exceeds 150 °C (typ.), the step-up converter and both liner regulators are shut off, the diagnostic OTF bit in the STATUS1 register is set to "1" and the FLT pin is set to low level. After the overtemperature condition is removed, normal operation can be resumed in two ways, according to the THERM I²C bit on the DATA4 register.

If THERM=1, all VSEL bits are reset to "0" and both LNB outputs (V_{OUT} pins) are disabled. To re-enable output stages, the VSEL bits must be set again by the microprocessor, while the OTF bit is reset to "0" after a register reading operation.

If THERM=0, outputs are automatically re-enabled as soon as the overtemperature condition is removed, while the OTF bit is reset to "0" after a register reading operation.

3 Pin configuration

Figure 5. Pin connections (top view)

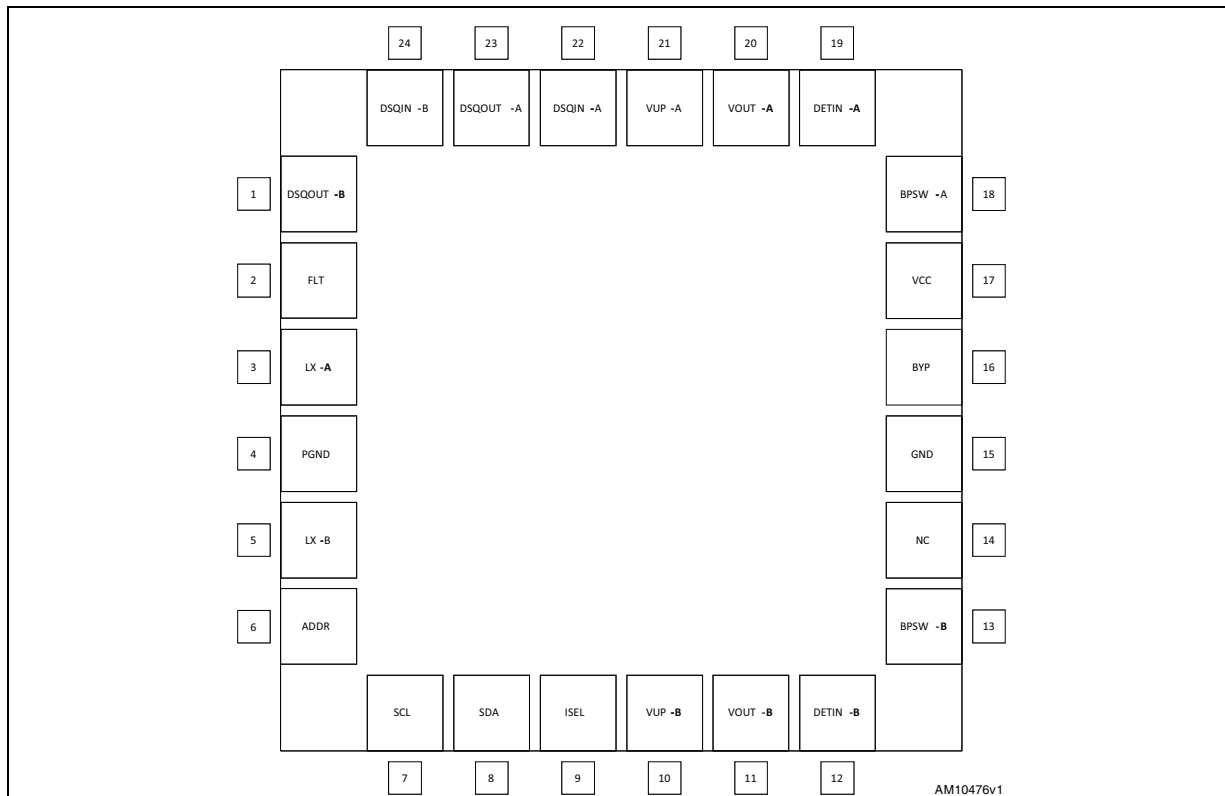

Table 2. Pin description

Pin	Symbol	Name	Pin function
1	DSQOUT-B	DiSEqC output	Open drain output of channel A tone detector to the main microcontroller for DiSEqC 2.0 data decoding. It is low when tone is detected on the DETIN-B input pin. Set to ground if not used.
2	FLT	FLT	Open drain output for IC fault conditions. It is set low in case of overload (OLF bit) or overheating status (OTF bit) or power not good (PNG bit) is detected. To be connected to pull-up resistor (5 V max.).
3	LX-A	N-Mos drain	Channel A, integrated N-channel Power MOSFET drain.
4	P-GND	Power ground	DC-DC converter power ground. To be connected directly to the exposed pad.
5	LX-B	N-Mos drain	Channel B, integrated N-channel Power MOSFET drain.
6	ADDR	Address setting	Two I ² C bus addresses available by setting the address pin level voltage. See Table 16 .
7	SCL	Serial clock	Clock from I ² C bus.
8	SDA	Serial data	Bi-directional data from/to I ² C bus.
9	ISEL	Current selection for both channel A and B	The resistor “RSEL” connected between ISEL and GND defines the linear regulator current limit threshold. Refer to Section 2.5 . Also see the ISET bit description in Table 9 . The RSEL resistor defines the same current limit both for channels A and B.

Table 2. Pin description (continued)

Pin	Symbol	Name	Pin function
10	V_{UP-B}	Channel B step-up voltage	Input of channel B linear post-regulator. The voltage on this pin is monitored by the internal channel B step-up controller to keep a minimum dropout across the linear pass transistor.
11	V_{OUT-B}	Channel B, LNB output port	Output of channel B integrated very low drop linear regulator. See Table 14 for voltage selection and description.
12	DETIN-B	Tone detector input	Channel B, 22 kHz tone decoder input, must be AC coupled to the DiSEqC 2.0 bus. Set to ground if not used.
13	BPSW-B	Switch control	To be connected to an external transistor to be used to bypass the channel B output RL filter needed in DiSEqC 2.x applications during the DiSEqC transmitting mode (see Section 5). Set to ground if not used. Open drain pin.
14	N.C.	Not internally connected	Not internally connected pin. Set floating if not used.
15	GND	Analog ground	Analog circuits ground. To be connected directly to the exposed pad.
16	BYP	Bypass capacitor	Needed for internal pre-regulator filtering. The BYP pin is intended only to connect an external ceramic capacitor. Any connection of this pin to external current or voltage sources may cause permanent damage to the device.
17	V_{CC}	Supply input	8 to 16 V IC DC-DC power supply.
18	BPSW-A	Switch control	To be connected to an external transistor to be used to bypass the channel A output RL filter needed in DiSEqC 2.x applications during the DiSEqC transmitting mode (see Section 5). Set to ground if not used. Open drain pin.
19	DETIN-A	Tone detector input	Channel A, 22 kHz tone decoder input, must be AC coupled to the DiSEqC 2.0 bus. Set to ground if not used.
20	V_{OUT-A}	Channel A, LNB output port	Output of channel A integrated very low drop linear regulator. See Table 14 for voltage selection and description.
21	V_{UP-A}	Channel A step-up voltage	Input of channel A linear post-regulator. The voltage on this pin is monitored by the internal channel A step-up controller to keep a minimum dropout across the linear pass transistor.
22	DSQIN-A	DSQIN for DiSEqC envelope input or external 22 kHz TTL input	It is intended for channel A 22 kHz tone control. It can be used as DiSEqC envelope input or external 22 kHz TTL input depending on the EXTM-A I ² C bit setting as follows: If EXTM-A=0, TEN-A=1: it accepts the DiSEqC envelope code from the main microcontroller. The LNBH26 uses this code to modulate the internally generated 22 kHz carrier. If EXTM-A=TEN-A=1: it accepts external 22 kHz logic signals which activate the 22 kHz tone output (refer to Section 2.2). Pull up high if the tone output is activated only by the TEN-A I ² C bit.
23	DSQOUT-A	DiSEqC output	Open drain output of channel A tone detector to the main microcontroller for DiSEqC 2.0 data decoding. It is low when tone is detected to the DETIN-A input pin. Set to ground if not used.

Table 2. Pin description (continued)

Pin	Symbol	Name	Pin function
24	DSQIN-B	DSQIN for DiSEqC envelope input Or external 22 kHz TTL input	It is intended for channel B 22 kHz tone control. It can be used as DiSEqC envelope input or external 22 kHz TTL input depending on the EXTM-B I ² C bit setting as follows: If EXTM-B=0, TEN-B=1: it accepts the DiSEqC envelope code from the main microcontroller. The LNBH26 uses this code to modulate the internally generated 22 kHz carrier. If EXTM-A=TEN-A=1: it accepts external 22 kHz logic signals which activate the 22 kHz tone output (refer to Section 2.2). Pull up high if the tone output is activated only by the TEN-B I ² C bit.
Epad	Epad	Exposed pad	To be connected with power grounds and to the ground layer through vias to dissipate the heat.

4 Maximum ratings

Table 3. Absolute maximum ratings

Symbol	Parameter	Value	Unit
V_{CC}	DC power supply input voltage pins	-0.3 to 20	V
V_{UP}	DC input voltage	-0.3 to 40	V
I_{OUT}	Output current	Internally limited	mA
V_{OUT}	DC output pin voltage	-0.3 to 40	V
V_I	Logic input pin voltage (SDA, SCL, DSQIN, ADDR pins)	-0.3 to 7	V
V_O	Logic output pin voltage (FLT, DSQOUT)	-0.3 to 7	V
V_{BPSW}	BPSW pin voltage	-0.3 to 40	V
V_{DETIN}	Detector input signal amplitude	-0.6 to 2	V
I_O	Logic output pin current (FLT, DSQOUT, BPSW)	10	mA
LX	LX input voltage	-0.3 to 30	V
V_{BYP}	Internal reference pin voltage	-0.3 to 4.6	V
ISEL	Current selection pin voltage	-0.3 to 3.5	V
T_{STG}	Storage temperature range	-50 to 150	°C
T_J	Operating junction temperature range	-25 to 125	°C
ESD	ESD rating with human body model (HBM) for all pins, except power output pins	2	kV
	ESD rating with human body model (HBM) for power output pins	4	

Table 4. Thermal data

Symbol	Parameter	Value	Unit
R_{thJC}	Thermal resistance junction-case	2	°C/W
R_{thJA}	Thermal resistance junction-ambient with device soldered on 2s2p 4-layer PCB provided with thermal vias below exposed pad.	40	°C/W

Note: Absolute maximum ratings are those values beyond which damage to the device may occur. These are stress ratings only and functional operation of the device at these conditions is not implied. Exposure to absolute-maximum-rated conditions for extended periods may affect device reliability. All voltage values are with respect to network ground terminal.

5 Typical application circuits

Figure 6. DiSEqC 1.x application circuit

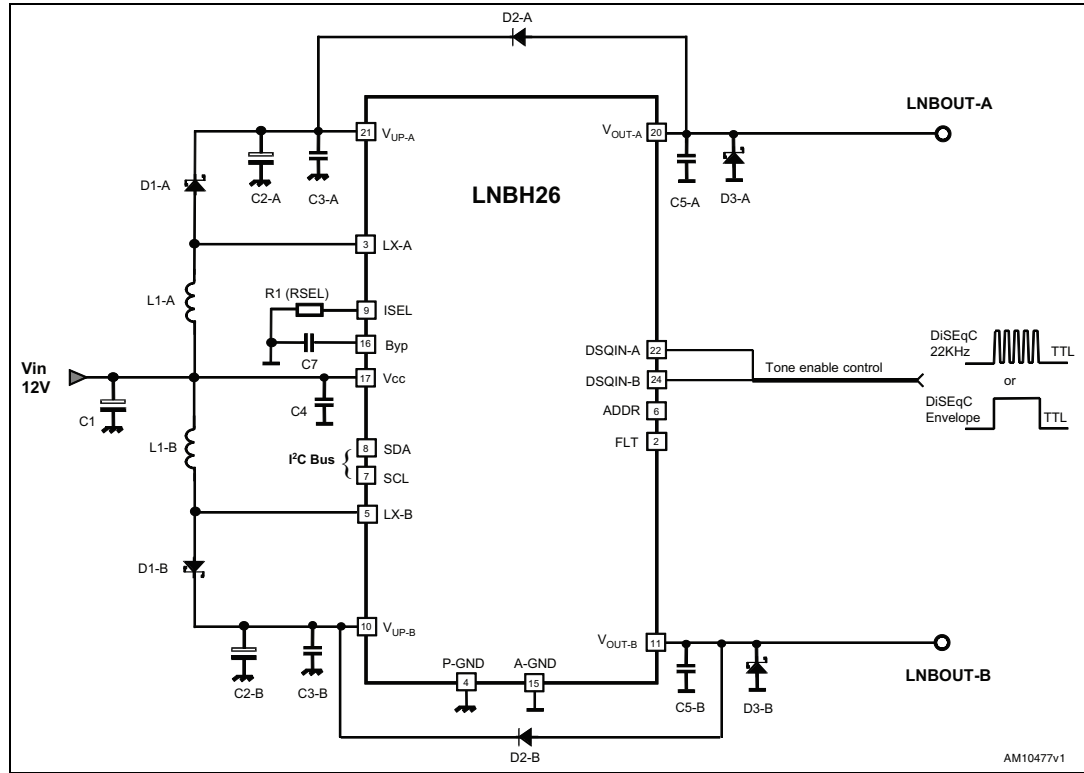

Table 5. DiSEqC 1.x bill of material (valid for A and B channels except for C1, C4, C7 and R1)

Component	Notes
R1 (RSEL)	SMD resistor. Refer to Table 13 and ISEL pin description in Table 2
C1, C2	> 25 V electrolytic capacitor, 100 μ F is suitable
C3	From 470 nF to 2.2 μ F ceramic capacitor. Higher values allow lower DC-DC noise.
C5	From 100 nF to 220 nF ceramic capacitor. Higher values allow lower DC-DC noise.
C4, C7	220 nF ceramic capacitors
D1	STPS130A or similar schottky diode
D3	BAT54, BAT43, 1N5818, or any low power schottky diode with $I_F (AV) > 0.2$ A, $V_{RRM} > 25$ V, $V_F < 0.5$ V. To be placed as close as possible to V_{OUT} pin
D2	1N4001-07, S1A-S1M, or any similar general purpose rectifier
L1	10 μ H inductor with $I_{sat} > I_{peak}$ where I_{peak} is the boost converter peak current

Figure 7. DiSEqC 2.x application circuit

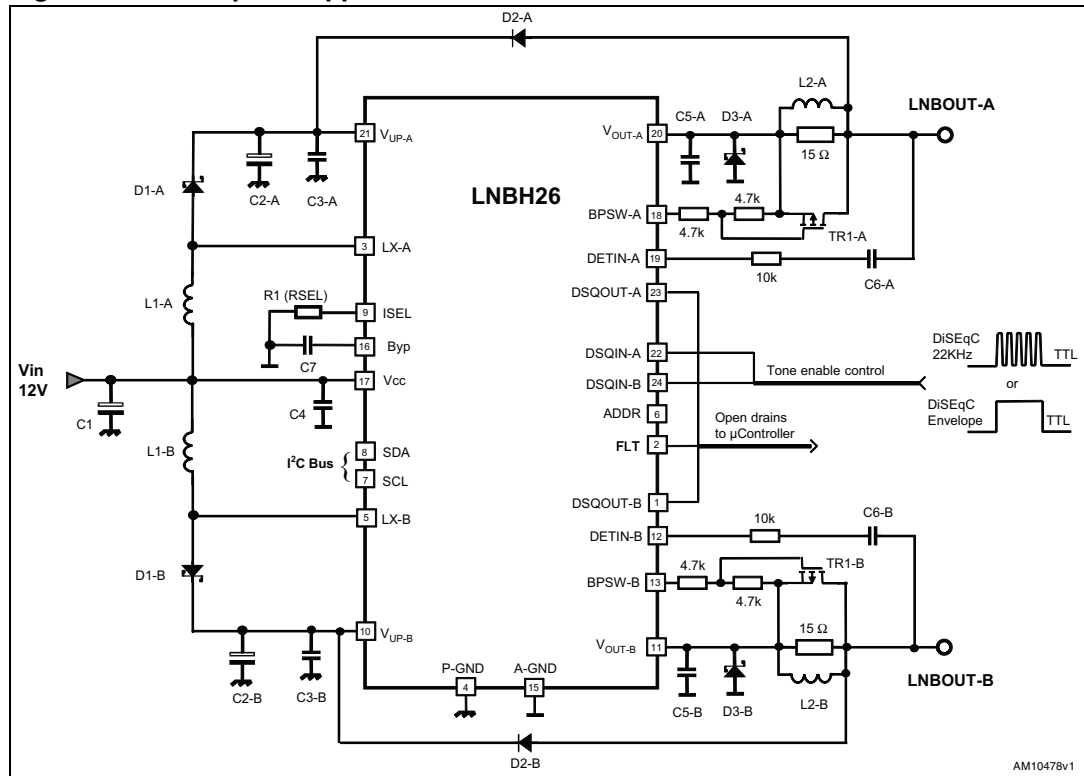

Table 6. DiSEqC 2.x bill of material (valid for A and B channels except for C1, C4, C7 and R1)

Component	Notes
R1 (RSEL)	SMD resistors. Refer to Table 13 and ISEL pin description in Table 2
C1, C2	> 25 V electrolytic capacitor, 100 μF is suitable
C3	From 470 nF to 2.2 μF ceramic capacitor. Higher values allow lower DC-DC noise.
C5	From 100 nF to 220 nF ceramic capacitor. Higher values allow lower DC-DC noise.
C4, C7	220 nF ceramic capacitors
C6	10 nF ceramic capacitors
D1	STPS130A or similar schottky diode
D3	BAT54, BAT43, 1N5818, or any low power schottky diode with $I_F (AV) > 0.2 A$, $V_{RRM} > 25 V$, $V_F < 0.5 V$. To be placed as close as possible to V_{OUT} pin
D2	1N4001-07, S1A-S1M, or any similar general purpose rectifier
L1	10 μH inductor with $I_{sat} > I_{peak}$ where I_{peak} is the boost converter peak current
L2	220 μH inductor
TR1	2STR2160 or 2STF2340 or any small power PNP with $I_C > 250 mA$, $V_{CE} > 30 V$, can be used. Also any small power PMOS with $I_D > 250 mA$, $R_{DS(ON)} < 0.5\Omega$, $V_{DS} > 20 V$, can be used.

6 I²C bus interface

Data transmission from the main microprocessor to the LNBH26 and vice versa takes place through the 2-wire I²C bus interface, consisting of the 2-line SDA and SCL (pull-up resistors to positive supply voltage must be externally connected).

6.1 Data validity

As shown in [Figure 8](#), the data on the SDA line must be stable during the high semi-period of the clock. The HIGH and LOW state of the data line can only change when the clock signal on the SCL line is LOW.

6.2 Start and stop condition

As shown in [Figure 9](#), a start condition is a HIGH to LOW transition of the SDA line while SCL is HIGH. The stop condition is a LOW to HIGH transition of the SDA line while SCL is HIGH. A STOP condition must be sent before each START condition.

6.3 Byte format

Every byte transferred to the SDA line must contain 8 bits. Each byte must be followed by an acknowledge bit. The MSB is transferred first.

6.4 Acknowledge

The master (microprocessor) puts a resistive HIGH level on the SDA line during the acknowledge clock pulse (see [Figure 10](#)). The peripheral (LNBH26) which acknowledges must pull down (LOW) the SDA line during the acknowledge clock pulse, so that the SDA line is stable LOW during this clock pulse. The peripheral which has been addressed must generate acknowledge after the reception of each byte, otherwise the SDA line remains at the HIGH level during the ninth clock pulse time. In this case the master transmitter can generate the STOP information in order to abort the transfer. The LNBH26 does not generate acknowledge if the V_{CC} supply is below the undervoltage lockout threshold (4.7 V typ.).

6.5 Transmission without acknowledge

If detection of the acknowledge of the LNBH26 is not required, the microprocessor can use a simpler transmission: it simply waits one clock without checking the slave acknowledging, and sends the new data. This approach is of course less protected from misworking and decreases noise immunity.

Figure 8. Data validity on the I²C bus

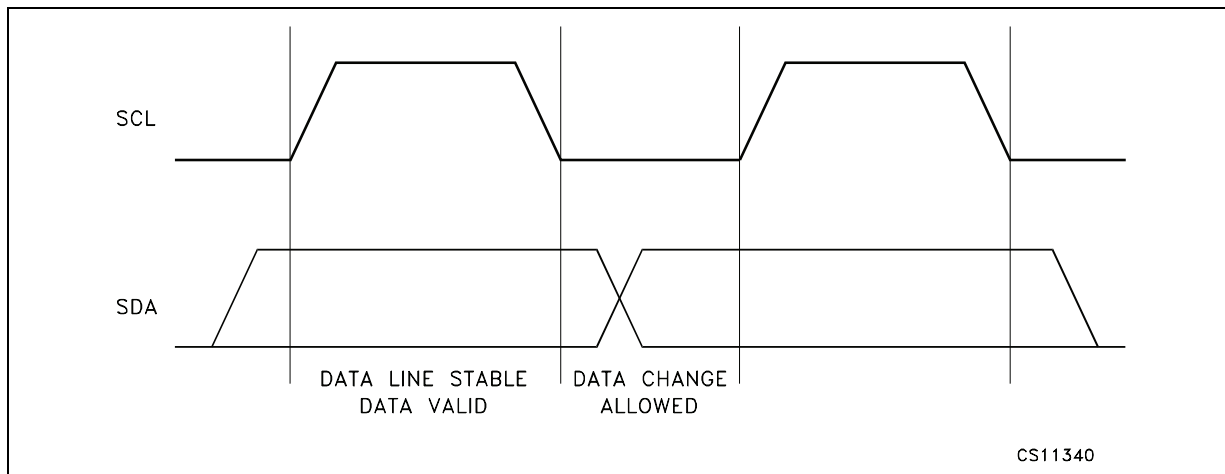

Figure 9. Timing diagram of I²C bus

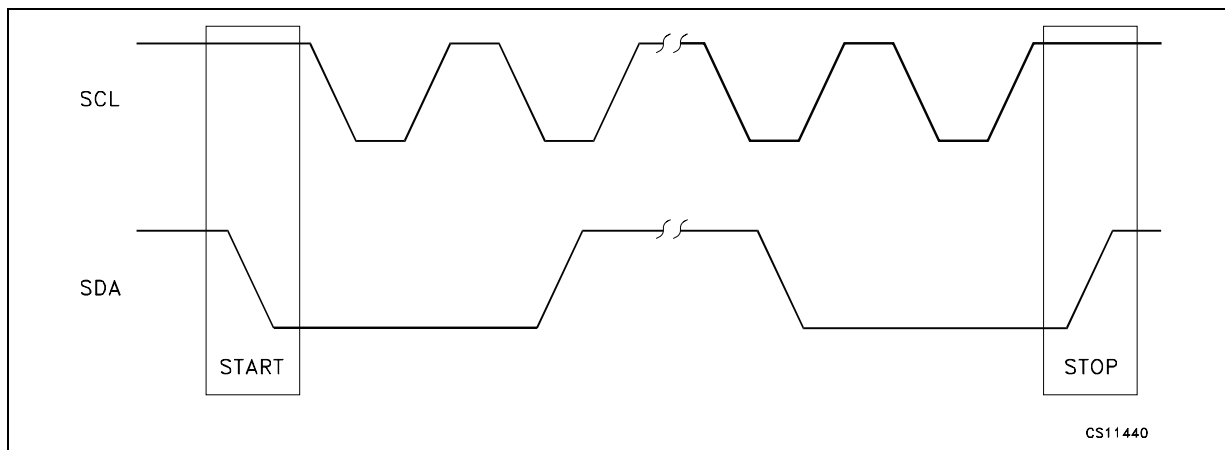
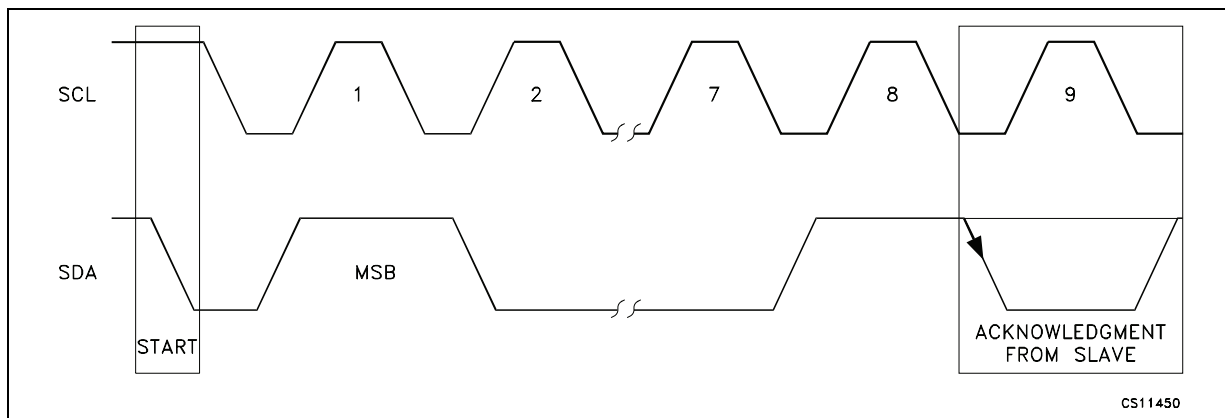

Figure 10. Acknowledge on the I²C bus



7 I²C interface protocol

7.1 Write mode transmission

The LNBH26 interface protocol is made up of:

- a start condition (S)
- a chip address byte with the LSB bit R/W = 0
- a register address (internal address of the first register to be accessed)
- a sequence of data (byte to write in the addressed internal register + acknowledge)
- the following bytes, if any, to be written in successive internal registers
- a stop condition (P). The transfer lasts until a stop bit is encountered
- the LNBH25, as slave, acknowledges every byte transfer.

Figure 11. Example of writing procedure starting with first data address 0x2 (a)

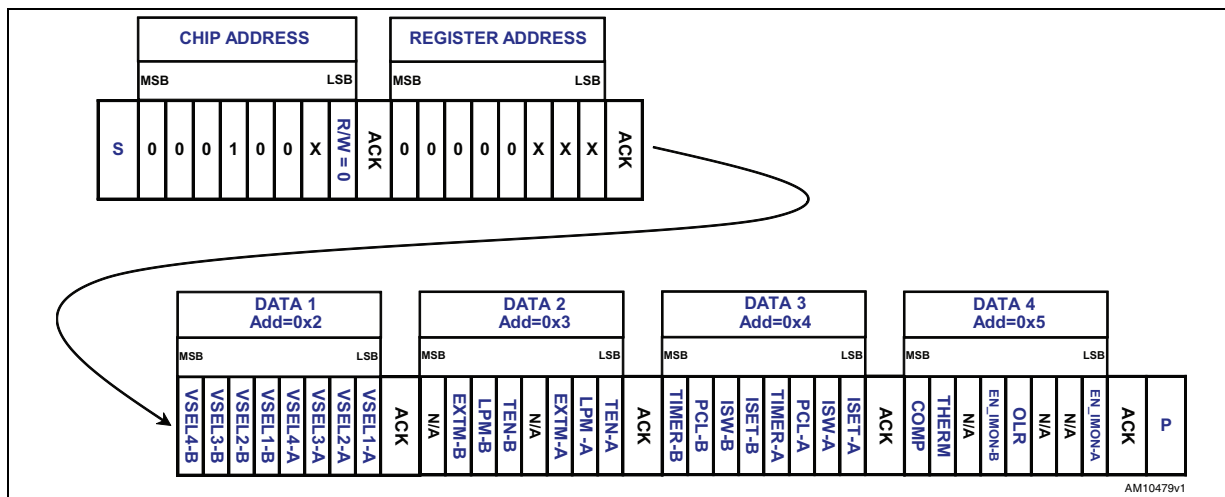

ACK = Acknowledge

S = Start

P = Stop

R/W = 1/0, Read/Write bit

X = 0/1, set the values to select the CHIP address (see [Table 16](#) for pin selection) and to select the REGISTER address (see [Table 7](#) to [Table 12](#)).

a. The writing procedure can start from any register address by simply setting the X values in the register address byte (after the chip address). It can be also stopped by the master by sending a stop condition after any acknowledge bit.

7.2 Read mode transmission

In read mode the bytes sequence must be as follows:

- a start condition (S)
- a chip address byte with the LSB bit R/W=0
- the register address byte of the internal first register to be accessed
- a stop condition (P)
- a new master transmission with the chip address byte and the LSB bit R/W=1
- after the acknowledge the LNBH26 starts to send the addressed register content. As long as the master keeps the acknowledge LOW, the LNBH26 transmits the next address register byte content.
- the transmission is terminated when the master sets the acknowledge HIGH with a following stop bit.

Figure 12. Example of reading procedure starting with first status address 0X0 ^(b)

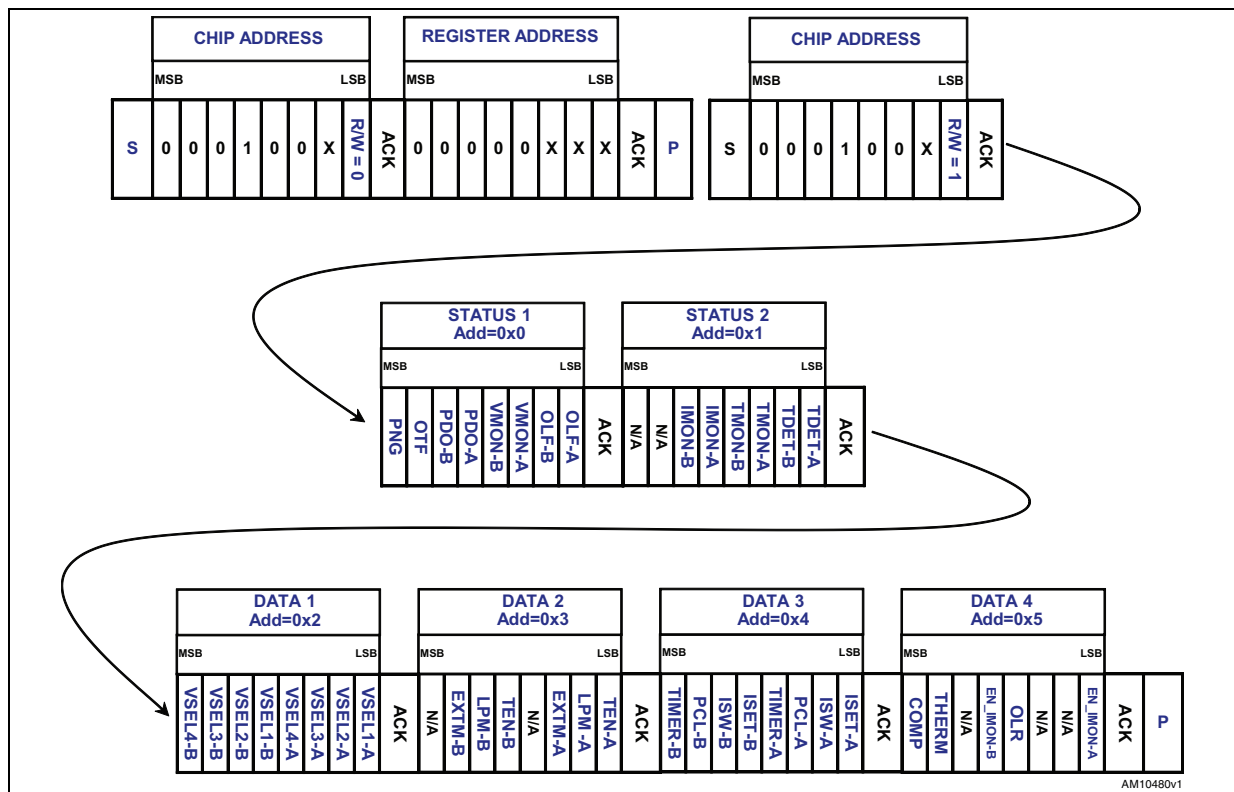

ACK = Acknowledge

S = Start

P = Stop

R/W = 1/0, Read/Write bit

X = 0/1, set the values to select the CHIP address (see [Table 16](#) for pin selection) and to select the REGISTER address (see [Table 7](#) to [Table 12](#)).

b. The reading procedure can start from any register address (Status 1, 2 or Data1..4) by simply setting the X values in the register address byte (after the first chip address in the above figure). It can be also stopped by the master by sending a stop condition after any acknowledge bit.

7.3 Data registers

The DATA 1..4 registers can be addressed both in write and read mode. In read mode they return the last writing byte status received in the previous write transmission.

The following tables provide the register address values of Data 1..4 and a function description of each bit.

Table 7. DATA 1 (Read/Write register. Register address = 0X2)

Bit	Name	CH	Value	Description
Bit 0 (LSB)	VSEL1-A	A	0/1	Channel A Output voltage selection bits. (Refer to Table 14)
Bit 1	VSEL2-A		0/1	
Bit 2	VSEL3-A		0/1	
Bit 3	VSEL4-A		0/1	
Bit 4	VSEL1-B	B	0/1	Channel B Output voltage selection bits. (Refer to Table 14)
Bit 5	VSEL2-B		0/1	
Bit 6	VSEL3-B		0/1	
Bit 7 (MSB)	VSEL4-B		0/1	

N/A = Reserved bit.

All bits reset to “0” at power-on.

Table 8. DATA 2 (Read/Write register. Register address = 0X3)

Bit	Name	CH	Value	Description
Bit 0 (LSB)	TEN-A	A	1	22 kHz tone enabled. Tone output controlled by the DSQIN pin
			0	22 kHz tone output disabled
Bit 1	LPM-A		1	Low power mode activated (used only with 22 kHz tone output disabled)
			0	Low power mode deactivated (keep always LPM=0 during 22 kHz tone transmission)
Bit 2	EXTM-A		1	DSQIN input pin is set to receive external 22 kHz TTL signal source
			0	DSQIN input pin is set to receive external DiSEqC envelope TTL signal
Bit 3	N/A		0	Reserved. Keep to "0"
Bit 4	TEN-B		B	1
		0		22 kHz tone output disabled
Bit 5	LPM-B	1		Low power mode activated (used only with 22 kHz tone output disabled)
		0		Low power mode deactivated (keep always LPM=0 during 22 kHz tone transmission)
Bit 6	EXTM-B	1		DSQIN input pin is set to receive external 22 kHz TTL signal source
		0		DSQIN input pin is set to receive external DiSEqC envelope TTL signal
Bit 7 (MSB)	N/A	0		Reserved. Keep to "0"

N/A = Reserved bit.

All bits reset to 0 at power-on.

Table 9. DATA 3 (Read/Write register. Register address = 0X4)

Bit	Name	CH	Value	Description
Bit 0 (LSB)	ISET-A	A	1	Current limit of LNB output (Vout pin) set to lower current range: Refer to Section 2.5 in application information section.
			0	Current limit of LNB output (Vout pin) set to default range: Refer to Section 2.5 in application information section.
Bit 1	ISW-A		1	DC-DC, inductor switching current limit set to 2.5 A typ.
			0	DC-DC, inductor switching current limit set to 4 A typ.
Bit 2	PCL-A		1	Pulsed (Dynamic) LNB output current limiting is deactivated
			0	Pulsed (Dynamic) LNB output current limiting is activated
Bit 3	TIMER-A		1	Pulsed (Dynamic) LNB output current T _{ON} time set to 180 ms typ.
			0	Pulsed (Dynamic) LNB output current T _{ON} time set to 90 ms typ.
Bit 4	ISET-B	B	1	Current limit of LNB output (V _{OUT} pin) set to lower current range: Refer to Section 2.5 in the application information section.
			0	Current limit of LNB output (V _{OUT} pin) set to default range: Refer to Section 2.5 in the application information section.
Bit 5	ISW-B		1	DC-DC, inductor switching current limit set to 2.5 A typ.
			0	DC-DC, inductor switching current limit set to 4 A typ.
Bit 6	PCL-B		1	Pulsed (Dynamic) LNB output current limiting is deactivated
			0	Pulsed (Dynamic) LNB output current limiting is activated
Bit 7 (MSB)	TIMER-B		1	Pulsed (Dynamic) LNB output current T _{ON} time set to 180 ms typ.
			0	Pulsed (Dynamic) LNB output current T _{ON} time set to 90 ms typ.

N/A = Reserved bit.

All bits reset to 0 at power-on.

Table 10. DATA 4 (Read/Write register. Register address = 0X5)

Bit	Name	CH	Value	Description
Bit 0 (LSB)	EN_IMON-A	A	1	IMON diagnostic function is enabled. (V_{OUT} is set to 21 V typ.)
			0	IMON diagnostic function is disabled. Keep always at "0" if IMON is not used.
Bit 1	N/A		0	Reserved. Keep to "0"
Bit 2	N/A		0	Reserved. Keep to "0"
Bit 3	OLR	A/B	1	In the case of overload protection activation (OLF=1), all VSEL bits are reset to "0" and LNB relevant output (V_{OUT} pin) is disabled. The VSEL bits must be set again by the master after the overcurrent condition is removed (OLF=0).
			0	In the case of overload protection activation (OLF=1) the LNB output (V_{OUT} pin) is automatically enabled as soon as the overload condition is removed (OLF=0) with the previous VSEL bit setting.
Bit 4	EN_IMON-B	B	1	IMON diagnostic function is enabled
			0	IMON diagnostic function is disabled. Keep always at "0" if IMON is not used.
Bit 5	N/A		0	Reserved. Keep to "0"
Bit 6	THERM	A/B	1	If thermal protection is activated (OTF=1), all VSEL bits are reset to "0" and LNB output (V_{OUT} pin) is disabled (both section A & B). The VSEL bits must be set again by the master after the overtemperature condition is removed (OTF=0).
			0	In the case of thermal protection activation (OTF=1) the LNB output (V_{OUT} pin) is automatically enabled as soon as the overtemperature condition is removed (OTF=0) with the previous VSEL bit setting.
Bit 7 (MSB)	COMP		1	DC-DC converter compensation set to use HIGH E.S.R. capacitors (V_{UP} pin)
			0	DC-DC converter compensation set to use LOW E.S.R. capacitors (V_{UP} pin)

7.4 Status registers

The STATUS 1, 2 registers can be addressed only in read mode and provide the diagnostic functions described in the following tables.

Table 11. STATUS 1 (Read register. Register address = 0X0)

Bit	Name	CH	Value	Description
Bit 0 (LSB)	OLF-A	A	1	V _{OUT} pin overload protection has been triggered (I _{OUT} > I _{MAX}). Refer to Table 9 for the overload operation settings (ISET, PCL, TIMER bits).
			0	No overload protection has been triggered to V _{OUT} pin (I _{OUT} < I _{MAX}).
Bit 1	OLF-B	B	1	V _{OUT} pin overload protection has been triggered (I _{OUT} > I _{MAX}). Refer to Table 9 for the overload operation settings (ISET, PCL, TIMER bits).
			0	No overload protection has been triggered to V _{OUT} pin (I _{OUT} < I _{MAX}).
Bit 2	VMON-A	A	1	Output voltage (V _{OUT} pin) lower than VMON specification thresholds. Refer to Table 17 .
			0	Output voltage (V _{OUT} pin) is within the VMON specifications.
Bit 3	VMON-B	B	1	Output voltage (V _{OUT} pin) lower than VMON specification thresholds. Refer to Table 17 .
			0	Output voltage (V _{OUT} pin) is within the VMON specifications.
Bit 4	PDO-A	A	1	Overcurrent detected on output pull-down stage for a time longer than the deglitch period. This may happen due to an external voltage source present on the LNB output (V _{OUT} pin).
			0	No overcurrent detected on output pull-down stage.
Bit 5	PDO-B	B	1	Overcurrent detected on output pull-down stage for a time longer than the deglitch period. This may happen due to an external voltage source present on the LNB output (V _{OUT} pin).
			0	No overcurrent detected on output pull-down stage.
Bit 6	OTF	A/B	1	Junction overtemperature is detected, T _J > 150 °C (typ.). See also the THERM bit setting in Table 10 .
			0	Junction overtemperature not detected, T _J < 135 °C (typ.). T _J is below thermal protection threshold.
Bit 7 (MSB)	PNG	A/B	1	Input voltage (V _{CC} pin) lower than LPD minimum thresholds. Refer to Table 13 .
			0	Input voltage (V _{CC} pin) higher than LPD thresholds. Refer to Table 13 .

N/A = Reserved bit.

All bits reset to 0 at power-on.

Table 12. STATUS 2 (Read register. Register address = 0X1)

Bit	Name	CH	Value	Description
Bit 0 (LSB)	TDET-A	A	1	22 kHz tone presence is detected on the DETIN pin
			0	No 22 kHz tone is detected on the DETIN pin
Bit 1	TDET-B	B	1	22 kHz tone presence is detected on the DETIN pin
			0	No 22 kHz tone is detected on the DETIN pin
Bit 2	TMON-A	A	1	22 kHz tone present on the DETIN pin is out of TMON specification thresholds. That is: the tone frequency or the A_{TONE} (tone amplitude) are out of the thresholds guaranteed in Table 19 .
			0	22 kHz tone present on the DETIN pin is within TMON specification thresholds. Refer to Table 19 .
Bit 3	TMON-B	B	1	22 kHz tone present on the DETIN pin is out of TMON specification thresholds. That is: the tone frequency or the A_{TONE} (tone amplitude) are out of the thresholds guaranteed in Table 19 .
			0	22 kHz tone present on DETIN pin is within TMON specification thresholds. Refer to Table 19 .
Bit 4	IMON-A	A	1	Output current (from V_{OUT} pin) is lower than IMON specification thresholds. Refer to Table 18 .
			0	Output current (from V_{OUT} pin) is higher than IMON specifications. Refer to Table 18 .
Bit 5	IMON-B	B	1	Output current (from V_{OUT} pin) is lower than IMON specification thresholds. Refer to Table 18 .
			0	Output current (from V_{OUT} pin) is higher than IMON specifications. Refer to Table 18 .
Bit 6	N/A		-	Reserved
Bit 7 (MSB)	N/A		-	Reserved

N/A = Reserved bit.

All bits reset to 0 at power-on.

8 Electrical characteristics

Refer to [Section 5](#), T_J from 0 to 85 °C, all DATA 1..4 register bits set to 0 except VSEL1 = 1, RSEL = 11 kΩ, DSQIN = LOW, V_{IN} = 12 V, I_{OUT} = 50 mA, unless otherwise stated. Typical values are referred to T_J = 25 °C. V_{OUT} = V_{OUT} pin voltage. See software description section for I²C access to the system register ([Section 6](#) and [Section 7](#)).

Table 13. Electrical characteristics of section A/B

Symbol	Parameter	Test conditions	Min.	Typ.	Max.	Unit
V_{IN}	Supply voltage ⁽¹⁾		8	12	16	V
I_{IN}	Supply current	Both sections A and B enabled, I_{OUT} = 0 mA		12		mA
		22 kHz tone enabled (TEN-A/B = 1, DSQIN-A/B = High), I_{OUT} = 0 mA		19		
		Both sections A and B set in standby: VSEL1=VSEL2=VSEL3=VSEL4=0		2		
V_{OUT}	Output voltage total accuracy	Valid at any V_{OUT} selected level	-3.5		+3.5	%
V_{OUT}	Line regulation	V_{IN} = 8 to 16 V			40	mV
V_{OUT}	Load regulation	I_{OUT} from 50 to 750 mA		100		
I_{MAX}	Output current limiting thresholds	RSEL = 11 kΩ, ISET = 0	750		1100	mA
		RSEL = 15 kΩ, ISET = 0	500		750	
		RSEL = 20 kΩ, ISET = 0	350		550	
I_{MAX}	Output current limiting thresholds	RSEL = 11 kΩ, ISET = 1		400		mA
		RSEL = 15 kΩ, ISET = 1		280		
		RSEL = 20 kΩ, ISET = 1		200		
I_{SC}	Output short-circuit current	RSEL = 11 kΩ, ISET = 0		500		mA
SS	Soft-start time	V_{OUT} from 0 to 13 V		4		ms
SS	Soft-start time	V_{OUT} from 0 to 18 V		6		ms
T13-18	Soft transition rise time	V_{OUT} from 13 V to 18 V		1.5		ms
T18-13	Soft transition fall time	V_{OUT} from 18 V to 13 V		1.5		ms
T_{OFF}	Dynamic overload protection OFF time	PCL = 0, output shorted		900		ms
T_{ON}	Dynamic overload protection ON time	PCL = TIMER = 0, output shorted		$T_{OFF}/10$		
		PCL = 0, TIMER = 1, output shorted		$T_{OFF}/5$		
A_{TONE}	Tone amplitude	DSQIN=High, EXTM=0, TEN=1 I_{OUT} from 0 to 750 mA C_{BUS} from 0 to 750 nF	0.55	0.675	0.8	V_{PP}

Table 13. Electrical characteristics of section A/B (continued)

Symbol	Parameter	Test conditions	Min.	Typ.	Max.	Unit
F _{TONE}	Tone frequency	DSQIN=High, EXTM=0, TEN=1	20	22	24	kHz
D _{TONE}	Tone duty cycle		43	50	57	%
tr, tf	Tone rise or fall time ⁽²⁾		5	8	15	μs
Eff _{DC/DC}	DC-DC converter efficiency	I _{OUT} = 500 mA		93		%
F _{SW}	DC-DC converter switching frequency			440		kHz
UVLO	Undervoltage lockout thresholds	UVLO threshold rising		4.8		V
		UVLO threshold falling		4.7		
V _{LP}	Low power diagnostic (LPD) thresholds	V _{LP} threshold rising		7.2		V
		V _{LP} threshold falling		6.7		
V _{IL}	DSQIN, pin logic low				0.8	V
V _{IH}	DSQIN, pin logic high		2			V
I _{IH}	DSQIN, pin input current	V _{IH} = 5 V		15		μA
F _{DETIN}	Tone detector frequency capture range	0.4 V _{PP} sine wave ⁽³⁾	19	22	25	kHz
V _{DETIN}	Tone detector input amplitude	Sine wave signal, 22 kHz	0.3		1.5	V _{PP}
Z _{DETIN}	Tone detector input impedance			150		kΩ
V _{OL}	DSQOUT, FLT pins logic LOW	DETIN tone present, I _{OL} = 2 mA		0.3	0.5	V
V _{OL_BPSW}	BPSW pin low voltage	I _{OL_BPSW} = 5 mA DSQIN = high, EXTM = 0, TEN = 1		0.7		V
I _{OZ}	DSQOUT, FLT pins leakage current	DETIN tone absent, V _{OH} = 6 V			10	μA
I _{OBK}	Output backward current	All VSELx = 0, V _{OBK} = 30 V		-3	-6	mA
I _{SINK}	Output low-side sink current	V _{OUT} forced at V _{OUT_nom} +0.1 V		70		mA
I _{SINK_TIME-OUT}	Low-side sink current time-out	V _{OUT} forced at V _{OUT_nom} +0.1 V. PDO I ² C bit is set to 1 after this time is elapsed.		10		ms
I _{REV}	Max. reverse current	V _{OUT} forced at V _{OUT_nom} +0.1 V, after PDO bit is set to 1 (I _{SINK_TIME-OUT} elapsed).		2		mA
T _{SHDN}	Thermal shutdown threshold			150		°C
ΔT _{SHDN}	Thermal shutdown hysteresis			15		°C

1. In applications where (V_{CC} - V_{OUT}) > 1.3 V, the increased power dissipation inside the integrated LDO must be taken into account in the application thermal management design.
2. Guaranteed by design.
3. Frequency range in which the DETIN function is guaranteed. The V_{pp} level is intended on the LNB bus (before the C6 capacitor. See typical application circuit for DiSEqC 2.x) I_{OUT} from 0 to 750 mA, C_{BUS} from 0 to 750 nF.

8.1 Output voltage selection

Each LNBH26 channel is provided with 15 output voltage levels (7 levels for 13 V range when VSEL4-A/B=0 and 8 levels for 18 V range when VSEL4-A/B=1) which can be selected through the register Data1. [Table 14](#) shows the output voltage values corresponding to VSELx bit combinations both for channel A and B. If all VSELx are set to “0” the device is set in standby mode and the VOUT-A/B is disabled.

Table 14. Output voltage selection table (Data1 register, write mode) ⁽¹⁾

VSEL4-A/B	VSEL3-A/B	VSEL2-A/B	VSEL1-A/B	V _{OUT} min.	V _{OUT} -A/B pin voltage	V _{OUT} max.	Function
0	0	0	0		0		V _{OUT} -A/B disabled. LNBH26 set in standby mode
0	0	0	1	12.545	13.000	13.455	
0	0	1	0	12.867	13.333	13.800	
0	0	1	1	13.188	13.667	14.145	
0	1	0	0	13.51	14.000	14.490	
0	1	0	1	13.832	14.333	14.835	
0	1	1	0	14.153	14.667	15.180	
0	1	1	1	14.475	15.000	15.525	
1	0	0	0	17.515	18.150	18.785	
1	0	0	1	17.836	18.483	19.130	
1	0	1	0	18.158	18.817	19.475	
1	0	1	1	18.48	19.150	19.820	
1	1	0	0	18.801	19.483	20.165	
1	1	0	1	19.123	19.817	20.510	
1	1	1	0	19.445	20.150	20.855	
1	1	1	1	19.766	20.483	21.200	

1. T_J from 0 to 85 °C, V_I = 12 V.

T_J from 0 to 85 °C, V_I = 12 V.

Table 15. I²C electrical characteristics

Symbol	Parameter	Test conditions	Min.	Typ.	Max.	Unit
V _{IL}	Low level input voltage	SDA, SCL			0.8	V
V _{IH}	High level input voltage	SDA, SCL	2			V
I _{IN}	Input current	SDA, SCL, V _{IN} = 0.4 to 4.5 V	-10		10	μA
V _{OL}	Low level output voltage ⁽¹⁾	SDA (open drain), I _{OL} = 6 mA			0.6	V
F _{MAX}	Maximum clock frequency	SCL	400			kHz

1. Guaranteed by design.

T_J from 0 to 85 °C, $V_I = 12$ V.

Table 16. Address pin characteristics

Symbol	Parameter	Test condition	Min.	Typ.	Max.	Unit
V_{ADDR-1}	“0001000(R/W)” address pin voltage range	R/W bit determines the transmission mode: read (R/W=1) write (R/W=0)	0		0.8	V
V_{ADDR-2}	“0001001(R/W)” address pin voltage range	R/W bit determines the transmission mode: read (R/W=1) write (R/W=0)	2		5	V

Refer to [Section 5](#), T_J from 0 to 85 °C, All DATA 1..4 register bits set to “0”, RSEL = 11 k Ω , DSQIN = LOW, $V_{IN} = 12$ V, $I_{OUT} = 50$ mA, unless otherwise stated. Typical values are referred to $T_J = 25$ °C. $V_{OUT} = V_{OUT}$ pin voltage. See software description section for I²C access to the system register.

Table 17. Output voltage diagnostic (VMON-A/B bits, STATUS 1 register) characteristics

Symbol	Parameter	Test condition	Min.	Typ.	Max.	Unit
V_{TH-L}	Diagnostic low threshold at $V_{OUT} = 13.0$ V	VSEL1 = 1, VSEL2 = VSEL3 = VSEL4 = 0	80	90	95	%
V_{TH-L}	Diagnostic low threshold at $V_{OUT} = 18.15$ V	VSEL4=1, VSEL1 = VSEL2 = VSEL3 = 0	80	90	95	%

Note: If the output voltage is lower than the min. value the VMON I²C bit is set to 1.

If VMON=0 then $V_{OUT} > 80\%$ of V_{OUT} (typ.).

If VMON=1 then $V_{OUT} < 95\%$ of V_{OUT} (typ.).

Refer to [Section 5](#), T_J from 0 to 85 °C, RSEL = 11 k Ω , DSQIN = LOW, $V_{IN} = 12$ V, unless otherwise stated. Typical values are referred to $T_J = 25$ °C. $V_{OUT} = V_{OUT}$ pin voltage. See software description section for I²C access to the system register.

Table 18. Output current diagnostic (IMON-A/B bit, STATUS 2 register) characteristics

Symbol	Parameter	Test condition	Min.	Typ.	Max.	Unit
I_{TH}	Minimum current diagnostic threshold	EN_IMON = 1 (V_{OUT} is set to 21 V typ.)	5	12	20	mA

Note: If the output current is lower than the min. threshold limit, the IMON I²C bit is set to 1. If the output current is higher than the max. threshold limit, the IMON I²C bit is set to 0.

Refer to [Section 5](#), T_J from 0 to 85 °C, All DATA 1..4 register bits set to “0” except VSEL1 = 1, TEN=1, RSEL = 11 kΩ, DSQIN = HIGH, $V_{IN} = 12\text{ V}$, $I_{OUT} = 50\text{ mA}$, unless otherwise stated. Typical values are referred to $T_J = 25\text{ °C}$. $V_{OUT} = V_{OUT}$ pin voltage. See software description section for I²C access to the system register.

Table 19. 22 kHz tone diagnostic (TMON-A/B bit, STATUS 2 register) characteristics

Symbol	Parameter	Test condition	Min.	Typ.	Max.	Unit
A _{TH-L}	Amplitude diagnostic low threshold	DETIN pin AC coupled	200	300	400	mV
A _{TH-H}	Amplitude diagnostic high threshold	DETIN pin AC coupled	900	1100	1200	mV
F _{TH-L}	Frequency diagnostic low thresholds	DETIN pin AC coupled	13	16.5	20	kHz
F _{TH-H}	Frequency diagnostic high thresholds	DETIN pin AC coupled	24	29.5	38	kHz

Note: If the 22 kHz tone parameters are lower or higher than the above limits, the TMON I²C bit is set to “1”.

9 Package mechanical data

In order to meet environmental requirements, ST offers these devices in different grades of ECOPACK® packages, depending on their level of environmental compliance. ECOPACK specifications, grade definitions and product status are available at: www.st.com. ECOPACK is an ST trademark.

Table 20. QFN24L (4 x 4 mm) mechanical data

Dim.	(mm.)		
	Min.	Typ.	Max.
A	0.80	0.90	1.00
A1	0.00	0.02	0.05
b	0.18	0.25	0.30
D	3.90	4.00	4.10
D2	2.55	2.70	2.80
E	3.90	4.00	4.10
E2	2.55	2.70	2.80
e	0.45	0.50	0.55
L	0.25	0.35	0.45

Figure 13. QFN24L (4 x 4 mm) package dimensions

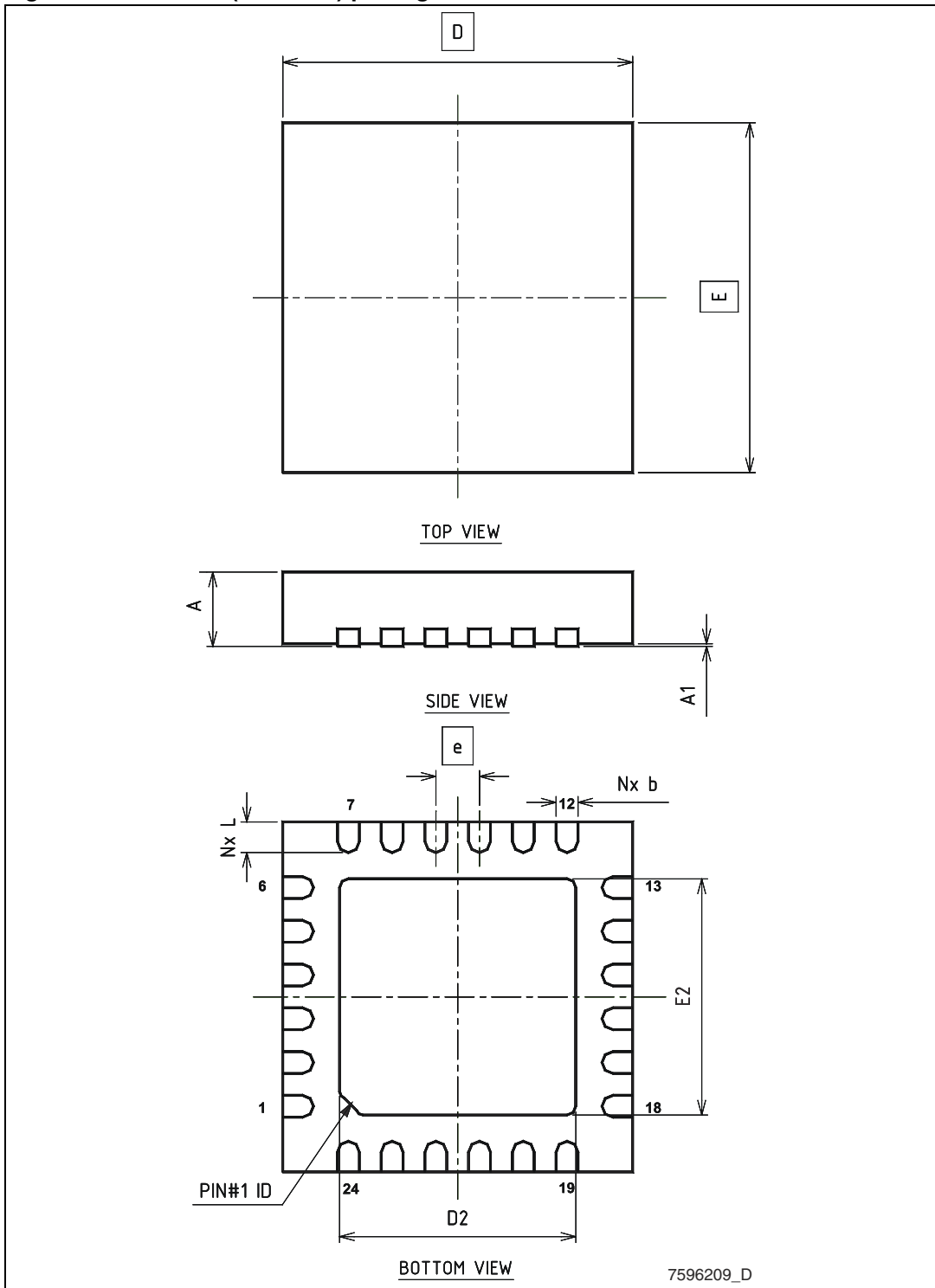

Tape & reel QFNxx/DFNxx (4x4) mechanical data

Dim.	mm.			inch.		
	Min.	Typ.	Max.	Min.	Typ.	Max.
A			330			12.992
C	12.8		13.2	0.504		0.519
D	20.2			0.795		
N	99		101	3.898		3.976
T			14.4			0.567
Ao		4.35			0.171	
Bo		4.35			0.171	
Ko		1.1			0.043	
Po		4			0.157	
P		8			0.315	

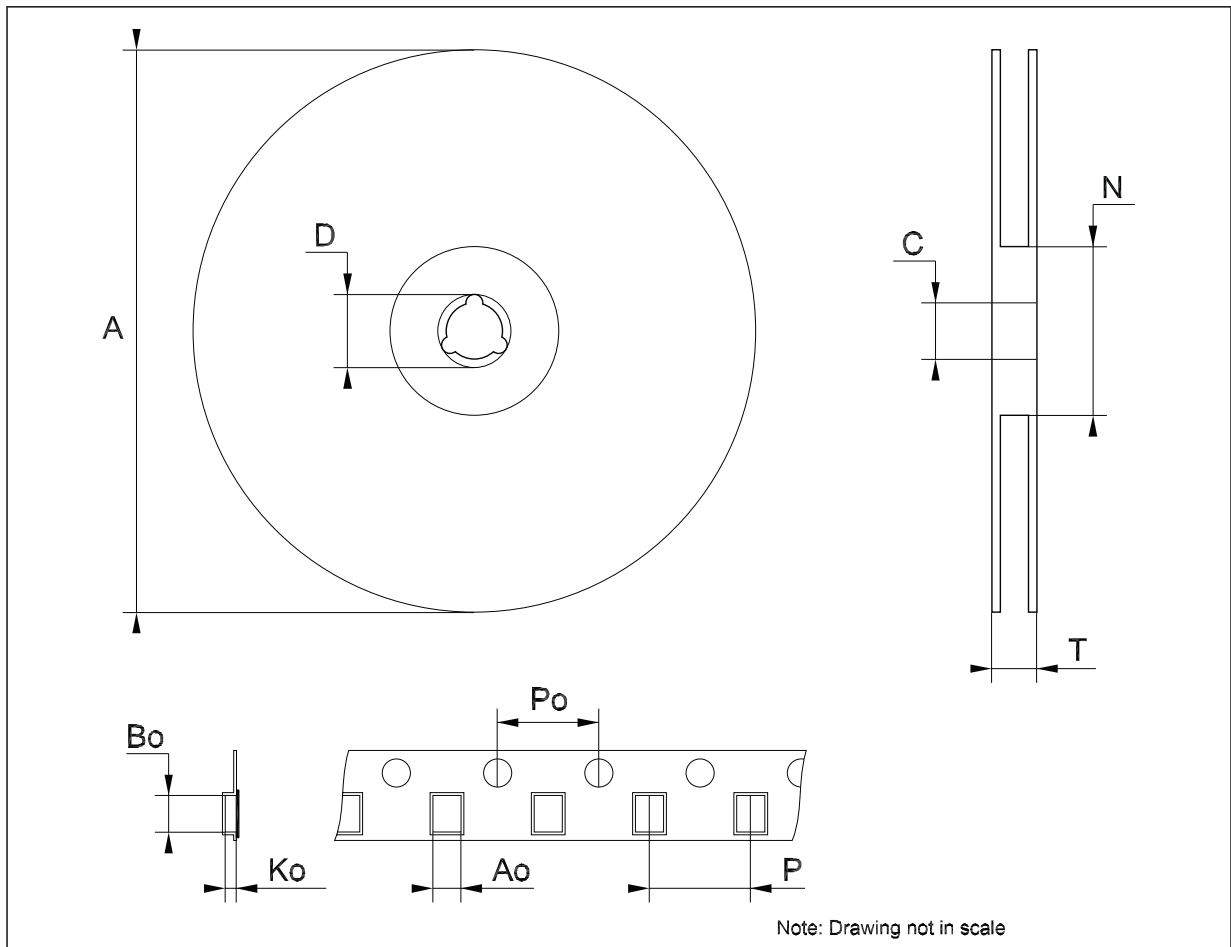
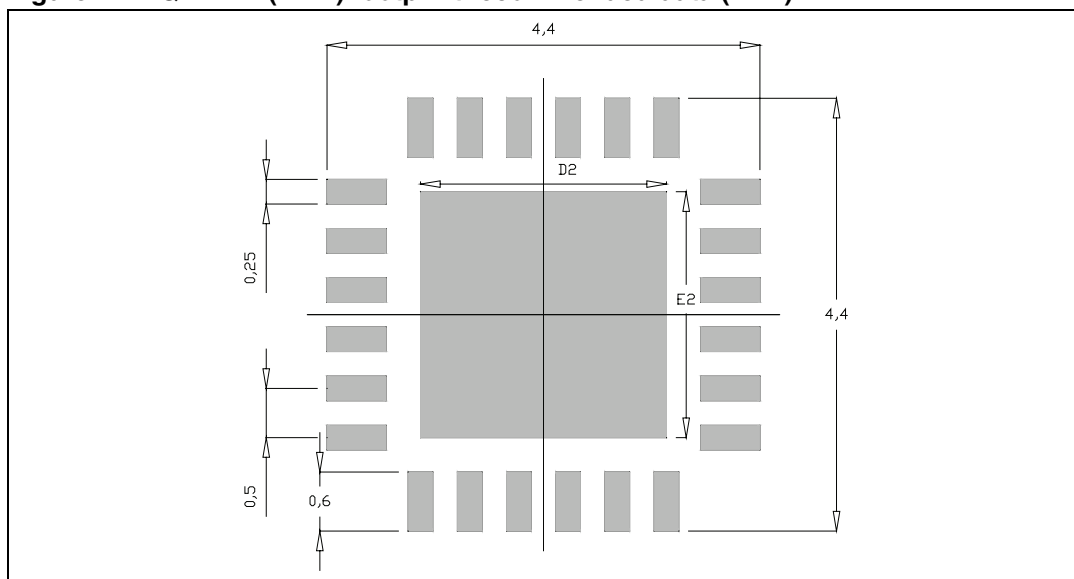

Figure 14. QFN24L (4 x 4) footprint recommended data (mm.)



10 Revision history

Table 21. Document revision history

Date	Revision	Changes
03-Feb-2012	1	Initial release.

Please Read Carefully:

Information in this document is provided solely in connection with ST products. STMicroelectronics NV and its subsidiaries ("ST") reserve the right to make changes, corrections, modifications or improvements, to this document, and the products and services described herein at any time, without notice.

All ST products are sold pursuant to ST's terms and conditions of sale.

Purchasers are solely responsible for the choice, selection and use of the ST products and services described herein, and ST assumes no liability whatsoever relating to the choice, selection or use of the ST products and services described herein.

No license, express or implied, by estoppel or otherwise, to any intellectual property rights is granted under this document. If any part of this document refers to any third party products or services it shall not be deemed a license grant by ST for the use of such third party products or services, or any intellectual property contained therein or considered as a warranty covering the use in any manner whatsoever of such third party products or services or any intellectual property contained therein.

UNLESS OTHERWISE SET FORTH IN ST'S TERMS AND CONDITIONS OF SALE ST DISCLAIMS ANY EXPRESS OR IMPLIED WARRANTY WITH RESPECT TO THE USE AND/OR SALE OF ST PRODUCTS INCLUDING WITHOUT LIMITATION IMPLIED WARRANTIES OF MERCHANTABILITY, FITNESS FOR A PARTICULAR PURPOSE (AND THEIR EQUIVALENTS UNDER THE LAWS OF ANY JURISDICTION), OR INFRINGEMENT OF ANY PATENT, COPYRIGHT OR OTHER INTELLECTUAL PROPERTY RIGHT.

UNLESS EXPRESSLY APPROVED IN WRITING BY TWO AUTHORIZED ST REPRESENTATIVES, ST PRODUCTS ARE NOT RECOMMENDED, AUTHORIZED OR WARRANTED FOR USE IN MILITARY, AIR CRAFT, SPACE, LIFE SAVING, OR LIFE SUSTAINING APPLICATIONS, NOR IN PRODUCTS OR SYSTEMS WHERE FAILURE OR MALFUNCTION MAY RESULT IN PERSONAL INJURY, DEATH, OR SEVERE PROPERTY OR ENVIRONMENTAL DAMAGE. ST PRODUCTS WHICH ARE NOT SPECIFIED AS "AUTOMOTIVE GRADE" MAY ONLY BE USED IN AUTOMOTIVE APPLICATIONS AT USER'S OWN RISK.

Resale of ST products with provisions different from the statements and/or technical features set forth in this document shall immediately void any warranty granted by ST for the ST product or service described herein and shall not create or extend in any manner whatsoever, any liability of ST.

ST and the ST logo are trademarks or registered trademarks of ST in various countries.

Information in this document supersedes and replaces all information previously supplied.

The ST logo is a registered trademark of STMicroelectronics. All other names are the property of their respective owners.

© 2012 STMicroelectronics - All rights reserved



STMicroelectronics group of companies

Australia - Belgium - Brazil - Canada - China - Czech Republic - Finland - France - Germany - Hong Kong - India - Israel - Italy - Japan - Malaysia - Malta - Morocco - Philippines - Singapore - Spain - Sweden - Switzerland - United Kingdom - United States of America





www.st.com

Looking for pricing, stock, or lifecycle information?

Click below to explore more details on WIN SOURCE:

-  [View LNBH26PQR](#) on WIN SOURCE
-  [STMicroelectronics](#) Information

Optimize Your Supply Chain with WIN SOURCE Solutions

-  Global Sourcing Solution
-  Obsolete Management
-  Cost Control Management
-  Shortage Management
-  Alternative Solution
-  Excess Inventory Management