



**THE DATASHEET OF
SN55113J**



SN55113, SN75113 DUAL DIFFERENTIAL LINE DRIVERS

SLLS070C – SEPTEMBER 1973 – REVISED MARCH 1997

- Choice of Open-Collector, Open-Emitter, or 3-State Outputs
- High-Impedance Output State for Party-Line Applications
- Single-Ended or Differential AND/NAND Outputs
- Single 5-V Supply
- Dual Channel Operation
- Compatible With TTL
- Short-Circuit Protection
- High-Current Outputs
- Common and Individual Output Controls
- Clamp Diodes at Inputs and Outputs
- Easily Adaptable to SN55114 and SN75114 Applications
- Designed for Use With SN55115 and SN75115

description

The SN55113 and SN75113 dual differential line drivers with 3-state outputs are designed to provide all the features of the SN55114 and SN75114 line drivers with the added feature of driver output controls. Individual controls are provided for each output pair, as well as a common control for both output pairs. If any output is low, the associated output is in a high-impedance state and the output can neither drive nor load the bus. This permits many devices to be connected together on the same transmission line for party-line applications.

The output stages are similar to TTL totem-pole outputs, but with the sink outputs, YS and ZS, and the corresponding active pullup terminals, YP and ZP, available on adjacent package pins.

The SN55113 is characterized for operation over the full military temperature range of -55°C to 125°C . The SN75113 is characterized for operation over the temperature range of 0°C to 70°C .

SN55113 . . . J OR W PACKAGE
SN75113 . . . N PACKAGE
(TOP VIEW)

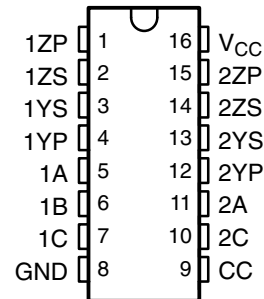

SN55113 . . . FK PACKAGE
(TOP VIEW)

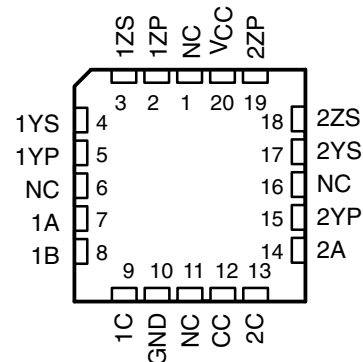

NC – No internal connection



Please be aware that an important notice concerning availability, standard warranty, and use in critical applications of Texas Instruments semiconductor products and disclaimers thereto appears at the end of this data sheet.

PRODUCTION DATA information is current as of publication date. Products conform to specifications per the terms of Texas Instruments standard warranty. Production processing does not necessarily include testing of all parameters.

 **TEXAS
INSTRUMENTS**

POST OFFICE BOX 655303 • DALLAS, TEXAS 75265

Copyright © 1997, Texas Instruments Incorporated

SN55113, SN75113 DUAL DIFFERENTIAL LINE DRIVERS

SLLS070C – SEPTEMBER 1973 – REVISED MARCH 1997

FUNCTION TABLE

INPUTS		OUTPUTS			
OUTPUT C	CONTROL CC	DATA		AND Y	NAND Z
		A	B†		
L	X	X	X	Z	Z
X	L	X	X	Z	Z
H	H	L	X	L	H
H	H	X	L	L	H
H	H	H	H	H	L

H = high level, L = low level, X = irrelevant,

Z = high impedance (off)

† B input and 4th line of function table are applicable only to driver number 1.

logic symbol‡

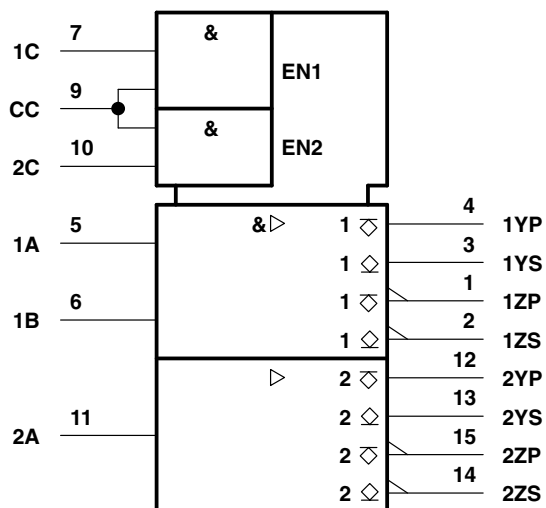

logic diagram (positive logic)

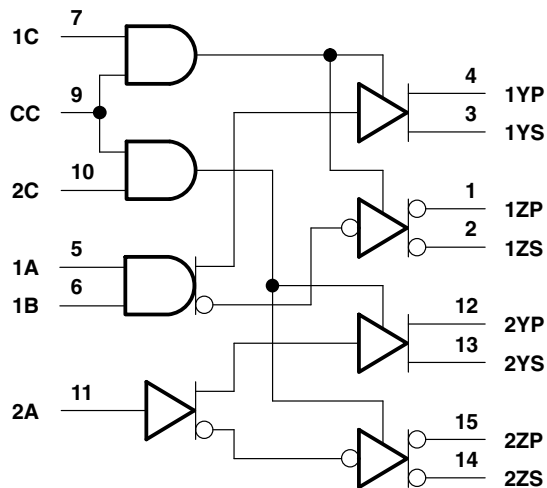

‡ This symbol is in accordance with ANSI/IEEE Std 91-1984 and IEC Publication 617-12.

Pin numbers shown are for the J, N, and W packages.

SN55113, SN75113 DUAL DIFFERENTIAL LINE DRIVERS

SLLS070C – SEPTEMBER 1973 – REVISED MARCH 1997

schematic

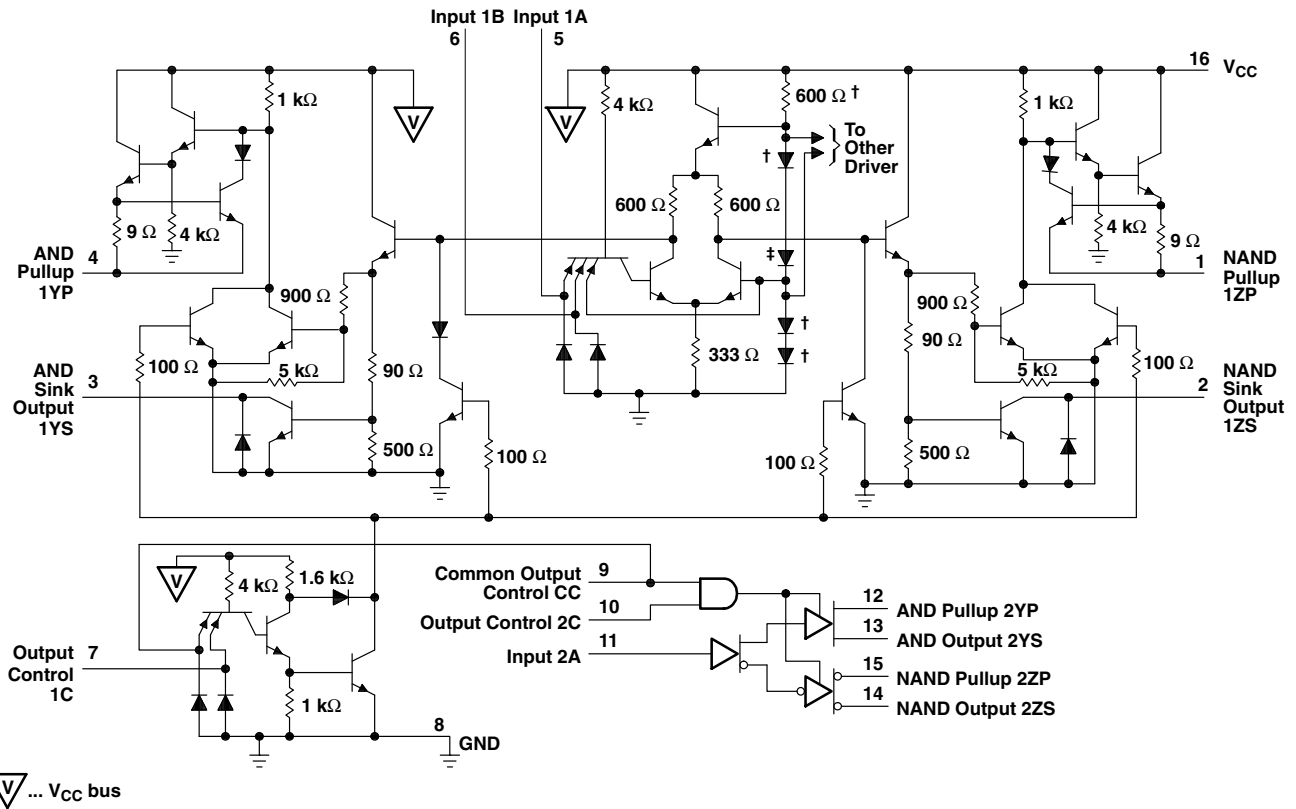

† These components are common to both drivers. Resistor values shown are nominal and in ohms.

absolute maximum ratings over operating free-air temperature range (unless otherwise noted)‡

Supply voltage, V_{CC} (see Note 1)	7 V
Input voltage, V_I	5.5 V
Off-state voltage applied to open-collector outputs	12 V
Continuous total power dissipation (see Note 2)	See Dissipation Rating Table
Operating free-air temperature range, T_A : SN55113	-55°C to 125°C
SN75113	0°C to 70°C
Storage temperature range, T_{stg}	-65°C to 150°C
Lead temperature 1,6 mm (1/16 inch) from case for 10 seconds: N package	260°C
Case temperature for 60 seconds: FK package	260°C
Lead temperature 1,6 mm (1/16 inch) from case for 60 seconds: J or W package	300°C

‡ Stresses beyond those listed under "absolute maximum ratings" may cause permanent damage to the device. These are stress ratings only, and functional operation of the device at these or any other conditions beyond those indicated under "recommended operating conditions" is not implied. Exposure to absolute-maximum-rated conditions for extended periods may affect device reliability.

DISSIPATION RATING TABLE

PACKAGE	$T_A \leq 25^\circ\text{C}$ POWER RATING	DERATING FACTOR ABOVE $T_A = 25^\circ\text{C}$	$T_A = 70^\circ\text{C}$ POWER RATING	$T_A = 125^\circ\text{C}$ POWER RATING
FK	1375 mW	11.0 mW/°C	880 mW	275 mW
J	1375 mW	11.0 mW/°C	880 mW	275 mW
N	1150 mW	9.2 mW/°C	736 mW	N/A
W	1000 mW	8.0 mW/°C	640 mW	200 mW



SN55113, SN75113 DUAL DIFFERENTIAL LINE DRIVERS

SLLS070C – SEPTEMBER 1973 – REVISED MARCH 1997

recommended operating conditions

	SN55113			SN75113			UNIT
	MIN	NOM	MAX	MIN	NOM	MAX	
Supply voltage, V_{CC}	4.5	5	5.5	4.75	5	5.25	V
High-level input voltage, V_{IH}	2			2			V
Low-level input voltage, V_{IL}			0.8			0.8	V
High-level output current, I_{OH}			-40			-40	mA
Low-level output current, I_{OL}			40			40	mA
Operating free-air temperature, T_A	-55		125	0		70	°C

electrical characteristics over recommended operating free-air temperature range (unless otherwise noted)

PARAMETER		TEST CONDITIONS†		SN55113			SN75113			UNIT		
				MIN	TYP‡	MAX	MIN	TYP‡	MAX			
V_{IK}	Input clamp voltage	$V_{CC} = \text{MIN}$, $I_I = -12 \text{ mA}$		-0.9		-1.5	-0.9		-1.5	V		
V_{OH}	High-level output voltage	$V_{CC} = \text{MIN}$, $V_{IL} = 0.8 \text{ V}$	$V_{IH} = 2 \text{ V}$	$I_{OH} = -10 \text{ mA}$	2.4	3.4	2.4	3.4		V		
				$I_{OH} = -40 \text{ mA}$	2	3.0	2	3.0				
V_{OL}	Low-level output voltage	$V_{CC} = \text{MIN}$, $I_{OL} = 40 \text{ mA}$	$V_{IH} = 2 \text{ V}$	$V_{IL} = 0.8 \text{ V}$		0.23	0.4	0.23	0.4	V		
V_{OK}	Output clamp voltage	$V_{CC} = \text{MAX}$, $I_O = -40 \text{ mA}$		-1.1		-1.5	-1.1		-1.5	V		
$I_{O(\text{off})}$	Off-state open-collector output current	$V_{CC} = \text{MAX}$	$V_{OH} = 12 \text{ V}$	$T_A = 25^\circ\text{C}$	1	10				μA		
				$T_A = 125^\circ\text{C}$		200						
			$V_{OH} = 5.25 \text{ V}$	$T_A = 25^\circ\text{C}$			1	10				
				$T_A = 70^\circ\text{C}$				20				
I_{OZ}	Off-state (high-impedance-state) output current	$V_{CC} = \text{MAX}$, Output controls at 0.8 V	$T_A = \text{MAX}$	$T_A = 25^\circ\text{C}$, $V_O = 0 \text{ to } V_{CC}$	± 10		± 10		μA			
				$V_O = 0$	-150	-20						
				$V_O = 0.4 \text{ V}$	± 80	± 20						
				$V_O = 2.4 \text{ V}$	± 80	± 20						
				$V_O = V_{CC}$	80	20						
I_I	Input current at maximum input voltage	A, B, C	$V_{CC} = \text{MAX}$, $V_I = 5.5 \text{ V}$		1			1	mA			
		CC			2			2				
I_{IH}	High-level input current	A, B, C	$V_{CC} = \text{MAX}$, $V_I = 2.4 \text{ V}$		40			40	μA			
		CC			80			80				
I_{IL}	Low-level input current	A, B, C	$V_{CC} = \text{MAX}$, $V_I = 0.4 \text{ V}$		-1.6			-1.6	mA			
		CC			-3.2			-3.2				
I_{OS}	Short-circuit output current§	$V_{CC} = \text{MAX}$, $V_O = 0$		$T_A = 25^\circ\text{C}$		-40	-90	-120	-40	-90	-120	mA
I_{CC}	Supply current (both drivers)	All inputs at 0 V, No load, $T_A = 25^\circ\text{C}$		$V_{CC} = \text{MAX}$		47	65	47	65	mA		
				$V_{CC} = 7 \text{ V}$		65	85	65	85			

† All parameters with the exception of off-state open-collector output current are measured with the active pullup connected to the sink output. For conditions shown as MIN or MAX, use the appropriate value specified under recommended operating conditions.

‡ All typical values are at $T_A = 25^\circ\text{C}$ and $V_{CC} = 5 \text{ V}$, with the exception of V_{CC} at 7 V.

§ Only one output should be shorted at a time, and duration of the short-circuit should not exceed one second.



switching characteristics, $V_{CC} = 5\text{ V}$, $C_L = 30\text{ pF}$, $T_A = 25^\circ\text{C}$

PARAMETER	TEST CONDITIONS	SN55113			SN75113			UNIT
		MIN	TYP	MAX	MIN	TYP	MAX	
t_{PLH} Propagation delay time, low-to-high level output	See Figure 1		13	20		13	30	ns
t_{PHL} Propagation delay time, high-to-low-level output			12	20		12	30	ns
t_{PZH} Output enable time to high level	$R_L = 180\ \Omega$, See Figure 2		7	15		7	20	ns
t_{PZL} Output enable time to low level	$R_L = 250\ \Omega$, See Figure 3		14	30		14	40	ns
t_{PHZ} Output disable time from high level	$R_L = 180\ \Omega$, See Figure 2		10	20		10	30	ns
t_{PLZ} Output disable time from low level	$R_L = 250\ \Omega$, See Figure 3		17	35		17	35	ns

PARAMETER MEASUREMENT INFORMATION

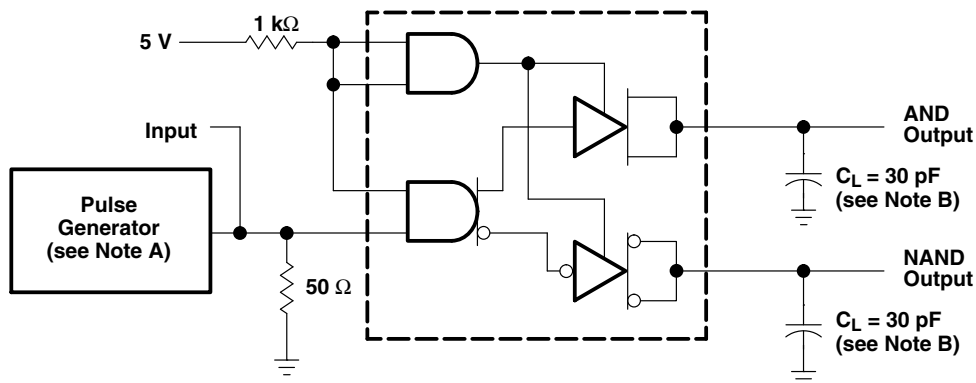

TEST CIRCUIT

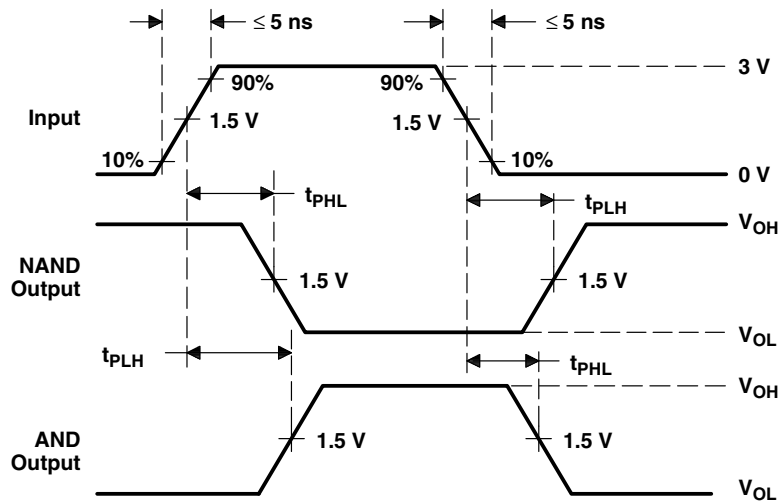

VOLTAGE WAVEFORMS

- NOTES: A. The pulse generator has the following characteristics: $Z_O = 50\ \Omega$, $PRR \leq 500\text{ kHz}$, $t_w = 100\text{ ns}$.
 B. C_L includes probe and jig capacitance.

Figure 1. Test Circuit and Voltage Waveforms t_{PLH} and t_{PHL}

SN55113, SN75113 DUAL DIFFERENTIAL LINE DRIVERS

SLLS070C – SEPTEMBER 1973 – REVISED MARCH 1997

PARAMETER MEASUREMENT INFORMATION

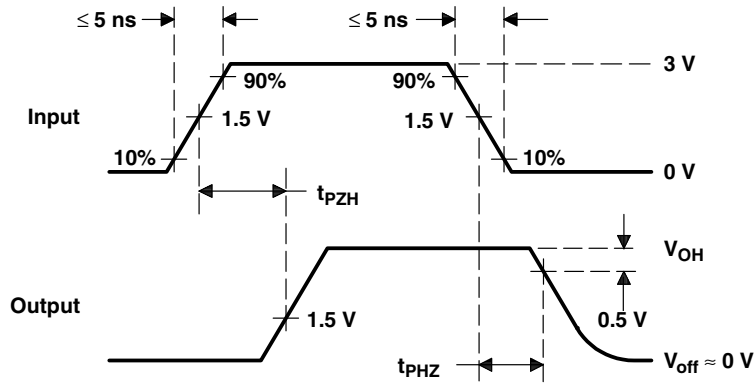
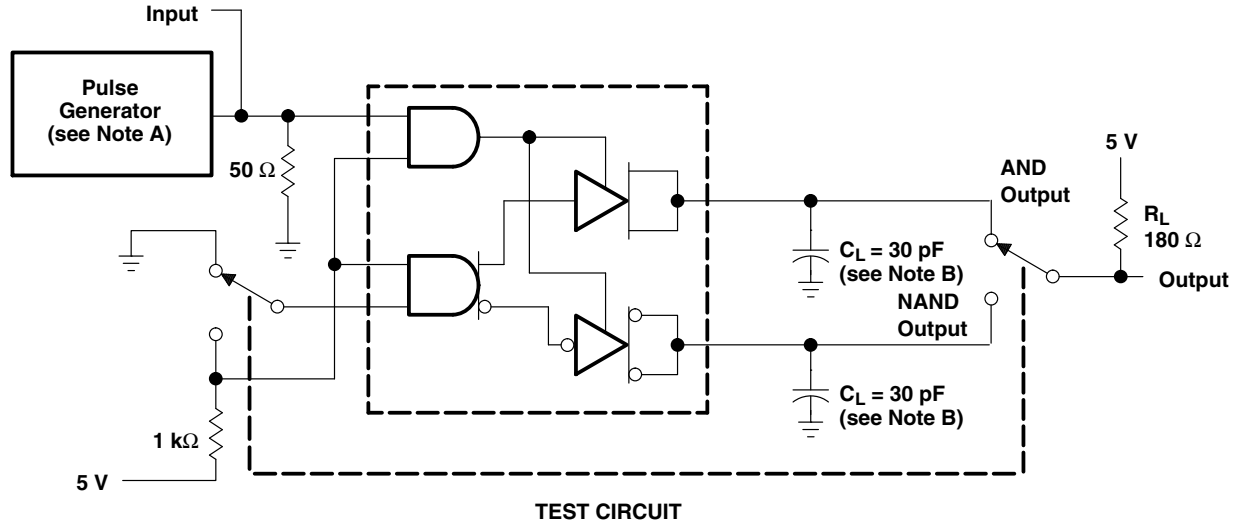

VOLTAGE WAVEFORMS

- NOTES: A. The pulse generator has the following characteristics: $Z_O = 50 \Omega$, $PRR \leq 500 \text{ kHz}$, $t_w = 100 \text{ ns}$.
B. C_L includes probe and jig capacitance.

Figure 2. Test Circuit and Voltage Waveforms t_{pZH} and t_{pHZ}

PARAMETER MEASUREMENT INFORMATION

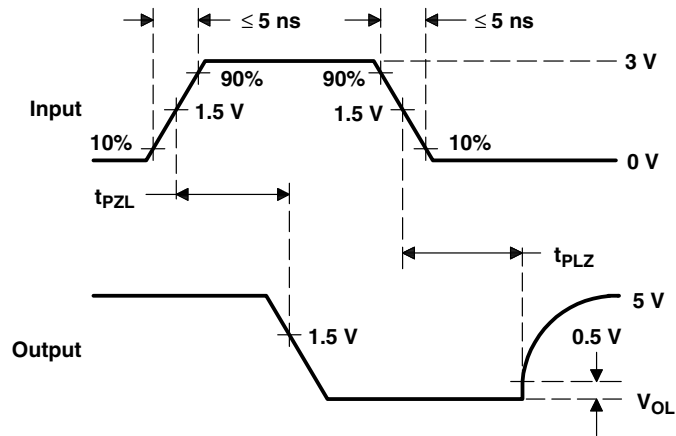
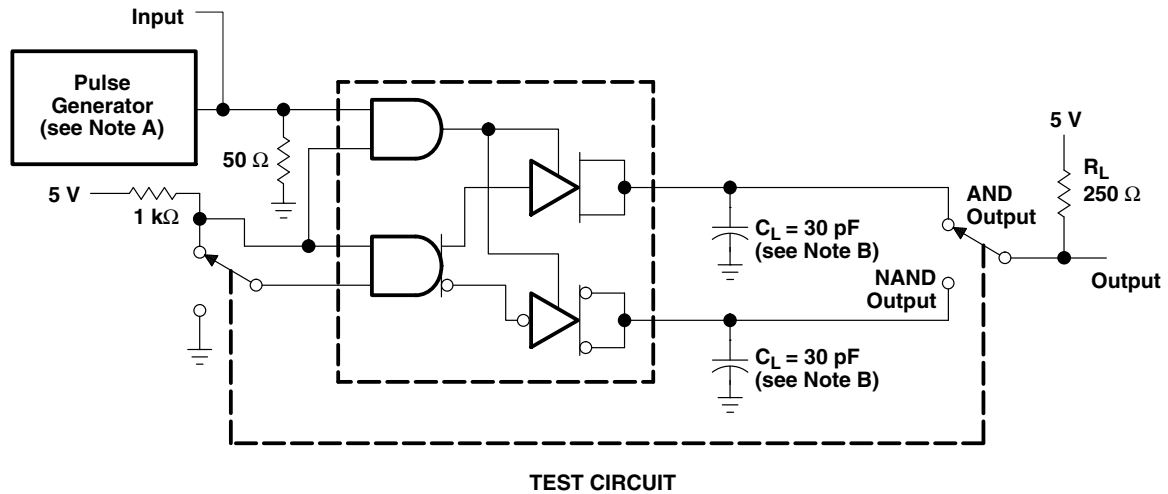

VOLTAGE WAVEFORMS

- NOTES: A. The pulse generator has the following characteristics: $Z_O = 50 \Omega$, $PRR \leq 500 \text{ kHz}$, $t_w = 100 \text{ ns}$.
 B. C_L includes probe and jig capacitance.

Figure 3. Test Circuit and Voltage Waveforms, t_{pZL} and t_{pLZ}

SN55113, SN75113 DUAL DIFFERENTIAL LINE DRIVERS

SLLS070C – SEPTEMBER 1973 – REVISED MARCH 1997

TYPICAL CHARACTERISTICS†

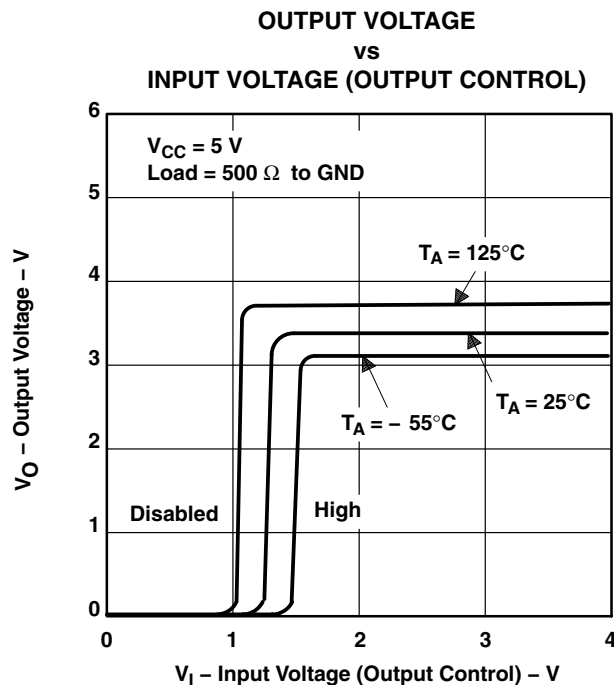
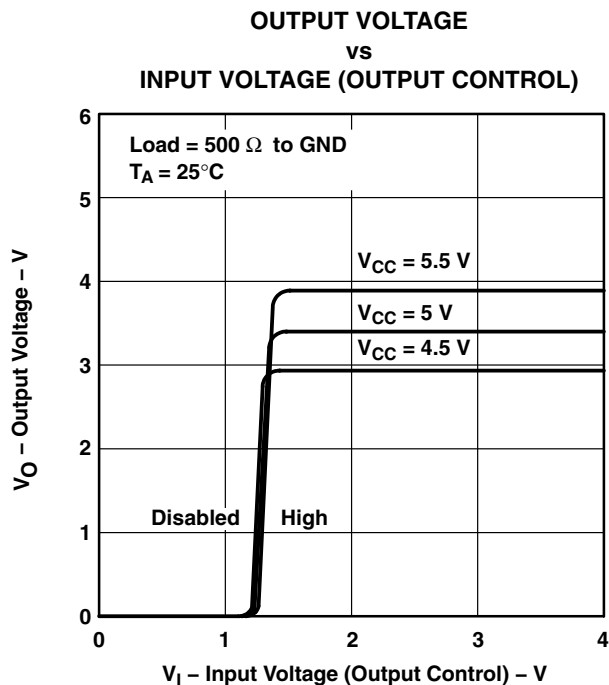
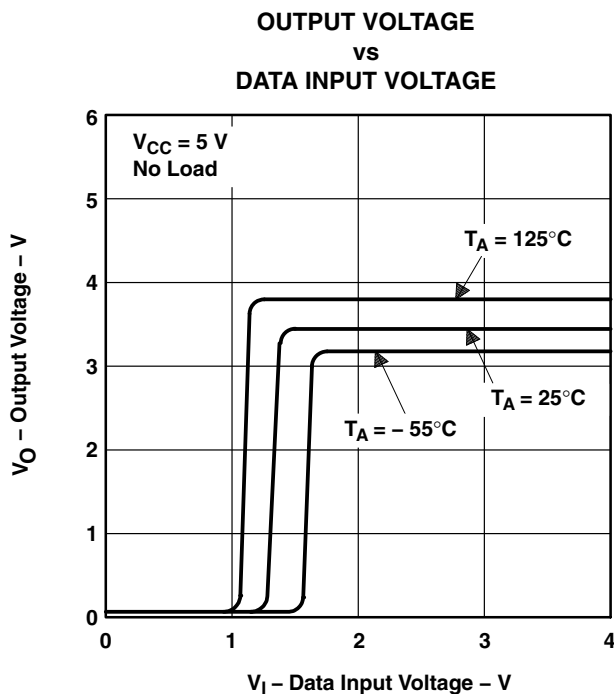
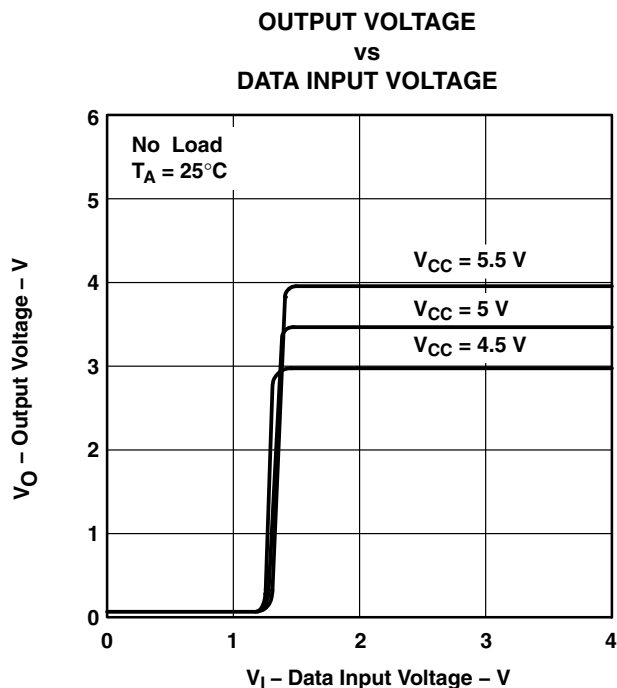

† Data for temperatures below 0°C and above 70°C and for supply voltages below 4.75 V and above 5.25 V are applicable to SN55113 circuits only. These parameters were measured with the active pullup connected to the sink output.

TYPICAL CHARACTERISTICS†

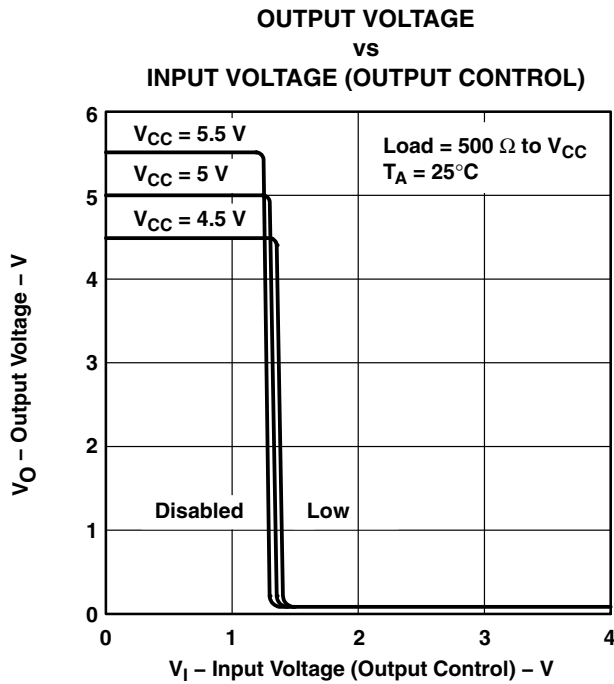

Figure 8

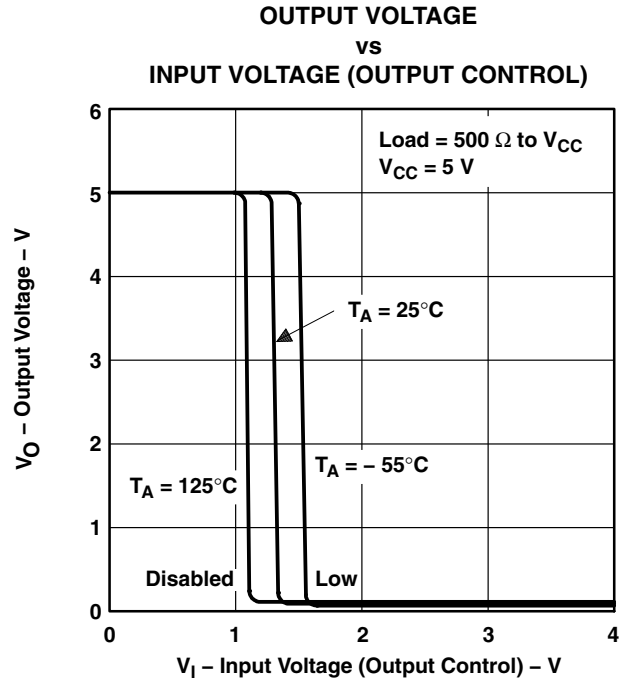

Figure 9

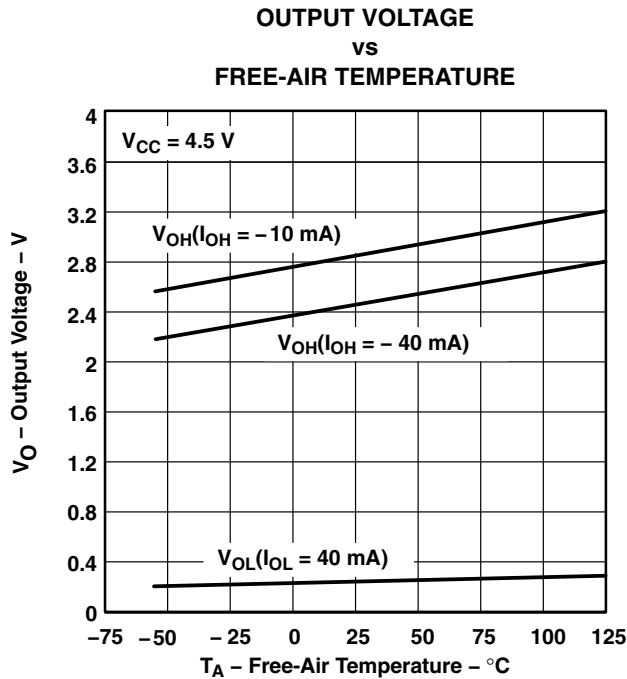

Figure 10

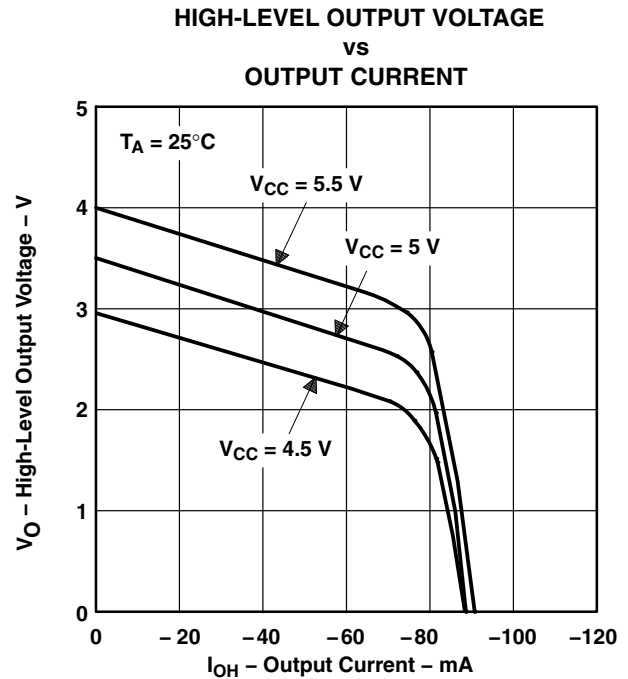

Figure 11

† Data for temperatures below 0°C and above 70°C and for supply voltages below 4.75 V and above 5.25 V are applicable to SN55113 circuits only. These parameters were measured with the active pullup connected to the sink output.

SN55113, SN75113 DUAL DIFFERENTIAL LINE DRIVERS

SLLS070C – SEPTEMBER 1973 – REVISED MARCH 1997

TYPICAL CHARACTERISTICS†

LOW-LEVEL OUTPUT VOLTAGE
vs
OUTPUT CURRENT

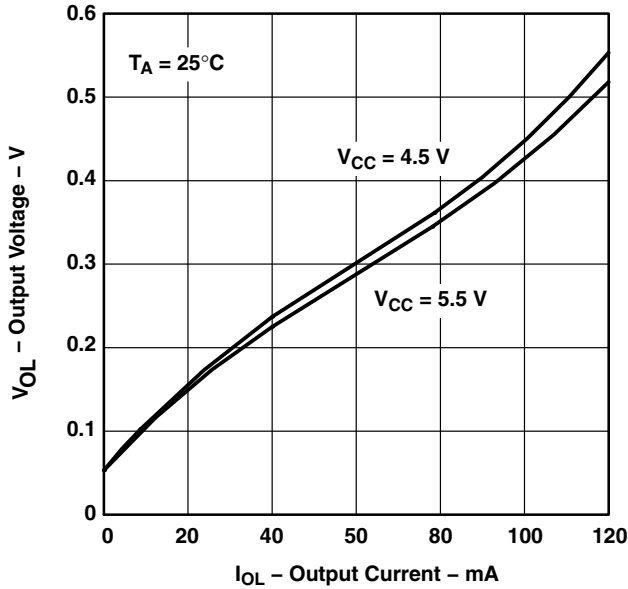

Figure 12

SUPPLY CURRENT
(BOTH DRIVERS)
vs
SUPPLY VOLTAGE

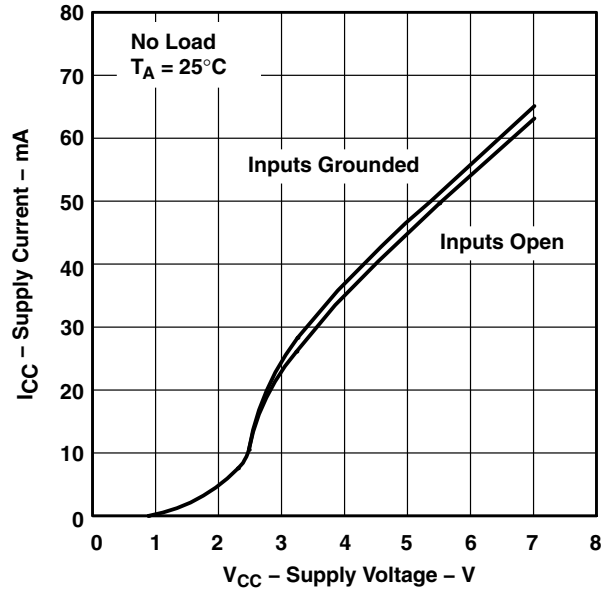

Figure 13

SUPPLY CURRENT
(BOTH DRIVERS)
vs
OUTPUT CURRENT

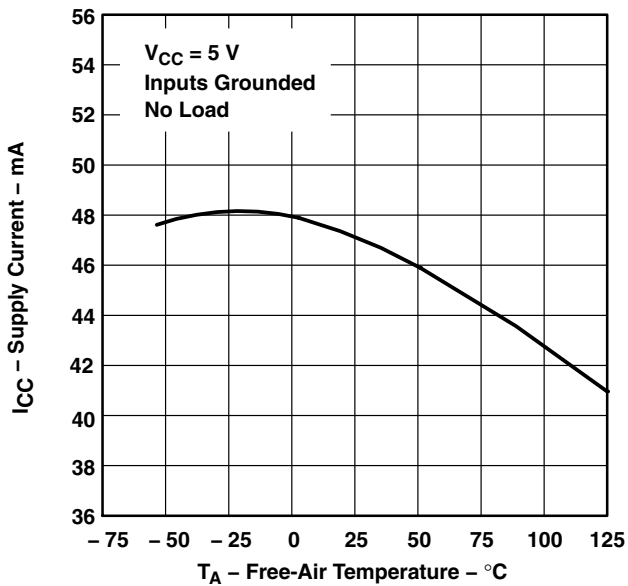

Figure 14

SUPPLY CURRENT
(BOTH DRIVERS)
vs
SUPPLY VOLTAGE

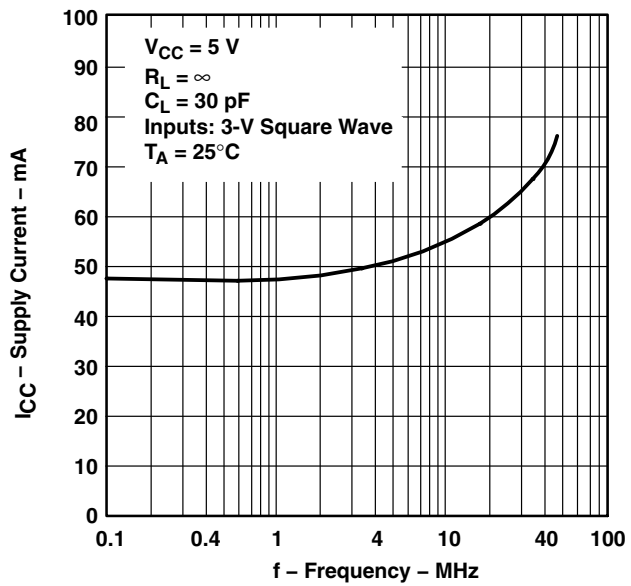
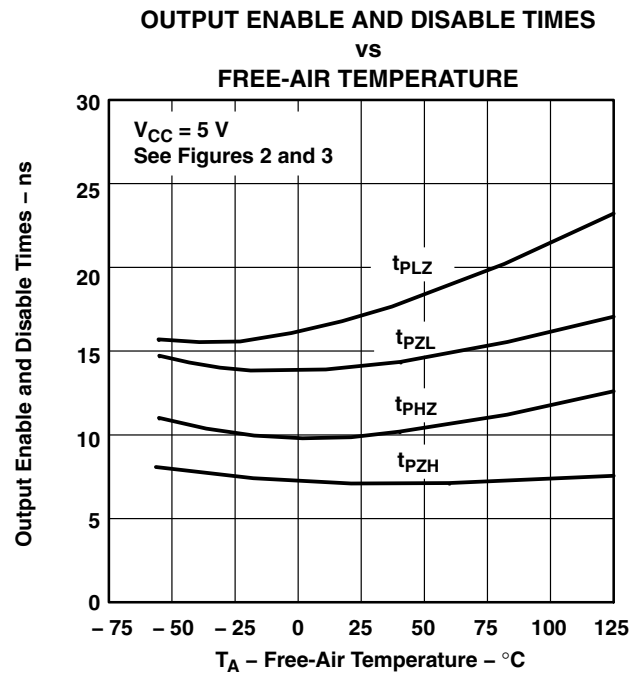
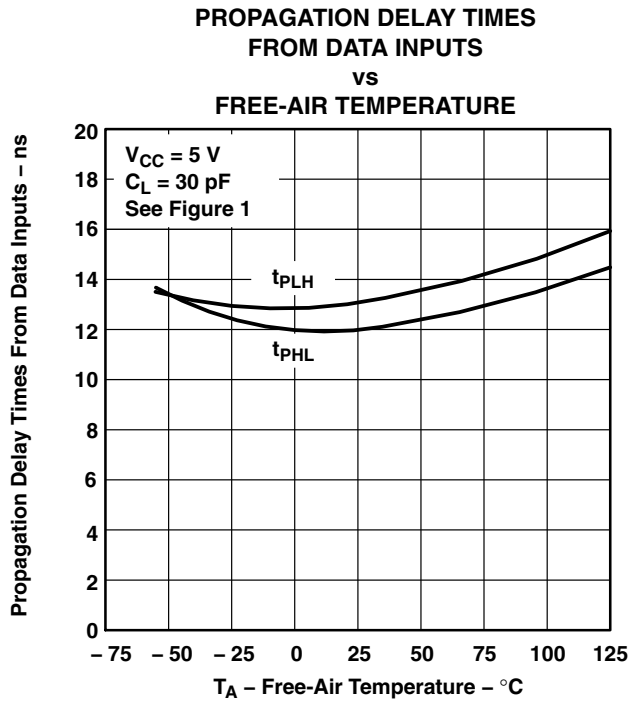

Figure 15

† Data for temperatures below 0°C and above 70°C and for supply voltages below 4.75 V and above 5.25 V are applicable to SN55113 circuits only. These parameters were measured with the active pullup connected to the sink output.



TYPICAL CHARACTERISTICS†



† Data for temperatures below 0°C and above 70°C and for supply voltages below 4.75 V and above 5.25 V are applicable to SN55113 circuits only. These parameters were measured with the active pullup connected to the sink output.

APPLICATION INFORMATION

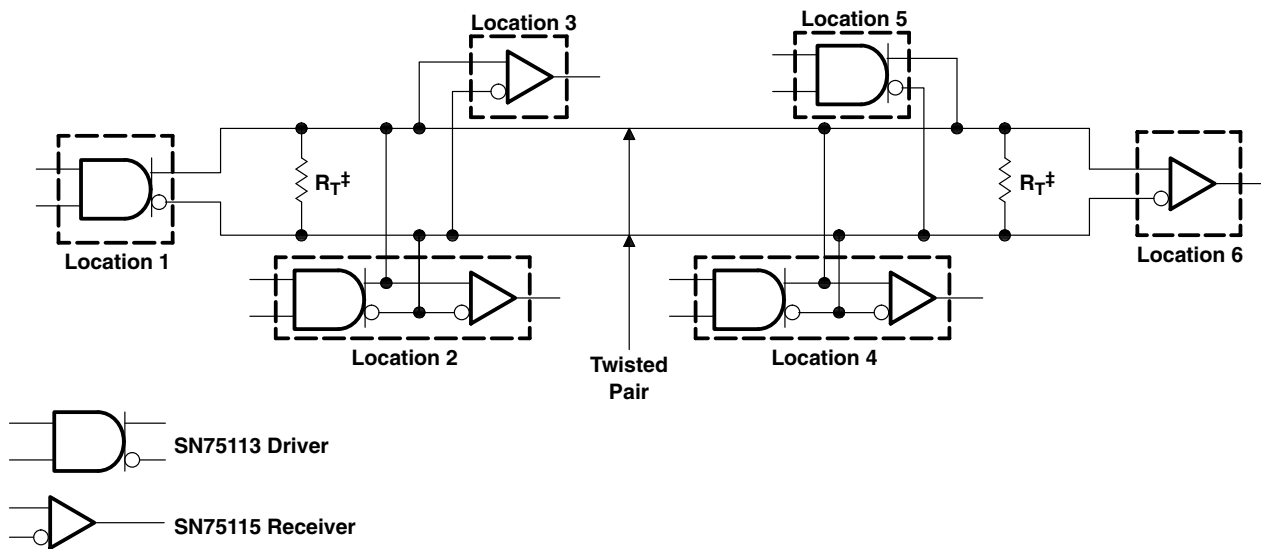

‡ $R_T = Z_0$. A capacitor may be connected in series with R_T to reduce power dissipation.

Figure 18. Basic Party-Line or Data-Bus Differential Data Transmission

PACKAGING INFORMATION

Orderable Device	Status (1)	Package Type	Package Drawing	Pins	Package Qty	Eco Plan (2)	Lead finish/ Ball material (6)	MSL Peak Temp (3)	Op Temp (°C)	Device Marking (4/5)	Samples
5962-88744012A	ACTIVE	LCCC	FK	20	55	Non-RoHS & Green	SNPB	N / A for Pkg Type	-55 to 125	5962- 88744012A SNJ55 113FK	Samples
5962-8874401EA	ACTIVE	CDIP	J	16	25	Non-RoHS & Green	SNPB	N / A for Pkg Type	-55 to 125	5962-8874401EA SNJ55113J	Samples
5962-8874401FA	ACTIVE	CFP	W	16	25	Non-RoHS & Green	SNPB	N / A for Pkg Type	-55 to 125	5962-8874401FA SNJ55113W	Samples
JM38510/10405BEA	ACTIVE	CDIP	J	16	25	Non-RoHS & Green	SNPB	N / A for Pkg Type	-55 to 125	JM38510 /10405BEA	Samples
M38510/10405BEA	ACTIVE	CDIP	J	16	25	Non-RoHS & Green	SNPB	N / A for Pkg Type	-55 to 125	JM38510 /10405BEA	Samples
SN55113J	ACTIVE	CDIP	J	16	25	Non-RoHS & Green	SNPB	N / A for Pkg Type	-55 to 125	SN55113J	Samples
SN75113N	ACTIVE	PDIP	N	16	25	RoHS & Green	NIPDAU	N / A for Pkg Type	0 to 70	SN75113N	Samples
SN75113NE4	ACTIVE	PDIP	N	16	25	RoHS & Green	NIPDAU	N / A for Pkg Type	0 to 70	SN75113N	Samples
SN75113NSR	ACTIVE	SO	NS	16	2000	RoHS & Green	NIPDAU	Level-1-260C-UNLIM	0 to 70	SN75113	Samples
SNJ55113FK	ACTIVE	LCCC	FK	20	55	Non-RoHS & Green	SNPB	N / A for Pkg Type	-55 to 125	5962- 88744012A SNJ55 113FK	Samples
SNJ55113J	ACTIVE	CDIP	J	16	25	Non-RoHS & Green	SNPB	N / A for Pkg Type	-55 to 125	5962-8874401EA SNJ55113J	Samples
SNJ55113W	ACTIVE	CFP	W	16	25	Non-RoHS & Green	SNPB	N / A for Pkg Type	-55 to 125	5962-8874401FA SNJ55113W	Samples

(1) The marketing status values are defined as follows:

ACTIVE: Product device recommended for new designs.

LIFEBUY: TI has announced that the device will be discontinued, and a lifetime-buy period is in effect.

NRND: Not recommended for new designs. Device is in production to support existing customers, but TI does not recommend using this part in a new design.

PREVIEW: Device has been announced but is not in production. Samples may or may not be available.

OBSOLETE: TI has discontinued the production of the device.

(2) **RoHS:** TI defines "RoHS" to mean semiconductor products that are compliant with the current EU RoHS requirements for all 10 RoHS substances, including the requirement that RoHS substance do not exceed 0.1% by weight in homogeneous materials. Where designed to be soldered at high temperatures, "RoHS" products are suitable for use in specified lead-free processes. TI may reference these types of products as "Pb-Free".

RoHS Exempt: TI defines "RoHS Exempt" to mean products that contain lead but are compliant with EU RoHS pursuant to a specific EU RoHS exemption.

Green: TI defines "Green" to mean the content of Chlorine (Cl) and Bromine (Br) based flame retardants meet JS709B low halogen requirements of ≤ 1000 ppm threshold. Antimony trioxide based flame retardants must also meet the ≤ 1000 ppm threshold requirement.

(3) MSL, Peak Temp. - The Moisture Sensitivity Level rating according to the JEDEC industry standard classifications, and peak solder temperature.

(4) There may be additional marking, which relates to the logo, the lot trace code information, or the environmental category on the device.

(5) Multiple Device Markings will be inside parentheses. Only one Device Marking contained in parentheses and separated by a "~" will appear on a device. If a line is indented then it is a continuation of the previous line and the two combined represent the entire Device Marking for that device.

(6) Lead finish/Ball material - Orderable Devices may have multiple material finish options. Finish options are separated by a vertical ruled line. Lead finish/Ball material values may wrap to two lines if the finish value exceeds the maximum column width.

Important Information and Disclaimer:The information provided on this page represents TI's knowledge and belief as of the date that it is provided. TI bases its knowledge and belief on information provided by third parties, and makes no representation or warranty as to the accuracy of such information. Efforts are underway to better integrate information from third parties. TI has taken and continues to take reasonable steps to provide representative and accurate information but may not have conducted destructive testing or chemical analysis on incoming materials and chemicals. TI and TI suppliers consider certain information to be proprietary, and thus CAS numbers and other limited information may not be available for release.

In no event shall TI's liability arising out of such information exceed the total purchase price of the TI part(s) at issue in this document sold by TI to Customer on an annual basis.

OTHER QUALIFIED VERSIONS OF SN55113, SN75113 :

● Catalog : [SN75113](#)

● Military : [SN55113](#)

NOTE: Qualified Version Definitions:

● Catalog - TI's standard catalog product

● Military - QML certified for Military and Defense Applications

TAPE AND REEL INFORMATION

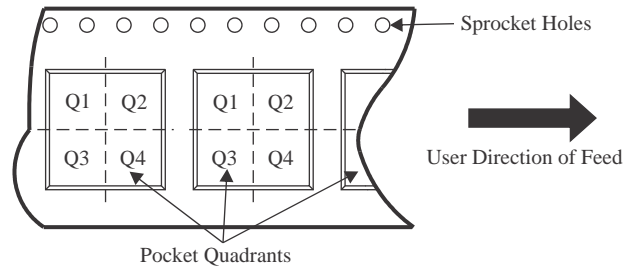
QUADRANT ASSIGNMENTS FOR PIN 1 ORIENTATION IN TAPE

*All dimensions are nominal

Device	Package Type	Package Drawing	Pins	SPQ	Reel Diameter (mm)	Reel Width W1 (mm)	A0 (mm)	B0 (mm)	K0 (mm)	P1 (mm)	W (mm)	Pin1 Quadrant
SN75113NSR	SO	NS	16	2000	330.0	16.4	8.2	10.5	2.5	12.0	16.0	Q1

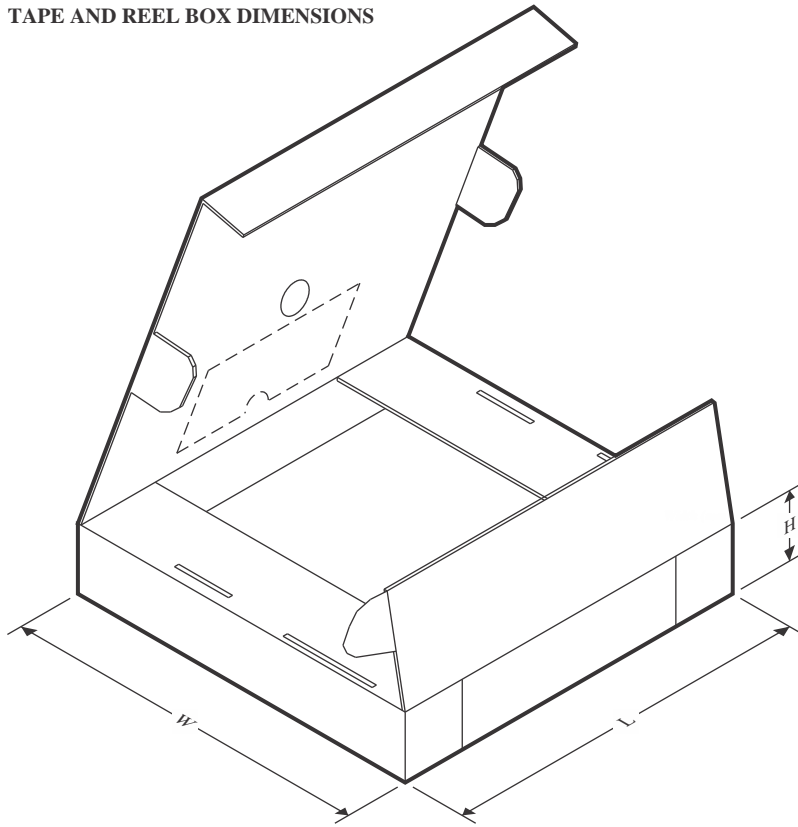
TAPE AND REEL BOX DIMENSIONS

*All dimensions are nominal

Device	Package Type	Package Drawing	Pins	SPQ	Length (mm)	Width (mm)	Height (mm)
SN75113NSR	SO	NS	16	2000	356.0	356.0	35.0

TUBE

*All dimensions are nominal

Device	Package Name	Package Type	Pins	SPQ	L (mm)	W (mm)	T (μm)	B (mm)
5962-88744012A	FK	LCCC	20	55	506.98	12.06	2030	NA
5962-8874401FA	W	CFP	16	25	506.98	26.16	6220	NA
SN75113N	N	PDIP	16	25	506	13.97	11230	4.32
SN75113NE4	N	PDIP	16	25	506	13.97	11230	4.32
SNJ55113FK	FK	LCCC	20	55	506.98	12.06	2030	NA
SNJ55113W	W	CFP	16	25	506.98	26.16	6220	NA



PACKAGE OUTLINE

NS0016A

SOP - 2.00 mm max height

SOP



4220735/A 12/2021

NOTES:

- All linear dimensions are in millimeters. Dimensions in parenthesis are for reference only. Dimensioning and tolerancing per ASME Y14.5M.
- This drawing is subject to change without notice.
- This dimension does not include mold flash, protrusions, or gate burrs. Mold flash, protrusions, or gate burrs shall not exceed 0.15 mm, per side.
- This dimension does not include interlead flash. Interlead flash shall not exceed 0.25 mm, per side.

EXAMPLE BOARD LAYOUT

NS0016A

SOP - 2.00 mm max height

SOP



4220735/A 12/2021

NOTES: (continued)

5. Publication IPC-7351 may have alternate designs.

6. Solder mask tolerances between and around signal pads can vary based on board fabrication site.

EXAMPLE STENCIL DESIGN

NS0016A

SOP - 2.00 mm max height

SOP



SOLDER PASTE EXAMPLE
BASED ON 0.125 mm THICK STENCIL
SCALE:7X

4220735/A 12/2021

NOTES: (continued)

7. Laser cutting apertures with trapezoidal walls and rounded corners may offer better paste release. IPC-7525 may have alternate design recommendations.
8. Board assembly site may have different recommendations for stencil design.

MECHANICAL DATA

NS (R-PDSO-G**)

PLASTIC SMALL-OUTLINE PACKAGE

14-PINS SHOWN



- NOTES:
- A. All linear dimensions are in millimeters.
 - B. This drawing is subject to change without notice.
 - C. Body dimensions do not include mold flash or protrusion, not to exceed 0,15.

W (R-GDFP-F16)

CERAMIC DUAL FLATPACK



- NOTES:
- A. All linear dimensions are in inches (millimeters).
 - B. This drawing is subject to change without notice.
 - C. This package can be hermetically sealed with a ceramic lid using glass frit.
 - D. Index point is provided on cap for terminal identification only.
 - E. Falls within MIL STD 1835 GDFP2-F16

GENERIC PACKAGE VIEW

FK 20

LCCC - 2.03 mm max height

8.89 x 8.89, 1.27 mm pitch

LEADLESS CERAMIC CHIP CARRIER

This image is a representation of the package family, actual package may vary.
Refer to the product data sheet for package details.



4229370VA\

J (R-GDIP-T**)

14 LEADS SHOWN

CERAMIC DUAL IN-LINE PACKAGE



DIM \ PINS **	14	16	18	20
A	0.300 (7,62) BSC	0.300 (7,62) BSC	0.300 (7,62) BSC	0.300 (7,62) BSC
B MAX	0.785 (19,94)	.840 (21,34)	0.960 (24,38)	1.060 (26,92)
B MIN	—	—	—	—
C MAX	0.300 (7,62)	0.300 (7,62)	0.310 (7,87)	0.300 (7,62)
C MIN	0.245 (6,22)	0.245 (6,22)	0.220 (5,59)	0.245 (6,22)



4040083/F 03/03

- NOTES:
- All linear dimensions are in inches (millimeters).
 - This drawing is subject to change without notice.
 - This package is hermetically sealed with a ceramic lid using glass frit.
 - Index point is provided on cap for terminal identification only on press ceramic glass frit seal only.
 - Falls within MIL STD 1835 GDIP1-T14, GDIP1-T16, GDIP1-T18 and GDIP1-T20.

N (R-PDIP-T**)

PLASTIC DUAL-IN-LINE PACKAGE

16 PINS SHOWN

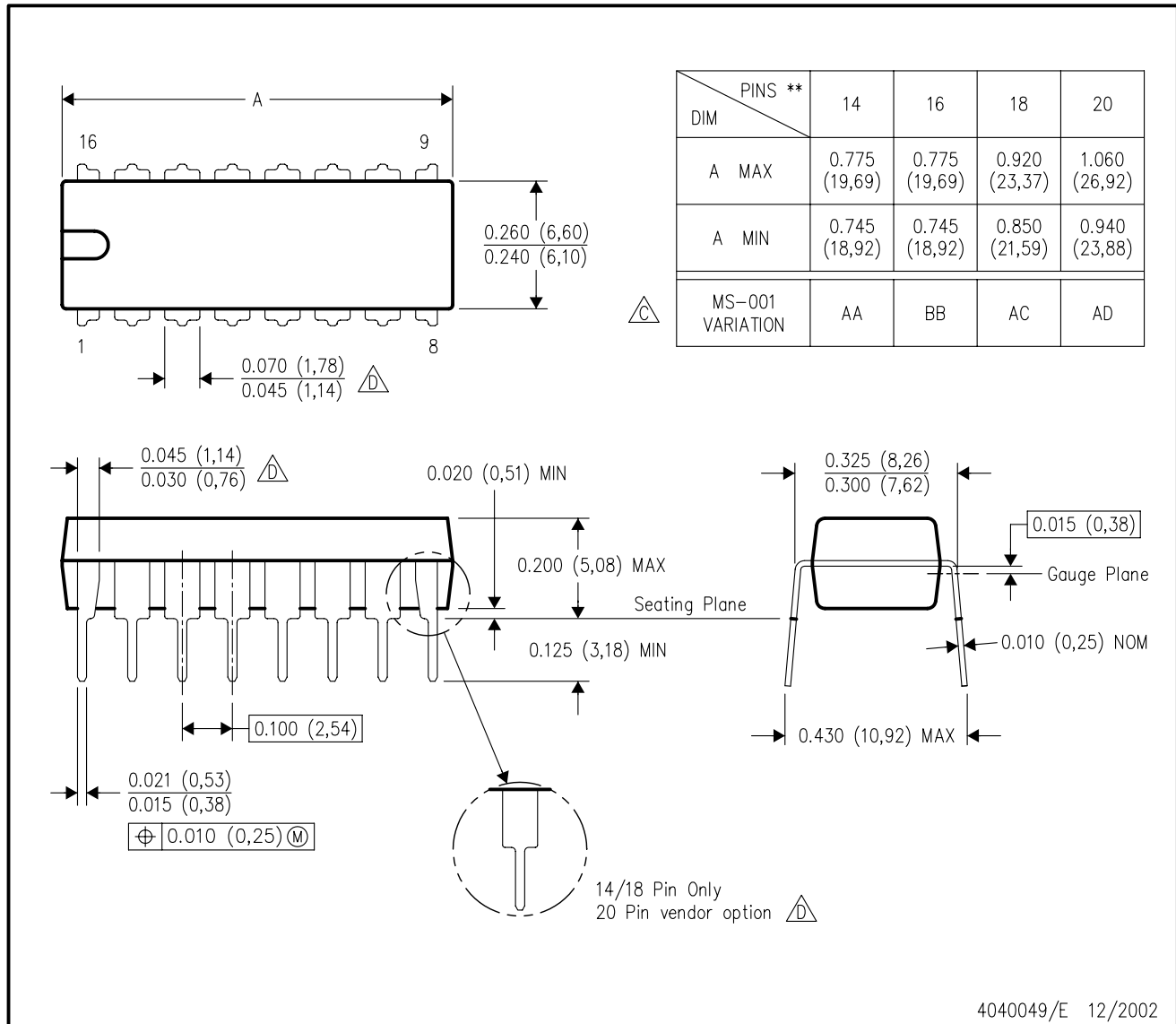

4040049/E 12/2002

- NOTES:
- A. All linear dimensions are in inches (millimeters).
 - B. This drawing is subject to change without notice.
 - (C) Falls within JEDEC MS-001, except 18 and 20 pin minimum body length (Dim A).
 - (D) The 20 pin end lead shoulder width is a vendor option, either half or full width.

IMPORTANT NOTICE AND DISCLAIMER

TI PROVIDES TECHNICAL AND RELIABILITY DATA (INCLUDING DATA SHEETS), DESIGN RESOURCES (INCLUDING REFERENCE DESIGNS), APPLICATION OR OTHER DESIGN ADVICE, WEB TOOLS, SAFETY INFORMATION, AND OTHER RESOURCES "AS IS" AND WITH ALL FAULTS, AND DISCLAIMS ALL WARRANTIES, EXPRESS AND IMPLIED, INCLUDING WITHOUT LIMITATION ANY IMPLIED WARRANTIES OF MERCHANTABILITY, FITNESS FOR A PARTICULAR PURPOSE OR NON-INFRINGEMENT OF THIRD PARTY INTELLECTUAL PROPERTY RIGHTS.

These resources are intended for skilled developers designing with TI products. You are solely responsible for (1) selecting the appropriate TI products for your application, (2) designing, validating and testing your application, and (3) ensuring your application meets applicable standards, and any other safety, security, regulatory or other requirements.

These resources are subject to change without notice. TI grants you permission to use these resources only for development of an application that uses the TI products described in the resource. Other reproduction and display of these resources is prohibited. No license is granted to any other TI intellectual property right or to any third party intellectual property right. TI disclaims responsibility for, and you will fully indemnify TI and its representatives against, any claims, damages, costs, losses, and liabilities arising out of your use of these resources.

TI's products are provided subject to [TI's Terms of Sale](#) or other applicable terms available either on [ti.com](https://www.ti.com) or provided in conjunction with such TI products. TI's provision of these resources does not expand or otherwise alter TI's applicable warranties or warranty disclaimers for TI products.

TI objects to and rejects any additional or different terms you may have proposed.

Mailing Address: Texas Instruments, Post Office Box 655303, Dallas, Texas 75265
Copyright © 2024, Texas Instruments Incorporated

Looking for pricing, stock, or lifecycle information?

Click below to explore more details on WIN SOURCE:

 [View SN55113J on WIN SOURCE](#)

 [Texas Instruments](#) Information

Optimize Your Supply Chain with WIN SOURCE Solutions

-  Global Sourcing Solution
-  Obsolete Management
-  Cost Control Management
-  Shortage Management
-  Alternative Solution
-  Excess Inventory Management