



THE DATASHEET OF AMC1100DUBR



AMC1100 Fully-Differential Isolation Amplifier

1 Features

- ± 250 -mV input voltage range optimized for shunt resistors
- Very low nonlinearity: 0.075% max at 5 V
- Low offset error: 1.5 mV max
- Low noise: 3.1 mV_{RMS} typ
- Low high-side supply current: 8 mA max at 5 V
- Input bandwidth: 60 kHz min
- Fixed gain: 8 (0.5% Accuracy)
- High common-mode rejection ratio: 108 dB
- Low-side operation: 3.3 V
- Safety-related certifications:
 - 4250-V_{PK} basic isolation per DIN VDE V 0884-11: 2017-01
 - 3005-V_{RMS} isolation for 1 minute per UL1577
 - CAN/CSA no. 5A-component acceptance service notice and DIN EN 61010-1 standard
 - Working voltage: 1200 V_{PEAK}
 - Transient immunity: 2.5 kV/ μ s min
- Fully specified over the extended industrial temperature range

2 Applications

Shunt resistor based current sensing in:

- [Electricity meters](#)
- [String inverters](#)
- Power measurement applications

3 Description

The AMC1100 is a precision isolation amplifier with an output separated from the input circuitry by a silicon dioxide (SiO₂) barrier that is highly resistant to magnetic interference. This barrier is certified to provide galvanic isolation of up to 4250 V_{PEAK}, according to DIN VDE V 0884-11: 2017-01 and UL1577. Used in conjunction with isolated power supplies, this device prevents noise currents on a high common-mode voltage line from entering the local ground and interfering with or damaging sensitive circuitry.

The AMC1100 input is optimized for direct connection to shunt resistors or other low voltage level signal sources. The excellent performance of the device enables accurate current and voltage measurement in energy-metering applications. The output signal common-mode voltage is automatically adjusted to either the 3-V or 5-V low-side supply.

The AMC1100 is fully specified over the extended industrial temperature range of -40°C to $+105^{\circ}\text{C}$ and is available in the SMD-type, wide-body SOIC-8 (DWV) and gullwing-8 (DUB) packages.

Device Information⁽¹⁾

PART NUMBER	PACKAGE	BODY SIZE (NOM)
AMC1100	SOP (8)	9.50 mm x 6.57 mm
	SOIC (8)	5.85 mm x 7.50 mm

(1) For all available packages, see the orderable addendum at the end of the datasheet.

Simplified Schematic

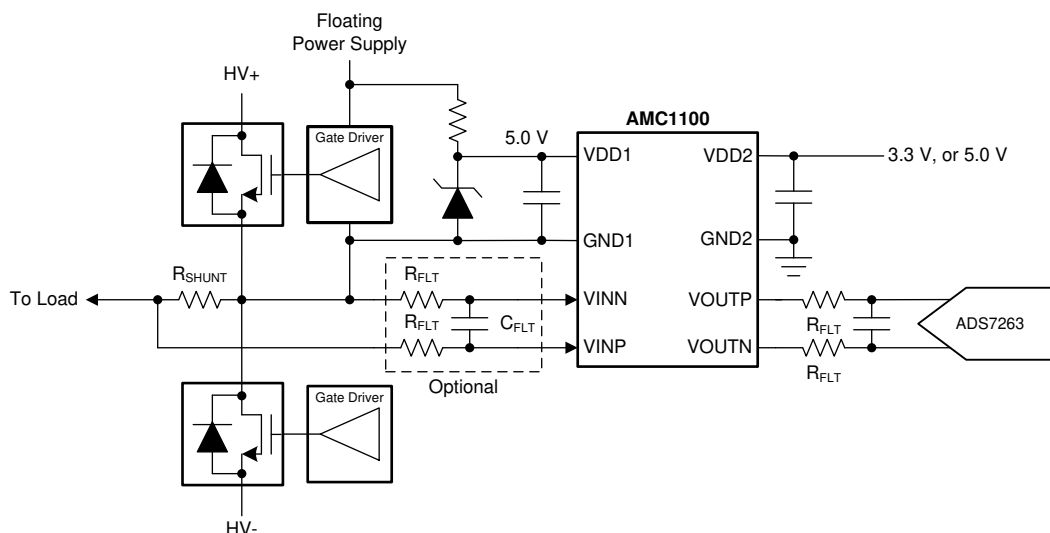

Table of Contents

1	Features	1	7.2	Functional Block Diagram	14
2	Applications	1	7.3	Feature Description	15
3	Description	1	7.4	Device Functional Modes	16
4	Revision History	2	8	Application and Implementation	17
5	Pin Configuration and Functions	3	8.1	Application Information	17
6	Specifications	3	8.2	Typical Applications	17
6.1	Absolute Maximum Ratings	3	9	Power Supply Recommendations	21
6.2	ESD Ratings	3	10	Layout	22
6.3	Recommended Operating Conditions	4	10.1	Layout Guidelines	22
6.4	Thermal Information	4	10.2	Layout Example	22
6.5	Power Ratings	4	11	Device and Documentation Support	23
6.6	Insulation Specifications	5	11.1	Device Support	23
6.7	Safety-Related Certifications	6	11.2	Documentation Support	25
6.8	Safety Limiting Values	6	11.3	Receiving Notification of Documentation Updates	25
6.9	Electrical Characteristics	7	11.4	Support Resources	25
6.10	Insulation Characteristics Curves	8	11.5	Trademarks	25
6.11	Typical Characteristics	9	11.6	Electrostatic Discharge Caution	25
7	Detailed Description	14	11.7	Glossary	25
7.1	Overview	14	12	Mechanical, Packaging, and Orderable Information	25

4 Revision History

Changes from Revision A (December 2014) to Revision B	Page
• Changed certification details as per ISO standard in <i>safety-related certifications</i> Features bullet	1
• Deleted typical life span Features bullet	1
• Changed <i>Applications</i> section to include end equipment links	1
• Changed <i>IEC60747-5-2 to DIN VDE V 0884-11: 2017-01</i> in <i>Description</i> section	1
• Changed page 1 figure and added title	1
• Added <i>Power Ratings</i> table	4
• Changed <i>Insulation Specifications</i> table per ISO standard	5
• Added DWV-package related details in <i>Insulation Specifications</i> table	5
• Changed <i>Safety-Related Certification</i> table per ISO standard	6
• Changed <i>Safety Limiting Values</i> table per ISO standard	6
• Deleted VDD1 and VDD2 from <i>Electrical Characteristics</i> table (repeated in <i>Recommended Operating Conditions</i> table)	7
• Added <i>Insulation Characteristics Curves</i> section	8
• Changed <i>Zener Diode Based High-Side Supply</i> figure	21

Changes from Original (April 2012) to Revision A	Page
• Changed format to meet latest data sheet standards	1
• Added <i>ESD Rating</i> table and <i>Feature Description</i> , <i>Device Functional Modes</i> , <i>Application and Implementation</i> , <i>Power Supply Recommendations</i> , <i>Layout</i> , <i>Device and Documentation Support</i> , and <i>Mechanical, Packaging, and Orderable Information</i> sections	1
• Added DWV package to document	1
• Deleted <i>Package and Ordering Information</i> section	3

5 Pin Configuration and Functions

**DUB and DWV Packages
SOP-8 and SOIC-8
(Top View)**

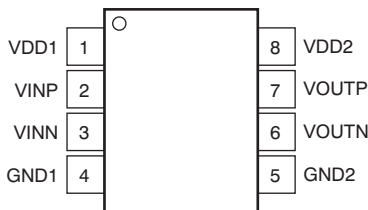

Pin Descriptions

PIN		FUNCTION	DESCRIPTION
NAME	NO.		
GND1	4	Power	High-side analog ground
GND2	5	Power	Low-side analog ground
VDD1	1	Power	High-side power supply
VDD2	8	Power	Low-side power supply
VINN	3	Analog input	Inverting analog input
VINP	2	Analog input	Noninverting analog input
VOUTN	6	Analog output	Inverting analog output
VOUTP	7	Analog output	Noninverting analog output

6 Specifications

6.1 Absolute Maximum Ratings

see⁽¹⁾

	MIN	MAX	UNIT
Supply voltage, VDD1 to GND1 or VDD2 to GND2	-0.5	6	V
Analog input voltage at VINP, VINN	GND1 - 0.5	VDD1 + 0.5	V
Input current to any pin except supply pins		±10	mA
Maximum junction temperature, T _J Max		150	°C
Storage temperature range, T _{stg}	-65	150	°C

- (1) Stresses beyond those listed under *Absolute Maximum Ratings* may cause permanent damage to the device. These are stress ratings only, which do not imply functional operation of the device at these or any other conditions beyond those indicated under *Recommended Operating Conditions*. Exposure to absolute-maximum-rated conditions for extended periods may affect device reliability.

6.2 ESD Ratings

			VALUE	UNIT
V _(ESD)	Electrostatic discharge	Human body model (HBM), per ANSI/ESDA/JEDEC JS-001 ⁽¹⁾	±2500	V
		Charged device model (CDM), per JEDEC specification JESD22-C101 ⁽²⁾	±1000	

- (1) JEDEC document JEP155 states that 500-V HBM allows safe manufacturing with a standard ESD control process.

- (2) JEDEC document JEP157 states that 250-V CDM allows safe manufacturing with a standard ESD control process.

6.3 Recommended Operating Conditions

over operating free-air temperature range (unless otherwise noted)

		MIN	NOM	MAX	UNIT
T_A	Operating ambient temperature range	–40		105	°C
VDD1	High-side power supply	4.5	5.0	5.5	V
VDD2	Low-side power supply	2.7	5.0	5.5	V

6.4 Thermal Information

THERMAL METRIC ⁽¹⁾		AMC1100		UNIT
		DUB (SOP)	DWV (SOIC)	
		8 PINS	8 PINS	
$R_{\theta JA}$	Junction-to-ambient thermal resistance	75.1	102.8	°C/W
$R_{\theta JC(top)}$	Junction-to-case (top) thermal resistance	61.6	49.8	°C/W
$R_{\theta JB}$	Junction-to-board thermal resistance	39.8	56.6	°C/W
Ψ_{JT}	Junction-to-top characterization parameter	27.2	16.0	°C/W
Ψ_{JB}	Junction-to-board characterization parameter	39.4	55.2	°C/W
$R_{\theta JC(bot)}$	Junction-to-case (bottom) thermal resistance	N/A	N/A	°C/W

(1) For more information about traditional and new thermal metrics, see the [Semiconductor and IC package thermal metrics application report](#).

6.5 Power Ratings

PARAMETER		TEST CONDITIONS	MIN	TYP	MAX	UNIT
P_D	Maximum power dissipation (both sides)	VDD1 = VDD2 = 5.5 V			82.5	mW
		VDD1 = 5.5 V, VDD2 = 3.6 V			65.6	
P_{D1}	Maximum power dissipation (high-side supply)	VDD1 = 5.5 V			44.0	mW
P_{D2}	Maximum power dissipation (low-side supply)	VDD2 = 5.5 V			38.5	mW
		VDD2 = 3.6 V			21.6	

6.6 Insulation Specifications

over operating ambient temperature range (unless otherwise noted)

PARAMETER		TEST CONDITIONS	VALUE	UNIT
GENERAL				
CLR	External clearance ⁽¹⁾	Shortest pin-to-pin distance through air, DUB package	≥ 7	mm
		Shortest pin-to-pin distance through air, DWV package	≥ 8.5	
CPG	External creepage ⁽¹⁾	Shortest pin-to-pin distance across the package surface, DUB package	≥ 7	mm
		Shortest pin-to-pin distance across the package surface, DWV package	≥ 8.5	
DTI	Distance through insulation	Minimum internal gap (internal clearance) of the insulation	≥ 0.014	mm
CTI	Comparative tracking index	DIN EN 60112 (VDE 0303-11); IEC 60112, DUB package	≥ 400	V
		DIN EN 60112 (VDE 0303-11); IEC 60112, DWV package	≥ 600	
	Material group	According to IEC 60664-1, DUB package	II	
		According to IEC 60664-1, DWV package	I	
	Overvoltage category per IEC 60664-1	Rated mains voltage ≤ 300 V _{RMS}	I-IV	
		Rated mains voltage ≤ 600 V _{RMS}	I-III	
DIN VDE V 0884-11: 2017-01⁽²⁾				
V _{IORM}	Maximum repetitive peak isolation voltage	At ac voltage (bipolar)	1200	V _{PK}
V _{IOWM}	Maximum-rated isolation working voltage	At ac voltage (sine wave)	849	V _{RMS}
		At dc voltage	1200	V _{DC}
V _{IOTM}	Maximum transient isolation voltage	V _{TEST} = V _{IOTM} , t = 60 s (qualification test)	4250	V _{PK}
		V _{TEST} = 1.2 × V _{IOTM} , t = 1 s (100% production test)	5100	
V _{IOSM}	Maximum surge isolation voltage ⁽³⁾	Test method per IEC 60065, 1.2/50-μs waveform, V _{TEST} = 1.3 × V _{IOSM} = 6000 V _{PK} (qualification)	4615	V _{PK}
q _{pd}	Apparent charge ⁽⁴⁾	Method a, after input/output safety test subgroup 2 / 3, V _{ini} = V _{IOTM} , t _{ini} = 60 s, V _{pd(m)} = 1.2 × V _{IORM} = 1440 V _{PK} , t _m = 10 s	≤ 5	pC
		Method a, after environmental tests subgroup 1, V _{ini} = V _{IOTM} , t _{ini} = 60 s, V _{pd(m)} = 1.3 × V _{IORM} = 1560 V _{PK} , t _m = 10 s	≤ 5	
		Method b1, at routine test (100% production) and preconditioning (type test), V _{ini} = V _{IOTM} , t _{ini} = 1 s, V _{pd(m)} = 1.5 × V _{IORM} = 1800 V _{PK} , t _m = 1 s	≤ 5	
C _{IO}	Barrier capacitance, input to output ⁽⁵⁾	V _{IO} = 0.5 V _{PP} at 1 MHz	1.2	pF
R _{IO}	Insulation resistance, input to output ⁽⁵⁾	V _{IO} = 500 V at T _A < 85°C	> 10 ¹²	Ω
		V _{IO} = 500 V at 85°C < T _A < 105°C	> 10 ¹¹	
		V _{IO} = 500 V at T _S = 150°C	> 10 ⁹	
	Pollution degree		2	
	Climatic category		40/125/21	
UL1577				
V _{ISO}	Withstand isolation voltage	V _{TEST} = V _{ISO} = 3005 V _{RMS} or 4250 V _{DC} , t = 60 s (qualification), V _{TEST} = 1.2 × V _{ISO} = 3606 V _{RMS} , t = 1 s (100% production test)	3005	V _{RMS}

- Apply creepage and clearance requirements according to the specific equipment isolation standards of an application. Care must be taken to maintain the creepage and clearance distance of a board design to ensure that the mounting pads of the isolator on the printed circuit board (PCB) do not reduce this distance. Creepage and clearance on a PCB become equal in certain cases. Techniques such as inserting grooves and ribs on the PCB are used to help increase these specifications.
- This coupler is suitable for *safe electrical insulation* only within the safety ratings. Compliance with the safety ratings shall be ensured by means of suitable protective circuits.
- Testing is carried out in air or oil to determine the intrinsic surge immunity of the isolation barrier.
- Apparent charge is electrical discharge caused by a partial discharge (pd).
- All pins on each side of the barrier are tied together, creating a two-pin device.

6.7 Safety-Related Certifications

VDE	UL	CSA
Certified according to DIN VDE V 0884-11: 2017-01 and DIN EN 61010-1 (VDE 0411-1) : 2011-07	Recognized under 1577 component recognition program	Recognized under CSA component acceptance NO 5 program, IEC 60950-1, and IEC 61010-1
Basic insulation	Single protection	Basic insulation
Certificate number: 40047657	File number: E181974	Certificate number: 2643952

6.8 Safety Limiting Values

Safety limiting intends to minimize potential damage to the isolation barrier upon failure of input or output circuitry.

PARAMETER		TEST CONDITIONS	MIN	TYP	MAX	UNIT
I _S	Safety input, output, or supply current	DUB package, R _{θJA} = 75.1°C/W, T _J = 150°C, T _A = 25°C, VDD1 = VDD2 = 5.5 V, see Figure 1			302	mA
		DWV package, R _{θJA} = 102.8°C/W, T _J = 150°C, T _A = 25°C, VDD1 = VDD2 = 5.5 V, see Figure 1			221	
P _S	Safety input, output, or total power ⁽¹⁾	DUB package, R _{θJA} = 75.1°C/W, T _J = 150°C, T _A = 25°C, see Figure 2			1664	mW
		DWV package, R _{θJA} = 102.8°C/W, T _J = 150°C, T _A = 25°C, see Figure 2			1216	mW
T _S	Maximum safety temperature				150	°C

- (1) The maximum safety temperature, T_S, has the same value as the maximum junction temperature, T_J, specified for the device. The I_S and P_S parameters represent the safety current and safety power, respectively. Do not exceed the maximum limits of I_S and P_S. These limits vary with the ambient temperature, T_A.

The junction-to-air thermal resistance, R_{θJA}, in the [Thermal Information](#) table is that of a device installed on a high-K test board for leaded surface-mount packages. Use these equations to calculate the value for each parameter:

$$T_J = T_A + R_{\theta JA} \times P, \text{ where } P \text{ is the power dissipated in the device.}$$

$$T_{J(max)} = T_S = T_A + R_{\theta JA} \times P_S, \text{ where } T_{J(max)} \text{ is the maximum junction temperature.}$$

$$P_S = I_S \times VDD1_{max} + I_S \times VDD2_{max}, \text{ where } VDD1_{max} \text{ is the maximum high-side supply voltage and } VDD2_{max} \text{ is the maximum low-side supply voltage.}$$

6.9 Electrical Characteristics

All minimum and maximum specifications are at $T_A = -40^\circ\text{C}$ to $+105^\circ\text{C}$ and are within the specified voltage range, unless otherwise noted. Typical values are at $T_A = +25^\circ\text{C}$, $V_{DD1} = 5\text{ V}$, and $V_{DD2} = 3.3\text{ V}$.

PARAMETER		TEST CONDITIONS	MIN	TYP	MAX	UNIT
INPUT						
	Maximum input voltage before clipping	$V_{INP} - V_{INN}$		± 320		mV
	Differential input voltage	$V_{INP} - V_{INN}$	-250		250	mV
V_{CM}	Common-mode operating range		-0.16		V_{DD1}	V
V_{OS}	Input offset voltage		-1.5	± 0.2	1.5	mV
TCV_{OS}	Input offset thermal drift		-10	± 1.5	10	$\mu\text{V}/\text{K}$
CMRR	Common-mode rejection ratio	V_{IN} from 0 V to 5 V at 0 Hz		108		dB
		V_{IN} from 0 V to 5 V at 50 kHz		95		dB
C_{IN}	Input capacitance to GND1	V_{INP} or V_{INN}		3		pF
C_{IND}	Differential input capacitance			3.6		pF
R_{IN}	Differential input resistance			28		k Ω
	Small-signal bandwidth		60	100		kHz
OUTPUT						
	Nominal gain			8		
G_{ERR}	Gain error	Initial, at $T_A = +25^\circ\text{C}$	-0.5%	$\pm 0.05\%$	0.5%	
			-1%	$\pm 0.05\%$	1%	
TCG_{ERR}	Gain error thermal drift			± 56		ppm/K
	Nonlinearity	$4.5\text{ V} \leq V_{DD2} \leq 5.5\text{ V}$	-0.075%	$\pm 0.015\%$	0.075%	
		$2.7\text{ V} \leq V_{DD2} \leq 3.6\text{ V}$	-0.1%	$\pm 0.023\%$	0.1%	
	Nonlinearity thermal drift			2.4		ppm/K
	Output noise	$V_{INP} = V_{INN} = 0\text{ V}$		3.1		mV_{RMS}
PSRR	Power-supply rejection ratio	vs V_{DD1} , 10-kHz ripple		80		dB
		vs V_{DD2} , 10-kHz ripple		61		dB
	Rise-and-fall time	0.5-V step, 10% to 90%		3.66	6.6	μs
	V_{IN} to V_{OUT} signal delay	0.5-V step, 50% to 10%, unfiltered output		1.6	3.3	μs
		0.5-V step, 50% to 50%, unfiltered output		3.15	5.6	μs
		0.5-V step, 50% to 90%, unfiltered output		5.26	9.9	μs
CMTI	Common-mode transient immunity	$V_{CM} = 1\text{ kV}$	2.5	3.75		kV/ μs
	Output common-mode voltage	$2.7\text{ V} \leq V_{DD2} \leq 3.6\text{ V}$	1.15	1.29	1.45	V
		$4.5\text{ V} \leq V_{DD2} \leq 5.5\text{ V}$	2.4	2.55	2.7	V
	Short-circuit current			20		mA
R_{OUT}	Output resistance			2.5		Ω
POWER SUPPLY						
I_{DD1}	High-side supply current			5.4	8	mA
I_{DD2}	Low-side supply current	$2.7\text{ V} < V_{DD2} < 3.6\text{ V}$		3.8	6	mA
		$4.5\text{ V} < V_{DD2} < 5.5\text{ V}$		4.4	7	mA
P_{DD1}	High-side power dissipation			27.0	44.0	mW
P_{DD2}	Low-side power dissipation	$2.7\text{ V} < V_{DD2} < 3.6\text{ V}$		11.4	21.6	mW
		$4.5\text{ V} < V_{DD2} < 5.5\text{ V}$		22.0	38.5	mW

6.10 Insulation Characteristics Curves

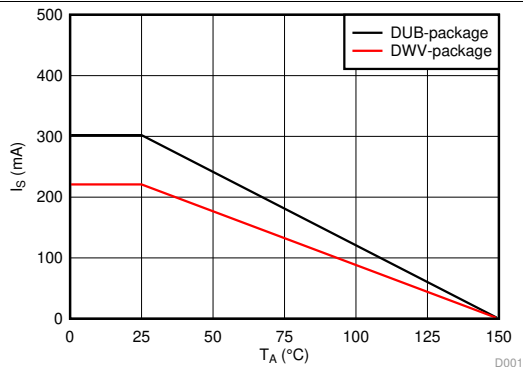

Figure 1. Thermal Derating Curve for Safety-Limiting Current per VDE

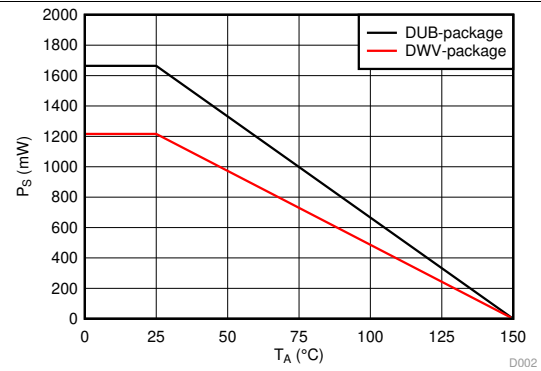

Figure 2. Thermal Derating Curve for Safety-Limiting Power per VDE

6.11 Typical Characteristics

At VDD1 = VDD2 = 5 V, VINP = -250 mV to +250 mV, and VINN = 0 V, unless otherwise noted.

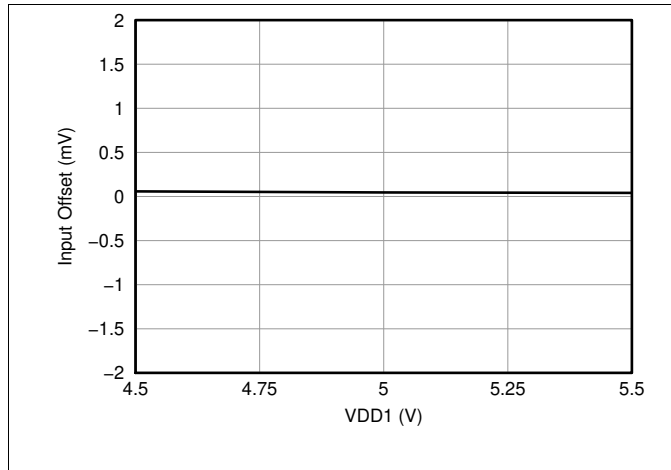

Figure 3. Input Offset vs High-Side Supply Voltage

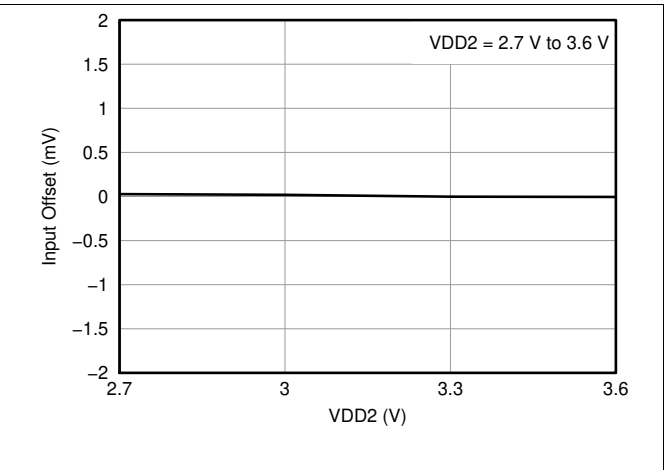

Figure 4. Input Offset vs Low-Side Supply Voltage

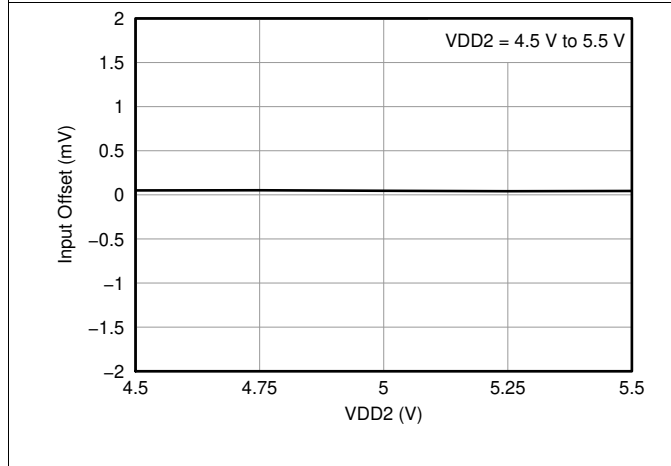

Figure 5. Input Offset vs Low-Side Supply Voltage

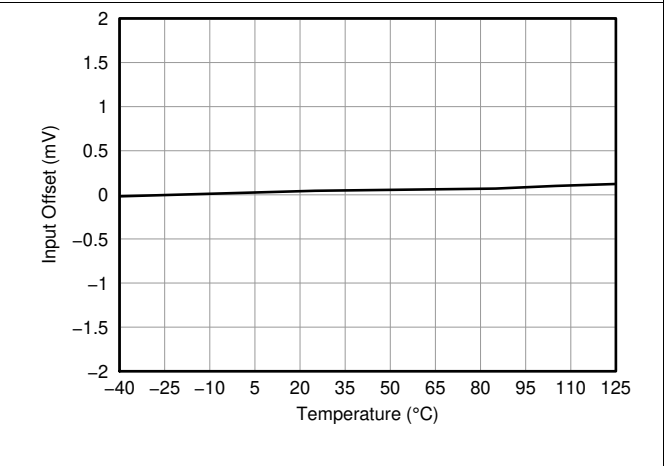

Figure 6. Input Offset vs Temperature

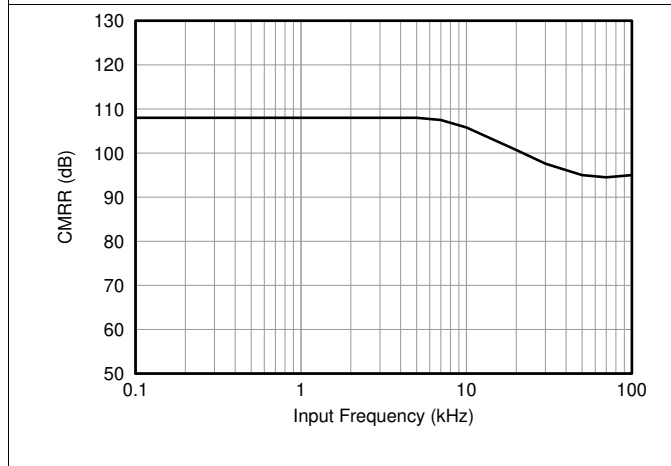

Figure 7. Common-Mode Rejection Ratio vs Input Frequency

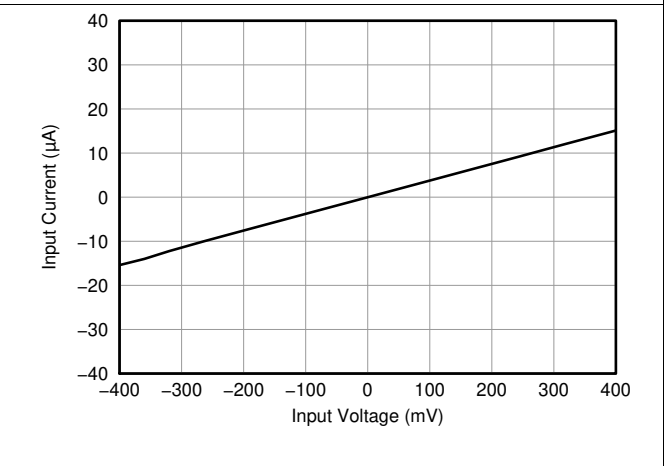
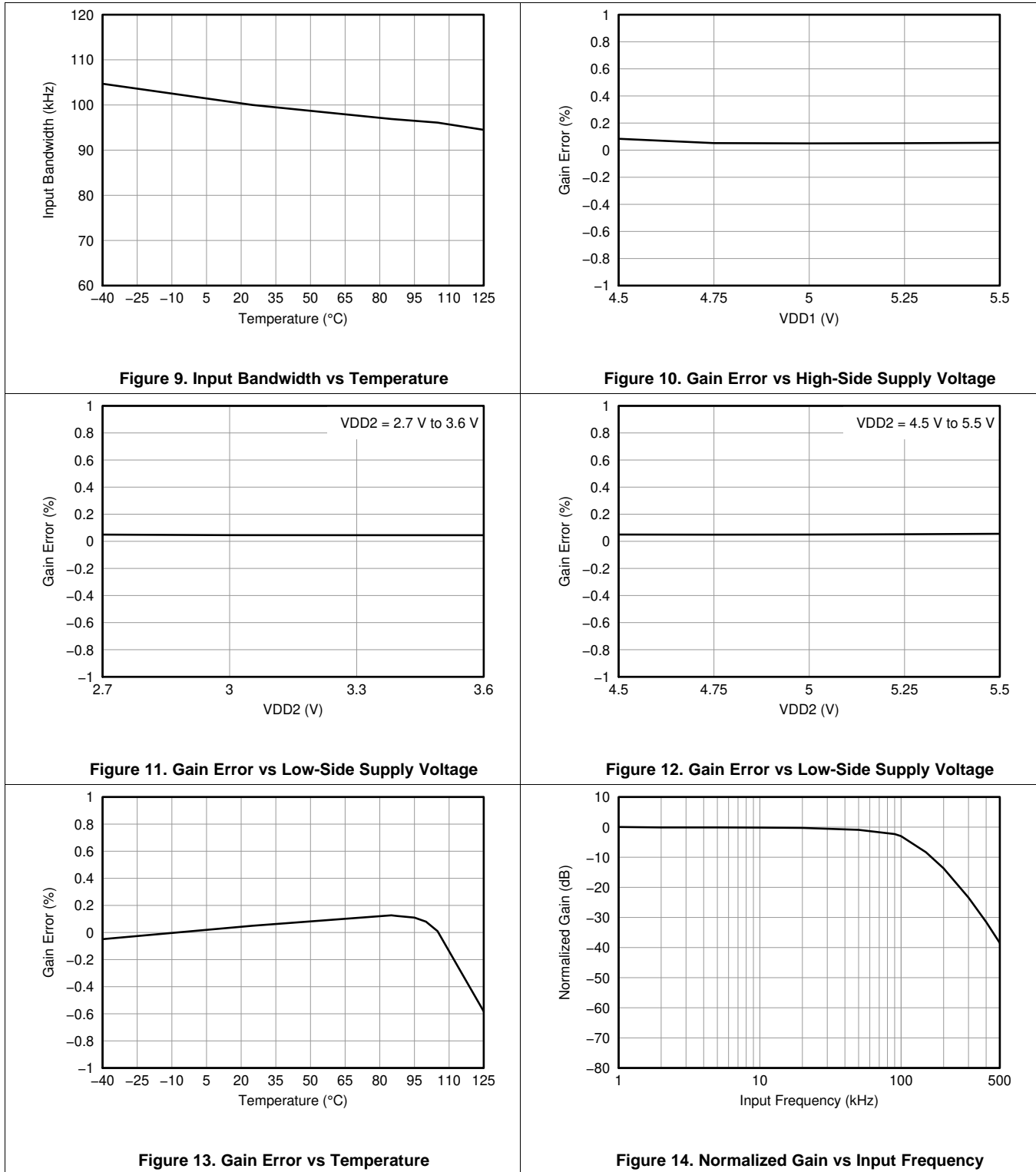

Figure 8. Input Current vs Input Voltage

Typical Characteristics (continued)

At VDD1 = VDD2 = 5 V, VINP = -250 mV to +250 mV, and VINN = 0 V, unless otherwise noted.



Typical Characteristics (continued)

At VDD1 = VDD2 = 5 V, VINP = -250 mV to +250 mV, and VINN = 0 V, unless otherwise noted.

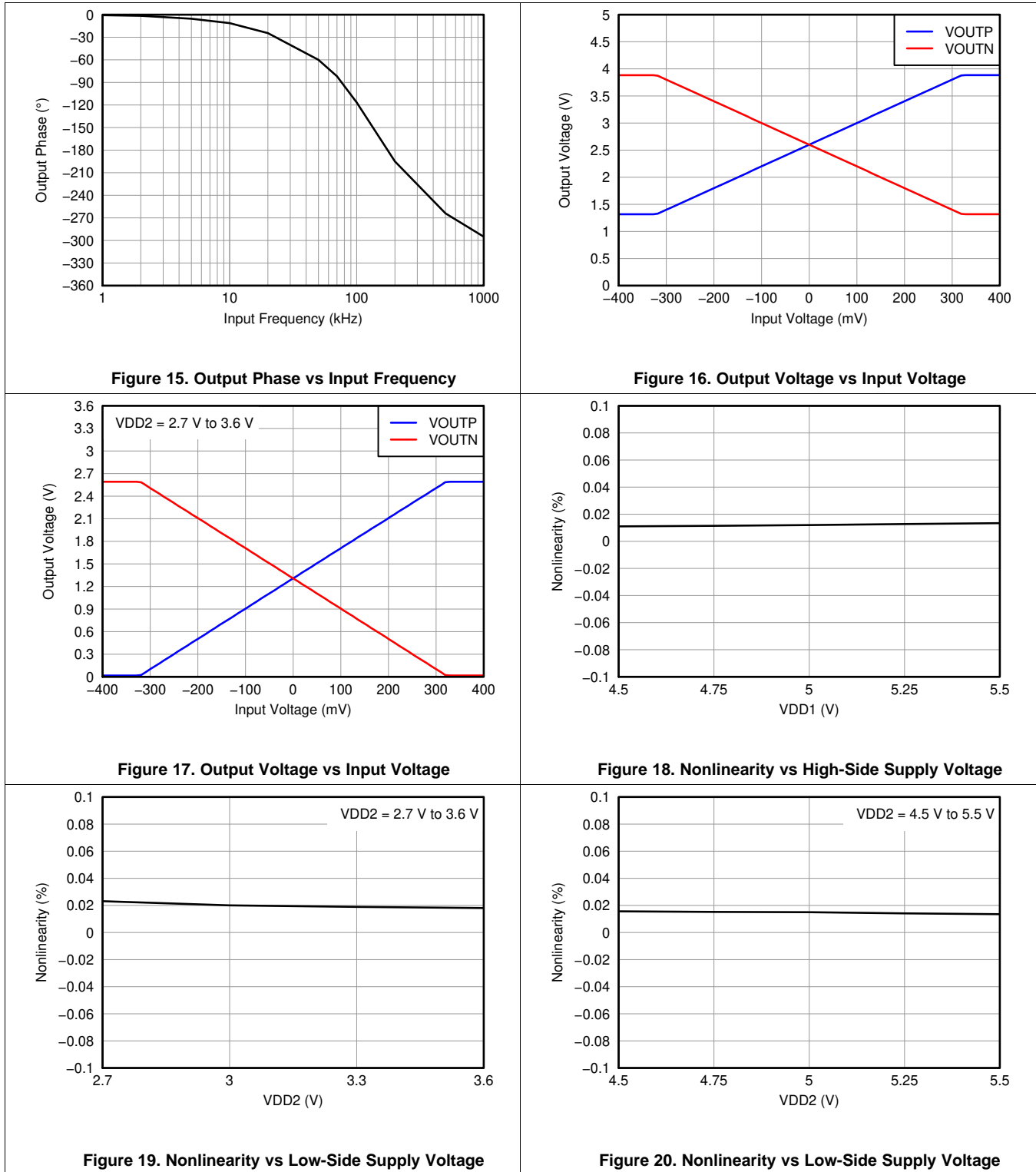

Typical Characteristics (continued)

At VDD1 = VDD2 = 5 V, VINP = -250 mV to +250 mV, and VINN = 0 V, unless otherwise noted.

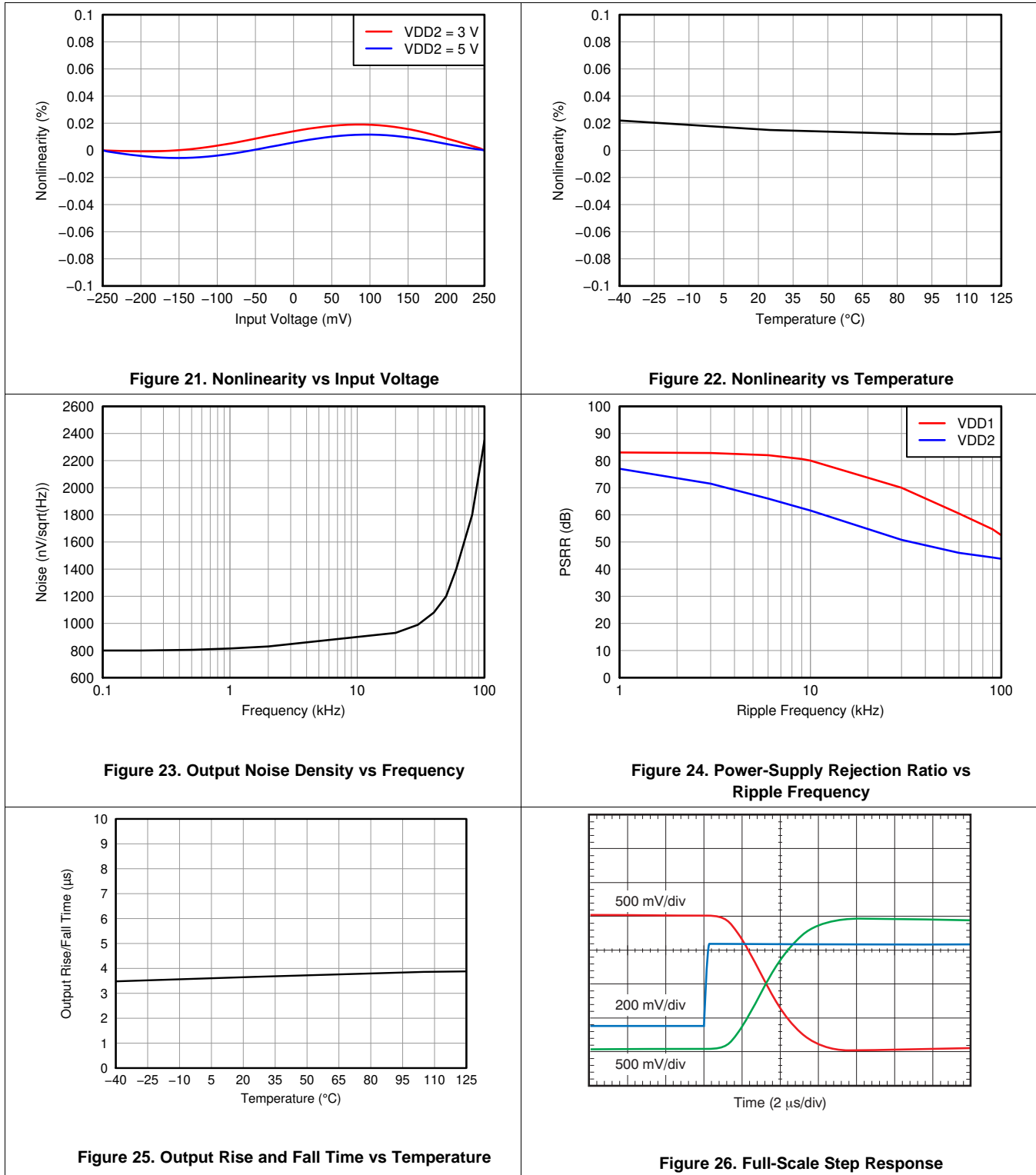

Typical Characteristics (continued)

At VDD1 = VDD2 = 5 V, VINP = -250 mV to +250 mV, and VINN = 0 V, unless otherwise noted.

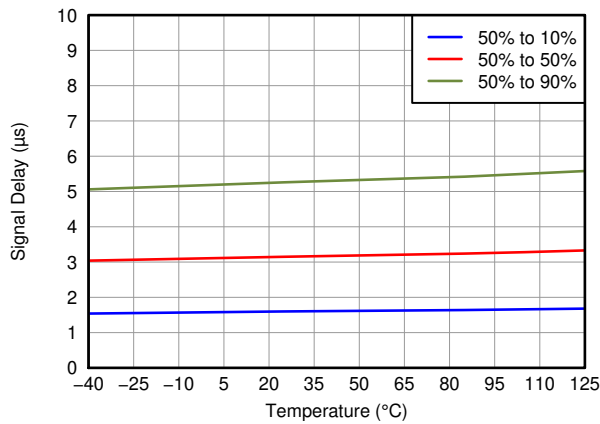

Figure 27. Output Signal Delay Time vs Temperature

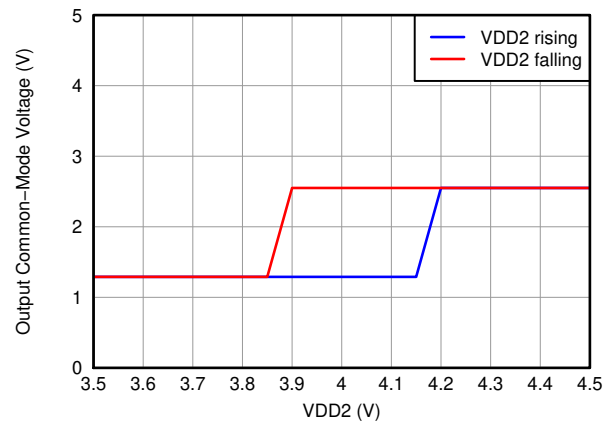

Figure 28. Output Common-Mode Voltage vs Low-Side Supply Voltage

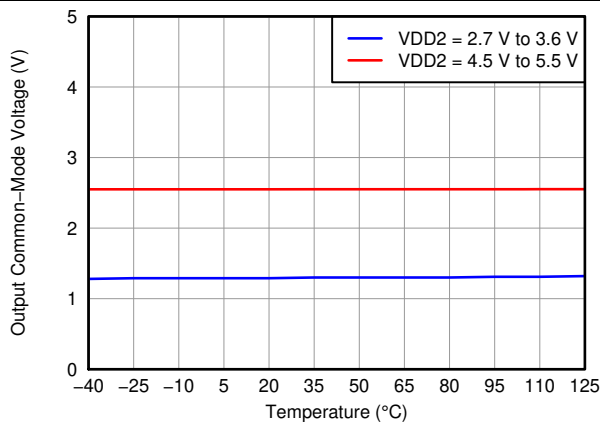

Figure 29. Output Common-Mode Voltage vs Temperature

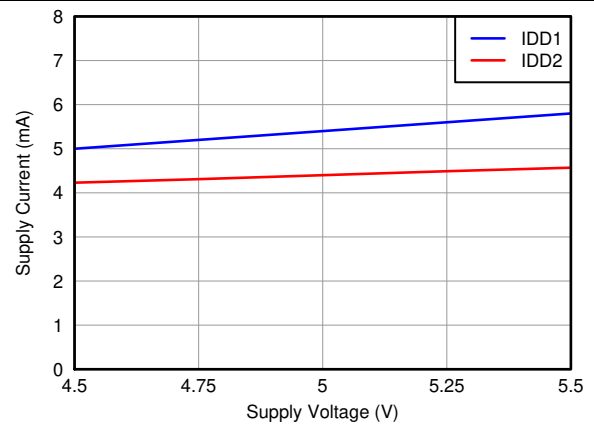

Figure 30. Supply Current vs Supply Voltage

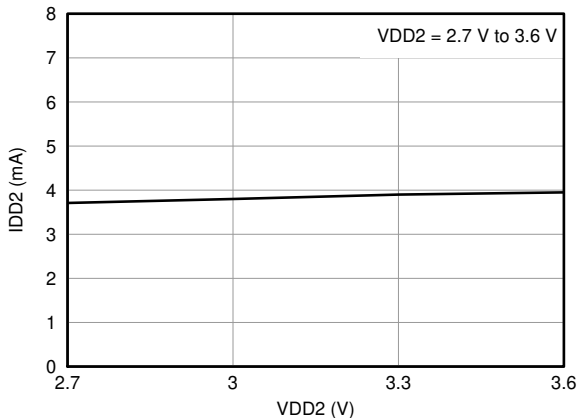

Figure 31. Low-Side Supply Current vs Low-Side Supply Voltage

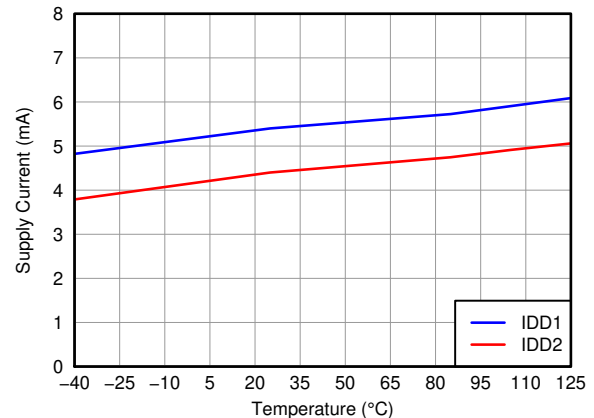

Figure 32. Supply Current vs Temperature

7 Detailed Description

7.1 Overview

The AMC1100 consists of a delta-sigma modulator input stage including an internal reference and clock generator. The output of the modulator and clock signal are differentially transmitted over the integrated capacitive isolation barrier that separates the high- and low-voltage domains. The received bitstream and clock signals are synchronized and processed by a third-order analog filter with a nominal gain of 8 on the low-side and presented as a differential output of the device, as shown in the [Functional Block Diagram](#) section.

The SiO₂-based capacitive isolation barrier supports a high level of magnetic field immunity, as described in application report [SLLA181](#), *ISO72x Digital Isolator Magnetic-Field Immunity* (available for download at www.ti.com).

7.2 Functional Block Diagram

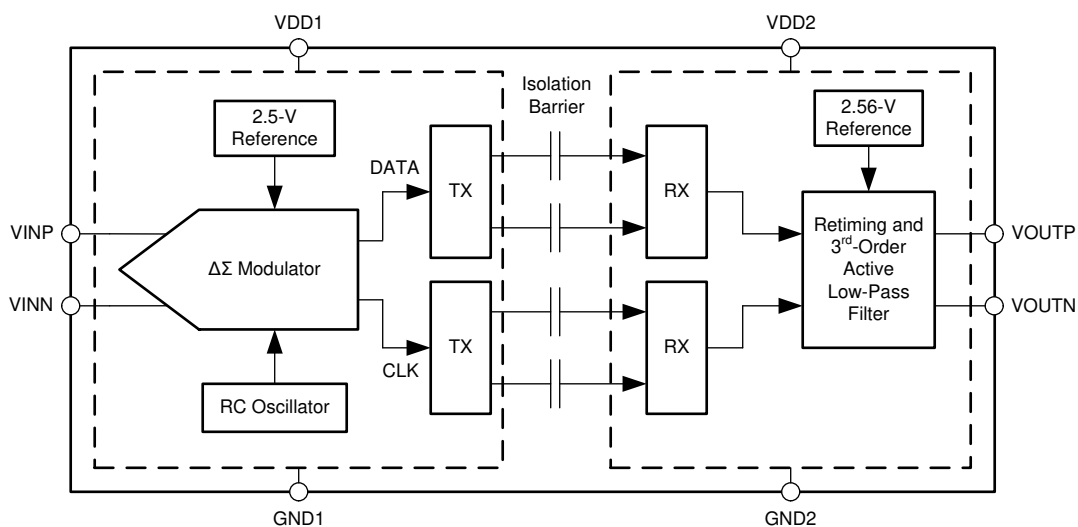

7.3 Feature Description

The differential analog input of the AMC1100 is a switched-capacitor circuit based on a second-order modulator stage that digitizes the input signal into a 1-bit output stream. The device compares the differential input signal ($V_{IN} = V_{INP} - V_{INN}$) against the internal reference of 2.5 V using internal capacitors that are continuously charged and discharged with a typical frequency of 10 MHz. With the S1 switches closed, C_{IND} charges to the voltage difference across V_{INP} and V_{INN} . For the discharge phase, both S1 switches open first and then both S2 switches close. C_{IND} discharges to approximately $GND1 + 0.8$ V during this phase. Figure 33 shows the simplified equivalent input circuitry.

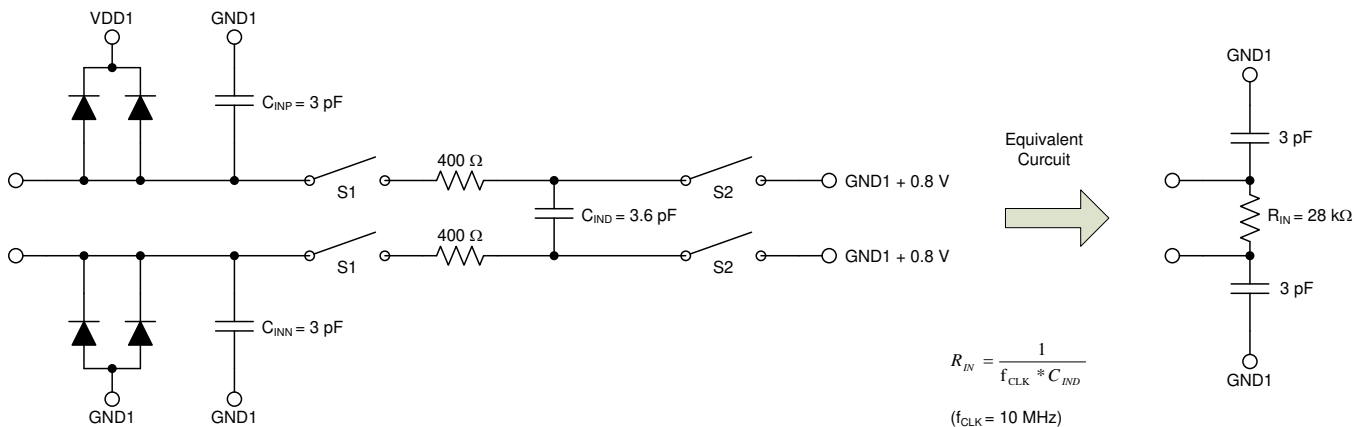

Figure 33. Equivalent Input Circuit

The analog input range is tailored to directly accommodate a voltage drop across a shunt resistor used for current sensing. However, there are two restrictions on the analog input signals, V_{INP} and V_{INN} . If the input voltage exceeds the range $GND1 - 0.5$ V to $VDD1 + 0.5$ V, the input current must be limited to 10 mA to protect the implemented input protection diodes from damage. In addition, the device linearity and noise performance are ensured only when the differential analog input voltage remains within ± 250 mV.

7.4 Device Functional Modes

The AMC1100 is powered on when the supplies are connected. The device is operated off a 5-V nominal supply on the high-side. The potential of the ground reference GND1 can be floating, which is usually the case in shunt-based current-measurement applications. TI recommends tying one side of the shunt to the GND1 pin of the AMC1100 to maintain the operating common-mode range requirements of the device.

The low-side of the AMC1100 can be powered from a supply source with a nominal voltage of 3.0 V, 3.3 V, or 5.0 V. When operated at 5 V, the common-mode voltage of the output stage is set to 2.55 V nominal; in both other cases, the common-mode voltage is automatically set to 1.29 V.

Although usually applied in shunt-based current-sensing circuits, the AMC1100 can also be used for isolated voltage measurement applications, as shown in a simplified way in Figure 34. In such applications, usually a resistor divider (R_1 and R_2 in Figure 34) is used to match the relatively small input voltage range of the AMC1100. R_2 and the AMC1100 input resistance (R_{IN}) also create a resistance divider that results in additional gain error. With the assumption that R_1 and R_{IN} have a considerably higher value than R_2 , the resulting total gain error can be estimated using Equation 1:

$$G_{ERRTOT} = G_{ERR} + \frac{R_2}{R_{IN}}$$

where:

- G_{ERR} = device gain error.

(1)

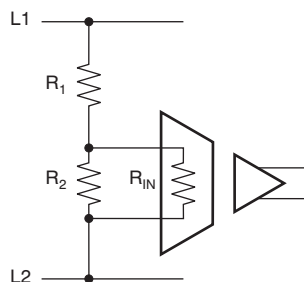

Figure 34. Voltage Measurement Application

8 Application and Implementation

NOTE

Information in the following applications sections is not part of the TI component specification, and TI does not warrant its accuracy or completeness. TI's customers are responsible for determining suitability of components for their purposes. Customers should validate and test their design implementation to confirm system functionality.

8.1 Application Information

The AMC1100 offers unique linearity, high input common-mode rejection, and low dc errors and drift. These features make the AMC1100 a robust, high-performance isolation amplifier for industrial applications where users and subsystems must be protected from high voltage potentials.

8.2 Typical Applications

8.2.1 The AMC1100 in Frequency Inverters

A typical operation for the AMC1100 is isolated current and voltage measurement in frequency inverter applications (such as industrial motor drives, photovoltaic inverters, or uninterruptible power supplies), as conceptually shown in Figure 35. Depending on the end application, only two or three phase currents are being sensed.

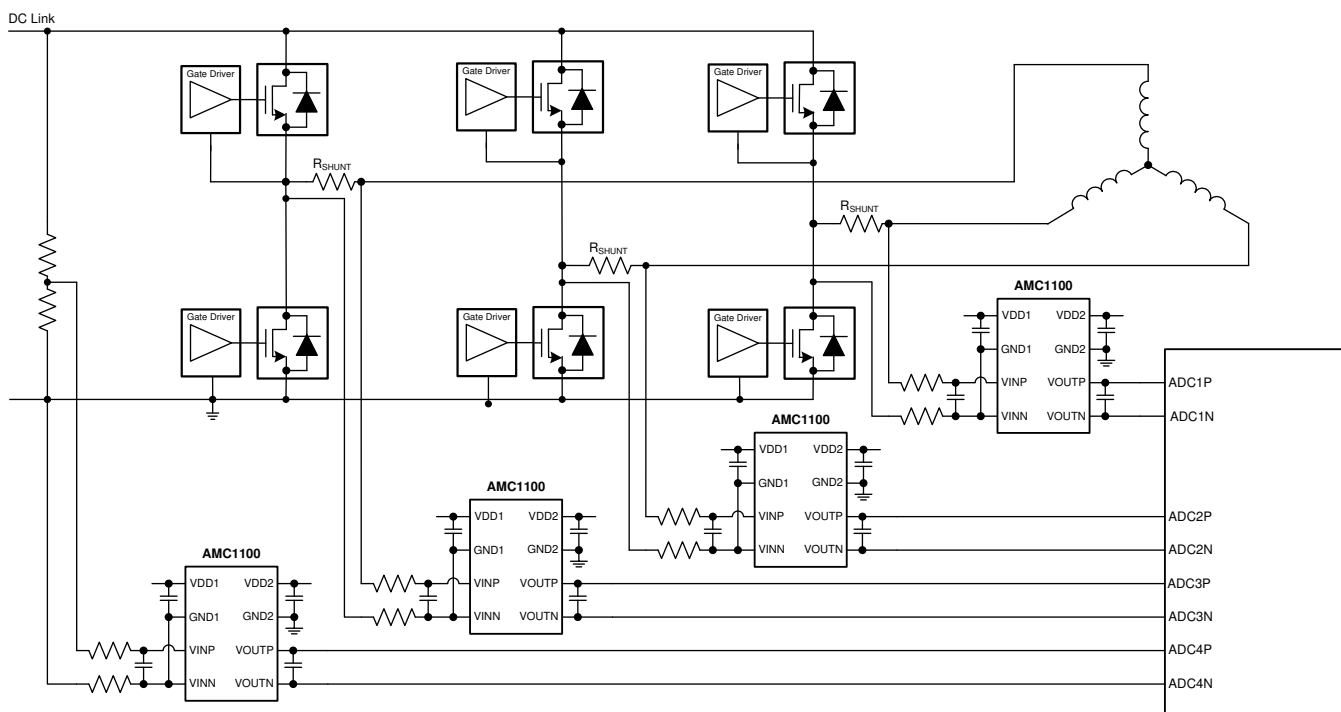

Figure 35. Isolated Current and Voltage Sensing in Frequency Inverters

8.2.1.1 Design Requirements

Current measurement through the phase of a motor power line is done via the shunt resistor R_{SHUNT} (in a two-terminal shunt); see Figure 36. For better performance, the differential signal is filtered using RC filters (components R_2 , R_3 , and C_2). Optionally, C_3 and C_4 can be used to reduce charge dumping from the inputs. In this case, care must be taken when choosing the quality of these capacitors; mismatch in values of these capacitors leads to a common-mode error at the modulator input. Using NP0 capacitors is recommended, if necessary.

Typical Applications (continued)

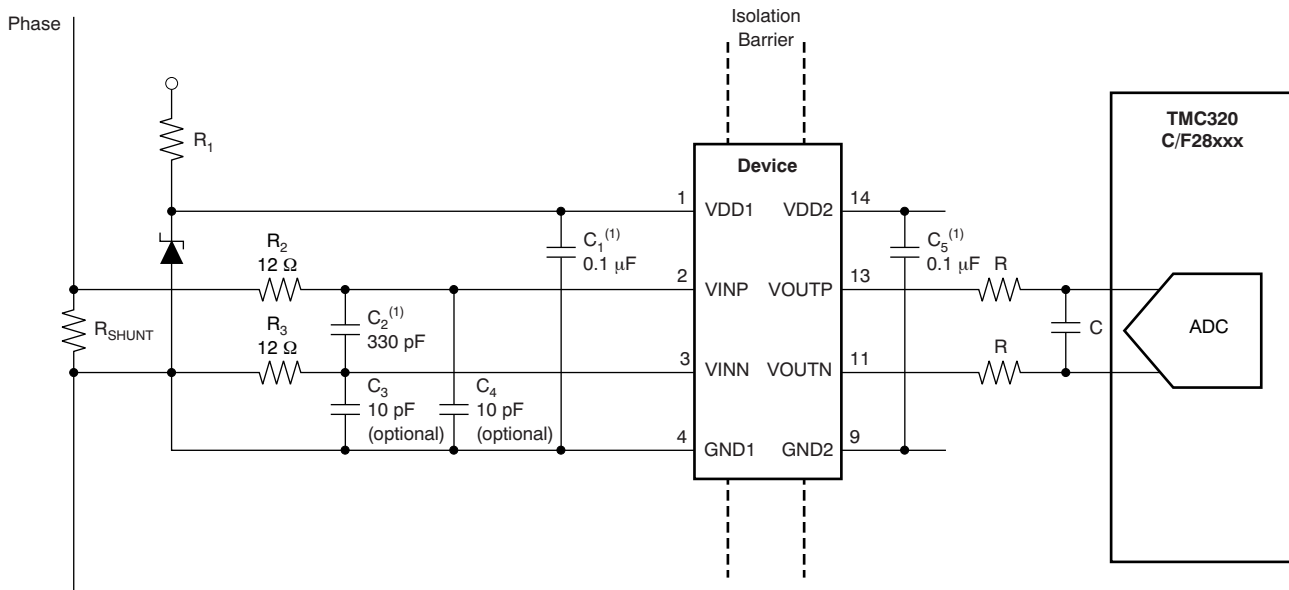

Figure 36. Shunt-Based Current Sensing with the AMC1100

The isolated voltage measurement can be performed as described in the [Device Functional Modes](#) section.

8.2.1.2 Detailed Design Procedure

The floating ground reference (GND1) is derived from the end of the shunt resistor, which is connected to the negative input of the AMC1100 (VINN). If a four-terminal shunt is used, the inputs of the AMC1100 are connected to the inner leads and GND1 is connected to one of the outer shunt leads. The differential input of the AMC1100 ensures accurate operation even in noisy environments.

The differential output of the AMC1100 can either directly drive an analog-to-digital converter (ADC) input or can be further filtered before being processed by the ADC.

8.2.1.3 Application Curve

In frequency inverter applications the power switches must be protected in case of an overcurrent condition. To allow fast powering off of the system, low delay caused by the isolation amplifier is required. [Figure 37](#) shows the typical full-scale step response of the AMC1100.

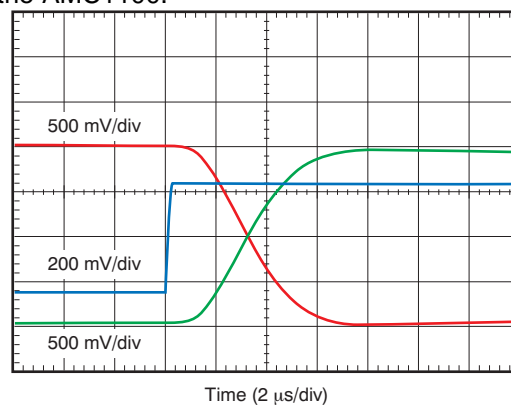

Figure 37. Typical Step Response of the AMC1100

Typical Applications (continued)

8.2.2 The AMC1100 in Energy Metering

Resulting from its immunity to magnetic fields, the AMC1100 can be used for shunt-based current sensing in smart electricity meter (e-meter) designs, as shown in Figure 38. Three AMC1100 devices are used for isolated current sensing. For voltage sensing, resistive dividers are usually used to reduce the common-mode voltage to levels that allow non-isolated measurement.

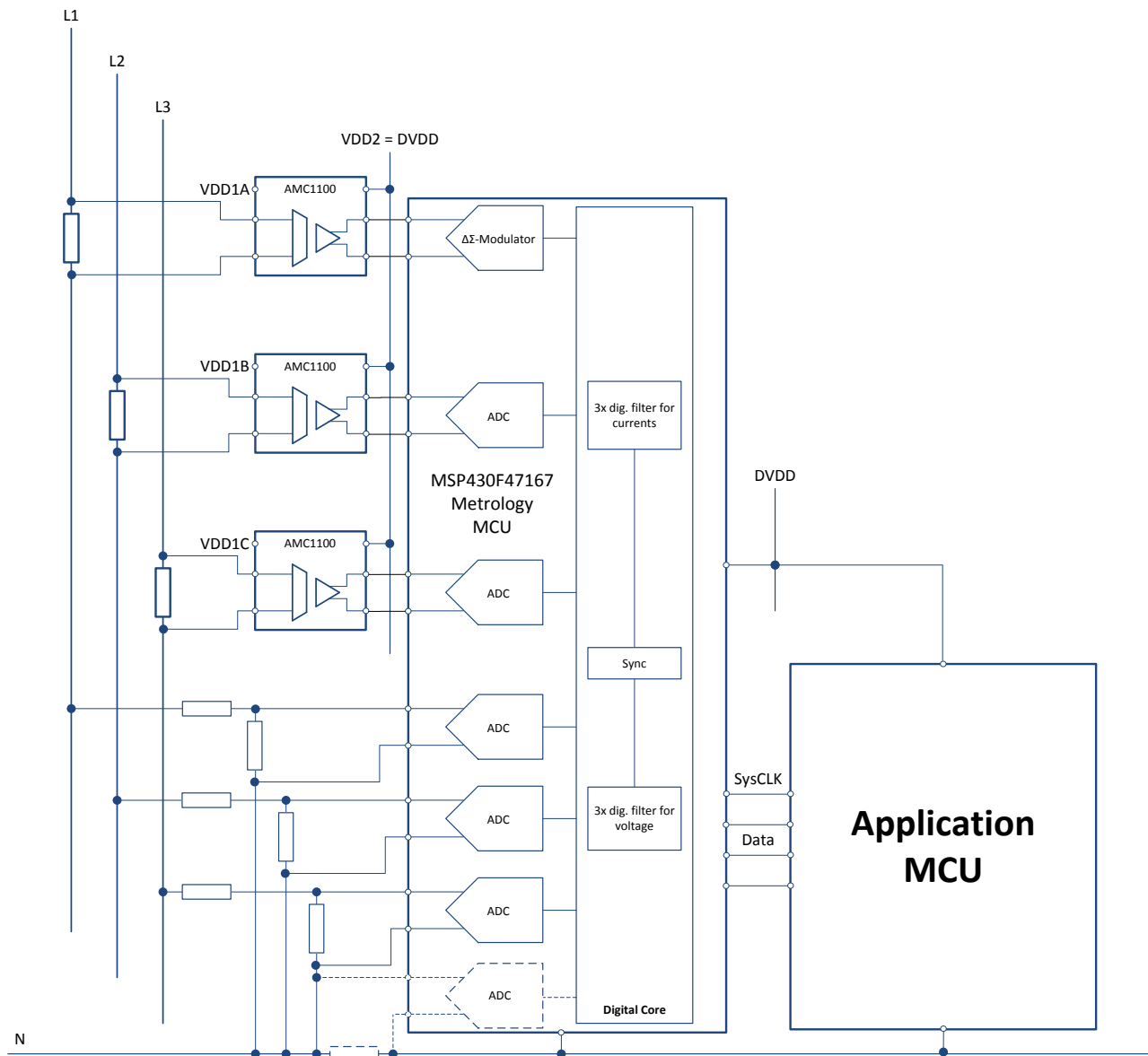

Figure 38. The AMC1100 in an E-Meter Application

8.2.2.1 Design Requirements

For best performance, an RC low-pass filter can be used in front of the AMC1100. Further improvement can be achieved by filtering the output signal of the device. In both cases, the values of the resistors and the capacitors must be tailored to the bandwidth requirements of the system.

Typical Applications (continued)

The analog output of the device is converted to the digital domain using the on-chip analog-to-digital converters (ADCs) of a suitable metrology microcontroller. The architecture of the MSP430F471x7 family of ultra-low power microcontrollers is tailored for this kind of applications. The MSP430F471x7 offers up to seven ADCs for simultaneous sampling: six of which are used for the three phase currents and voltages whereas the seventh channel can be used for additional voltage sensing of the neutral line for applications that require anti-tampering measures.

8.2.2.2 Detailed Design Procedure

The high-side supply for the AMC1100 can be derived from the phase voltage using a capacitive-drop power supply (cap-drop), as shown in Figure 39 and described in the application report SLAA552, AMC1100: Replacement of Input Main Sensing Transformer in Inverters with Isolate Amplifier.

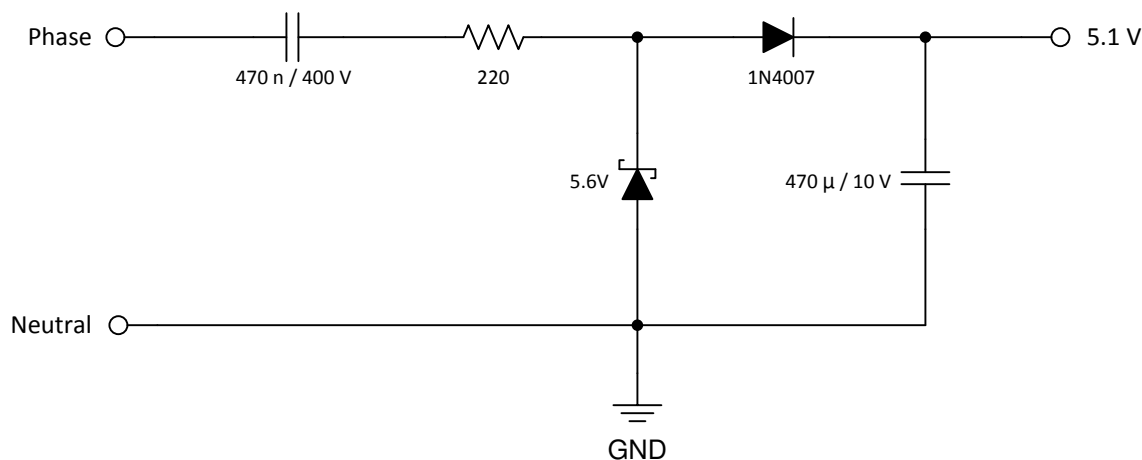

Figure 39. Cap-Drop High-Side Power Supply for the AMC1100

Alternatively, the high-side power supply for each AMC1100 can also be derived from the low-side supply using the SN6501 to drive a transformer, as proven by the TI reference design TIPD121, Isolated Current Sensing Reference Design Solution, 5A, 2kV.

8.2.2.3 Application Curve

One of the key parameters of an e-meter is its noise performance, which is mainly influenced by the performance of the ADC and the current sensor. When using a shunt-based approach, the sensor front-end consists of the actual shunt resistor and the isolated amplifier. Figure 40 shows the typical output noise density of the AMC1100 as a basis for overall performance estimations.

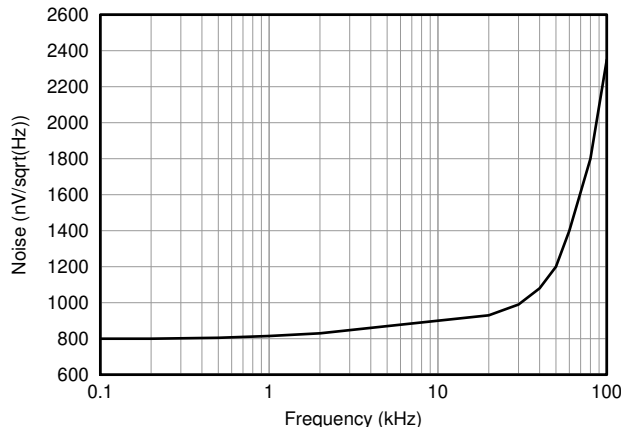

Figure 40. Output Noise Density of the AMC1100

9 Power Supply Recommendations

In a typical frequency inverter application, the high-side power supply for the AMC1100 (VDD1) is derived from the system supply, as shown in Figure 41. For lowest cost, a Zener diode can be used to limit the voltage to 5 V ± 10%. A 0.1-μF decoupling capacitor is recommended for filtering this power-supply path. Place this capacitor (C₁) as close as possible to the VDD1 pin for best performance. If better filtering is required, an additional 1-μF to 10-μF capacitor can be used.

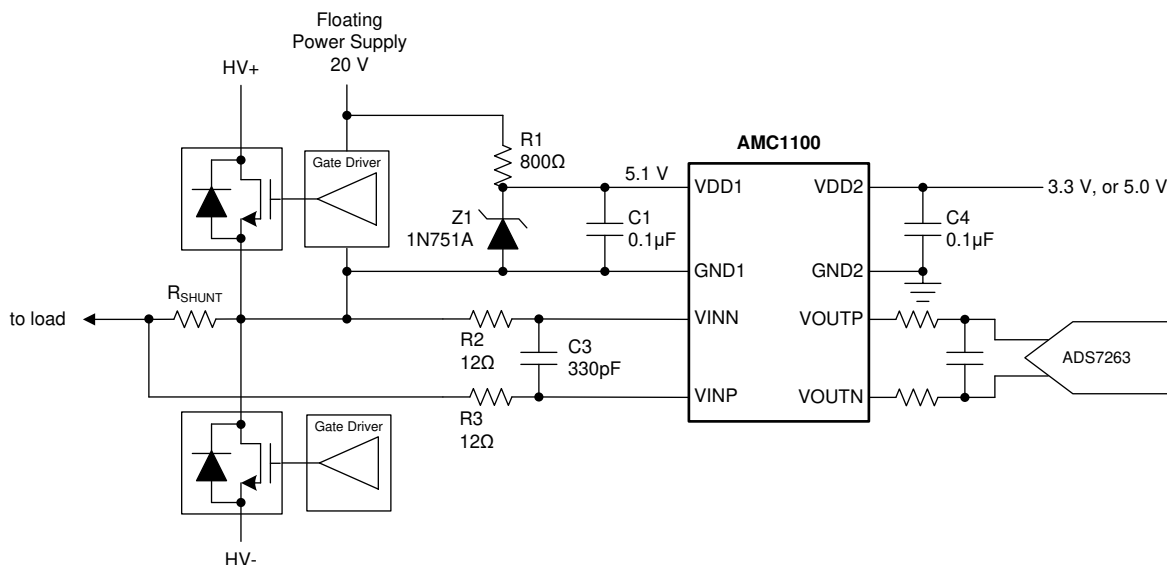

Figure 41. Zener Diode Based High-Side Supply

For higher power efficiency and better performance, a buck converter can be used; an example of such an approach is based on the LM5017. A reference design including performance test results and layout documentation can be downloaded at PMP9480, *Isolated Bias Supplies + Isolated Amplifier Combo for Line Voltage or Current Measurement*.

10 Layout

10.1 Layout Guidelines

A layout recommendation showing the critical placement of the decoupling capacitors that be placed as close as possible to the AMC1100 while maintaining a differential routing of the input signals is shown in [Figure 42](#).

To maintain the isolation barrier and the common-mode transient immunity (CMTI) of the device, keep the distance between the high-side ground (GND1) and the low-side ground (GND2) at a maximum; that is, the entire area underneath the device must be kept free of any conducting materials.

10.2 Layout Example

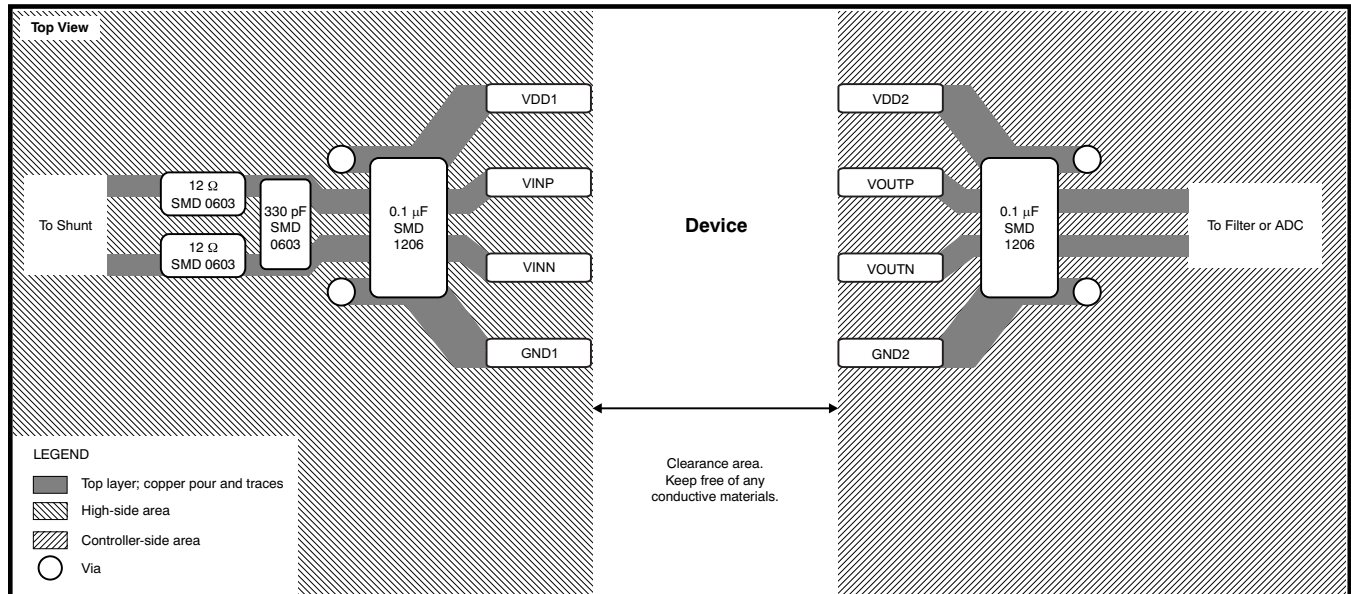

Figure 42. Example Layout

11 Device and Documentation Support

11.1 Device Support

11.1.1 Device Nomenclature

11.1.1.1 Isolation Glossary

Creepage Distance: The shortest path between two conductive input-to-output leads measured along the surface of the insulation. The shortest distance path is found around the end of the package body.

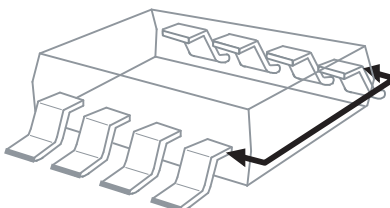

Clearance: The shortest distance between two conductive input-to-output leads measured through air (line of sight).

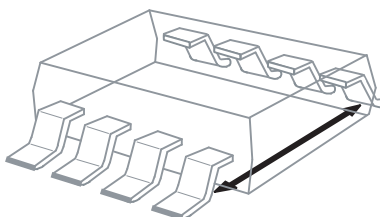

Input-to-Output Barrier Capacitance: The total capacitance between all input terminals connected together, and all output terminals connected together.

Input-to-Output Barrier Resistance: The total resistance between all input terminals connected together, and all output terminals connected together.

Primary Circuit: An internal circuit directly connected to an external supply mains or other equivalent source that supplies the primary circuit electric power.

Secondary Circuit: A circuit with no direct connection to primary power that derives its power from a separate isolated source.

Comparative Tracking Index (CTI): CTI is an index used for electrical insulating materials. It is defined as the numerical value of the voltage that causes failure by tracking during standard testing. Tracking is the process that produces a partially conducting path of localized deterioration on or through the surface of an insulating material as a result of the action of electric discharges on or close to an insulation surface. The higher CTI value of the insulating material, the smaller the minimum creepage distance.

Generally, insulation breakdown occurs either through the material, over its surface, or both. Surface failure may arise from flashover or from the progressive insulation surface degradation by small localized sparks. Such sparks result from a surface film of a conducting contaminant breaking on the insulation. The resulting break in the leakage current produces an overvoltage at the site of the discontinuity, and an electric spark is generated. These sparks often cause carbonization on insulation material and lead to a carbon track between points of different potential. This process is known as *tracking*.

11.1.1.1.1 Insulation:

Operational insulation—Insulation needed for correct equipment operation.

Basic insulation—Insulation to provide basic protection against electric shock.

Supplementary insulation—Independent insulation applied in addition to basic insulation in order to ensure protection against electric shock in the event of a failure of the basic insulation.

Device Support (continued)

Double insulation—Insulation comprising both basic and supplementary insulation.

Reinforced insulation—A single insulation system that provides a degree of protection against electric shock equivalent to double insulation.

11.1.1.1.2 Pollution Degree:

Pollution Degree 1—No pollution, or only dry, nonconductive pollution occurs. The pollution has no influence on device performance.

Pollution Degree 2—Normally, only nonconductive pollution occurs. However, a temporary conductivity caused by condensation is to be expected.

Pollution Degree 3—Conductive pollution, or dry nonconductive pollution that becomes conductive because of condensation, occurs. Condensation is to be expected.

Pollution Degree 4—Continuous conductivity occurs as a result of conductive dust, rain, or other wet conditions.

11.1.1.1.3 Installation Category:

Overvoltage Category—This section is directed at insulation coordination by identifying the transient overvoltages that may occur, and by assigning four different levels as indicated in IEC 60664.

- I. Signal Level: Special equipment or parts of equipment.
- II. Local Level: Portable equipment and so forth
- III. Distribution Level: Fixed installation.
- IV. Primary Supply Level: Overhead lines, cable systems.

Each category should be subject to smaller transients than the previous category.

11.2 Documentation Support

11.2.1 Related Documentation

Texas Instruments, [High-Voltage Lifetime of the ISO72x Family of Digital Isolators](#) application report

Texas Instruments, [ISO72x Digital Isolator Magnetic-Field Immunity](#) application report

Texas Instruments, [AMC1100: Replacement of Input Main Sensing Transformer in Inverters with Isolate Amplifier](#) application report

Texas Instruments, [Isolated Current Sensing Reference Design Solution, 5A, 2kV](#) reference guide

Texas Instruments, [PMP9480 Isolated Bias Supplies + Isolated Amplifier Combo for Line Voltage or Current Measurement](#)

Texas Instruments, [TPS6212x 15-V, 75-mA Highly Efficient Buck Converter](#) data sheet

Texas Instruments, [MSP430F471xx Mixed Signal Microcontroller](#) data sheet

Texas Instruments, [SN6501 Transformer Driver for Isolated Power Supplies](#) data sheet

Texas Instruments, [LM5017 100-V, 600-mA Constant On-Time Synchronous Buck Regulator](#) data sheet

11.3 Receiving Notification of Documentation Updates

To receive notification of documentation updates, navigate to the device product folder on ti.com. In the upper right corner, click on *Alert me* to register and receive a weekly digest of any product information that has changed. For change details, review the revision history included in any revised document.

11.4 Support Resources

TI E2E™ [support forums](#) are an engineer's go-to source for fast, verified answers and design help — straight from the experts. Search existing answers or ask your own question to get the quick design help you need.

Linked content is provided "AS IS" by the respective contributors. They do not constitute TI specifications and do not necessarily reflect TI's views; see TI's [Terms of Use](#).

11.5 Trademarks

E2E is a trademark of Texas Instruments.

All other trademarks are the property of their respective owners.

11.6 Electrostatic Discharge Caution



This integrated circuit can be damaged by ESD. Texas Instruments recommends that all integrated circuits be handled with appropriate precautions. Failure to observe proper handling and installation procedures can cause damage.

ESD damage can range from subtle performance degradation to complete device failure. Precision integrated circuits may be more susceptible to damage because very small parametric changes could cause the device not to meet its published specifications.

11.7 Glossary

[SLYZ022](#) — *TI Glossary*.

This glossary lists and explains terms, acronyms, and definitions.

12 Mechanical, Packaging, and Orderable Information

The following pages include mechanical, packaging, and orderable information. This information is the most current data available for the designated devices. This data is subject to change without notice and revision of this document. For browser-based versions of this data sheet, refer to the left-hand navigation.

PACKAGING INFORMATION

Orderable Device	Status (1)	Package Type	Package Drawing	Pins	Package Qty	Eco Plan (2)	Lead finish/ Ball material (6)	MSL Peak Temp (3)	Op Temp (°C)	Device Marking (4/5)	Samples
AMC1100DUB	ACTIVE	SOP	DUB	8	50	RoHS & Green	NIPDAU	Level-4-260C-72 HR	-40 to 105	AMC1100	Samples
AMC1100DUBR	ACTIVE	SOP	DUB	8	350	RoHS & Green	NIPDAU	Level-3-260C-168 HR	-40 to 105	AMC1100	Samples
AMC1100DWV	ACTIVE	SOIC	DWV	8	64	RoHS & Green	NIPDAU	Level-2-260C-1 YEAR	-40 to 105	AMC1100	Samples
AMC1100DWVR	ACTIVE	SOIC	DWV	8	1000	RoHS & Green	NIPDAU	Level-2-260C-1 YEAR	-40 to 105	AMC1100	Samples

(1) The marketing status values are defined as follows:

ACTIVE: Product device recommended for new designs.

LIFEBUY: TI has announced that the device will be discontinued, and a lifetime-buy period is in effect.

NRND: Not recommended for new designs. Device is in production to support existing customers, but TI does not recommend using this part in a new design.

PREVIEW: Device has been announced but is not in production. Samples may or may not be available.

OBSOLETE: TI has discontinued the production of the device.

(2) **RoHS:** TI defines "RoHS" to mean semiconductor products that are compliant with the current EU RoHS requirements for all 10 RoHS substances, including the requirement that RoHS substance do not exceed 0.1% by weight in homogeneous materials. Where designed to be soldered at high temperatures, "RoHS" products are suitable for use in specified lead-free processes. TI may reference these types of products as "Pb-Free".

RoHS Exempt: TI defines "RoHS Exempt" to mean products that contain lead but are compliant with EU RoHS pursuant to a specific EU RoHS exemption.

Green: TI defines "Green" to mean the content of Chlorine (Cl) and Bromine (Br) based flame retardants meet JS709B low halogen requirements of <=1000ppm threshold. Antimony trioxide based flame retardants must also meet the <=1000ppm threshold requirement.

(3) MSL, Peak Temp. - The Moisture Sensitivity Level rating according to the JEDEC industry standard classifications, and peak solder temperature.

(4) There may be additional marking, which relates to the logo, the lot trace code information, or the environmental category on the device.

(5) Multiple Device Markings will be inside parentheses. Only one Device Marking contained in parentheses and separated by a "-" will appear on a device. If a line is indented then it is a continuation of the previous line and the two combined represent the entire Device Marking for that device.

(6) Lead finish/Ball material - Orderable Devices may have multiple material finish options. Finish options are separated by a vertical ruled line. Lead finish/Ball material values may wrap to two lines if the finish value exceeds the maximum column width.

Important Information and Disclaimer:The information provided on this page represents TI's knowledge and belief as of the date that it is provided. TI bases its knowledge and belief on information provided by third parties, and makes no representation or warranty as to the accuracy of such information. Efforts are underway to better integrate information from third parties. TI has taken and

continues to take reasonable steps to provide representative and accurate information but may not have conducted destructive testing or chemical analysis on incoming materials and chemicals. TI and TI suppliers consider certain information to be proprietary, and thus CAS numbers and other limited information may not be available for release.

In no event shall TI's liability arising out of such information exceed the total purchase price of the TI part(s) at issue in this document sold by TI to Customer on an annual basis.

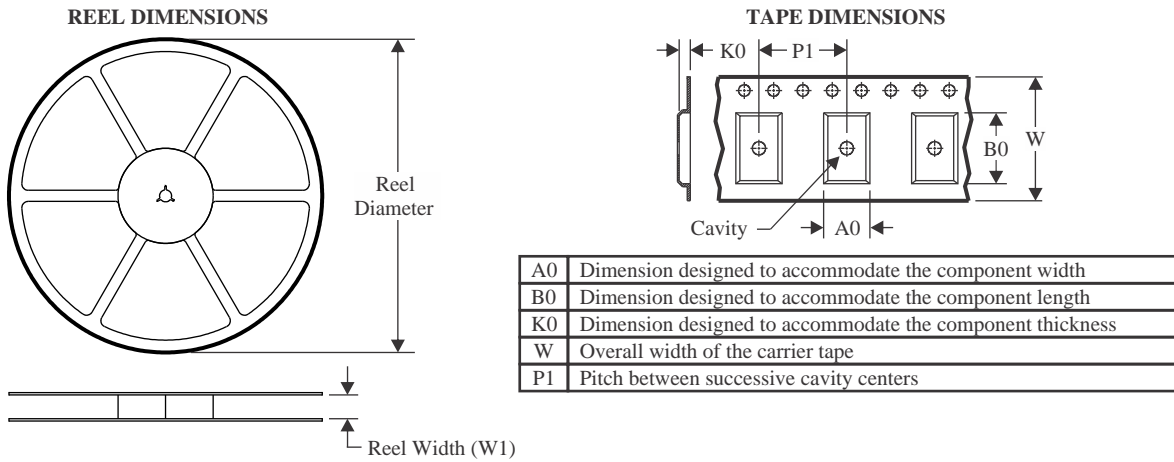
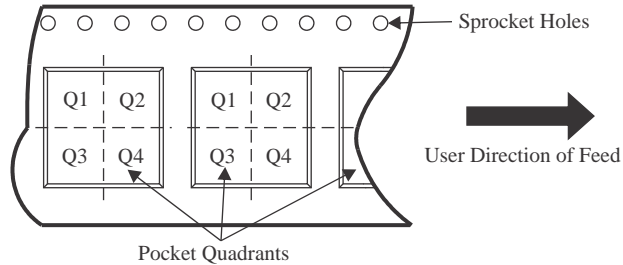
TAPE AND REEL INFORMATION

QUADRANT ASSIGNMENTS FOR PIN 1 ORIENTATION IN TAPE

*All dimensions are nominal

Device	Package Type	Package Drawing	Pins	SPQ	Reel Diameter (mm)	Reel Width W1 (mm)	A0 (mm)	B0 (mm)	K0 (mm)	P1 (mm)	W (mm)	Pin1 Quadrant
AMC1100DUBR	SOP	DUB	8	350	330.0	24.4	13.1	9.75	6.0	16.0	24.0	Q1
AMC1100DWVR	SOIC	DWV	8	1000	330.0	16.4	12.15	6.2	3.05	16.0	16.0	Q1

TAPE AND REEL BOX DIMENSIONS

*All dimensions are nominal

Device	Package Type	Package Drawing	Pins	SPQ	Length (mm)	Width (mm)	Height (mm)
AMC1100DUBR	SOP	DUB	8	350	367.0	367.0	45.0
AMC1100DWVR	SOIC	DWV	8	1000	356.0	356.0	35.0

TUBE

*All dimensions are nominal

Device	Package Name	Package Type	Pins	SPQ	L (mm)	W (mm)	T (μm)	B (mm)
AMC1100DUB	DUB	SOP	8	50	532.13	13.51	7.36	6.91
AMC1100DUB	DUB	SOP	8	50	532.13	13	7300	6.6
AMC1100DWV	DWV	SOIC	8	64	505.46	13.94	4826	6.6

GENERIC PACKAGE VIEW

DUB 8

SOP - 4.85 mm max height

SMALL OUTLINE PACKAGE

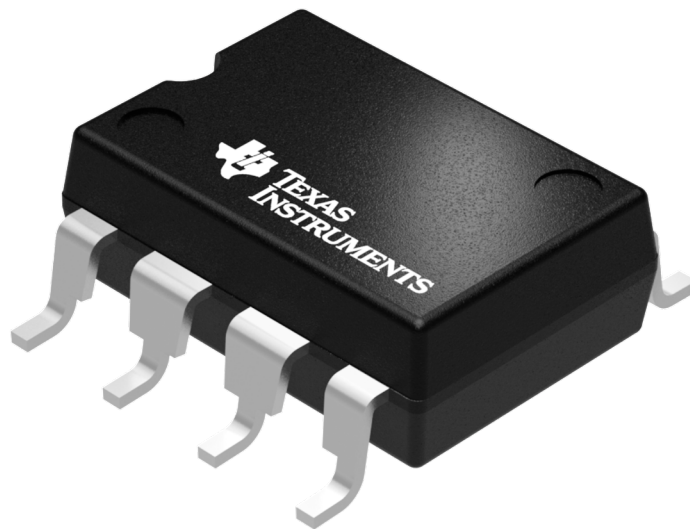

Images above are just a representation of the package family, actual package may vary.
Refer to the product data sheet for package details.

4207614/E

EXAMPLE BOARD LAYOUT

DUB0008A

SOP - 4.85 mm max height

SMALL OUTLINE PACKAGE

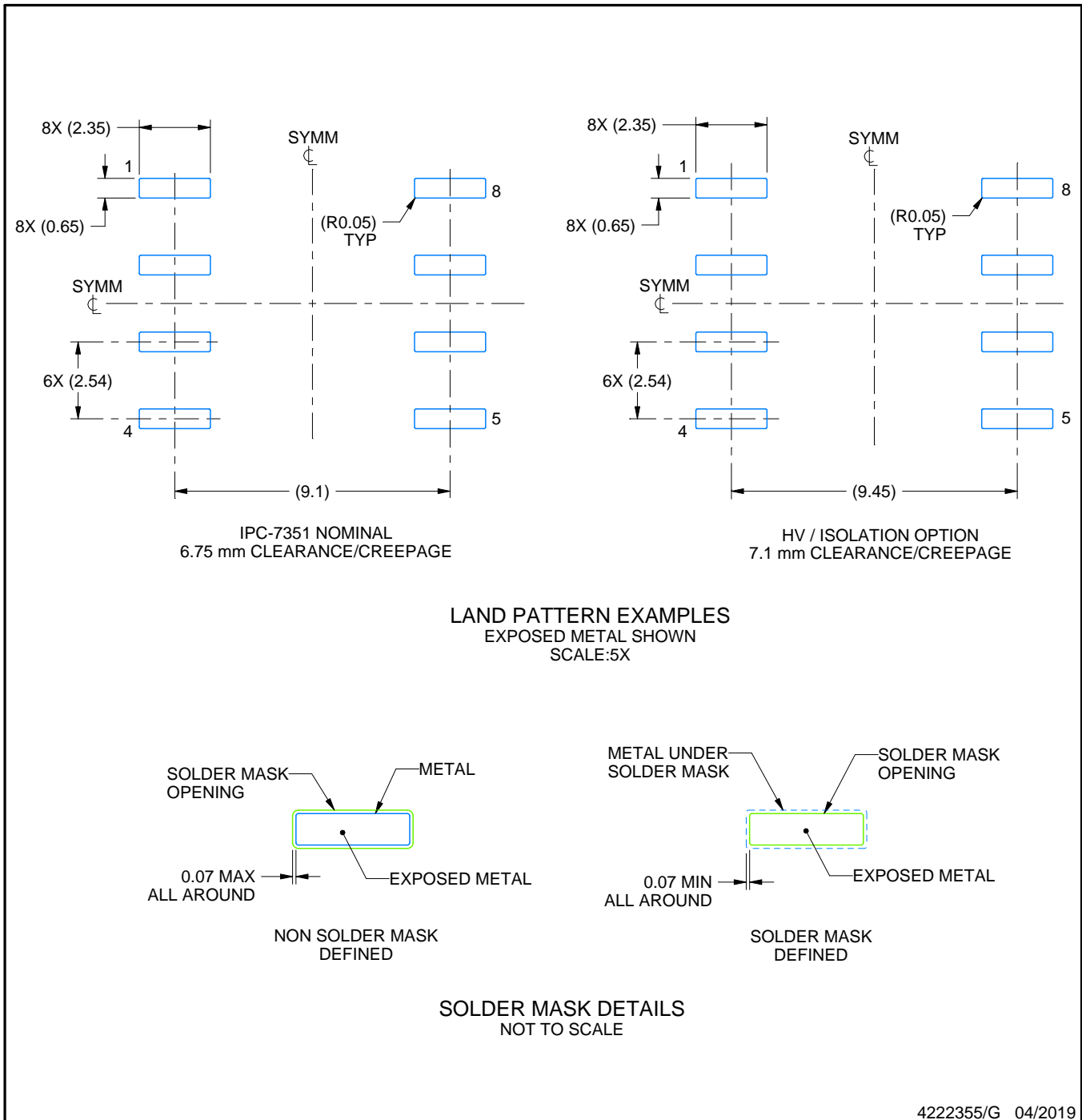

NOTES: (continued)

- Publication IPC-7351 may have alternate designs.
- Solder mask tolerances between and around signal pads can vary based on board fabrication site.

EXAMPLE STENCIL DESIGN

DUB0008A

SOP - 4.85 mm max height

SMALL OUTLINE PACKAGE

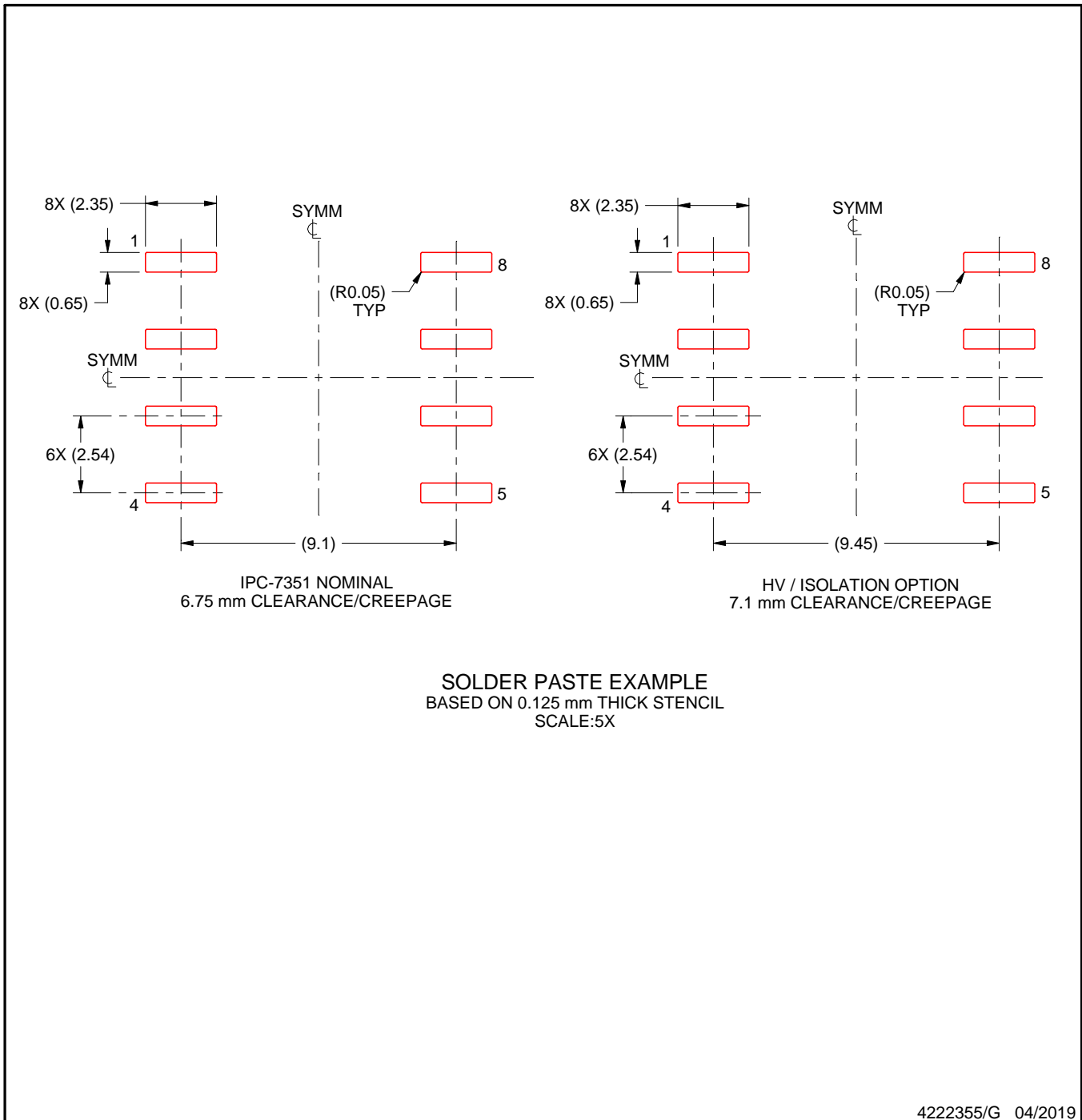

NOTES: (continued)

6. Laser cutting apertures with trapezoidal walls and rounded corners may offer better paste release. IPC-7525 may have alternate design recommendations.
7. Board assembly site may have different recommendations for stencil design.



DWV0008A

SOIC - 2.8 mm max height

SOIC

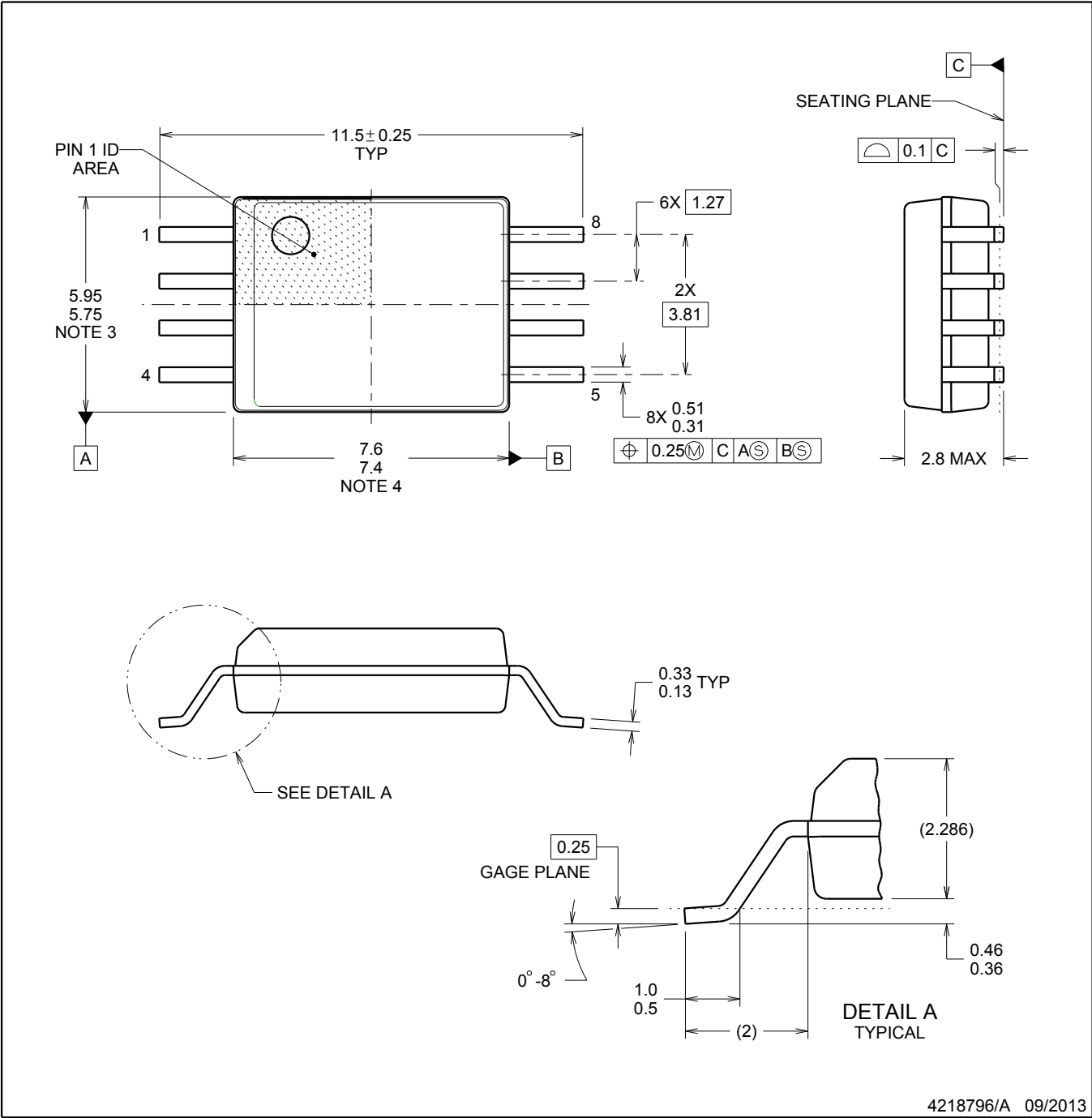

4218796/A 09/2013

NOTES:

- 1. All linear dimensions are in millimeters. Dimensions in parenthesis are for reference only. Dimensioning and tolerancing per ASME Y14.5M.
- 2. This drawing is subject to change without notice.
- 3. This dimension does not include mold flash, protrusions, or gate burrs. Mold flash, protrusions, or gate burrs shall not exceed 0.15 mm, per side.
- 4. This dimension does not include interlead flash. Interlead flash shall not exceed 0.25 mm, per side.

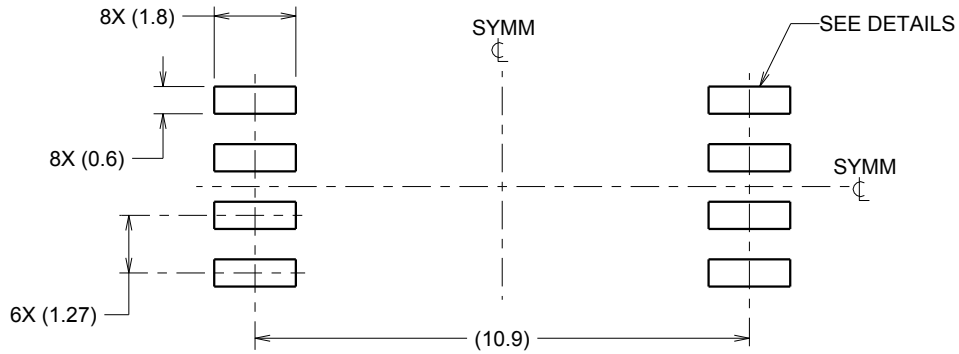

LAND PATTERN EXAMPLE
9.1 mm NOMINAL CLEARANCE/CREEPAGE
SCALE:6X

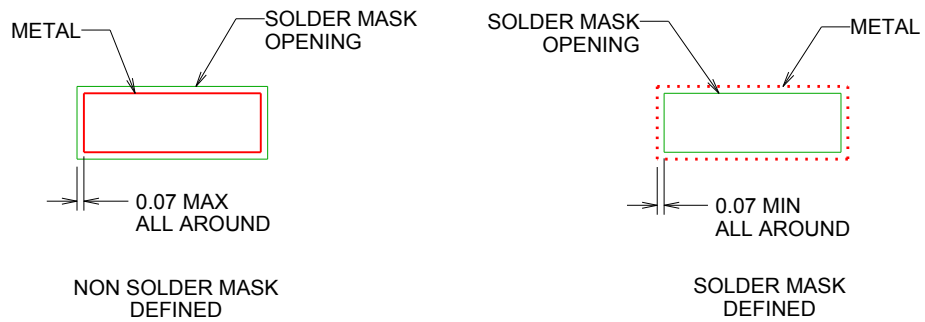

SOLDER MASK DETAILS

4218796/A 09/2013

NOTES: (continued)

- 5. Publication IPC-7351 may have alternate designs.
- 6. Solder mask tolerances between and around signal pads can vary based on board fabrication site.

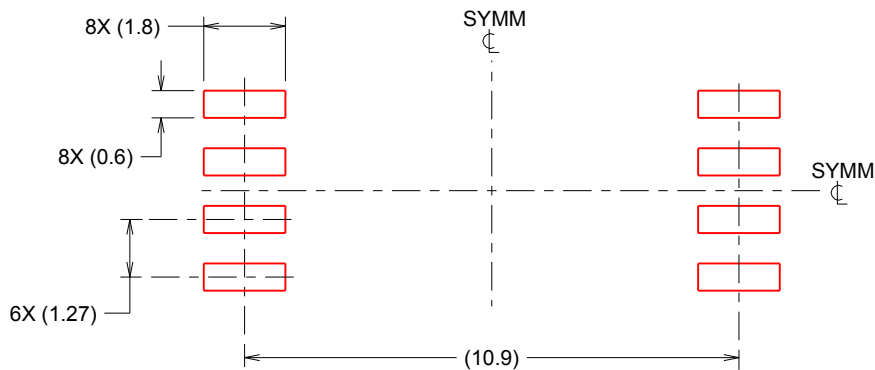

SOLDER PASTE EXAMPLE
 BASED ON 0.125 mm THICK STENCIL
 SCALE:6X

4218796/A 09/2013

NOTES: (continued)

- 7. Laser cutting apertures with trapezoidal walls and rounded corners may offer better paste release. IPC-7525 may have alternate design recommendations.
- 8. Board assembly site may have different recommendations for stencil design.

IMPORTANT NOTICE AND DISCLAIMER

TI PROVIDES TECHNICAL AND RELIABILITY DATA (INCLUDING DATA SHEETS), DESIGN RESOURCES (INCLUDING REFERENCE DESIGNS), APPLICATION OR OTHER DESIGN ADVICE, WEB TOOLS, SAFETY INFORMATION, AND OTHER RESOURCES "AS IS" AND WITH ALL FAULTS, AND DISCLAIMS ALL WARRANTIES, EXPRESS AND IMPLIED, INCLUDING WITHOUT LIMITATION ANY IMPLIED WARRANTIES OF MERCHANTABILITY, FITNESS FOR A PARTICULAR PURPOSE OR NON-INFRINGEMENT OF THIRD PARTY INTELLECTUAL PROPERTY RIGHTS.

These resources are intended for skilled developers designing with TI products. You are solely responsible for (1) selecting the appropriate TI products for your application, (2) designing, validating and testing your application, and (3) ensuring your application meets applicable standards, and any other safety, security, regulatory or other requirements.

These resources are subject to change without notice. TI grants you permission to use these resources only for development of an application that uses the TI products described in the resource. Other reproduction and display of these resources is prohibited. No license is granted to any other TI intellectual property right or to any third party intellectual property right. TI disclaims responsibility for, and you will fully indemnify TI and its representatives against, any claims, damages, costs, losses, and liabilities arising out of your use of these resources.

TI's products are provided subject to [TI's Terms of Sale](#) or other applicable terms available either on [ti.com](https://www.ti.com) or provided in conjunction with such TI products. TI's provision of these resources does not expand or otherwise alter TI's applicable warranties or warranty disclaimers for TI products.

TI objects to and rejects any additional or different terms you may have proposed.

Mailing Address: Texas Instruments, Post Office Box 655303, Dallas, Texas 75265
Copyright © 2024, Texas Instruments Incorporated

Looking for pricing, stock, or lifecycle information?

Click below to explore more details on WIN SOURCE:

 [View AMC1100DUBR](#) on WIN SOURCE

 [Texas Instruments](#) Information

Optimize Your Supply Chain with WIN SOURCE Solutions

-  Global Sourcing Solution
-  Obsolete Management
-  Cost Control Management
-  Shortage Management
-  Alternative Solution
-  Excess Inventory Management