



**THE DATASHEET OF
PCA9548ADWR**



PCA9548A Low Voltage 8-Channel I²C Switch with Reset

1 Features

- 1-of-8 Bidirectional Translating Switches
- I²C Bus and SMBus Compatible
- Active-Low Reset Input
- Three Hardware Address Pins for Use of up to Eight PCA9548A Devices on the I²C Bus
- Channel Selection Via I²C Bus
- Power-Up with All Switch Channels Deselected
- Low R_{ON} Switches
- Allows Voltage-Level Translation Between 1.8-V, 2.5-V, 3.3-V, and 5-V Buses
- No Glitch on Power Up
- Supports Hot Insertion
- Low Standby Current
- Operating Power-Supply Voltage Range of 2.3 V to 5.5 V
- 5-V Tolerant Inputs
- 0-kHz to 400-kHz Clock Frequency
- Latch-Up Performance Exceeds 100 mA Per JESD 78, Class II
- ESD Protection Exceeds JESD 22
 - 2000-V Human-Body Model (A114-A)
 - 200-V Machine Model (A115-A)
 - 1000-V Charged-Device Model (C101)

2 Applications

- Servers
- Routers (Telecom Switching Equipment)
- Factory Automation
- Products With I²C Slave Address Conflicts (for example: Multiple, Identical Temp Sensors)

3 Description

The PCA9548A device has eight bidirectional translating switches that can be controlled through the I²C bus. The SCL/SDA upstream pair fans out to eight downstream pairs, or channels. Any individual SC_x/SD_x channel or combination of channels can be selected, determined by the contents of the programmable control register. These downstream channels can be used to resolve I²C slave address conflicts. For example, if eight identical digital temperature sensors are needed in the application, one sensor can be connected at each channel: 0-7.

The system master can reset the PCA9548A in the event of a time-out or other improper operation by asserting a low in the $\overline{\text{RESET}}$ input. Similarly, the power-on reset deselected all channels and initializes the I²C/SMBus state machine. Asserting $\overline{\text{RESET}}$ causes the same reset and initialization to occur without powering down the part. This allows recovery should once of the downstream I²C buses get stuck in a low state.

The pass gates of the switches are constructed so that the V_{CC} pin can be used to limit the maximum high voltage, which is passed by the PCA9548A. This allows the use of different bus voltages on each pair, so that 1.8-V, 2.5-V or 3.3-V parts can communicate with 5-V parts, without any additional protection. External pull-up resistors pull the bus up to the desired voltage level for each channel. All I/O pins are 5-V tolerant.

Device Information⁽¹⁾

DEVICE NAME	PACKAGE	BODY SIZE (NOM)
PCA9548A	SSOP (24)	8.20 mm × 5.30 mm
	TVSOP (24)	5.00 mm × 4.40 mm
	SOIC (24)	15.40 mm × 7.50 mm
	TSSOP (24)	7.80 mm × 4.40 mm
	VQFN (24)	4.00 mm × 4.00 mm

(1) For all available packages, see the orderable addendum at the end of the datasheet.

Simplified Schematic

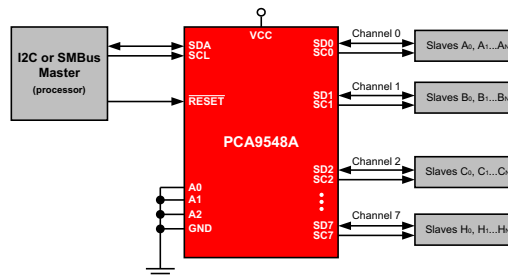

Table of Contents

1 Features	1	8.4 Device Functional Modes	14
2 Applications	1	8.5 Programming	14
3 Description	1	8.6 Register Maps	16
4 Revision History	2	9 Application and Implementation	19
5 Pin Configuration and Functions	3	9.1 Application Information	19
6 Specifications	5	9.2 Typical Application	19
6.1 Absolute Maximum Ratings	5	10 Power Supply Recommendations	23
6.2 ESD Ratings	5	10.1 Power-On Reset Errata	23
6.3 Recommended Operating Conditions	5	11 Layout	24
6.4 Thermal Information	5	11.1 Layout Guidelines	24
6.5 Electrical Characteristics	6	11.2 Layout Example	25
6.6 I ² C Interface Timing Requirements	7	12 Device and Documentation Support	26
6.7 Reset Timing Requirements	8	12.1 Related Documentation	26
6.8 Switching Characteristics	8	12.2 Receiving Notification of Documentation Updates	26
6.9 Typical Characteristics	9	12.3 Community Resources	26
7 Parameter Measurement Information	10	12.4 Trademarks	26
8 Detailed Description	12	12.5 Electrostatic Discharge Caution	26
8.1 Overview	12	12.6 Glossary	26
8.2 Functional Block Diagram	13	13 Mechanical, Packaging, and Orderable Information	26
8.3 Feature Description	14		

4 Revision History

NOTE: Page numbers for previous revisions may differ from page numbers in the current version.

Changes from Revision E (February 2015) to Revision F	Page
• Updated the <i>Description</i> section	1
• Changed the <i>Pin Configuration</i> images	3
• Updated Pin Name for Pin 8 From: SC2 To: SD2 in the <i>Pin Functions</i> table	3
• Added the <i>Typical Characteristics</i> section	9

Changes from Revision D (June 2014) to Revision E	Page
• Changed front page image	1
• Added <i>Thermal Information</i>	5
• Added <i>Layout Example</i>	25

Changes from Revision C (June 2007) to Revision D	Page
• Added $\overline{\text{RESET}}$ Errata section	14
• Updated Typical Application schematic	20
• Added Power-On Reset Errata section	23

5 Pin Configuration and Functions

**DB, DGV, DW or PW Package
24-Pin SSOP, TVSOP, SOIC or TSSOP
Top View**

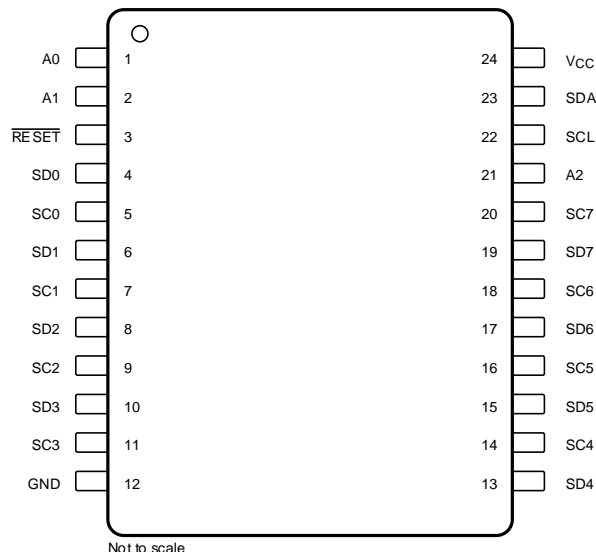

Pin Functions

PIN		I/O	DESCRIPTION
NAME	NO. DB, DW, DGV, PW		
A0	1	I	Address input 0. Connect directly to V_{CC} or ground
A1	2	I	Address input 1. Connect directly to V_{CC} or ground
$\overline{\text{RESET}}$	3	I	Active-low reset input. Connect to V_{CC} through a pull-up resistor, if not used
SD0	4	I/O	Serial data 0. Connect to V_{CC} through a pull-up resistor
SC0	5	I/O	Serial clock 0. Connect to V_{CC} through a pull-up resistor
SD1	6	I/O	Serial data 1. Connect to V_{CC} through a pull-up resistor
SC1	7	I/O	Serial clock 1. Connect to V_{CC} through a pull-up resistor
SD2	8	I/O	Serial data 2. Connect to V_{CC} through a pull-up resistor
SC2	9	I/O	Serial clock 2. Connect to V_{CC} through a pull-up resistor
SD3	10	I/O	Serial data 3. Connect to V_{CC} through a pull-up resistor
SC3	11	I/O	Serial clock 3. Connect to V_{CC} through a pull-up resistor
GND	12	—	Ground
SD4	13	I/O	Serial data 4. Connect to V_{CC} through a pull-up resistor
SC4	14	I/O	Serial clock 4. Connect to V_{CC} through a pull-up resistor
SD5	15	I/O	Serial data 5. Connect to V_{CC} through a pull-up resistor
SC5	16	I/O	Serial clock 5. Connect to V_{CC} through a pull-up resistor
SD6	17	I/O	Serial data 6. Connect to V_{CC} through a pull-up resistor
SC6	18	I/O	Serial clock 6. Connect to V_{CC} through a pull-up resistor
SD7	19	I/O	Serial data 7. Connect to V_{CC} through a pull-up resistor
SC7	20	I/O	Serial clock 7. Connect to V_{CC} through a pull-up resistor
A2	21	I	Address input 2. Connect directly to V_{CC} or ground
SCL	22	I/O	Serial clock bus. Connect to V_{CC} through a pull-up resistor
SDA	23	I/O	Serial data bus. Connect to V_{CC} through a pull-up resistor
V_{CC}	24	—	Supply voltage

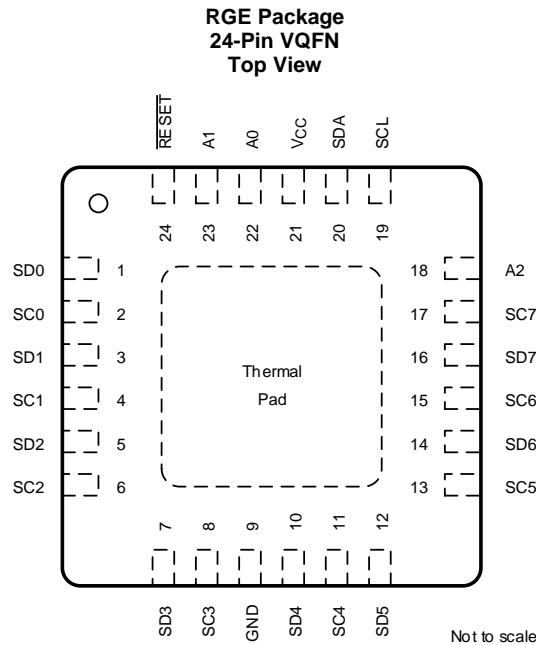

Pin Functions, RGE

PIN		I/O	DESCRIPTION
NAME	NO.		
SD0	1	I/O	Serial data 0. Connect to V _{CC} through a pull-up resistor
SC0	2	I/O	Serial clock 0. Connect to V _{CC} through a pull-up resistor
SD1	3	I/O	Serial data 1. Connect to V _{CC} through a pull-up resistor
SC1	4	I/O	Serial clock 1. Connect to V _{CC} through a pull-up resistor
SD2	5	I/O	Serial data 2. Connect to V _{CC} through a pull-up resistor
SC2	6	I/O	Serial clock 2. Connect to V _{CC} through a pull-up resistor
SD3	7	I/O	Serial data 3. Connect to V _{CC} through a pull-up resistor
SC3	8	I/O	Serial clock 3. Connect to V _{CC} through a pull-up resistor
GND	9	—	Ground
SD4	10	I/O	Serial data 4. Connect to V _{CC} through a pull-up resistor
SC4	11	I/O	Serial clock 4. Connect to V _{CC} through a pull-up resistor
SD5	12	I/O	Serial data 5. Connect to V _{CC} through a pull-up resistor
SC5	13	I/O	Serial clock 5. Connect to V _{CC} through a pull-up resistor
SD6	14	I/O	Serial data 6. Connect to V _{CC} through a pull-up resistor
SC6	15	I/O	Serial clock 6. Connect to V _{CC} through a pull-up resistor
SD7	16	I/O	Serial data 7. Connect to V _{CC} through a pull-up resistor
SC7	17	I/O	Serial clock 7. Connect to V _{CC} through a pull-up resistor
A2	18	I	Address input 2. Connect directly to V _{CC} or ground
SCL	19	I/O	Serial clock bus. Connect to V _{CC} through a pull-up resistor
SDA	20	I/O	Serial data bus. Connect to V _{CC} through a pull-up resistor
V _{CC}	21	—	Supply voltage
A0	22	I	Address input 0. Connect directly to V _{CC} or ground
A1	23	I	Address input 1. Connect directly to V _{CC} or ground
RESET	24	I	Active-low reset input. Connect to V _{CC} through a pull-up resistor, if not used

6 Specifications

6.1 Absolute Maximum Ratings⁽¹⁾

over operating free-air temperature range (unless otherwise noted)

		MIN	MAX	UNIT
V _{CC}	Supply voltage	-0.5	7	V
V _I	Input voltage ⁽²⁾	-0.5	7	V
I _I	Input current	-20	20	mA
I _O	Output current	-25	25	mA
I _{CC}	Supply current	-100	100	mA
T _{stg}	Storage temperature	-65	150	°C

- (1) Stresses beyond those listed under *Absolute Maximum Ratings* may cause permanent damage to the device. These are stress ratings only, which do not imply functional operation of the device at these or any other conditions beyond those indicated under *Recommended Operating Conditions*. Exposure to absolute-maximum-rated conditions for extended periods may affect device reliability.
- (2) The input negative-voltage and output voltage ratings may be exceeded if the input and output current ratings are observed.

6.2 ESD Ratings

		VALUE	UNIT
V _(ESD)	Electrostatic discharge	Human body model (HBM), per ANSI/ESDA/JEDEC JS-001 ⁽¹⁾	±2000
		Charged-device model (CDM), per JEDEC specification JESD22-C101 or ANSI/ESDA/JEDEC JS-002 ⁽²⁾	±1000

- (1) JEDEC document JEP155 states that 500-V HBM allows safe manufacturing with a standard ESD control process.
- (2) JEDEC document JEP157 states that 250-V CDM allows safe manufacturing with a standard ESD control process.

6.3 Recommended Operating Conditions⁽¹⁾

			MIN	MAX	UNIT
V _{CC}	Supply voltage		2.3	5.5	V
V _{IH}	High-level input voltage	SCL, SDA	0.7 × V _{CC}	6	V
		A2–A0, $\overline{\text{RESET}}$	0.7 × V _{CC}	V _{CC} + 0.5	
V _{IL}	Low-level input voltage	SCL, SDA	-0.5	0.3 × V _{CC}	V
		A2–A0, $\overline{\text{RESET}}$	-0.5	0.3 × V _{CC}	
T _A	Operating free-air temperature		-40	85	°C

- (1) All unused control inputs of the device must be held at V_{CC} or GND to ensure proper device operation. See the *Implications of Slow or Floating CMOS Inputs* application report.

6.4 Thermal Information

THERMAL METRIC ⁽¹⁾	PCA9548A					UNIT	
	DB (SSOP)	DGV (TVSOP)	DW (SOIC)	PW (TSSOP)	RGE (VQFN)		
	24 PINS						
R _{θJA}	Junction-to-ambient thermal resistance	89.1	99.6	73.2	100.6	49.5	°C/W
R _{θJC(top)}	Junction-to-case (top) thermal resistance	51.1	31.1	41.3	46.2	53.2	°C/W
R _{θJB}	Junction-to-board thermal resistance	46.6	53.1	42.9	54.5	26.4	°C/W
ψ _{JT}	Junction-to-top characterization parameter	18.5	0.9	15.3	6.8	1.7	°C/W
ψ _{JB}	Junction-to-board characterization parameter	46.3	52.6	42.6	54	26.4	°C/W
R _{θJC(bot)}	Junction-to-case (bottom) thermal resistance	N/A	N/A	N/A	N/A	8.5	°C/W

- (1) For more information about traditional and new thermal metrics, see the *Semiconductor and IC Package Thermal Metrics* application report.

6.5 Electrical Characteristics

 $V_{CC} = 2.3\text{ V to }3.6\text{ V}$, over recommended operating free-air temperature range (unless otherwise noted)

PARAMETER		TEST CONDITIONS	V_{CC}	MIN	TYP ⁽¹⁾	MAX	UNIT
V_{POR}	Power-on reset voltage ⁽²⁾	No load, $V_I = V_{CC}$ or GND	V_{POR}	1.6	2.1		V
$V_{O(sw)}$	Switch output voltage	$V_{I(sw)} = V_{CC}$, $I_{SWout} = -100\ \mu\text{A}$	5 V	3.6			V
			4.5 V to 5.5 V	2.6	4.5		
			3.3 V	1.9			
			3 V to 3.6 V	1.6	2.8		
			2.5 V	1.5			
I_{OL}	SDA	$V_{OL} = 0.4\text{ V}$	2.3 V to 5.5 V	3	6	mA	
		$V_{OL} = 0.6\text{ V}$		6	9		
I_I	SCL, SDA	$V_I = V_{CC}$ or GND	2.3 V to 5.5 V	-1	1	μA	
	SC7–SC0, SD7–SD0			-1	1		
	A2–A0			-1	1		
	RESET			-1	1		
I_{CC}	Operating mode	$f_{SCL} = 400\text{ kHz}$	5.5 V	50	80	μA	
			3.6 V	20	35		
			2.7 V	11	20		
		$f_{SCL} = 100\text{ kHz}$	5.5 V	9	30		
			3.6 V	6	15		
			2.7 V	4	8		
	Standby mode	Low inputs	$V_I = \text{GND}$, $I_O = 0$	5.5 V	0.2		1
				3.6 V	0.1		1
		High inputs		5.5 V	0.2		1
				3.6 V	0.1		1
ΔI_{CC}	Supply-current change	SCL, SDA	2.3 V to 5.5 V	SCL or SDA input at 0.6 V, Other inputs at V_{CC} or GND		3	20
				SCL or SDA input at $V_{CC} - 0.6\text{ V}$, Other inputs at V_{CC} or GND		3	20
C_i	A2–A0	$V_I = V_{CC}$ or GND	2.3 V to 5.5 V	4	5	pF	
	RESET			4	5		
	SCL			20	28		
$C_{iO(off)}$ ⁽³⁾	SDA	$V_I = V_{CC}$ or GND, Switch OFF	2.3 V to 5.5 V	20	28	pF	
	SC7–SC0, SD7–SD0			5.5	7.5		
R_{ON}	Switch-on resistance	$V_O = 0.4\text{ V}$, $I_O = 15\text{ mA}$	4.5 V to 5.5 V	4	10	20	Ω
			3 V to 3.6 V	5	12	30	
			2.3 V to 2.7 V	7	15	45	

(1) All typical values are at nominal supply voltage (2.5-, 3.3-, or 5-V V_{CC}), $T_A = 25^\circ\text{C}$.

(2) The power-on reset circuit resets the I²C bus logic with $V_{CC} < V_{POR}$. V_{CC} must be lowered to 0.2 V to reset the device.

(3) $C_{iO(ON)}$ depends on internal capacitance and external capacitance added to the SCn lines when channel(s) are ON.

6.6 I²C Interface Timing Requirements

over recommended operating free-air temperature range (unless otherwise noted) (see [Figure 3](#))

		MIN	MAX	UNIT
STANDARD MODE				
f _{scl}	I ² C clock frequency	0	100	kHz
t _{sch}	I ² C clock high time	4		μs
t _{scl}	I ² C clock low time	4.7		μs
t _{sp}	I ² C spike time		50	ns
t _{sds}	I ² C serial-data setup time	250		ns
t _{sdh}	I ² C serial-data hold time	0 ⁽¹⁾		μs
t _{icr}	I ² C input rise time		1000	ns
t _{icf}	I ² C input fall time		300	ns
t _{ocf}	I ² C output (SDn) fall time (10-pF to 400-pF bus)		300	ns
t _{buf}	I ² C bus free time between stop and start	4.7		μs
t _{sts}	I ² C start or repeated start condition setup	4.7		μs
t _{sth}	I ² C start or repeated start condition hold	4		μs
t _{sps}	I ² C stop condition setup	4		μs
t _{vdL(Data)}	Valid-data time (high to low) ⁽²⁾	SCL low to SDA output low valid		1
t _{vdH(Data)}	Valid-data time (low to high) ⁽²⁾	SCL low to SDA output high valid		0.6
t _{vd(ack)}	Valid-data time of ACK condition	ACK signal from SCL low to SDA output low		1
C _b	I ² C bus capacitive load		400	pF
FAST MODE				
f _{scl}	I ² C clock frequency	0	400	kHz
t _{sch}	I ² C clock high time	0.6		μs
t _{scl}	I ² C clock low time	1.3		μs
t _{sp}	I ² C spike time		50	ns
t _{sds}	I ² C serial-data setup time	100		ns
t _{sdh}	I ² C serial-data hold time	0 ⁽¹⁾		μs
t _{icr}	I ² C input rise time	20 + 0.1C _{b(3)}	300	ns
t _{icf}	I ² C input fall time	20 + 0.1C _{b(3)}	300	ns
t _{ocf}	I ² C output (SDn) fall time (10-pF to 400-pF bus)	20 + 0.1C _{b(3)}	300	ns
t _{buf}	I ² C bus free time between stop and start	1.3		μs
t _{sts}	I ² C start or repeated start condition setup	0.6		μs
t _{sth}	I ² C start or repeated start condition hold	0.6		μs
t _{sps}	I ² C stop condition setup	0.6		μs
t _{vdL(Data)}	Valid-data time (high to low) ⁽²⁾	SCL low to SDA output low valid		1
t _{vdH(Data)}	Valid-data time (low to high) ⁽²⁾	SCL low to SDA output high valid		0.6
t _{vd(ack)}	Valid-data time of ACK condition	ACK signal from SCL low to SDA output low		1
C _b	I ² C bus capacitive load		400	pF

- (1) A device internally must provide a hold time of at least 300 ns for the SDA signal (referred to the V_{IH} min of the SCL signal), to bridge the undefined region of the falling edge of SCL.
- (2) Data taken using a 1-kΩ pull-up resistor and 50-pF load (see [Figure 4](#)).
- (3) C_b = total bus capacitance of one bus line in pF.

6.7 Reset Timing Requirements

over recommended operating free-air temperature range (unless otherwise noted)

		MIN	MAX	UNIT
$t_{W(L)}$	Pulse duration, $\overline{\text{RESET}}$ low	6		ns
$t_{\text{REC(STA)}}$	Recovery time from $\overline{\text{RESET}}$ to start	0		ns

6.8 Switching Characteristics

over recommended operating free-air temperature range, $C_L \leq 100$ pF (unless otherwise noted) (see [Figure 3](#))

PARAMETER		FROM (INPUT)	TO (OUTPUT)	MIN	MAX	UNIT
t_{pd} ⁽¹⁾	Propagation delay time	$R_{\text{ON}} = 20 \Omega$, $C_L = 15$ pF	SDA or SCL		0.3	ns
		$R_{\text{ON}} = 20 \Omega$, $C_L = 50$ pF	SDA or SCL	SDn or SCn	1	
t_{rst} ⁽²⁾	$\overline{\text{RESET}}$ time (SDA clear)	$\overline{\text{RESET}}$	SDA		500	ns

- (1) The propagation delay is the calculated RC time constant of the typical ON-state resistance of the switch and the specified load capacitance, when driven by an ideal voltage source (zero output impedance).
- (2) t_{rst} is the propagation delay measured from the time the $\overline{\text{RESET}}$ pin is first asserted low to the time the SDA pin is asserted high, signaling a stop condition. It must be a minimum of $t_{W(L)}$.

6.9 Typical Characteristics

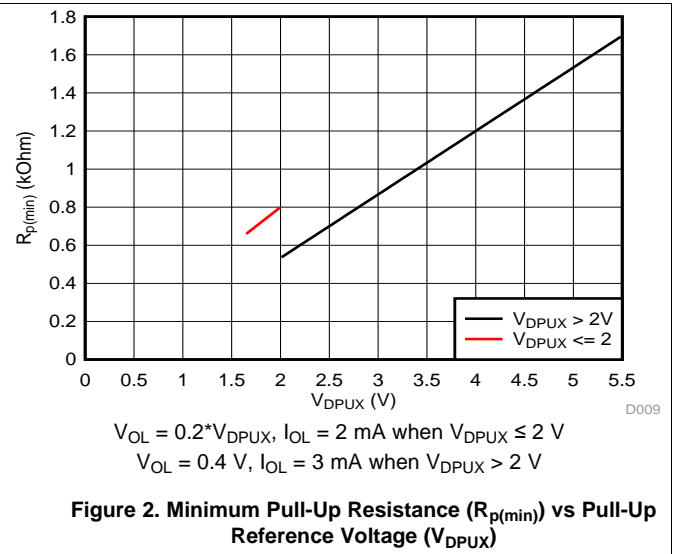
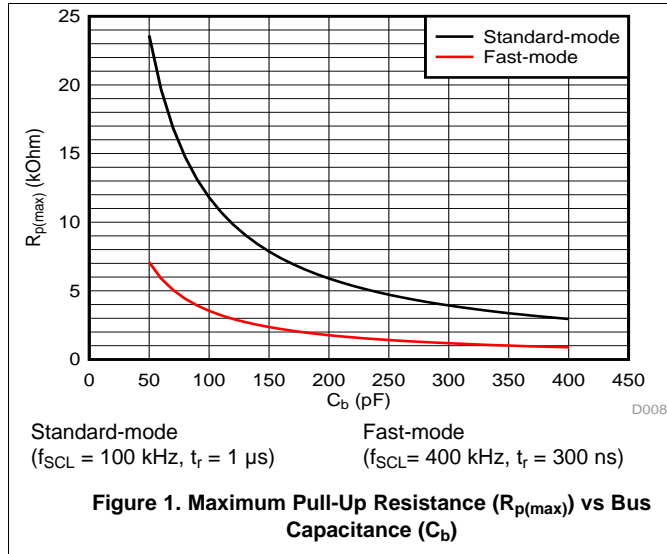

Parameter Measurement Information (continued)

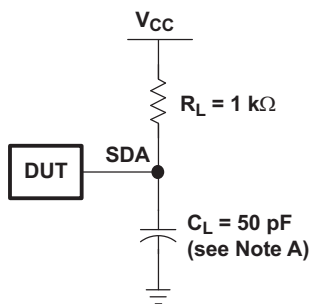

SDA LOAD CONFIGURATION

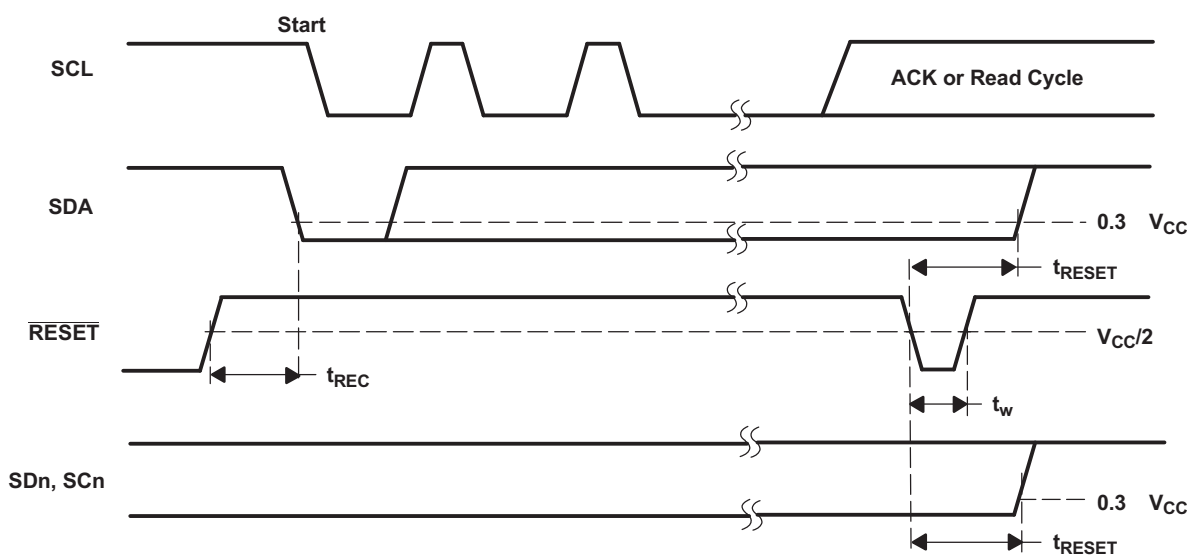

- A. C_L includes probe and jig capacitance.
- B. All inputs are supplied by generators having the following characteristics: $PRR \leq 10\text{ MHz}$, $Z_O = 50\ \Omega$, $t_r/t_f \leq 30\text{ ns}$.
- C. I/Os are configured as inputs.
- D. Not all parameters and waveforms are applicable to all devices.

Figure 4. Reset Load Circuit and Voltage Waveforms

8 Detailed Description

8.1 Overview

The PCA9548A is a 8-channel, bidirectional translating I²C switch. The master SCL/SDA signal pair is directed to eight channels of slave devices, SC0/SD0-SC3/SD3. Any individual downstream channel can be selected as well as any combination of the eight channels.

The device offers an active-low $\overline{\text{RESET}}$ input which resets the state machine and allows the PCA9548A to recover if one of the downstream I²C buses get stuck in a low state. The state machine of the device can also be reset by cycling the power supply, V_{CC} , also known as a power-on reset (POR). Both the $\overline{\text{RESET}}$ function and a POR cause all channels to be deselected.

The connections of the I²C data path are controlled by the same I²C master device that is switched to communicate with multiple I²C slaves. After the successful acknowledgment of the slave address (hardware selectable by A0 and A1 pins), a single 8-bit control register is written to or read from to determine the selected channels.

The PCA9548A may also be used for voltage translation, allowing the use of different bus voltages on each SCn/SDn pair such that 1.8-V, 2.5-V, or 3.3-V parts can communicate with 5-V parts. This is achieved by using external pull-up resistors to pull the bus up to the desired voltage for the master and each slave channel.

8.2 Functional Block Diagram

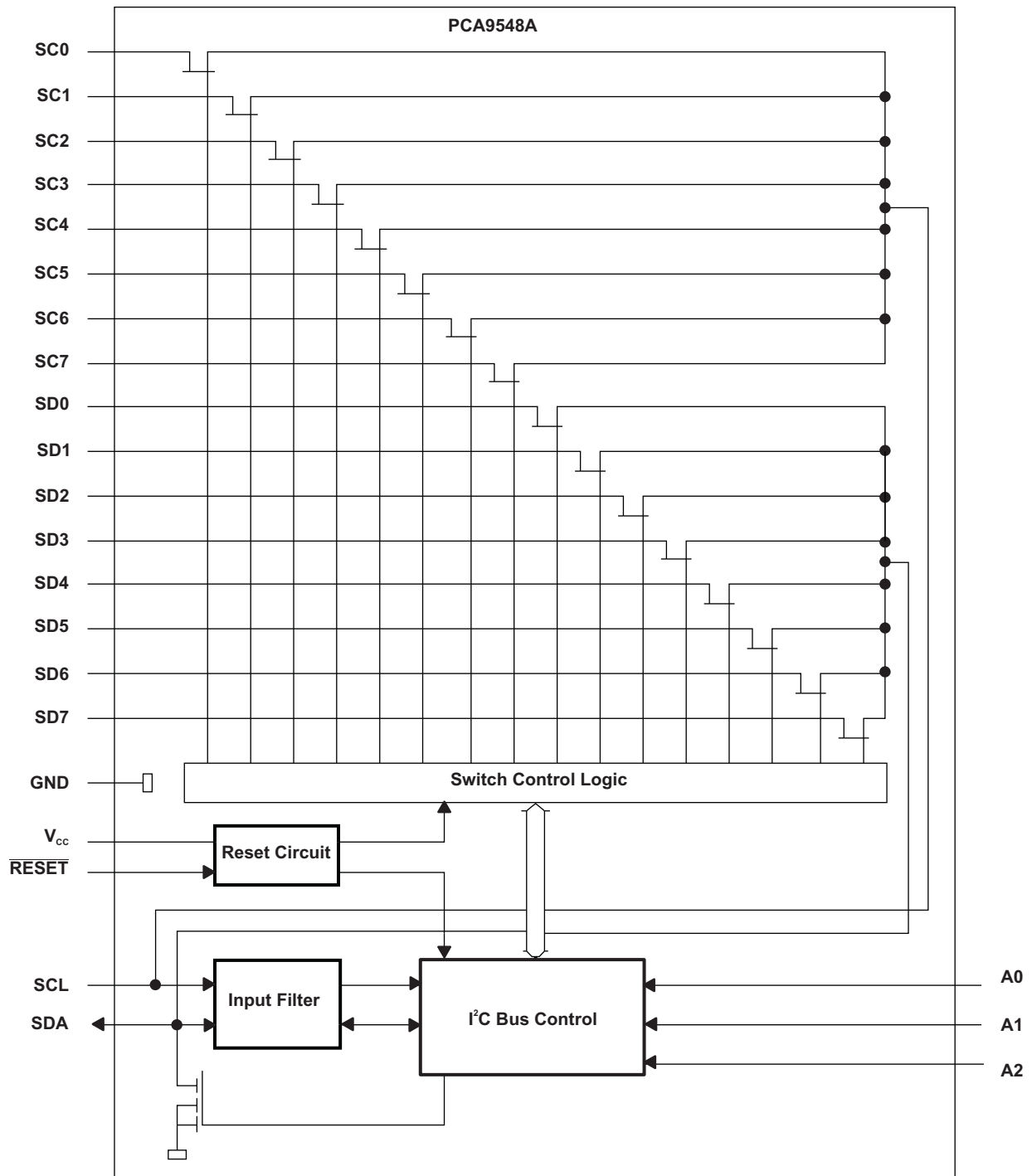

8.3 Feature Description

The PCA9548A is an 8-channel, bidirectional translating switch for I²C buses that supports Standard-Mode (100 kHz) and Fast-Mode (400 kHz) operation. The PCA9548A features I²C control using a single 8-bit control register in which each bit controls the enabling and disabling for one of the 8 switch channels of I²C data flow. Depending on the application, voltage translation of the I²C bus can also be achieved using the PCA9548A to allow 1.8-V, 2.5-V, or 3.3-V parts to communicate with 5-V parts. Additionally, in the event that communication on the I²C bus enters a fault state, the PCA9548A can be reset to resume normal operation using the $\overline{\text{RESET}}$ pin feature or by a power-on reset which results from cycling power to the device.

8.4 Device Functional Modes

8.4.1 $\overline{\text{RESET}}$ Input

The $\overline{\text{RESET}}$ input is an active-low signal that may be used to recover from a bus-fault condition. When this signal is asserted low for a minimum of t_{WL} , the PCA9548A resets its registers and I²C state machine and deselects all channels. The $\overline{\text{RESET}}$ input must be connected to V_{CC} through a pull-up resistor.

8.4.1.1 $\overline{\text{RESET}}$ Errata

If RESET voltage set higher than VCC, current flows from RESET pin to VCC pin.

8.4.1.1.1 System Impact

VCC is pulled above its regular voltage level.

8.4.1.1.2 System Workaround

Design such that $\overline{\text{RESET}}$ voltage is same or lower than VCC.

8.4.2 Power-On Reset

When power (from 0 V) is applied to V_{CC}, an internal power-on reset holds the PCA9548A in a reset condition until V_{CC} has reached V_{POR}. At that point, the reset condition is released and the PCA9548A registers and I²C state machine initialize to their default states. After that, V_{CC} must be lowered to below V_{POR} and then back up to the operating voltage for a power-reset cycle.

See the [Power-On Reset Errata](#) section.

8.5 Programming

8.5.1 I²C Interface

The bidirectional I²C bus consists of the serial clock (SCL) and serial data (SDA) lines. Both lines must be connected to a positive supply through a pull-up resistor when connected to the output stages of a device. Data transfer may be initiated only when the bus is not busy.

I²C communication with this device is initiated by a master sending a start condition, a high-to-low transition on the SDA input/output while the SCL input is high (see [Figure 5](#)). After the start condition, the device address byte is sent, most significant bit (MSB) first, including the data direction bit (R/W).

After receiving the valid address byte, this device responds with an acknowledge (ACK), a low on the SDA input/output during the high of the ACK-related clock pulse. The address inputs (A0–A2) of the slave device must not be changed between the start and the stop conditions.

On the I²C bus, only one data bit is transferred during each clock pulse. The data on the SDA line must remain stable during the high pulse of the clock period, as changes in the data line at this time are interpreted as control commands (start or stop) (see [Figure 6](#)).

A stop condition, a low-to-high transition on the SDA input/output while the SCL input is high, is sent by the master (see [Figure 5](#)).

Programming (continued)

Any number of data bytes can be transferred from the transmitter to receiver between the start and the stop conditions. Each byte of eight bits is followed by one ACK bit. The transmitter must release the SDA line before the receiver can send an ACK bit. The device that acknowledges must pull down the SDA line during the ACK-related clock pulse so that the SDA line is stable low during the high pulse of the ACK-related clock period (see Figure 7). When a slave receiver is addressed, it must generate an ACK after each byte is received. Similarly, the master must generate an ACK after each byte that it receives from the slave transmitter. Setup and hold times must be met to ensure proper operation.

A master receiver signals an end of data to the slave transmitter by not generating an acknowledge (NACK) after the last byte has been clocked out of the slave. This is done by the master receiver by holding the SDA line high. In this event, the transmitter must release the data line to enable the master to generate a stop condition.

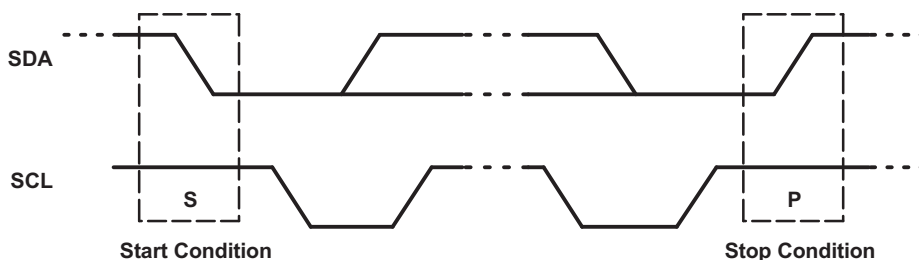

Figure 5. Definition of Start and Stop Conditions

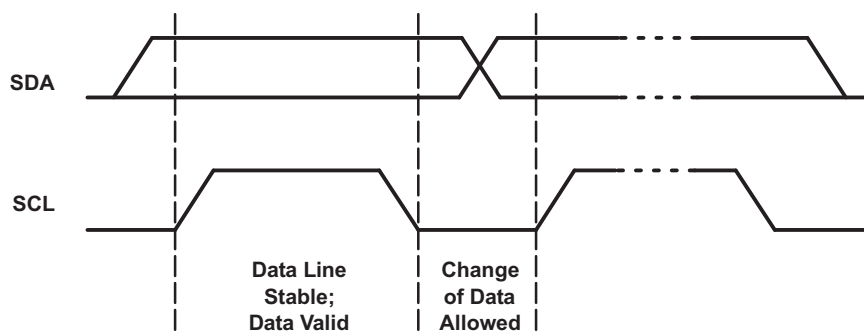

Figure 6. Bit Transfer

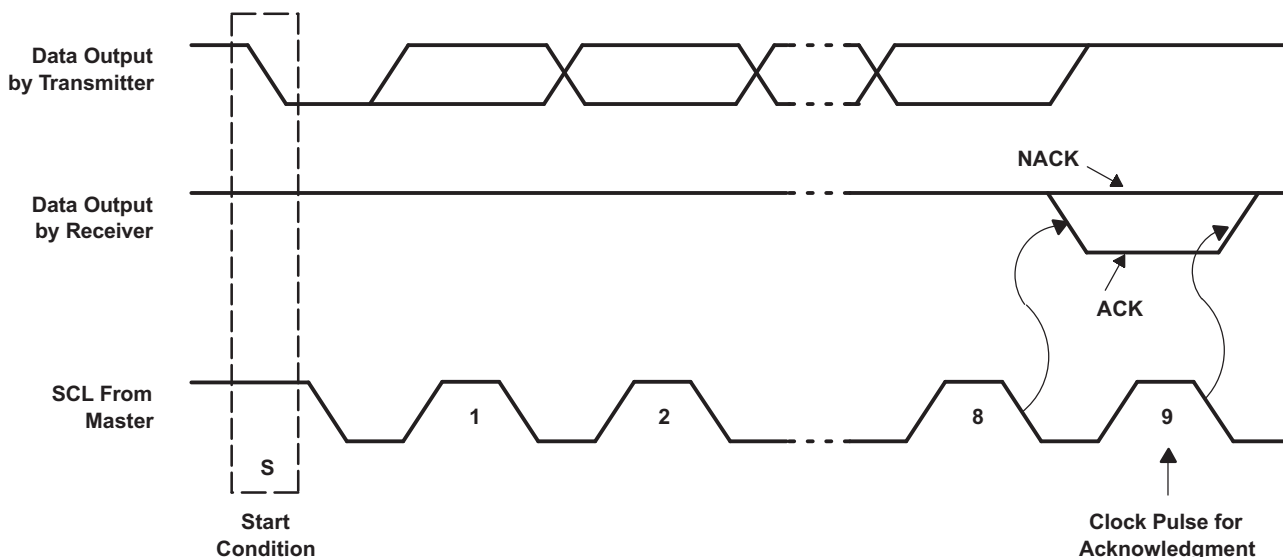

Figure 7. Acknowledgment on I²C Bus

8.6 Register Maps

8.6.1 Device Address

Figure 8 shows the address byte of the PCA9548A.

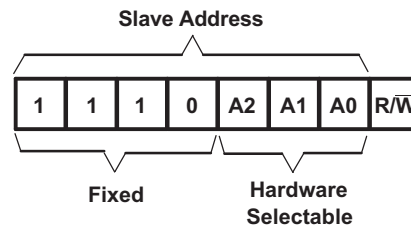

Figure 8. PCA9548A Address

The last bit of the slave address defines the operation (read or write) to be performed. When it is high (1), a read is selected, while a low (0) selects a write operation.

Table 1 shows the PCA9548A address reference.

Table 1. Address Reference

INPUTS			I ² C BUS SLAVE ADDRESS
A2	A1	A0	
L	L	L	112 (decimal), 70 (hexadecimal)
L	L	H	113 (decimal), 71 (hexadecimal)
L	H	L	114 (decimal), 72 (hexadecimal)
L	H	H	115 (decimal), 73 (hexadecimal)
H	L	L	116 (decimal), 74 (hexadecimal)
H	L	H	117 (decimal), 75 (hexadecimal)
H	H	L	118 (decimal), 76 (hexadecimal)
H	H	H	119 (decimal), 77 (hexadecimal)

8.6.2 Control Register

Following the successful acknowledgment of the address byte, the bus master sends a command byte that is stored in the control register in the PCA9548A (see Figure 9). This register can be written and read via the I²C bus. Each bit in the command byte corresponds to a SCn/SDn channel and a high (or 1) selects this channel. Multiple SCn/SDn channels may be selected at the same time. When a channel is selected, the channel becomes active after a stop condition has been placed on the I²C bus. This ensures that all SCn/SDn lines are in a high state when the channel is made active, so that no false conditions are generated at the time of connection. A stop condition always must occur immediately after the acknowledge cycle. If multiple bytes are received by the PCA9548A, it saves the last byte received.

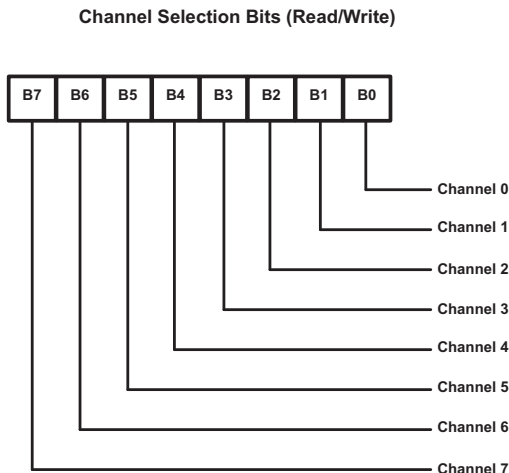

Figure 9. Control Register

Table 2 shows the PCA9548A Command byte definition.

Table 2. Command Byte Definition

CONTROL REGISTER BITS								COMMAND
B7	B6	B5	B4	B3	B2	B1	B0	
X	X	X	X	X	X	X	0	Channel 0 disabled
							1	Channel 0 enabled
X	X	X	X	X	X	0	X	Channel 1 disabled
							1	Channel 1 enabled
X	X	X	X	X	0	X	X	Channel 2 disabled
							1	Channel 2 enabled
X	X	X	X	0	X	X	X	Channel 3 disabled
							1	Channel 3 enabled
X	X	X	0	X	X	X	X	Channel 4 disabled
			1					Channel 4 enabled
X	X	0	X	X	X	X	X	Channel 5 disabled
		1						Channel 5 enabled
X	0	X	X	X	X	X	X	Channel 6 disabled
	1							Channel 6 enabled
0	X	X	X	X	X	X	X	Channel 7 disabled
1								Channel 7 enabled
0	0	0	0	0	0	0	0	No channel selected, power-up/reset default state

8.6.3 Bus Transactions

Data is exchanged between the master and PCA9548A through write and read commands.

8.6.3.1 Writes

Data is transmitted to the PCA9548A by sending the device address and setting the least-significant bit (LSB) to a logic 0 (see [Figure 8](#) for device address). The command byte is sent after the address and determines which SCn/SDn channel receives the data that follows the command byte (see [Figure 10](#)). There is no limitation on the number of data bytes sent in one write transmission.

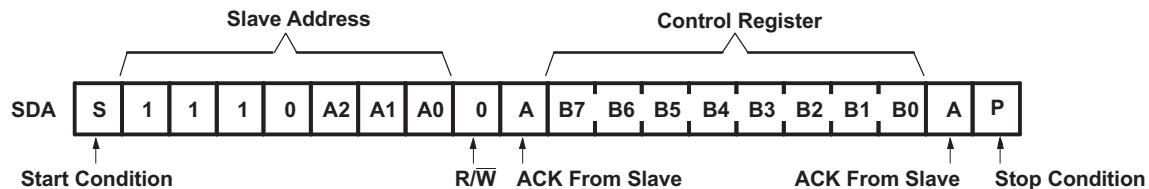

Figure 10. Write to Control Register

8.6.3.2 Reads

The bus master first must send the PCA9548A address with the LSB set to a logic 1 (see [Figure 8](#) for device address). The command byte is sent after the address and determines which SCn/SDn channel is accessed. After a restart, the device address is sent again, but this time, the LSB is set to a logic 1. Data from the SCn/SDn channel defined by the command byte then is sent by the PCA9548A (see [Figure 11](#)). After a restart, the value of the SCn/SDn channel defined by the command byte matches the SCn/SDn channel being accessed when the restart occurred. Data is clocked into the SCn/SDn channel on the rising edge of the ACK clock pulse. There is no limitation on the number of data bytes received in one read transmission, but when the final byte is received, the bus master must not acknowledge the data.

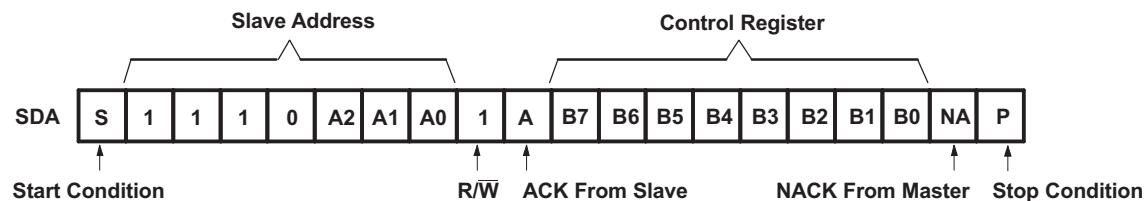

Figure 11. Read From Control Register

9 Application and Implementation

NOTE

Information in the following applications sections is not part of the TI component specification, and TI does not warrant its accuracy or completeness. TI's customers are responsible for determining suitability of components for their purposes. Customers should validate and test their design implementation to confirm system functionality.

9.1 Application Information

Applications of the PCA9548A contain an I²C (or SMBus) master device and up to eight I²C slave devices. The downstream channels are ideally used to resolve I²C slave address conflicts. For example, if eight identical digital temperature sensors are needed in the application, one sensor can be connected at each channel: 0, 1, 2, and 3. When the temperature at a specific location needs to be read, the appropriate channel can be enabled and all other channels switched off, the data can be retrieved, and the I²C master can move on and read the next channel.

In an application where the I²C bus contains many additional slave devices that do not result in I²C slave address conflicts, these slave devices can be connected to any desired channel to distribute the total bus capacitance across multiple channels. If multiple switches are enabled simultaneously, additional design requirements must be considered (See the [Design Requirements](#) and [Detailed Design Procedure](#) sections).

9.2 Typical Application

A typical application of the PCA9548A contains 1 or many separate data pull-up voltages, V_{CC} , one for the master device and one for each of the selectable slave channels, 0 through 7. In the event where the master device and all slave devices operate at the same voltage, then the VCC pin can be connected to this supply voltage. In an application where voltage translation is necessary, additional design requirements must be considered (See the [Design Requirements](#) section).

[Figure 12](#) shows an application in which the PCA9548A can be used.

Typical Application (continued)

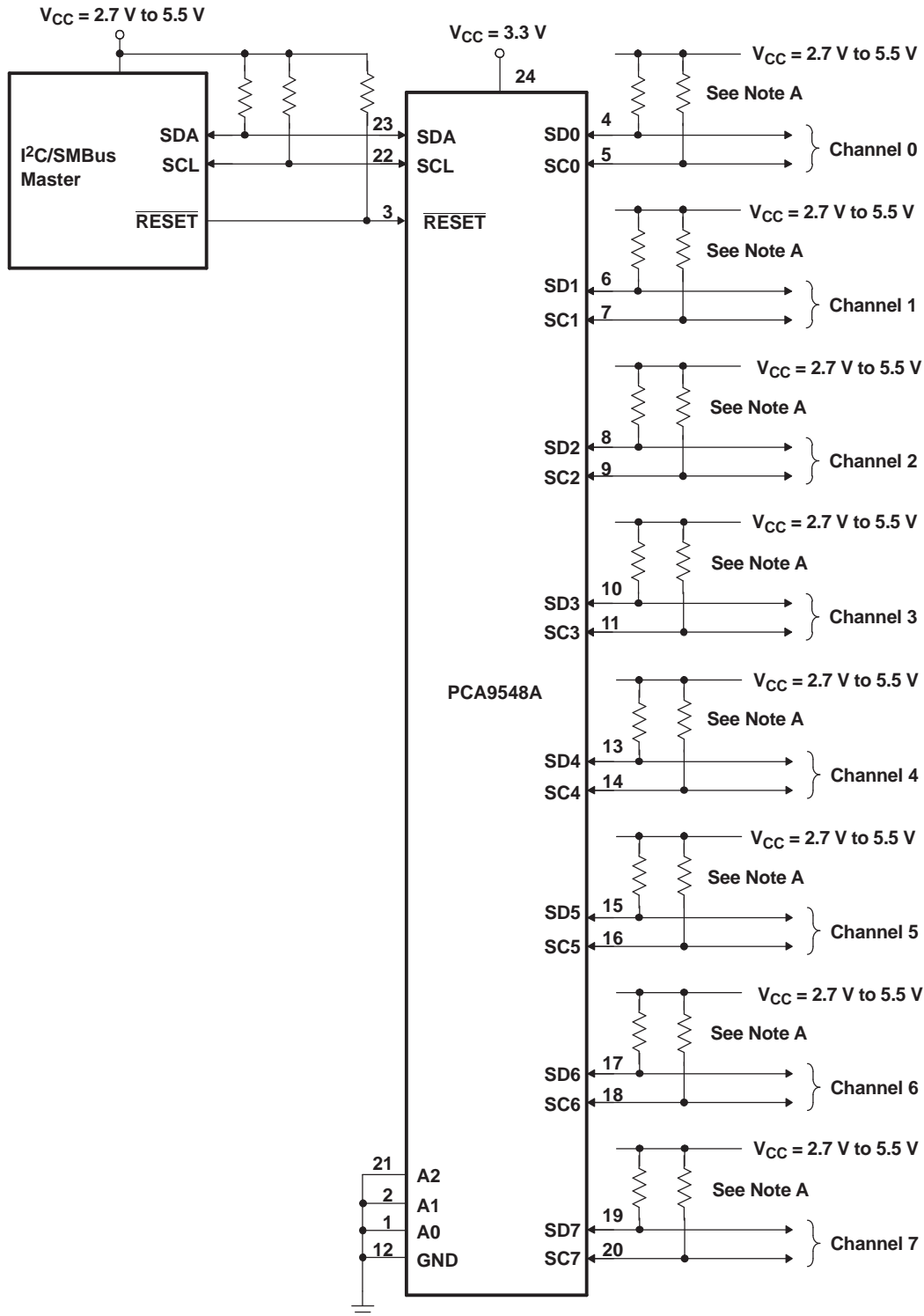

A. Pin numbers shown are for the PW and RTW packages.

Figure 12. PCA9548A Typical Application Schematic

Typical Application (continued)

9.2.1 Design Requirements

The A0, A1, and A2 pins are hardware selectable to control the slave address of the PCA9548A. These pins may be tied directly to GND or V_{CC} in the application.

If multiple slave channels are activated simultaneously in the application, then the total I_{OL} from SCL/SDA to GND on the master side is the sum of the currents through all pull-up resistors, R_p .

The pass-gate transistors of the PCA9548A are constructed such that the V_{CC} voltage can be used to limit the maximum voltage that is passed from one I²C bus to another.

Figure 13 shows the voltage characteristics of the pass-gate transistors (note that the graph was generated using data specified in the [Electrical Characteristics](#) section of this data sheet). In order for the PCA9548A to act as a voltage translator, the V_{pass} voltage must be equal to or lower than the lowest bus voltage. For example, if the main bus is running at 5 V and the downstream buses are 3.3 V and 2.7 V, V_{pass} must be equal to or below 2.7 V to effectively clamp the downstream bus voltages. As shown in Figure 13, $V_{pass(max)}$ is 2.7 V when the PCA9548A supply voltage is 4 V or lower, so the PCA9548A supply voltage could be set to 3.3 V. Pull-up resistors then can be used to bring the bus voltages to their appropriate levels (see Figure 12).

9.2.2 Detailed Design Procedure

Once all the slaves are assigned to the appropriate slave channels and bus voltages are identified, the pull-up resistors, R_p , for each of the buses need to be selected appropriately. The minimum pull-up resistance is a function of the reference voltage of the specific I²C channel (V_{DPUX}), $V_{OL(max)}$, and I_{OL} as shown in Equation 1.

$$R_{p(min)} = \frac{V_{DPUX} - V_{OL(max)}}{I_{OL}} \quad (1)$$

The maximum pull-up resistance is a function of the maximum rise time, t_r (300 ns for fast-mode operation, $f_{SCL} = 400$ kHz) and bus capacitance, C_b is given by Equation 2.

$$R_{p(max)} = \frac{t_r}{0.8473 \times C_b} \quad (2)$$

The maximum bus capacitance for an I²C bus must not exceed 400 pF for fast-mode operation. The bus capacitance can be approximated by adding the capacitance of the PCA9548A, $C_{iO(OFF)}$, the capacitance of wires, connections, traces, and the capacitance of each individual slave on a given channel. If multiple channels are activated simultaneously, each of the slaves on all channels contribute to total bus capacitance.

Typical Application (continued)

9.2.3 Application Curves

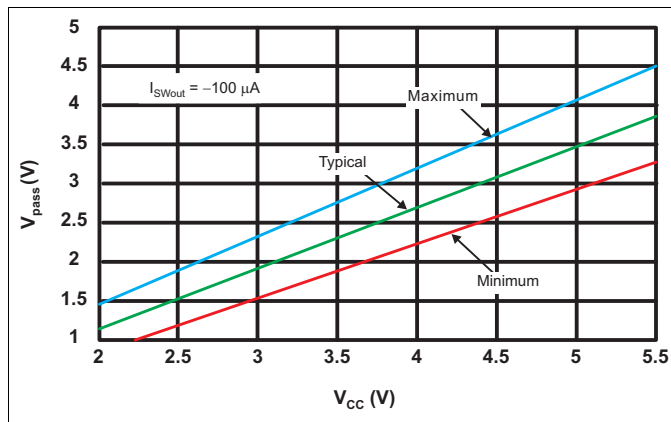

Figure 13. Pass-Gate Voltage (V_{pass}) vs Supply Voltage (V_{CC}) at Three Temperature Points

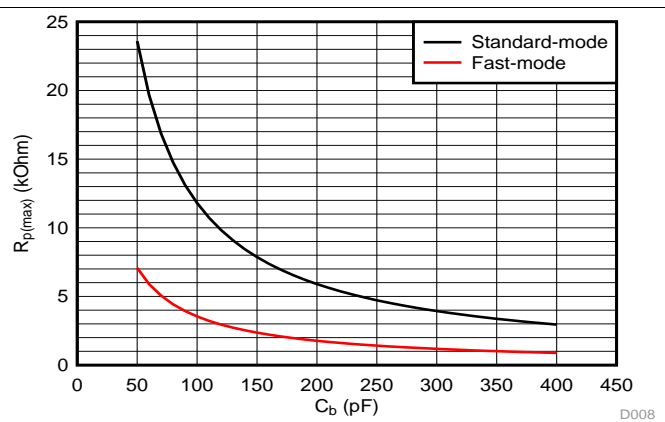

Figure 14. Maximum Pull-Up Resistance ($R_{p(max)}$) vs Bus Capacitance (C_b)

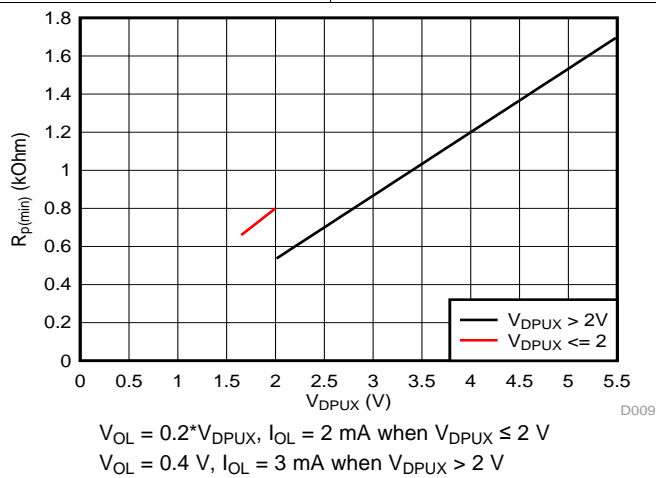

Figure 15. Minimum Pull-Up Resistance ($R_{p(min)}$) vs Pull-Up Reference Voltage (V_{DPUX})

10 Power Supply Recommendations

The operating power-supply voltage range of the PCA9548A is 2.3 V to 5.5 V applied at the VCC pin. When the PCA9548A is powered on for the first time or anytime the device needs to be reset by cycling the power supply, the power-on reset requirements must be followed to ensure the I²C bus logic is initialized properly.

10.1 Power-On Reset Errata

A power-on reset condition can be missed if the VCC ramps are outside specification listed in [Figure 16](#).

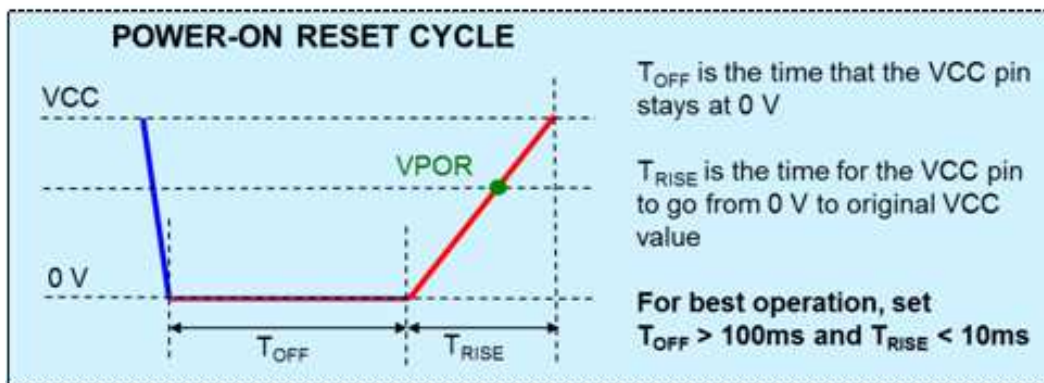

Figure 16. Power-On Reset Cycle

10.1.1 System Impact

If ramp conditions are outside timing allowances above, POR condition can be missed, causing the device to lock up.

11 Layout

11.1 Layout Guidelines

For PCB layout of the PCA9548A, common PCB layout practices must be followed but additional concerns related to high-speed data transfer such as matched impedances and differential pairs are not a concern for I²C signal speeds. It is common to have a dedicated ground plane on an inner layer of the board and pins that are connected to ground must have a low-impedance path to the ground plane in the form of wide polygon pours and multiple vias. By-pass and de-coupling capacitors are commonly used to control the voltage on the VCC pin, using a larger capacitor to provide additional power in the event of a short power supply glitch and a smaller capacitor to filter out high-frequency ripple.

In an application where voltage translation is not required, all V_{DPUX} voltages and V_{CC} could be at the same potential and a single copper plane could connect all of pull-up resistors to the appropriate reference voltage. In an application where voltage translation is required, V_{DPU0} and $V_{DPU0} - V_{DPU7}$ may all be on the same layer of the board with split planes to isolate different voltage potentials.

To reduce the total I²C bus capacitance added by PCB parasitics, data lines (SCn and SDn) must be as short as possible and the widths of the traces must also be minimized (For example, 5-10 mils depending on copper weight).

11.2 Layout Example

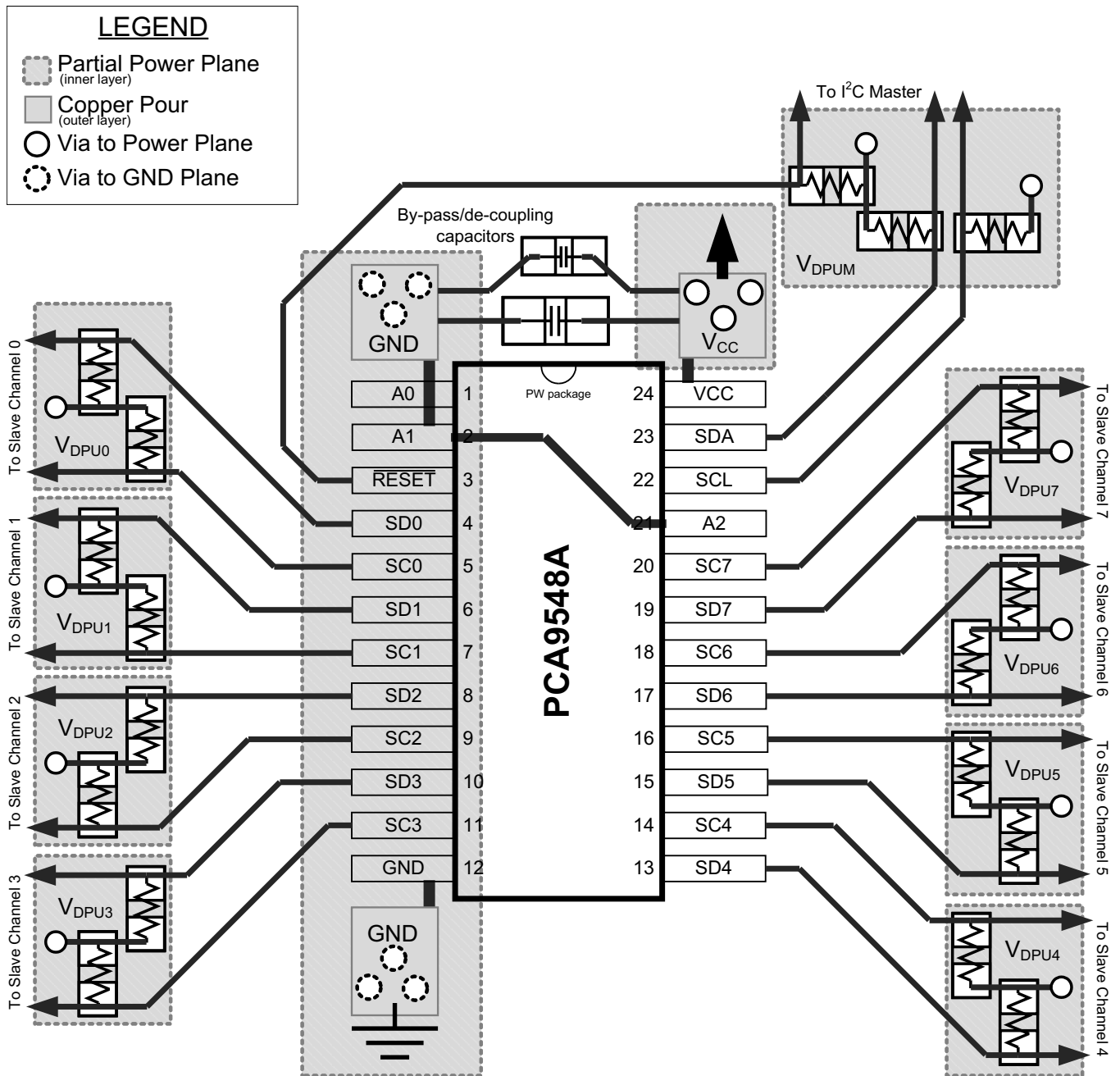

Figure 17. Layout Example

12 Device and Documentation Support

12.1 Related Documentation

For related documentation see the following:

- [I2C Bus Pull-Up Resistor Calculation](#)
- [Maximum Clock Frequency of I2C Bus Using Repeaters](#)
- [Introduction to Logic](#)
- [Understanding the I2C Bus](#)
- [Choosing the Correct I2C Device for New Designs](#)

12.2 Receiving Notification of Documentation Updates

To receive notification of documentation updates—including silicon errata—go to the product folder for your device on [ti.com](#). In the upper right-hand corner, click the *Alert me* button. This registers you to receive a weekly digest of product information that has changed (if any). For change details, check the revision history of any revised document.

12.3 Community Resources

The following links connect to TI community resources. Linked contents are provided "AS IS" by the respective contributors. They do not constitute TI specifications and do not necessarily reflect TI's views; see TI's [Terms of Use](#).

TI E2E™ Online Community *TI's Engineer-to-Engineer (E2E) Community*. Created to foster collaboration among engineers. At [e2e.ti.com](#), you can ask questions, share knowledge, explore ideas and help solve problems with fellow engineers.

Design Support *TI's Design Support* Quickly find helpful E2E forums along with design support tools and contact information for technical support.

12.4 Trademarks

E2E is a trademark of Texas Instruments.
All other trademarks are the property of their respective owners.

12.5 Electrostatic Discharge Caution



This integrated circuit can be damaged by ESD. Texas Instruments recommends that all integrated circuits be handled with appropriate precautions. Failure to observe proper handling and installation procedures can cause damage.

ESD damage can range from subtle performance degradation to complete device failure. Precision integrated circuits may be more susceptible to damage because very small parametric changes could cause the device not to meet its published specifications.

12.6 Glossary

[SLYZ022](#) — *TI Glossary*.

This glossary lists and explains terms, acronyms, and definitions.

13 Mechanical, Packaging, and Orderable Information

The following pages include mechanical, packaging, and orderable information. This information is the most current data available for the designated devices. This data is subject to change without notice and revision of this document. For browser-based versions of this data sheet, refer to the left-hand navigation.

PACKAGING INFORMATION

Orderable Device	Status (1)	Package Type	Package Drawing	Pins	Package Qty	Eco Plan (2)	Lead/Ball Finish (6)	MSL Peak Temp (3)	Op Temp (°C)	Device Marking (4/5)	Samples
PCA9548ADB	ACTIVE	SSOP	DB	24	60	Green (RoHS & no Sb/Br)	CU NIPDAU	Level-1-260C-UNLIM	-40 to 85	PD548A	Samples
PCA9548ADBG4	ACTIVE	SSOP	DB	24	60	Green (RoHS & no Sb/Br)	CU NIPDAU	Level-1-260C-UNLIM	-40 to 85	PD548A	Samples
PCA9548ADBR	ACTIVE	SSOP	DB	24	2000	Green (RoHS & no Sb/Br)	CU NIPDAU	Level-1-260C-UNLIM	-40 to 85	PD548A	Samples
PCA9548ADGV	NRND	TVSOP	DGV	24		TBD	Call TI	Call TI	-40 to 85		
PCA9548ADGVR	ACTIVE	TVSOP	DGV	24	2000	Green (RoHS & no Sb/Br)	CU NIPDAU	Level-1-260C-UNLIM	-40 to 85	PD548A	Samples
PCA9548ADW	ACTIVE	SOIC	DW	24	25	Green (RoHS & no Sb/Br)	CU NIPDAU	Level-1-260C-UNLIM	-40 to 85	PCA9548A	Samples
PCA9548ADWG4	ACTIVE	SOIC	DW	24	25	Green (RoHS & no Sb/Br)	CU NIPDAU	Level-1-260C-UNLIM	-40 to 85	PCA9548A	Samples
PCA9548ADWR	ACTIVE	SOIC	DW	24	2000	Green (RoHS & no Sb/Br)	CU NIPDAU	Level-1-260C-UNLIM	-40 to 85	PCA9548A	Samples
PCA9548APW	NRND	TSSOP	PW	24	60	Green (RoHS & no Sb/Br)	CU NIPDAU	Level-1-260C-UNLIM	-40 to 85	PD548A	
PCA9548APWR	NRND	TSSOP	PW	24	2000	Green (RoHS & no Sb/Br)	CU NIPDAU	Level-1-260C-UNLIM	-40 to 85	PD548A	
PCA9548APWRG4	NRND	TSSOP	PW	24	2000	Green (RoHS & no Sb/Br)	CU NIPDAU	Level-1-260C-UNLIM	-40 to 85	PD548A	
PCA9548ARGER	NRND	VQFN	RGE	24	3000	Green (RoHS & no Sb/Br)	CU NIPDAU	Level-2-260C-1 YEAR	-40 to 85	PD548A	

(1) The marketing status values are defined as follows:

ACTIVE: Product device recommended for new designs.

LIFEBUY: TI has announced that the device will be discontinued, and a lifetime-buy period is in effect.

NRND: Not recommended for new designs. Device is in production to support existing customers, but TI does not recommend using this part in a new design.

PREVIEW: Device has been announced but is not in production. Samples may or may not be available.

OBSELETE: TI has discontinued the production of the device.

(2) Eco Plan - The planned eco-friendly classification: Pb-Free (RoHS), Pb-Free (RoHS Exempt), or Green (RoHS & no Sb/Br) - please check <http://www.ti.com/productcontent> for the latest availability information and additional product content details.

TBD: The Pb-Free/Green conversion plan has not been defined.

Pb-Free (RoHS): TI's terms "Lead-Free" or "Pb-Free" mean semiconductor products that are compatible with the current RoHS requirements for all 6 substances, including the requirement that lead not exceed 0.1% by weight in homogeneous materials. Where designed to be soldered at high temperatures, TI Pb-Free products are suitable for use in specified lead-free processes.

Pb-Free (RoHS Exempt): This component has a RoHS exemption for either 1) lead-based flip-chip solder bumps used between the die and package, or 2) lead-based die adhesive used between the die and leadframe. The component is otherwise considered Pb-Free (RoHS compatible) as defined above.

Green (RoHS & no Sb/Br): TI defines "Green" to mean Pb-Free (RoHS compatible), and free of Bromine (Br) and Antimony (Sb) based flame retardants (Br or Sb do not exceed 0.1% by weight in homogeneous material)

⁽³⁾ MSL, Peak Temp. - The Moisture Sensitivity Level rating according to the JEDEC industry standard classifications, and peak solder temperature.

⁽⁴⁾ There may be additional marking, which relates to the logo, the lot trace code information, or the environmental category on the device.

⁽⁵⁾ Multiple Device Markings will be inside parentheses. Only one Device Marking contained in parentheses and separated by a "~" will appear on a device. If a line is indented then it is a continuation of the previous line and the two combined represent the entire Device Marking for that device.

⁽⁶⁾ Lead/Ball Finish - Orderable Devices may have multiple material finish options. Finish options are separated by a vertical ruled line. Lead/Ball Finish values may wrap to two lines if the finish value exceeds the maximum column width.

Important Information and Disclaimer: The information provided on this page represents TI's knowledge and belief as of the date that it is provided. TI bases its knowledge and belief on information provided by third parties, and makes no representation or warranty as to the accuracy of such information. Efforts are underway to better integrate information from third parties. TI has taken and continues to take reasonable steps to provide representative and accurate information but may not have conducted destructive testing or chemical analysis on incoming materials and chemicals. TI and TI suppliers consider certain information to be proprietary, and thus CAS numbers and other limited information may not be available for release.

In no event shall TI's liability arising out of such information exceed the total purchase price of the TI part(s) at issue in this document sold by TI to Customer on an annual basis.

TAPE AND REEL INFORMATION

QUADRANT ASSIGNMENTS FOR PIN 1 ORIENTATION IN TAPE

*All dimensions are nominal

Device	Package Type	Package Drawing	Pins	SPQ	Reel Diameter (mm)	Reel Width W1 (mm)	A0 (mm)	B0 (mm)	K0 (mm)	P1 (mm)	W (mm)	Pin1 Quadrant
PCA9548ADBR	SSOP	DB	24	2000	330.0	16.4	8.2	8.8	2.5	12.0	16.0	Q1
PCA9548ADGVR	TVSOP	DGV	24	2000	330.0	12.4	6.9	5.6	1.6	8.0	12.0	Q1
PCA9548ADWR	SOIC	DW	24	2000	330.0	24.4	10.75	15.7	2.7	12.0	24.0	Q1
PCA9548APWR	TSSOP	PW	24	2000	330.0	16.4	6.95	8.3	1.6	8.0	16.0	Q1
PCA9548ARGER	VQFN	RGE	24	3000	330.0	12.4	4.25	4.25	1.15	8.0	12.0	Q2

TAPE AND REEL BOX DIMENSIONS

*All dimensions are nominal

Device	Package Type	Package Drawing	Pins	SPQ	Length (mm)	Width (mm)	Height (mm)
PCA9548ADBR	SSOP	DB	24	2000	367.0	367.0	38.0
PCA9548ADGVR	TVSOP	DGV	24	2000	367.0	367.0	35.0
PCA9548ADWR	SOIC	DW	24	2000	350.0	350.0	43.0
PCA9548APWR	TSSOP	PW	24	2000	367.0	367.0	38.0
PCA9548ARGER	VQFN	RGE	24	3000	367.0	367.0	35.0

DW (R-PDSO-G24)

PLASTIC SMALL OUTLINE

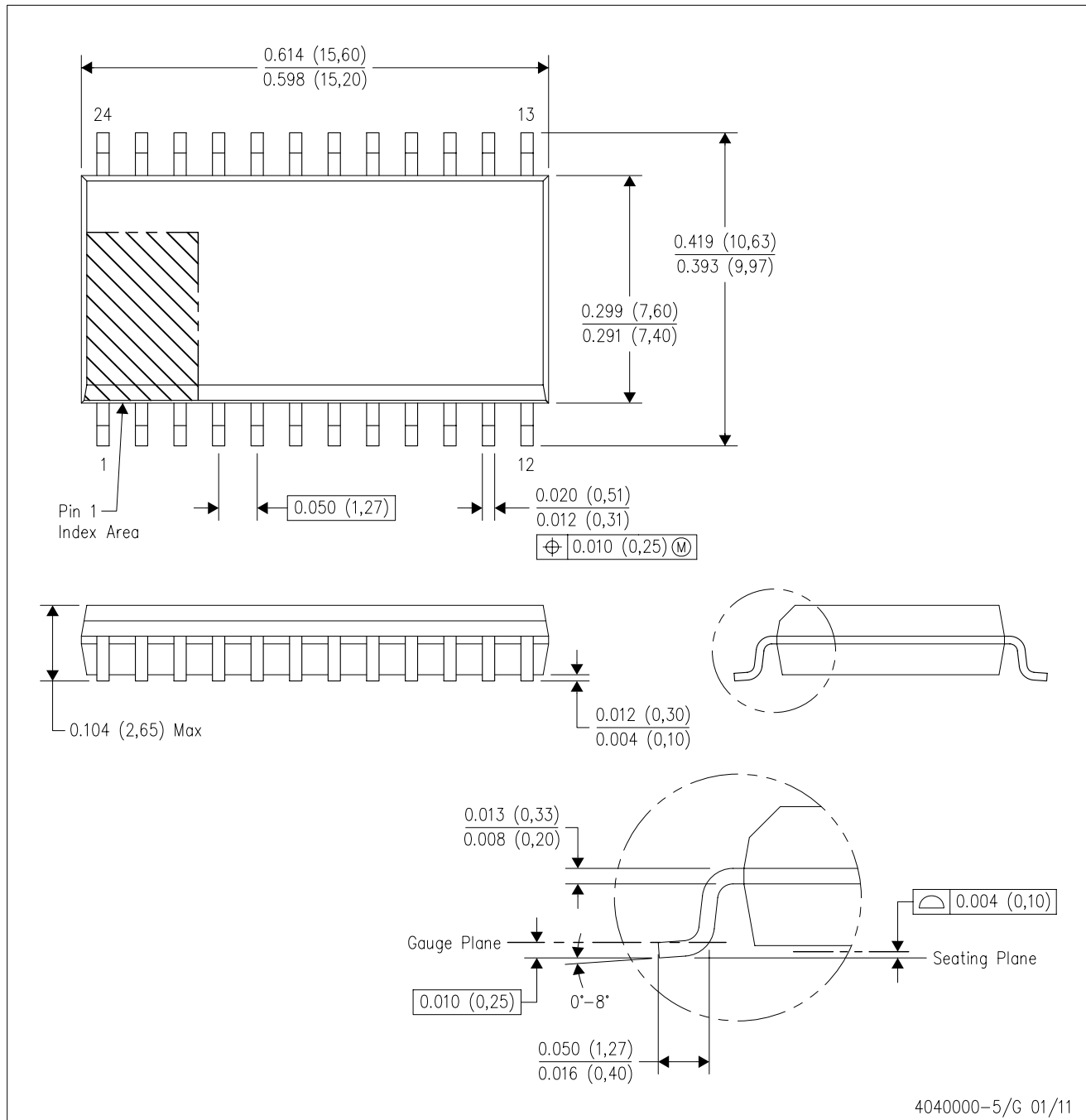

- NOTES:
- A. All linear dimensions are in inches (millimeters). Dimensioning and tolerancing per ASME Y14.5M-1994.
 - B. This drawing is subject to change without notice.
 - C. Body dimensions do not include mold flash or protrusion not to exceed 0.006 (0,15).
 - D. Falls within JEDEC MS-013 variation AD.

DB (R-PDSO-G**)

PLASTIC SMALL-OUTLINE

28 PINS SHOWN



- NOTES: A. All linear dimensions are in millimeters.
 B. This drawing is subject to change without notice.
 C. Body dimensions do not include mold flash or protrusion not to exceed 0,15.
 D. Falls within JEDEC MO-150

RGE 24

GENERIC PACKAGE VIEW

VQFN - 1 mm max height

PLASTIC QUAD FLATPACK - NO LEAD



Images above are just a representation of the package family, actual package may vary.
Refer to the product data sheet for package details.

4204104/H

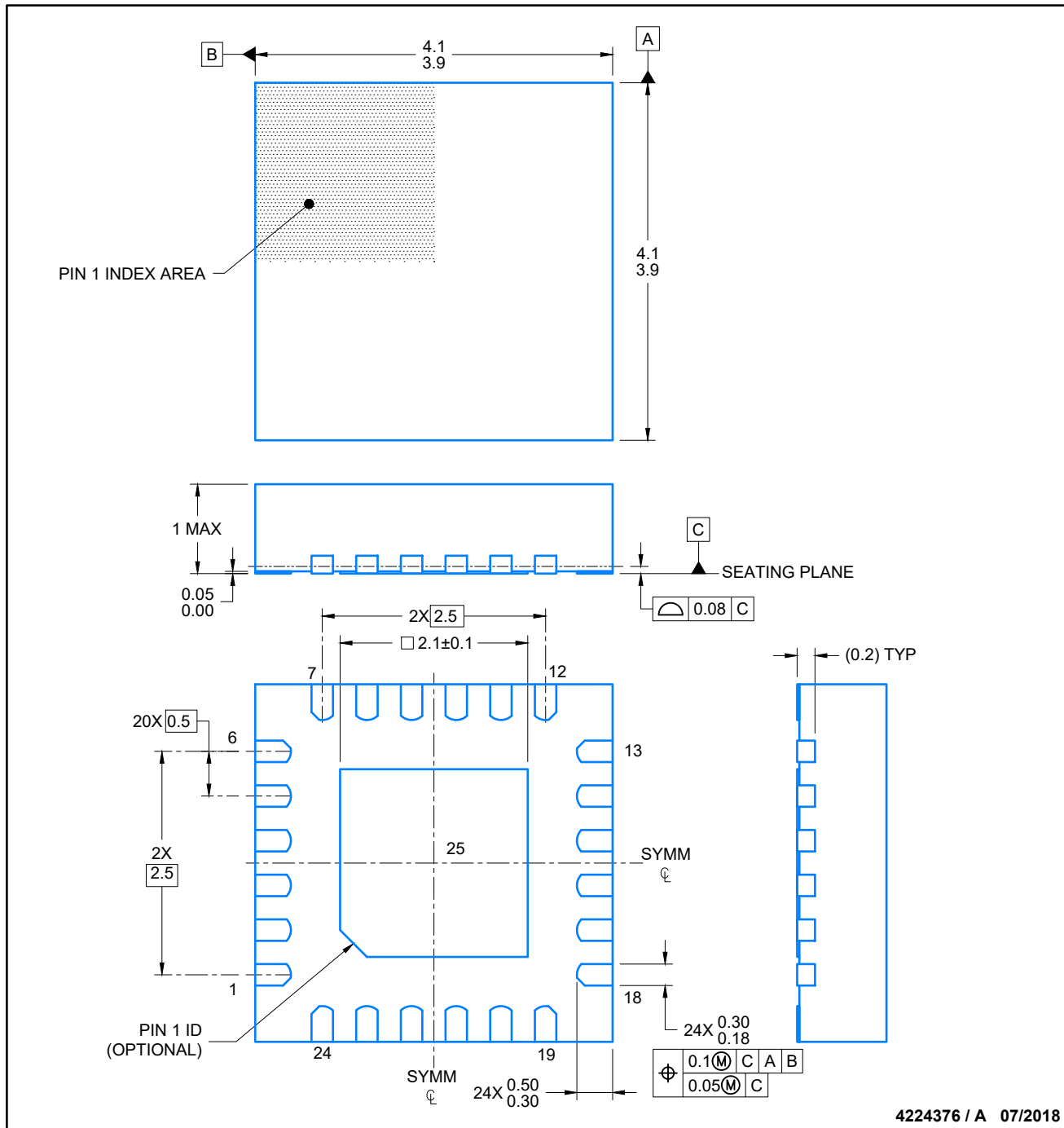

4224376 / A 07/2018

NOTES:

1. All linear dimensions are in millimeters. Any dimensions in parenthesis are for reference only. Dimensioning and tolerancing per ASME Y14.5M.
2. This drawing is subject to change without notice.
3. The package thermal pad must be soldered to the printed circuit board for thermal and mechanical performance.

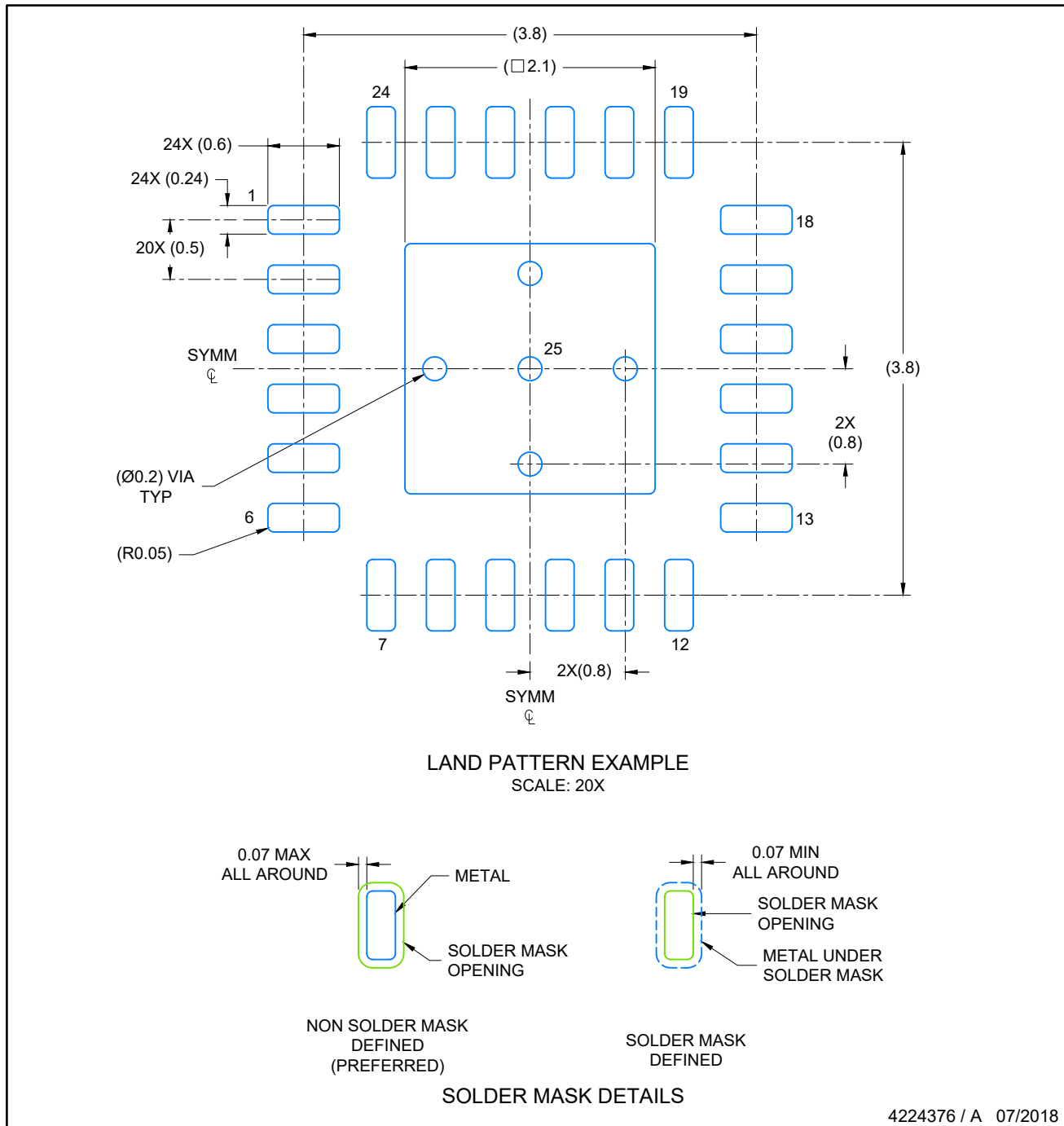

NOTES: (continued)

4. This package is designed to be soldered to a thermal pad on the board. For more information, see Texas Instruments literature number SLUA271 (www.ti.com/lit/slua271).
5. Solder mask tolerances between and around signal pads can vary based on board fabrication site.

EXAMPLE STENCIL DESIGN

VQFN - 1 mm max height

RGE0024C

PLASTIC QUAD FLATPACK- NO LEAD

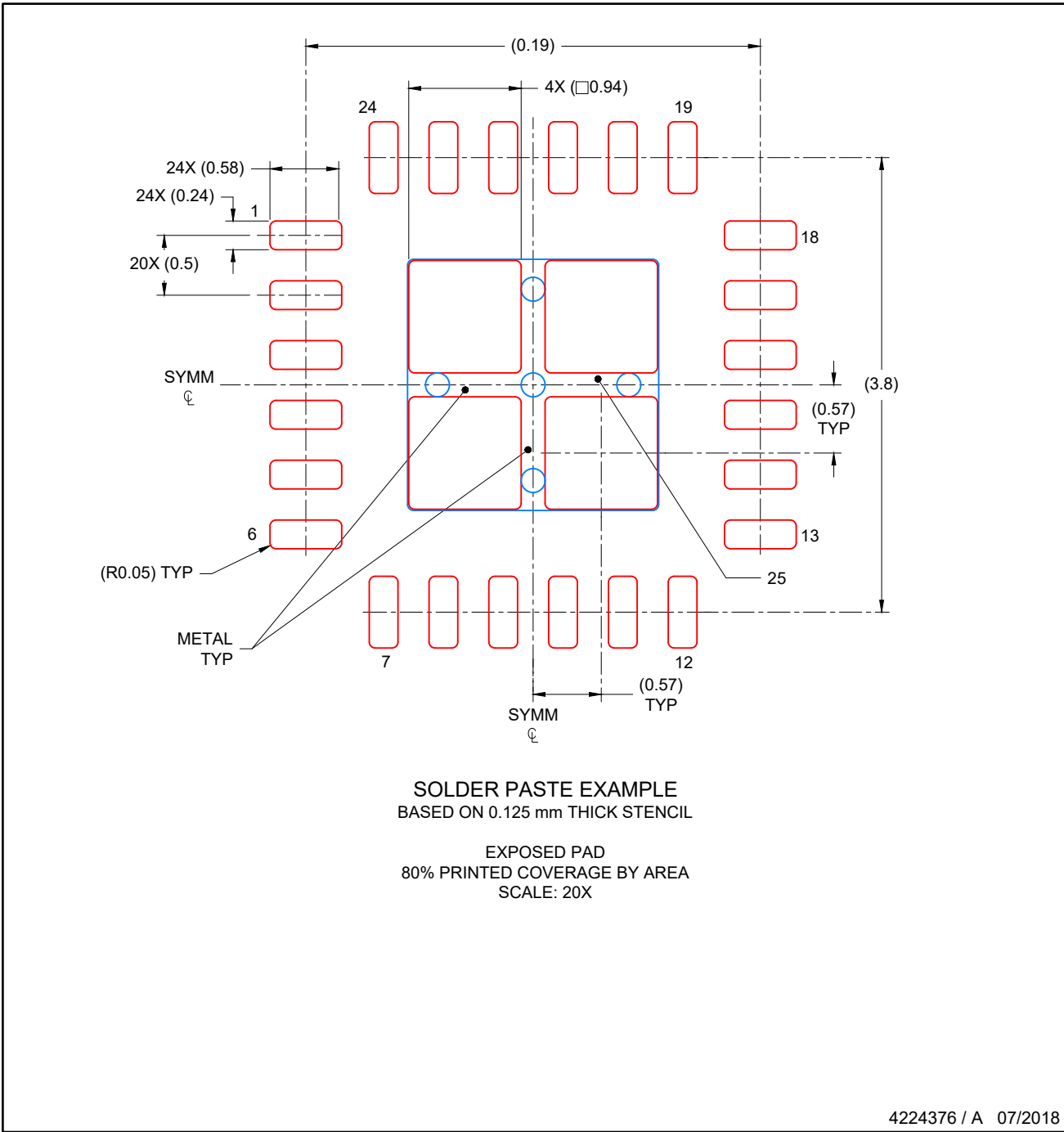

4224376 / A 07/2018

NOTES: (continued)

- 6. Laser cutting apertures with trapezoidal walls and rounded corners may offer better paste release. IPC-7525 may have alternate design recommendations..

EXAMPLE BOARD LAYOUT

PW0024A

TSSOP - 1.2 mm max height

SMALL OUTLINE PACKAGE

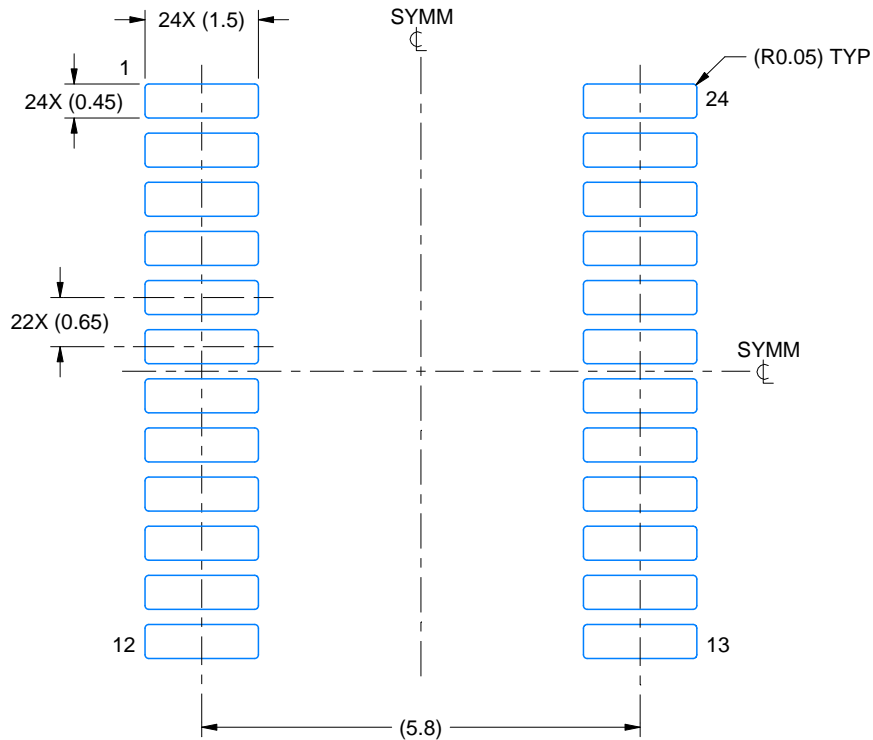

LAND PATTERN EXAMPLE
EXPOSED METAL SHOWN
SCALE: 10X

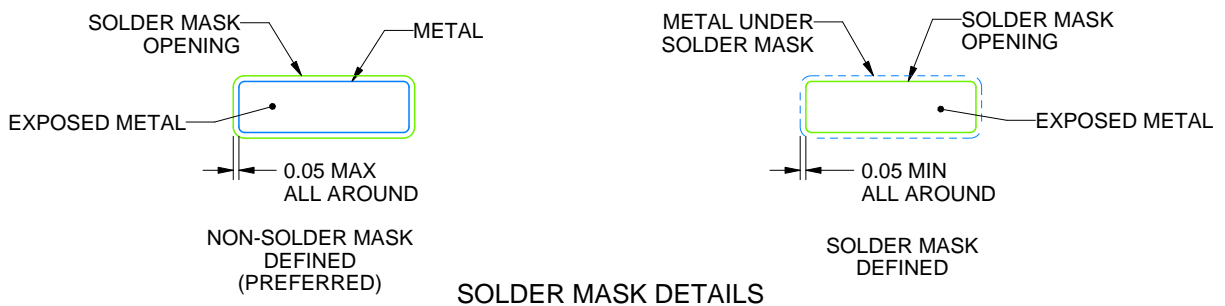

SOLDER MASK DETAILS

4220208/A 02/2017

NOTES: (continued)

6. Publication IPC-7351 may have alternate designs.
7. Solder mask tolerances between and around signal pads can vary based on board fabrication site.

EXAMPLE STENCIL DESIGN

PW0024A

TSSOP - 1.2 mm max height

SMALL OUTLINE PACKAGE

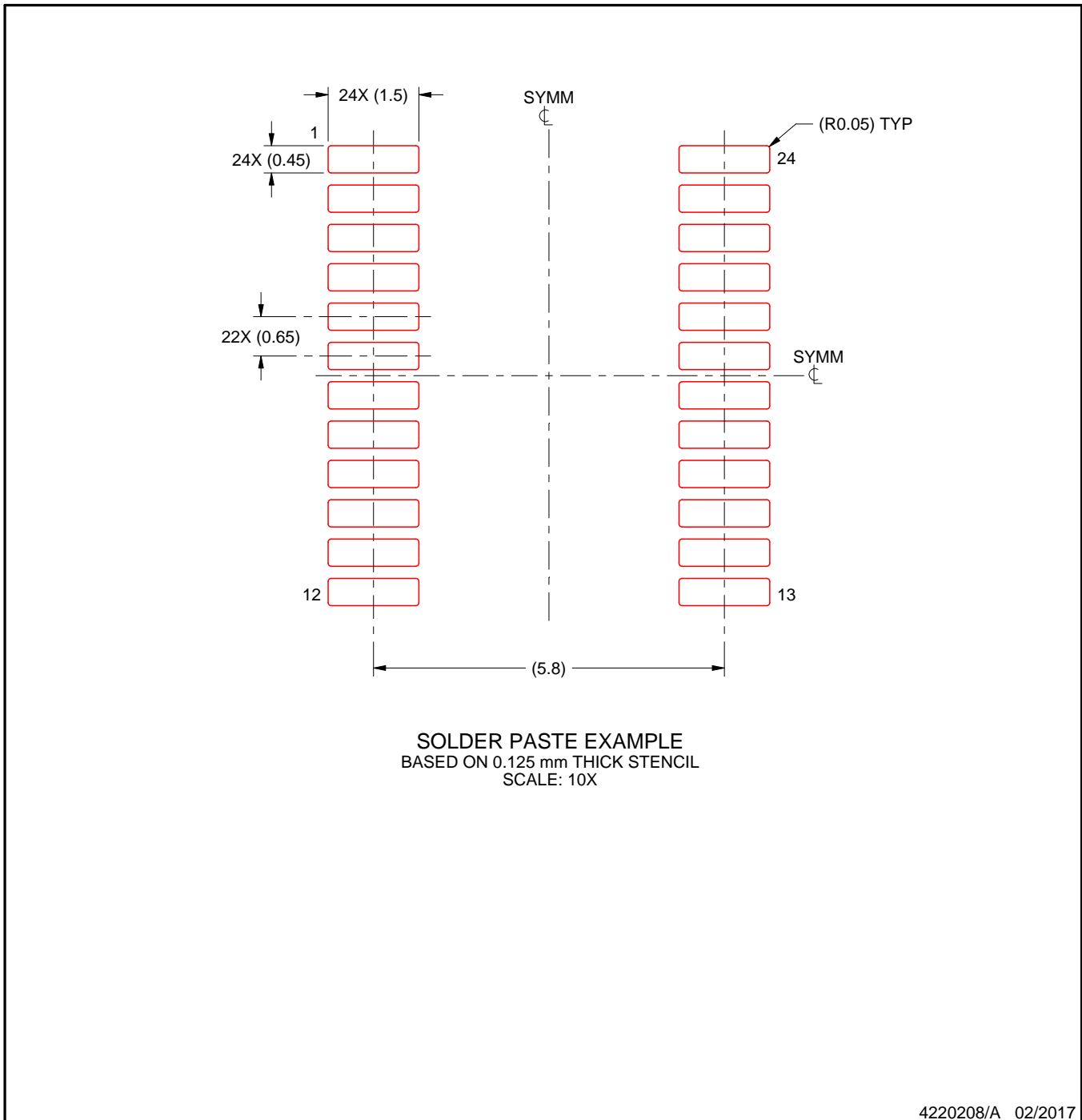

NOTES: (continued)

8. Laser cutting apertures with trapezoidal walls and rounded corners may offer better paste release. IPC-7525 may have alternate design recommendations.
9. Board assembly site may have different recommendations for stencil design.

IMPORTANT NOTICE AND DISCLAIMER

TI PROVIDES TECHNICAL AND RELIABILITY DATA (INCLUDING DATASHEETS), DESIGN RESOURCES (INCLUDING REFERENCE DESIGNS), APPLICATION OR OTHER DESIGN ADVICE, WEB TOOLS, SAFETY INFORMATION, AND OTHER RESOURCES "AS IS" AND WITH ALL FAULTS, AND DISCLAIMS ALL WARRANTIES, EXPRESS AND IMPLIED, INCLUDING WITHOUT LIMITATION ANY IMPLIED WARRANTIES OF MERCHANTABILITY, FITNESS FOR A PARTICULAR PURPOSE OR NON-INFRINGEMENT OF THIRD PARTY INTELLECTUAL PROPERTY RIGHTS.

These resources are intended for skilled developers designing with TI products. You are solely responsible for (1) selecting the appropriate TI products for your application, (2) designing, validating and testing your application, and (3) ensuring your application meets applicable standards, and any other safety, security, or other requirements. These resources are subject to change without notice. TI grants you permission to use these resources only for development of an application that uses the TI products described in the resource. Other reproduction and display of these resources is prohibited. No license is granted to any other TI intellectual property right or to any third party intellectual property right. TI disclaims responsibility for, and you will fully indemnify TI and its representatives against, any claims, damages, costs, losses, and liabilities arising out of your use of these resources.

TI's products are provided subject to TI's Terms of Sale (www.ti.com/legal/termsofsale.html) or other applicable terms available either on ti.com or provided in conjunction with such TI products. TI's provision of these resources does not expand or otherwise alter TI's applicable warranties or warranty disclaimers for TI products.

Mailing Address: Texas Instruments, Post Office Box 655303, Dallas, Texas 75265
Copyright © 2019, Texas Instruments Incorporated

Looking for pricing, stock, or lifecycle information?

Click below to explore more details on WIN SOURCE:

 [View PCA9548ADWR](#) on WIN SOURCE

 [Texas Instruments](#) Information

Optimize Your Supply Chain with WIN SOURCE Solutions

-  Global Sourcing Solution
-  Obsolete Management
-  Cost Control Management
-  Shortage Management
-  Alternative Solution
-  Excess Inventory Management