



**THE DATASHEET OF
BQ500410ARGZT**



bq500410A Free Positioning, Qi-Compliant Wireless Power Transmitter Manager

Not Recommended for New Designs

1 Features

- Expanded Free Positioning Using Three-Coil Transmit Array
- Intelligent Control of Wireless Power Transfer
- Conforms to Wireless Power Consortium (WPC) A6 Transmitter Specification
- Digital Demodulation Reduces Components
- WPC1.1 Ready, Including Foreign Object Detection (FOD)
- Enhanced Parasitic Metal Detection (PMOD) Assures Safety
- Overcurrent Protection
- LED Indication of Charging State and Fault Status

2 Applications

- WPC 1.1 Ready Wireless Chargers for:
 - Smart Phones and Other Handhelds
 - Hermetically Sealed Devices and Tools
 - Cars and Other Vehicles
 - Tabletop Charge Surfaces
- See www.ti.com/wirelesspower for More Information on TI's Wireless Charging Solutions

3 Description

The bq500410A device is a free-positioning digital wireless power controller that integrates all functions required to control wireless power transfer to a WPC compliant receiver. It is WPC 1.1 ready and designed for 12-V systems but applicable to other supply voltages. The bq500410A *pings* the surrounding environment for WPC compliant devices to be powered, safely engages the device, reads the packet feedback from the powered device, and manages the power transfer. A charging area of at least 70 mm × 20 mm provides flexible receiver placement on a transmitter pad. The bq500410A supports both Parasitic Metal Detection (PMOD) and Foreign Object Detection (FOD) by continuously monitoring the efficiency of the established power transfer, protecting from power lost due to metal objects misplaced in the wireless power transfer path. Should any abnormal condition develop during power transfer, the bq500410A handles it and provides fault indicator outputs. Comprehensive protection features provide a robust design to protect the system in all receiver placements.

The bq500410A is available in an area-saving 48-pin, 7-mm × 7-mm VQFN package and operates over a temperature range from –40°C to 110°C.

Device Information⁽¹⁾

PART NUMBER	PACKAGE	BODY SIZE (NOM)
bq500410A	VQFN (48)	7.00 mm × 7.00 mm

(1) For all available packages, see the orderable addendum at the end of the data sheet.

Functional Diagram

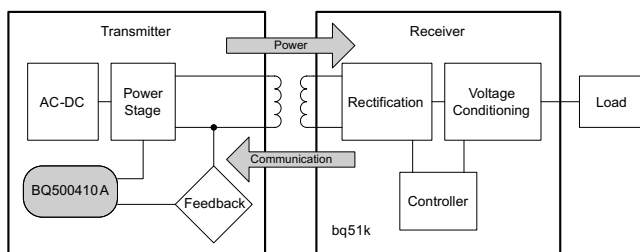

Efficiency Vs System Output Current

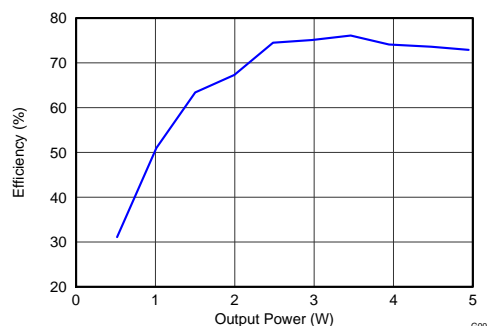

Table of Contents

1 Features	1	7.3 Feature Description.....	9
2 Applications	1	8 Application and Implementation	16
3 Description	1	8.1 Typical Application	16
4 Revision History	2	8.2 System Examples	18
5 Pin Configuration and Functions	3	9 Layout	20
6 Specifications	5	9.1 Layout Guidelines	20
6.1 Absolute Maximum Ratings	5	10 Device and Documentation Support	21
6.2 Recommended Operating Conditions.....	5	10.1 Documentation Support	21
6.3 Thermal Information	5	10.2 Community Resources.....	21
6.4 Electrical Characteristics.....	5	10.3 Trademarks	21
7 Detailed Description	7	10.4 Electrostatic Discharge Caution.....	21
7.1 Overview	7	10.5 Glossary	21
7.2 Functional Block Diagram	9	11 Mechanical, Packaging, and Orderable Information	21

4 Revision History

Changes from Original (November 2012) to Revision A	Page
• Added <i>Feature Description</i> section, <i>Application and Implementation</i> section, <i>Layout</i> section, <i>Device and Documentation Support</i> section, and <i>Mechanical, Packaging, and Orderable Information</i> section.....	1

5 Pin Configuration and Functions

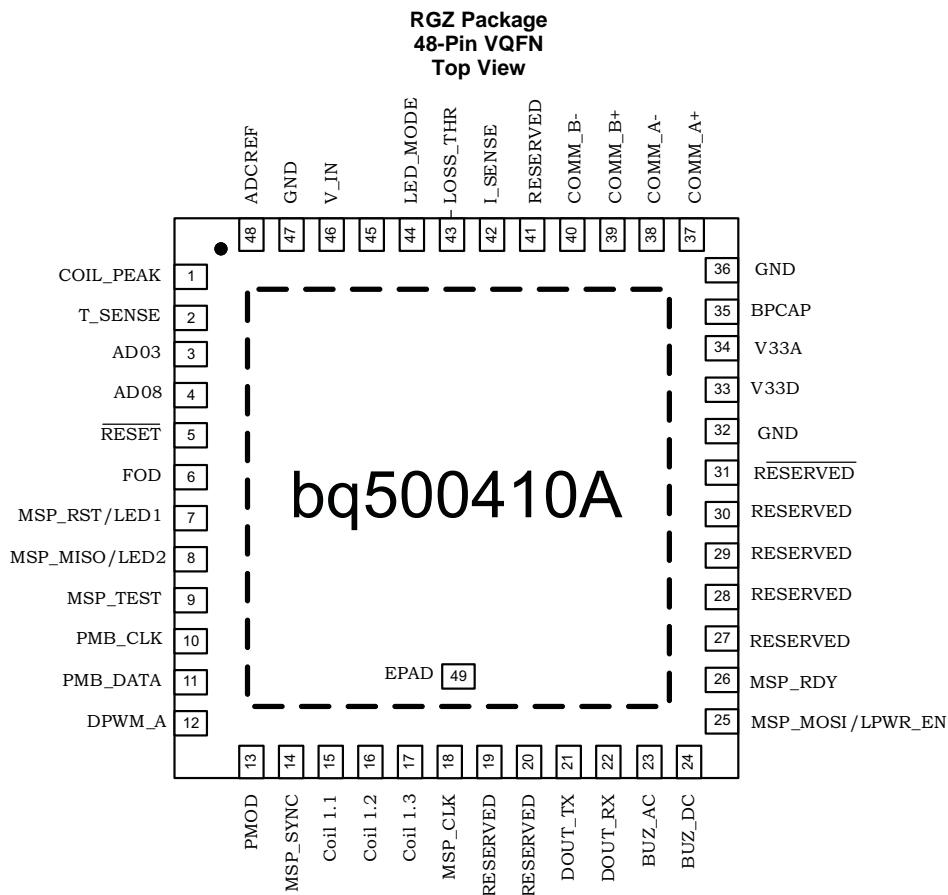

Pin Functions

PIN		I/O	DESCRIPTION
NAME	NO.		
AD03	3	I	This pin can be either connected to GND or left open. Connecting to GND can improve layout grounding.
AD08	4	I	Reserved. Connect to 3.3-V supply.
ADCREF	48	I	External reference voltage input. Connect this input to GND.
BPCAP	35	—	Bypass capacitor for internal 1.8-V core regulator. Connect bypass capacitor to GND.
BUZ_AC	23	O	AC buzzer output. A 400-ms, 4-kHz AC pulse train when charging begins.
BUZ_DC	24	O	DC buzzer output. A 400-ms DC pulse when charging begins. This could also be connected to an LED through 470-Ω resistor.
COIL 1.1	15	O	Enables the first coil drive train and COMM signal selector.
COIL 1.2	16	O	Enables the second coil drive train and COMM signal selector.
COIL 1.3	17	O	Enables the third coil drive train and COMM signal selector.
COIL_PEAK	1	I	Input from peak detect circuit.
COMM_A-	38	I	Digital demodulation inverting input A, connect parallel to input B-.
COMM_A+	37	I	Digital demodulation noninverting input A, connect parallel to input B+.
COMM_B-	40	I	Digital demodulation inverting input B, connect parallel to input A-.
COMM_B+	39	I	Digital demodulation noninverting input B, connect parallel to input A+.
DOUT_RX	22	I	Reserved, leave this pin open.
DOUT_TX	21	I	Reserved, leave this pin open.

Pin Functions (continued)

PIN		I/O	DESCRIPTION
NAME	NO.		
DPWM_A	12	O	PWM Output to half bridge driver. Switching dead times must be externally generated.
EPAD	49	—	Flood with copper GND plane and stitch vias to PCB internal GND plane.
FOD	6	O	FOD read pin. Leave open unless PMOD and FOD thresholds need to be different. It controls the FOD threshold resistor read at startup.
GND	32	—	GND
GND	36	—	GND
GND	47	—	GND
I_SENSE	42	I	Transmitter input current, used for parasitic loss calculations. Use 20-mΩ sense resistor and A=50 gain current sense amp.
LED_MODE	44	I	LED Mode Select.
LOSS_THR	43	I	Input to program foreign metal object detection (FOD) threshold.
MSP_CLK	18	I/O	MSP430 JTAG_CLK, SPI_CLK. Used for boot loading the MSP430 supervisor.
MSP_MISO/LED2	8	I	A dual function pin. MSP – MISO provided serial communication to the external supervisor. LED2 -- If external MSP430 is not used, connect to a (red) LED through 470-Ω resistor for status indication. Grounding pin 25 determines this pin's function.
MSP_MOSI/LPWR_EN	25	I/O	MSP-TDI, SPI-MOSI, Low Standby Power Supervisor Enable. Connect to GND if separate MSP430 low power supervisor is not used.
MSP_RDY	26	I/O	MSP_RDY, MSP430 Programmed Indication.
MSP_RST/LED1	7	I	A dual function pin. MSP – RST provides serial communication to the external supervisor. LED1 -- If external MSP430 is not used, connect to a (green) LED through 470-Ω resistor for status indication. Grounding pin 25 determines this pin's function.
MSP_SYNC	14	O	MSP SPI_SYNC, If external MSP430 is not used, leave this pin open.
MSP_TEST	9	I	MSP – Test, If external MSP430 is not used, leave this pin open.
PMB_CLK	10	I/O	10-kΩ pullup resistor to 3.3-V supply. I ² C/PMBus is for factory use only.
PMB_DATA	11	I/O	10-kΩ pullup resistor to 3.3-V supply. I ² C/PMBus is for factory use only.
PMOD	13	O	PMOD read pin. Leave open unless PMOD and FOD thresholds need to be different. It controls the PMOD threshold resistor read at startup.
RESERVED	19	O	Reserved, leave this pin open.
RESERVED	20	I	Reserved, connect to GND.
RESERVED	27	I/O	Reserved, leave this pin open.
RESERVED	28	I/O	Reserved, leave this pin open.
RESERVED	29	I/O	Reserved, leave this pin open.
RESERVED	30	I/O	Reserved, leave this pin open.
RESERVED	41	I	Reserved, leave this pin open.
RESERVED	31	I/O	Reserved, connect 10-kΩ pulldown resistor to GND. Do not leave open.
RESET	5	I	Device reset. Use 10-kΩ to 100-kΩ pullup resistor to 3.3-V supply.
T_SENSE	2	I	Sensor input. Device shuts down when below 1 V. If not used, keep above 1 V by simply connecting to 3.3-V supply.
V33A	34	—	Analog 3.3-V supply. This pin can be derived from V33D supply, decouple with 22-Ω resistor and additional bypass capacitors.
V33D	33	—	Digital Core 3.3-V supply. Be sure to decouple with bypass capacitors as close to the part as possible.
V_IN	46	I	System input voltage selector. Connect this input to GND for 12-V operation.
V_SENSE	45	I	Transmitter power train input voltage, used for FOD and Loss calculations. Voltage sample point should be after current input sense resistor. Use 76.8-kΩ to 10-kΩ divider to minimize quiescent loss.

6 Specifications

6.1 Absolute Maximum Ratings⁽¹⁾

over operating free-air temperature range (unless otherwise noted)

	MIN	MAX	UNIT
Voltage applied at V33D to DGND	-0.3	3.6	V
Voltage applied at V33A to AGND	-0.3	3.6	
Voltage applied to any pin ⁽²⁾	-0.3	3.6	
Storage temperature, T _{STG}	-40	150	°C

(1) Stresses beyond those listed under *Absolute Maximum Ratings* may cause permanent damage to the device. These are stress ratings only and functional operation of the device at these or any other conditions beyond those indicated under *Recommended Operating Conditions* is not implied. Exposure to absolute-maximum-rated conditions for extended periods may affect device reliability.

(2) All voltages referenced to GND.

6.2 Recommended Operating Conditions

over operating free-air temperature range (unless otherwise noted)

	MIN	NOM	MAX	UNIT
V Supply voltage during operation, V33D, V33A	3.0	3.3	3.6	V
T _A Operating free-air temperature range	-40		110	°C
T _J Junction temperature			110	

6.3 Thermal Information

THERMAL METRIC ⁽¹⁾		bq500410A		UNIT
		RGZ [VQFN]		
		48 PINS		
R _{θJA}	Junction-to-ambient thermal resistance	27.1		°C/W
R _{θJC(top)}	Junction-to-case (top) thermal resistance	12.9		°C/W
R _{θJB}	Junction-to-board thermal resistance	4.3		°C/W
ψ _{JT}	Junction-to-top characterization parameter	0.2		°C/W
ψ _{JB}	Junction-to-board characterization parameter	4.3		°C/W
R _{θJC(bot)}	Junction-to-case (bottom) thermal resistance	0.6		°C/W

(1) For more information about traditional and new thermal metrics, see the *Semiconductor IC Package Thermal Metrics* application report, [SPRA953](#).

6.4 Electrical Characteristics

over operating free-air temperature range (unless otherwise noted)

PARAMETER		TEST CONDITIONS	MIN	TYP	MAX	UNIT
SUPPLY CURRENT						
I _{V33A}	Supply current	V33A = 3.3 V		8	15	mA
I _{V33D}		V33D = 3.3 V		42	55	
I _{Total}		V33D = V33A = 3.3 V		52	60	
INTERNAL REGULATOR CONTROLLER INPUTS/OUTPUTS						
V33	3.3-V linear regulator	Emitter of NPN transistor	3.25	3.3	3.6	V
V33FB	3.3-V linear regulator feedback			4	4.6	
I _{V33FB}	Series pass base drive	V _{IN} = 12 V; current into V33FB pin		10		mA
Beta	Series NPN pass device		40			
EXTERNALLY SUPPLIED 3.3 V POWER						
V33D	Digital 3.3-V power	T _A = 25°C	3		3.6	V
V33A	Analog 3.3-V power	T _A = 25°C	3		3.6	
V33Slew	3.3-V slew rate	3.3-V slew rate between 2.3 V and 2.9 V, V33A = V33D	0.25			V/ms
DIGITAL DEMODULATION INPUTS: COMM_A+, COMM_A-, COMM_B+, COMM_B-						

bq500410A

SLUSB96A –NOVEMBER 2012–REVISED DECEMBER 2015

www.ti.com

Electrical Characteristics (continued)

over operating free-air temperature range (unless otherwise noted)

PARAMETER		TEST CONDITIONS	MIN	TYP	MAX	UNIT
V _{CM}	Common mode voltage each pin		-0.15		1.631	V
COMM+, COMM-	Modulation voltage digital resolution			1		mV
R _{EA}	Input Impedance	Ground reference	0.5	1.5	3	MΩ
I _{OFFSET}	Input offset current	1-kΩ source impedance	-5		5	μA
ANALOG INPUTS: V_IN, V_SENSE, I_SENSE, T_SENSE, LED_MODE, LOSS_THR						
V _{ADC_OPEN}	Voltage indicating open pin	LED_MODE, LOSS_THR open	2.37			V
V _{ADC_SHORT}	Voltage indicating pin shorted to GND	LED_MODE, LOSS_THR shorted to ground			0.36	
V _{ADC_RANGE}	Measurement range for voltage monitoring	ALL ANALOG INPUTS	0		2.5	
INL	ADC integral nonlinearity		-2.5		2.5	mV
I _{lkg}	Input leakage current	3 V applied to pin			100	nA
R _{IN}	Input impedance	Ground reference	8			MΩ
C _{IN}	Input capacitance				10	pF
DIGITAL INPUTS/OUTPUTS						
V _{OL}	Low-level output voltage	I _{OL} = 6 mA , V _{33D} = 3 V			DGND1 + 0.25	V
V _{OH}	High-level output voltage	I _{OH} = -6 mA , V _{33D} = 3 V	V _{33D} - 0.6 V			
V _{IH}	High-level input voltage	V _{33D} = 3 V	2.1		3.6	
V _{IL}	Low-level input voltage	V _{33D} = 3.5 V			1.4	
I _{OH(MAX)}	Output high source current				4	
I _{OL(MAX)}	Output low sink current				4	mA
SYSTEM PERFORMANCE						
V _{RESET}	Voltage where device comes out of reset	V _{33D} Pin	2.3		2.4	V
t _{RESET}	Pulse width needed for reset	$\overline{\text{RESET}}$ pin	2			μs
f _{SW}	Switching Frequency		112		205	kHz
t _{detect}	Time to detect presence of device requesting power				0.5	s

7 Detailed Description

7.1 Overview

7.1.1 Fundamentals

The principle of wireless power transfer is simply an open-cored transformer consisting of a transmitter and receiver coils. The transmitter coil and electronics are typically built into a charger pad and the receiver coil and electronics are typically built into a portable device, such as a cell phone.

When the receiver coil is positioned on the transmitter coil, magnetic coupling occurs once the transmitter coil is driven. The flux is coupled into the secondary coil which induces a voltage and current flows. The secondary voltage is rectified, and power can be transferred effectively to a load, wirelessly. Power transfer can be managed through any of various familiar closed-loop control schemes.

7.1.2 Wireless Power Consortium (WPC)

The Wireless Power Consortium (WPC) is an international group of companies from diverse industries. The WPC Standard was developed to facilitate cross-compatibility of compliant transmitters and receivers. The standard defines the physical parameters and the communication protocol to be used in wireless power. For more information, or to download a copy of the WPC specification, go to <http://www.wirelesspowerconsortium.com>.

7.1.3 Power Transfer

Power transfer depends on coil coupling. Coupling is dependant on the distance between coils, alignment, coil dimensions, coil materials, number of turns, magnetic shielding, impedance matching, frequency, and duty cycle.

Most importantly, the receiver and transmitter coils must be aligned for best coupling and efficient power transfer. The closer the space between the coils is, the better the coupling. However, the practical distance is set to be less than 5 mm, as defined within the WPC Specification, to account for housing and interface surfaces.

Shielding is added as a backing to both the transmitter and receiver coils to direct the magnetic field to the coupled zone. Magnetic fields outside the coupled zone do not transfer power. Thus, shielding also serves to contain the fields to avoid coupling to other adjacent system components.

Regulation can be achieved by controlling any one of the coil coupling parameters. However, for WPC compatibility, the transmitter-side coils and capacitance are specified and the resonant frequency point is fixed. Power transfer is thus regulated by changing the frequency along the resonance curve from 112 kHz to 205 kHz, (that is, the higher the frequency is, the lower the power). Duty cycle remains constant at 50% throughout the power band and is reduced only once 205 kHz is reached.

The WPC standard describes the dimensions, materials of the coils and information regarding the tuning of the coils to resonance. The value of the inductor and resonant capacitor are critical to proper operation and system efficiency.

7.1.4 Communication

Communication within the WPC is from the receiver to the transmitter, where the receiver tells the transmitter to send power and how much. In order to regulate, the receiver must communicate with the transmitter whether to increase or decrease frequency. The receiver monitors the rectifier output and using Amplitude Modulation (AM), sends packets of information to the transmitter. A packet is comprised of a preamble, a header, the actual message, and a checksum, as defined by the WPC standard.

The receiver sends a packet by modulating an impedance network. This AM signal reflects back as a change in the voltage amplitude on the transmitter coil. The signal is demodulated and decoded by the transmitter-side electronics and the frequency of its coil-drive output is adjusted to close the regulation loop. The bq500410A device features internal digital demodulation circuitry.

The modulated impedance network on the receiver can either be resistive or capacitive. [Figure 1](#) shows the resistive modulation approach, where a resistor is periodically added to the load, [Figure 2](#) shows the resulting amplitude change in the transmitter voltage. [Figure 2](#) shows the capacitive modulation approach, where a capacitor is periodically added to the load and the resulting amplitude change in the transmitter voltage.

Overview (continued)

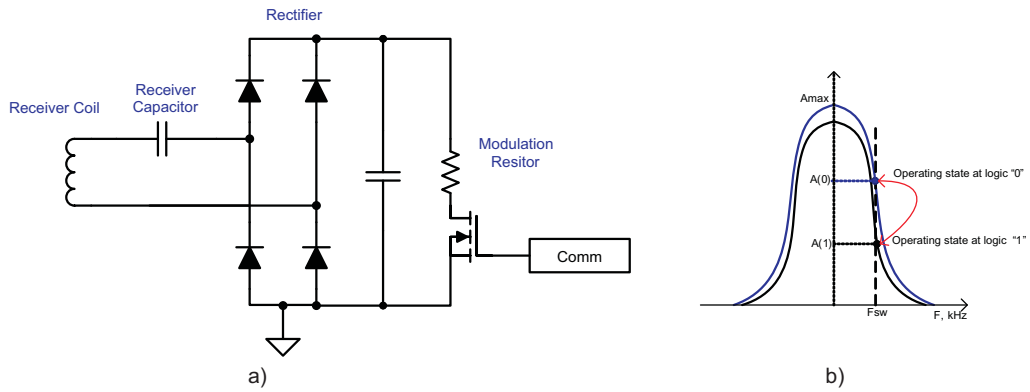

Figure 1. Receiver Resistive Modulation Circuit

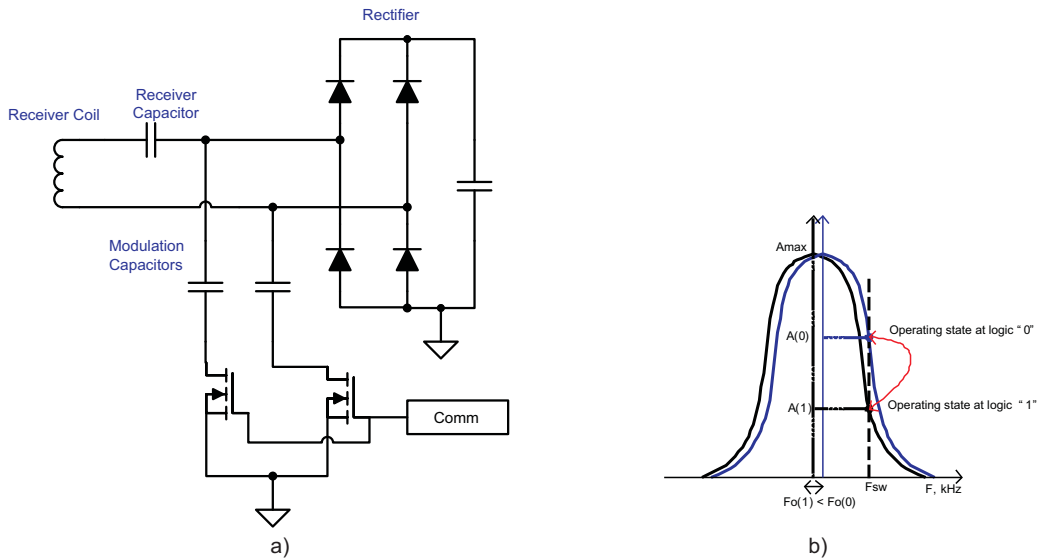
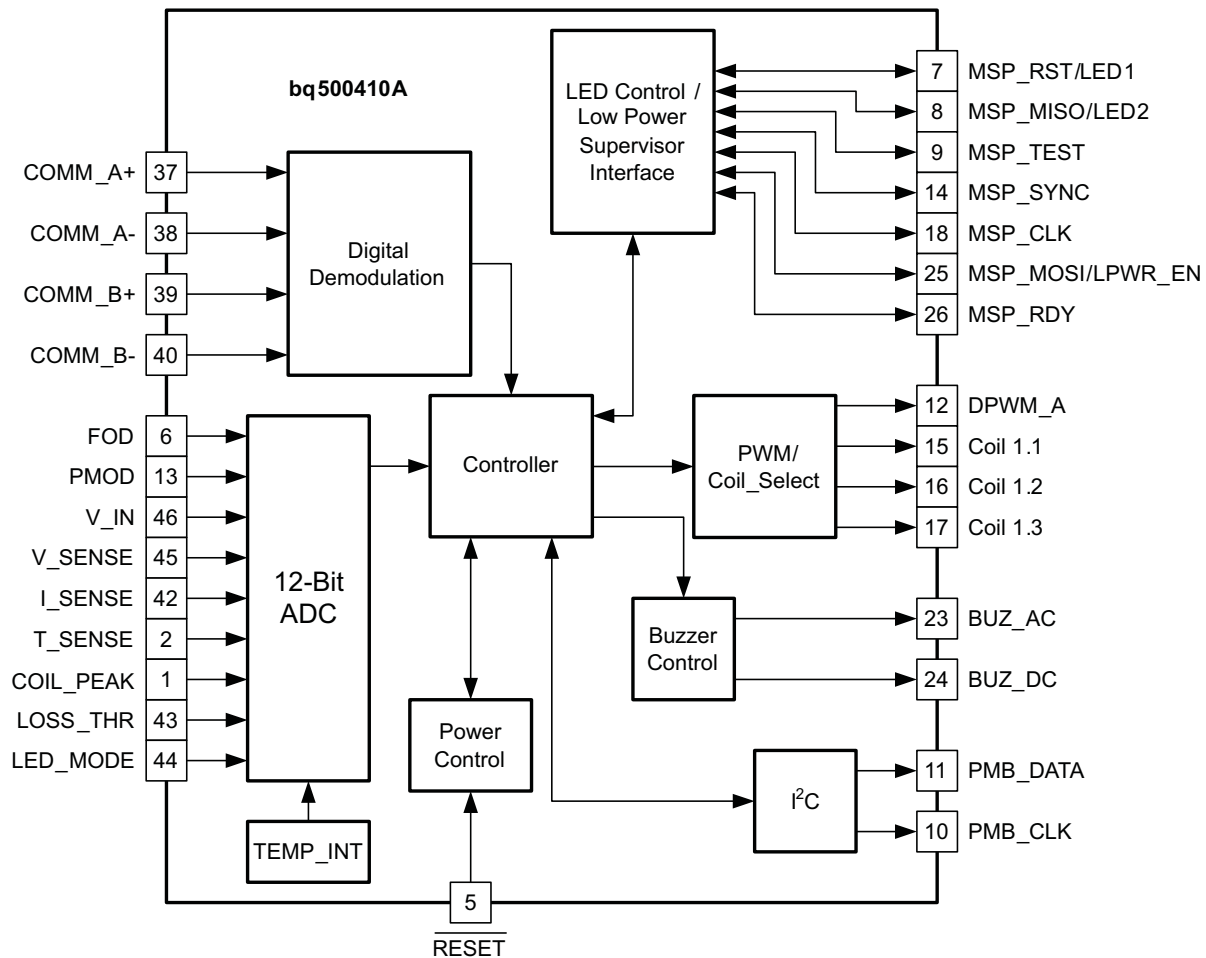

Figure 2. Receiver Capacitive Modulation Circuit

7.2 Functional Block Diagram



7.3 Feature Description

The bq500410A pings the surroundings in 400-ms intervals by sequentially firing the three coils in the array. The COMM feedback signal is multiplexed through analog switches and is synchronized to the coil being driven. To select the best coil match, the bq500410A looks for the strongest COMM signal. The coil is engaged and driven, note that only one coil is driven at a time. The driven coil is tolerant of slight misalignment of the RX while power is being transferred. Actually displacing the RX to an adjacent coil while charging is allowable, the sequential ping sequence and detection to determine the best matching coil to drive continues to repeat.

7.3.1 Capacitor Selection

Capacitor selection is critical to proper system operation. The total capacitance value of $2\text{ nF} \times 68\text{ nF}$ (+5.6-nF center coil) is required in the resonant tank. This is the WPC system compatibility requirement, not a guideline.

NOTE

A total capacitance value of $2\text{ nF} \times 68\text{ nF}/100\text{ V}$ ($68\text{ nF} + 5.6\text{ nF}$ center coil) (C0G dielectric type) is required in the resonant tank to achieve the correct resonance frequency.

The capacitors chosen must be rated for at least 100 V and must be of a high quality C0G dielectric (sometimes also called NP0). These are typically available in a 5% tolerance, which is adequate. The use of X7R types or below is not recommended if WPC compliance is required because critical WPC Certification Testing, such as the minimum modulation or ensured power requirements, might fail.

bq500410A

SLUSB96A –NOVEMBER 2012–REVISED DECEMBER 2015

www.ti.com

Feature Description (continued)

The designer can combine capacitors to achieve the desired capacitance value. Various combinations can work depending on market availability. All capacitors must be of C0G types, not mixed with any other dielectric types.

7.3.2 A6 Coil Specification

The coil and matching capacitor specification for the A6 transmitter has been established by WPC Standard. This is fixed and cannot be changed on the transmitter side.

The bq500410A is primarily intended to drive a 3-coil array but it can also be used to drive a single coil. For single coil operation the two outer coils and associated electronics are simply omitted. Please refer to [Figure 6](#).

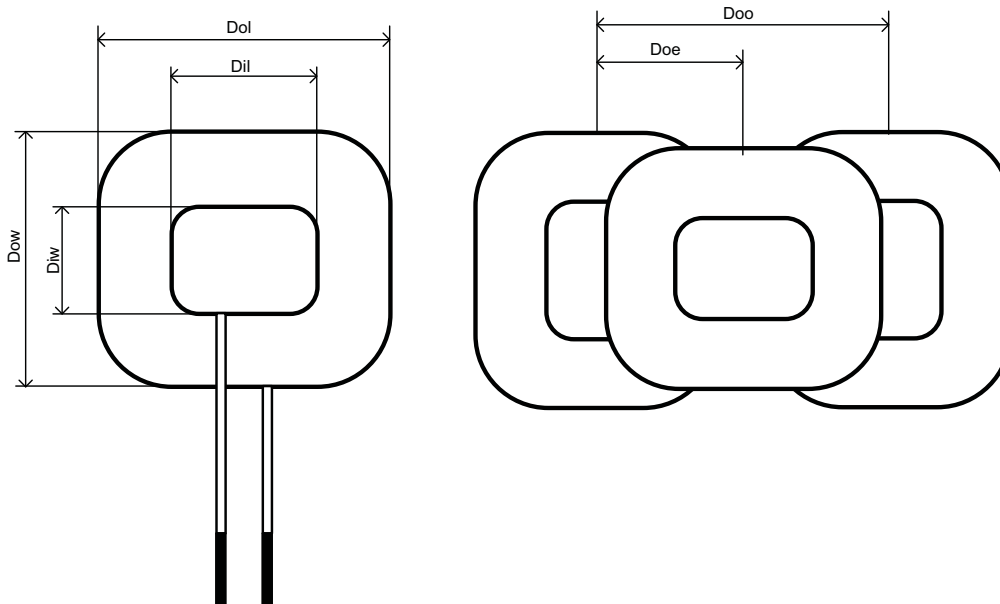

Figure 3. Coil Specification Drawing

Table 1. Coil Specification

PARAMETER	SYMBOL	SPECIFICATION	UNIT
Outer length	Dol	53.2, (± 0.5)	mm
Inner length	Dil	27.5, (± 0.5)	
Outer width	Dow	45.2, (± 0.5)	
Inner width	Diw	19.5, (± 0.5)	
Thickness	Dc	1.5, (± 0.5)	
Turns	N	12	Turns
Layers	-	1	
Odd displacement	Doo	49.2, (± 4)	mm
Even displacement	Doe	24.6, (± 2)	

NOTE

The performance of an A6 transmitter can vary based on the design of the A6 coil set. For best performance with small receiver coils under heavy loading, it is best to design the coil set such that the Doo dimension is on the low end of the specified tolerance.

For a current list of coil vendors, please see:

- *bqTESLA Transmitter Coil Vendors*, [SLUA649](#)

7.3.3 Option Select Pins

Two pins (pin 43 and pin 44) on the bq500410A are allocated to program the Loss Threshold and the LED mode of the device. At power up, a bias current is applied to pins LED_MODE and LOSS_THR and the resulting voltage measured in order to identify the value of the attached programming resistor. The values of the operating parameters set by these pins are determined using Table 3. For LED_MODE, the selected bin determines the LED behavior based on Table 2; for the LOSS_THR, the selected bin sets a threshold used for parasitic metal object detection (see Parasitic Metal Detection (PMOD) and Foreign Object Detection (FOD) section).

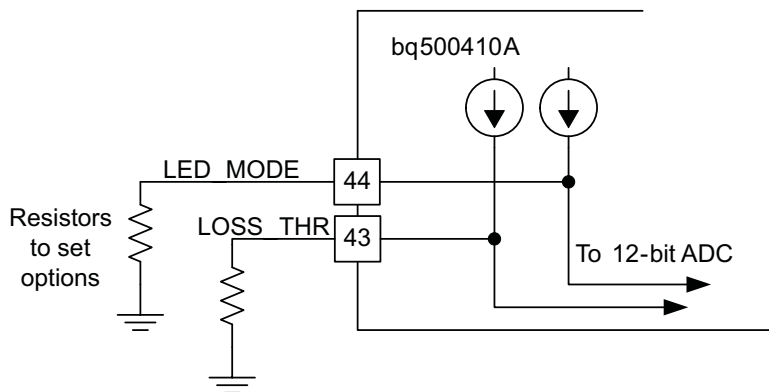

Figure 4. Option Programming

7.3.4 LED Modes

The bq500410A device can directly drive two LED outputs (pin 7 and pin 8) through a simple current limit resistor (typically 470 Ω), based on the mode selected. The two current limit resistors can be individually adjusted to tune or match the brightness of the two LEDs. Do not exceed the maximum output current rating of the device.

The selection resistor connected between pin 44 and GND selects one of the desired LED indication schemes presented in Table 2.

Table 2. LED Modes

LED CONTROL OPTION	LED SELECTION RESISTOR	DESCRIPTION	LED	OPERATIONAL STATES				
				STANDBY	POWER TRANSFER	CHARGE COMPLETE	FAULT	PMOD or FOD WARNING
0	<36.5 kΩ	LEDs off						
1	42.2 kΩ	Generic	LED1, Green	Off	Blink slow ⁽¹⁾	On	Off	Off
			LED2, Red	Off	Off	Off	On	Blink fast ⁽²⁾
2	48.7 kΩ	Generic + standby	LED1, Green	On	Blink slow ⁽¹⁾	On	Off	Off
			LED2, Red	On	Off	Off	On	Blink fast ⁽²⁾
3	56.2 kΩ	Generic Opt 1	LED1, Green	Off	Off	On	Off	Off
			LED2 Red	Off	On	Off	Blink fast ⁽²⁾	On
4	64.9 kΩ	Generic Opt 2	LED1, Green	Off	On	Off	Off	Off
			LED2 Red	Off	Off	Off	On	Blink fast ⁽²⁾
	> 75 kΩ	Reserved						

7.3.5 Parasitic Metal Object Detect (PMOD) and Foreign Object Detection (FOD)

The bq500410A is WPC1.1 ready and supports both enhanced PMOD and FOD features by continuously monitoring the input voltage and current to calculate input power. Combining input power, known losses, and the value of power reported by the RX device being charged, the bq500410A can estimate how much power is unaccounted for and presumed lost due to metal objects placed in the wireless power transfer path. If this unexpected loss exceeds the threshold set by the LOSS_THR resistor, a fault is indicated and power transfer is halted. Whether the PMOD or the FOD algorithm is used is determined by the ID packet of the receiver being charged.

(1) Blink slow = 0.625 Hz

(2) Blink fast = 2.5 Hz

bq500410A

SLUSB96A –NOVEMBER 2012–REVISED DECEMBER 2015

www.ti.com

PMOD has certain inherent weaknesses as rectified power is not ensured to be accurate per WPC1.0 Specification. The user has the flexibility to adjust the LOSS_THR resistor or to disable PMOD by leaving pin 43 open should issues with compliance or interoperability arise.

The FOD algorithm uses information from an in-system characterized and WPC1.1 certified RX and it is therefore more accurate. Where the WPC1.0 specification requires merely the Rectified Power packet, the WPC1.1 specification additionally uses the Received Power packet which more accurately tracks power used by the receiver.

As default, PMOD and FOD share the same LOSS_THR setting resistor for which the recommended starting point is 400 mW (selected by a 56.2-kΩ resistor on the LOSS_THR option pin 43). If, for some reason, the application requires disabling one or the other or setting separate PMOD and FOD thresholds, Figure 5 can be used.

Resistor R39 sets the FOD threshold and R24 sets the PMOD threshold in this configuration. The control lines (FOD and PMOD) are driven briefly at power-up when the resistor values are read.

To selectively disable PMOD support, R24 and Q8-B should be omitted from the above design.

Table 3. Option Select Bins

BIN NUMBER	RESISTANCE (kΩ)	LOSS THRESHOLD (mW)
0	<36.5	250
1	42.2	300
2	48.7	350
3	56.2	400
4	64.9	450
5	75.0	500
6	86.6	550
7	100	600
8	115	650
9	133	700
10	154	750
11	178	800
12	205	850
13	>237	Feature Disabled

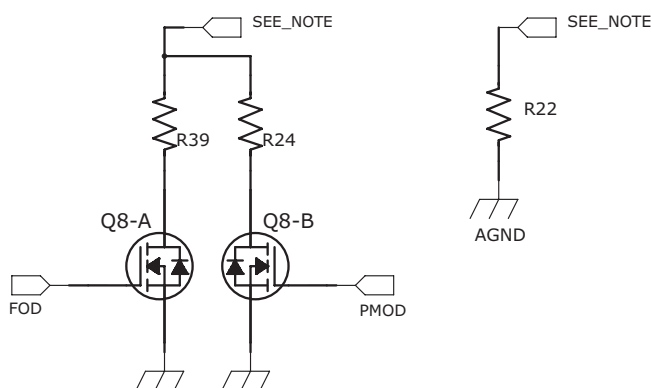

A. Either one of these circuits is connected to LOSS_THR, but not both.

Figure 5. LOSS_THR Connection Circuits

7.3.6 Shut Down by Thermal Sensor or Trigger

Typical applications of the bq500410A does not require additional thermal protection. This shutdown feature is provided for enhanced applications and is not limited to thermal shutdown. The key parameter is the 1.0-V threshold on pin 2. Voltage below 1.0 V on pin 2 causes the device to shut down.

The application of thermal monitoring via a Negative Temperature Coefficient (NTC) sensor, for example, is straightforward. The NTC forms the lower leg of a temperature dependant voltage divider. The NTC leads are connected to the bq500410A device, pin 2 and GND. The threshold on pin 2 is set to 1.0 V, below which the system shuts down and a fault is indicated (depending on LED mode chosen).

To implement this feature follow these steps:

1. Consult the NTC datasheet and find the resistance vs temperature curve.
2. Determine the actual temperature where the NTC will be placed by using a thermal probe.
3. Read the NTC resistance at that temperature in the NTC datasheet, that is $R_{_NTC}$.
4. Use the following formula to determine the upper leg resistor ($R_{_Setpoint}$):

$$R_{_Setpoint} = 2.3 \times R_{_NTC} \quad (1)$$

The system restores normal operation after approximately five minutes or if the receiver is removed. If the feature is not used, this pin must be pulled high.

NOTE

Pin 2 must always be terminated, else erratic behavior may result.

7.3.7 Fault Handling and Indication

The following is a table of End Power Transfer (EPT) packet responses, fault conditions, the duration how long the condition lasts until a retry is attempted. The LED mode selected determines how the LED indicates the condition or fault.

Table 4. Fault Handling and Indication

CONDITION	DURATION (before retry)	HANDLING
EPT-00	Immediate	Unknown
EPT-01	5 seconds	Charge complete
EPT-02	Infinite	Internal fault
EPT-03	5 minutes	Over temperature
EPT-04	Immediate	Over voltage
EPT-05	Immediate	Over current
EPT-06	Infinite	Battery failure
EPT-07	Not applicable	Reconfiguration
EPT-08	Immediate	No response
OVP (over voltage)	Immediate	
OC (over current)	1 minute	
NTC (external sensor)	5 minutes	
PMOD/FOD warning	12 seconds	10 seconds LED only, 2 seconds LED + buzzer
PMOD/FOD	5 minutes	

7.3.8 Power Transfer Start Signal

The bq500410A features two signal outputs to indicate that power transfer has begun. Pin 23 outputs a 400-ms duration, 4-kHz square wave for driving low-cost AC type ceramic buzzers. Pin 24 outputs logic high, also for 400 ms, which is suitable for DC type buzzers with built-in tone generators, or as a trigger for any type of customized indication scheme. Do not exceed 4-mA loading from either of these pins which is more than adequate for small signaling and actuation. If not used, these pins should be left open.

7.3.9 Power-On Reset

The bq500410A has an integrated Power-On Reset (POR) circuit which monitors the supply voltage and handles the correct device startup sequence. Additional supply voltage supervisor or reset circuits are not needed.

bq500410A

SLUSB96A –NOVEMBER 2012–REVISED DECEMBER 2015

www.ti.com

7.3.10 External Reset, $\overline{\text{RESET}}$ Pin

The bq500410A can be forced into a reset state by an external circuit connected to the $\overline{\text{RESET}}$ pin. A logic low voltage on this pin holds the device in reset. For normal operation, this pin is pulled up to 3.3 V_{CC} with a 10-k Ω pull-up resistor.

7.3.11 Trickle Charge and CS100

CS100 is supported. If CS100 is reported by the RX, the bq500410A indicates that charge is complete.

The WPC specification provides an End-of-Power Transfer message (EPT) to indicate charge complete. Upon receipt of the charge complete message, the bq500410A changes the LED indication to solid green LED output and halt power transfer for 5 seconds. Subsequently, transmitters pings the receiver again to see if its status has changed, assuming it receives another EPT, the LED mode stays the same.

The WPC specification also provides reporting of the level of battery charge (Charge Status). In some battery charging applications, there is a benefit to continue the charging process in trickle-charge mode to top off the battery. The bq500410A changes the LED indication to reflect charge complete when a 'Charge Status 100%' message is received, but unlike the response to an EPT message, it does not halt power transfer while the LED is solid green. The RX, the mobile device being charged, uses a CS100 packet to enable trickle charge mode.

7.3.12 Current Monitoring Requirements

The bq500410A is WPC1.1 ready. In order to enable the PMOD or FOD features, current monitoring must be provided in the design.

Current monitoring is optional however, it is used for the foreign metal protection features and over current protection. The system designer can choose not to include the current monitor and remain WPC1.0 compliant. Alternately, the additional current monitoring circuitry can be added to the hardware design but not loaded. This would enable a forward migration path to future WPC1.1 compatibility.

For proper scaling of the current monitor signal, the current sense resistor should be 20 m Ω and the current shunt amplifier should have a gain of 50, such as the INA199A1. The current sense resistor has a temperature stability of ± 200 PPM. Proper current sensing techniques in the application hardware should also be observed.

7.3.13 Overcurrent Protection

The bq500410A has an integrated current protection feature which monitors the input current reported by the current sense resistor and amplifier. If the input current exceeds a safety threshold, a fault is indicated and power transfer is halted for one minute.

If this feature is desired, the sense resistor and amplifier are required. If this feature is not desired, the I_SENSE input pin to the bq500410A (pin 42) should be grounded.

NOTE

Always terminate the I_SENSE pin (pin 42), either with the output of a current monitor circuit or by connecting to ground.

7.3.14 MSP430G2101 Low Power Supervisor

This is an optional low-power feature. By adding the MSP430G2101, as recommended in [Figure 6](#), the bq500410A device is periodically shut down to conserve power, yet all relevant states are recalled and all running LED status indicators remain active.

Since the bq500410A needs an external low-power mode to significantly reduce power consumption, the most direct way to reduce power is to remove its supply and completely shut it down. In doing so, however, the bq500410A goes through a reset and any data in memory would be lost. Important information regarding charge state, fault condition, operating mode, and indicator pins driven would be cleared.

The MSP430G2101, in its role as a low-power supervisor, is used to provide accurate 'ping' timing, retains charge state, operating mode, fault condition and all relevant operation states. The LEDs are now driven and controlled by the MSP430, not the bq500410A, which directly drives and maintains the LED status indication during the bq500410A reset periods. Since the LED indicators are now driven by the MSP430G2101, care should be taken not to exceed the pin output current drive limit.

Using the suggested circuitry, a standby power reduction from 300 mW to less than 90 mW can be expected making it possible to achieve Energy Star rating.

The user does not need to program the MSP430G2101, an off-the-shelf part can be used. The required MSP430G2101 firmware is embedded in the bq500410A and is boot loaded at first power up, similar to a field update. The MSP430G2101 code cannot be modified by the user.

NOTE

The user cannot program the MSP430G2101 in this system.

7.3.15 All Unused Pins

All unused pins can be left open unless otherwise indicated. Please refer to . Grounding of unused pins, if it is an option, can improve PCB layout.

8 Application and Implementation

NOTE

Information in the following applications sections is not part of the TI component specification, and TI does not warrant its accuracy or completeness. TI's customers are responsible for determining suitability of components for their purposes. Customers should validate and test their design implementation to confirm system functionality.

8.1 Typical Application

The application schematic for the transmitter with reduced standby power is shown in Figure 7.

CAUTION

Please check the bq500410A product page for the most up-to-date schematic and list of materials reference design package before starting a new project.

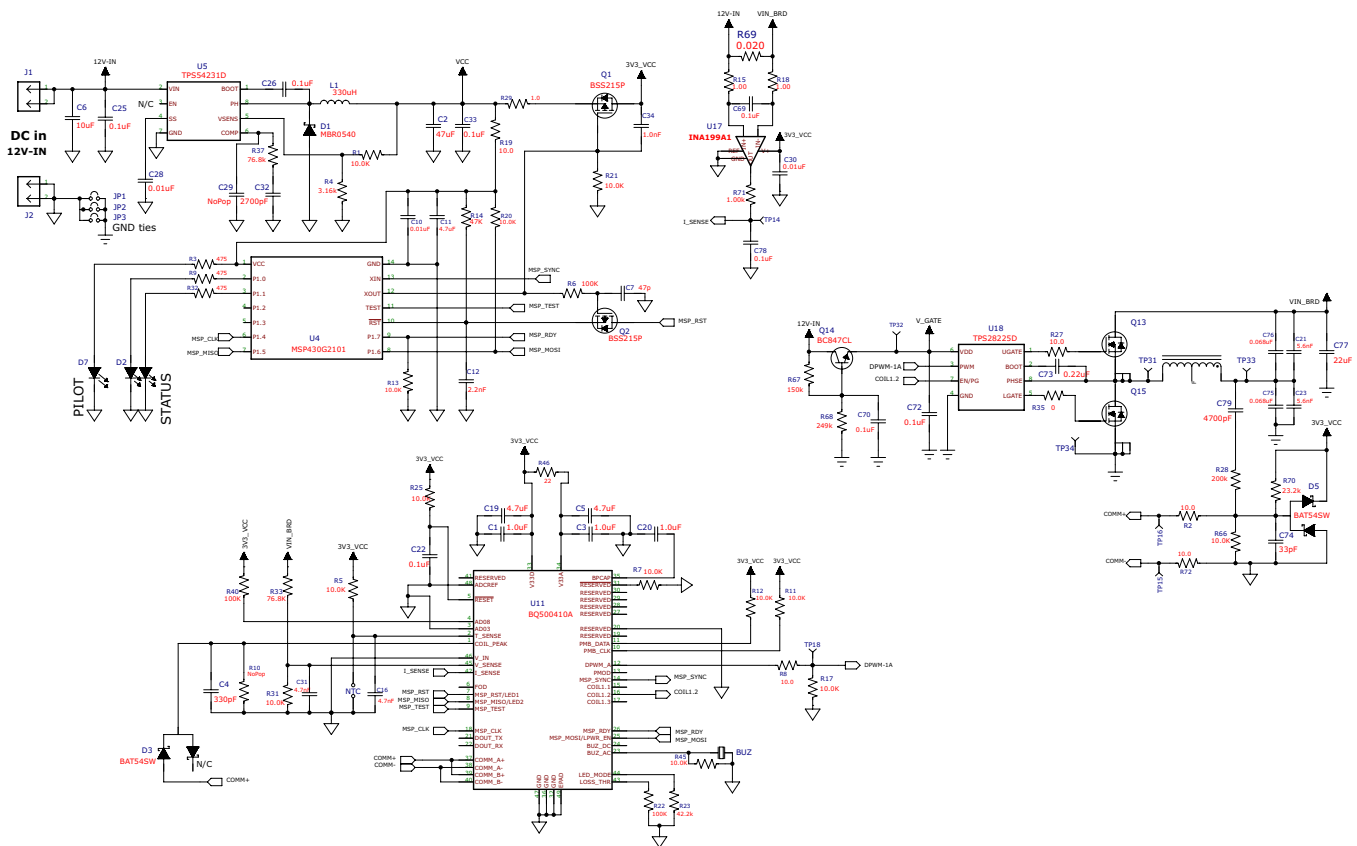

Figure 6. bq500410A Single Coil Application Diagram

8.1.1 Detailed Design Procedure

8.1.1.1 Input Regulator

The bq500410A requires 3.3 V_{DC} to operate. A buck regulator or a linear regulator can be used to step down from the 12-V system input. Either choice is fully WPC compatible, the decision lies in the user's requirements with respect to cost or efficiency.

Figure 6 utilizes a low-cost buck regulator, TPS54231.

Typical Application (continued)

8.1.1.2 Power Trains

The bq500410A drives three independent half bridges. Each half bridge drives one coil from the coil set assembly. The TPS28225 is the recommended driver device for this application. It features high-side drive capability which enables the use of N-channel MOSFETs throughout. Gate-drive supply can be derived from a primitive active voltage divider. A highly regulated supply is not required to drive MOSFET gates.

8.1.1.3 Signal Processing Components

The COMM signal used to control power transfer is derived from the coil voltage. Each coil has its own signal processing chain. The coil voltage is AC coupled and divided down to a manageable level and biased to a 1-V offset. Series connected diodes are provided for protection from any possible transients. The three signal processing chains are then multiplexed together via analog switches. Thus, the correct signal processing chain and COMM signal used to control power transfer is from the coil being driven.

8.1.1.4 Low-Power Supervisor

Power reduction is achieved by periodically disabling the bq500410A while LED and housekeeping control functions are continued by U4, the low-cost, low quiescent current micro controller MSP430G2101. When U4 is present in the circuit (which is set by a pull-up resistor on bq500410A pin 25), the bq500410A at first power-up boots the MSP430G2101 with the necessary firmware and the two chips operate in tandem. During standby operation, the bq500410A periodically issues SLEEP command, Q1 pulls the supply to the bq500410A, therefore eliminating its power consumption. Meanwhile, the MSP430G2101 maintains the LED indication and stores previous charge state during this bq500410A reset period. This bq500410A off period is set by the MSP430G2101. WPC compliance mandates the power transmitter controller, bq500410A, awakes every 400 ms to produce an analog ping and check if a valid device is present. This time constant can not be altered to further reduce power.

8.1.1.5 Disabling Low-Power Supervisor Mode

For lowest cost or if the low-power supervisor is not needed, please refer to [Figure 8](#) for an application schematic example.

8.1.1.6 Input Power Requirements

For full wireless power system capability and WPC compliance, the AC power adapter selected for the application should have a minimum rating of 12 V at 750 mA.

bq500410A

SLUSB96A –NOVEMBER 2012–REVISED DECEMBER 2015

www.ti.com

8.2 System Examples

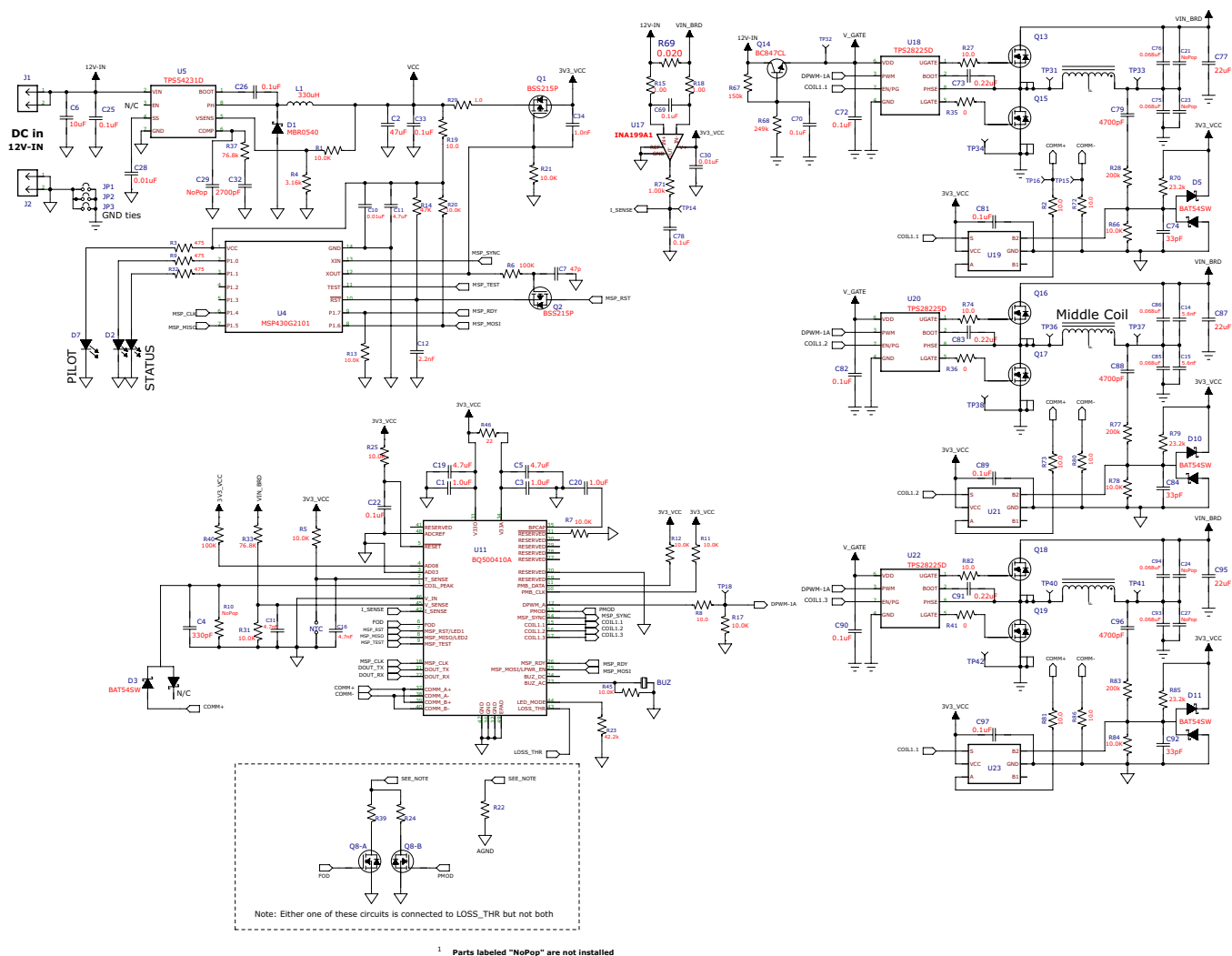

Figure 7. bq500410A Low-Power Application Diagram

System Examples (continued)

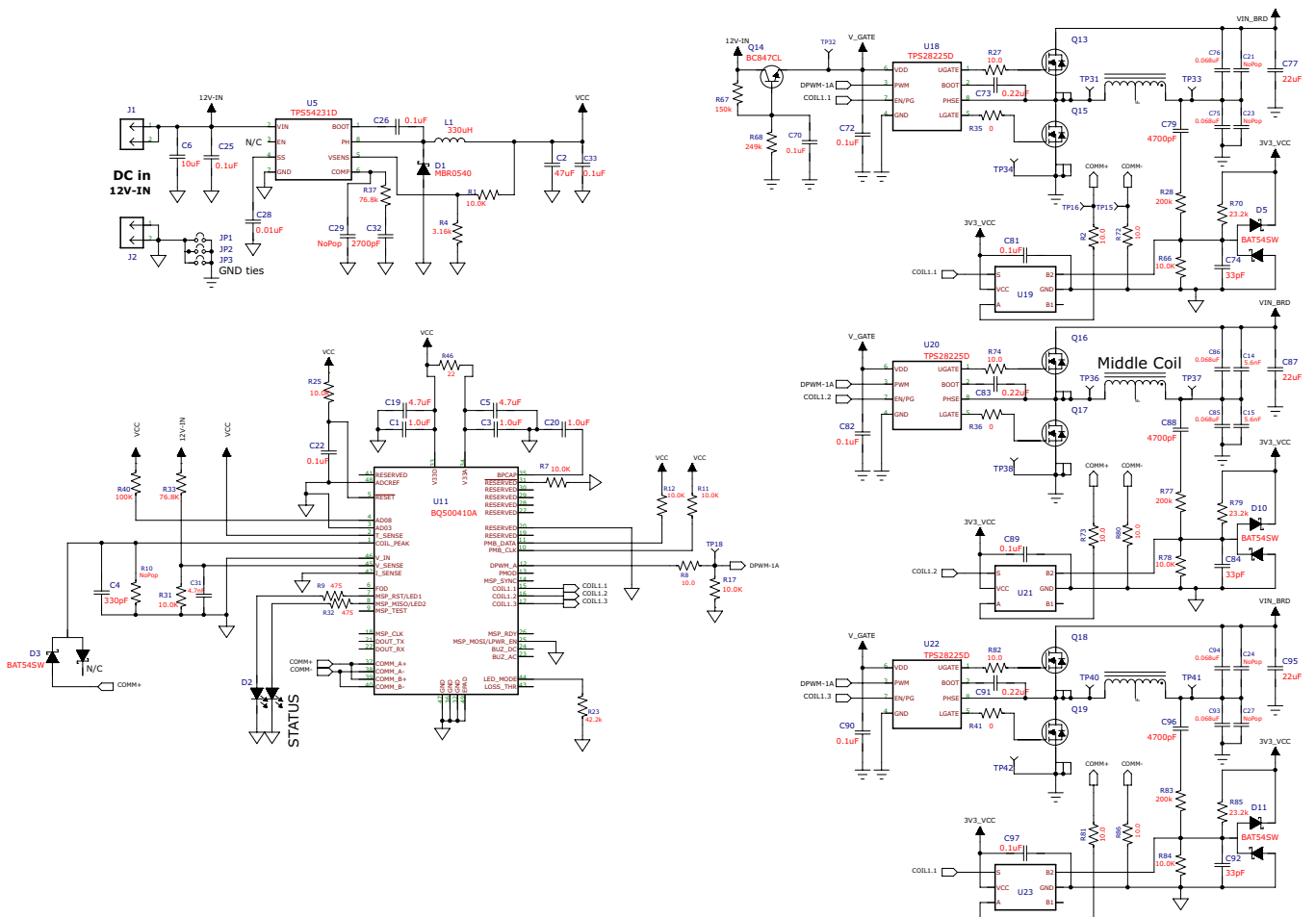

Figure 8. bq500410A Low-Cost Application Diagram

bq500410A

SLUSB96A –NOVEMBER 2012–REVISED DECEMBER 2015

www.ti.com

9 Layout

9.1 Layout Guidelines

Careful PCB layout practice is critical to proper system operation. There are many references on proper PCB layout techniques. A few good tips are repeated here:

The TX layout requires a 4-layer PCB layout for best ground plane technique. A 2-layer PCB layout can be achieved though not as easily. Ideally, the approach to the layer stack-up has been:

- Layer 1 component placement and as much ground plane as possible.
- Layer 2 clean ground.
- Layer 3 finish routing.
- Layer 4 clean ground.

Thus, the circuitry is virtually sandwiched between grounds. This minimizes EMI noise emissions and also provides a noise-free voltage reference plane for device operation.

Keep as much copper as possible. Make sure the bq500410A GND pins and the power pad have a continuous flood connection to the ground plane. The power pad should also be stitched to the ground plane, which also acts as a heat sink for the bq500410A. A good GND reference is necessary for proper bq500410A operation, such as analog-digital conversion, clock stability and best overall EMI performance.

Separate the analog ground plane from the power ground plane and use only ONE tie point to connect grounds. Having several tie points defeats the purpose of separating the grounds.

The COMM return signal from the resonant tank should be routed as a differential pair. This is intended to reduce stray noise induction. The frequencies of concern warrant low-noise analog signaling techniques, such as differential routing and shielding, but the COMM signal lines do not need to be impedance matched.

The DC-DC buck regulator used from the 12-V input supplies the bq500410A with 3.3 V. Typically a single-chip controller solution with integrated power FET and synchronous rectifier or outboard diode is used. Pull in the buck inductor and power loop as close as possible to create a tight loop. Likewise, the power-train, full-bridge components should be pulled together as tight as possible. See the bq500410A EVM for an example of a good layout technique.

10 Device and Documentation Support

10.1 Documentation Support

10.1.1 Related Documentation

For related documentation, see the following:

1. Technology, *Wireless Power Consortium*, <http://www.wirelesspowerconsortium.com/>
2. Analog Applications Journal, *An Introduction to the Wireless Power Consortium Standard and TI's Compliant Solutions*, Johns, Bill, (Texas Instruments Literature Number [SLYT401](#))
3. Datasheet, *Qi Compliant Wireless Power Transmitter Manager*, (Texas Instruments Literature Number [SLUSAL8](#))
4. Datasheet, *Integrated Wireless Power Supply Receiver, Qi (WPC) Compliant, bq51011, bq51013*, (Texas Instruments Literature Number [SLVSAT9](#))
5. Application Note, *Building a Wireless Power Transmitter*, (Texas Instruments Literature Number [SLUA635](#))
6. Application Note, *bqTESLA Transmitter Coil Vendors*, Texas Instruments Literature Number [SLUA649](#)

10.2 Community Resources

The following links connect to TI community resources. Linked contents are provided "AS IS" by the respective contributors. They do not constitute TI specifications and do not necessarily reflect TI's views; see TI's [Terms of Use](#).

TI E2E™ Online Community *TI's Engineer-to-Engineer (E2E) Community*. Created to foster collaboration among engineers. At e2e.ti.com, you can ask questions, share knowledge, explore ideas and help solve problems with fellow engineers.

Design Support *TI's Design Support* Quickly find helpful E2E forums along with design support tools and contact information for technical support.

10.3 Trademarks

E2E is a trademark of Texas Instruments.
All other trademarks are the property of their respective owners.

10.4 Electrostatic Discharge Caution



These devices have limited built-in ESD protection. The leads should be shorted together or the device placed in conductive foam during storage or handling to prevent electrostatic damage to the MOS gates.

10.5 Glossary

[SLYZ022](#) — *TI Glossary*.

This glossary lists and explains terms, acronyms, and definitions.

11 Mechanical, Packaging, and Orderable Information

The following pages include mechanical, packaging, and orderable information. This information is the most current data available for the designated devices. This data is subject to change without notice and revision of this document. For browser-based versions of this data sheet, refer to the left-hand navigation.

PACKAGING INFORMATION

Orderable Device	Status (1)	Package Type	Package Drawing	Pins	Package Qty	Eco Plan (2)	Lead/Ball Finish (6)	MSL Peak Temp (3)	Op Temp (°C)	Device Marking (4/5)	Samples
BQ500410ARGZR	NRND	VQFN	RGZ	48	2500	Green (RoHS & no Sb/Br)	CU NIPDAU	Level-3-260C-168 HR	-40 to 110	BQ500410A	
BQ500410ARGZT	NRND	VQFN	RGZ	48	250	Green (RoHS & no Sb/Br)	CU NIPDAU	Level-3-260C-168 HR	-40 to 110	BQ500410A	

(1) The marketing status values are defined as follows:

ACTIVE: Product device recommended for new designs.

LIFEBUY: TI has announced that the device will be discontinued, and a lifetime-buy period is in effect.

NRND: Not recommended for new designs. Device is in production to support existing customers, but TI does not recommend using this part in a new design.

PREVIEW: Device has been announced but is not in production. Samples may or may not be available.

OBSELETE: TI has discontinued the production of the device.

(2) Eco Plan - The planned eco-friendly classification: Pb-Free (RoHS), Pb-Free (RoHS Exempt), or Green (RoHS & no Sb/Br) - please check <http://www.ti.com/productcontent> for the latest availability information and additional product content details.

TBD: The Pb-Free/Green conversion plan has not been defined.

Pb-Free (RoHS): TI's terms "Lead-Free" or "Pb-Free" mean semiconductor products that are compatible with the current RoHS requirements for all 6 substances, including the requirement that lead not exceed 0.1% by weight in homogeneous materials. Where designed to be soldered at high temperatures, TI Pb-Free products are suitable for use in specified lead-free processes.

Pb-Free (RoHS Exempt): This component has a RoHS exemption for either 1) lead-based flip-chip solder bumps used between the die and package, or 2) lead-based die adhesive used between the die and leadframe. The component is otherwise considered Pb-Free (RoHS compatible) as defined above.

Green (RoHS & no Sb/Br): TI defines "Green" to mean Pb-Free (RoHS compatible), and free of Bromine (Br) and Antimony (Sb) based flame retardants (Br or Sb do not exceed 0.1% by weight in homogeneous material)

(3) MSL, Peak Temp. - The Moisture Sensitivity Level rating according to the JEDEC industry standard classifications, and peak solder temperature.

(4) There may be additional marking, which relates to the logo, the lot trace code information, or the environmental category on the device.

(5) Multiple Device Markings will be inside parentheses. Only one Device Marking contained in parentheses and separated by a "~" will appear on a device. If a line is indented then it is a continuation of the previous line and the two combined represent the entire Device Marking for that device.

(6) Lead/Ball Finish - Orderable Devices may have multiple material finish options. Finish options are separated by a vertical ruled line. Lead/Ball Finish values may wrap to two lines if the finish value exceeds the maximum column width.

Important Information and Disclaimer:The information provided on this page represents TI's knowledge and belief as of the date that it is provided. TI bases its knowledge and belief on information provided by third parties, and makes no representation or warranty as to the accuracy of such information. Efforts are underway to better integrate information from third parties. TI has taken and continues to take reasonable steps to provide representative and accurate information but may not have conducted destructive testing or chemical analysis on incoming materials and chemicals. TI and TI suppliers consider certain information to be proprietary, and thus CAS numbers and other limited information may not be available for release.

In no event shall TI's liability arising out of such information exceed the total purchase price of the TI part(s) at issue in this document sold by TI to Customer on an annual basis.

TAPE AND REEL INFORMATION

QUADRANT ASSIGNMENTS FOR PIN 1 ORIENTATION IN TAPE

*All dimensions are nominal

Device	Package Type	Package Drawing	Pins	SPQ	Reel Diameter (mm)	Reel Width W1 (mm)	A0 (mm)	B0 (mm)	K0 (mm)	P1 (mm)	W (mm)	Pin1 Quadrant
BQ500410ARGZR	VQFN	RGZ	48	2500	330.0	16.4	7.3	7.3	1.1	12.0	16.0	Q2
BQ500410ARGZR	VQFN	RGZ	48	2500	330.0	16.4	7.3	7.3	1.5	12.0	16.0	Q2
BQ500410ARGZT	VQFN	RGZ	48	250	180.0	16.4	7.3	7.3	1.5	12.0	16.0	Q2
BQ500410ARGZT	VQFN	RGZ	48	250	180.0	16.4	7.3	7.3	1.1	12.0	16.0	Q2

TAPE AND REEL BOX DIMENSIONS

*All dimensions are nominal

Device	Package Type	Package Drawing	Pins	SPQ	Length (mm)	Width (mm)	Height (mm)
BQ500410ARGZR	VQFN	RGZ	48	2500	367.0	367.0	38.0
BQ500410ARGZR	VQFN	RGZ	48	2500	367.0	367.0	38.0
BQ500410ARGZT	VQFN	RGZ	48	250	210.0	185.0	35.0
BQ500410ARGZT	VQFN	RGZ	48	250	210.0	185.0	35.0

GENERIC PACKAGE VIEW

RGZ 48

VQFN - 1 mm max height

7 x 7, 0.5 mm pitch

PLASTIC QUADFLAT PACK- NO LEAD

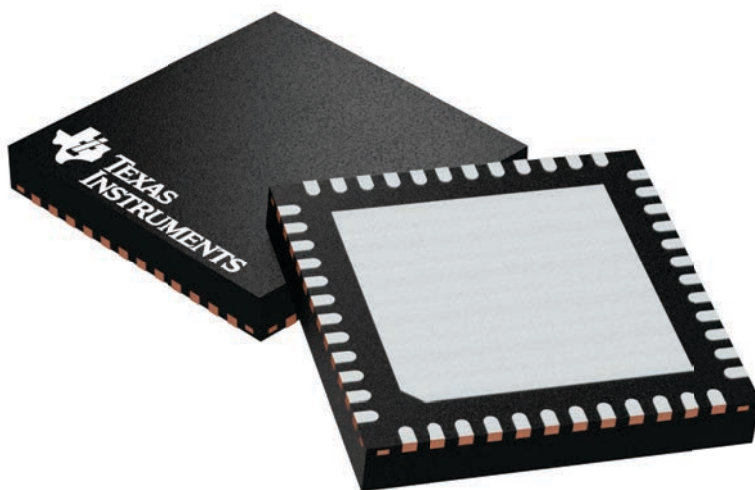

Images above are just a representation of the package family, actual package may vary.
Refer to the product data sheet for package details.

4224671/A

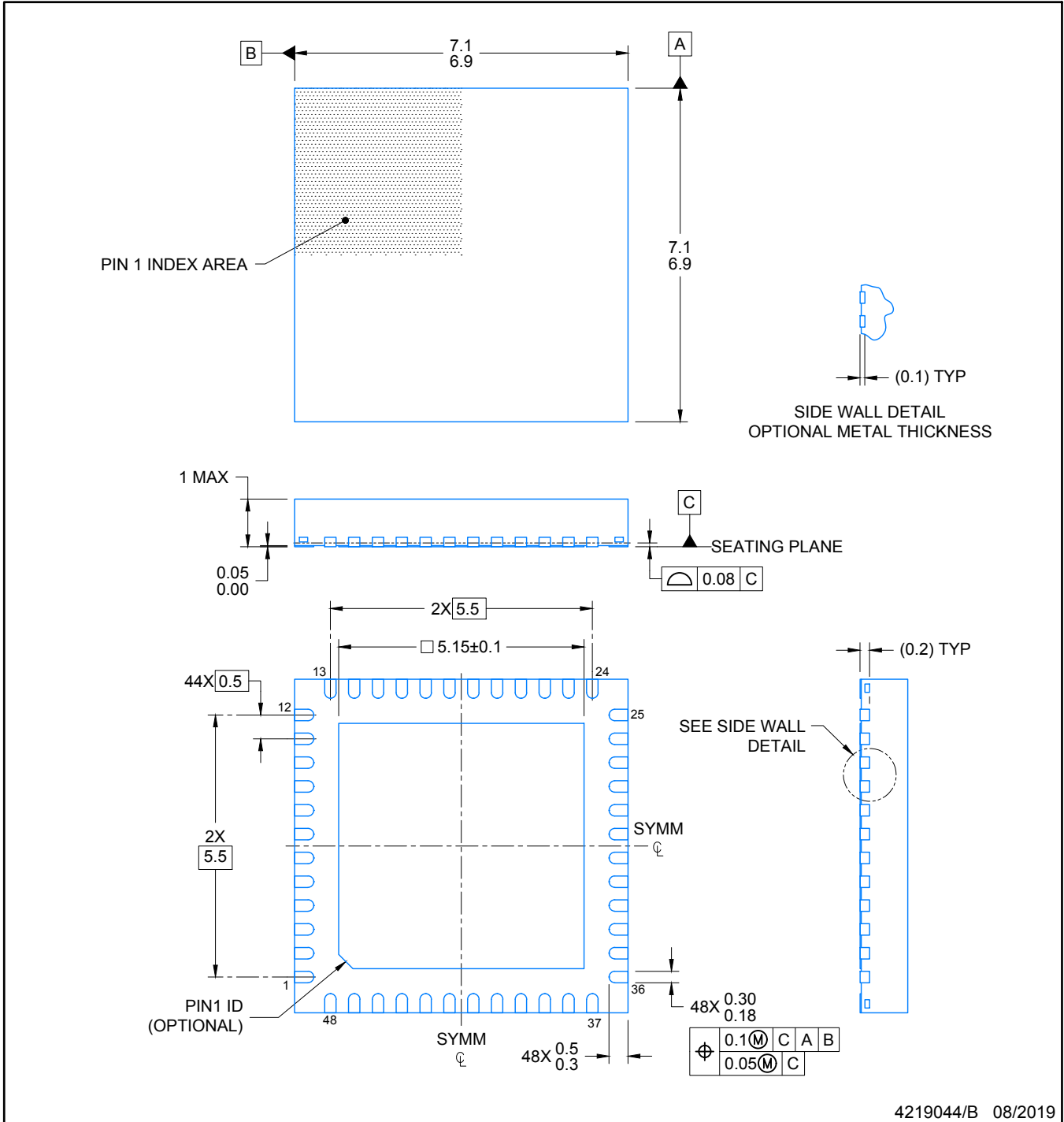

4219044/B 08/2019

NOTES:

1. All linear dimensions are in millimeters. Any dimensions in parenthesis are for reference only. Dimensioning and tolerancing per ASME Y14.5M.
2. This drawing is subject to change without notice.
3. The package thermal pad must be soldered to the printed circuit board for optimal thermal and mechanical performance.

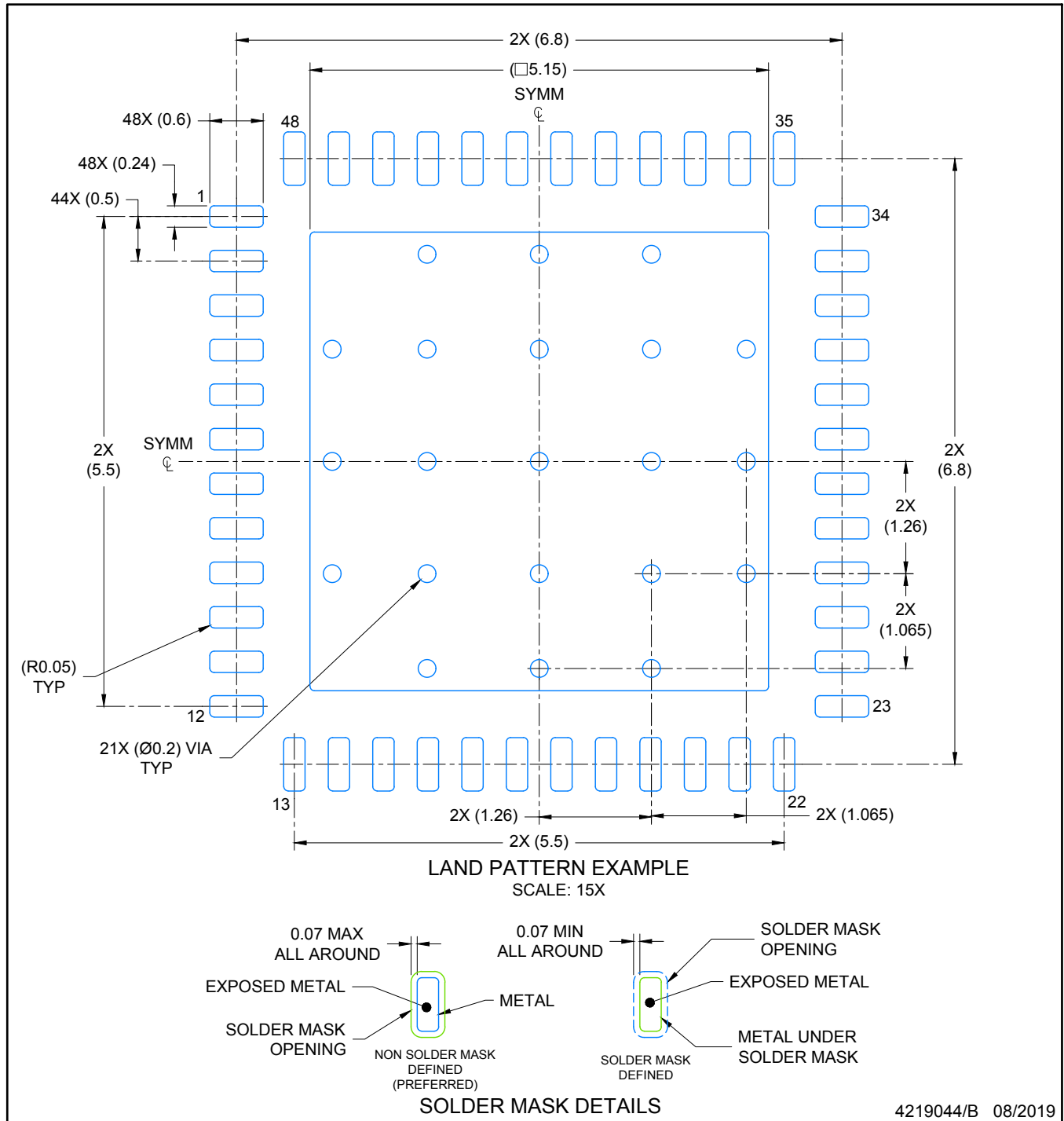

NOTES: (continued)

4. This package is designed to be soldered to a thermal pad on the board. For more information, see Texas Instruments literature number SLUA271 (www.ti.com/lit/slua271).
5. Vias are optional depending on application, refer to device data sheet. If any vias are implemented, refer to their locations shown on this view. It is recommended that vias under paste be filled, plugged or tented.

EXAMPLE STENCIL DESIGN

RGZ0048A

VQFN - 1 mm max height

PLASTIC QUADFLAT PACK- NO LEAD

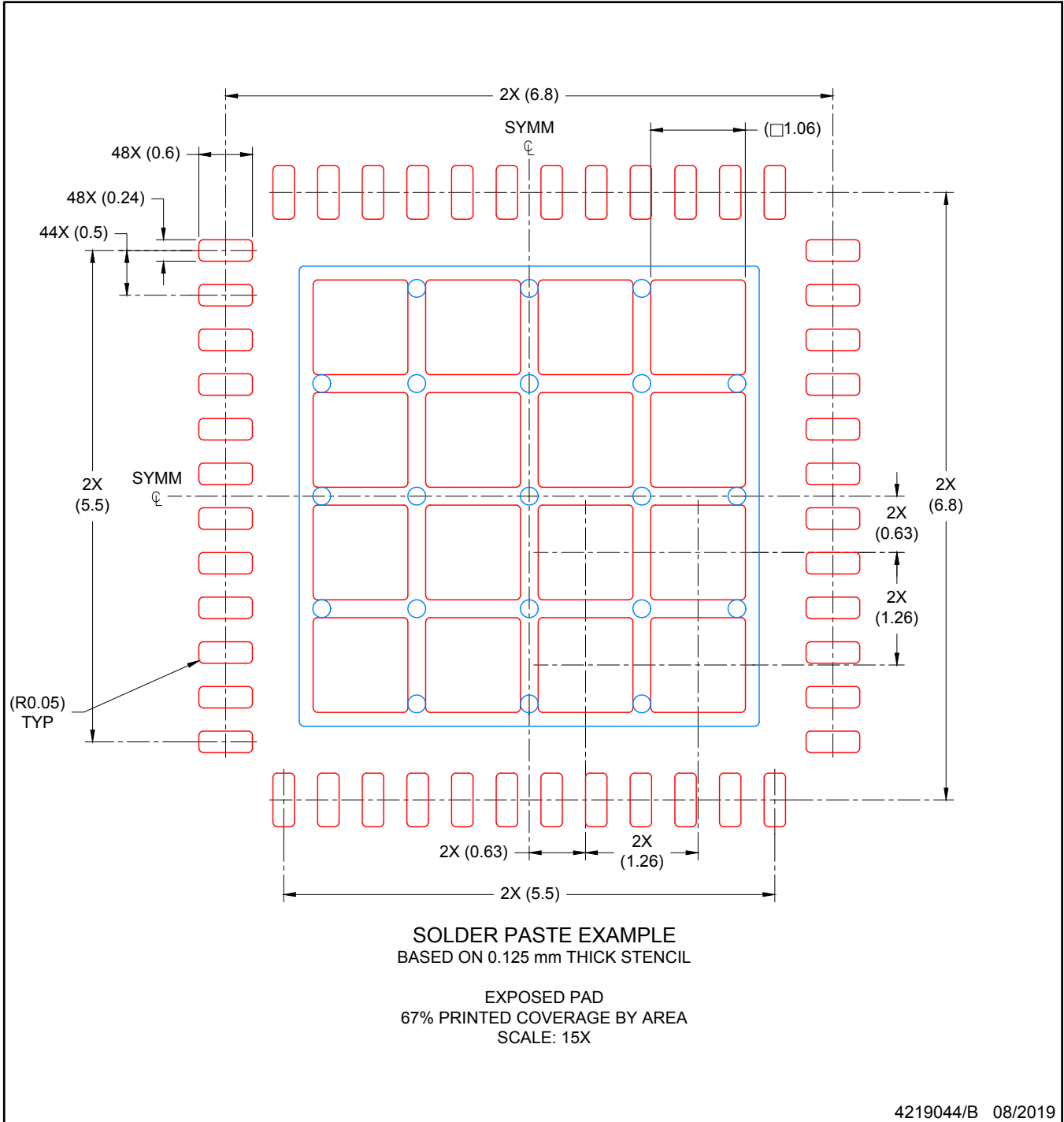

NOTES: (continued)

6. Laser cutting apertures with trapezoidal walls and rounded corners may offer better paste release. IPC-7525 may have alternate design recommendations.

IMPORTANT NOTICE AND DISCLAIMER

TI PROVIDES TECHNICAL AND RELIABILITY DATA (INCLUDING DATASHEETS), DESIGN RESOURCES (INCLUDING REFERENCE DESIGNS), APPLICATION OR OTHER DESIGN ADVICE, WEB TOOLS, SAFETY INFORMATION, AND OTHER RESOURCES "AS IS" AND WITH ALL FAULTS, AND DISCLAIMS ALL WARRANTIES, EXPRESS AND IMPLIED, INCLUDING WITHOUT LIMITATION ANY IMPLIED WARRANTIES OF MERCHANTABILITY, FITNESS FOR A PARTICULAR PURPOSE OR NON-INFRINGEMENT OF THIRD PARTY INTELLECTUAL PROPERTY RIGHTS.

These resources are intended for skilled developers designing with TI products. You are solely responsible for (1) selecting the appropriate TI products for your application, (2) designing, validating and testing your application, and (3) ensuring your application meets applicable standards, and any other safety, security, or other requirements. These resources are subject to change without notice. TI grants you permission to use these resources only for development of an application that uses the TI products described in the resource. Other reproduction and display of these resources is prohibited. No license is granted to any other TI intellectual property right or to any third party intellectual property right. TI disclaims responsibility for, and you will fully indemnify TI and its representatives against, any claims, damages, costs, losses, and liabilities arising out of your use of these resources.

TI's products are provided subject to TI's Terms of Sale (www.ti.com/legal/termsofsale.html) or other applicable terms available either on ti.com or provided in conjunction with such TI products. TI's provision of these resources does not expand or otherwise alter TI's applicable warranties or warranty disclaimers for TI products.

Mailing Address: Texas Instruments, Post Office Box 655303, Dallas, Texas 75265
Copyright © 2019, Texas Instruments Incorporated

Looking for pricing, stock, or lifecycle information?

Click below to explore more details on WIN SOURCE:

 [View BQ500410ARGZT on WIN SOURCE](#)

 [Texas Instruments](#) Information

Optimize Your Supply Chain with WIN SOURCE Solutions

-  Global Sourcing Solution
-  Obsolete Management
-  Cost Control Management
-  Shortage Management
-  Alternative Solution
-  Excess Inventory Management