

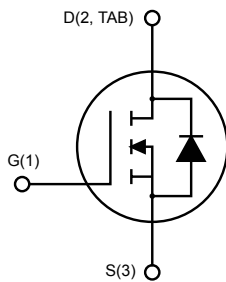

**THE DATASHEET OF
STB32N65M5**

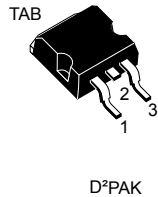

N-channel 650 V, 95 mΩ typ., 24 A MDmesh™ M5 Power MOSFET in D²PAK package



Features

Order codes	V _{DS} at T _{jmax} .	R _{DS(on)} max.	I _D
STB32N65M5	710 V	119 mΩ	24 A

- Extremely low R_{DS(on)}
- Low gate charge and input capacitance
- Excellent switching performance
- 100% avalanche tested

Applications

- Switching applications

Description

This device is an N-channel Power MOSFET based on the MDmesh™ M5 innovative vertical process technology combined with the well-known PowerMESH™ horizontal layout. The resulting product offers extremely low on-resistance, making it particularly suitable for applications requiring high power and superior efficiency.



Product status link

[STB32N65M5](#)

Product summary

Order code	STB32N65M5
Marking	32N65M5
Package	D ² PAK
Packing	Tape and reel

1 Electrical ratings

Table 1. Absolute maximum ratings

Symbol	Parameter	Value	Unit
V_{GS}	Gate-source voltage	± 25	V
I_D	Drain current (continuous) at $T_C = 25\text{ }^\circ\text{C}$	24	A
I_D	Drain current (continuous) at $T_C = 100\text{ }^\circ\text{C}$	15	A
$I_{DM}^{(1)}$	Drain current (pulsed)	96	A
P_{TOT}	Total power dissipation at $T_C = 25\text{ }^\circ\text{C}$	150	W
$dv/dt^{(2)}$	Peak diode recovery voltage slope	15	V/ns
T_j	Operating junction temperature range	-55 to 150	$^\circ\text{C}$
T_{stg}	Storage temperature range		

1. Pulse width limited by safe operating area.

2. $I_{SD} \leq 24\text{ A}$, $di/dt \leq 400\text{ A}/\mu\text{s}$, $V_{DS(peak)} \leq V_{(BR)DSS}$.

Table 2. Thermal data

Symbol	Parameter	Value	Unit
$R_{thj-case}$	Thermal resistance junction-case	0.83	$^\circ\text{C}/\text{W}$
$R_{thj-pcb}^{(1)}$	Thermal resistance junction-pcb	30	$^\circ\text{C}/\text{W}$

1. When mounted on FR-4 board of 1 inch², 2oz Cu.

Table 3. Avalanche characteristics

Symbol	Parameter	Value	Unit
I_{AR}	Avalanche current, repetitive or not-repetitive (pulse width limited by T_j Max)	8	A
E_{AS}	Single pulse avalanche energy (starting $T_j = 25\text{ }^\circ\text{C}$, $I_D = I_{AR}$, $V_{DD} = 50\text{ V}$)	650	mJ

2 Electrical characteristics

($T_{CASE} = 25\text{ °C}$ unless otherwise specified)

Table 4. On/off states

Symbol	Parameter	Test conditions	Min.	Typ.	Max.	Unit
$V_{(BR)DSS}$	Drain-source breakdown voltage	$I_D = 1\text{ mA}$, $V_{GS} = 0\text{ V}$	650			V
I_{DSS}	Zero gate voltage drain current	$V_{DS} = 650\text{ V}$, $V_{GS} = 0\text{ V}$,			1	μA
		$V_{DS} = 650\text{ V}$, $V_{GS} = 0\text{ V}$, $T_C = 125\text{ °C}$ ⁽¹⁾			100	μA
I_{GSS}	Gate body leakage current	$V_{DS} = 0\text{ V}$, $V_{GS} = \pm 25\text{ V}$			± 100	nA
$V_{GS(th)}$	Gate threshold voltage	$V_{DS} = V_{GS}$, $I_D = 250\text{ }\mu\text{A}$	3	4	5	V
$R_{DS(on)}$	Static drain-source on resistance	$V_{GS} = 10\text{ V}$, $I_D = 12\text{ A}$		95	119	m Ω

1. Defined by design, not subject to production test.

Table 5. Dynamic

Symbol	Parameter	Test conditions	Min.	Typ.	Max.	Unit
C_{iss}	Input capacitance	$V_{DS} = 100\text{ V}$, $f = 1\text{ MHz}$, $V_{GS} = 0\text{ V}$	-	3320	-	μF
C_{oss}	Output capacitance			75		
C_{riss}	Reverse transfer capacitance			5		
$C_{o(tr)}$ ⁽¹⁾	Equivalent capacitance time related	$V_{GS} = 0\text{ V}$, $V_{DS} = 0\text{ to }520\text{ V}$	-	210	-	μF
$C_{o(er)}$ ⁽²⁾	Equivalent capacitance energy related			70		
R_g	Gate input resistance	$f = 1\text{ MHz}$, $I_D = 0\text{ A}$	-	2	-	Ω
Q_g	Total gate charge	$V_{DD} = 520\text{ V}$, $I_D = 12\text{ A}$, $V_{GS} = 0\text{ to }10\text{ V}$ (see Figure 15. Test circuit for gate charge behavior)	-	72	-	nC
Q_{gs}	Gate-source charge			17		
Q_{gd}	Gate-drain charge			29		

1. $C_{o(tr)}$ time related is defined as a constant equivalent capacitance giving the same charging time as C_{oss} when V_{DS} increases from 0 to 80% V_{DSS} .

2. $C_{o(er)}$ energy related is defined as a constant equivalent capacitance giving the same stored energy as C_{oss} when V_{DS} increases from 0 to 80% V_{DSS} .

Table 6. Switching times

Symbol	Parameter	Test conditions	Min.	Typ.	Max.	Unit
$t_{d(off)}$	Turn-off delay time	$V_{DD} = 400\text{ V}$, $I_D = 15\text{ A}$, $R_G = 4.7\text{ }\Omega$, $V_{GS} = 10\text{ V}$ (see Figure 16. Test circuit for inductive load switching and diode recovery times and Figure 19. Switching time waveform)	-	53	-	ns
t_r	Rise time			12		
t_c	Cross time			29		
t_f	Fall time			16		

Table 7. Source drain diode

Symbol	Parameter	Test conditions	Min.	Typ.	Max.	Unit	
I_{SD}	Source-drain current		-		24	A	
$I_{SDM}^{(1)}$	Source-drain current (pulsed)				96		
$V_{SD}^{(2)}$	Forward on voltage	$I_{SD} = 24\text{ A}$, $V_{GS} = 0\text{ V}$	-		1.5	V	
t_{rr}	Reverse recovery time	$I_{SD} = 24\text{ A}$, $di/dt = 100\text{ A}/\mu\text{s}$ $V_{DD} = 60\text{ V}$ (see Figure 16. Test circuit for inductive load switching and diode recovery times)	-	375		ns	
Q_{rr}	Reverse recovery charge			6			μC
I_{RRM}	Reverse recovery current			33			
t_{rr}	Reverse recovery time	$I_{SD} = 24\text{ A}$, $di/dt = 100\text{ A}/\mu\text{s}$ $V_{DD} = 60\text{ V}$, $T_j = 150\text{ °C}$ (see Figure 16. Test circuit for inductive load switching and diode recovery times)	-	440		ns	
Q_{rr}	Reverse recovery charge			8			μC
I_{RRM}	Reverse recovery current			36			

1. Pulse width limited by safe operating area.
2. Pulsed: pulse duration = 300 μs, duty cycle 1.5%.

2.1 Electrical characteristics curves

Figure 1. Safe operating area

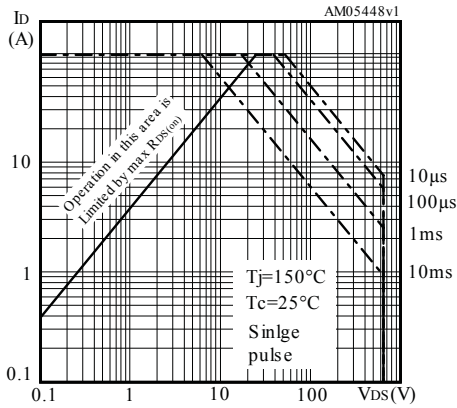

Figure 2. Thermal impedance

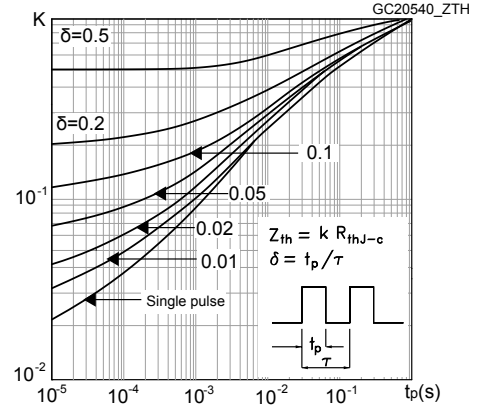

Figure 3. Output characteristics

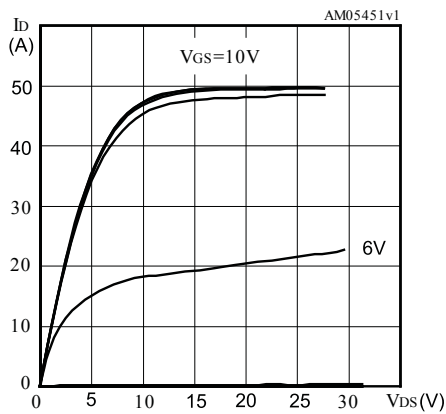

Figure 4. Transfer characteristics

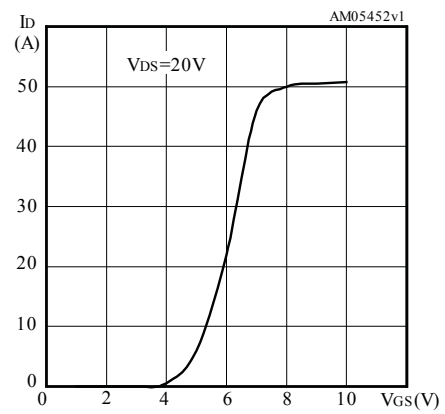

Figure 5. Gate charge vs gate-source voltage

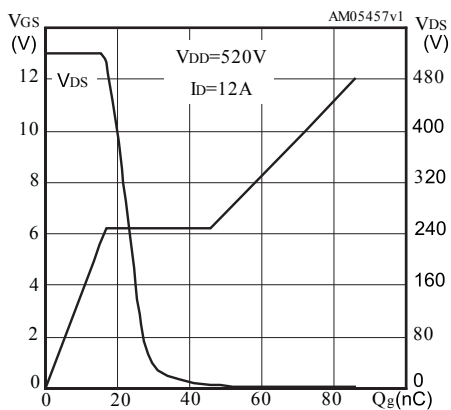

Figure 6. Static drain-source on resistance

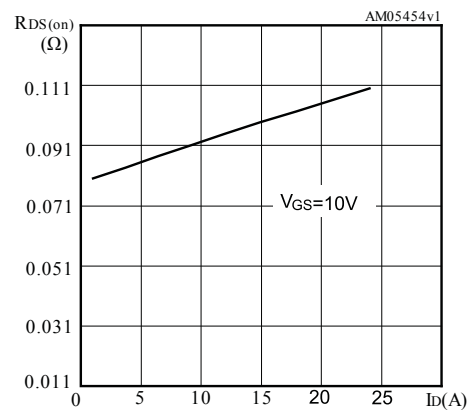

Figure 7. Capacitance variations

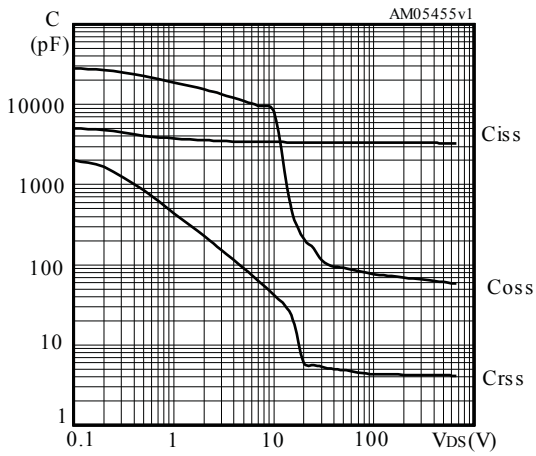

Figure 8. Output capacitance stored energy

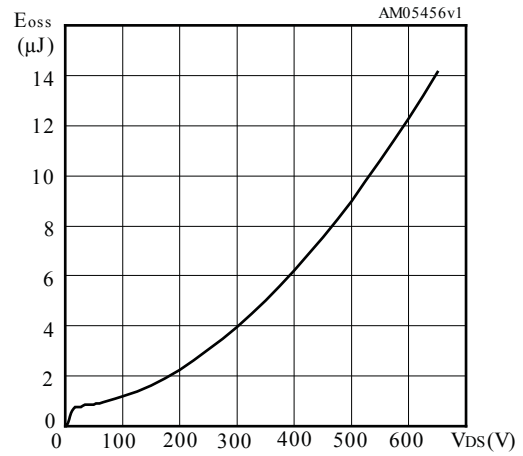

Figure 9. Normalized gate threshold voltage vs temperature

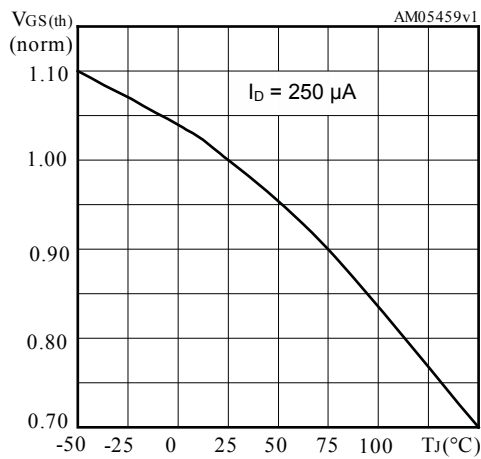

Figure 10. Normalized on resistance vs temperature

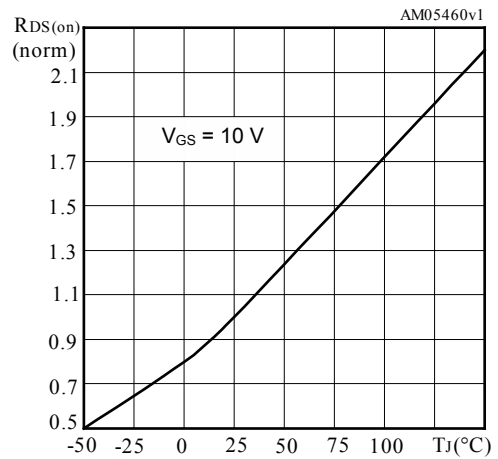

Figure 11. Source-drain diode forward characteristics

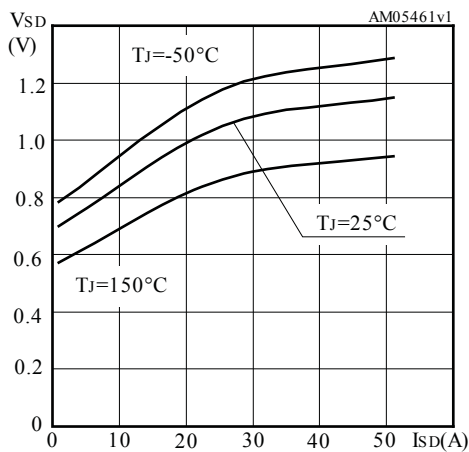

Figure 12. Normalized V_{(BR)DSS} vs temperature

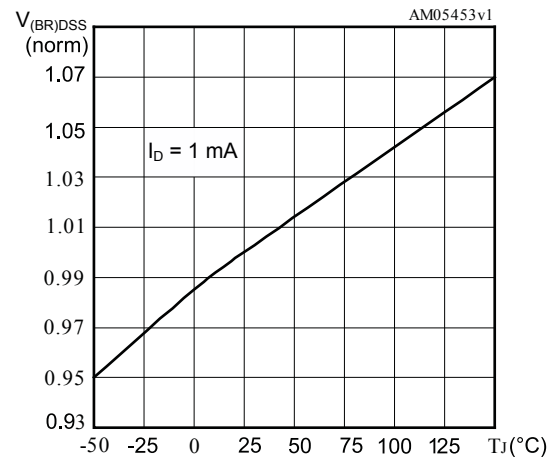
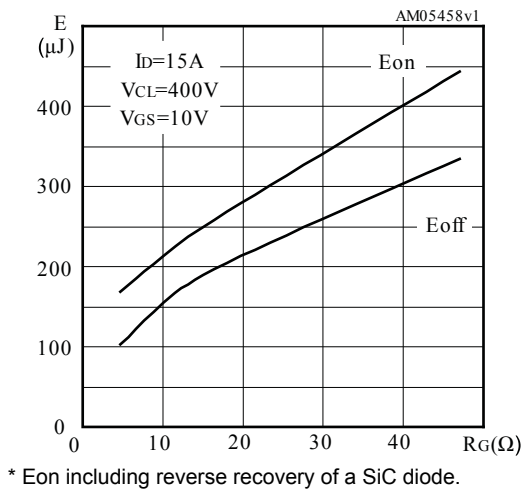
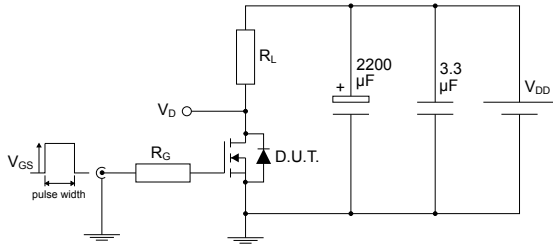

Figure 13. Switching energy vs gate resistance



3 Test circuits

Figure 14. Test circuit for resistive load switching times

AM01488v1

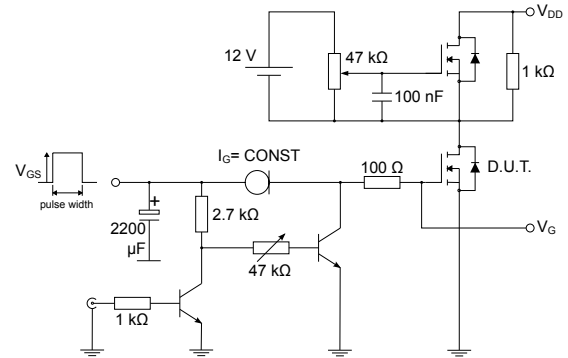
Figure 15. Test circuit for gate charge behavior

AM01469v1

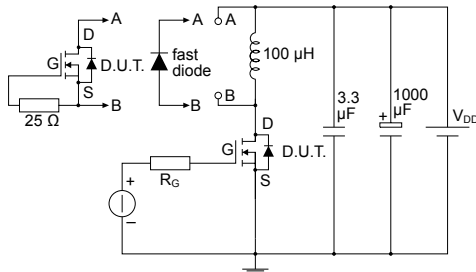
Figure 16. Test circuit for inductive load switching and diode recovery times

AM01470v1

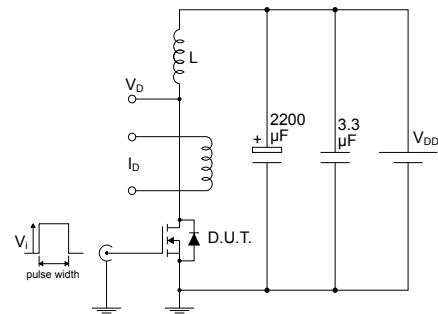
Figure 17. Unclamped inductive load test circuit

AM01471v1

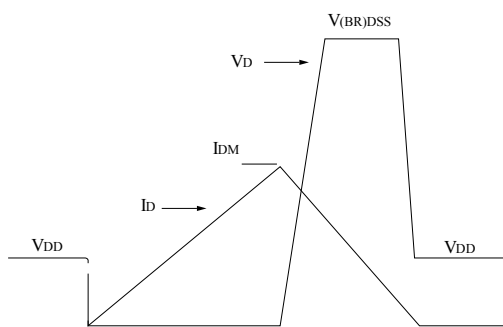
Figure 18. Unclamped inductive waveform

AM01472v1

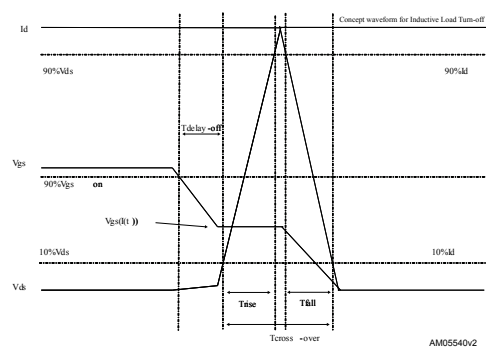
Figure 19. Switching time waveform

AM05540v2

4 Package information

In order to meet environmental requirements, ST offers these devices in different grades of **ECOPACK®** packages, depending on their level of environmental compliance. ECOPACK® specifications, grade definitions and product status are available at: www.st.com. ECOPACK® is an ST trademark.

4.1 D²PAK (TO-263) type A package information

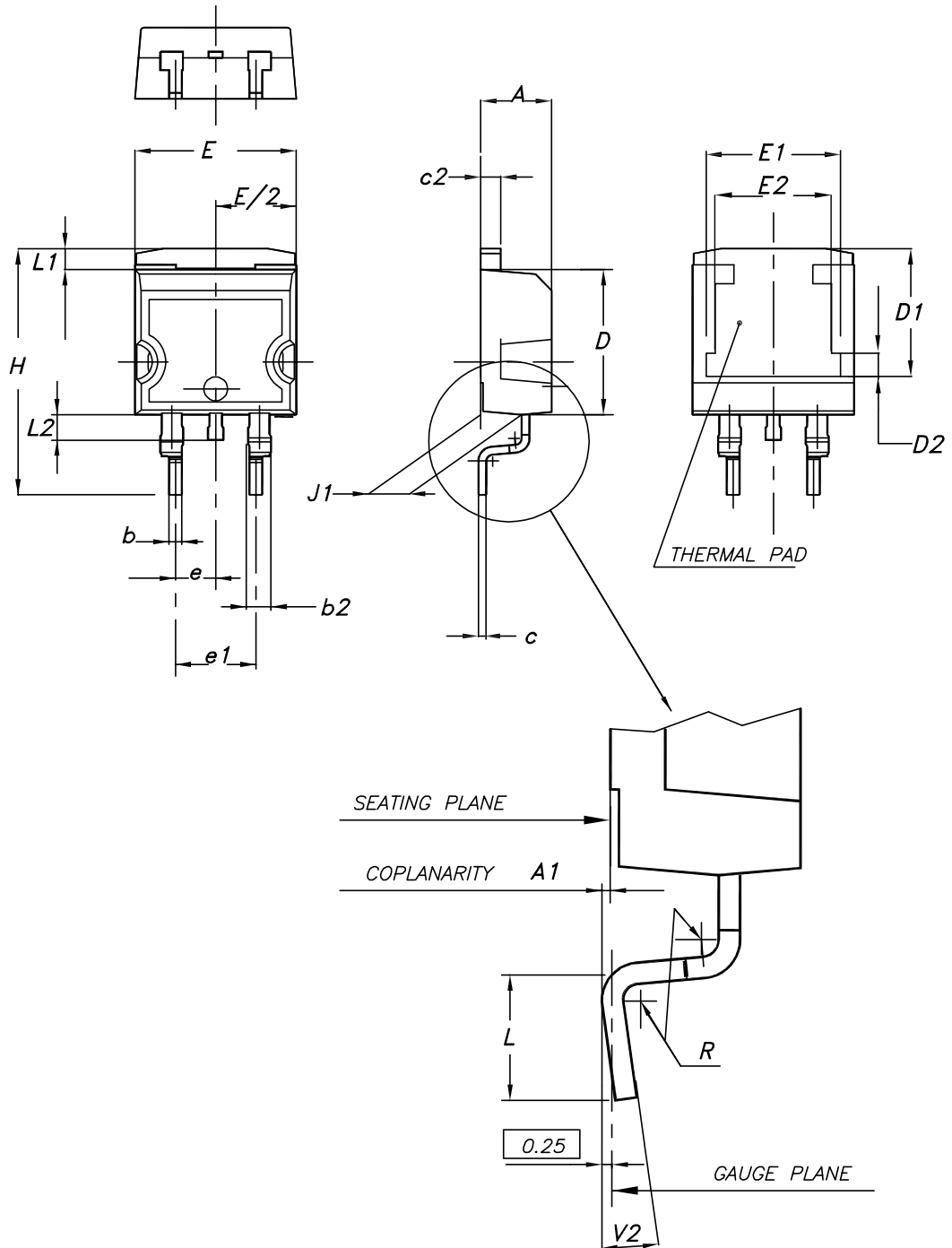
 Figure 20. D²PAK (TO-263) type A package outline

0079457_25

Table 8. D²PAK (TO-263) type A package mechanical data

Dim.	mm		
	Min.	Typ.	Max.
A	4.40		4.60
A1	0.03		0.23
b	0.70		0.93
b2	1.14		1.70
c	0.45		0.60
c2	1.23		1.36
D	8.95		9.35
D1	7.50	7.75	8.00
D2	1.10	1.30	1.50
E	10.00		10.40
E1	8.30	8.50	8.70
E2	6.85	7.05	7.25
e		2.54	
e1	4.88		5.28
H	15.00		15.85
J1	2.49		2.69
L	2.29		2.79
L1	1.27		1.40
L2	1.30		1.75
R		0.40	
V2	0°		8°

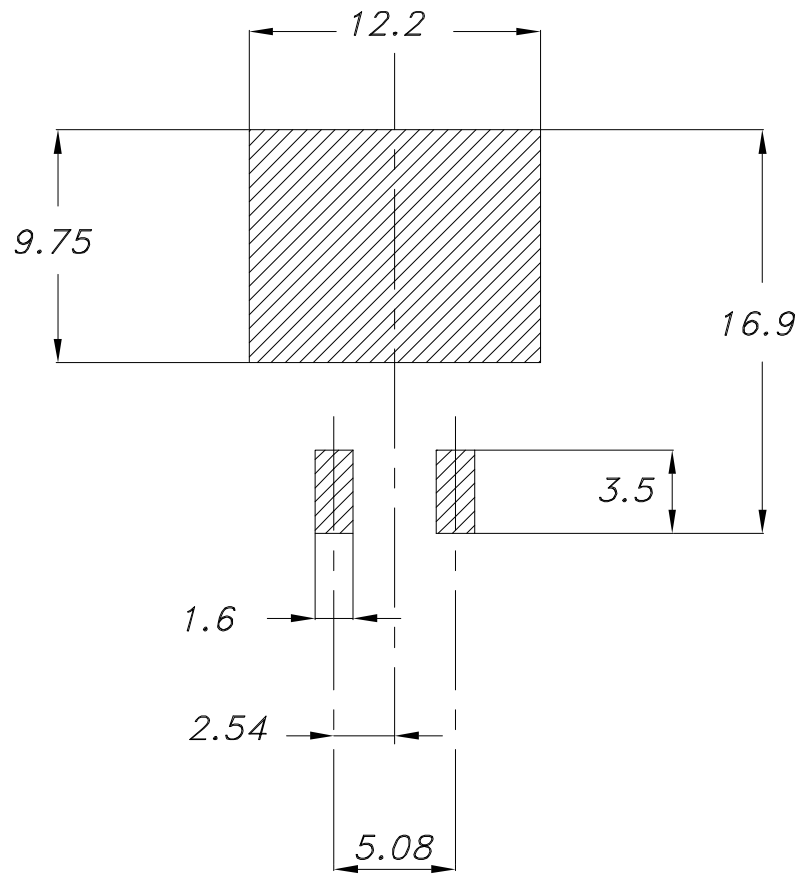
Figure 21. D²PAK (TO-263) recommended footprint (dimensions are in mm)

Footprint

4.2 D²PAK packing information

Figure 22. D²PAK tape outline

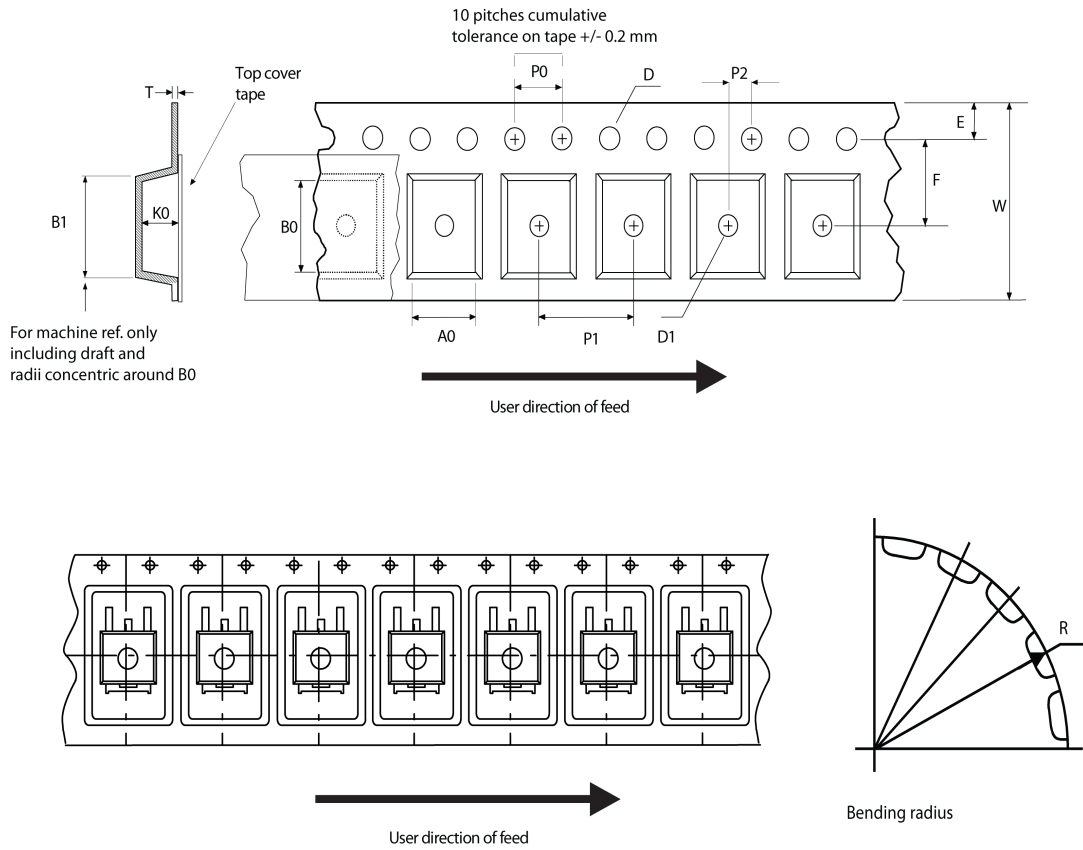

AM08852v1

Figure 23. D²PAK reel outline

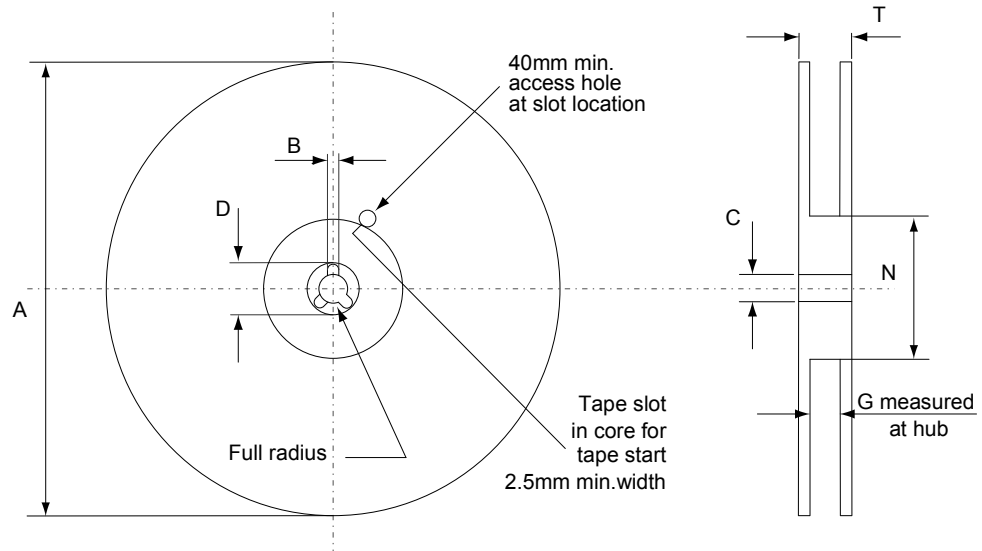

AM06038v1

Table 9. D²PAK tape and reel mechanical data

Tape			Reel			
Dim.	mm		Dim.	mm		
	Min.	Max.		Min.	Max.	
A0	10.5	10.7	A		330	
B0	15.7	15.9	B	1.5		
D	1.5	1.6	C	12.8	13.2	
D1	1.59	1.61	D	20.2		
E	1.65	1.85	G	24.4	26.4	
F	11.4	11.6	N	100		
K0	4.8	5.0	T		30.4	
P0	3.9	4.1	Base quantity Bulk quantity			
P1	11.9	12.1				1000
P2	1.9	2.1				1000
R	50					
T	0.25	0.35				
W	23.7	24.3				

Revision history

Table 10. Document revision history

Date	Version	Changes
16-Jan-2009	1	First release
01-Sep-2009	2	Document status promoted from preliminary data to datasheet.
30-Sep-2009	3	Corrected V_{GS} value on Table 2: Absolute maximum ratings
06-Oct-2011	4	<p>$C_{o(er)}$ and $C_{o(tr)}$ values changed in <i>Table 5: Dynamic</i></p> <p><i>Table 6: Switching times</i> parameters updates</p> <p><i>Figure 24: Switching time waveform</i> has been corrected</p> <p>Minor text changes</p> <p><i>Section 4: Package mechanical data</i> has been modified. Added:</p> <ul style="list-style-type: none"> – <i>Table 8: D²PAK (TO-263) mechanical data, Figure 25: D²PAK (TO-263) drawing and Figure 26: D²PAK footprint,</i> – <i>Table 9: TO-220FP mechanical data, and Figure 27: TO-220FP drawing;</i> – <i>Table 10: I²PAK (TO-262) mechanical data, and Figure 28: I²PAK (TO-262) drawing;</i> – <i>Table 11: TO-220 type A mechanical data, and Figure 29: TO-220 type A drawing;</i> – <i>Table 12: TO-247 mechanical data, and Figure 30: TO-247 drawing;</i> <p><i>Section 5: Packaging mechanical data</i> has been modified. Added:</p> <ul style="list-style-type: none"> – <i>Table 13: D²PAK (TO-263) tape and reel mechanical data, Figure 31: Tape and Figure 32: Reel;</i>
02-Nov-2018	5	<p>The part numbers STF32N65M5, STI32N65M5, STP32N65M5, STW32N65M5 have been moved to a separate datasheet.</p> <p>Content reworked to improve readability, no technical changes.</p>

Contents

1	Electrical ratings	2
2	Electrical characteristics	3
2.1	Electrical characteristics curves	5
3	Test circuits	8
4	Package information	9
4.1	D ² PAK (TO-263) type A package information	9
4.2	D ² PAK packing information	12
	Revision history	15

IMPORTANT NOTICE – PLEASE READ CAREFULLY

STMicroelectronics NV and its subsidiaries (“ST”) reserve the right to make changes, corrections, enhancements, modifications, and improvements to ST products and/or to this document at any time without notice. Purchasers should obtain the latest relevant information on ST products before placing orders. ST products are sold pursuant to ST’s terms and conditions of sale in place at the time of order acknowledgement.

Purchasers are solely responsible for the choice, selection, and use of ST products and ST assumes no liability for application assistance or the design of Purchasers’ products.

No license, express or implied, to any intellectual property right is granted by ST herein.

Resale of ST products with provisions different from the information set forth herein shall void any warranty granted by ST for such product.



ST and the ST logo are trademarks of ST. All other product or service names are the property of their respective owners.

Information in this document supersedes and replaces information previously supplied in any prior versions of this document.



© 2018 STMicroelectronics – All rights reserved

Looking for pricing, stock, or lifecycle information?

Click below to explore more details on WIN SOURCE:

-  [View STB32N65M5 on WIN SOURCE](#)
-  [STMicroelectronics Information](#)

Optimize Your Supply Chain with WIN SOURCE Solutions

-  Global Sourcing Solution
-  Obsolete Management
-  Cost Control Management
-  Shortage Management
-  Alternative Solution
-  Excess Inventory Management