

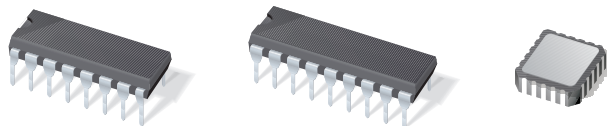

THE DATASHEET OF UC2544N





Power Supply Supervisory Circuit

FEATURES

- Includes Over-Voltage, Under-Voltage, and Current Sensing Circuits
- Internal 1% Accurate Reference
- Programmable Time Delays
- SCR “Crowbar” Drive of 300 mA
- Remote Activation Capability
- Optional Over-Voltage Latch
- Uncommitted Comparator Inputs for Low Voltage Sensing (UC1544 Series Only)

DESCRIPTION

The monolithic integrated circuits contain all the functions necessary to monitor and control the output of a sophisticated power supply system. Over-voltage (O.V.) sensing with provision to trigger an external SCR “crowbar” shutdown; an undervoltage (U.V.) circuit which can be used to monitor either the output or to sample the input line voltage; and a third op amp/comparator usable for current sensing (C.L.) are all included in this device, together with an independent, accurate reference generator.

Both over- and under-voltage sensing circuits can be externally programmed for minimum time duration of fault before triggering. All functions contain open collector outputs which can be used independently or wire-or’ed together, and although the SCR trigger is directly connected only to the over-voltage sensing circuit, it may be optionally activated by any of the other outputs, or from an external signal. The O.V. circuit also includes an optional latch and external reset capability.

The UC1544/2544/3544 devices have the added versatility of completely uncommitted inputs to the voltage sensing comparators so that levels less than 2.5 V may be monitored by dividing down the internal reference voltage. The current sense circuit may be used with external compensation as a linear amplifier or as a highgain comparator. Although nominally set for zero input offset, a fixed threshold may be added with an external resistor. Instead of current limiting, this circuit may also be used as an additional voltage monitor.

The reference generator circuit is internally trimmed to eliminate the need for external potentiometers and the entire circuit may be powered directly from either the output being monitored or from a separate bias voltage.

BLOCK DIAGRAM

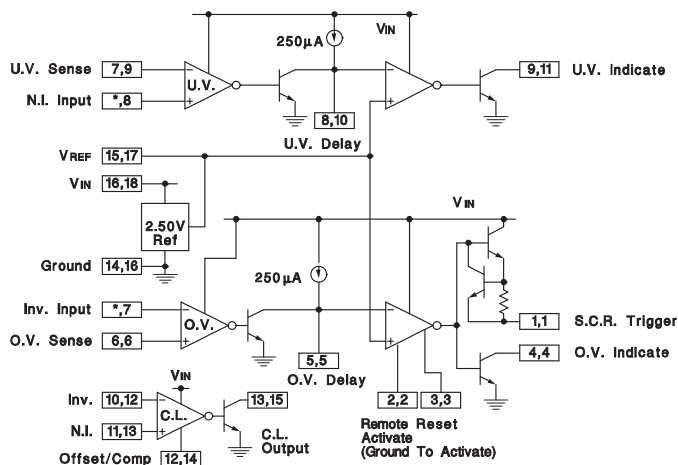

NOTE:

For each terminal, first number refers to 1543 series, second to 1544 series.
*On 1543 series, this function is internally connected to VREF.



Please be aware that an important notice concerning availability, standard warranty, and use in critical applications of Texas Instruments semiconductor products and disclaimers thereto appears at the end of this data sheet.

Connection Diagrams

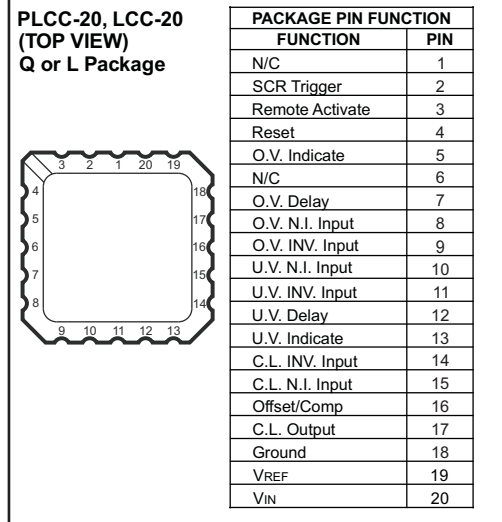
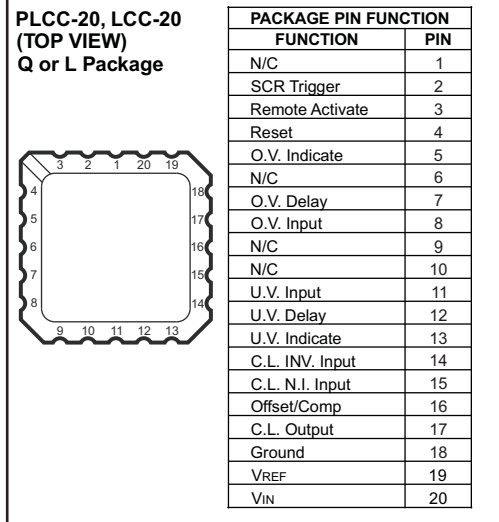
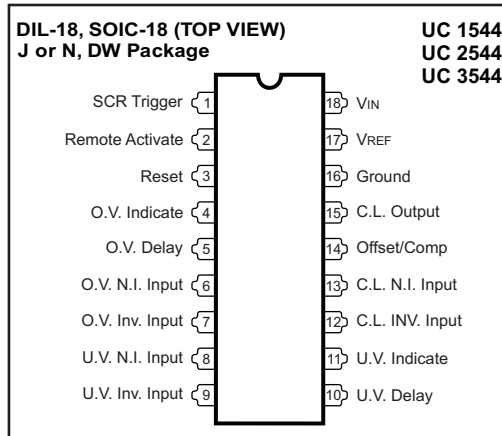
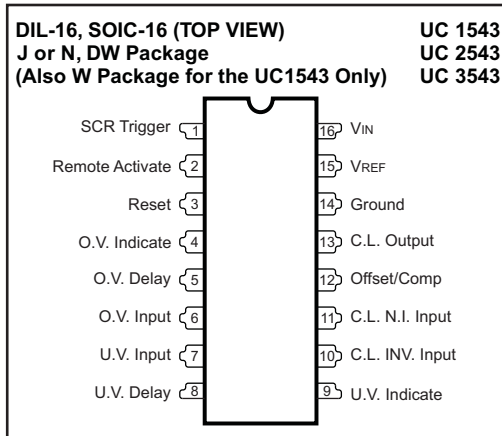

ABSOLUTE MAXIMUM RATINGS⁽¹⁾

over operating free-air temperature range (unless otherwise noted)

		VALUE	UNIT
V_{IN}	Input supply voltage	40	V
	Sense inputs, voltage range	0 to V_{IN}	
	SCR trigger current ⁽²⁾	-600	mA
	Indicator output voltage	40	V
	Indicator output sink current	50	mA
	Power dissipation (package limitation)	1000	mW
T_J	Operating temperature range	UC1543, UC1544	°C
		UC2543, UC2544	
		UC3543, UC3544	
T_{stg}	Storage temperature range	-65 to 150	

(1) Currents are positive-into, negative-out of the specified terminal.

(2) At higher input voltages, a dissipation limiting resistor, R_G , is required.

ELECTRICAL CHARACTERISTICS

Unless otherwise stated, these specifications apply for $T_A = -55^\circ\text{C}$ to 125°C for the UC1543 and UC1544; -25°C to 85°C for the UC2543 and UC2544; and 0°C to 70°C for the UC3543 and UC3544. Electrical tests are performed with $V_{IN} = 10\text{ V}$ and 2-k Ω pull-up resistors on all indicator outputs. All electrical specifications for the UC1544, UC2544, and UC3544 devices are tested with the inverting over-voltage input and the non-inverting under-voltage input externally connected to the 2.5 V reference. $T_A = T_J$.

PARAMETER		TEST CONDITIONS	UC1543/UC1544/UC2543/ UC2544			UC3543/UC3544			UNIT
			MIN	TYP	MAX	MIN	TYP	MAX	
V_{IN}	Input voltage range	$T_J = 25^\circ\text{C}$ to T_{MAX}	4.5		40	4.5		40	V
		T_{MIN} to T_{MAX}	4.7		40	4.7		40	
I_{CC}	Supply current	$V_{IN} = 40\text{ V}$, output open, $T_J = 25^\circ\text{C}$		7	10		7	10	mA
		$T_{MIN} \leq T_J \leq T_{MAX}$			15			15	
Reference Section									
V_{OUT}	Output voltage	$T_J = 25^\circ\text{C}$	2.48	2.5	2.52	2.45	2.50	2.55	V
		Over temperature range	2.45		2.55	2.40		2.60	
	Line regulation	$V_{IN} = 5$ to 30 V		1	5		1	5	mV
	Load regulation	$I_{REF} = 0$ to 10 mA		1	10		1	10	
	Short circuit current	$V_{REF} = 0$	-10	-20	-40	-12	-20	-40	mA
	Temperature stability			50			50		ppm/ $^\circ\text{C}$
SCR Trigger Section									
	Peak output current	$V_{IN} = 5\text{ V}$, $R_G = 0$, $V_O = 0$	-100	-300	-600	-100	-300	-600	mA
	Peak output voltage	$V_{IN} = 15\text{ V}$, $I_O = -100\text{ mA}$	12	13		12	13		V
	Output OFF voltage	$V_{IN} = 40\text{ V}$		0	0.1		0	0.1	
	Remote activate current	R/A Pin = GND		-0.4	-0.8		-0.4	-0.8	mA
	Remote activate voltage	R/A Pin Open		2	6		2	6	V
	Reset current	Reset = GND, R/A = GND		-0.4	-0.8		-0.4	-0.8	mA
	Reset voltage	Reset open, R/A = GND		2	6		2	6	V
	Output current rise time	$R_L = 50$, $T_J = 25^\circ\text{C}$, $C_D = 0$		400			400		mA/ μs
	Prop. delay from R/A	$R_L = 50$, $T_J = 25^\circ\text{C}$, $C_D = 0$		300			300		ns
	Prop. delay from O/V input	$R_L = 50$, $T_J = 25^\circ\text{C}$, $C_D = 0$		500			500		
Comparator Section									
	Input threshold (Input voltage rising on O.V. and falling on U.V.)	$T_J = 25^\circ\text{C}$	2.45	2.50	2.55	2.40	2.50	2.60	V
		Over temperature range	2.40		2.60	2.35		2.65	
	Input hysteresis			25			25		mV
	Input bias current	Sense input = 0 V		-0.3	-1.0		-0.3	-1.0	μA
	Delay saturation			0.2	0.5		0.2	0.5	V
	Delay high level			6	7		6	7	
	Delay charging current	$V_O = 0$	-200	-250	-300	-200	-250	-300	μA
	Indicate saturation	$I_L = 10\text{ mA}$		0.2	0.5		0.2	0.5	V
	Indicate leakage	$V_{IND} = 40\text{ V}$		0.01	1.0		0.01	1.0	μA
	Propagation delay	Input over drive = 200 mV, $T_J = 25^\circ\text{C}$, $C_D = 0$		400			400		ns
		Input over drive = 200 mV, $T_J = 25^\circ\text{C}$, $C_D = 1\ \mu\text{F}$		10			10		ms

ELECTRICAL CHARACTERISTICS (continued)

Unless otherwise stated, these specifications apply for $T_A = -55^{\circ}\text{C}$ to 125°C for the UC1543 and UC1544; -25°C to 85°C for the UC2543 and UC2544; and 0°C to 70°C for the UC3543 and UC3544. Electrical tests are performed with $V_{IN} = 10\text{ V}$ and 2-k Ω pull-up resistors on all indicator outputs. All electrical specifications for the UC1544, UC2544, and UC3544 devices are tested with the inverting over-voltage input and the non-inverting under-voltage input externally connected to the 2.5 V reference. $T_A = T_J$.

Current Limit Section								
Input voltage range		0		VIN -3V	0		VIN -3V	V
Input Bias Current	Offset pin open, $V_{CM} = 0$		-0.3	-1.0		-0.3	-1.0	μA
Input offset voltage	Offset pin open, $V_{CM} = 0$		0	10		0	10	mV
	10k from offset pin to GND	80	100	120	80	100	120	
CMRR	$0 \leq V_{CM} \leq 12\text{ V}$, $V_{IN} = 15\text{ V}$	60	70		60	70		dB
AVOL	Offset pin open, $V_{CM} = 0$ V_i , $R_L = 10\text{ k}\Omega$ to $15\text{ k}\Omega$, $V_{OUT} = 1$ to 6 V	72	80		72	80		
Output saturation	$I_L = 10\text{ mA}$		0.2	0.5		0.2	0.5	V
Output leakage	$V_{IND} = 40\text{ V}$		0.01	1.0		0.01	1.0	μA
Small signal bandwidth	$A_V = 0\text{ dB}$, $T_J = 25^{\circ}\text{C}$		5			5		MHz
Propagation delay	$V_{OVERDRIVE} = 100\text{ mV}$, $T_J = 25^{\circ}\text{C}$		200			200		ns

TYPICAL CHARACTERISTICS

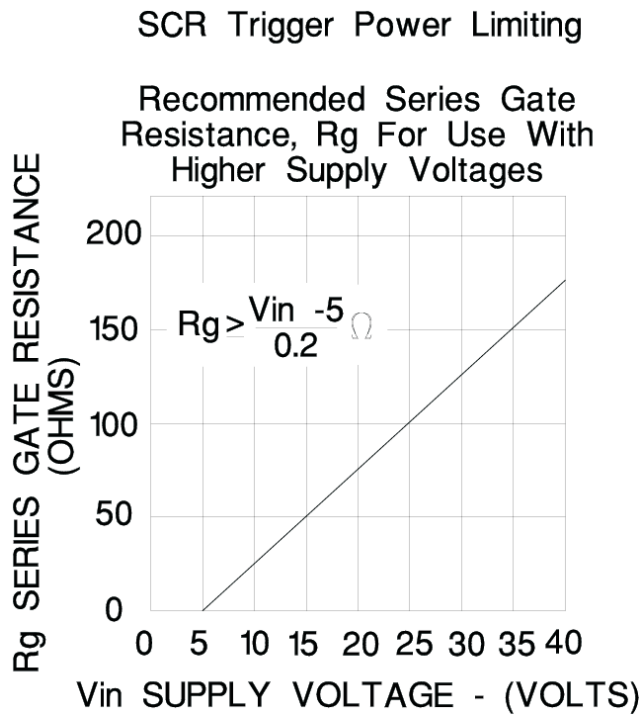

Figure 1.

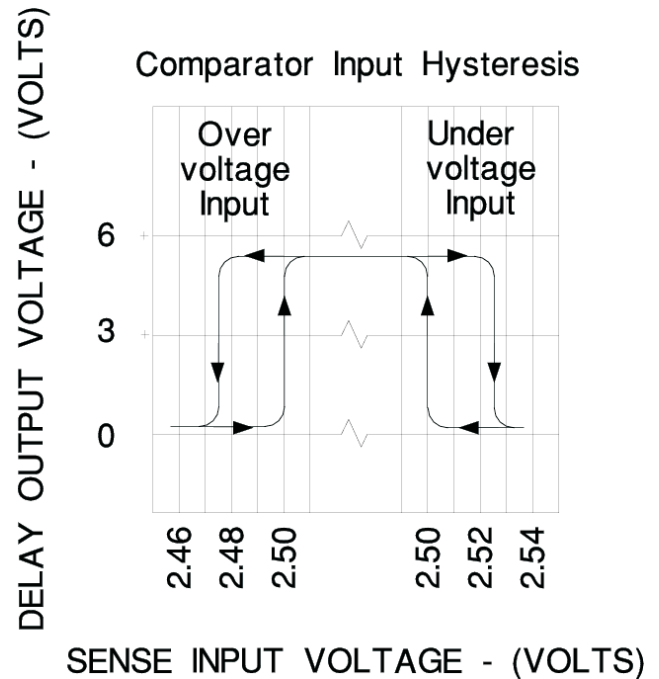

Figure 2.

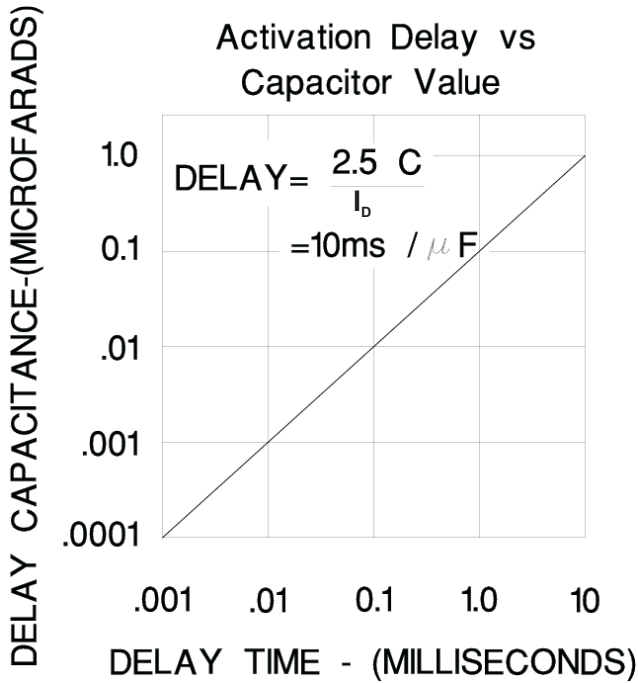

Figure 3.

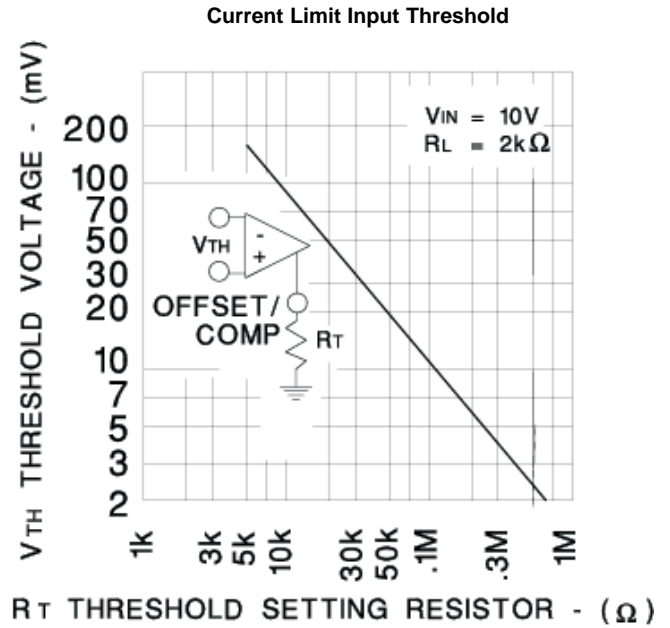

Figure 4.

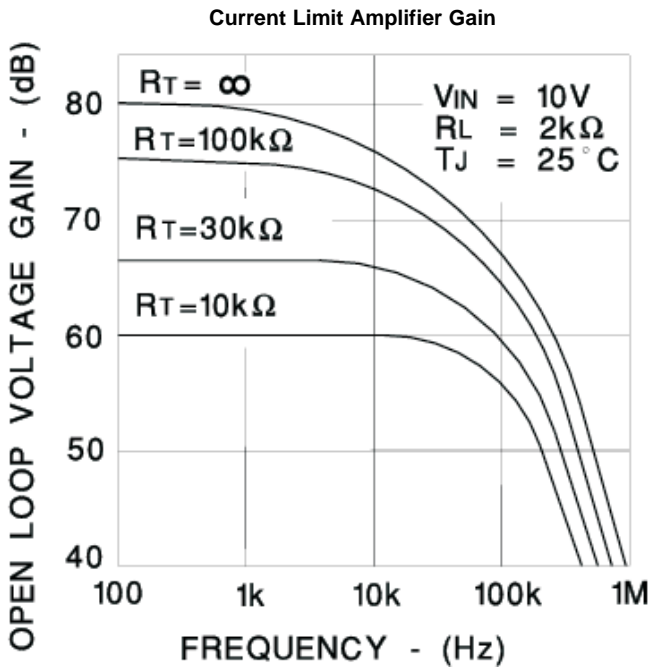

Figure 5.

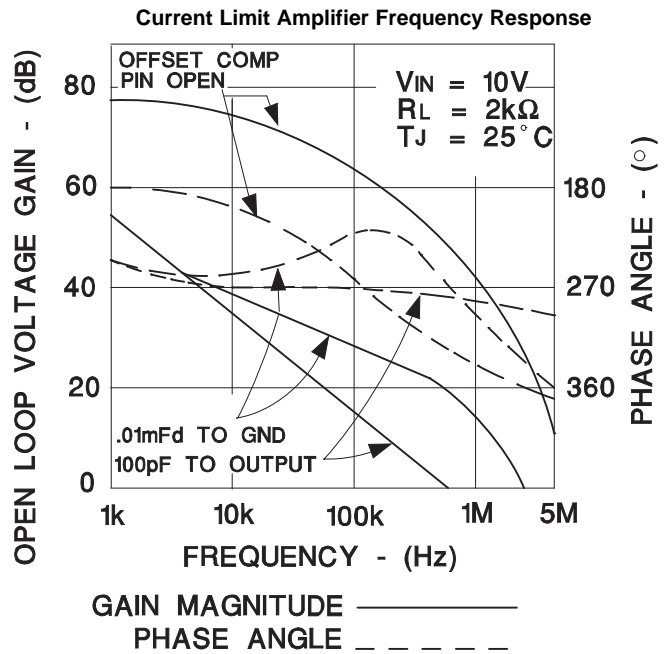

Figure 6.

APPLICATION INFORMATION

The values for the external components are determined as follows:

$$V_{TH} = \frac{1000}{R1}$$

Current limit input threshold,

C_S is determined by the current loop dynamics

$$I_P \cong \frac{V_{TH}}{R_{SC}} + \frac{V_O}{R_{SC}} \left(\frac{R2}{R2 + R3} \right)$$

Peak current to load,

$$I_{SC} = \frac{V_{TH}}{R_{SC}}$$

Short circuit current,

$$V_{O(low)} = \frac{2.5(R4 + R5 + R6)}{R5 + R6}$$

Low output voltage limit,

$$V_{O(high)} = \frac{2.5(R4 + R5 + R6)}{R6}$$

High output voltage limit,

Voltage sensing delay, $t_D = 10,000C_d$

$$R_G > \frac{V_{IN} - 5}{0.2}$$

SCR trigger power limiting resistor,

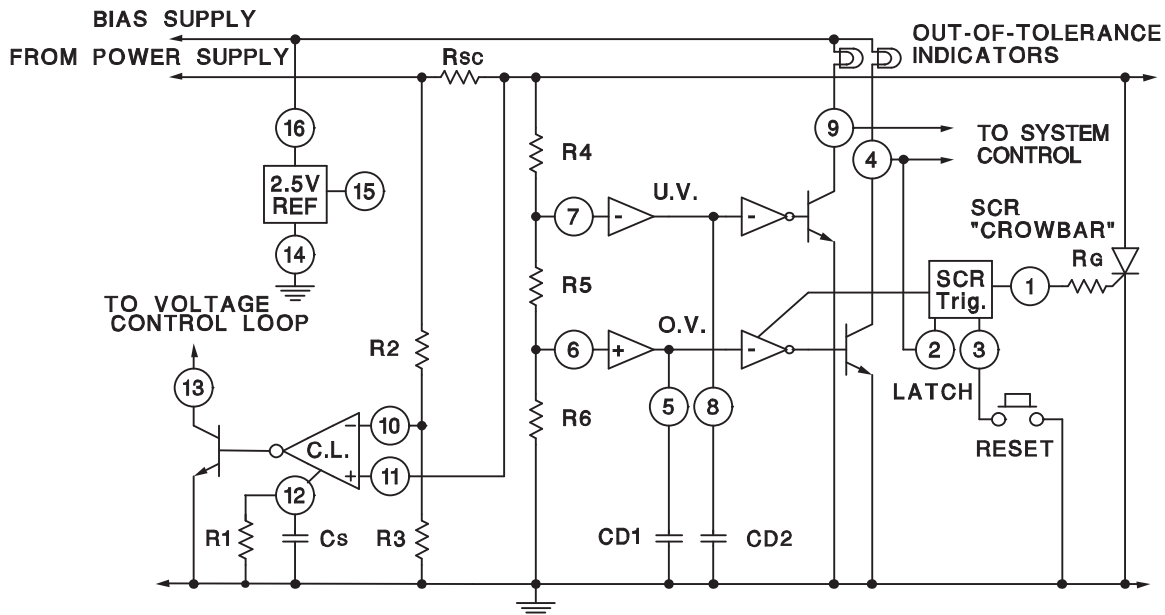

Figure 7. Typical Application

APPLICATION INFORMATION (continued)

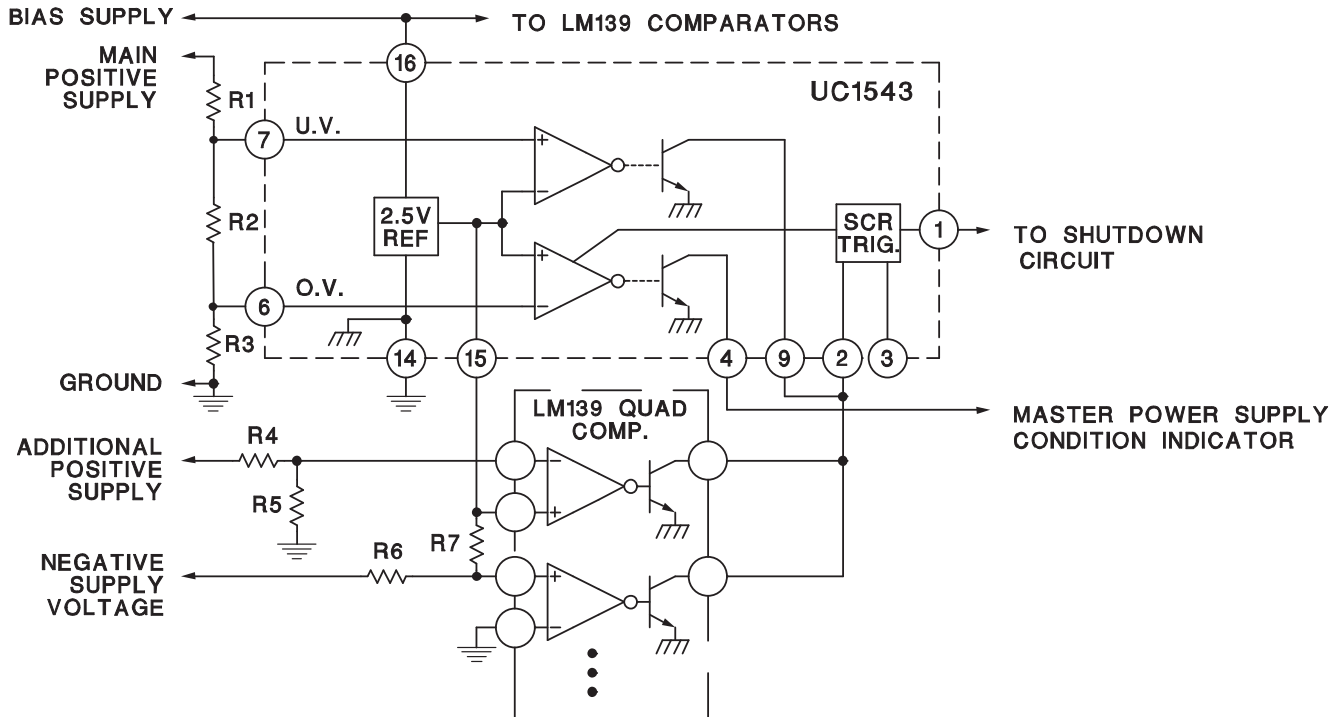

Figure 8. Sensing Multiple Supply Voltages

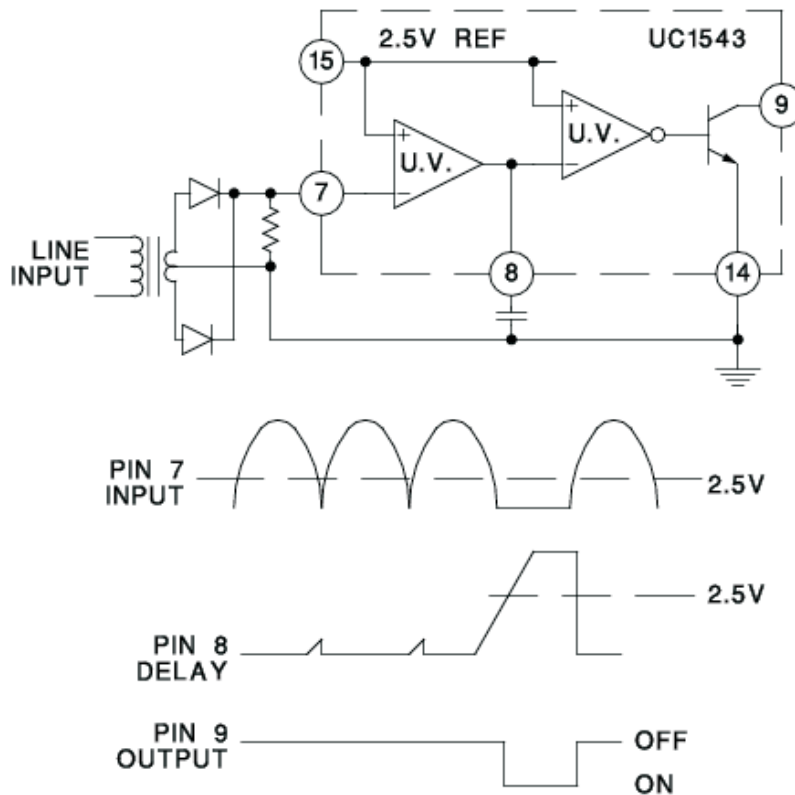

Figure 9. Input Line Monitor

APPLICATION INFORMATION (continued)

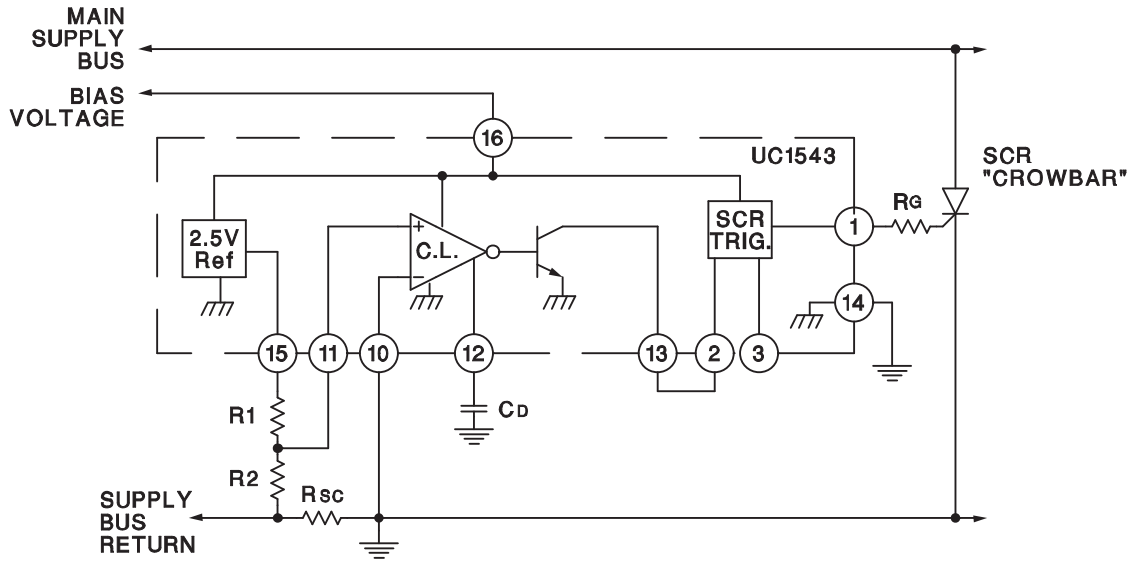

Figure 10. Overcurrent Shutdown

PACKAGING INFORMATION

Orderable Device	Status (1)	Package Type	Package Drawing	Pins	Package Qty	Eco Plan (2)	Lead/Ball Finish (6)	MSL Peak Temp (3)	Op Temp (°C)	Device Marking (4/5)	Samples
5962-8774001EA	ACTIVE	CDIP	J	16	1	TBD	A42	N / A for Pkg Type	-55 to 125	5962-8774001EA UC1543J/883B	Samples
5962-8774001FA	ACTIVE	CFP	W	16	25	TBD	A42	N / A for Pkg Type		5962-8774001FA UC1543W/883B	Samples
5962-8774002VA	OBSOLETE	CDIP	J	18		TBD	Call TI	Call TI	-55 to 125		
UC1543J	ACTIVE	CDIP	J	16	1	TBD	A42	N / A for Pkg Type	-55 to 125	UC1543J	Samples
UC1543J883B	ACTIVE	CDIP	J	16	1	TBD	A42	N / A for Pkg Type	-55 to 125	5962-8774001EA UC1543J/883B	Samples
UC1543L	ACTIVE	LCCC	FK	20	1	TBD	POST-PLATE	N / A for Pkg Type	-55 to 125	UC1543L	Samples
UC1543L883B	ACTIVE	LCCC	FK	20	1	TBD	POST-PLATE	N / A for Pkg Type	-55 to 125	UC1543L/ 883B	Samples
UC1543W883B	ACTIVE	CFP	W	16	25	TBD	A42	N / A for Pkg Type		5962-8774001FA UC1543W/883B	Samples
UC1544J	OBSOLETE	CDIP	J	18		TBD	Call TI	Call TI	-55 to 125		
UC1544J883B	OBSOLETE	CDIP	J	18		TBD	Call TI	Call TI	-55 to 125		
UC1544L	OBSOLETE	LCCC	FK	20		TBD	Call TI	Call TI	-55 to 125		
UC1544L883B	OBSOLETE	LCCC	FK	20		TBD	Call TI	Call TI	-55 to 125		
UC2543DW	NRND	SOIC	DW	16	40	Green (RoHS & no Sb/Br)	CU NIPDAU	Level-2-260C-1 YEAR	-40 to 85	UC2543DW	
UC2543DWG4	NRND	SOIC	DW	16	40	Green (RoHS & no Sb/Br)	CU NIPDAU	Level-2-260C-1 YEAR	-40 to 85	UC2543DW	
UC2543J	ACTIVE	CDIP	J	16	1	TBD	A42	N / A for Pkg Type	-25 to 85	UC2543J	Samples
UC2543N	LIFEBUY	PDIP	N	16	25	Green (RoHS & no Sb/Br)	CU NIPDAU	N / A for Pkg Type	-40 to 85	UC2543N	
UC2543NG4	LIFEBUY	PDIP	N	16	25	Green (RoHS & no Sb/Br)	CU NIPDAU	N / A for Pkg Type	-40 to 85	UC2543N	
UC2544-W	ACTIVE	WAFERSALE	YS	0		TBD	Call TI	Call TI			Samples
UC2544DW	NRND	SOIC	DW	18	40	Green (RoHS & no Sb/Br)	CU NIPDAU	Level-2-260C-1 YEAR	-40 to 85	UC2544DW	
UC2544J	OBSOLETE	CDIP	J	18		TBD	Call TI	Call TI	-40 to 85		

Orderable Device	Status (1)	Package Type	Package Drawing	Pins	Package Qty	Eco Plan (2)	Lead/Ball Finish (6)	MSL Peak Temp (3)	Op Temp (°C)	Device Marking (4/5)	Samples
UC2544N	LIFEBUY	PDIP	N	18	20	Green (RoHS & no Sb/Br)	CU NIPDAU	N / A for Pkg Type	-40 to 85	UC2544N	
UC3543J	ACTIVE	CDIP	J	16	1	TBD	A42	N / A for Pkg Type	0 to 70	UC3543J	Samples
UC3543N	LIFEBUY	PDIP	N	16	25	Green (RoHS & no Sb/Br)	CU NIPDAU	N / A for Pkg Type	0 to 70	UC3543N	
UC3543NG4	LIFEBUY	PDIP	N	16	25	Green (RoHS & no Sb/Br)	CU NIPDAU	N / A for Pkg Type	0 to 70	UC3543N	
UC3544J	OBSOLETE	CDIP	J	18		TBD	Call TI	Call TI	0 to 70		
UC3544N	LIFEBUY	PDIP	N	18	20	Green (RoHS & no Sb/Br)	CU NIPDAU	N / A for Pkg Type	0 to 70	UC3544N	
UC3544NG4	LIFEBUY	PDIP	N	18	20	Green (RoHS & no Sb/Br)	CU NIPDAU	N / A for Pkg Type	0 to 70	UC3544N	

(1) The marketing status values are defined as follows:

ACTIVE: Product device recommended for new designs.

LIFEBUY: TI has announced that the device will be discontinued, and a lifetime-buy period is in effect.

NRND: Not recommended for new designs. Device is in production to support existing customers, but TI does not recommend using this part in a new design.

PREVIEW: Device has been announced but is not in production. Samples may or may not be available.

OBSOLETE: TI has discontinued the production of the device.

(2) Eco Plan - The planned eco-friendly classification: Pb-Free (RoHS), Pb-Free (RoHS Exempt), or Green (RoHS & no Sb/Br) - please check <http://www.ti.com/productcontent> for the latest availability information and additional product content details.

TBD: The Pb-Free/Green conversion plan has not been defined.

Pb-Free (RoHS): TI's terms "Lead-Free" or "Pb-Free" mean semiconductor products that are compatible with the current RoHS requirements for all 6 substances, including the requirement that lead not exceed 0.1% by weight in homogeneous materials. Where designed to be soldered at high temperatures, TI Pb-Free products are suitable for use in specified lead-free processes.

Pb-Free (RoHS Exempt): This component has a RoHS exemption for either 1) lead-based flip-chip solder bumps used between the die and package, or 2) lead-based die adhesive used between the die and leadframe. The component is otherwise considered Pb-Free (RoHS compatible) as defined above.

Green (RoHS & no Sb/Br): TI defines "Green" to mean Pb-Free (RoHS compatible), and free of Bromine (Br) and Antimony (Sb) based flame retardants (Br or Sb do not exceed 0.1% by weight in homogeneous material)

(3) MSL, Peak Temp. - The Moisture Sensitivity Level rating according to the JEDEC industry standard classifications, and peak solder temperature.

(4) There may be additional marking, which relates to the logo, the lot trace code information, or the environmental category on the device.

(5) Multiple Device Markings will be inside parentheses. Only one Device Marking contained in parentheses and separated by a "~" will appear on a device. If a line is indented then it is a continuation of the previous line and the two combined represent the entire Device Marking for that device.

⁽⁶⁾ Lead/Ball Finish - Orderable Devices may have multiple material finish options. Finish options are separated by a vertical ruled line. Lead/Ball Finish values may wrap to two lines if the finish value exceeds the maximum column width.

Important Information and Disclaimer:The information provided on this page represents TI's knowledge and belief as of the date that it is provided. TI bases its knowledge and belief on information provided by third parties, and makes no representation or warranty as to the accuracy of such information. Efforts are underway to better integrate information from third parties. TI has taken and continues to take reasonable steps to provide representative and accurate information but may not have conducted destructive testing or chemical analysis on incoming materials and chemicals. TI and TI suppliers consider certain information to be proprietary, and thus CAS numbers and other limited information may not be available for release.

In no event shall TI's liability arising out of such information exceed the total purchase price of the TI part(s) at issue in this document sold by TI to Customer on an annual basis.

OTHER QUALIFIED VERSIONS OF UC1543, UC1544, UC2543, UC2543M, UC3543, UC3543M, UC3544 :

- Catalog: [UC3543](#), [UC3544](#), [UC2543](#), [UC3543M](#), [UC3543](#)

- Military: [UC2543M](#), [UC1543](#), [UC1543](#), [UC1544](#)

NOTE: Qualified Version Definitions:

- Catalog - TI's standard catalog product

- Military - QML certified for Military and Defense Applications

J (R-GDIP-T**)

14 LEADS SHOWN

CERAMIC DUAL IN-LINE PACKAGE



DIM \ PINS **	14	16	18	20
A	0.300 (7,62) BSC	0.300 (7,62) BSC	0.300 (7,62) BSC	0.300 (7,62) BSC
B MAX	0.785 (19,94)	.840 (21,34)	0.960 (24,38)	1.060 (26,92)
B MIN	—	—	—	—
C MAX	0.300 (7,62)	0.300 (7,62)	0.310 (7,87)	0.300 (7,62)
C MIN	0.245 (6,22)	0.245 (6,22)	0.220 (5,59)	0.245 (6,22)



4040083/F 03/03

- NOTES:
- All linear dimensions are in inches (millimeters).
 - This drawing is subject to change without notice.
 - This package is hermetically sealed with a ceramic lid using glass frit.
 - Index point is provided on cap for terminal identification only on press ceramic glass frit seal only.
 - Falls within MIL STD 1835 GDIP1-T14, GDIP1-T16, GDIP1-T18 and GDIP1-T20.

W (R-GDFP-F16)

CERAMIC DUAL FLATPACK



- NOTES:
- A. All linear dimensions are in inches (millimeters).
 - B. This drawing is subject to change without notice.
 - C. This package can be hermetically sealed with a ceramic lid using glass frit.
 - D. Index point is provided on cap for terminal identification only.
 - E. Falls within MIL STD 1835 GDFP2-F16

N (R-PDIP-T**)

PLASTIC DUAL-IN-LINE PACKAGE

16 PINS SHOWN



- NOTES:
- A. All linear dimensions are in inches (millimeters).
 - B. This drawing is subject to change without notice.
 - Falls within JEDEC MS-001, except 18 and 20 pin minimum body length (Dim A).
 - The 20 pin end lead shoulder width is a vendor option, either half or full width.

DW (R-PDSO-G18)

PLASTIC SMALL OUTLINE

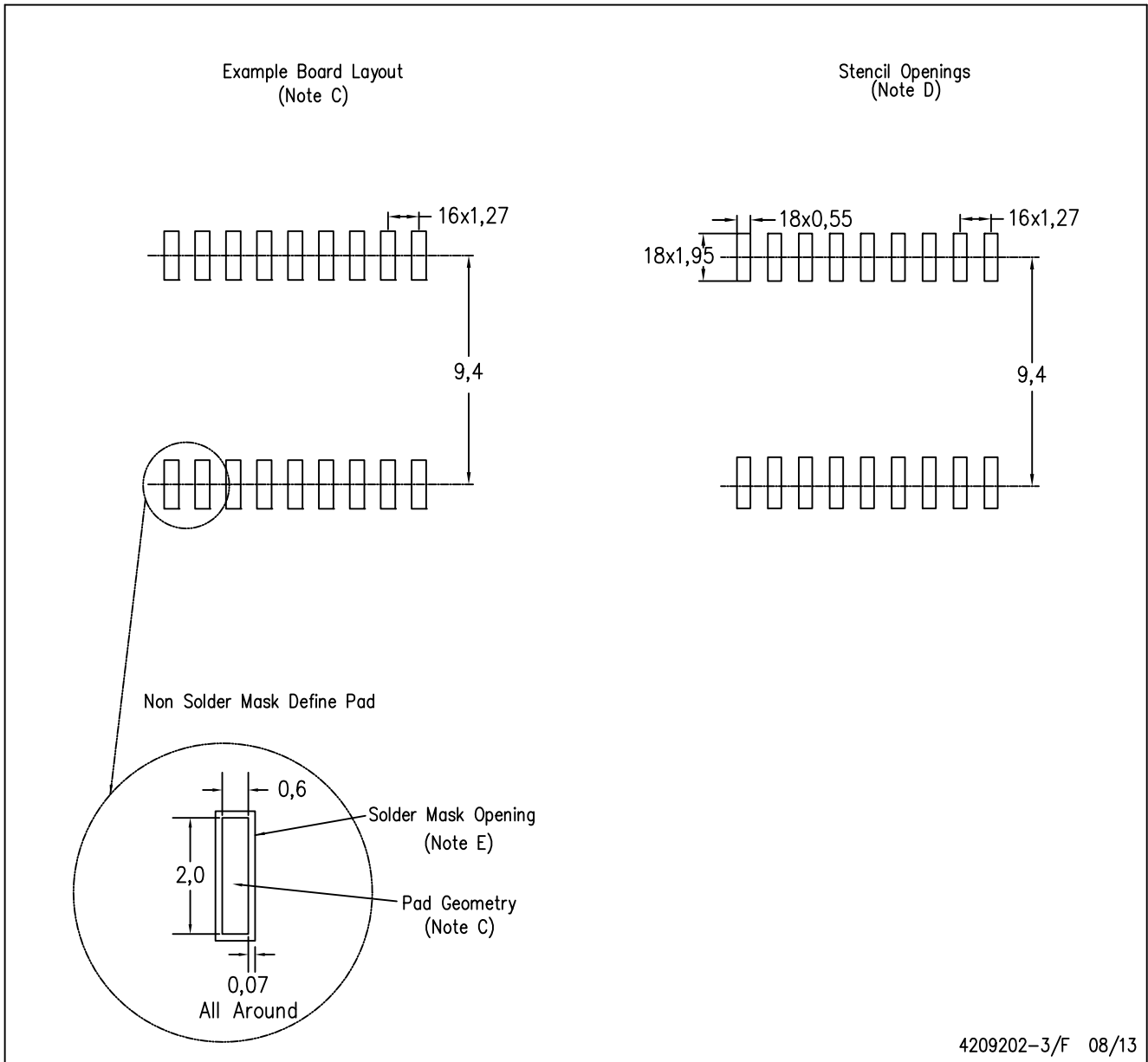

4209202-3/F 08/13

- NOTES:
- A. All linear dimensions are in millimeters.
 - B. This drawing is subject to change without notice.
 - C. Refer to IPC7351 for alternate board design.
 - D. Laser cutting apertures with trapezoidal walls and also rounding corners will offer better paste release. Customers should contact their board assembly site for stencil design recommendations. Refer to IPC-7525
 - E. Customers should contact their board fabrication site for solder mask tolerances between and around signal pads.

DW (R-PDSO-G16)

PLASTIC SMALL OUTLINE

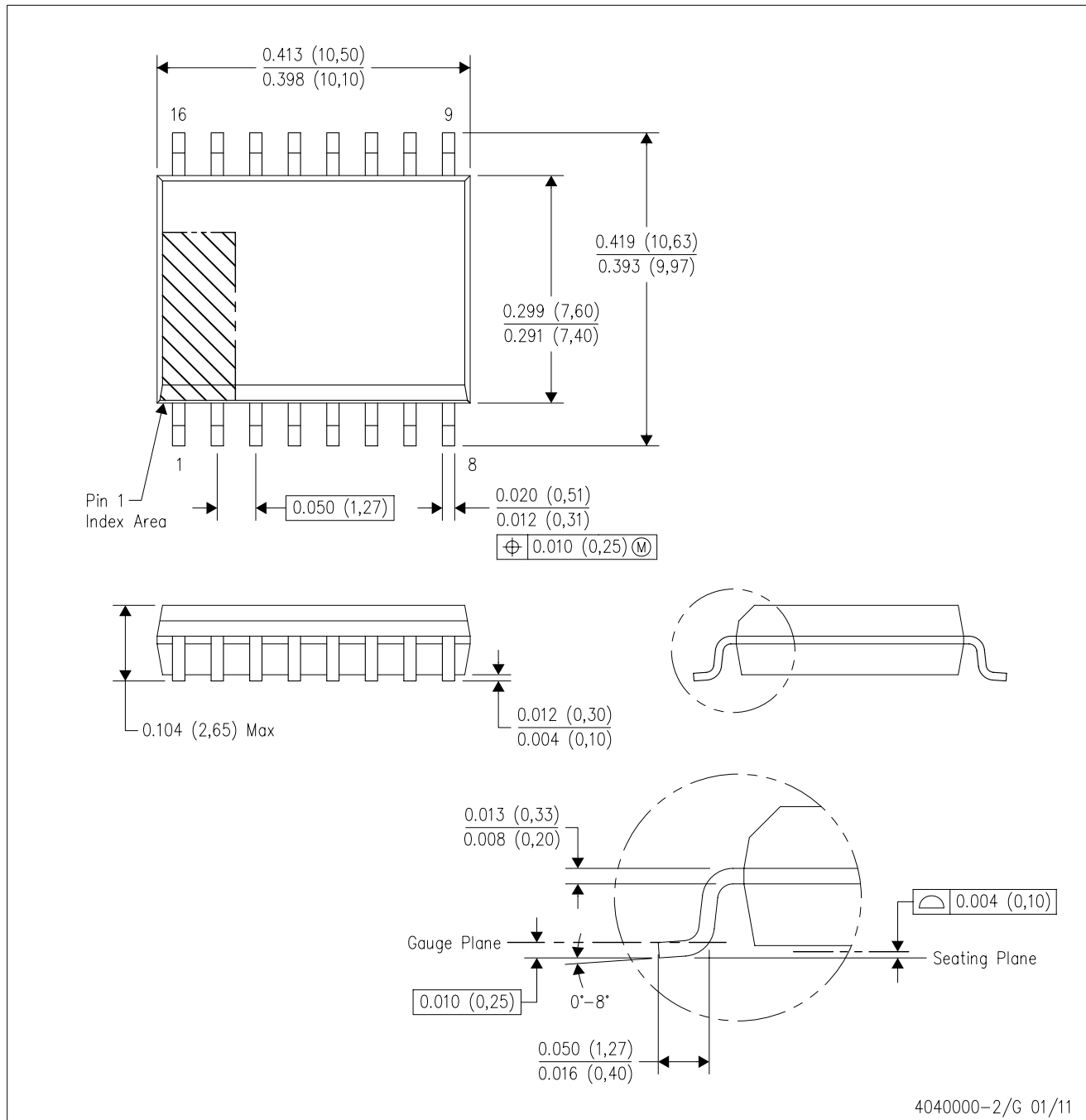

- NOTES:
- A. All linear dimensions are in inches (millimeters). Dimensioning and tolerancing per ASME Y14.5M-1994.
 - B. This drawing is subject to change without notice.
 - C. Body dimensions do not include mold flash or protrusion not to exceed 0.006 (0,15).
 - D. Falls within JEDEC MS-013 variation AA.

DW (R-PDSO-G16)

PLASTIC SMALL OUTLINE

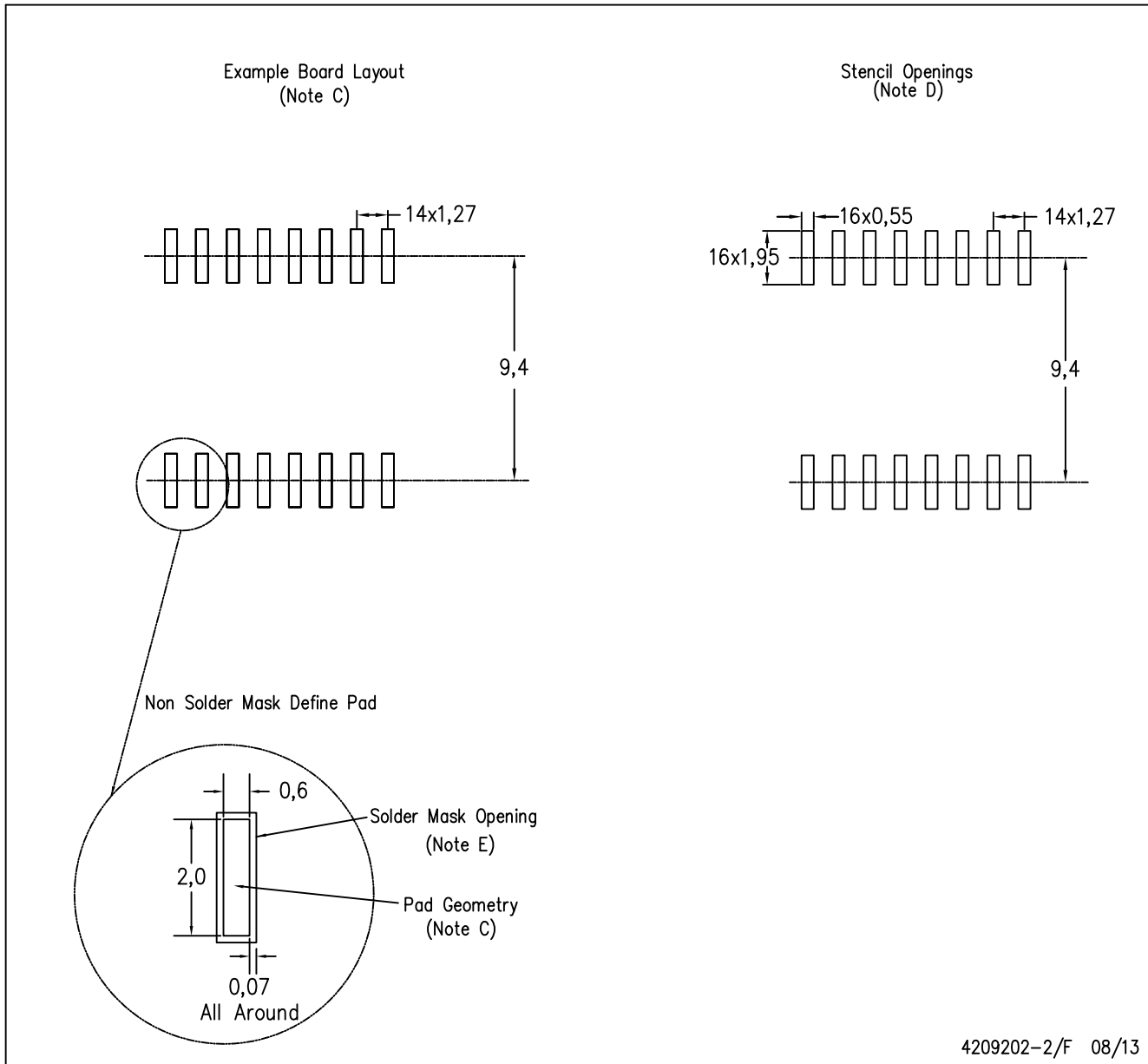

4209202-2/F 08/13

- NOTES:
- A. All linear dimensions are in millimeters.
 - B. This drawing is subject to change without notice.
 - C. Refer to IPC7351 for alternate board design.
 - D. Laser cutting apertures with trapezoidal walls and also rounding corners will offer better paste release. Customers should contact their board assembly site for stencil design recommendations. Refer to IPC-7525
 - E. Customers should contact their board fabrication site for solder mask tolerances between and around signal pads.

IMPORTANT NOTICE

Texas Instruments Incorporated and its subsidiaries (TI) reserve the right to make corrections, enhancements, improvements and other changes to its semiconductor products and services per JESD46, latest issue, and to discontinue any product or service per JESD48, latest issue. Buyers should obtain the latest relevant information before placing orders and should verify that such information is current and complete. All semiconductor products (also referred to herein as "components") are sold subject to TI's terms and conditions of sale supplied at the time of order acknowledgment.

TI warrants performance of its components to the specifications applicable at the time of sale, in accordance with the warranty in TI's terms and conditions of sale of semiconductor products. Testing and other quality control techniques are used to the extent TI deems necessary to support this warranty. Except where mandated by applicable law, testing of all parameters of each component is not necessarily performed.

TI assumes no liability for applications assistance or the design of Buyers' products. Buyers are responsible for their products and applications using TI components. To minimize the risks associated with Buyers' products and applications, Buyers should provide adequate design and operating safeguards.

TI does not warrant or represent that any license, either express or implied, is granted under any patent right, copyright, mask work right, or other intellectual property right relating to any combination, machine, or process in which TI components or services are used. Information published by TI regarding third-party products or services does not constitute a license to use such products or services or a warranty or endorsement thereof. Use of such information may require a license from a third party under the patents or other intellectual property of the third party, or a license from TI under the patents or other intellectual property of TI.

Reproduction of significant portions of TI information in TI data books or data sheets is permissible only if reproduction is without alteration and is accompanied by all associated warranties, conditions, limitations, and notices. TI is not responsible or liable for such altered documentation. Information of third parties may be subject to additional restrictions.

Resale of TI components or services with statements different from or beyond the parameters stated by TI for that component or service voids all express and any implied warranties for the associated TI component or service and is an unfair and deceptive business practice. TI is not responsible or liable for any such statements.

Buyer acknowledges and agrees that it is solely responsible for compliance with all legal, regulatory and safety-related requirements concerning its products, and any use of TI components in its applications, notwithstanding any applications-related information or support that may be provided by TI. Buyer represents and agrees that it has all the necessary expertise to create and implement safeguards which anticipate dangerous consequences of failures, monitor failures and their consequences, lessen the likelihood of failures that might cause harm and take appropriate remedial actions. Buyer will fully indemnify TI and its representatives against any damages arising out of the use of any TI components in safety-critical applications.

In some cases, TI components may be promoted specifically to facilitate safety-related applications. With such components, TI's goal is to help enable customers to design and create their own end-product solutions that meet applicable functional safety standards and requirements. Nonetheless, such components are subject to these terms.

No TI components are authorized for use in FDA Class III (or similar life-critical medical equipment) unless authorized officers of the parties have executed a special agreement specifically governing such use.

Only those TI components which TI has specifically designated as military grade or "enhanced plastic" are designed and intended for use in military/aerospace applications or environments. Buyer acknowledges and agrees that any military or aerospace use of TI components which have **not** been so designated is solely at the Buyer's risk, and that Buyer is solely responsible for compliance with all legal and regulatory requirements in connection with such use.

TI has specifically designated certain components as meeting ISO/TS16949 requirements, mainly for automotive use. In any case of use of non-designated products, TI will not be responsible for any failure to meet ISO/TS16949.

Products

Audio	www.ti.com/audio
Amplifiers	amplifier.ti.com
Data Converters	dataconverter.ti.com
DLP® Products	www.dlp.com
DSP	dsp.ti.com
Clocks and Timers	www.ti.com/clocks
Interface	interface.ti.com
Logic	logic.ti.com
Power Mgmt	power.ti.com
Microcontrollers	microcontroller.ti.com
RFID	www.ti-rfid.com
OMAP Applications Processors	www.ti.com/omap
Wireless Connectivity	www.ti.com/wirelessconnectivity

Applications

Automotive and Transportation	www.ti.com/automotive
Communications and Telecom	www.ti.com/communications
Computers and Peripherals	www.ti.com/computers
Consumer Electronics	www.ti.com/consumer-apps
Energy and Lighting	www.ti.com/energy
Industrial	www.ti.com/industrial
Medical	www.ti.com/medical
Security	www.ti.com/security
Space, Avionics and Defense	www.ti.com/space-avionics-defense
Video and Imaging	www.ti.com/video

TI E2E Community

e2e.ti.com

Looking for pricing, stock, or lifecycle information?

Click below to explore more details on WIN SOURCE:

 [View UC2544N on WIN SOURCE](#)

 [Texas Instruments](#) Information

Optimize Your Supply Chain with WIN SOURCE Solutions

-  Global Sourcing Solution
-  Obsolete Management
-  Cost Control Management
-  Shortage Management
-  Alternative Solution
-  Excess Inventory Management